

PARTS MANUAL



MODEL QP3TK TRASH PUMP (KUBOTA OC60-E4 DIESEL ENGINE)

Revision #3 (05/21/20)



THIS MANUAL MUST ACCOMPANY THE EQUIPMENT AT ALL TIMES.

PARTS FINDER

**Search Website
by Part Number**



**Search Manual
Library For Parts
Manual & Lookup Part
Numbers – Purchase
or Request Quote**

Search Manuals

Enter your information to help us find the right parts manual for your machine.

* Brand:

* Model:

* Serial:

* Part Number:

SEARCH

**Can't Find Part or
Manual? Request Help
by Manufacturer,
Model & Description**

Parts Order Form

Please fill in the following information to help us find the right part for your machine.

Manufacturer:	<input type="text"/>
Model:	<input type="text"/>
Description:	<input type="text"/>
Part Number:	<input type="text"/>
Quantity:	<input type="text"/>
Notes:	<input type="text"/>

Submit

Discount-Equipment.com is your online resource for quality parts & equipment.

Florida: **561-964-4949** Outside Florida TOLL FREE: **877-690-3101**

Need parts?

Click on this link: <http://www.discount-equipment.com/category/5443-parts/> and choose one of the options to help get the right parts and equipment you are looking for. Please have the machine model and serial number available in order to help us get you the correct parts. If you don't find the part on the website or on one of the online manuals, please fill out the request form and one of our experienced staff members will get back to you with a quote for the right part that your machine needs.

We sell worldwide for the brands: Genie, Terex, JLG, MultiQuip, Mikasa, Essick, Whiteman, Mayco, Toro Stone, Diamond Products, Generac Magnum, Airman, Haulotte, Barreto, Power Blanket, Nifty Lift, Atlas Copco, Chicago Pneumatic, Allmand, Miller Curber, Skyjack, Lull, Skytrak, Tsurumi, Husquvarna Target, Stow, Wacker, Sakai, Mi-T-M, Sullair, Basic, Dynapac, MBW, Weber, Bartell, Bennar Newman, Haulotte, Ditch Runner, Menegotti, Morrison, Contec, Buddy, Crown, Edco, Wyco, Bomag, Laymor, EZ Trench, Bil-Jax, F.S. Curtis, Gehl Pavers, Heli, Honda, ICS/PowerGrit, IHI, Partner, Imer, Clipper, MMD, Koshin, Rice, CH&E, General Equipment, Amida, Coleman, NAC, Gradall, Square Shooter, Kent, Stanley, Tamco, Toku, Hatz, Kohler, Robin, Wisconsin, Northrock, Oztec, Toker TK, Rol-Air, APT, Wylie, Ingersoll Rand / Doosan, Innovatech, Con X, Ammann, Mecalac, Makinex, Smith Surface Prep, Small Line, Wanco, Yanmar

QP3TK Trash Pump

Explanation Of Code In Remarks Column..... 4
Suggested Spare Parts 5

Component Drawings

Pump Assembly..... 6-9
Engine/Battery Mounting Assembly..... 10-11
Engine Service Parts..... 12-13

NOTICE

Specifications and part numbers are subject to change without notice.

Go to Discount-Equipment.com to order your parts

EXPLANATION OF CODE IN REMARKS COLUMN

The following section explains the different symbols and remarks used in the Parts section of this manual. Use the help numbers found on the back page of the manual if there are any questions.

NOTICE

The contents and part numbers listed in the parts section are subject to change **without notice**. Multiquip does not guarantee the availability of the parts listed.

SAMPLE PARTS LIST

NO.	PART NO.	PART NAME	QTY.	REMARKS
1	12345	BOLT	1	INCLUDES ITEMS W/%
2%		WASHER, 1/4 IN.		NOT SOLD SEPARATELY
2%	12347	WASHER, 3/8 IN. ...	1	MQ-45T ONLY
3	12348	HOSE	A/R	MAKE LOCALLY
4	12349	BEARING	1	S/N 2345B AND ABOVE

NO. Column

Unique Symbols — All items with same unique symbol (@, #, +, %, or >) in the number column belong to the same assembly or kit, which is indicated by a note in the “Remarks” column.

Duplicate Item Numbers — Duplicate numbers indicate multiple part numbers, which are in effect for the same general item, such as different size saw blade guards in use or a part that has been updated on newer versions of the same machine.

NOTICE

When ordering a part that has more than one item number listed, check the remarks column for help in determining the proper part to order.

PART NO. Column

Numbers Used — Part numbers can be indicated by a number, a blank entry, or TBD.

TBD (To Be Determined) is generally used to show a part that has not been assigned a formal part number at the time of publication.

A blank entry generally indicates that the item is not sold separately or is not sold by Multiquip. Other entries will be clarified in the “Remarks” Column.

QTY. Column

Numbers Used — Item quantity can be indicated by a number, a blank entry, or A/R.

A/R (As Required) is generally used for hoses or other parts that are sold in bulk and cut to length.

A blank entry generally indicates that the item is not sold separately. Other entries will be clarified in the “Remarks” Column.

REMARKS Column

Some of the most common notes found in the “Remarks” Column are listed below. Other additional notes needed to describe the item can also be shown.

Assembly/Kit — All items on the parts list with the same unique symbol will be included when this item is purchased.

Indicated by:

“INCLUDES ITEMS W/(unique symbol)”

Serial Number Break — Used to list an effective serial number range where a particular part is used.

Indicated by:

“S/N XXXXX AND BELOW”

“S/N XXXX AND ABOVE”

“S/N XXXX TO S/N XXX”

Specific Model Number Use — Indicates that the part is used only with the specific model number or model number variant listed. It can also be used to show a part is NOT used on a specific model or model number variant.

Indicated by:

“XXXXX ONLY”

“NOT USED ON XXXX”

“Make/Obtain Locally” — Indicates that the part can be purchased at any hardware shop or made out of available items. Examples include battery cables, shims, and certain washers and nuts.

“Not Sold Separately” — Indicates that an item cannot be purchased as a separate item and is either part of an assembly/kit that can be purchased, or is not available for sale through Multiquip.

SUGGESTED SPARE PARTS

QP3TK TRASH PUMP

1 to 3 units

Qty.	P/N	Description
2	.0803442930	MECHANICAL SEAL
2	.0811885446	MECH. SEAL SLEEVE
2	.0482200240	O-RING, SEAL SLEEVE
1	.2368040031	IMPELLER
2	.0631211159	FLOODING CAP
1	.KIT3TK	KIT, MECHANICAL SEAL

NOTICE

Part numbers on this Suggested Spare Parts list may supersede/replace the part numbers shown in the following parts lists.

OC60 KUBOTA DIESEL ENGINE

1 to 3 units

Qty.	P/N	Description
1	1142041030	CAP, FUEL TANK
1	1390141350	FUEL FILTER
1	1142043012	FUEL STRAINER
5	1491132110	OIL FILTER
3	1142011180	AIR FILTER

PUMP ASSEMBLY

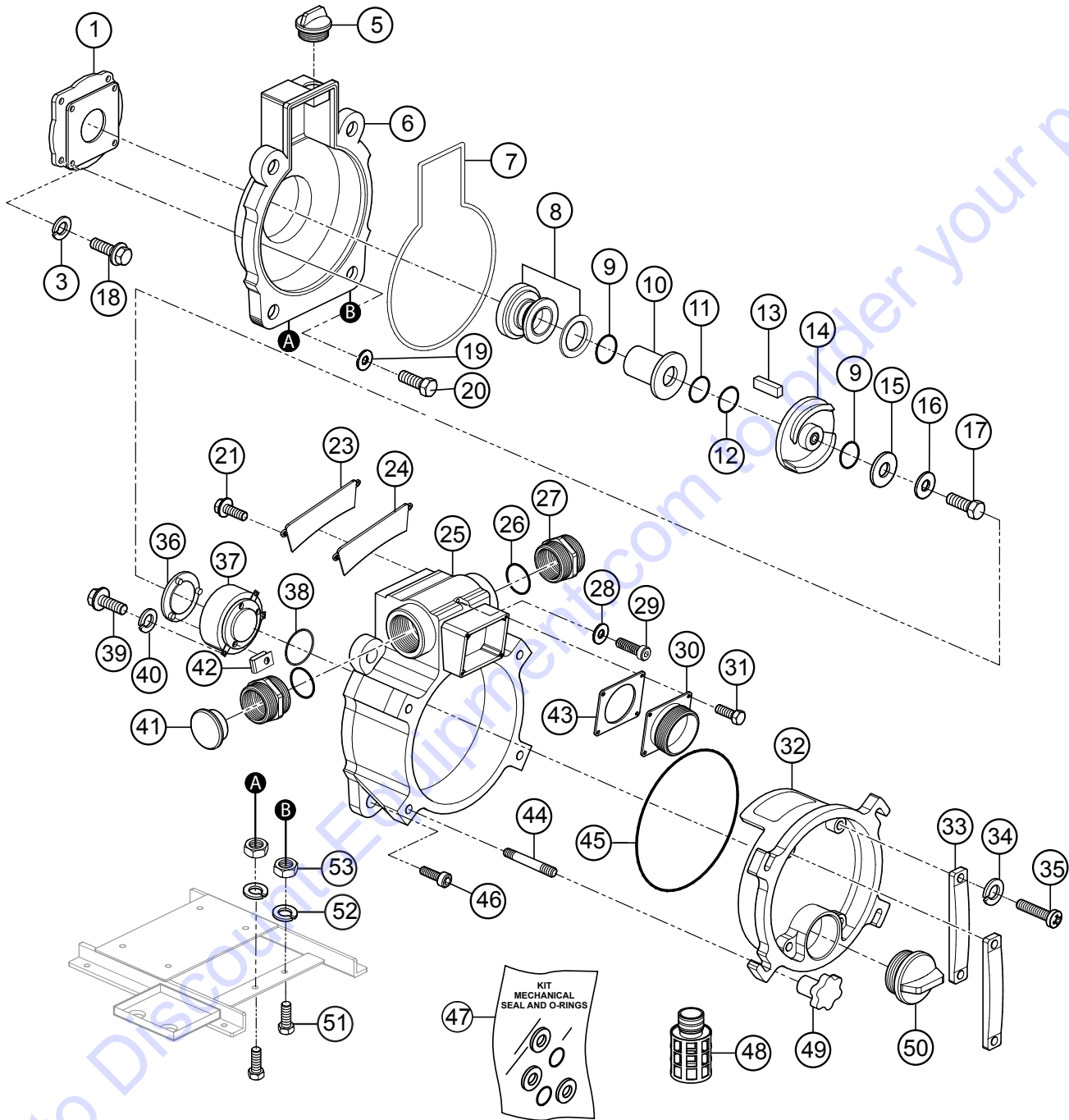

PUMP ASSEMBLY

<u>NO.</u>	<u>PART NO.</u>	<u>PART NAME</u>	<u>QTY.</u>	<u>REMARKS</u>
1	43130006000014	CASING COVER SET PLATE	1	
3	0451250100	WASHER SPRING 10MM S/STEEL.....	4	REPLACES P/N 0451290100
5	0631211159	CAP, FLOODING W/O-RING	1	
6	1992100020	CASING COVER	1	
7	0489403400	O-RING, CASING	1	
8#	0803442930	MECHANICAL SEAL	1	
9#	0482200240	O-RING, MECHANICAL SEAL SLEEVE	2	
10#	0811885446	MECHANICAL SEAL SLEEVE	1	
11#	0852834525	ADJUST LINER	1	
12#	0852854525	ADJUST LINER	1	
13	0520040431	KEY	1	
14	2368040031	IMPELLER	1	
15	1466251240	IMPELLER WASHER.....	1	REPLACES P/N 43342012400011
16	0458220100	SEAL WASHER, IMPELLER	1	
17	0191190750	BOLT, IMPELLER	1	
18	0191170625	BOLT SET W/WASHER, LOCK, SUCT. PLATE	4	
19	0458220080	SEAL WASHER, CASING COVER	4	
20	0105090820	BOLT, CASING COVER	4	
21	0181090820	BOLT SET W/WASHER, LOCK, SUCT. PLATE	2	
23	1992100742	SUCTION PLATE	1	
24	1992330410	SUCTION PLATE PACKING	1	
25	1992100011	CASING	1	
26	0481310800	O-RING, NIPPLE	2	
27	07904330300014	NIPPLE	2	
28	0459220120	SEAL WASHER, CASING	1	
29	0131191290	CAP SCREW, CASING	1	
30	13910001600014	SUCTION COVER	1	
31	0181090825	BOLT SET W/WASHER, LOCK, SUCT. CVR.	4	
32	1992100173	DRAIN COVER	1	
33	12471002500002	DRAIN COVER HANDLE.....	2	REPLACES P/N 1247100250
34	0451290080	WASHER, LOCK, DRAIN COVER SET HANDLE	4	
35	0141090825	SCREW, DRAIN COVER SET HANDLE	4	

PUMP ASSEMBLY

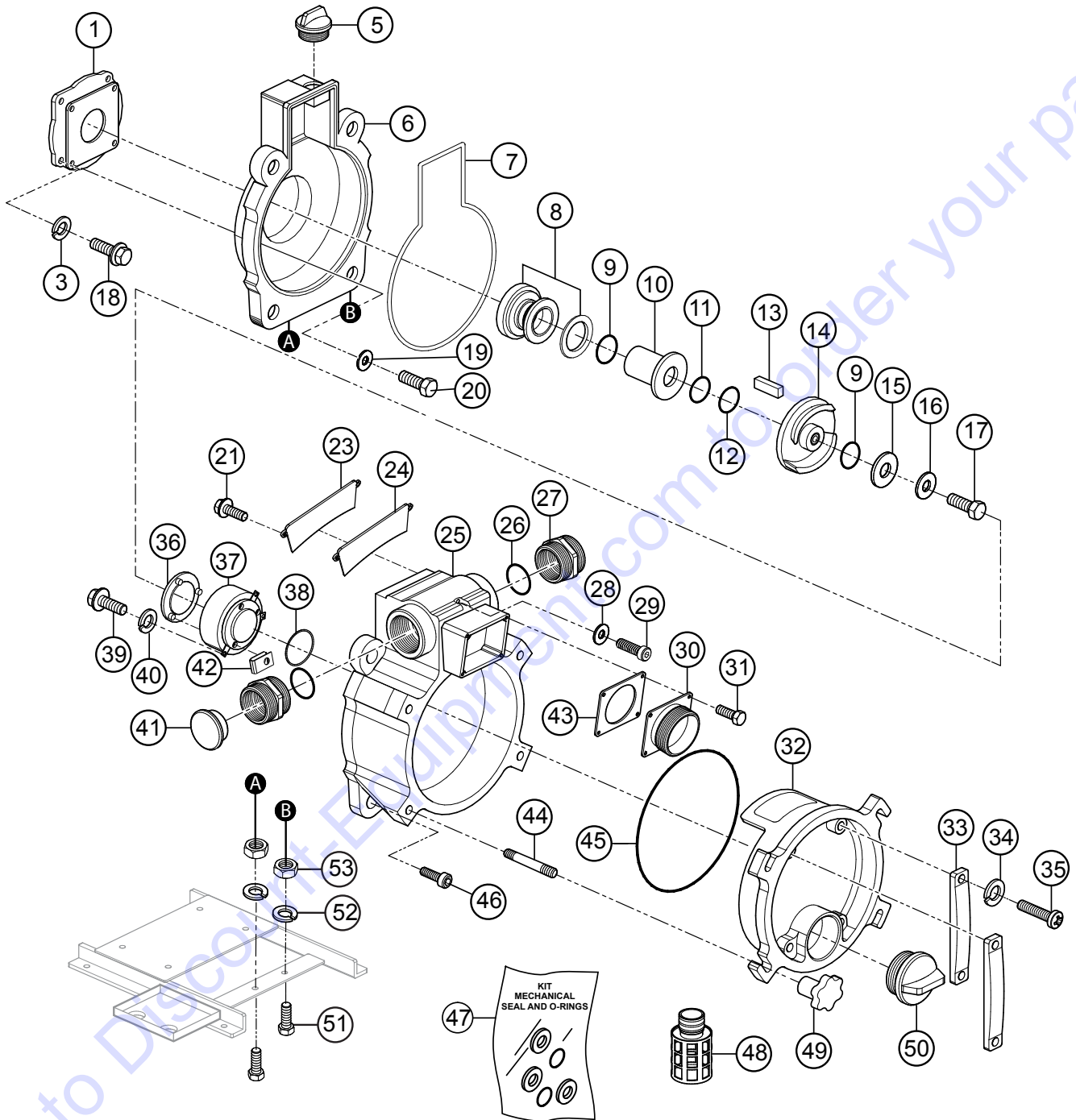

PUMP ASSEMBLY

<u>NO.</u>	<u>PART NO.</u>	<u>PART NAME</u>	<u>QTY.</u>	<u>REMARKS</u>
36	1992250700	WEAR PLATE	1	
37	2368000110	VOLUTE CASING	1	
38	0480570850	O-RING	1	
39	0131190823	CAP SCREW, VOLUTE CASING	4	
40	0451290080	WASHER, LOCK, VOLUTE CASING	4	
41	1992108050	CAP	1	
42	0204490060	U-NUT, WEAR PLATE	3	
43	1378350350	CHECK VALVE	1	
44	0151191257	STUD BOLT, DRAIN COVER HANDLE	4	
45	0483602250	O-RING, DRAIN COVER	1	
46	0131191235	CAP SCREW, CASING	4	
47	KIT3TK	KIT, MECHANICAL SEAL.....	1	INCLUDES ITEMS W/#
48	0742214080	STRAINER	1	
49	19920002200014	DRAIN COVER HANDLE	4	
50	0631211159	CAP, FLOODING W/O-RING	1	
51	0105091040	BOLT, PUM	2	
52	0451250100	WASHER SPRING 10MM S/STEEL.....	2	REPLACES P/N 0451290100
53	020310080	NUT, PUMP.....	2	REPLACES P/N 0205490100

ENGINE/BATTERY MOUNTING ASSEMBLY

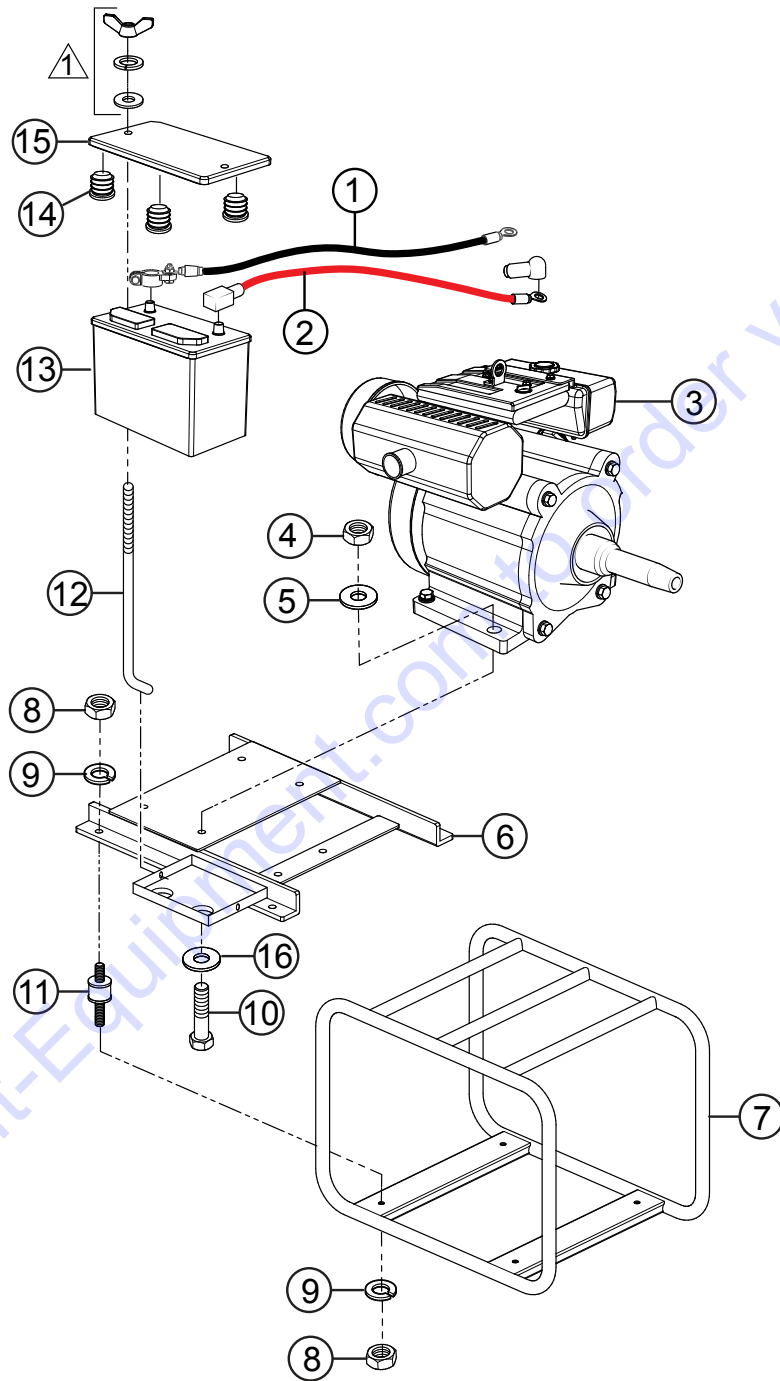

NOTE:

△ INCLUDED WITH ITEM 12.

ENGINE/BATTERY MOUNTING ASSEMBLY

<u>NO.</u>	<u>PART NO.</u>	<u>PART NAME</u>	<u>QTY.</u>	<u>REMARKS</u>
1	0975209300	NEGATIVE CABLE W/TERMINALS	1	
2	0976209450	POSITIVE CABLE W/TERMINALS	1	
3	1J1970000	ENGINE, KUBOTA OC60-E4	1	
4	020310080	NUT, ENGINE	4.....	REPLACES P/N 0205490100
5	0451250100	WASHER, LOCK, ENGINE.....	4.....	REPLACES P/N 0451290100
6	23932140200014	BASE, ENGINE	1	
7	2277214010P002	BASE, PUMP	1	
8	0205490080	NUT, CUSHION RUBBER	8	
9	0451290080	WASHER, LOCK, CUSHION RUBBER	8	
10	0105091045	BOLT, ENGINE	4	
11	0723303032	CUSHION, RUBBER	4	
12	0950241265A0002	BATTERY BOLT W/NUT	2	
13	0162212024	BATTERY, 12V (12N24-3A)	1.....	BATTERY SOLD SEPARATELY
14	1412317030	CAP	3	
15	09592250000014	BATTERY COVER	1	
16	0401650100	WASHER, ENGINE	4	

Go to Discount-Equipment.com to order your parts

ENGINE SERVICE PARTS

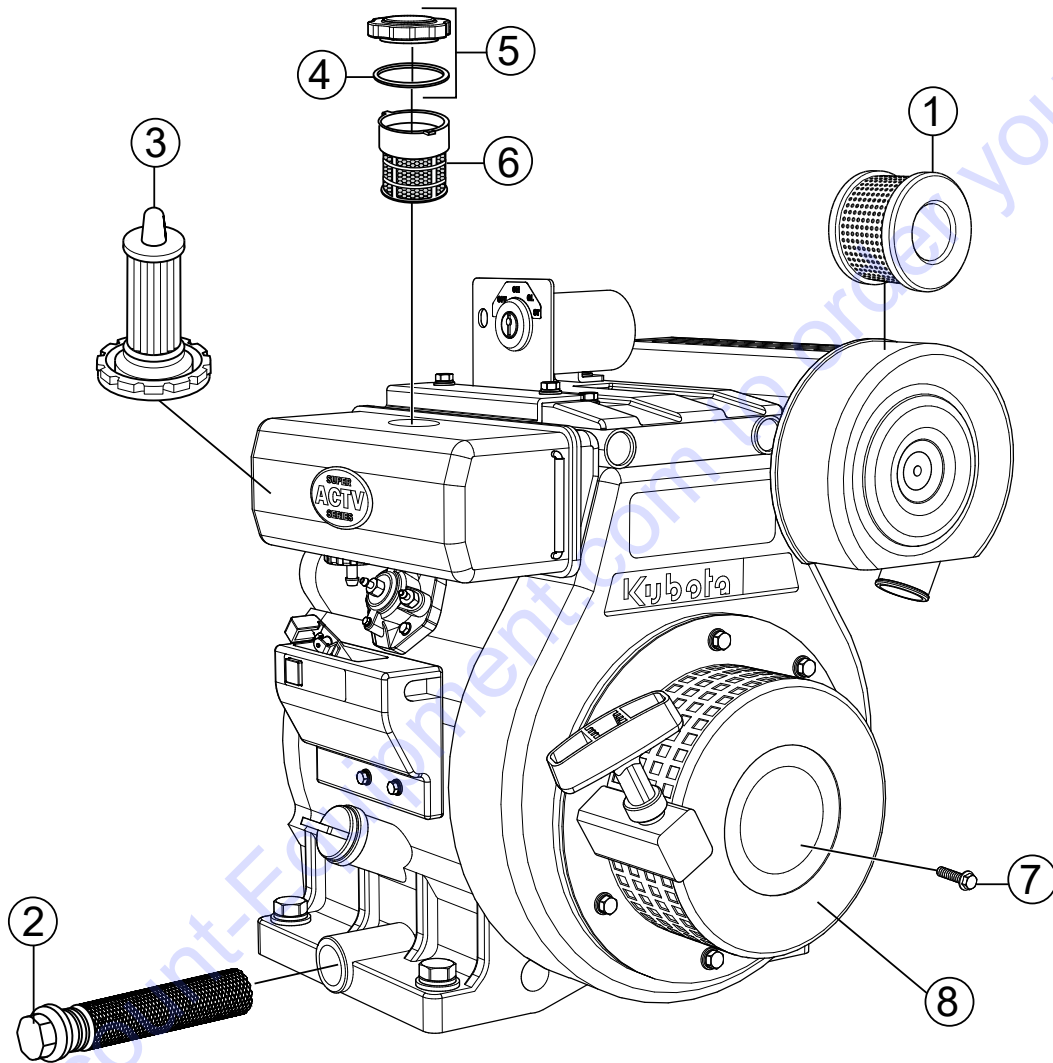

ENGINE SERVICE PARTS

<u>NO.</u>	<u>PART NO.</u>	<u>PART NAME</u>	<u>QTY.</u>	<u>REMARKS</u>
1	1142011180	AIR FILTER	1	
2	1491132110	OIL FILTER	1	
3	1142043012	FUEL FILTER	1	
4#	1390141340	GASKET	1	
5	1142041030	CAP, FUEL TANK	1.....	INCLUDES ITEM W#
6	1142043012	FUEL STRAINER	1	
7	0183150612CE	FLANGE BOLTS	1.....	3 PCS, S/N 0291 AND ABOVE
8	1155061010	RECOIL STARTER ASSEMBLY	1.....	S/N 0291 AND ABOVE

Go to Discount-Equipment.com to order your parts

PARTS FINDER

**Search Website
by Part Number**



**Search Manual
Library For Parts
Manual & Lookup Part
Numbers – Purchase
or Request Quote**

Search Manuals

Enter your information to help us find the right parts manual for your machine.

* Brand:

* Model:

* Serial:

* Part Number:

SEARCH

**Can't Find Part or
Manual? Request Help
by Manufacturer,
Model & Description**

Parts Order Form

Please fill in the following information to help us find the right part for your machine.

Manufacturer:	<input type="text"/>
Model:	<input type="text"/>
Description:	<input type="text"/>
Part Number:	<input type="text"/>
Quantity:	<input type="text"/>
Notes:	<input type="text"/>

Submit

Discount-Equipment.com is your online resource for quality parts & equipment.

Florida: **561-964-4949** Outside Florida TOLL FREE: **877-690-3101**

Need parts?

Click on this link: <http://www.discount-equipment.com/category/5443-parts/> and choose one of the options to help get the right parts and equipment you are looking for. Please have the machine model and serial number available in order to help us get you the correct parts. If you don't find the part on the website or on one of the online manuals, please fill out the request form and one of our experienced staff members will get back to you with a quote for the right part that your machine needs.

We sell worldwide for the brands: Genie, Terex, JLG, MultiQuip, Mikasa, Essick, Whiteman, Mayco, Toro Stone, Diamond Products, Generac Magnum, Airman, Haulotte, Barreto, Power Blanket, Nifty Lift, Atlas Copco, Chicago Pneumatic, Allmand, Miller Curber, Skyjack, Lull, Skytrak, Tsurumi, Husquvarna Target, Stow, Wacker, Sakai, Mi-T-M, Sullair, Basic, Dynapac, MBW, Weber, Bartell, Bennar Newman, Haulotte, Ditch Runner, Menegotti, Morrison, Contec, Buddy, Crown, Edco, Wyco, Bomag, Laymor, EZ Trench, Bil-Jax, F.S. Curtis, Gehl Pavers, Heli, Honda, ICS/PowerGrit, IHI, Partner, Imer, Clipper, MMD, Koshin, Rice, CH&E, General Equipment, Amida, Coleman, NAC, Gradall, Square Shooter, Kent, Stanley, Tamco, Toku, Hatz, Kohler, Robin, Wisconsin, Northrock, Oztec, Toker TK, Rol-Air, APT, Wylie, Ingersoll Rand / Doosan, Innovatech, Con X, Ammann, Mecalac, Makinex, Smith Surface Prep, Small Line, Wanco, Yanmar