

PARTS MANUAL



MODEL LT6K5 50 HZ LIGHT TOWER/GENERATOR (KOHLER KDW 1003 DIESEL ENGINE)

Revision #0 (07/09/15)



THIS MANUAL MUST ACCOMPANY THE EQUIPMENT AT ALL TIMES.

PARTS FINDER

**Search Website
by Part Number**



**Search Manual
Library For Parts
Manual & Lookup Part
Numbers – Purchase
or Request Quote**

Search Manuals

Enter your information to help us find the right parts manual for your machine.

* Brand:

* Model:

* Serial:

* Part Number:

SEARCH

**Can't Find Part or
Manual? Request Help
by Manufacturer,
Model & Description**

Parts Order Form

Please fill in the following information to help us find the right part for your machine.

Manufacturer:	<input type="text"/>
Model:	<input type="text"/>
Description:	<input type="text"/>
Part Number:	<input type="text"/>
Quantity:	<input type="text"/>
Notes:	<input type="text"/>

Submit

Discount-Equipment.com is your online resource for quality parts & equipment.

Florida: **561-964-4949** Outside Florida TOLL FREE: **877-690-3101**

Need parts?

Click on this link: <http://www.discount-equipment.com/category/5443-parts/> and choose one of the options to help get the right parts and equipment you are looking for. Please have the machine model and serial number available in order to help us get you the correct parts. If you don't find the part on the website or on one of the online manuals, please fill out the request form and one of our experienced staff members will get back to you with a quote for the right part that your machine needs.

We sell worldwide for the brands: Genie, Terex, JLG, MultiQuip, Mikasa, Essick, Whiteman, Mayco, Toro Stone, Diamond Products, Generac Magnum, Airman, Haulotte, Barreto, Power Blanket, Nifty Lift, Atlas Copco, Chicago Pneumatic, Allmand, Miller Curber, Skyjack, Lull, Skytrak, Tsurumi, Husquvarna Target, Stow, Wacker, Sakai, Mi-T-M, Sullair, Basic, Dynapac, MBW, Weber, Bartell, Bennar Newman, Haulotte, Ditch Runner, Menegotti, Morrison, Contec, Buddy, Crown, Edco, Wyco, Bomag, Laymor, EZ Trench, Bil-Jax, F.S. Curtis, Gehl Pavers, Heli, Honda, ICS/PowerGrit, IHI, Partner, Imer, Clipper, MMD, Koshin, Rice, CH&E, General Equipment, Amida, Coleman, NAC, Gradall, Square Shooter, Kent, Stanley, Tamco, Toku, Hatz, Kohler, Robin, Wisconsin, Northrock, Oztec, Toker TK, Rol-Air, APT, Wylie, Ingersoll Rand / Doosan, Innovatech, Con X, Ammann, Mecalac, Makinex, Smith Surface Prep, Small Line, Wanco, Yanmar

TABLE OF CONTENTS

LT6K5 50 Hz Light Tower

Table Of Contents.....	2
Parts Ordering Procedures.....	3
Explanation Of Code In Remarks Column.....	4
Suggested Spare Parts	5

Component Drawings

Nameplate And Decals.....	6-13
Cabinet Assembly.....	14-15
Rear Panel Assembly.....	16-17
Front Panel Assembly.....	18-19
Ballast And Capacitor Assembly.....	20-21
Tower Assembly.....	22-23
Mast Base Assembly.....	24-25
Mast Assembly.....	26-27
Winch Assembly.....	28-29
T-Bar Assembly.....	30-31
Engine Mounting.....	32-33
Engine And Components.....	34-35
Tub/Trailer Assembly.....	36-37
Tongue Assembly.....	38-39
Jack Assy.....	40-41
Generator Assy.....	42-43
Battery Assy.....	44-45
Coil cord Assy.....	46-47
Lamp Assy.....	48-49
Control panel Assy.....	50-51
Fuel Tank, Hoses And Mounting Assy.....	52-53
Harness Assembly.....	54-55
Terms And Conditions Of Sale — Parts	56
Notes	57

NOTICE

Specifications and part numbers are subject to change without notice.

EXPLANATION OF CODE IN REMARKS COLUMN

The following section explains the different symbols and remarks used in the Parts section of this manual. Use the help numbers found on the back page of the manual if there are any questions.

NOTICE

The contents and part numbers listed in the parts section are subject to change **without notice**. Multiquip does not guarantee the availability of the parts listed.

SAMPLE PARTS LIST

NO.	PART NO.	PART NAME	QTY.	REMARKS
1	12345	BOLT	1	INCLUDES ITEMS W/%
2%		WASHER, 1/4 IN.		NOT SOLD SEPARATELY
2%	12347	WASHER, 3/8 IN. ...	1	MQ-45T ONLY
3	12348	HOSE	A/R	MAKE LOCALLY
4	12349	BEARING	1	S/N 2345B AND ABOVE

NO. Column

Unique Symbols — All items with same unique symbol (@, #, +, %, or >) in the number column belong to the same assembly or kit, which is indicated by a note in the “Remarks” column.

Duplicate Item Numbers — Duplicate numbers indicate multiple part numbers, which are in effect for the same general item, such as different size saw blade guards in use or a part that has been updated on newer versions of the same machine.

NOTICE

When ordering a part that has more than one item number listed, check the remarks column for help in determining the proper part to order.

PART NO. Column

Numbers Used — Part numbers can be indicated by a number, a blank entry, or TBD.

TBD (To Be Determined) is generally used to show a part that has not been assigned a formal part number at the time of publication.

A blank entry generally indicates that the item is not sold separately or is not sold by Multiquip. Other entries will be clarified in the “Remarks” Column.

QTY. Column

Numbers Used — Item quantity can be indicated by a number, a blank entry, or A/R.

A/R (As Required) is generally used for hoses or other parts that are sold in bulk and cut to length.

A blank entry generally indicates that the item is not sold separately. Other entries will be clarified in the “Remarks” Column.

REMARKS Column

Some of the most common notes found in the “Remarks” Column are listed below. Other additional notes needed to describe the item can also be shown.

Assembly/Kit — All items on the parts list with the same unique symbol will be included when this item is purchased.

Indicated by:

“INCLUDES ITEMS W/(unique symbol)”

Serial Number Break — Used to list an effective serial number range where a particular part is used.

Indicated by:

“S/N XXXXX AND BELOW”

“S/N XXXX AND ABOVE”

“S/N XXXX TO S/N XXX”

Specific Model Number Use — Indicates that the part is used only with the specific model number or model number variant listed. It can also be used to show a part is NOT used on a specific model or model number variant.

Indicated by:

“XXXXX ONLY”

“NOT USED ON XXXX”

“Make/Obtain Locally” — Indicates that the part can be purchased at any hardware shop or made out of available items. Examples include battery cables, shims, and certain washers and nuts.

“Not Sold Separately” — Indicates that an item cannot be purchased as a separate item and is either part of an assembly/kit that can be purchased, or is not available for sale through Multiquip.

SUGGESTED SPARE PARTS

LT6K5 50HZ LIGHT TOWER

1 to 3 units

Qty.	P/N	Description
2	MVR1000BT37	BULB, LIGHT FIXTURE
1	190ZQREF	REF 1000 LENS
1	200ZG106	GASKET, U-CHANL REFLEC
1	12009	FILTER, IN-TANK (FUEL)
1	29694	CAP, FUEL W/LANYARD
1	59018	EXCITATIONCAPACITOR50HZ
1	005-1475-MF	CAPACITOR, 30mF @ 440V
1	29798	BALLAST/TRANSFORMER ASSY
2	34098	CIRCUIT BREAKER, 15A
1	34846	BREAKER, GFCI, 50HZ
1	34096	CIRCUIT BREAKER, 30A
1	34093	JACK, 2000#, 10" TOP WIND
1	34101	COVER, ACCESS PANEL
1	34378	GASKET, ACCESS PANEL
1	16185	FITTING, PLUG
1	59010	HANDLE, WINCH

KOHLER KDW1003 DIESEL ENGINE

1 to 3 units

Qty.	P/N	Description
3	ED0021752880S	FUEL FILTER
3	ED0021752830S	OIL FILTER
3	ED0021751640S	CARTRIDGE, AIR FILTER
1	ED0024403200S	FAN BELT
1	ED0067450560S	OIL PRESSURE SWITCH
2	ED34001S	KEY, IGNITION, DBL SIDED

NOTICE

Part numbers on this Suggested Spare Parts list may supersede/replace the part numbers shown in the following parts lists.

NAMEPLATE AND DECALS

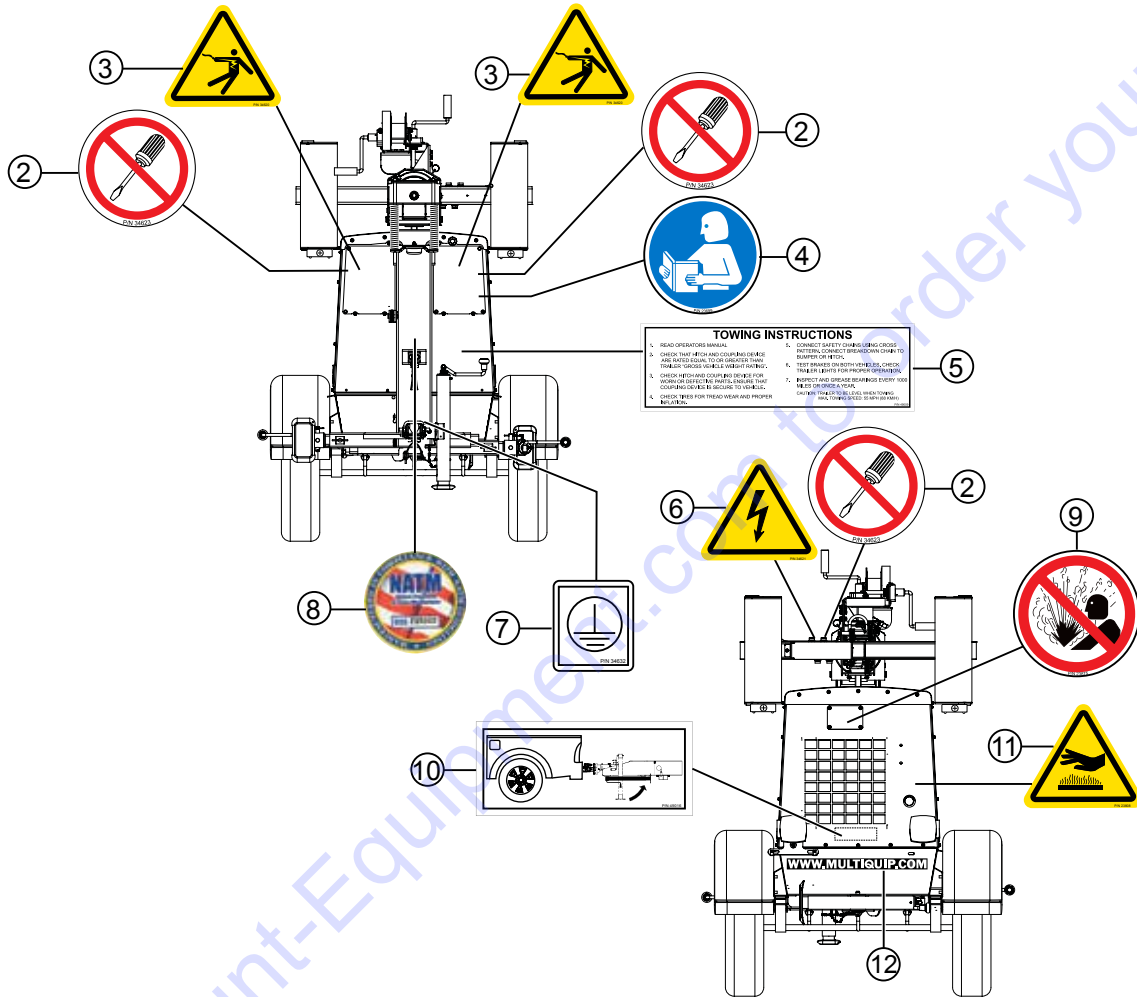

NAMEPLATE AND DECALS

<u>NO.</u>	<u>PART NO.</u>	<u>PART NAME</u>	<u>QTY.</u>	<u>REMARKS</u>
2	34623	DECAL ISO: DO NOT DISASSEMBLE HAZARD, 2.00" DIA.	3	
3	34620	DECAL ISO: ELECTROCUTION HAZARD, 2.4" X 2.0"	2	
4	23699	DECAL ISO: READ MANUAL, 2.00" DIA.	1	
5	49009	DECAL: TOWING INSTRUCTIONS, 7.75" X 2.5	1	
6	34621	DECAL ISO: HIGH VOLTAGE HAZARD, 2.4" X 2.0"	1	
7	34632	DECAL ISO: GROUND 1.00" X 1.00"	1	
8	EE56342	DECAL: NATM, 2.75" DIA.	1	
9	23875	DECAL ISO: HOT COOLANT HAZARD, 2.00" DIA.	1	
10	49016	DECAL: HORIZONTAL JACK STANDS 4.10" X 1.80"	3	
11	23808	DECAL ISO: HOT SURFACE HAZARD 2.4" X 2.00"	2	
12	34808	DECAL: MQ WEBSITE 18.00" X 1.20"	1	

Go to Discount-Equipment.com to order your parts

NAMEPLATE AND DECALS

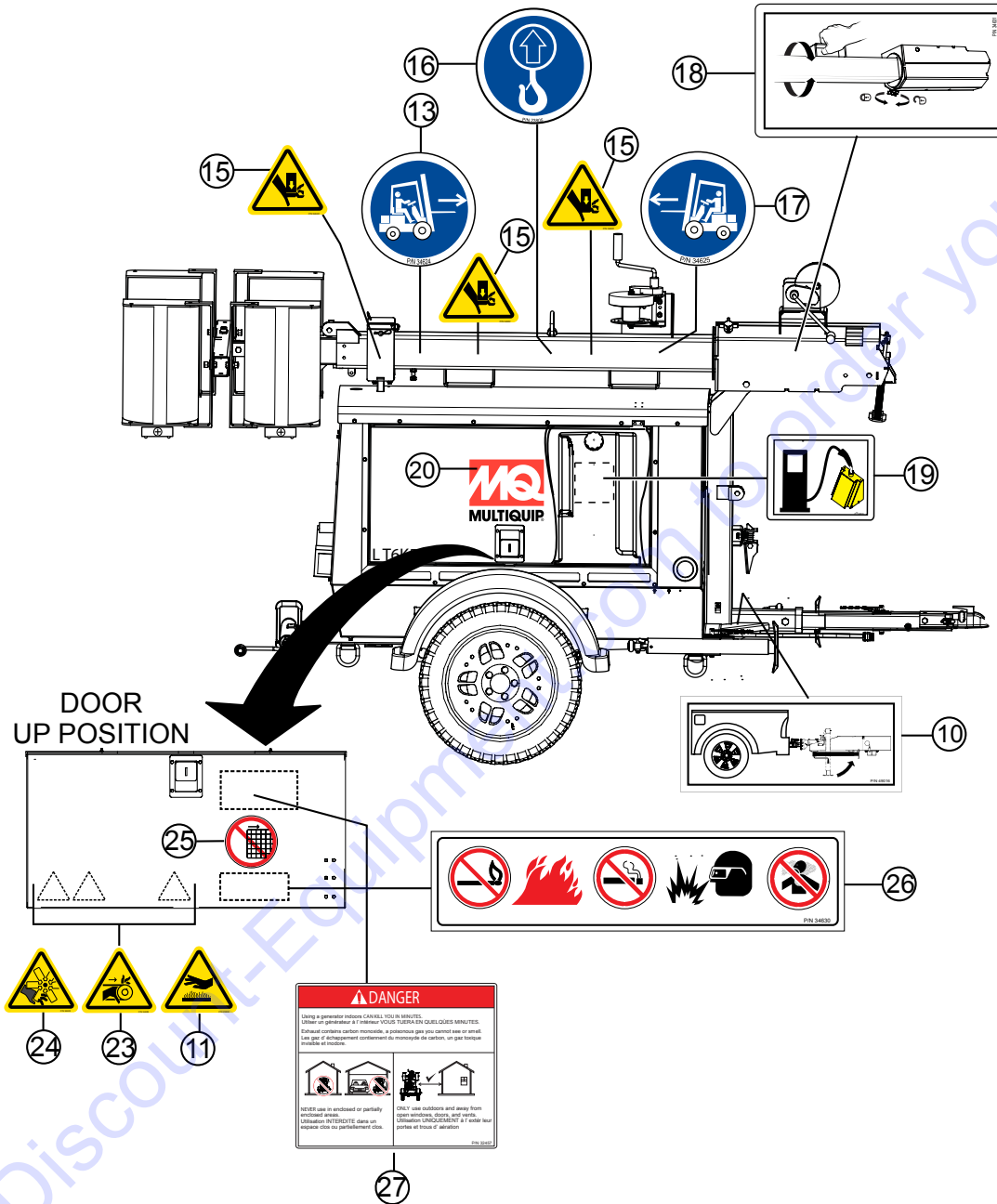

NAMEPLATE AND DECALS

<u>NO.</u>	<u>PART NO.</u>	<u>PART NAME</u>	<u>QTY.</u>	<u>REMARKS</u>
10	49016	DECAL: HORIZONTAL JACK STANDS 4.10" X 1.80"	3	
11	23808	DECAL ISO: HOT SURFACE HAZARD 2.4" X 2.00"	2	
13	34624	DECAL ISO: FORK LIFT LEFT 2.00" DIA.	2	
15	34622	DECAL ISO: CRUSH HAZARD 2.4" X 2.0"	6	
16	34626	DECAL ISO: LIFTING POINT 2.00" DIA	2	
17	34625	DECAL ISO: FORK LIFT RIGHT 2.00" DIA	2	
18	34631	DECAL: MAST ROTATION, 2.00" X 2.45"	1	
19	23813	DECAL: FUEL, DIESEL 2.00" X 2.45"	1	
20	34806	DECAL: MQ LOGO 12.00" X 10.00"	2	
23	34629	DECAL ISO: ENTANGLEMENT HAZARD, 2.4" X 2.00"	2	
24	34628	DECAL ISO: BLADE ROTATION HAZARD, 2.4" X 2.00"	2	
25	23874	DECAL ISO: DO NOT REMOVE GUARDS HAZARD 2.00" DIA.	2	
26	34630	DECAL: FIRE, EXPLOSION, SMOKING HAZ. 6.50" X 1.40"	1	
27	32457	DECAL ISO, SMOKE INHALATION, 2.00" DIA.	1	

NAMEPLATE AND DECALS

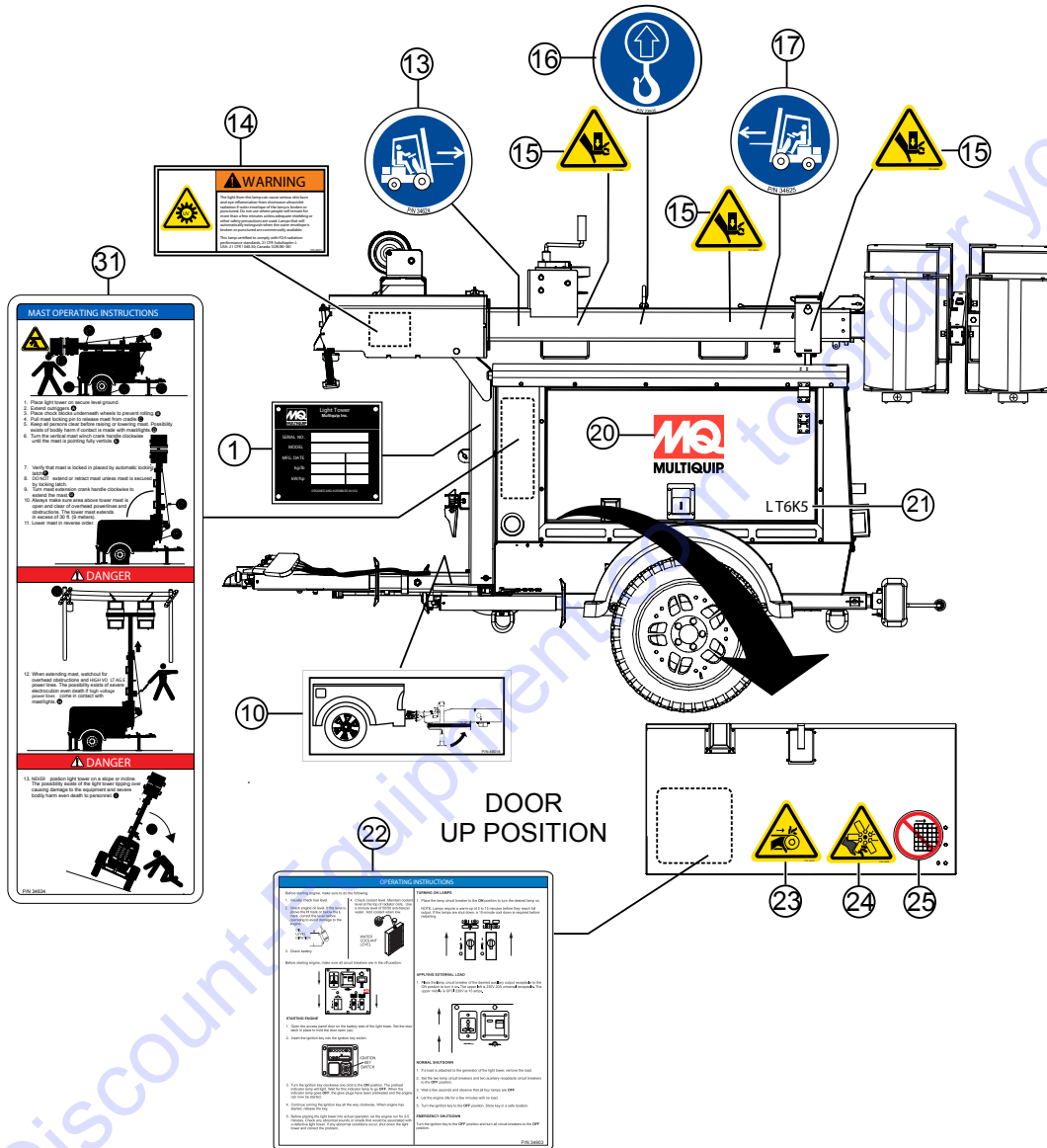

NAMEPLATE AND DECALS

<u>NO.</u>	<u>PART NO.</u>	<u>PART NAME</u>	<u>QTY.</u>	<u>REMARKS</u>
1		DECAL: SERIAL PLATE	1	
10	49016	DECAL: HORIZONTAL JACK STANDS 4.10" X 1.80"	3	
13	34624	DECAL ISO: FORK LIFT LEFT 2.00" DIA.	2	
14	49911	DECAL: WARNING UV RADIATION, 6.50" X 3.40"	1	
15	34622	DECAL ISO: CRUSH HAZARD 2.4" X 2.0"	6	
16	34626	DECAL ISO: LIFTING POINT 2.00" DIA	2	
17	34625	DECAL ISO: FORK LIFT RIGHT 2.00" DIA	2	
20	34806	DECAL: MQ LOGO 12.00" X 10.00"	2	
21	34902	DECAL: LT6K5 LOGO 8.00" X 3.00"	2	
22	34903	DECAL: OPERATING INSTRUCTIONS 13.25" X 13.25"	1	
23	34629	DECAL ISO: ENTANGLEMENT HAZARD, 2.4" X 2.00"	2	
24	34628	DECAL ISO: BLADE ROTATION HAZARD, 2.4" X 2.00"	2	
25	23874	DECAL ISO: DO NOT REMOVE GUARDS HAZARD 2.00" DIA.	2	
31	34634	DECAL: MAST OPERATING INSTR., 16.23" X 5.2"	1	

Go to Discount-Equipment.com to order your parts

NAMEPLATE AND DECALS

⚠ WARNING	⚠ WARNING	⚠ WARNING	⚠ WARNING
<p>To prevent uncoupling from the tow vehicle perform the following:</p> <ol style="list-style-type: none"> CHECK BALL and COUPLER for worn or defective parts. CHECK that BALL is load rated is the same as or greater than the COUPLER load rating. CHECK that the BALL and COUPLER are the same size. Open COUPLER CLAMP and place onto BALL. Close COUPLER CLAMP. LB COUPLER upwards to test that it will not separate from BALL. LOCK coupler clamp with pin or lock. 	<p>ALWAYS use safety chains. Safety chains keep unit attached to tow vehicle in the event of coupler malfunction.</p> <p>Perform the following when attaching safety chains:</p> <p>TOW VEHICLE FRAME</p> <ol style="list-style-type: none"> CROSS 6 chains underneath coupler. ALLOW for slack for trailer to turn. ATTACH safety chain hooks securely to tow vehicle frame. 	<p>Lights can prevent trailer from being hit by other vehicles. Perform the following when connecting the trailer lights:</p> <p>DISCONNECTED</p> <p>CONNECTED</p> <ol style="list-style-type: none"> CONNECT trailer and tow vehicle light plugs. CHECK all lights: ball, turn, signal and brake. Make sure all lights are working properly. DO NOT TO W if lights are not working correctly. 	<p>Tire, wheel or lug nut failure can cause loss of control. Perform the following before towing:</p> <ol style="list-style-type: none"> CHECK tire pressure and tread. CHECK tire and wheels for damage. CHECK lug nuts for tightness. For new and resurfaced wheels re-tighten lug nuts at first 10, 25 and 50 miles of driving. CHECK tire and test brakes on both vehicles. INSPECT T and grease trailer bearings every 3000 miles or once a year. Trailer to be level when towing. Maximum towing speed not to exceed 55 MPH (88 KM/H).

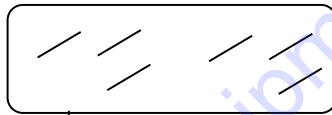
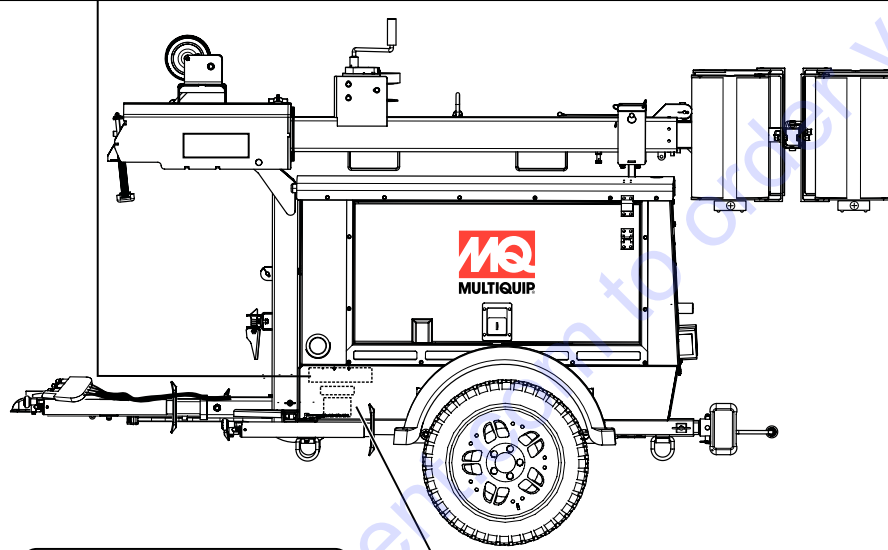

28

MANUFACTURED BY: FARMER PARK MULTIQUIP INC.		DATE:
OWNER: FARMER PARK	COLOUR: PRESS / PRESS	DE COVER: 10/2010
PAINT COLOUR: ASBESTO	TIRE: (P/ST)	REF: (P/ST) (1/1)

THIS TRAILER IS COMPLIANT WITH ALL APPLICABLE REGULATIONS PROVIDED THAT THE OPERATOR USES IT AS A SAFETY TRAILER IN ACCORDANCE WITH THE RULES OF THE ROAD. THE USER SHALL BE RESPONSIBLE FOR THE TRAILER'S SAFETY AND PERFORMANCE. THE USER SHALL BE RESPONSIBLE FOR THE TRAILER'S SAFETY AND PERFORMANCE.

THE USER SHALL BE RESPONSIBLE FOR THE TRAILER'S SAFETY AND PERFORMANCE.

CAUTION: TIRE: TRAILER

29

THE USER SHALL BE RESPONSIBLE FOR THE TRAILER'S SAFETY AND PERFORMANCE.		DATE:
OWNER: FARMER PARK	COLOUR: PRESS / PRESS	DE COVER: 10/2010
PAINT COLOUR: ASBESTO	TIRE: (P/ST)	REF: (P/ST) (1/1)

30

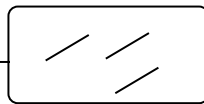

NAMEPLATE AND DECALS

<u>NO.</u>	<u>PART NO.</u>	<u>PART NAME</u>	<u>QTY.</u>	<u>REMARKS</u>
27	34627	DECAL: WARNING, TOWING 13.1" X 2.3"	1	
28	EE56313	OVERLAY	1	
29		DECAL: VIN AND TIRE TAG.....	1	
			
30	EE56314	OVERLAY	1	

Go to Discount-Equipment.com to order your parts

CABINET ASSY.

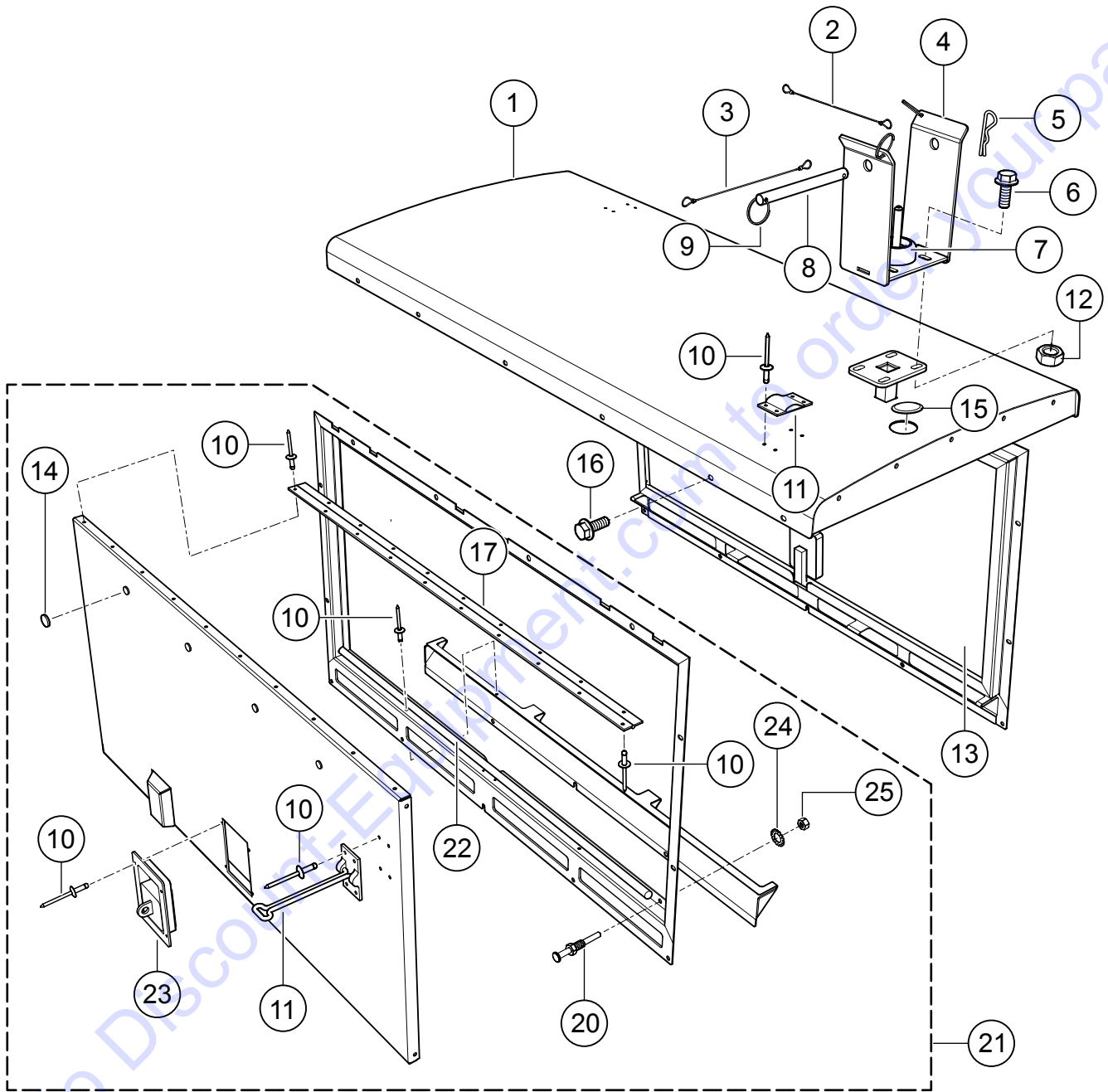

CABINET ASSY.

<u>NO.</u>	<u>PART NO.</u>	<u>PART NAME</u>	<u>QTY.</u>	<u>REMARKS</u>
1	34642	LID, CABINET	1	
2	19483	LANYARD 6"	1	
3	19484	LANYARD 10"	1	
4	34149	MAST SUPPORT	1	
5	34103	PIN, HAIRPIN COTTER, ZN. 2-9/16" L	1	
6	9091	SCREW, HHFS 5/16-18 X 1" GRD5	4	
7	17336	BUMPER, 2.5" DIA X 1"	1	
8	34105	PIN, ZINC PLTD., 1018 STEEL	1	
9	34102	RING, SPLIT, ZN PLTD., 1.06" ID	3	
10\$#	19847	RIVET, POP, ALUM. 3/16" X 1/8-1/4" GRIP	AR	
11\$#	34721	HOOK AND LATCH ASSY., 6"	2	
12	49071	NUT, FLANGED 5/16-18 SERRATED PLTD	4	
13	34651	DOOR ASSY, RIGHT	1	INCLUDES ITEMS W/#
14\$#	29711	BUMPER, 1/2" DIA. BLACK	8	
15	20121	PLUG, SNAP IN	1	
16	30119	SCREW, HHFS 1/4-20 X 7/8" IND HEX, DOG PT	AR	
17\$#	34658	HINGE, DOOR	2	
20\$	39171	SWITCH, MOMENTARY DOOR	1	
21	34761	DOOR, ASSY., LEFT	1	INCLUDES ITEMS W/\$
22\$#	29093	GASKET, 4' PER SIDE	8	1PC=1FT
23\$#	49137	LATCH, DOOR	2	
24\$	13339	WASHER, EXT. SHKP, 5/16"	1	
25\$	0161 D	NUT, HEX FINISH 5/16-18	1	

REAR PANEL ASSY.

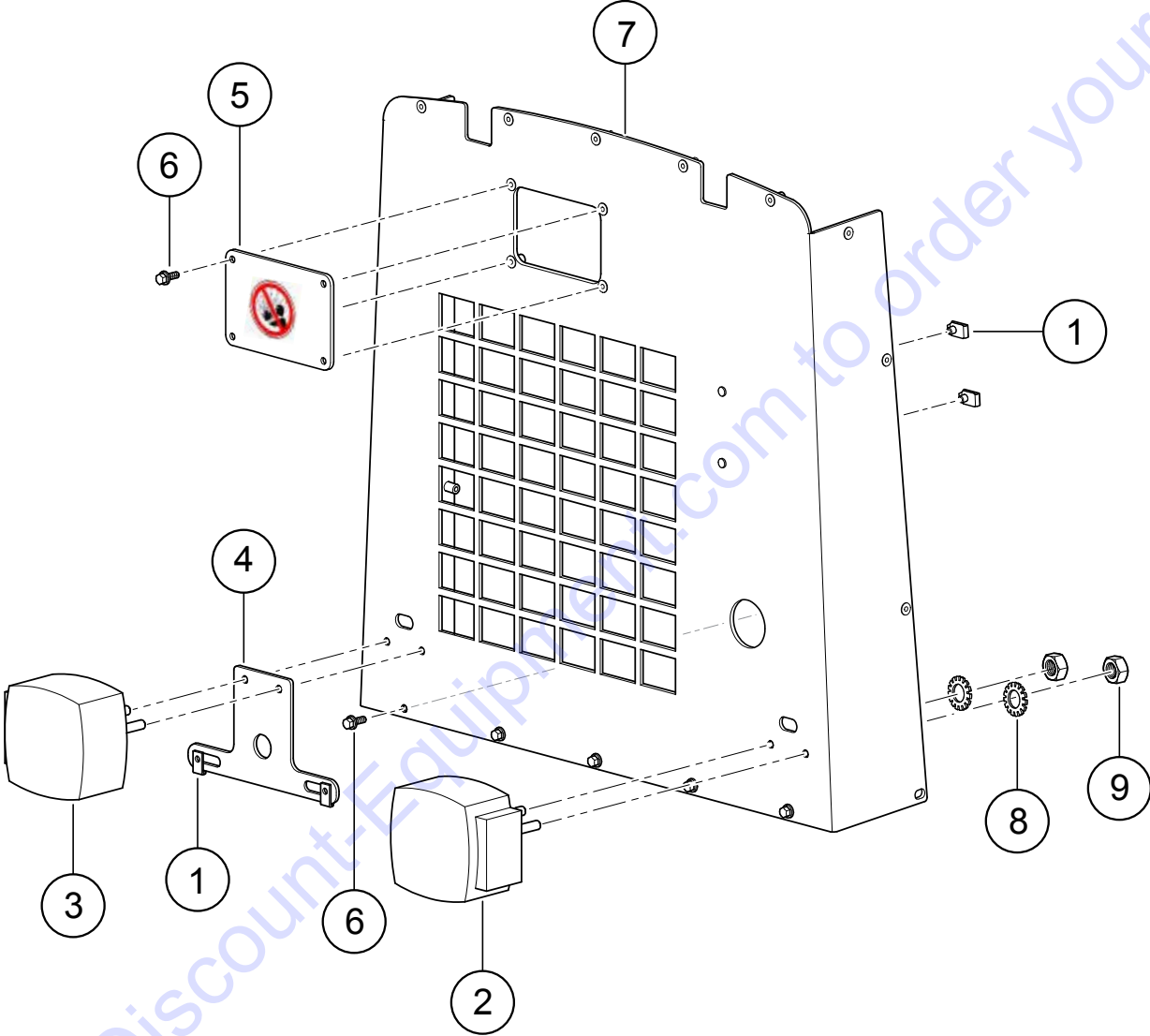

REAR PANEL ASSY.

<u>NO.</u>	<u>PART NO.</u>	<u>PART NAME</u>	<u>QTY.</u>	<u>REMARKS</u>
1	11534	NUT, "U" TYPE, 1/4-20	4	
2	29242	LIGHT, TAIL (CURB SIDE).....	1	INCLUDES ITEM W/\$
3	29243	LIGHT, TAIL (ROAD SIDE).....	1	INCLUDES ITEM W/\$
4	34682	BRACKET, LICENSE PLATE	1	
5	34877	COVER, RAD FILL ACCESS, W/GASKET & DECAL	1	
6	30119	SCREW, HHFS 1/4-20 X 7/8", IND HEX DOG PT	9	
7	34732	REAR PANEL ASM, W/ INSERTS	1	
8	10031	WASHER, EXT. SHKP, 1/4"	4	
9\$	49070	NUT, FLANGED 1/4-20 SERRATED PLTD	4	

Go to Discount-Equipment.com to order your parts

FRONT PANEL ASSY.

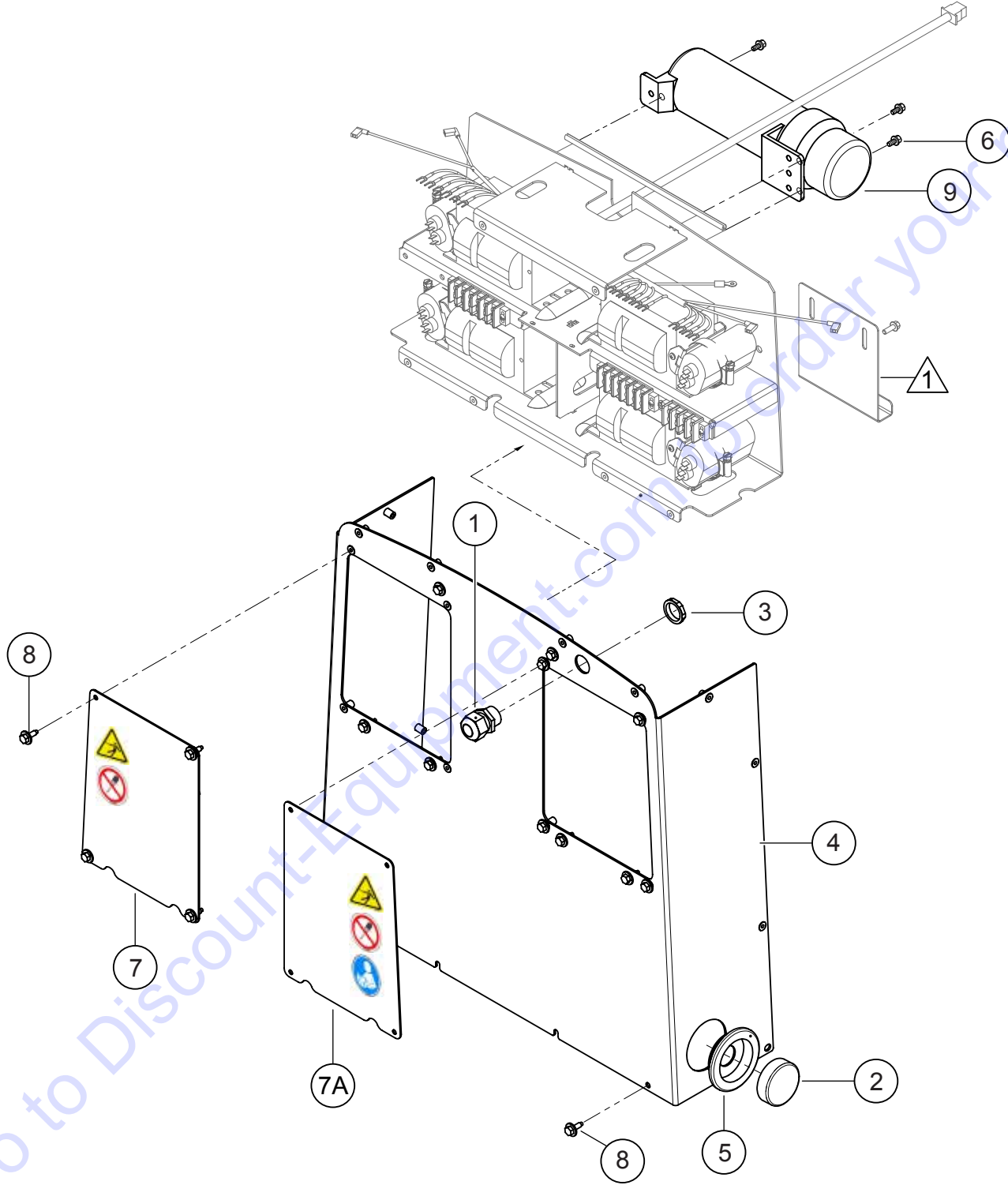

NOTE:

1 SEE FUEL TANK, HOSES, AND MOUNTING ASSY.

FRONT PANEL ASSY.

<u>NO.</u>	<u>PART NO.</u>	<u>PART NAME</u>	<u>QTY.</u>	<u>REMARKS</u>
1	29655	CORDGRIP, LIQUID TIGHT, 3/4 NPT	1	
2	29898	LIGHT, 2-1/2" SIDE MARKER, AMBER	2	
3	26560	NUT, LOCKING 3/4 NPT CONDUIT	1	
4	34763	FRONT PANEL ASSY. W/INSERTS	1	
5	29900	GROMMET W/WIRE KIT, 2-1/2", 14218K	2	
6	49048	SCREW, HHFS 1/4-20 X 3/4" GRD 5	3	
7	34879	PANEL, BALLAST ACCESS W/GASKET & DECAL	1	
7A	34878	PANEL, BALLAST ACCESS W/GASKET & DECAL	1	
8	30119	SCREW, 1/4-20 X 7/8", IND HEX DOG PT	18	
9	23297	MANUAL HOLDER, PICTOGRAPH	1	

Go to Discount-Equipment.com to order your parts

BALLAST AND CAPACITOR ASSY.

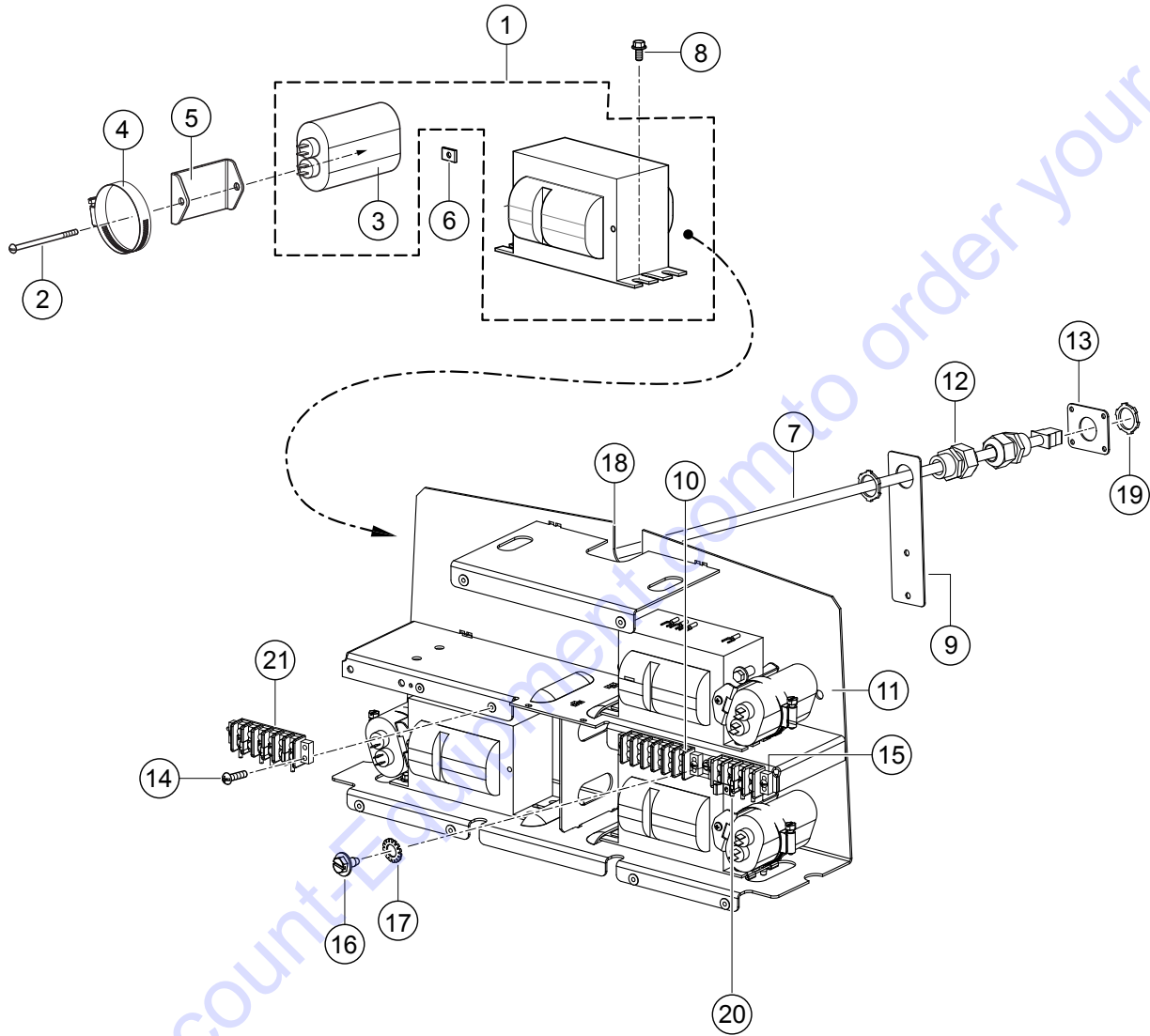

BALLAST AND CAPACITOR ASSY.

<u>NO.</u>	<u>PART NO.</u>	<u>PART NAME</u>	<u>QTY.</u>	<u>REMARKS</u>
1	29798	BALLAST/TRANSFORMER ASSY., 50Hz.....	4.....	INCLUDES ITEM W/\$
2	34821	SCREW, PHP 10-24 X 4"	4	
3\$	005-1475-MF	CAPACITOR, 30mF @ 440V	4	
4	12277	CLAMP, HOSE WORM #36	4	
5	34779	BRACKET, CAPACITOR, 50HZ	4	
6	34819	NUT, "U" TYPE, #10-24	4	
7	34835	HARNESS, LT6 BALLAST	1	
8	49048	SCREW, HHFS 1/4-20 X 3/4", GRD5	8	
9	34926	PLATE, BALLAST HARNESS COVER	1	
10	34804	TERMINAL STRIP, 6 GANG DBL ROW	2	
11	34734	BALLAST MOUNT WELDMENT	1	
12	29655	CORDGRIP, LIQUID TIGHT, 3/4 NPT	2	
13	34927	PLATE, CONTROL BOX CORD GRIP MOUNT	1	
14	8133	SCREW, PHP 10-32 X 3/4"	6	
15	34913	TERMINAL BLOCK, 4 GANG W/ JUMPER	1	
16	34305	SCREW, HHF SLOT, #10-32 X 3/8" GREEN ZN	1	
17	10237	WASHER, EXT. SHKP, #10	1	
18	28861-301	RUBBER TRIM, .33"L.....	1.....	1PC=1FT
19	26560	NUT, LOCKING 3/4 NPT CONDUIT	2	
20	19957	TERMINAL, FLANGED SPADE, 16-14 GA X #10, INSUL	AR	
21	34915	TERMINAL BLOCK W/JUMPERS, 6 GANG, BALLAST	1	

TOWER ASSY.

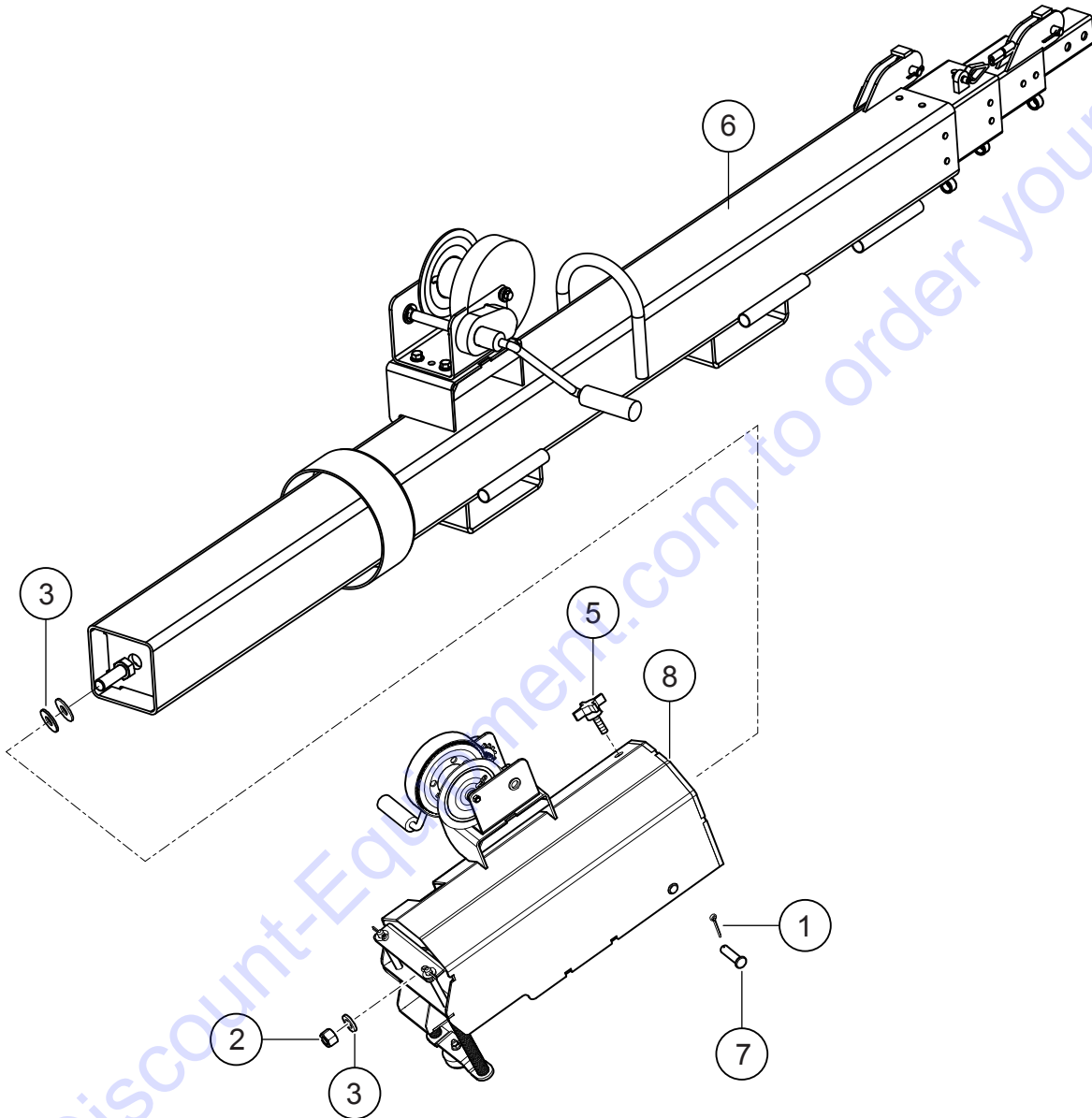

TOWER ASSY.

<u>NO.</u>	<u>PART NO.</u>	<u>PART NAME</u>	<u>QTY.</u>	<u>REMARKS</u>
1	0183	PIN, COTTER 1/8"D X 1-1/4"	2	
2	5070 B	NUT, NYLOC 3/4-10	1	
3	5079	WASHER, FLAT 3/4" USS	3	
5	19977	KNOB, CLAMP 1/2-13 THREAD	1	
6	34242	MAST ASSEMBLY	1	
7	34376	PIN,CLEVIS 5/8" X 1-3/4" EFF (2" OAL) ZP	2	
8	34751	MAST BASE ASSY.	1	

Go to Discount-Equipment.com to order your parts

MAST BASE ASSY.

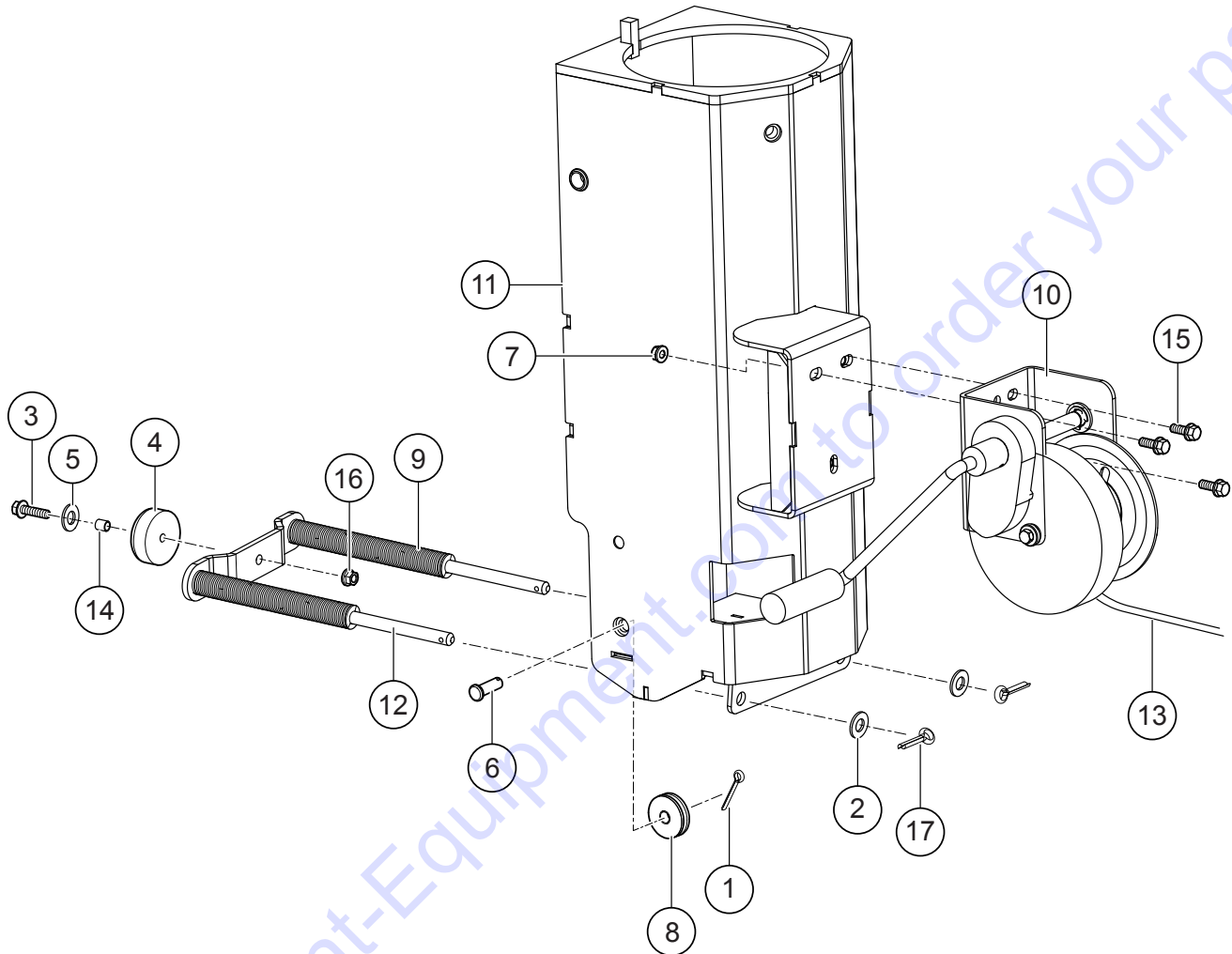

MAST BASE ASSY.

<u>NO.</u>	<u>PART NO.</u>	<u>PART NAME</u>	<u>QTY.</u>	<u>REMARKS</u>
1	0183	PIN, COTTER 1/8" D X 1-1/4"	1	
2	0447	WASHER, FLAT 1/2 SAE	2	
3	2623	SCREW, HHC 5/16-18 X 1-1/4"	1	
4	17336	BUMPER, 2.5" DIA X 1"	1	
5	19470	WASHER, FLAT 5/16 USS	1	
6	19974	PIN, CLEVIS 1/2" X 1.25" EFF	1	
7	21781	NUT, FLANGED 3/8-16 SERRATED PLTD	3	
8	29155	SHEAVE, 2.0" OD X 0.50" ID	1	
9	34362	SPRING, CENTURY D-1145	2	
10	34636	WINCH, BRAKE, 1500LBS (680KG)	1	
11	34742	SWIVEL BASE	1	
12	34752	SPRING MOUNT, MAST RETURN	1	
13	34794	CABLE, MAST, 3/16" X 112"	1	
14	34810	SPACER, .32" ID X .41" OD X .44" L	1	
15	38274	SCREW, HHFS 3/8-16 X .75" ZINC	3	
16	49071	NUT, FLANGED 5/16-18 SERRATED PLTD	1	
17	965103	PIN, COTTER 5/32" X 1", PLTD	2	

MAST ASSY.

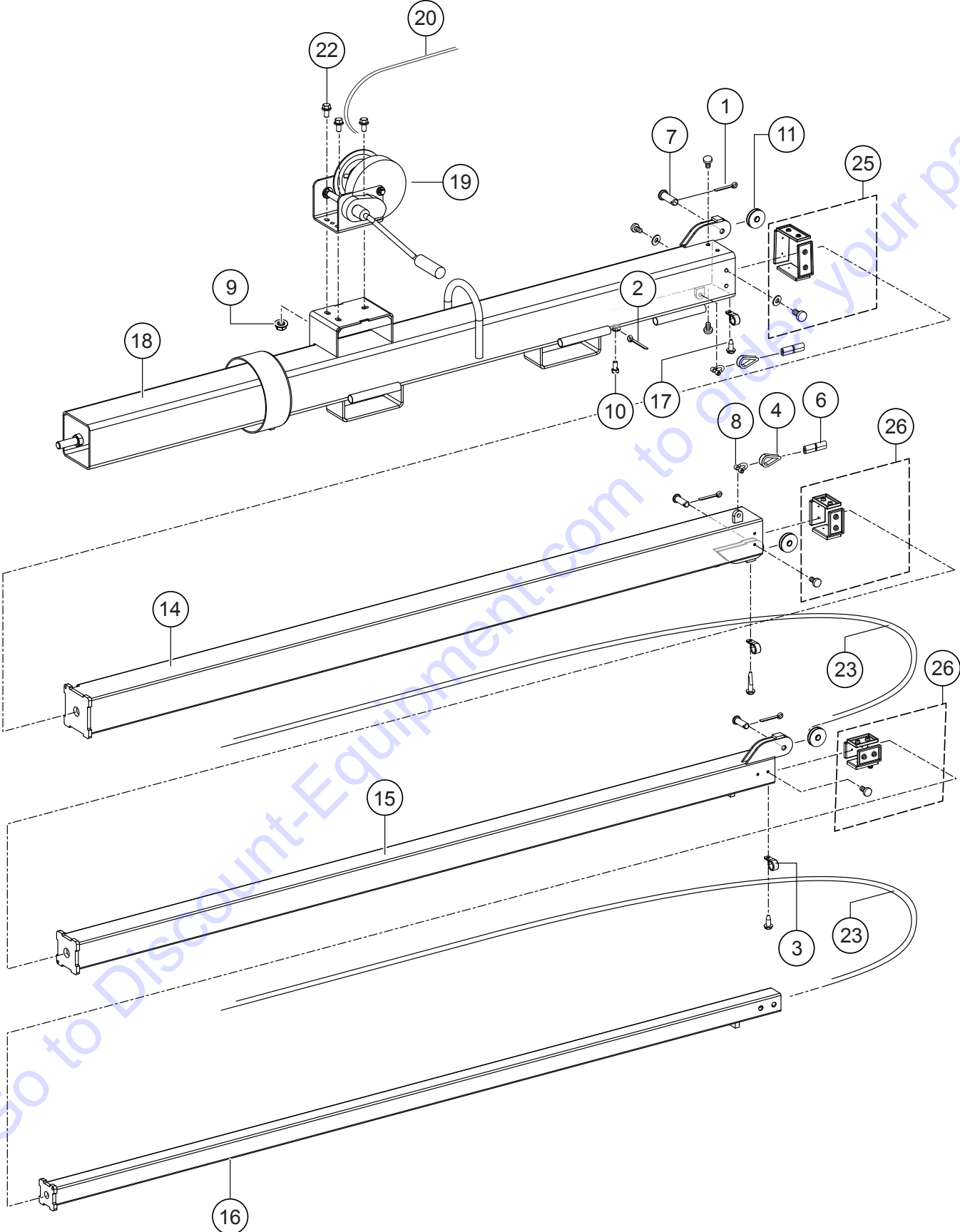

MAST ASSY.

<u>NO.</u>	<u>PART NO.</u>	<u>PART NAME</u>	<u>QTY.</u>	<u>REMARKS</u>
1	0183	PIN, COTTER 1/8"D X 1-1/4"	3	
2	6014 B	PIN, COTTER 3/32"D X 1	1	
3	8125	CLAMP, 5/8 LOOP X .406 HOLE	3	
4	19200	THIMBLE, 3/16 WIRE	3	
6	19973	SWAGE, AL 3/16	6	
7	19974	PIN, CLEVIS 1/2 X 1.25 EFF	3	
8	19975	SHACKLE, ANCHOR CP	2	
9	21781	NUT, FLANGED 3/8-16 SERRATED PLTD	3	
10	29075	SCREW, HHC 1/2-13 x DRILLED	1	
11	29155	SHEAVE, 2.00 OD X 0.500 ID	3	
14	34127	TUBE, BOTTOM SECTION	1	
15	34129	TUBE, MID SECTION	1	
16	34131	TUBE, TWR TOP	1	
17	34310	SCREW, HHF 1/4-20 X 3/8", TYPE F, ZP	3	
18	34237	MAST, BASE UNIT	1	
19	34636	WINCH, BRAKE, 1500 LBS (680KG)	1	
20	34796	CABLE ASSY. LOWER MAST, SERVICE W/CLIPS	1	
22	38274	SCREW, HHFS 3/8-16 X .75 ZINC	3	
23	34881	CABLE ASSY. KIT, MID MAST, SERVICE W/CLIPS	2	
25	34908	KIT, LOWER BLOCK	1	
26	34909	KIT, UPPER BLOCK	2	

WINCH ASSY.

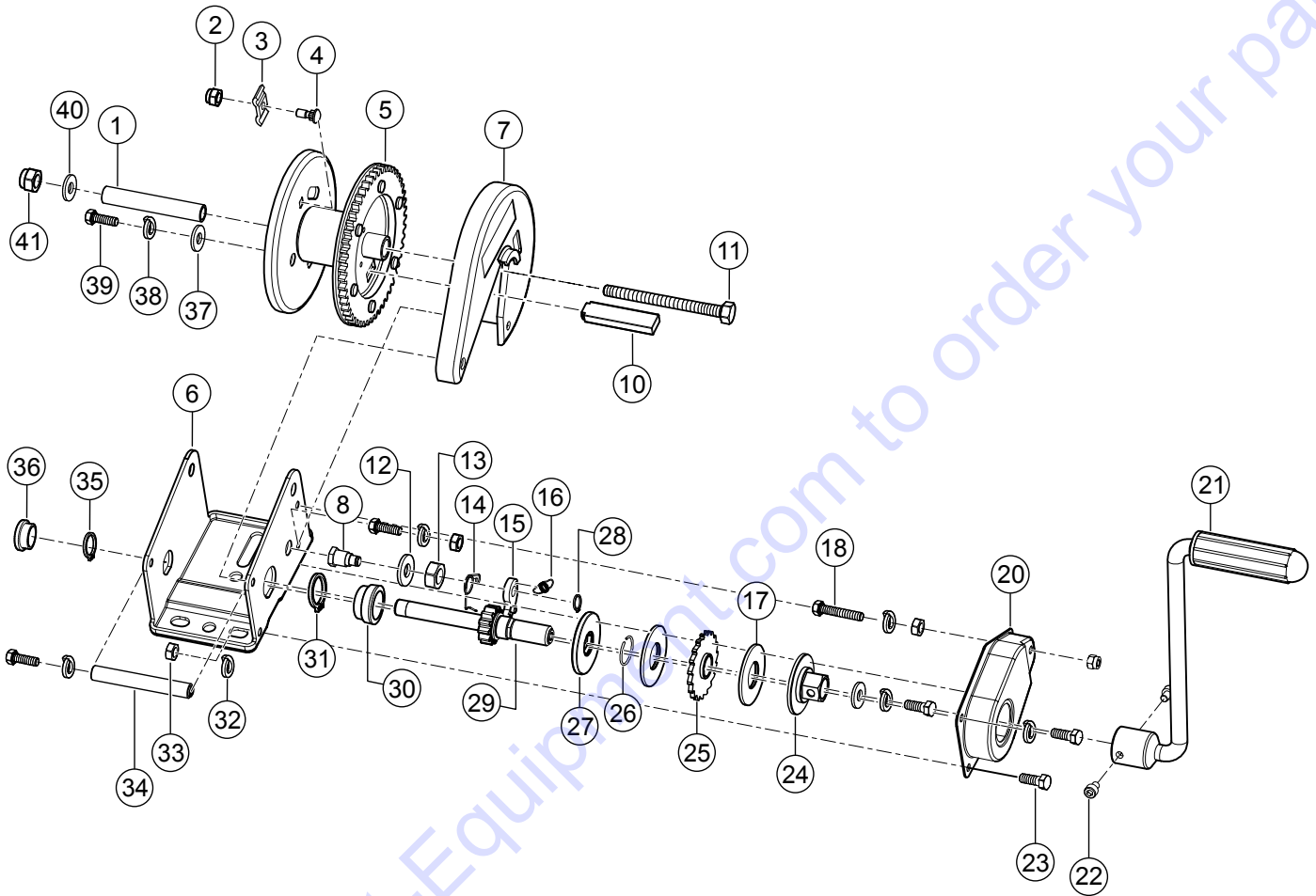

PARTS FINDER

**Search Website
by Part Number**



**Search Manual
Library For Parts
Manual & Lookup Part
Numbers – Purchase
or Request Quote**

Search Manuals

Enter your information to search for a manual or to purchase a manual or parts.

* Brand:

* Model:

* Serial:

* Part Number:

SEARCH

**Can't Find Part or
Manual? Request Help
by Manufacturer,
Model & Description**

Parts Order Form

Please fill in the following information:

Manufacturer:

Model:

Description:

Quantity:

Part Number:

Part Name:

Part Description:

Part Category:

Part Location:

Part Status:

Part Condition:

Part Material:

Part Color:

Part Weight:

Part Dimensions:

Part Price:

Part Notes:

Submit

Discount-Equipment.com is your online resource for quality parts & equipment.

Florida: **561-964-4949** Outside Florida TOLL FREE: **877-690-3101**

Need parts?

Click on this link: <http://www.discount-equipment.com/category/5443-parts/> and choose one of the options to help get the right parts and equipment you are looking for. Please have the machine model and serial number available in order to help us get you the correct parts. If you don't find the part on the website or on one of the online manuals, please fill out the request form and one of our experienced staff members will get back to you with a quote for the right part that your machine needs.

We sell worldwide for the brands: Genie, Terex, JLG, MultiQuip, Mikasa, Essick, Whiteman, Mayco, Toro Stone, Diamond Products, Generac Magnum, Airman, Haulotte, Barreto, Power Blanket, Nifty Lift, Atlas Copco, Chicago Pneumatic, Allmand, Miller Curber, Skyjack, Lull, Skytrak, Tsurumi, Husquvarna Target, Stow, Wacker, Sakai, Mi-T-M, Sullair, Basic, Dynapac, MBW, Weber, Bartell, Bennar Newman, Haulotte, Ditch Runner, Menegotti, Morrison, Contec, Buddy, Crown, Edco, Wyco, Bomag, Laymor, EZ Trench, Bil-Jax, F.S. Curtis, Gehl Pavers, Heli, Honda, ICS/PowerGrit, IHI, Partner, Imer, Clipper, MMD, Koshin, Rice, CH&E, General Equipment, Amida, Coleman, NAC, Gradall, Square Shooter, Kent, Stanley, Tamco, Toku, Hatz, Kohler, Robin, Wisconsin, Northrock, Oztec, Toker TK, Rol-Air, APT, Wylie, Ingersoll Rand / Doosan, Innovatech, Con X, Ammann, Mecalac, Makinex, Smith Surface Prep, Small Line, Wanco, Yanmar

WINCH ASSY.

<u>NO.</u>	<u>PART NO.</u>	<u>PART NAME</u>	<u>QTY.</u>	<u>REMARKS</u>
1	345110-01	RETAINING SLEEVE	1	
2	345110-02	LOCK NUT M6	1	
3	345110-03	CABLE ANCHOR	1	
4	345110-04	BOLT M6 X 15	1	
5	345110-05	DRUM WELDMENT	1	
6	345110-06	BASE	1	
7	345110-07	GEAR COVER, PLASTIC	1	
8	345110-08	BOLT M6 X 25	1	
9	345110-09	PINION-JAW	1	
10	345110-10	BELT PIN	1	OPTIONAL
11	345110-11	BOLT M10 X 108	1	
12	345110-12	WAVE SPRING WASHER 12	1	
13	345110-13	NUT M12 X 1.5	1	
14	345110-14	TORSION SPRING - JAW	1	
15	345110-15	JAW	1	
16	345110-16	EXTENSION SPRING	1	
17	345110-17	BRAKE DISC	2	
18	345110-18	BOLT M6 X 30	1	
19	345110-19	WASHER 6	1	
20	345110-20	COVER-RATCHET WHEEL	1	
21	59010	HANDLE. WINCH	1	
22	345110-22	BOLT M6 X 8	2	
23	345110-23	BOLT M6 X 12	4	
24	345110-24	BRAKE NUT	1	
25	345110-25	RATCHET ASSEMBLY	1	
26	345110-26	RETAINING RING	1	
27	345110-27	RETAINING DISC	1	
28	345110-28	CIRCLIP 8	1	
29	345110-29	BRAKE GEAR PINION	1	
30	345110-30	BUSH-BIG 20	1	
31	345110-31	CIRCLIP 26	1	
32	345110-32	SPRING WASHER 6	6	
33	345110-33	NUT M6	3	
34	345110-34	RETAINING PINION	1	
35	345110-35	SPRING RETAINER	1	
36	345110-36	BUSH-SMALL 12.8	1	
37	345110-37	WASHER(OPTIONAL)	1	
38	345110-38	SPRING WASHER(OPTIONAL)	1	
39	345110-39	BOLT M6 X 12(OPTIONAL)	1	
40	345110-40	WASHER 10	1	
41	345110-41	LOCK NUT M10	1	

T-BAR ASSY.

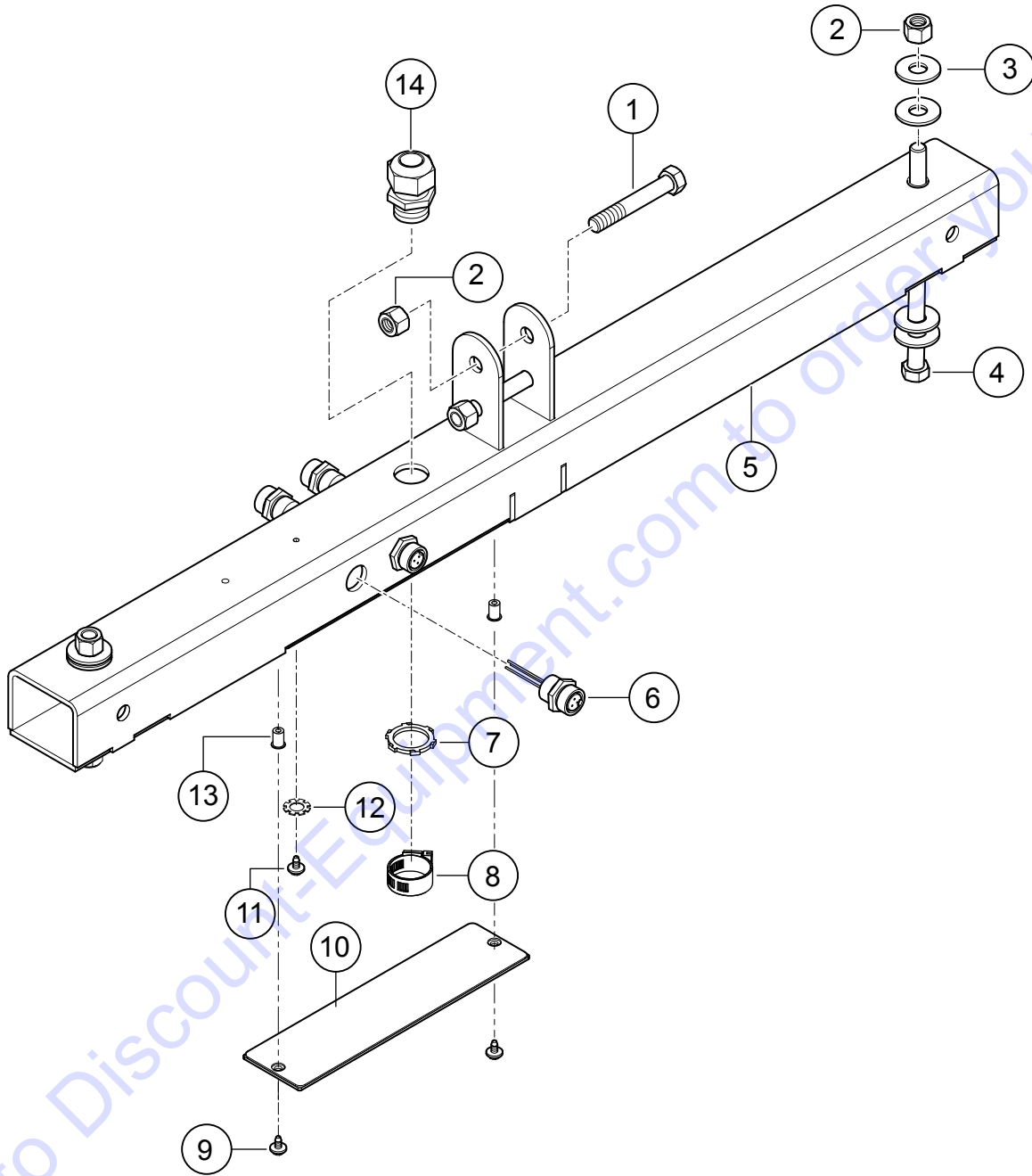

T-BAR ASSY.

<u>NO.</u>	<u>PART NO.</u>	<u>PART NAME</u>	<u>QTY.</u>	<u>REMARKS</u>
1	06503-026	SCREW, HHC 1/2-13 X 3-1/4"	2	
2	10176	NUT, NYLOC 1/2-13	6	
3	13211	WASHER, FLAT 1/2" USS	8	
4	10306	SCREW, HHC 1/2-13 X 4-1/2"	2	
5	34147	T-BAR	1	
6	29168	RECEPTACLE, FEM	4	
7	26560	NUT, LOCKING 3/4 NPT CONDUIT	1	
8	19473	CLAMP, HOSE WORM #2, 1/4" TO 5/8"	1	
9	30119	SCREW, 1/4-20 X 7/8", TYPE 23, ZP, IND HEX. DOG PT.	2	
10	34842	PANEL ASSY. T-BAR ACCESS W/ GASKET	1	
11	34305	SCREW, HHF SLOT, #10-32 X 3/8" TYPE F	1	
12	10237	WASHER, EXT. SHKP, #10	1	
13	19266	NUT, BLIND 1/4-20 X .027-.165	2	
14	29655	CORDGRIP, LIQUID TIGHT, 3/4 NPT	1	

Go to Discount-Equipment.com to order your parts

ENGINE MOUNTING

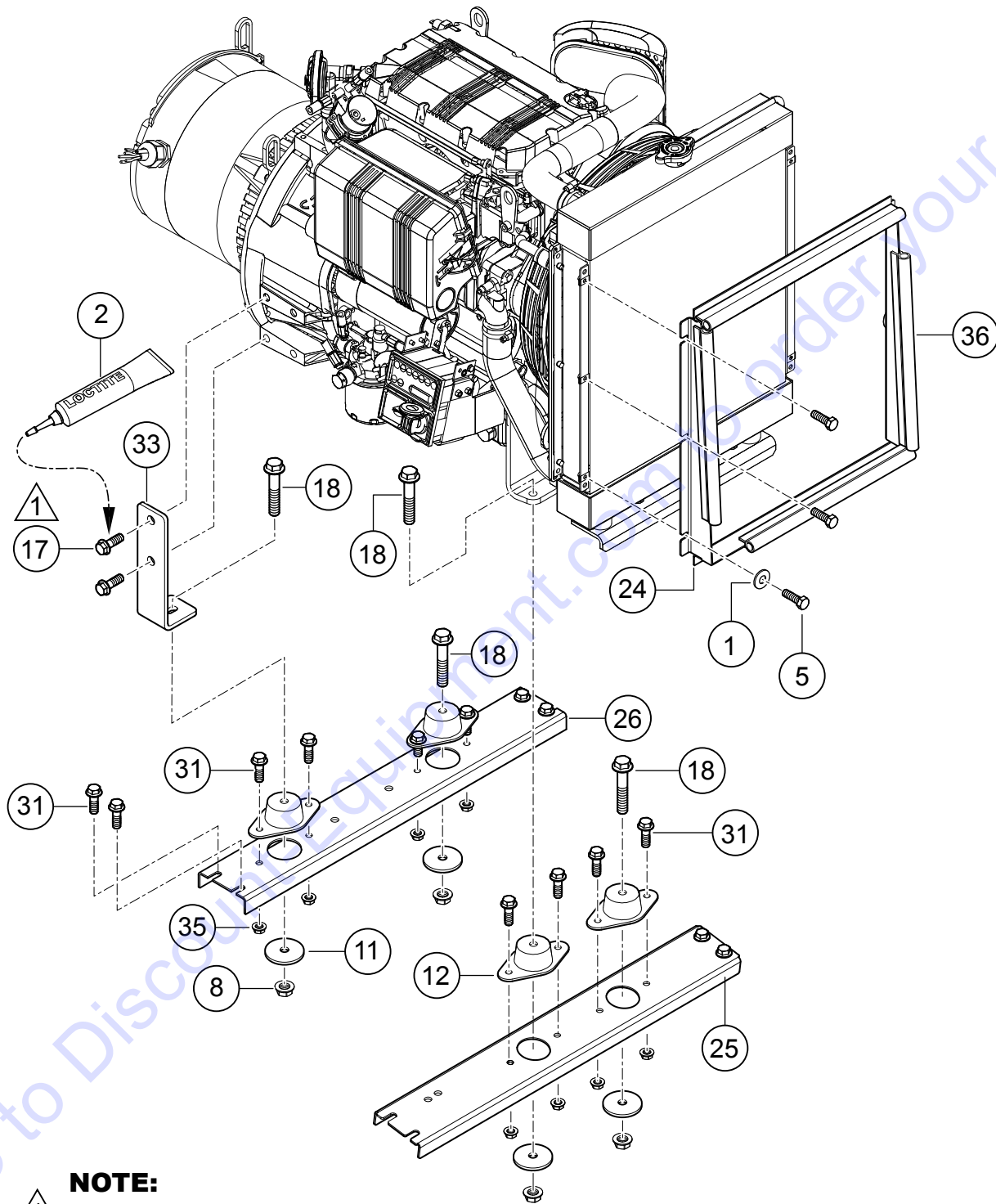

NOTE:
1 APPLY LOCTITE # 271 RED

ENGINE MOUNTING

<u>NO.</u>	<u>PART NO.</u>	<u>PART NAME</u>	<u>QTY.</u>	<u>REMARKS</u>
1	0948	WASHER, FLAT SAE 1/4"	6	
2	19379-014	LOCTITE #271 RED	AR	
5	12464	SCREW, HHC M6-1.0 X 16MM	6	
8	21781	NUT, FLANGED 3/8-16 SERRATED PLTD	4	
11	29043-001	WHEEL, POINTER .41 ID X 2.00 OD	4	
12	29269	MOUNT, VIBRATORY ENGINE	4	
17	34317	SCREW, HHFS M12-1.75 X 20 MM	4	
18	34318	SCREW, HHFS 3/8-16 X 2-1/4"	4	
24	34685	SHROUD, RADIATOR	1	
25	34688	CROSSMEMBER, FRONT	1	
26	34689	CROSSMEMBER, REAR	1	
31	36720	SCREW, HHFS 5/16-18 X 3/4" GRD5	16	
33	49003	MOUNT, REAR ENGINE	2	
35	49071	NUT, FLANGED 5/16-18 SERRATED PLTD	8	
36	60124	GASKET, SPONGE BULB.....	5.....	1PC = 1 FT

ENGINE AND COMPONENTS

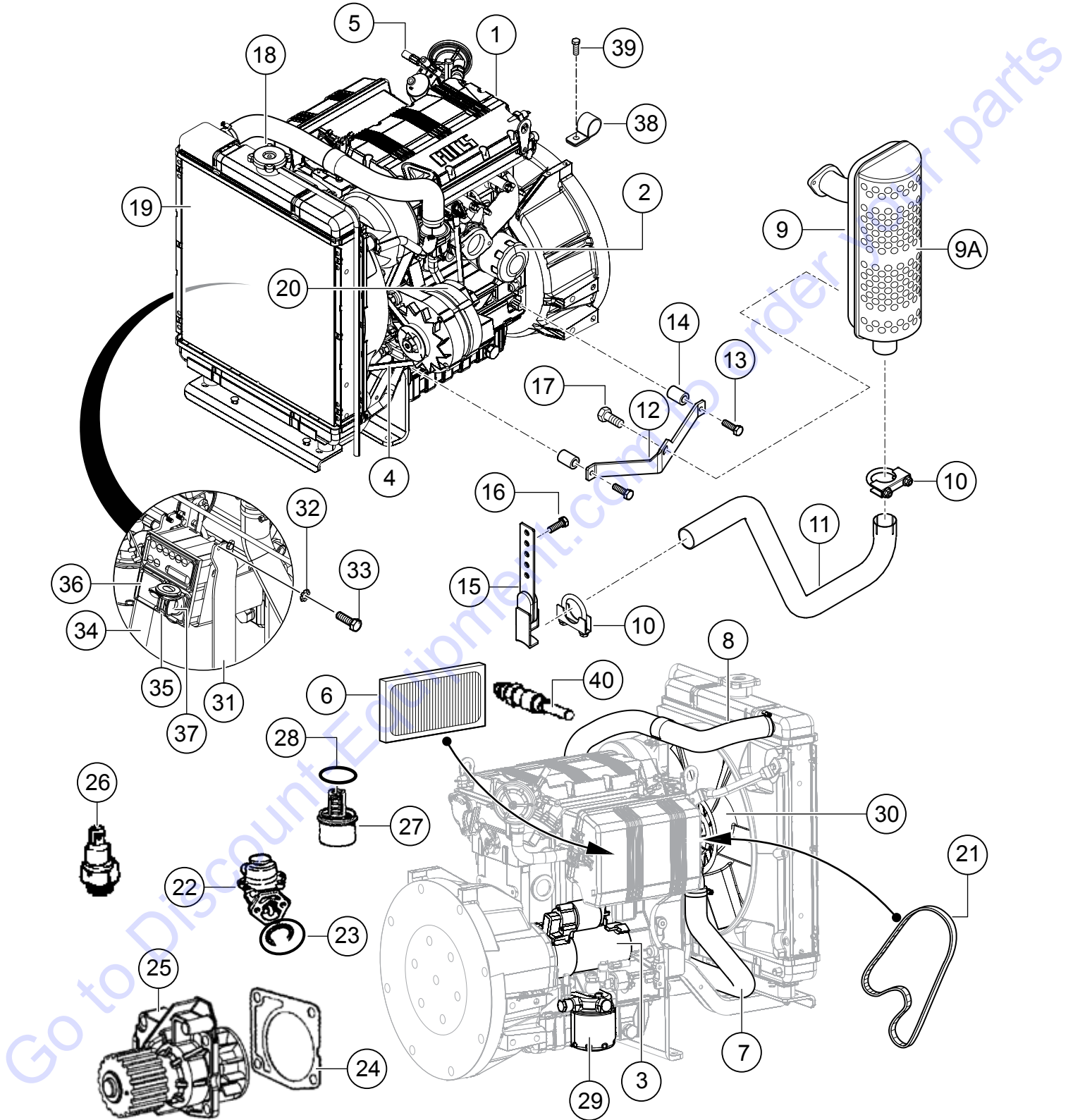

ENGINE AND COMPONENTS

<u>NO.</u>	<u>PART NO.</u>	<u>PART NAME</u>	<u>QTY.</u>	<u>REMARKS</u>
1	29644	ENGINE, KOHLER KDW1003/L FOCS	1	
2	ED0021752830S	OIL FILTER	1	
3	ED0058402240S	STARTER ASSY.	1	
4	ED0024403200S	FAN BELT 835 MM	1	
5	19761	TERMINAL, SPLICE 16-14	1	
6	ED0021751640S	CARTRIDGE, AIR FILTER	1	
7	ED0054011950S	HOSE, RADIATOR, LOWER	1	
8	ED0054011940S	HOSE, RADIATOR, UPPER	1	
9	ED0054604500S	MUFFLER	1	
9A	ED0069271720S	GUARD, MUFFLER	1	
10	10855	CLAMP, 1-1/2" MUFFLER	2	
11	34215	TAIL PIPE EXTENSION	1	
12	29937	BRACE, LOWER MUFFLER	1	
13	23792	SCREW, HHFS M8-1.25 X 30 MM	2	
14	29938	SPACER, MUFFLER BRACKET	2	
15	34335	HANGER, EXHAUST	1	
16	49048	SCREW, HHFS 1/4-20 X 3/4" GRD5	2	
17	2299	BOLT, M8-1.25 X 16 MM	1	
18	ED0090002390S	RADIATOR CAP	1	
19	ED0073503220S	RADIATOR	1	
20	ED0011573910S	ALTERNATOR	1	
21	ED0024403380S	TIMING BELT	1	
22	ED0065851510S	PUMP, FUEL FEED	1	
23	ED0012000870S	O-RING, FEED PUMP	1	
24	ED0065844380S	WATER PUMP	1	
25	ED0045802150S	GASKET, WATER PUMP	1	
26	ED0067450560S	OIL PRESSURE SWITCH	1	
27	ED0091951240S	THERMOSTAT	1	
28	ED0012000910S	O-RING, THERMOSTAT	1	
29	ED0021752880S	FUEL FILTER	1	
30	ED0097183240S	COOLING FAN	1	
31	34814	MOUNT, RIGHT ENG. CONTROL BOX	1	
32	10237	WASHER, EXT. SHKP, #10	4	
33	34823	SCREW, HHC M5-.8 X 12 MM, 8.8 DIN	4	
34	34813	MOUNT, LEFT ENG. CONTROL BOX	1	
35	ED34001S	KEY, IGNITION, DOUBLE SIDED	1	
36	ED0072454650S	CONTROL PANEL	1	
37	ED0050412980S	IGNITION SWITCH	1	
38	8125	CLAMP, HOSE SUPPORT 5/8"	1	
39	22021	SCREW, HEX M8-1.25 X 20 MM GRD10.9	1	
40	ED0021000890S	GLOW PLUG	3	

TUB/TRAILER ASSY.

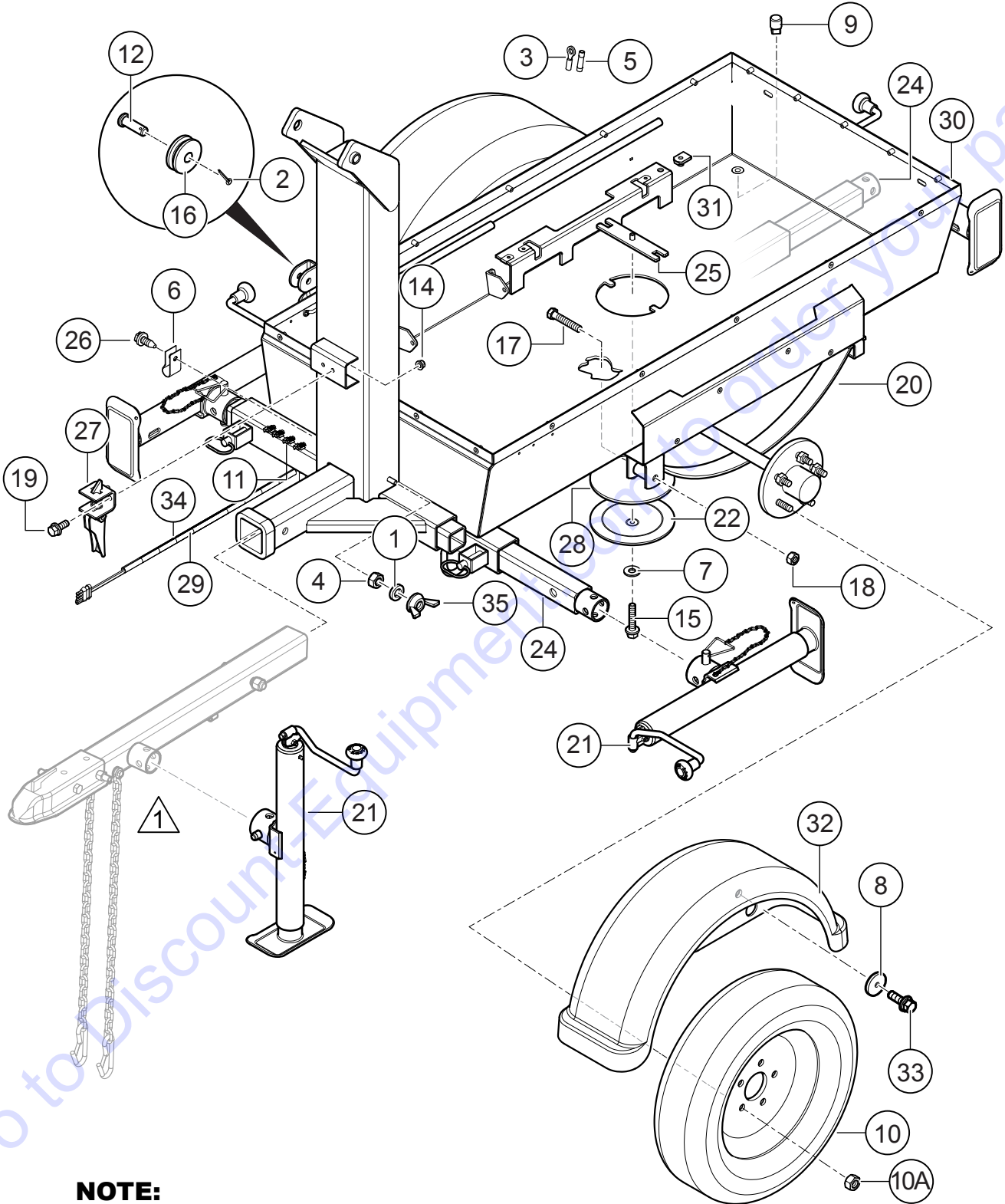

NOTE:

△ 1 SEE TONGUE ASSY. FIGURE

TUB/TRAILER ASSY.

<u>NO.</u>	<u>PART NO.</u>	<u>PART NAME</u>	<u>QTY.</u>	<u>REMARKS</u>
1	0166 A	WASHER, LOCK, 3/8" MED.	1	
2	0183	PIN, COTTER 1/8"D X 1-1/4"	1	
3	1319	TERMINAL, RING 16-14 1/4" LOOP	1	
4	1876	NUT, HEX JAM 3/8-16 CLASS 2B	1	
5	2540	CONNECTOR, BUTT SPLICE, 16-14	1	
6	8126	CLAMP, HOSE 1/2" LOOP X 1/4" HOLE	1	
7	34640	WASHER, SEALING, 5/16 X 3/4	1	
8	10930	WASHER, FENDER, 1/4 X 1-1/4"	8	
9	16185	FITTING, PLUG 1/4MP SQ HD	1	
10	19045	WHEEL/TIRE ST175/80-13 L.R. C 5-LUG	2	
10A	29184	NUT, LUG 1/2-20	10	
11	19761	TERMINAL, SPLICE 16-14 CLOSED, BLUE	4	
12	19974	PIN, CLEVIS 1/2 X 1-1/4" EFF	1	
14	49071	NUT, FLANGED 5/16-18 SERRATED PLTD	2	
15	21906	SCREW, HHFS 5/16-18 X 1-1/2" GRD5	1	
16	29155	SHEAVE, 2.00" OD X 0.50" ID	1	
17	29248	SCREW, HHC 9/16-18 X 3"	2	
18	29249	NUT, 9/16-18 N-2	2	
19	9091	SCREW, HHFS 5/16-18 X 1" GRD5	2	
20	34015	AXLE, ASSY.	1	
21	34093	JACK, 2000#, 10" TOP WIND	4	
22	34101	COVER, ACCESS PANEL	1	
24	34197	OUTRIGGER	3	
25	34213	BRACKET, ACCESS COVER MOUNT	1	
26	34310	SCREW, HHF 1/4 - 20 X 3/8", TYPE 23, ZP	1	
27	34331	LATCH, MAST	1	
28	34378	GASKET, ACCESS COVER	1	
29	34604	HARNES, 25' 4 FLAT TRAILER END	1	
30	34659	TUB/FRAME	1	
31	35358	NUT, "U" TYPE, 5/16-18	24	
32	34720	FENDER	2	
33	49048	SCREW, HHFS 1/4-20 X 3/4" GRD5	8	
34	60221	LOOM, .375 SPLIT	5	1PC = 1 FT
35	W29109	NUT, WING 3/8-16	1	

TONGUE ASSY.

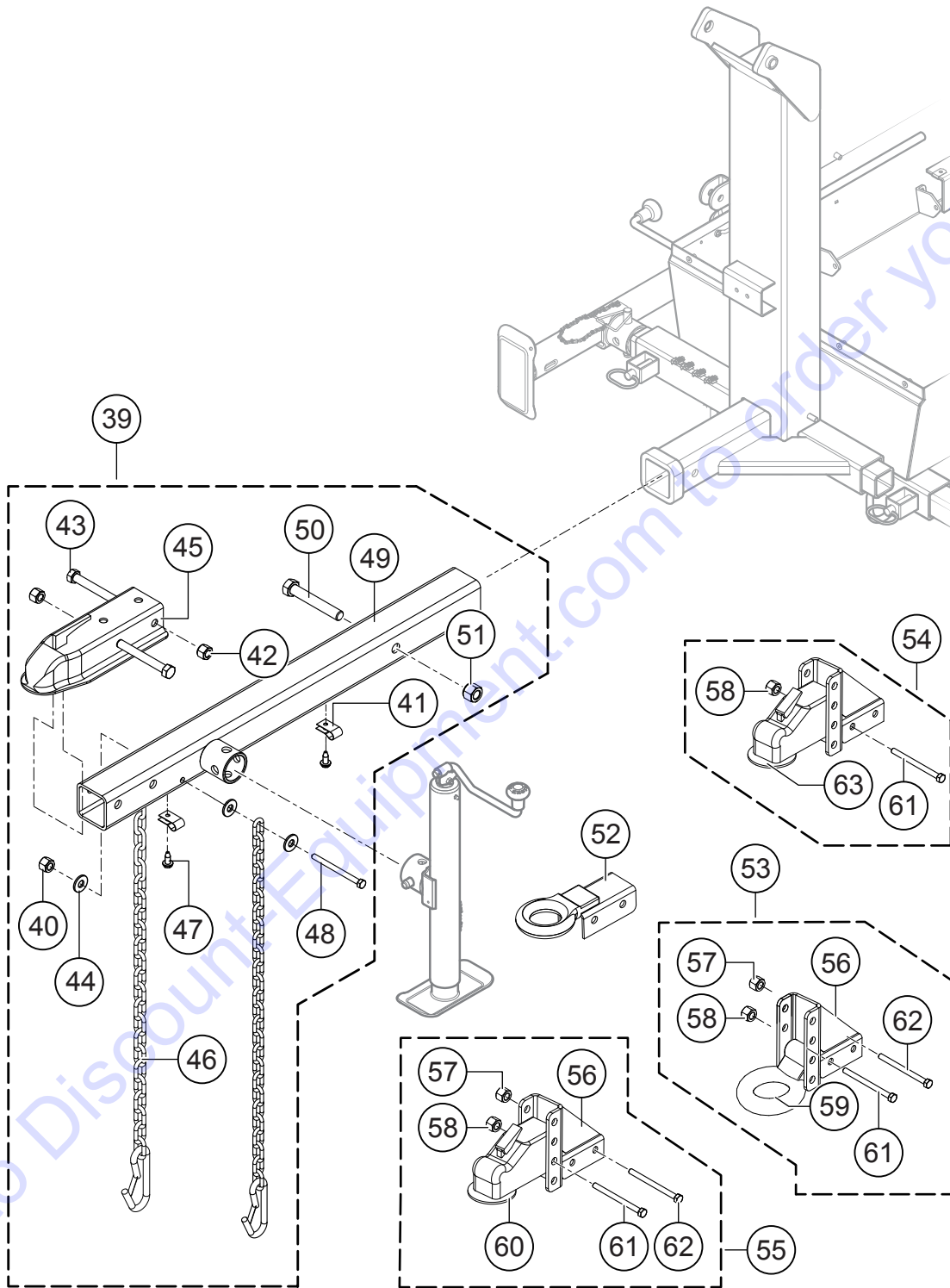

TONGUE ASSY.

<u>NO.</u>	<u>PART NO.</u>	<u>PART NAME</u>	<u>QTY.</u>	<u>REMARKS</u>
39	34681	TOUNGE ASSY.....	1.....	INCLUDES ITEMS W/\$
40\$	5283	NUT, NYLOC 5/16-18	1	
41\$	8126	CLAMP, HOSE 1/2" LOOP X .25" HOLE	2	
42\$	10176	NUT, NYLOC 1/2-13	2	
43\$	16521	SCREW, HHC 1/2-13 X 4" GRD8	2	
44\$	19470	WASHER, FLAT 5/16" USS	4	
45\$	29546	HITCH, 2" BALL, FIXED, (STANDARD)	1	
46\$	34005	CHAIN, SAFETY	2	
47\$	34310	SCREW, HHF, 1/4-20 X 3/8," TYPE 23, ZP	2	
48\$	34370	SCREW, HHC 5/16-18 X 4.0" GRD8	1	
49\$	34680	HITCH TUBE	1	
50\$	915319	SCREW, HHC 5/8-11 X 4" GRD8 YZ	1	
51\$	9503	NUT, NYLOC 5/8-11	1	
52	34953	HITCH, PINTLE FIXED (OPTION)	1	
53	34958	HITCH, PINTLE, KIT, HT. ADJ. (OPTION)	1.....	INCLUDESITEMSW/@
54	34959	HITCH, 2" BALL, KIT, HT. ADJ. (OPTION).....	1.....	INCLUDESITEMSW/%
55	34960	HITCH, 2-5/16" BALL, KIT, HT. ADJ. (OPTION).....	1.....	INCLUDES ITEMS W/#
56#@	29718	COUPLER ADAPTER	1	
57#@	10176	NUT, NYLOC 1/2-13	2	
58#%@	9503	NUT, NYLOC 5/8-11	2	
59@	29369	PINTLE EYE, ADJUSTABLE	1	
60#	34811	COUPLER, 2-5/16" BALL, ADJUSTABLE	1	
61#%@	915218	SCREW, HHC 1/2-13 X 3-3/4" GRD8	2	
62#@	9502	SCREW, HHC 5/8-11 X 4-1/2" GRD8	2	
63%	29228	COUPLER, 2" BALL, ADJUSTABLE	1	

JACK ASSY.

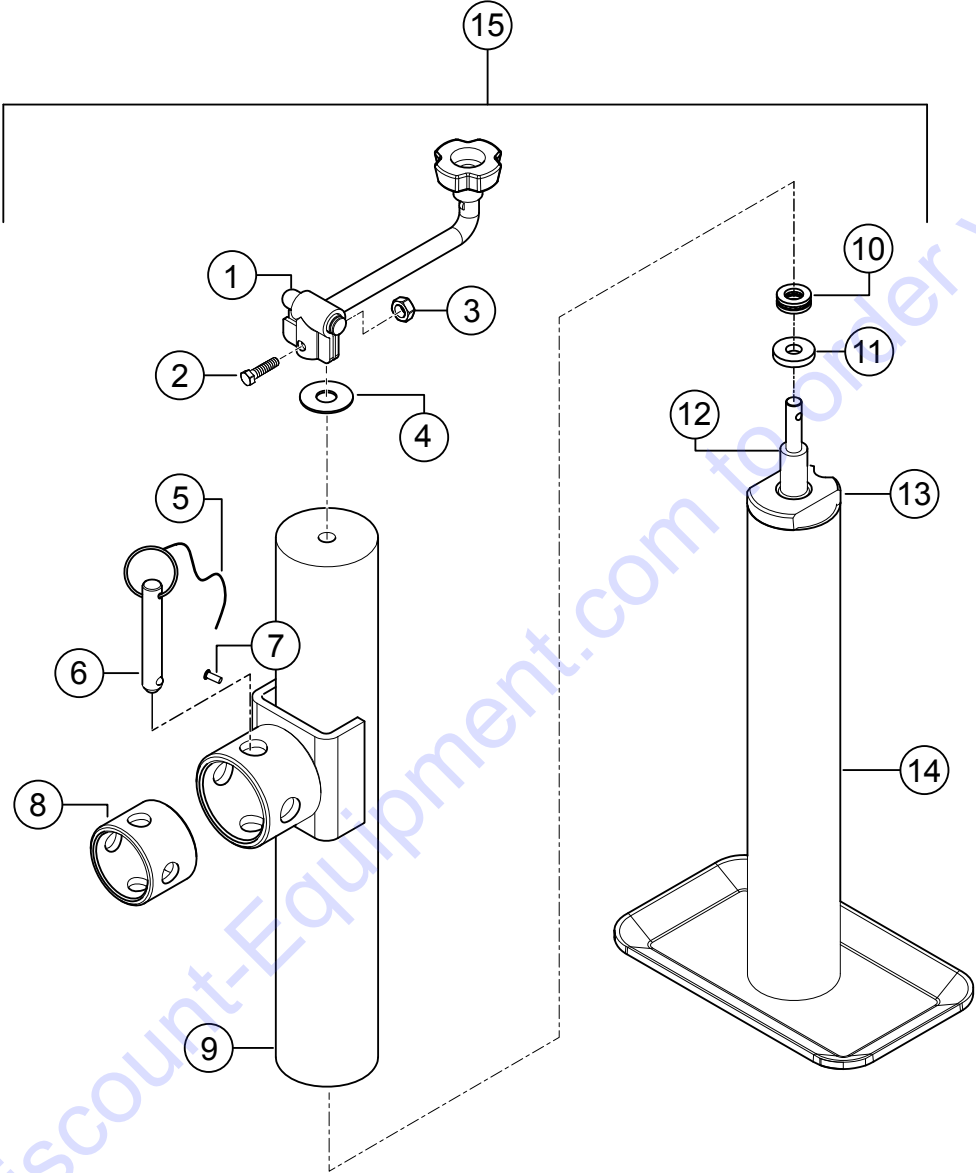

JACK ASSY.

<u>NO.</u>	<u>PART NO.</u>	<u>PART NAME</u>	<u>QTY.</u>	<u>REMARKS</u>
1	345109-01	HANDLE ASSEMBLY	1	
2	345109-02	BOLT M6X28	1	
3	345109-03	LOCK NUT M6	1	
4	345109-04	WASHER	1	
5	345109-05	CHAIN	1	
6	345109-06	PIN	1	
7	345109-07	CHAIN RIVET	1	
8	345109-08	MALE MOUNT TUBE	1	
9	345109-09	OUTER TUBE ASSEMBLY	1	
10	345109-10	BEARING	1	
11	345109-11	HEATED WASHER	1	
12	345109-12	THREAD	1	
13	345109-13	MAIN NUT	1	
14	345109-14	INNER TUBE	1	
15	34093	JACK ASSY., 2000 LBS, 10" TOP WIND	1	

Go to Discount-Equipment.com to order your parts

GENERATOR ASSY.

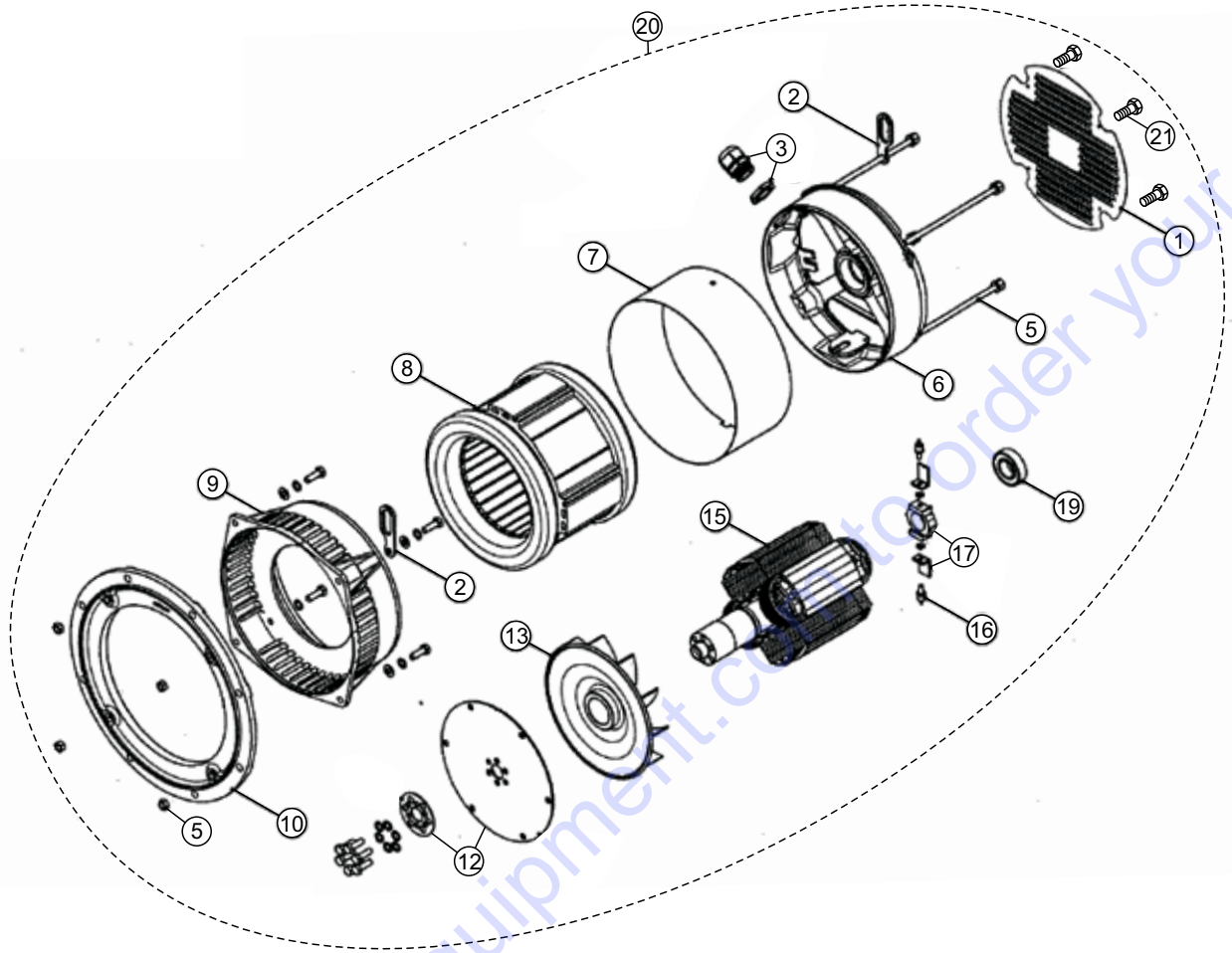

GENERATOR ASSY.

<u>NO.</u>	<u>PART NO.</u>	<u>PART NAME</u>	<u>QTY.</u>	<u>REMARKS</u>
1%	GELT3GRID	REAR SEAL	1	
2%	GELT3LIFTHK	LIFTING HOOK	2	
3%	GELT3CABLEGPG21	PG21 CABLE GLAND AND NUT	1	
5%	GELT3CSBOLTS	COVER STAY BOLT AND NUT	4	
6%	GELT3NDEBRACKET	NON-DRIVE END BRACKET	1	
7%	GELT3110ENCBAND	ENCLOSING BAND	1	
8%	GELT3110STATOR50	WOUND STATOR AND FRAME	1	
9%	GELT3DEBRACKET	DRIVE END BRACKET	1	
10%	6102208193	INTERCHANGEABLE FLANGE	1	
12%	GEECO3DISC65	FLEXIBLE DISC AND RING SPACER	1	
13%	GELT3FAN	FAN	1	
15%	GELT3110ROTOR50	ROTOR ASSY	1	
16%	GEDIO160026	DIODES	2	
17%	GELT3DIOHSINK	HEAT SINK/SUPPORT, ROTATING DIODE BRIDGE	2	
19%	GEBRG6205LL	REAR BEARING 6205-2RS	1	
20	49126	GENERATOR, 50 HZ.....	1INCLUDES ITEMS W/%
21%	29895SCREW	COVER SCREWS, SET OF 3	1	

BATTERY ASSY.

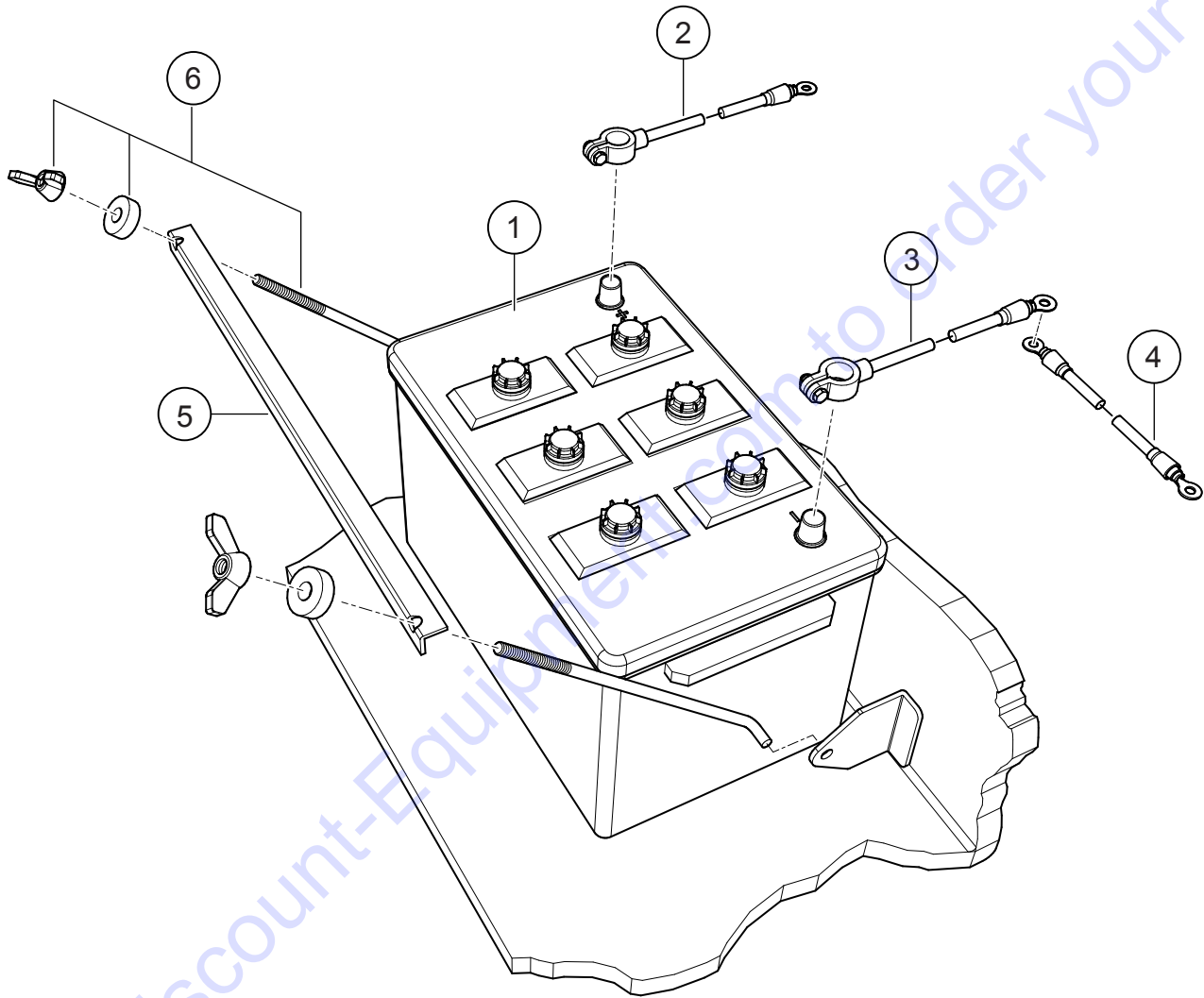

BATTERY ASSY.

<u>NO.</u>	<u>PART NO.</u>	<u>PART NAME</u>	<u>QTY.</u>	<u>REMARKS</u>
1	10315	BATTERY, 12V GROUP 24 WET	1	
2	34393	CABLE, BATTERY POS 4GA X 48" POST	1	
3	34392	CABLE, BATTERY NEG 6GA X 20" POST	1	
4	34394	CABLE, BATTERY CHASSIS GROUND	1	
5	34759	BATTERY HOLD DOWN	1	
6	34900	BOLT-J, W/ HDWR	2	

Go to Discount-Equipment.com to order your parts

COIL CORD ASSY.

CONNECT TO T-BAR ASSEMBLY

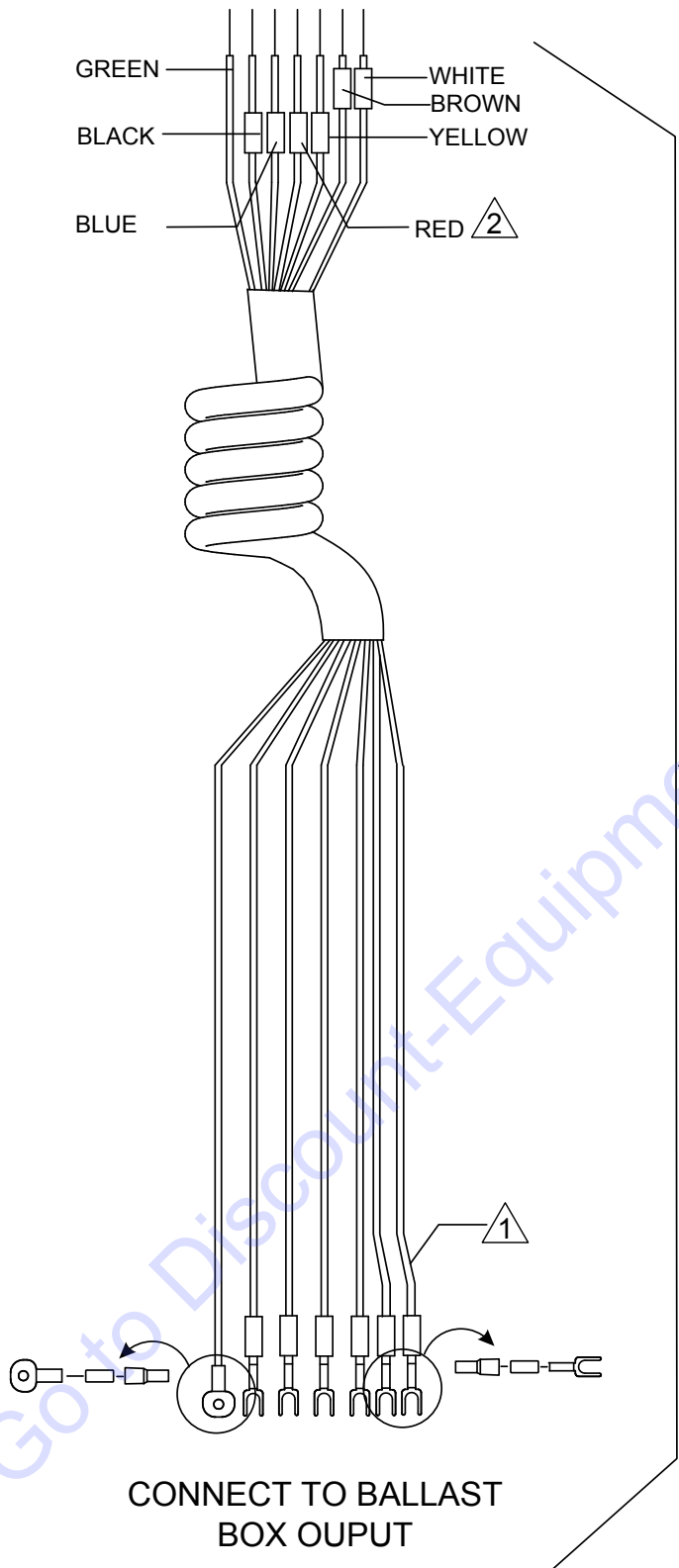

CONNECT TO BALLAST BOX OUTPUT

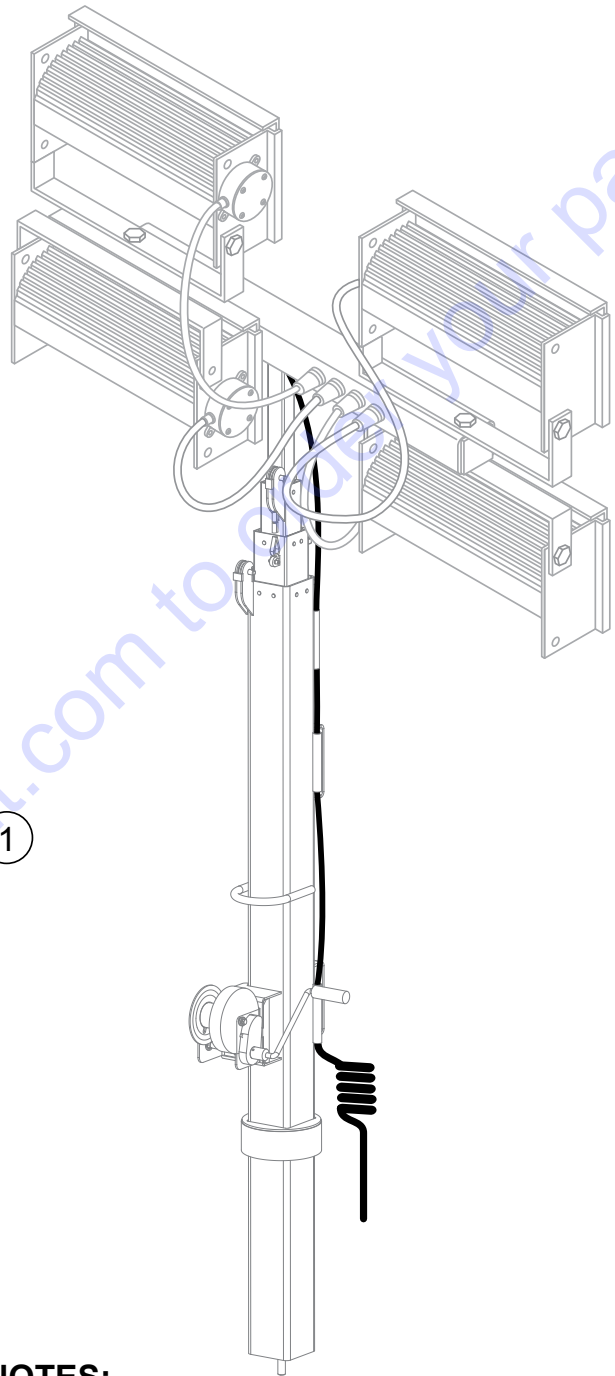

NOTES:

- ① CONNECT THIS END OF COIL CORD ASSY. TO BALLAST BOX. REFERENCE ELECTRICAL SCHEMATIC DIAGRAM IN OPERATION MANUAL.
- ② CONNECT THIS END OF COIL CORD ASSY. TO T-BAR ASSY. REFERENCE ELECTRICAL SCHEMATIC DIAGRAM IN OPERATION MANUAL.

COIL CORD ASSY.

<u>NO.</u>	<u>PART NO.</u>	<u>PART NAME</u>	<u>QTY.</u>	<u>REMARKS</u>
1	34880	COIL CORD ASSY.....	1	INCLUDES ITEMS W/#

Go to Discount-Equipment.com to order your parts

LAMP ASSY.

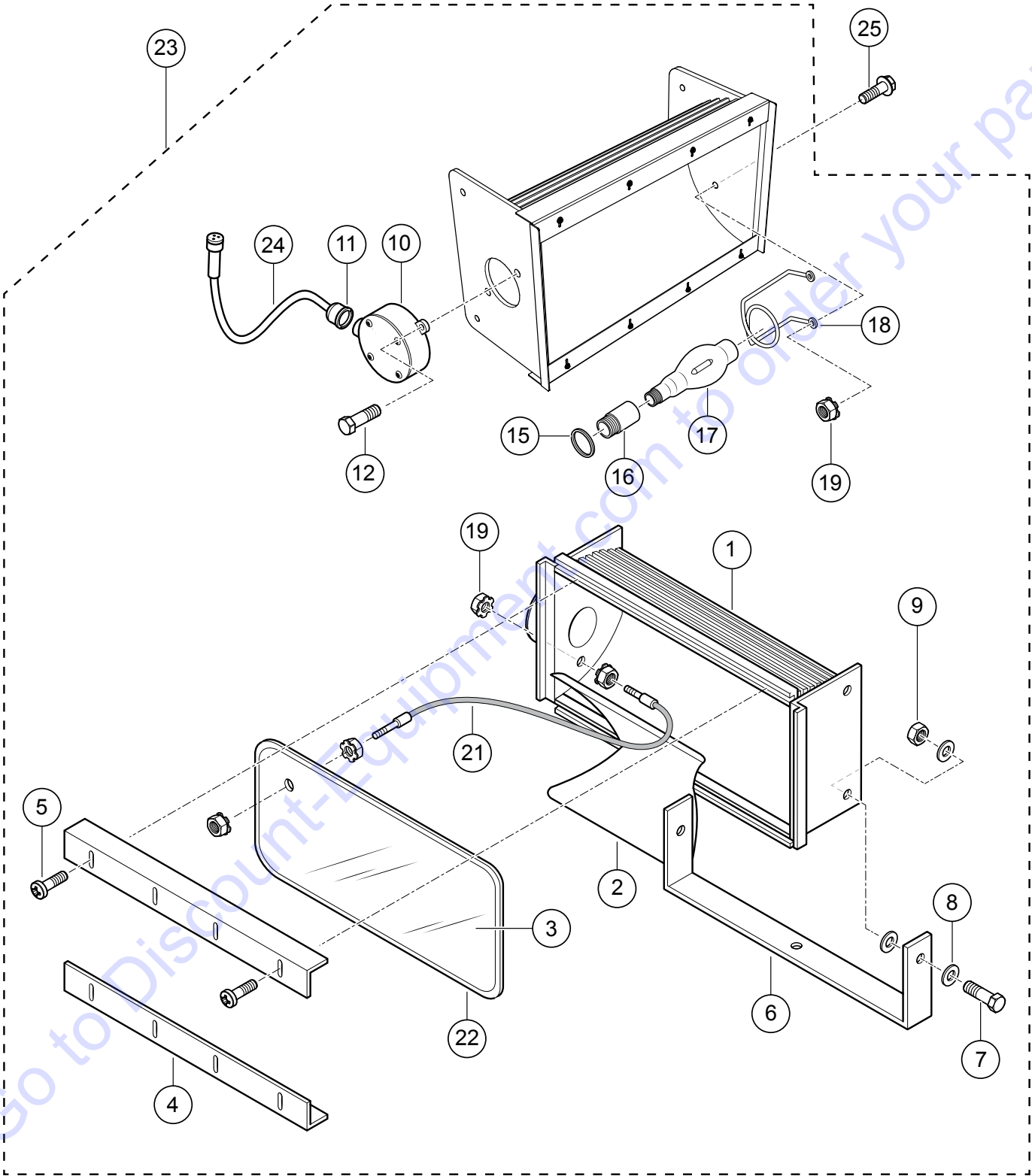

LAMP ASSY.

<u>NO.</u>	<u>PART NO.</u>	<u>PART NAME</u>	<u>QTY.</u>	<u>REMARKS</u>
1%	20S-REF-1	REF1000 BODY ASSY.	1	
2%	30M-REF-REF	REFLECTOR, ALUMINUM	1	
3%	190ZQREF	REF 1000 LENS	1	
4%	170M-REF-5	REF LENS HOLD DOWN	2	
5%	70Z-FSCR3	SCREW 8-32 X 1/2"	8	
6%	250-REF-6	YOKE, LIGHT FIXTURE	1	
7%	260Z-FSCR9	BOLT, HEX HEAD 1/2-13 x 1-1/2"	2	
8%	280Z-FWFL2	WASHER, FLAT 1/2"	4	
9%	270Z-FNT4	NUT, HEX 1/2-13	2	
10%	Z-C-239	VAPORTITE OCTAGON BOX 1/2" W/4 THREADED PLUGS G9 SILVER	1	
11%	150Z-FSR3	STRAIN RELIEF SRW 1/2" BLACK	1	
12%	Z-FSCR9	BOLT, HEX HD, 1/2-13 X 1-1/2" ZN PLT.	2	
15%	90Z-G-102	GASKET, HEX #5 OR #6	1	
16%	70Z-SK65	SOCKET, MOGUL W/GASKET	1	
17%	MVR1000BT37	BULB, LIGHT FIXTURE	1	
18%	50Z-D-REF-SUP	SUPPORT, REF1000 LAMP TIP	1	
19%	230Z-FNTL6-1	KEEPER NUT #8-32	6	
21%	210S-CBL-6	CABLE ASSEMBLY	1	
22%	200ZG106	GASKET, U-CHANNEL REFLECTOR	1	
23	29773	LIGHT FIXTURE ASSY.....	1	INCLUDES ITEMS W/%
24%	150Z-EZ67	POWER CORD, 60" W/ 3-PIN MALE PLUG	1	
25	4106781000	SCREW, 8-32 X 3/8"	2	

CONTROL PANEL ASSY.

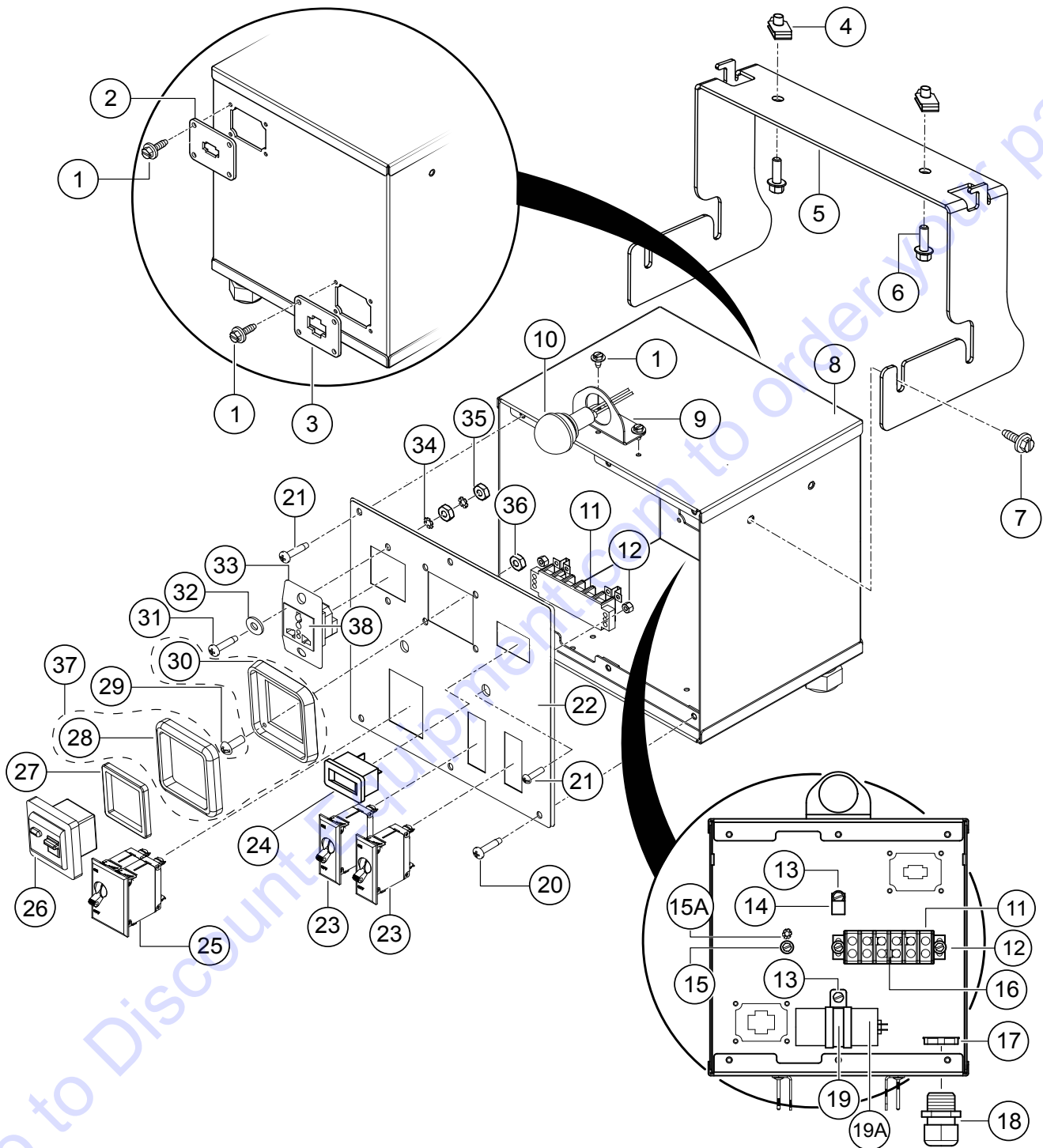

CONTROL PANEL ASSY.

<u>NO.</u>	<u>PART NO.</u>	<u>PART NAME</u>	<u>QTY.</u>	<u>REMARKS</u>
1	34309	SCREW, HHF SLOT #10-32 X 3/8", TYPE F, ZP	10	
2	34328	MOLEX 2 PLC MTG. PLATE	1	
3	34927	MOLEX 6 PLC MTG. PLATE	1	
4	11534	NUT, "U" TYPE, 1/4-20	2	
5	34758	BRACKET, CONTROL BOX MOUNTING	1	
6	49048	SCREW, HHFS 1/4-20 X 3/4" GRD5	2	
7	34307	SCREW, HHF SLOT, 1/4-20 X 5/8", TYPE 23, ZP	4	
8	34167	CONTROL BOX W/A, LIGHT TOWER	1	
9	34358	MOUNT, COURTESY LAMP	1	
10	34347	LAMP, COMPACT COURTESY, 2 WIRE	1	
11	34804	TERMINAL STRIP, 6 GANG, 2 ROW #10	1	
12	10019	NUT NYLOC #10-32	2	
13	34310	SCREW, HHF 1/4-20 X 3/8", TYPE 23, ZP	2	
14	11505	CLAMP, HOSE SUPT. 1/2" L	1	
15	34305	SCREW, HHF SLOT #10-32 X 3/8", TYPE F, GRN ZN	1	
15A	10237	WASHER, EXT. SHKP, #10	1	
16	34833	JUMPER, T8345 TERMINAL BLOCK, #10 SCREW	1	
17	26560	NUT, LOCKING 3/4 PT	1	
18	29655	CORDGRIP, LIQUID TIGHT, 3/4 NPT	1	
19	59017	CLAMP, CUSH. LOOP, 2.16" DIA X .53"	1	
19A	59018	EXCITATION CAPACITOR, 50HZ, 35 mF	1	
20	34306	SCREW, PHP #10-32 X 5/8", TYPE F, ZP	6	
21	8133	SCREW, PHP 10-32 X 3/4"	2	
22	34786	CONTROL PANEL	1	
23	34098	CIRCUIT BREAKER, 15A	2	
24	29640	HOUR METER, SENDEC RECT FLUSH MOUNT	1	
25	34096	CIRCUIT BREAKER, 30A	1	
26	34846	BREAKER, GFCI, 230V, 50HZ	1	
27	34848	COVER FRAME, 230V GFCI BREAKER	1	
28	34847B	COVER FRAME, GFCI BREAKER	1	
29	19298	SCREW, PHP 6-32 X 3/8	4	
30	34847A	MOUNT FRAME, GFCI BREAKER	1	
31	15175	SCREW, PAN HEAD 8-32 X 3/4	2	
32	15173	WASHER, FLAT, #8	2	
33	34838	MOUNT PLATE, 50 HZ RECEPTACLE	1	
34	10114	WASHER, EXT. SHKP, #8	3	
35	16723	NUT, HEX FIN 8-32	3	
36	11152	NUT, NYLOC 6-32	4	
37	34847	FRAME, PANEL MOUNT	1	
38	34839	RECEPTACLE, 50HZ, UNIVERSAL	1	

FUEL TANK, HOSES AND MOUNTING ASSY.

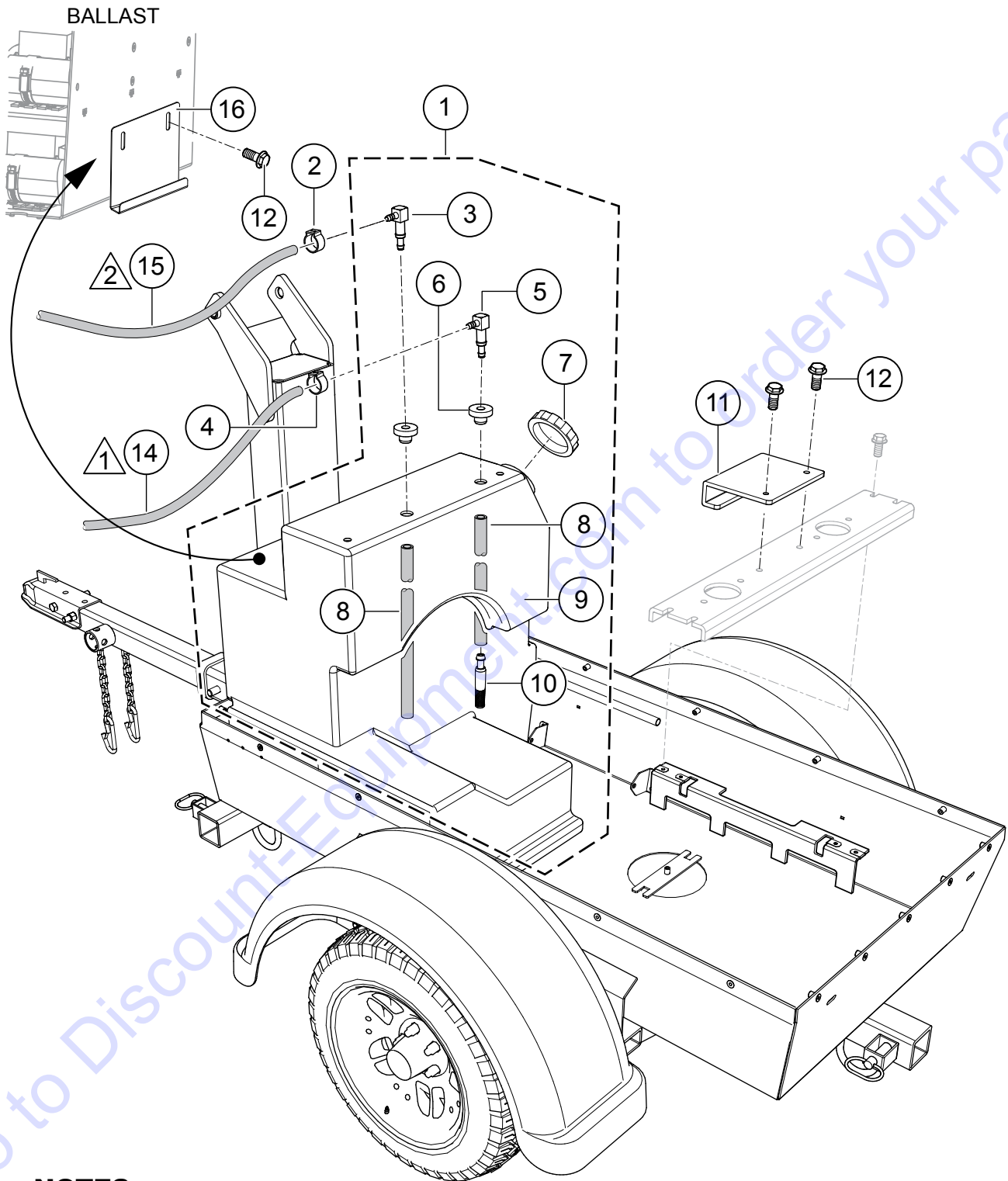

NOTES:

- ① CONNECTS TO FUEL PUMP **SUCTION SIDE**
- ② CONNECTS TO **FUEL RETURN**

FUEL TANK, HOSES AND MOUNTING ASSY.

<u>NO.</u>	<u>PART NO.</u>	<u>PART NAME</u>	<u>QTY.</u>	<u>REMARKS</u>
1	34738	FUEL TANK ASSY.....	1.....	INCLUDES ITEMS W/\$
2	22066	CLAMP, STEPLESS EAR 3/16" HOSE	1	
3\$	12007	FITTING, 90° 4SBARB X 6-4SBARB	1	
4	22067	CLAMP, STEPLESS EAR 1/4" HOSE	1	
5\$	12006	FITTING, 90° 3MBARB X 6-4SBARB	1	
6\$	19633	BUSHING, RUBBER FUEL	2	
7\$	29694	CAP, FUEL W/LANYARD, KELCH 3-1/2"	1	
8\$	60058	HOSE, .25 YELLOW PVC, 30" L EACH.....	5.....	1PC = 1FT
9\$	34719	TANK, FUEL	1	
10\$	12009	FILTER, IN-TANK	1	
11	34716	BRACKET, FUEL TANK, LOWER	1	
12	49048	SCREW, HHFS 1/4-20 X 3/4" GRD5	4	
14	60013	HOSE, FUEL Ø.250 LOW PERM 50 PSI	3.....	1PC = 1FT
15	60004	HOSE, FUEL Ø.1875 LOW PERM 50 PSI 5.5'..	6.....	1PC = 1FT
16	34836	BRACKET, FUEL TANK, UPPER	1	

Go to Discount-Equipment.com to order your parts

HARNES ASSY.

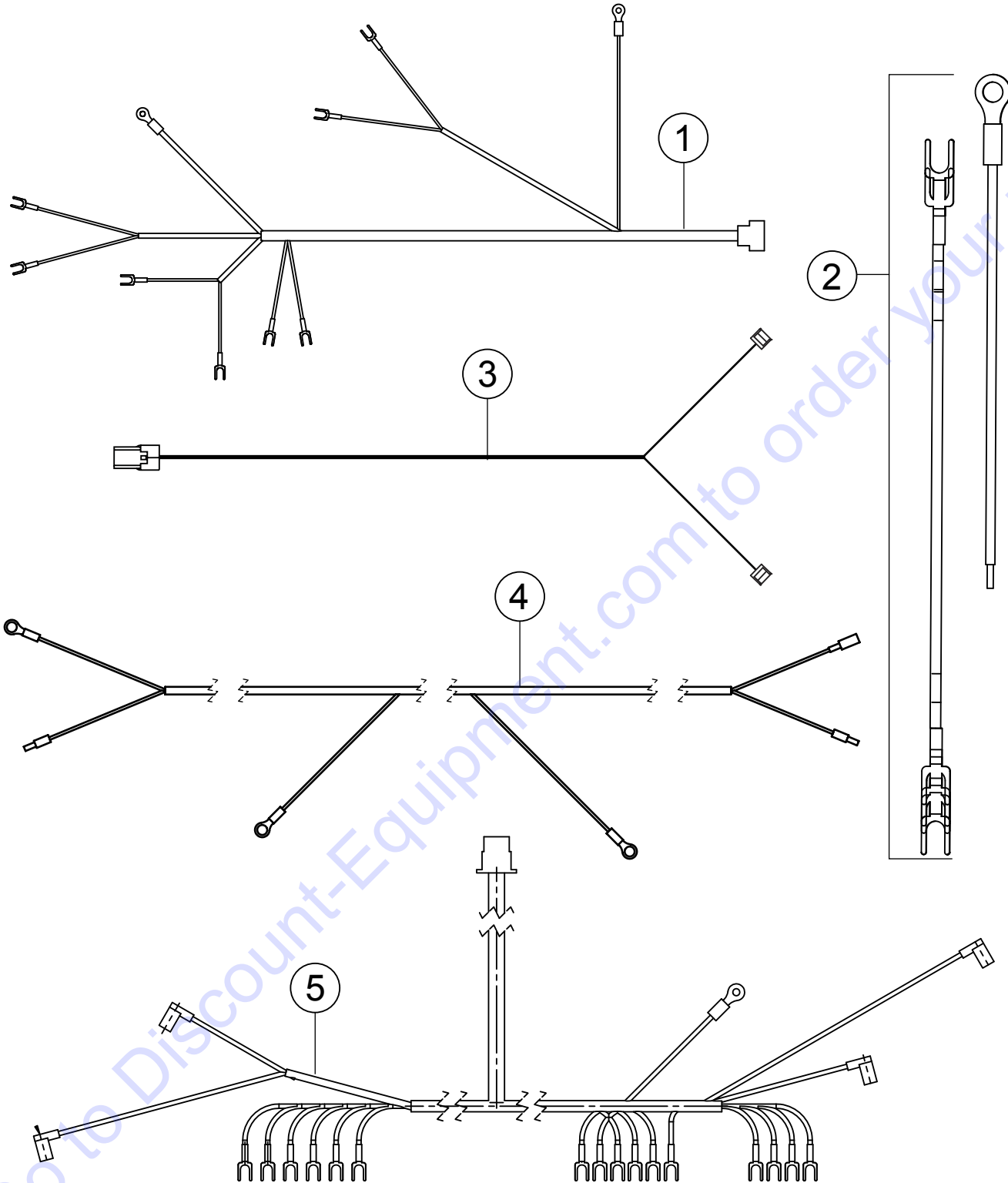

HARNES ASSY.

<u>NO.</u>	<u>PART NO.</u>	<u>PART NAME</u>	<u>QTY.</u>	<u>REMARKS</u>
1	34870	HARNES, LT6K5 A/C CONTROLS	1	
2	34869	KIT, LT6K5 AC JUMPER WIRES	1	
3	34381	HARNES, HR METER, INT, LT6D	1	
4	34799	HARNES, COURTESY LIGHT	1	
5	34835	HARNES, BALLAST	1	

Go to Discount-Equipment.com to order your parts

PARTS FINDER

**Search Website
by Part Number**



**Search Manual
Library For Parts
Manual & Lookup Part
Numbers – Purchase
or Request Quote**

Search Manuals

Enter your information to help us find the right parts manual for your machine.

* Brand:

* Model:

* Serial:

* Part Number:

SEARCH

**Can't Find Part or
Manual? Request Help
by Manufacturer,
Model & Description**

Parts Order Form

Please fill in the following information to help us find the right part for your machine.

Manufacturer:	<input type="text"/>
Model:	<input type="text"/>
Description:	<input type="text"/>
Part Number:	<input type="text"/>
Quantity:	<input type="text"/>
Notes:	<input type="text"/>

Submit

Discount-Equipment.com is your online resource for quality parts & equipment.

Florida: **561-964-4949** Outside Florida TOLL FREE: **877-690-3101**

Need parts?

Click on this link: <http://www.discount-equipment.com/category/5443-parts/> and choose one of the options to help get the right parts and equipment you are looking for. Please have the machine model and serial number available in order to help us get you the correct parts. If you don't find the part on the website or on one of the online manuals, please fill out the request form and one of our experienced staff members will get back to you with a quote for the right part that your machine needs.

We sell worldwide for the brands: Genie, Terex, JLG, MultiQuip, Mikasa, Essick, Whiteman, Mayco, Toro Stone, Diamond Products, Generac Magnum, Airman, Haulotte, Barreto, Power Blanket, Nifty Lift, Atlas Copco, Chicago Pneumatic, Allmand, Miller Curber, Skyjack, Lull, Skytrak, Tsurumi, Husquvarna Target, Stow, Wacker, Sakai, Mi-T-M, Sullair, Basic, Dynapac, MBW, Weber, Bartell, Bennar Newman, Haulotte, Ditch Runner, Menegotti, Morrison, Contec, Buddy, Crown, Edco, Wyco, Bomag, Laymor, EZ Trench, Bil-Jax, F.S. Curtis, Gehl Pavers, Heli, Honda, ICS/PowerGrit, IHI, Partner, Imer, Clipper, MMD, Koshin, Rice, CH&E, General Equipment, Amida, Coleman, NAC, Gradall, Square Shooter, Kent, Stanley, Tamco, Toku, Hatz, Kohler, Robin, Wisconsin, Northrock, Oztec, Toker TK, Rol-Air, APT, Wylie, Ingersoll Rand / Doosan, Innovatech, Con X, Ammann, Mecalac, Makinex, Smith Surface Prep, Small Line, Wanco, Yanmar