

**OPERATION AND PARTS MANUAL**



**MULTIQUIP/STOW  
MODEL BP-25H  
GASOLINE BACKPACK  
VIBRATOR**

**(HONDA GXH50QXA GASOLINE ENGINE)**

Revision #7 (12/19/07)

THIS MANUAL MUST ACCOMPANY THE EQUIPMENT AT ALL TIMES.

# PARTS FINDER

**Search Website  
by Part Number**



**Search Manual  
Library For Parts  
Manual & Lookup Part  
Numbers – Purchase  
or Request Quote**

**Search Manuals**

Enter your information to help us find the right parts manual for your machine.

\* Brand:

\* Model:

\* Serial:

\* Part Number:

SEARCH

**Can't Find Part or  
Manual? Request Help  
by Manufacturer,  
Model & Description**

**Parts Order Form**

Please fill in the following information to help us find the right part for your machine.

Manufacturer:	<input type="text"/>
Model:	<input type="text"/>
Description:	<input type="text"/>
Part Number:	<input type="text"/>
Quantity:	<input type="text"/>
Notes:	<input type="text"/>

REQUEST HELP

Discount-Equipment.com is your online resource for quality parts & equipment.

Florida: **561-964-4949** Outside Florida TOLL FREE: **877-690-3101**

**Need parts?**

Click on this link: <http://www.discount-equipment.com/category/5443-parts/> and choose one of the options to help get the right parts and equipment you are looking for. Please have the machine model and serial number available in order to help us get you the correct parts. If you don't find the part on the website or on one of the online manuals, please fill out the request form and one of our experienced staff members will get back to you with a quote for the right part that your machine needs.

We sell worldwide for the brands: Genie, Terex, JLG, MultiQuip, Mikasa, Essick, Whiteman, Mayco, Toro Stone, Diamond Products, Generac Magnum, Airman, Haulotte, Barreto, Power Blanket, Nifty Lift, Atlas Copco, Chicago Pneumatic, Allmand, Miller Curber, Skyjack, Lull, Skytrak, Tsurumi, Husquvarna Target, Stow, Wacker, Sakai, Mi-T-M, Sullair, Basic, Dynapac, MBW, Weber, Bartell, Bennar Newman, Haulotte, Ditch Runner, Menegotti, Morrison, Contec, Buddy, Crown, Edco, Wyco, Bomag, Laymor, EZ Trench, Bil-Jax, F.S. Curtis, Gehl Pavers, Heli, Honda, ICS/PowerGrit, IHI, Partner, Imer, Clipper, MMD, Koshin, Rice, CH&E, General Equipment, Amida, Coleman, NAC, Gradall, Square Shooter, Kent, Stanley, Tamco, Toku, Hatz, Kohler, Robin, Wisconsin, Northrock, Oztec, Toker TK, Rol-Air, APT, Wylie, Ingersoll Rand / Doosan, Innovatech, Con X, Ammann, Mecalac, Makinex, Smith Surface Prep, Small Line, Wanco, Yanmar

 **WARNING** 

**CALIFORNIA — Proposition 65 Warning**

Engine exhaust and some of its constituents, and some dust created by power sanding, sawing, grinding, drilling and other construction activities contains chemicals known to the State of California to cause cancer, birth defects and other reproductive harm. Some examples of these chemicals are:

- Lead from lead-based paints.
- Crystalline silica from bricks.
- Cement and other masonry products.
- Arsenic and chromium from chemically treated lumber.

Your risk from these exposures varies, depending on how often you do this type of work. To reduce your exposure to these chemicals: **ALWAYS** work in a well ventilated area, and work with approved safety equipment, such as dust masks that are specially designed to filter out microscopic particles.

**! WARNING**



**SILICOSIS WARNING**

Grinding/cutting/drilling of masonry, concrete, metal and other materials with silica in their composition may give off dust or mists containing crystalline silica. Silica is a basic component of sand, quartz, brick clay, granite and numerous other minerals and rocks. Repeated and/or substantial inhalation of airborne crystalline silica can cause serious or fatal respiratory diseases, including silicosis. In addition, California and some other authorities have listed respirable crystalline silica as a substance known to cause cancer. When cutting such materials, always follow the respiratory precautions mentioned above.

**! WARNING**

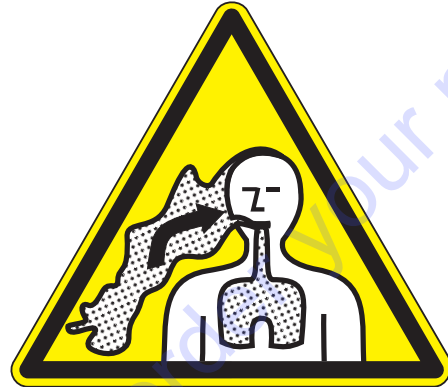

**RESPIRATORY HAZARDS**

Grinding/cutting/drilling of masonry, concrete, metal and other materials can generate dust, mists and fumes containing chemicals known to cause serious or fatal injury or illness, such as respiratory disease, cancer, birth defects or other reproductive harm. If you are unfamiliar with the risks associated with the particular process and/or material being cut or the composition of the tool being used, review the material safety data sheet and/or consult your employer, the material manufacturer/supplier, governmental agencies such as OSHA and NIOSH and other sources on hazardous materials. California and some other authorities, for instance, have published lists of substances known to cause cancer, reproductive toxicity, or other harmful effects.

Control dust, mist and fumes at the source where possible. In this regard use good work practices and follow the recommendations of the manufacturers or suppliers, OSHA/NIOSH, and occupational and trade associations. Water should be used for dust suppression when wet cutting is feasible. When the hazards from inhalation of dust, mists and fumes cannot be eliminated, the operator and any bystanders should always wear a respirator approved by NIOSH/MSHA for the materials being used.

# BP-25H GASOLINE VIBRATOR — TABLE OF CONTENTS

## Multiquip BP-25H Concrete Gasoline Vibrator

Proposition 65 Warning .....	2
Silicosis/Respiratory Warnings .....	3
Table of Contents .....	4
Parts Ordering Procedures .....	5
Specifications (Engine) .....	7
Dimensions .....	8
Safety Message Alert Symbols .....	9-10
Rules For Safe Operation .....	11-12
General Information .....	13
Vibrator Components .....	14
Engine Components .....	15
Pre-Inspection (Engine) .....	16
Head and Shaft Selections .....	17
Head and Shaft Connections .....	18-19
Protective Sleeve Installation .....	20
Initial Start-up (Engine) .....	21
Operation .....	22
Engine Shutdown .....	23
Maintenance (Engine) .....	24-26
Preparation for Long-Term Storage .....	27
Troubleshooting (Engine) .....	28-29
Explanation of Code in Remarks .....	30
Suggested Spare Parts .....	31

## Component Drawing

Nameplate and Decals .....	32-33
Vibrator Assembly .....	34-35
Frame Assembly .....	36-37

## Honda GXH50QXA Engine

Air Cleaner Assembly .....	38-39
Camshaft Assembly .....	40-41
Carburetor Assembly .....	42-43
Control Assembly .....	44-45
Crankcase Cover Assembly .....	46-47
Crankshaft/Balancer Assembly .....	48-49
Cylinder Barrel Assembly .....	50-51
Fan Cover Assembly .....	52-53
Fly Wheel and Ignition Coil Assembly .....	54-55
Fuel Tank Assembly .....	56-57
Oil Case Assembly .....	58-59
Piston and Connecting Rod Assembly .....	60-61
Recoil Starter Assembly .....	62-63
Tools (Spark Plug) .....	64-65
Labels Assembly .....	66-67
Terms and Conditions of Sale .....	64

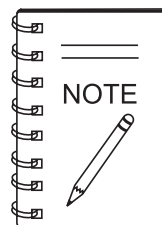

***Specification and part number are  
subject to change without notice.***

# BP-25H GASOLINE VIBRATOR — SPECIFICATIONS (ENGINE)

**Table 1. Specifications (Engine)**

<b>Engine</b>	<b>Model</b>	<b>HONDA GXH50QXA</b>
	Type	4 stroke, Single Cylinder, OHV, Gasoline Engine
	Bore X Stroke	1.65 in. x 1.42 in. (41.8 mm x 36 mm)
	Displacement	49 cm <sup>3</sup> (3.0 cu-in)
	Max Output	2.5 H.P./7,000 R.P.M.
	Fuel Tank Capacity	Approx. 0.32 U.S. gallons (1.2 liters)
	Fuel	Unleaded Gasoline Octane Rating of 86 or Higher
	Lube Oil Capacity	0.26 qts (.25 liters)
	Spark Plug Type	NKG: CR5HSB DENSO: U16FSR-UB
	Spark Plug Gap	0.024 ~ 0.028 in. (0.60 ~ 0.70 mm)
	Speed Control Method	Centrifugal Fly-weight Type
	Starting Method	Recoil Start
<b>Dimension (L x W x H)</b>	8.9 x 10.8 x 13.9 in. (225 x 274 x 353 mm)	
<b>Dry Net Weight</b>	12.1 lbs (5.5 Kg.)	

# BP-25H GASOLINE VIBRATOR — DIMENSIONS

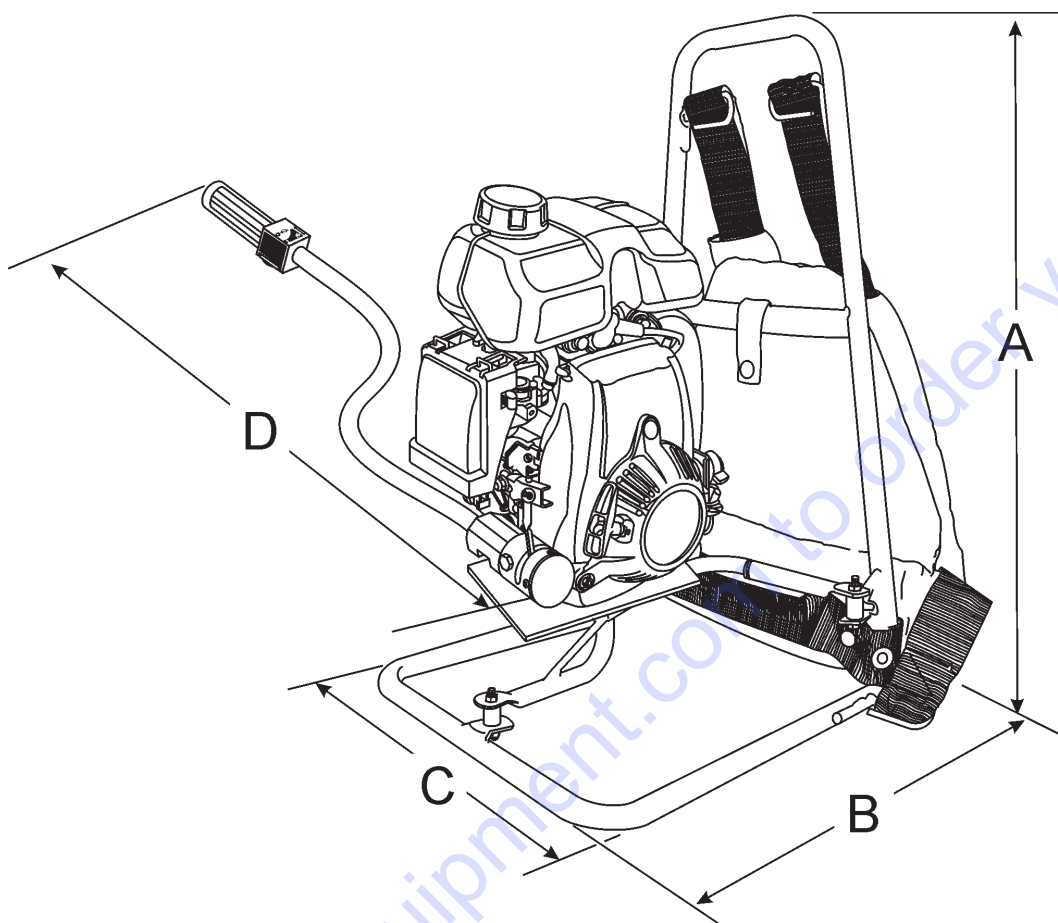

Figure 1. Dimensions (Frame)

TABLE 2. Dimensions (Frame)

Reference Letter	Dimension ft. (mm.)
A	23.0 in. (584 mm.)
B	13.75 in. (349 mm.)
C	13.0 in. (330 mm.)
D	21.0 in. (533 mm.)

# BP-25H GASOLINE VIBRATOR — SAFETY MESSAGE ALERT SYMBOLS

## FOR YOUR SAFETY AND THE SAFETY OF OTHERS!

Safety precautions should be followed at all times when operating this equipment. Failure to read and understand the Safety Messages and Operating Instructions could result in injury to yourself and others.

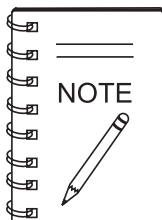

This Owner's Manual has been developed to provide complete instructions for the safe and efficient operation of the Multiquip **Model BP-25H Gasoline Backpack Vibrator**. Refer to the engine manufacturer's instructions for data relative to its safe operation.

**Before using this vibrator, ensure that the operating individual has read and understood all instructions in this manual.**

## SAFETY MESSAGE ALERT SYMBOLS

The three (3) Safety Messages shown below will inform you about potential hazards that could injure you or others. The Safety Messages specifically address the level of exposure to the operator, and are preceded by one of three words: **DANGER**, **WARNING**, or **CAUTION**.

### **DANGER**

You **WILL** be **KILLED** or **SERIOUSLY** injured if you do not follow directions.

### **WARNING**

You **COULD** be **KILLED** or **SERIOUSLY** injured if you do not follow directions.

### **CAUTION**

You **CAN** be injured if you do not follow directions

## HAZARD SYMBOLS

Potential hazards associated with the operation of this equipment will be referenced with "**Hazard Symbols**" which appear throughout this manual, and will be referenced in conjunction with Safety "**Message Alert Symbols**".

### **WARNING - LETHAL EXHAUST GASES**



Gasoline engine exhaust gases contain poisonous carbon monoxide. This gas is colorless and odorless, and can cause **DEATH** if inhaled. **NEVER** operate this

equipment in a confined area or enclosed structure that does not provide ample free flow air.

### **WARNING - EXPLOSIVE FUEL**



**Gasoline** is extremely flammable, and its vapors can cause an explosion if ignited. **DO NOT** start the engine near spilled fuel or combustible fluids. **DO NOT** fill the fuel tank while the engine is running or hot.

**DO NOT** overfill tank, since spilled fuel could ignite if it comes into contact with hot engine parts or sparks from the ignition system. Store fuel in approved containers, in well-ventilated areas and away from sparks and flames. **NEVER** use fuel as a cleaning agent.

### **WARNING - BURN HAZARDS**



Engine components can generate extreme heat. To prevent burns, **DO NOT** touch these areas while the engine is running or immediately after operations. **NEVER** operate the engine with heat shields or heat guards removed.



# BP-25H GASOLINE VIBRATOR — SAFETY MESSAGE ALERT SYMBOLS

## WARNING - ROTATING PARTS



**NEVER** operate equipment with covers, or guards removed. Keep **fingers, hands, hair** and clothing away from all moving parts to prevent injury.

## CAUTION - RESPIRATORY HAZARDS



**ALWAYS** wear approved **respiratory** protection.

## CAUTION - ACCIDENTAL STARTING



**ALWAYS** place the engine **ON/OFF** switch in the **OFF** position when the vibrator is not in use.

## CAUTION - SIGHT AND HEARING HAZARDS

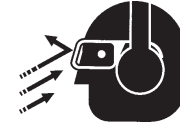

**ALWAYS** wear approved **eye** and **hearing** protection.

## CAUTION - OVER-SPEED CONDITIONS



**NEVER** tamper with the factory settings of the engine governor or settings. Personal injury and damage to the engine or equipment can result if operating in speed ranges above maximum allowable.

## CAUTION - EQUIPMENT DAMAGE MESSAGES

Other important messages are provided throughout this manual to help prevent damage to your vibrator, other property, or the surrounding environment.



This vibrator, other property, or the surrounding environment could be damaged if you do not follow instructions.

# BP-25H GASOLINE VIBRATOR — RULES FOR SAFE OPERATION

## DANGER - READ THIS MANUAL!

Failure to follow instructions in this manual may lead to **serious injury** or even **DEATH!** This equipment is to be operated by trained and qualified personnel only! This equipment is for industrial use only.

The following safety guidelines should always be used when operating the **vibrator**.

### GENERAL SAFETY

- **DO NOT** operate or service this equipment before reading this entire manual.



- This equipment should not be operated by persons under 18 years of age.

- **NEVER** operate this equipment when not feeling well due to fatigue, illness or taking medicine.



- **NEVER** operate this equipment under the influence of drugs or alcohol.



- Whenever necessary, replace nameplate, operation and safety decals when they become difficult read.

- **ALWAYS** check the machine for loosened threads or bolts before starting.

- Dress properly. Wear appropriate clothing and protective safety equipment. Wear clothing that will not likely become caught in the equipment or snag on the forms. Eye, hand, hearing, and foot safety equipment is required.



- **NEVER** touch the hot exhaust manifold, muffler or cylinder. Allow these parts to cool before servicing engine.

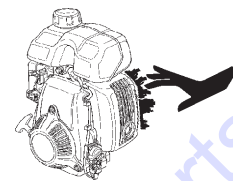

- **High Temperatures** – Allow the engine to cool before adding fuel or performing service and maintenance functions. Contact with **hot!** components can cause serious burns.

- The engine of this vibrator requires an adequate free flow of cooling air. **NEVER!** operate the vibrator in any enclosed or narrow area where free flow of the air is restricted. If the air flow is restricted it will cause serious damage to the vibrator or engine and may cause injury to people and property. Remember the engine gives off **DEADLY** gases.

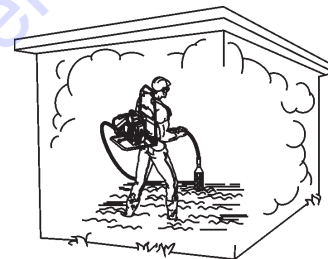

- **ALWAYS** refuel in a well-ventilated area, away from sparks and open flames.

- **ALWAYS** use extreme caution when working with **flammable** liquids. When refueling, **stop the engine** and allow it to cool. **DO NOT** smoke around or near the machine. Fire or explosion could result from fuel vapors, or if fuel is spilled on a hot engine.

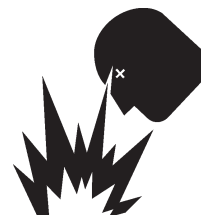

- **NEVER** operate the equipment in an explosive atmosphere or near combustible materials. An explosion or fire could result causing severe **bodily harm or even death**.

- Topping-off to filler port is dangerous, as it tends to spill fuel.

- Refer to the **Engine Owner's Manual** for engine technical questions or information.

- **NEVER** use accessories or attachments, which are not recommended by Multiquip for this equipment. Damage to the equipment and/or injury to user may result.

- Manufacturers do not assume responsibility for any accident due to equipment modifications.

# BP-25H GASOLINE VIBRATOR — RULES FOR SAFE OPERATION

- **NEVER** run engine without air cleaner. Severe engine damage may occur.
- **ALWAYS** read, understand, and follow procedures in Operator's Manual before attempting to operate equipment.
- **ALWAYS** be sure the operator is familiar with proper safety precautions and operating techniques before using vibrator.
- **ALWAYS** store equipment properly when it is not being used. Equipment should be stored in a clean, dry location out of the reach of children.
- **NEVER** leave the vibrator unattended, turn off engine when unattended.
- Unauthorized equipment modifications will void all warranties.
- **NEVER** use vibrator near flammable or low flash point fluids. These fluids could ignite or explode.
- **ALWAYS** become familiar with the components of the vibrator before operating.
- **ALWAYS** replace nameplate, operation and safety decals when they become difficult to read.
- **NEVER** operate vibrator around corrosive chemicals or water containing toxic substances. These fluids could create serious health and environmental hazards. Contact local authorities for assistance.
- **NEVER** use accessories or attachments which are not recommended by the manufacturer for this equipment. Damage to the equipment and/or injury to user may result.
- Manufacturer does not assume responsibility for any accident due to equipment modifications. Unauthorized equipment modification will void all warranties. Any modification which could lead to a change in the original characteristics of the machine should be made only by the manufacturer who shall confirm that the machine is in conformity with appropriate safety regulations.
- **ALWAYS** observe all applicable compulsory regulations relevant to environmental protection, especially, fuel storage, the handling of hazardous substances, and the wearing of protective clothing and equipment. Instruct the user as necessary, or, as the user, request this information and training.

## Maintenance Safety:

- **NEVER** lubricate components or attempt service on a running machine.
- **ALWAYS** allow the vibrator a proper amount time to cool before servicing.
- Keep the machinery in proper running condition.
- Fix damage to the machine immediately and always replace broken parts.
- Dispose of hazardous waste properly. Examples of potentially hazardous waste are used motor oil, fuel and fuel filters.
- **DO NOT** use food or plastic containers to dispose of hazardous waste.
- **DO NOT** pour waste, oil or fuel directly onto the ground, down a drain or into any water source.

## TRANSPORTING

- **ALWAYS** shutdown engine before transporting.
- Tighten fuel tank cap securely and close fuel cock to prevent fuel from spilling.
- **ALWAYS** use proper lifting techniques when using or moving the vibrator motor (backpack), flexible shaft, or vibrator head assembly.

## EMERGENCIES

- **ALWAYS** know the location of the nearest **fire extinguisher**.
- **ALWAYS** know the location of the nearest **first aid kit**.
- In emergencies **always** know the location of the nearest phone or **keep a phone on the job site**. Also know the phone numbers of the nearest **ambulance, doctor and fire department**. This information will be invaluable in case of an emergency.



- **NEVER** disconnect any "**emergency or safety devices**". These devices are intended for operator safety. Disconnection of these devices can cause severe injury, bodily harm or even death! Disconnection of any of these devices will void all warranties.

# BP-25H GASOLINE VIBRATOR — GENERAL INFORMATION

## General Information

The BP-25H utilizes a 2.5 HP Honda GXH50 4-stroke, overhead valve, single cylinder, gasoline engine. The vibrator comes standard with a quick-disconnect coupling for easy removal of the flexible shaft.

In addition, the frame is mounted on rubber isolators (3) to help reduce engine vibration.

When operating the BP-25H Vibrator, always wear rubber insulated gloves and boots. Safety glasses and ear protection are also recommended.

## Tips

- Keep the bending radius of the flexible hose to a minimum during use.
- Avoid starting the unit with the vibrator head immersed in the concrete mix. After the engine has started, immerse the vibrator head into concrete mix.
- Excessive wear to the vibrating head can result from misuse. **DO NOT** allow the head to vibrate against already hardened concrete or steel used in reinforcement.
- **NEVER** drop or knock the vibrator head against any hard objects. This will prevent damage to the eccentric or bearings contain within the head.
- **ALWAYS** rinse or wipe off any wet concrete before it dries or hardens on any part of the unit (engine, shaft, or head).

Before operating this gasoline powered vibrator, the operator must **read** and **understand** the contents of the operation manual. Failure to read this manual could result in severe bodily harm and damage to the equipment.



## Theory of Backpack Vibrator

The vibrator is designed for the **consolidation** of concrete by removal of air pockets and voids.

The purpose of this vibrator is to set the particles in the fresh concrete in motion, thereby reducing the friction and giving the mixture a mobile quality so that gravity and the displacement of entrapped air allows the concrete to settle easily into place.

By consolidating the concrete quickly, "stiffer" or "drier" mixes can be poured than would otherwise be possible.

Vibration also make the concrete more watertight, increasing resistance to weathering, and creating a better bond between concrete and reinforcement.

Because vibration causes much of the entrapped air in the concrete to rise to the surface, honeycombing is prevented. Also, vibration eliminates most of the air pockets between the concrete and the vertical forms.

## BP-25H GASOLINE VIBRATOR — VIBRATOR COMPONENTS

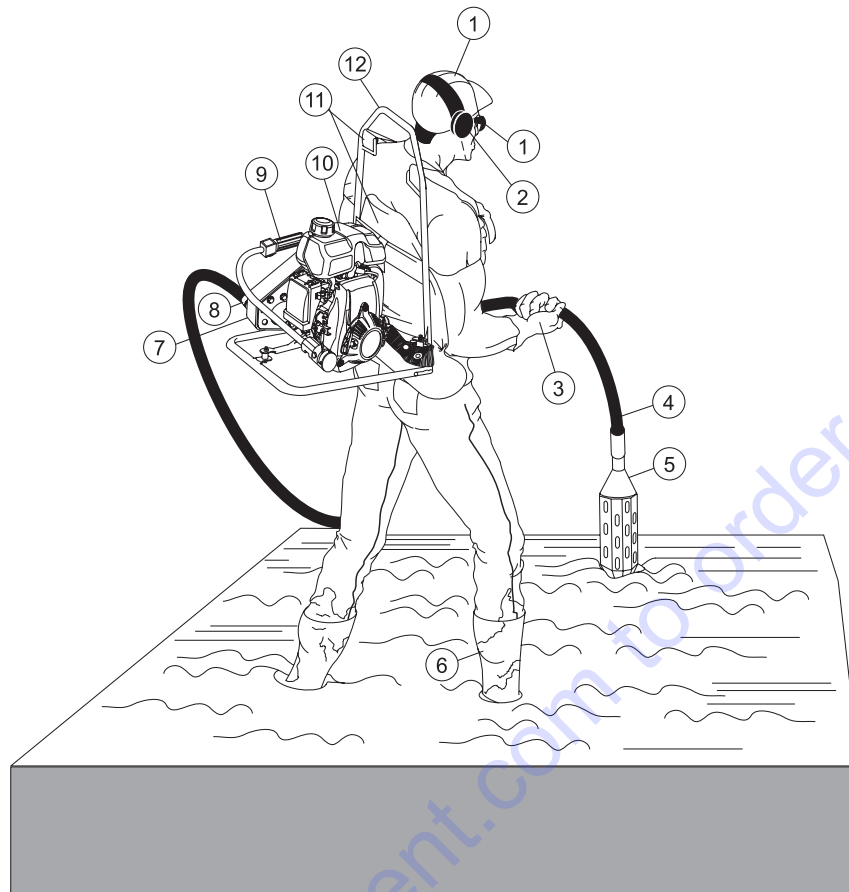

Figure 3. BP-25H Gasoline Vibrator Application

1. **Hard Hat** – Always wear a hard hat for head protection.
2. **Safety Glasses** – Always wear safety glasses to protect eyes from foreign matter and debris.
3. **Rubber Gloves** – Always wear rubber gloves to protect hands from abrasive materials.
4. **Flexible Shaft** – The BP-25H can accommodate various shaft lengths. See Tables 4 and 5 for shaft length dimensions.
5. **Vibrating Head** – The BP-25H can accommodate various vibrating heads. See Table 6 for various head types. Typical applications include large retaining walls, bridge decks, and columns.
6. **Rubber Boots** – Always wear rubber boots to protect feet from abrasive materials.
7. **Belt Guard** – Prevents access to the pulleys or V-belt while vibrator is running. **DO NOT** operate the vibrator with this cover removed.
8. **Quick Disconnect Fitting** – Allows for the quick and easy removal of the flexible shaft from the vibrator.
9. **Throttle Grip** – Turn clockwise (rabbit) to increase engine speed, turn counterclockwise (turtle) to decrease engine speed.
10. **Engine** – The BP-25H utilizes a 2.5 HP Honda GXH50, 4-stroke, overhead valve, single cylinder, gasoline engine.
11. **Backpack Harness/Pad** – The BP-25H is equipped with an adjustable harness. Adjust the harness to a comfortable fit so that it will not slip or fall. In addition a back pad has been added for operator comfort.
12. **Frame** – Made of a lightweight metal alloy, this frame features an engine support platform that can be rotated 360 degrees. In addition, the frame has three rubber shock mounts installed to help reduce engine vibration.

# BP-25H GASOLINE VIBRATOR — ENGINE COMPONENTS

## INITIAL SERVICING

The engine (Figure 4) must be checked for proper lubrication and filled with fuel prior to operation. Refer to the manufacturer's engine manual for instructions.

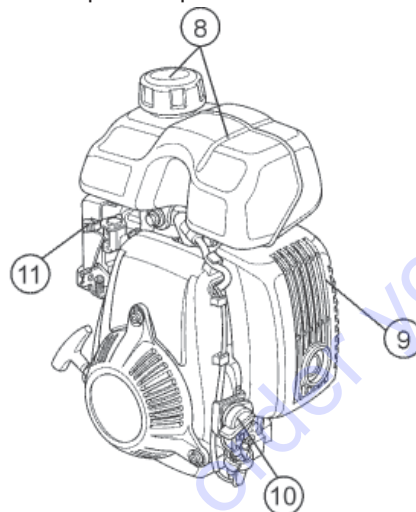
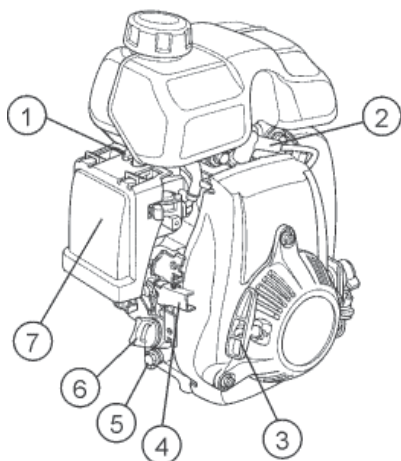

Figure 4. Honda GXH50 Engine Components

1. **Choke Lever** – Used in the starting of a cold engine, or in cold weather conditions. The choke enriches the fuel mixture.
2. **Spark Plug** – Provides spark to the ignition system. Clean spark plug once a week.
3. **Recoil Starter (pull rope)** – Manual-starting method. Pull the starter grip until resistance is felt, then pull briskly and smoothly.
4. **Throttle Lever** – Used to adjust engine RPM speed (lever advanced forward **SLOW**, lever back toward operator **FAST**).
5. **Oil Drain Plug** – Remove this plug to remove oil from the engine's crankcase.
6. **Dipstick/Oil Filler Cap** – Remove this cap to determine if the engine oil is low. Add oil through this filler port as recommended in Table 3.
7. **Air Filter** – Prevents dirt and other debris from entering the fuel system. Press the latch tabs on the top of the air cleaner cover, and remove cover to gain access to filter element.
8. **Fuel Tank/Fuel Filler Cap** – Fuel tank holds 0.32 gallons (1.2 liters) of unleaded gasoline. Remove fuel filler cap to add unleaded gasoline to the fuel tank. Make sure cap is tightened securely. **DO NOT** over fill.
9. **Muffler** – Used to reduce noise and emissions.
10. **Engine ON/OFF Switch** – **ON** position permits engine starting, **OFF** position stops engine operation.
11. **Fuel Valve Lever** – **OPEN** to let fuel flow, **CLOSE** to stop the flow of fuel.

### ! DANGER - EXPLOSIVE FUEL HAZARD

Adding fuel to the tank should be done only when the engine is stopped and has had an opportunity to cool down. In the event of a fuel spill **DO NOT** attempt to start the engine until the fuel residue has been completely wiped up, and the area surrounding the engine is dry.



### ! DANGER - BURN HAZARD

Engine components can generate extreme heat. To prevent burns, **DO NOT** touch these areas while the engine is running or immediately after operating. **NEVER** operate the engine with the muffler removed.

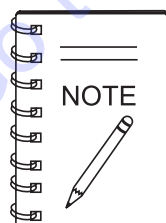
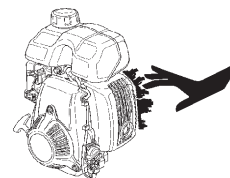

*Operating the engine without an air filter, with a damaged air filter, or a filter in need of replacement, will allow dirt to enter the engine causing rapid engine wear.*

# BP-25H GASOLINE VIBRATOR — INSPECTION (ENGINE)

## Before Starting

Before starting and operating the BP-25H Gasoline Vibrator, perform the following:

- Read safety instructions at the beginning of the manual.
- Clean the engine, removing dirt and dust, particularly the engine cooling air inlet, carburetor and air cleaner.
- Check the air filter for dirt and dust. If air filter is dirty, replace air filter with a new one as required.
- Check carburetor for external dirt and dust. Clean with dry compressed air.
- Check fastening nuts and bolts for tightness.
- Check the engine oil level.
- Check the fuel level.
- Check the tension and condition of the V-belt.

## Engine Oil Check

1. To check the engine oil level, place the backpack frame on secure level ground with the engine stopped.
2. Remove the filler dipstick from the engine oil filler hole (Figure 5) and wipe clean.

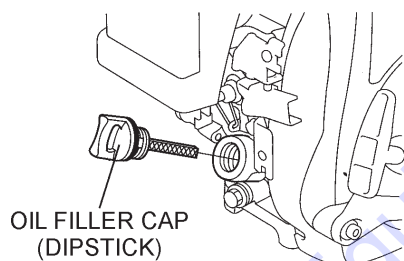

Figure 5. Engine Oil Dipstick (Removal)

3. Insert and remove the dipstick without screwing it into the filler neck. Check the oil level shown on the dipstick.
4. If the oil level is low (Figure 6), fill to the edge of the oil filler hole with the recommended oil type (Table 3). Maximum oil capacity is 0.26 quarts (0.25 liters).

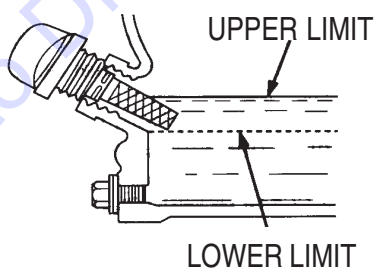

Figure 6. Engine Oil Dipstick (Oil Level)

Table 3. Oil Type

Season	Temperature	Oil Type
Summer	25°C or Higher	SAE 10W-30
Spring/Fall	25°C~10°C	SAE 10W-30/20
Winter	0°C or Lower	SAE 10W-10

## Fuel Check

1. Remove the gasoline cap located on top of fuel tank.
2. Visually inspect to see if fuel level is low. If fuel is low, replenish with unleaded fuel.
3. When refueling, be sure to use a strainer for filtration. **DO NOT** top-off fuel. Wipe up any spilled fuel.



## DANGER - EXPLOSIVE FUEL HAZARD

Gasoline is extremely flammable, and its vapors can cause an explosion if ignited. **DO NOT** start the engine near spilled fuel or combustible fluids.



**DO NOT** fill the fuel tank while the engine is running or hot. **DO NOT** overfill tank, since spilled fuel could ignite if it comes into contact with hot engine parts or sparks from the ignition system. Store fuel in approved containers, in well-ventilated areas and away from sparks and flames.

When refueling vibrator, **ALWAYS** remove backpack from operator.

## V-Belt Check

A worn or damaged V-belt can adversely affect the performance of the vibrator.

1. Unscrew the bolts (7) securing the belt guard to the unit.
2. Inspect the V-belt for defects or signs of wear.
3. If the V-belt is defective or worn, replace the V-belt as outlined in the maintenance section of this manual.
4. A properly tensioned V-belt (Figure 23) should deflect approximately 5 to 10 mm when 5-10 pounds of force is applied centrally between the pulleys.

# BP-25H GASOLINE VIBRATOR — HEAD AND SHAFT SELECTIONS

## Flexible Shaft and Vibrator Head Selections

Use Tables 4, 5, and 6 when selecting a flexible shaft or vibrator head for your unit. Longer shaft lengths (382V Series only) can be obtained with the use of a shaft coupler (P/N 3883-501). The 314V Series flexible shafts cannot be extended.



### WARNING - EQUIPMENT HAZARD

Never use vibrator heads that are **not** recommended by the manufacturer as they may create a hazardous condition when using the vibrator.

**Table 4. 314V Series Flexible Shafts**

MODEL	LENGTH ft. (m)	WEIGHT lb. (kg)
314V2	2 (0.6)	3 (1.3)
314V5	5 (1.5)	5 (2.4)
314V7	7 (2.1)	6 (2.9)
314V10	10 (3)	9 (4.0)
314V12	12 (3.7)	10 (4.8)
314V14	14 (4.3)	11 (5.1)
314V18	18 (5.5)	15 (6.9)
314V21	21 (6.4)	18 (8.3)

**Table 5. 382V Series Flexible Shafts**

MODEL	LENGTH ft. (m)	WEIGHT lb. (kg)
382V2	2 (0.6)	4 (1.8)
382V5	5 (1.5)	8 (3.8)
382V7	7 (2.1)	11 (5)
382V10	10 (3)	16 (7.2)
382V12	12 (3.7)	18 (8)
382V14	14 (4.3)	20 (9)
382V18	18 (5.5)	24 (10.8)
382V21	21 (6.4)	28 (12.7)

**Table 6. Vibrator Head Selection Chart**

MODEL	HEAD TYPE	DIAMETER in. (mm)	LENGTH in. (cm)	WEIGHT lb. (kg)	REQUIRED SHAFT
900HD	Steel	7/8 (22)	14 1/2 (37)	2.1 (1)	314V
1000HD	Steel	1 1/16 (27)	13 7/8 (35)	2.8 (1.3)	314V
1300HD	Steel	1 3/8 (35)	15 1/2 (39)	5.1 (2.3)	314V
1400HD	Steel	1 3/8 (35)	15 1/4 (39)	5.2 (2.4)	382V
1700HD	Steel	1 11/16 (43)	15 (38)	6.4 (2.9)	382V
2100HD	Steel	2 1/8 (54)	13 1/4 (34)	9.4 (4.3)	382V
2600HD	Steel	2 5/8 (67)	13 1/4 (34)	13.4 (6.1)	382V
RHV188	Steel/Rubber	1 7/8 (48)	15 3/4 (40)	5 (2.3)	382V
RHV250	Steel/Rubber	2 1/2 (63)	15 3/4 (40)	7 (3.2)	382V
RHV275S	Steel/Rubber	2 3/4 (69)	8 (20)	4.5 (2.1)	382V



# BP-25H GASOLINE VIBRATOR — HEAD AND SHAFT CONNECTIONS

Follow the instructions below when connecting the flexible shaft, vibrator head, and vibrator, before using the BP-25H.

## GREASING INSTRUCTIONS

1. Before installing a new flexshaft assembly, pull out the core and lightly grease before first use. Place a handful of clean grease (use Shell Durina EP2 high- temperature, high-pressure grease or equivalent) in a shop cloth and slide the clean core through grease as you feed it back into the shaft housing.
2. After every job, or every 50 hours, the shaft should be disassembled, cleaned, inspected, lubricated, and reassembled.

## 314V Series

### Connecting the Flexible Shaft and Vibrating Head

Perform the following instructions to attach the flexible shaft to the vibrator, reference Figure 7:

- 1 Remove the female “Quick Disconnect” (Q.D.) coupler and spindle shaft (female) from the parts bag. Note: The QD coupler and spindle shaft for the 314V Series are sold separately.
- 2 Screw the spindle shaft onto the male end of the flexible shaft. Tighten securely.
- 3 Screw the QD coupling onto the male end of the flexible shaft. Tighten securely.
- 4 Pull up on the Q.D. locking knob and insert the Q.D. coupler into the eccentric end bell assembly.
- 5 Attach the vibrating head to the other end of the flexible shaft. It is recommended the use of a small amount of pipe thread sealant (Loctite No.271) on the flexible shaft casing coupling threads to prevent water from entering the vibrator head.

### Applying Loctite

When applying loctite to the flexible shaft casing threads, perform the following:

1. Clean the mating connector or coupler threads with Loctite Primer “T”.
2. Allow to dry several minutes before applying a ring of Loctite No.271 to the middle of the flexible shaft casing threads.
3. Screw the head tightly to the flexible shaft casing and wait for 1 hour before using. The threads are left hand, turn counterclockwise to tighten. An equivalent brand of anaerobic sealant may be used.

## 382V Series

### Connecting the Flexible Shaft and Vibrating Head

Perform the following instructions to attach the flexible shaft to the vibrator, reference Figure 7:

- 1 Remove the male “Quick Disconnect” (Q.D.) coupler and spindle shaft (male) from the parts bag. Note: the QD coupler and spindle shaft for the 382V Series are included with the motor.
- 2 Screw the spindle shaft into the female end of the flexible shaft. Tighten securely.
- 3 Screw the QD coupling into the female end of the flexible shaft. Tighten securely.
- 4 Pull up on the Q.D. locking knob and insert the Q.D. coupler into the eccentric end bell assembly.
- 5 Attach the vibrating head to the other end of the flexible shaft. It is recommended the use of a small amount of pipe thread sealant (Loctite No.271) on the flexible shaft casing coupling threads to prevent water from entering the vibrator head.

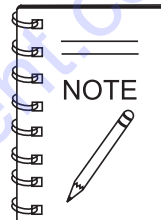

When **rubber** vibrator heads are used, it is advised to place a protective sleeve over the flexible shaft casing coupler. This will protect epoxy coated rebar from being damaged. See proceeding pages in this manual for the “**Protective Sleeve**” installation instructions.

### Disassembly Instructions (use protective leather gloves)

1. Remove motor from shaft.
2. Pull core from shaft housing. The head does not need to be removed unless it also requires servicing.
3. As the core is removed, slide it through a clean shop cloth to wipe off old grease. Keep it clean and off the ground or floor.
4. After inspecting the core for obvious damage, place a handful of clean grease (use Shell Durina EP2 high- temperature, high-pressure grease or equivalent) in a shop cloth and slide the clean core through grease as you feed it back into the shaft housing. This will lightly coat the core. Do not overgrease. As the square end of the core approaches the head, turn slightly to engage drive adapter inside the head while continuing to push it towards the head.
5. Install motor to shaft assembly and securely tighten nut.
6. Test run the motor and check head vibration. Do not run longer than one or two minutes when in the air (not in concrete mix).

# BP-25H GASOLINE VIBRATOR — HEAD AND SHAFT CONNECTIONS

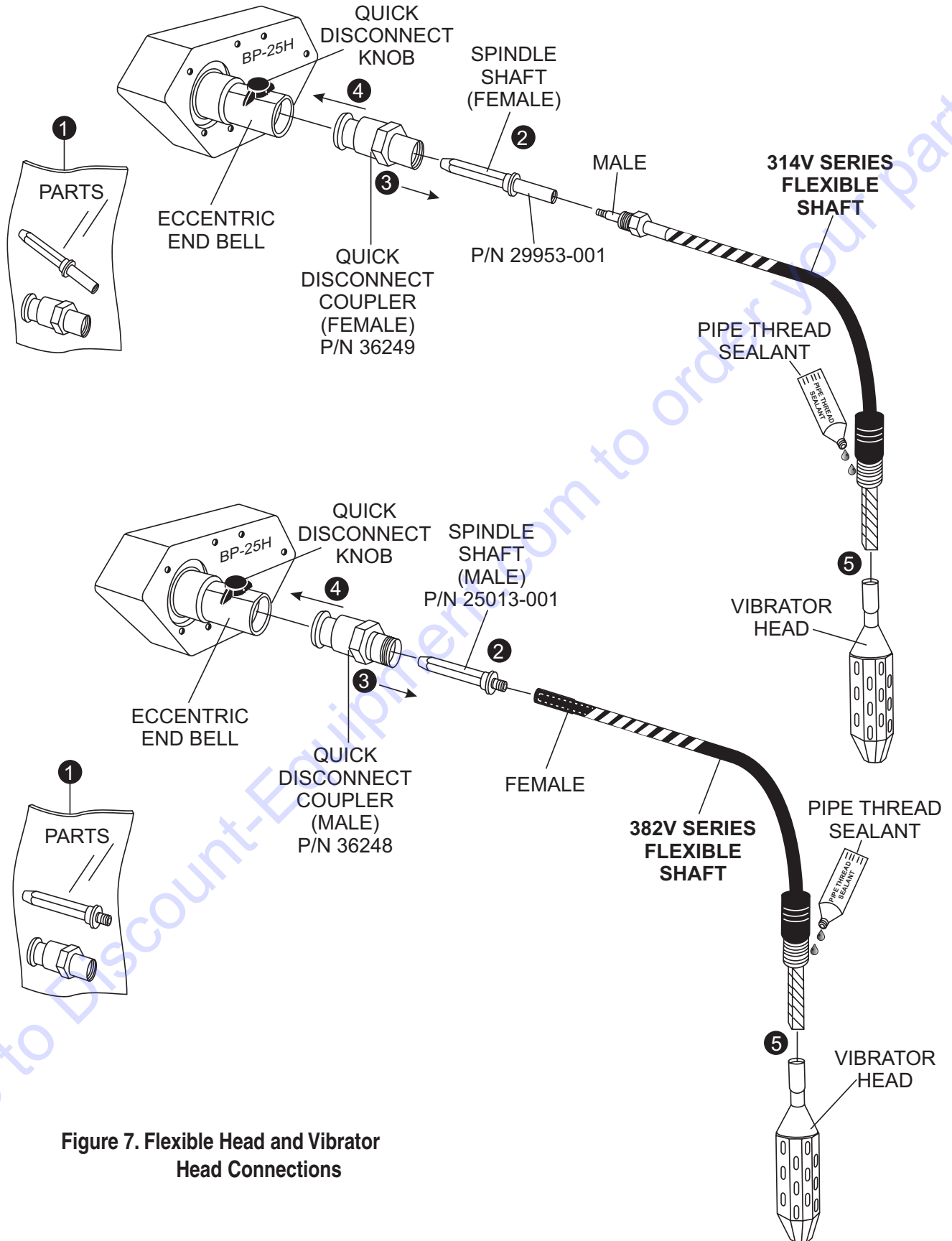

Figure 7. Flexible Head and Vibrator Head Connections

# BP-25H GASOLINE VIBRATOR — PROTECTIVE SLEEVE INSTALLATION

## Casing Coupling Protective Sleeve

When **rubber** vibrator heads are used, it is advisable to place a **protective sleeve** over the flexible shaft casing coupler. This will protect epoxy coated rebar from being damaged. Please follow the instructions listed below to install the protective sleeve. Reference Figure 8 when performing the installation of the protective sleeve.

- 1 Slide the casing cover protective sleeve onto and the flexible shaft (vibrator end).
- 2 Using an open end wrench and locking type pliers, attach vibrator head to flexible shaft. It is recommended to apply a small amount of pipe thread sealant on the casing coupler threads to prevent water from entering the vibrator head.
- 3 Apply a uniform 3/8" bead of adhesive about 4-inches long over the casing coupling.
- 4 Push casing coupling protective sleeve over flexible shaft coupling, rotating sleeve as you push, until end of sleeve enters recess on vibrator head.
- 5 Make sure to place a bead of adhesive at the opposite end of the sleeve to prevent wet concrete from entering the opening.

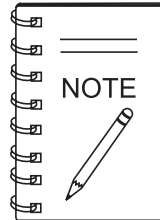

It will take approximately **one hour** for the sealant to set (cure) so that the protective sleeve will stay in place during operation.

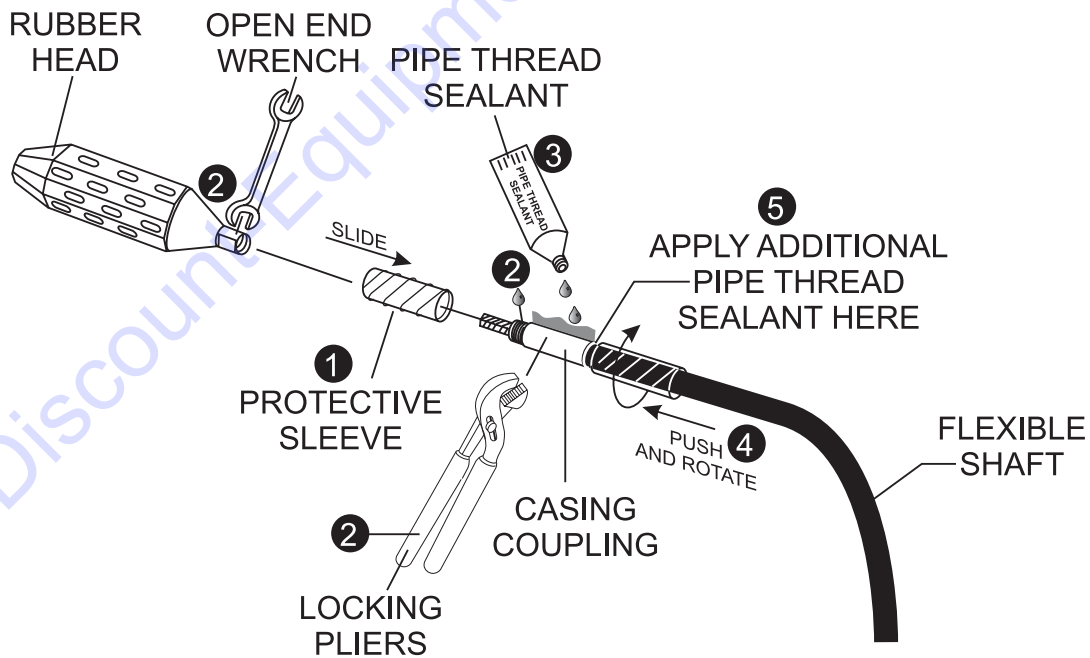

Figure 8. Casing Coupling Protective Sleeve Installation

# BP-25H GASOLINE VIBRATOR — INITIAL START-UP (ENGINE)

This section is intended to assist the operator with the *initial start-up* of the BP-25H vibrator. It is extremely important that this section be read carefully before attempting to use the vibrator in the field.

## Starting the Engine

1. Place the engine **fuel valve lever** (Figure 9) to the "ON" position.

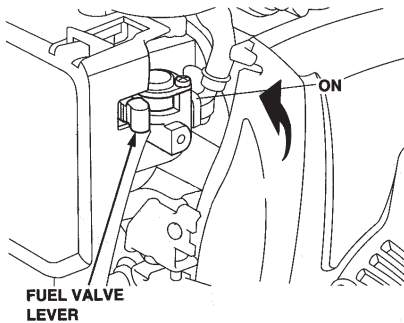

Figure 9. Engine Fuel Valve Lever (ON Position)

2. Place the **choke lever** (Figure 10) in the "CLOSED" position if starting a **cold** engine.

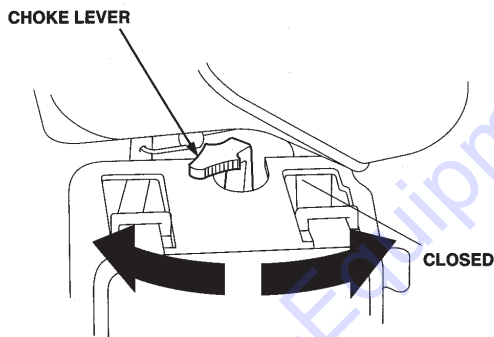

Figure 10. Engine Choke Lever (Closed)

3. Place the **choke lever** (Figure 11) in the "OPEN" position if starting a **warm engine** or the **temperature is warm**.

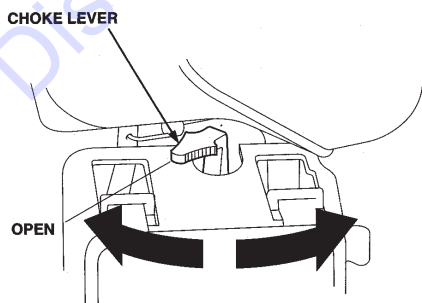

Figure 11. Engine Choke Lever (Open)

4. Place the **Ignition ON/OFF switch** (Figure 12) in the "ON" position.

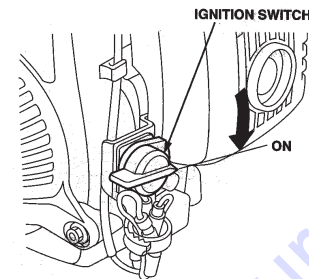

Figure 12. Ignition ON/OFF Switch (ON Position)

6. Turn the **throttle grip** CCW to the "TURTLE" position (Figure 13) to start the engine in the idle mode.

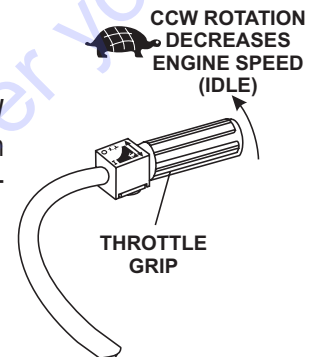

Figure 13. Throttle Grip (Idle/Turtle Position)

7. Grasp the starter grip (Figure 14) and slowly pull it out. The resistance becomes the hardest at a certain position, corresponding to the compression point. Pull the starter grip briskly and smoothly for starting.

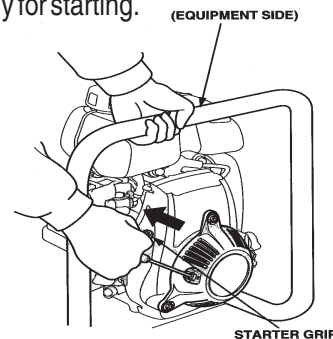

Figure 14. Starter Grip

8. If the engine has started, slowly return the choke lever (Figure 15) to the "OPEN" position. If the engine has not started repeat steps 1 through 6.

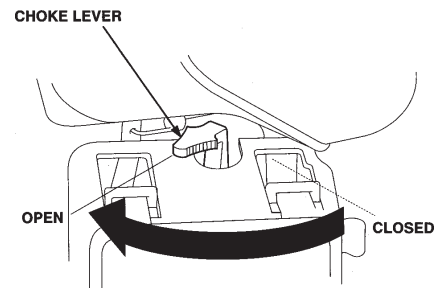

Figure 15. Choke Lever (Open)

# BP-25H GASOLINE VIBRATOR — OPERATION

## ⚠ CAUTION - READ MANUAL

**DO NOT** attempt to operate the vibrator until the Safety, General Information and Inspection sections of this manual have been **read thoroughly and understood**.



## Backpack Placement

1. With the engine running at idle speed, place the backpack on an elevated flat level surface (workbench or tailgate of a truck). This will enable the operator to place the unit on his back more easily.
2. The backpack unit attaches very much like a hiker's knapsack. Place your arms through the spaces between the shoulder straps and the frame.
3. Next, bring the abdominal straps to the front and adjust the straps accordingly. There are two sets of velcro straps, one set for the chest and another for the waist area.

## Operation

1. Insert the vibrator head into the concrete.
2. Turn the throttle grip (Figure 16) CW to the **"RABBIT"** (fast) position for normal operation.

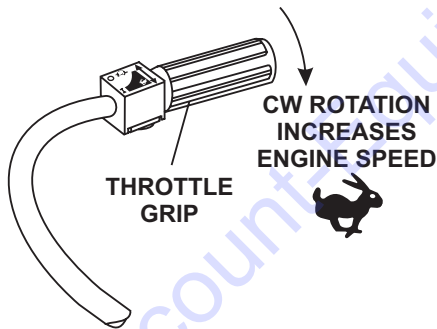

Figure 16. Throttle Grip (Rabbit/Fast)

3. Insert the vibrator head vertically into the concrete and move it in the pattern shown in Figure 17 to maintain a consistent area of influence.

4. Immerse the head for 5 to 10 seconds, (until air stops rising), and then withdraw it slowly to let the concrete fill the void left by the vibrator head.
5. The vibrator head should be completely below the surface when vibrating to keep the head cool.
6. Use the flexible shaft in as straight a position as possible and **DO NOT** bend the flexible shaft sharply at any point. Sharp bends may cause overheating, requiring early replacement of the flexible shaft.

## ⚠ CAUTION - SHAFT OVERLOAD HAZARD

If the shaft begins to helix (buckle) excessively during operation, stop and investigate. This is an indication of an overload condition.

## ⚠ CAUTION - VIBRATOR HEAD OVERHEATING

The vibrator head is cooled by the concrete. Operation of the vibrator head in air longer than 2 minutes will cause overheating of the bearings which result in premature head failure.

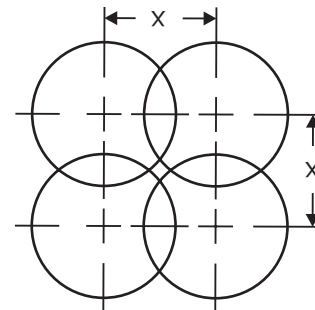
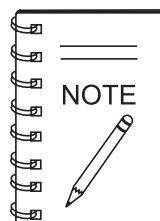

Figure 17. Area of Influence with 50% Radial Overlap



**DO NOT** operate head out of the mix for more than a few minutes to prevent overheating. Wet concrete keeps vibrator head at proper operating temperature.

# BP-25H GASOLINE VIBRATOR — ENGINE SHUTDOWN

## Stopping The Engine

### Normal Shutdown

1. Remove the flexible shaft and vibrator head from the mix.
2. Rotate the throttle grip CCW to the “**TURTLE**” position (Figure 18) and run the engine for three minutes at idle speed.

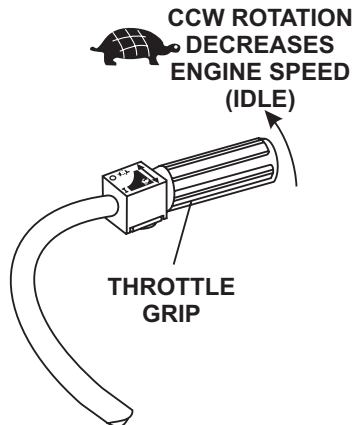

Figure 18. Throttle Lever (Turtle/Idle)

3. Press and hold the engine **KILL** switch (Figure 19) to shutdown the engine. The engine kill switch is located underneath the metal square box on the handle.

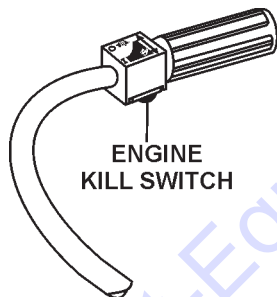

Figure 19. Engine Kill Switch

4. Place the **fuel shut-off lever** (Figure 20) in the **OFF** position.

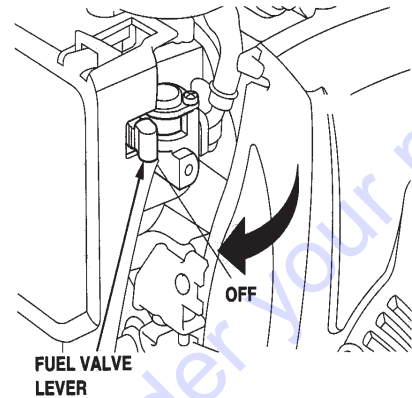

Figure 20. Fuel Valve Lever (OFF)

5. Place the engine **ON/OFF Switch** (Figure 21) in the **OFF** position.

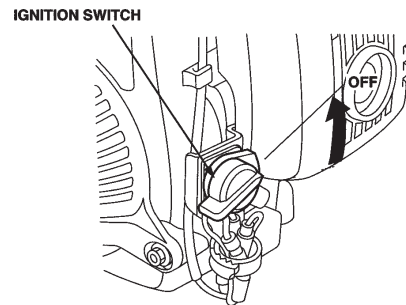

Figure 21. Ignition ON/OFF Switch (OFF Position)

### Emergency Showdown

1. Press and hold the engine **KILL** switch (Figure 19).

# BP-25H GASOLINE VIBRATOR — MAINTENANCE (ENGINE)

## Engine Maintenance

Perform engine maintenance procedures as referenced by Table 7 below:

**Table 7. Engine Maintenance Schedule**

DESCRIPTION (3)	OPERATION	BEFORE	FIRST MONTH OR 10 HRS.	EVERY 3 MONTHS OR 25 HRS.	EVERY 6 MONTHS OR 50 HRS.	EVERY YEAR OR 100 HRS.	EVERY 2 YEARS OR 200 HRS.
Engine Oil	CHECK	X					
	CHANGE		X				
Air Cleaner	CHECK	X					
	CHANGE			X (1)			
All Nuts & Bolts	Re-tighten If Necessary	X					
Spark Plug	CHECK-CLEAN				X		
	REPLACE						X
Cooling Fins	CHECK				X		
Spark Arrester	CLEAN					X	
Fuel Tank	CLEAN					X	
Fuel Filter	CHECK					X	
Idle Speed	CHECK-ADJUST					X (2)	
Valve Clearance	CHECK-ADJUST						X (2)
Fuel lines	CHECK	Every 2 years (replace if necessary) (2)					

(1) Service more frequently when used in **DUSTY** areas.

(2) These items should be serviced by your servic dealer, unless you have the proper tools and are mechanically proficient. Refer to the **HONDA** shop Manual for service procedures

(3) For commercial use, log hours of operation to determine proper maintenance intervals.

(4) Disconnect spark plug before performing maintenance or removing V-belt cover.

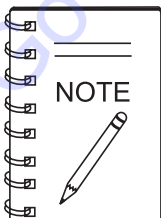

*Reference manufacturer engine manual for specific servicing instructions.*

# BP-25H GASOLINE VIBRATOR — MAINTENANCE (ENGINE)

## Maintenance Instructions

To receive trouble-free service from your MQ BP-25H gasoline vibrator, follow these instructions, as well as the instructions contained in the engine operating manual, flexible shaft operations manual and the vibrator head operations manual.

The flexible shafting requires cleaning and lubrication every 100 hours of operation. See flexible shaft maintenance instructions shipped with shaft.

Vibrator heads should be inspected and relubricated every 100 hours of operation. See vibrator head maintenance instructions shipped with vibrator head.

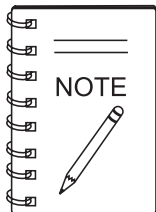

*Heat should be used to break down the loctite while you unthread the head from the shaft. This will prevent possible damage to the threads from the loctite.*

## ! WARNING - STOPPING ENGINE (MAINTENANCE)

Whenever assembling, lubricating, or adjusting any part of the gasoline vibrator make certain to stop the engine, disconnect the spark plug wire and secure it away from the spark plug.

### Daily

- Thoroughly remove dirt and oil from the engine and control area. Clean or replace the air cleaner elements as necessary. Check and retighten all fasteners as necessary. Check the gearbox for oil leaks. Repair or replace as needed.

### Weekly

- Remove the fuel filter cap and clean the inside of the fuel tank.
- Remove or clean the filter at the bottom of the tank.
- Remove and clean the spark plug (Figure 22), then adjust the spark gap to 0.024 ~0.028 inch (0.6~0.7 mm). This unit has electronic ignition, which requires no adjustments.

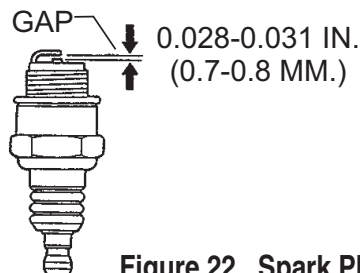

Figure 22. Spark Plug Gap

## Engine Oil

- Drain the engine oil when the oil is **warm** as shown in Figure 23.
- Remove the oil drain bolt and sealing washer and allow the oil to drain into a suitable container.
- Replace engine oil with recommended type oil as listed in Table 3. For engine oil capacity, see Table 2 (engine specifications). **DO NOT** overfill.
- Install drain bolt with sealing washer and tighten securely.

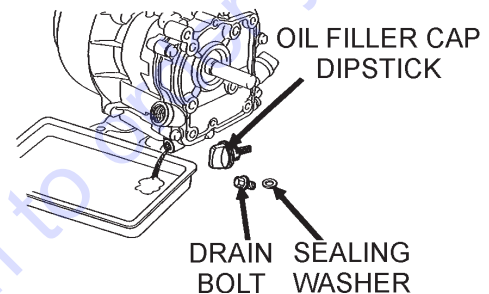
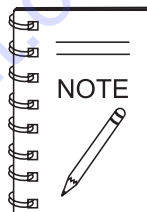

Figure 23. Engine Oil (Draining)



*Dispose of used oil properly. **DO NOT** pour used oil on the ground or down a drain.*

Used oil can generally be taken to your local recycling center or service station for reclamation. Follow all required environmental rules and regulations required in your area concerning the disposal of hazardous waste such as used oil and oil filters.

## Vibrating Head

- Always inspect vibrating head for damage to threads after every assembly. Replace housing and head as necessary.
- Measure vibrations per minute at the head to determine if bearings in head require replacement.

## Flexible Shaft

- Remove, clean grease, the shaft core and bearings every 100 hours. Use **Shell Durina EP2** or equivalent grease. Wipe off old grease completely and apply new grease to shaft evenly.
- DO NOT** allow water, dust or foreign debris to enter the flexible hose while reassembling.



# BP-25H GASOLINE VIBRATOR — MAINTENANCE

## Engine Air Cleaner

1. Press the latch tabs on the top of the air cleaner cover and remove the cover and foam filter element as shown in Figure 24.
2. Clean foam element in warm, soapy water or nonflammable solvent. Rinse and dry thoroughly. Dip the element in clean engine oil and completely squeeze out the excess oil from the element before installing.

**! DANGER - EXPLOSIVE FUEL HAZARD**

**DO NOT** use gasoline as a cleaning solvent to avoid creating the risk of fire or an explosion.

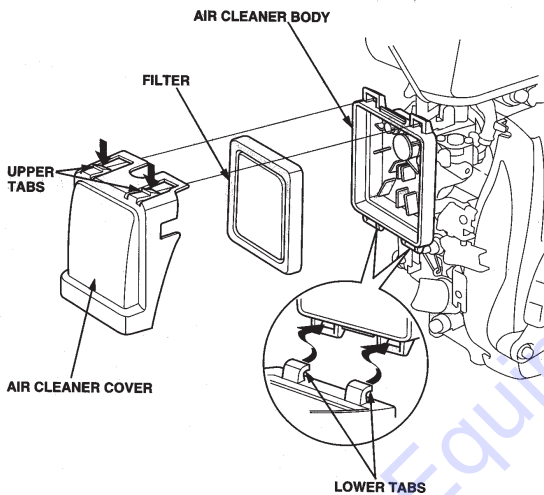



Figure 24. Engine Air Cleaner

3. Reinstall the filter and air cleaner cover.

## V-Belt Tension

The V-belt (Figure 25) can be adjusted by loosening the bearing block housing screws, and rotating the eccentric end bell housing until the desired tension is achieved. When the V-belt is properly tensioned, it should deflect approximately 5 to 10 mm when 5-10 pounds of force is applied centrally between the pulleys. Lock the countershaft in place with the locking screw and wing nut.

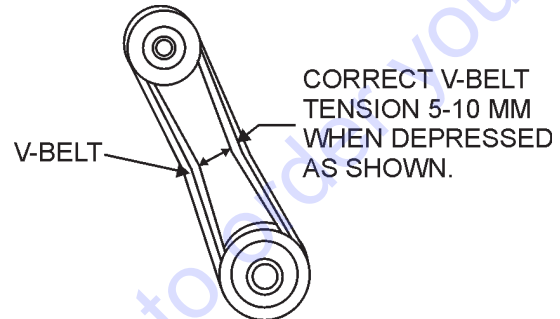

Figure 25. V-Belt Tension

## Quick Disconnect Lock

A small amount of any lightweight oil should be used on the locking mechanism (Figure 26) to help keep concrete from sticking and also to lubricate the locking pin and spring.

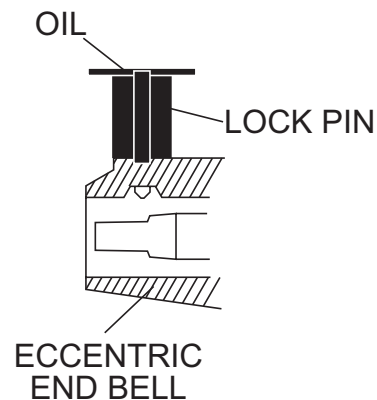

Figure 26. Quick Disconnect Lock

## Pivot Assembly (Frame)

Using a grease gun, apply a couple shots of lithium base grease to the pivot bearing assembly as required.

## BP-25H GAS VIBRATOR — PREPARATION FOR LONG -TERM STORAGE

For storage of the vibrator for over 30 days, the following is required:

- Drain the fuel tank completely, or add STA-BIL to the fuel.
- Run the engine until the gasoline in the carburetor is completely consumed.
- Completely drain the oil from the crankcase and refill with fresh oil.
- Remove the spark plug, pour 2 or 3 cc of SAE 30 oil into the cylinder and crank slowly to distribute the oil.
- Slowly rotate the engine a few times with the starter rope and install a new plug.
- Pull out the starter rope slowly and stop at the compression point.
- Clean all external parts of the engine and frame with a soft cloth.
- Cover the unit and store in a clean, dry place.

Go to [Discount-Equipment.com](http://Discount-Equipment.com) to order your parts

# BP-25H GASOLINE VIBRATOR — TROUBLESHOOTING (ENGINE)

Practically all breakdowns can be prevented by proper handling and maintenance inspections, but in the event of a breakdown, use Table 8 (Engine Troubleshooting) and Table 9 (Flexible Shaft Troubleshooting) as basic guideline for troubleshooting.

TABLE 8. ENGINE TROUBLESHOOTING		
SYMPTOM	POSSIBLE PROBLEM	SOLUTION
<b>Difficult to start</b>		
Fuel is available but spark plug will not ignite. (Power available at high tension cable).	Ignition plug being bridge?	Check ignition system.
	Carbon deposit at ignition?	Clean or replace ignition.
	Short circuit due to defective insulators?	Replace insulators.
	Improper spark gap?	Set spark plug gap to the correct gap.
Fuel is available but spark plug will not ignite. (Power <b>NOT</b> available at high tension cable).	Short circuit at stop switch?	Check stop switch circuit. Replace stop switch if defective.
	Ignition coil defective?	Replace ignition coil.
Fuel is available and spark plug ignites (compression <b>normal</b> ).	Muffler clogged with carbon deposits?	Clean or replace muffler.
	Mixed fuel quality is inadequate?	Check fuel to oil mixture.
	Fuel in use inadequate (water, dust)?	Flush fuel sytem and replace with fresh fuel.
	Air Cleaner clogged?	Clean or replace air cleaner.
Fuel is available and spark plug ignites (compression <b>low</b> ).	Defective cylinder head gasket?	Tighten cylinder head bolts or replace head gasket.
	Cylinder worn?	Replace cylinder.
	Spark plug loose?	Tighen spark plug.
<b>Operation not satisfactory</b>		
Not enough power available (compression normal, no miss-firing).	Air cleaner clogged?	Clean or replace air cleaner.
	Air in fuel line?	Bleed (remove air) from fuel line.
	Fuel level in carbureator float chamber improper?	Adjust carbureator float
	Carbon deposits in cylinder?	Clean or replace cylinder
Not enough power available (compression normal, miss-firing).	Ignition coil defective?	Flush fuel sytem and replace with fresh fuel.
	Ignition plug often shorts?	Replace ignition wires, clean ignition.
	Fuel in use inadequate (water, dust)?	Flush fuel sytem and replace with fresh fuel.
Engine overheats.	Excessive carbon deposition in combustion chamber?	Clean or replace crankcase.
	Exhaust or muffler clogged with carbon.	Clean or replace muffler.
	Spark plug heat value incorrect?	Replace spark plug with correct type spark plug.

# BP-25H GASOLINE VIBRATOR — TROUBLESHOOTING (ENGINE)

**TABLE 8. ENGINE TROUBLESHOOTING (Continued)**

SYMPTOM	POSSIBLE PROBLEM	SOLUTION
<b>Operation not satisfactory</b>		
Rotational speed fluctuates.	Governor adjustment improper?	Adjust governor to correct lever.
	Governor spring defective?	Clean or replace ignition.
	Fuel flow erratic?	Check fuel line.
	Air taken in through suction line?	Check suction line.
Recoil starter not working properly.	Dust in rotating part?	Clean recoil starter assembly.
	Spring spring failure?	Replace sprial spring.

**TABLE 9. FLEXIBLE SHAFT TROUBLESHOOTING**

SYMPTOM	POSSIBLE PROBLEM	SOLUTION
Flexible shaft is too hot to hold.	No lubrication?	Grease inner core.

# BP-25H GASOLINE VIBRATOR — EXPLANATION OF CODE IN REMARKS

The following section explains the different symbols and remarks used in the Parts section of this manual. Use the help numbers found on the back page of the manual if there are any questions.

The contents and part numbers listed in the parts section are subject to change **without notice**. Multiquip does not guarantee the availability of the parts listed.

Sample Parts List:

NO.	PART NO.	PART NAME	QTY.	REMARKS
1	12345	BOLT .....	1 .....	INCLUDES ITEMS W/*
2*		WASHER, 1/4 IN. ....		NOT SOLD SEPARATELY
2*	12347	WASHER, 3/8 IN. ...	1 .....	MQ-45T ONLY
3	12348	HOSE .....	A/R .....	MAKE LOCALLY
4	12349	BEARING .....	1 .....	S/N 2345B AND ABOVE

## NO. Column

**Unique Symbols** - All items with same unique symbol (\*, #, +, %, or >) in the number column belong to the same assembly or kit, which is indicated by a note in the "Remarks" column.

**Duplicate Item Numbers** - Duplicate numbers indicate multiple part numbers are in effect for the same general item, such as different size saw blade guards in use or a part that has been updated on newer versions of the same machine.



When ordering a part that has more than one item number listed, check the remarks column for help in determining the proper part to order.

## PART NO. Column

**Numbers Used** - Part numbers can be indicated by a number, a blank entry, or TBD.

TBD (To Be Determined) is generally used to show a part that has not been assigned a formal part number at time of publication.

A blank entry generally indicates that the item is not sold separately or is not sold by Multiquip. Other entries will be clarified in the "Remarks" Column.

## QTY. Column

**Numbers Used** - Item quantity can be indicated by a number, a blank entry, or A/R.

A/R (As Required) is generally used for hoses or other parts that are sold in bulk and cut to length.

A blank entry generally indicates that the item is not sold separately. Other entries will be clarified in the "Remarks" Column.

## REMARKS Column

Some of the most common notes found in the "Remarks" Column are listed below. Other additional notes needed to describe the item can also be shown.

**Assembly/Kit** - All items on the parts list with the same unique symbol will be included when this item is purchased.

Indicated by:

"INCLUDES ITEMS W/(unique symbol)"

**Serial Number Break** - Used to list an effective serial number range where a particular part is used.

Indicated by:

"S/N XXXXX AND BELOW"

"S/N XXXX AND ABOVE"

"S/N XXXX TO S/N XXX"

**Specific Model Number Use** - Indicates that the part is used only with the specific model number or model number variant listed. It can also be used to show a part is NOT used on a specific model or model number variant.

Indicated by:

"XXXXX ONLY"

"NOT USED ON XXXX"

**"Make/Obtain Locally"** - Indicates that the part can be purchased at any hardware shop or made out of available items. Examples include battery cables, shims, and certain washers and nuts.

**"Not Sold Separately"** - Indicates that an item cannot be purchased as a separate item and is either part of an assembly/kit that can be purchased, or is not available for sale through Multiquip.

# BP-25H GASOLINE VIBRATOR — SUGGESTED SPARE PARTS

## BP-25H GASOLINE VIBRATOR 1 TO 3 UNITS W/ HONDA GXH50QXA ENGINE

Qty.	P/N	Description
2	17211ZM7000 .....	ELEMENT AIR
3	9805655777 .....	SPARK PLUG (NKG)
3	28462ZM7003 .....	ROPE STARTER
1	17620ZL8003 .....	CAP, FUEL S/N 1159947 AND BELOW
1	17620ZL8013 .....	CAP, FUEL S/N 1159948 AND ABOVE
3	ZT37D5 .....	V-BELT, 6 GROOVE



Part number on this Suggested Spare Parts List may super cede/replace the P/N shown in the text pages of this book.

Go to Discount-Equipment.com to order your parts

# BP-25H GASOLINE VIBRATOR — NAMEPLATE AND DECALS ASSY.

NAMEPLATE AND DECALS ASSY.

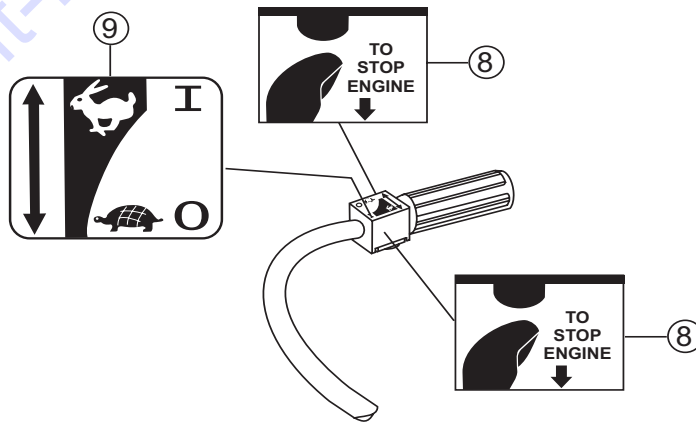
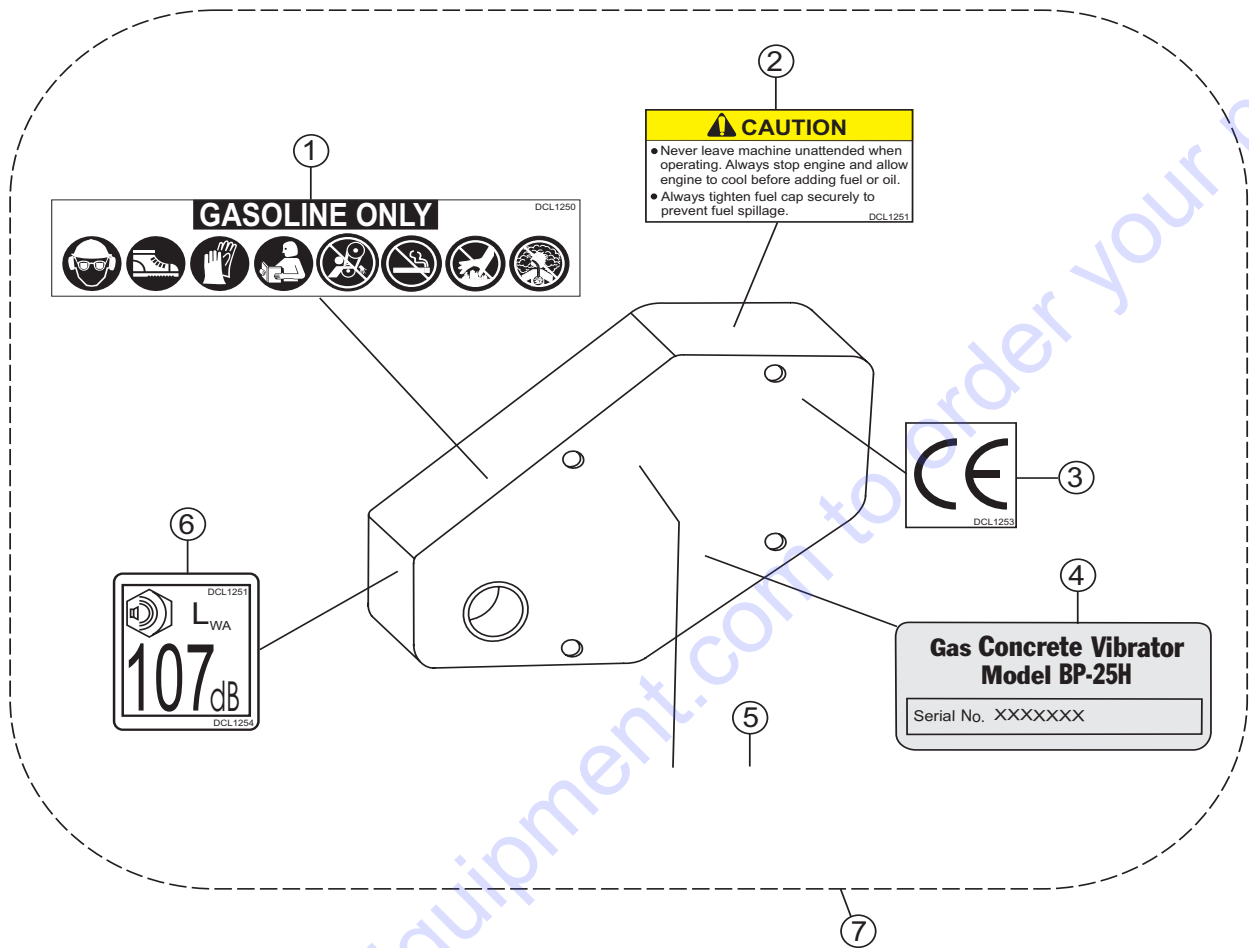

# BP-25H GASOLINE VIBRATOR — NAMEPLATE AND DECALS ASSY.

NAMEPLATE AND DECALS ASSY.

<u>NO.</u>	<u>PART NO.</u>	<u>PART NAME</u>	<u>QTY.</u>	<u>REMARKS</u>
1#		DECAL, MULTI/GASOLINE	1	
2#		DECAL, CAUTION	1	
3#		DECAL, CE LOGO	1	
4#		DECAL, NAMEPLATE .....	1	..... CONTACT MQ PARTS DEPT.
5#		DECAL, MQ LOGO	1	
6#		DECAL, NOISE LEVEL .....	1	..... INCLUDES ITEMS W#
7	DCLKITBP25	KIT, DECALS BP-25	1	
8	ZT101AE1	DECAL, STOP ENGINE	1	
9	ZT101AD1	DECAL, THROTTLE SPEED	1	

Go to Discount-Equipment.com to order your parts



# BP-25H GASOLINE VIBRATOR — VIBRATOR ASSY.

VIBRATOR ASSY.ASSY.

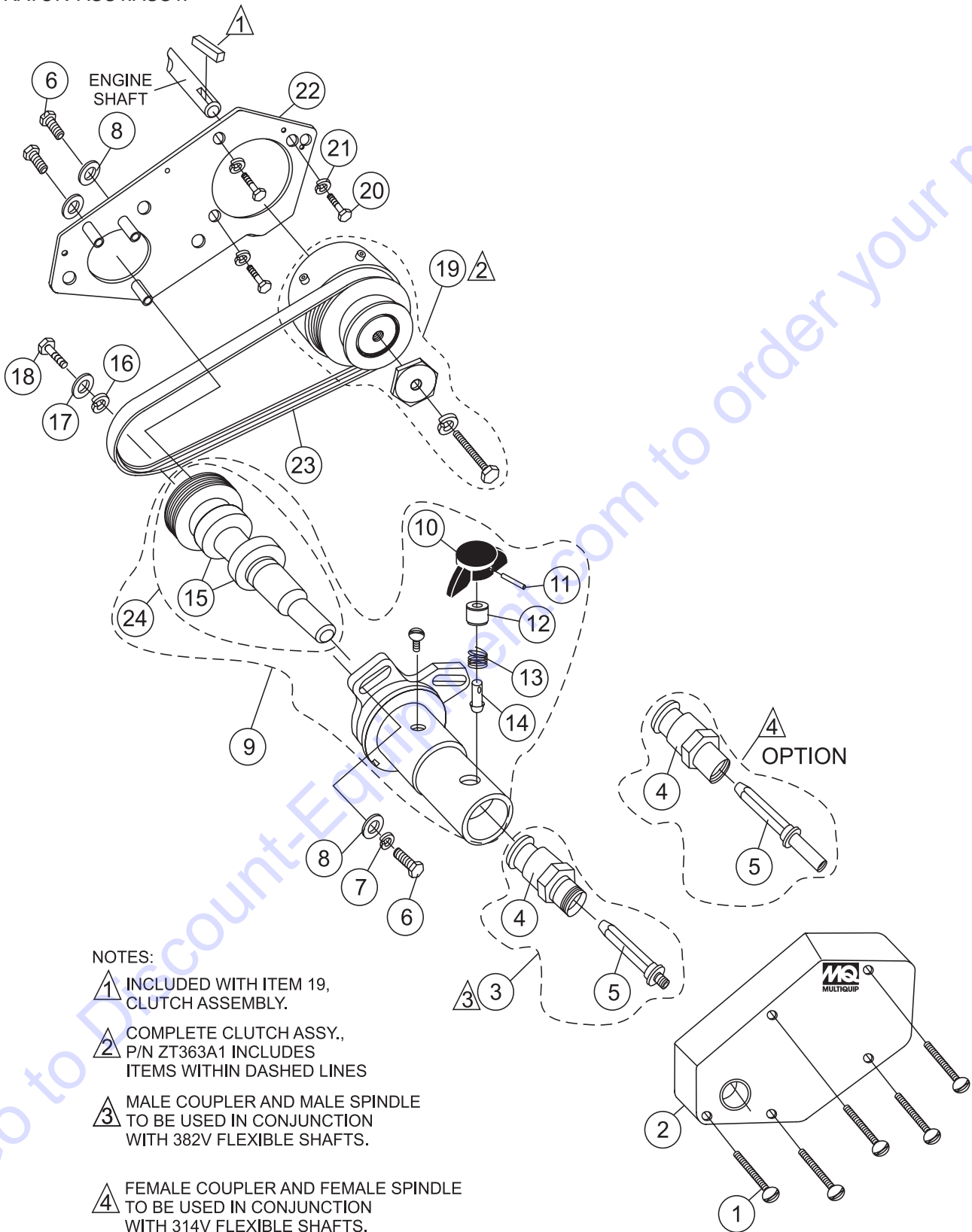

# PARTS FINDER

**Search Website  
by Part Number**



**Search Manual  
Library For Parts  
Manual & Lookup Part  
Numbers – Purchase  
or Request Quote**

**Search Manuals**

Enter your information to help us find the right parts manual for your machine.

\* Brand:

\* Model:

\* Serial:

\* Part Number:

SEARCH

**Can't Find Part or  
Manual? Request Help  
by Manufacturer,  
Model & Description**

**Parts Order Form**

Please fill in the following information to help us find the right part for your machine.

Manufacturer:	<input type="text"/>
Model:	<input type="text"/>
Description:	<input type="text"/>
Part Number:	<input type="text"/>
Quantity:	<input type="text"/>
Notes:	<input type="text"/>

Discount-Equipment.com is your online resource for quality parts & equipment.

Florida: **561-964-4949** Outside Florida TOLL FREE: **877-690-3101**

**Need parts?**

Click on this link: <http://www.discount-equipment.com/category/5443-parts/> and choose one of the options to help get the right parts and equipment you are looking for. Please have the machine model and serial number available in order to help us get you the correct parts. If you don't find the part on the website or on one of the online manuals, please fill out the request form and one of our experienced staff members will get back to you with a quote for the right part that your machine needs.

We sell worldwide for the brands: Genie, Terex, JLG, MultiQuip, Mikasa, Essick, Whiteman, Mayco, Toro Stone, Diamond Products, Generac Magnum, Airman, Haulotte, Barreto, Power Blanket, Nifty Lift, Atlas Copco, Chicago Pneumatic, Allmand, Miller Curber, Skyjack, Lull, Skytrak, Tsurumi, Husquvarna Target, Stow, Wacker, Sakai, Mi-T-M, Sullair, Basic, Dynapac, MBW, Weber, Bartell, Bennar Newman, Haulotte, Ditch Runner, Menegotti, Morrison, Contec, Buddy, Crown, Edco, Wyco, Bomag, Laymor, EZ Trench, Bil-Jax, F.S. Curtis, Gehl Pavers, Heli, Honda, ICS/PowerGrit, IHI, Partner, Imer, Clipper, MMD, Koshin, Rice, CH&E, General Equipment, Amida, Coleman, NAC, Gradall, Square Shooter, Kent, Stanley, Tamco, Toku, Hatz, Kohler, Robin, Wisconsin, Northrock, Oztec, Toker TK, Rol-Air, APT, Wylie, Ingersoll Rand / Doosan, Innovatech, Con X, Ammann, Mecalac, Makinex, Smith Surface Prep, Small Line, Wanco, Yanmar

# BP-25H GASOLINE VIBRATOR — VIBRATOR ASSY.

VIBRATOR ASSY.

<u>NO.</u>	<u>PART NO.</u>	<u>PART NAME</u>	<u>QTY.</u>	<u>REMARKS</u>
1	ZT111N109	10-32 X 2-3/4" SLOTTED PAN HEAD SCREW	7	
2	ZT346T1	BELT GUARD	1	
3	ZT1145AN1	QD ADAPTER .....	1	INCLUDES ITEMS W/*
4	36249	QD COUPLER, FEMALE .....	1	USED W/314V SHAFTS
4*	36248	QD COUPLER, MALE .....	1	USED W/382V SHAFTS
5	29957-001	SPINDLE SHAFT, FEMALE .....	1	USED W/314V SHAFTS
5*	25013-001	SPINDLE SHAFT, MALE .....	1	USED W/382V SHAFTS
6	ZT58A29	SCREW, HEX 5/16-18 X 7/8"	6	
7	ZT130A10	WASHER, SPLIT LOCK 5/16"	6	
8	ZT127A12	WASHER, FLAT STEEL 5/16"	6	
9	ZT6750K1	COUNTERSHAFT ASSEMBLY .....	1	INCLUDES ITEMS W/#
10#	ZT389A1	Q.D. RELEASE KNOB, PLASTIC	1	
11#	ZT81A78	PIN, SPRING 5/32 X 1"	1	
12#	ZT385B1	Q.D. PLUNGER GUIDE	1	
13#	ZT90G1	Q.D. SPRING, COMPRESSION	1	
14#	445C1	Q.D. PLUNGER PIN	1	
15#%	ZT207R4	SHAFT BEARING	2	
16	ZT130A9	WASHER, SPLIT LOCK MED 1/4"	1	
17	ZT127A11	WASHER, FLAT STEEL ZINC 1/4"	1	
18	ZT58A3	HEX HEAD CAP SCREW 1/4-20 X 3/4"	1	
19	ZT363A1	CLUTCH ASSEMBLY, COMPLETE	1	
20	ZT58B3	HEX HEAD CAP SCREW 1/4-28 X 3/4"	4	
21	ZT130A9	WASHER, LOCK MED 1/4"	4	
22	ZT386CT1	TRANS. MOUNTING PLATE	1	
23	ZT37D3	BP25 POLY V-BELT, 6 GROOVE	1	
24#	ZT229A1	DRIVEN SPINDLE ASSY.....	1	INCLUDES ITEMS W/%

# BP-25H GASOLINE VIBRATOR — FRAME ASSY.

FRAME ASSY.

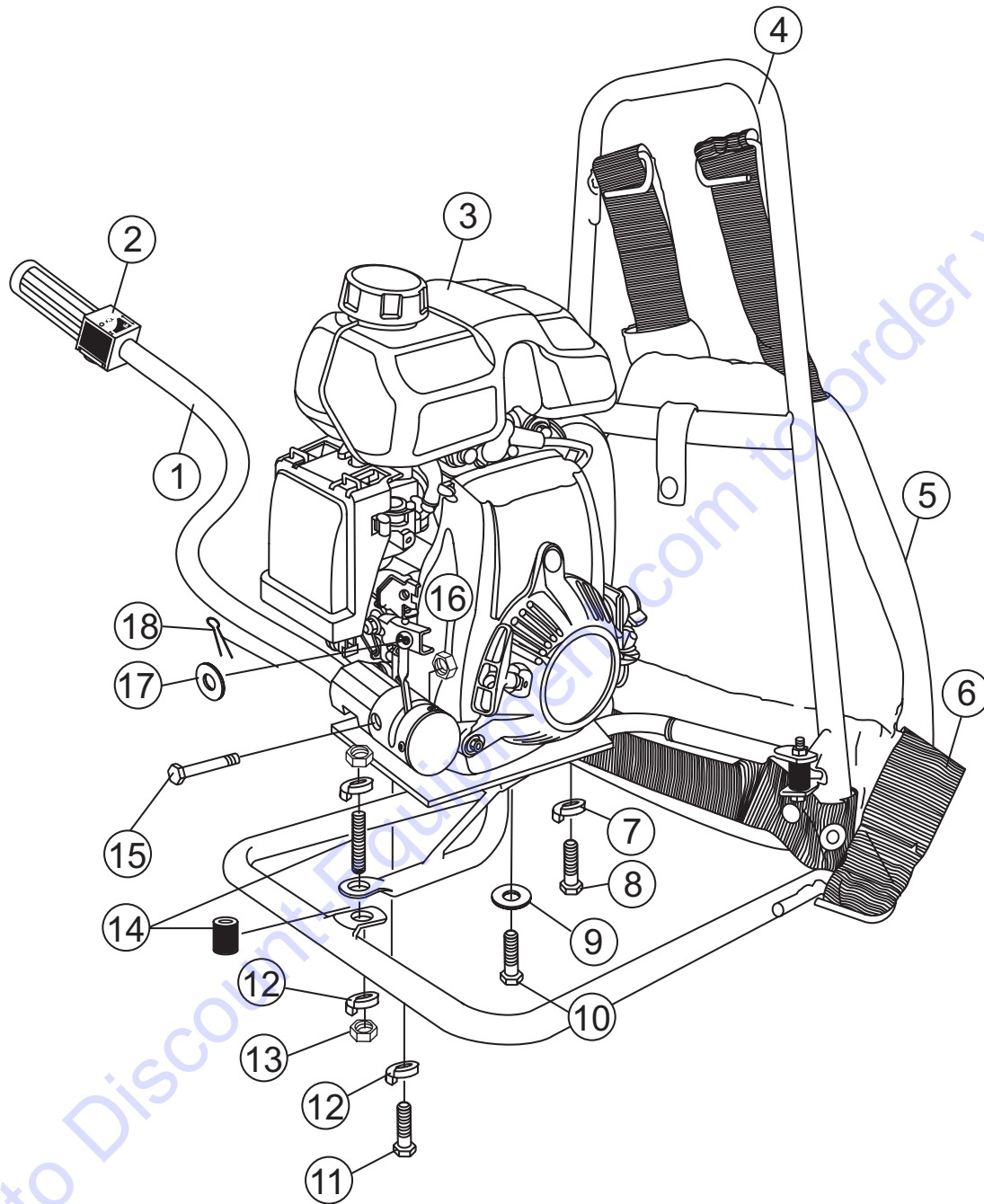

## BP-25H GASOLINE VIBRATOR — FRAME ASSY.

### FRAME ASSY.

<u>NO.</u>	<u>PART NO.</u>	<u>PART NAME</u>	<u>QTY.</u>	<u>REMARKS</u>
1	ZT316AG2	RH THROTTLE ARM ASSY.	1	
2	ZT177S1	KILL SWITCH, MOMENTARY PUSHBUTTON RED	1	
3	ZT6850X1	ENGINE, HONDA GXH50	1	
4	ZT374AR1	FRAME	1	
5	ZT45B1	BACKPACK PAD W/VELCRO STRAP	1	
6	ZT478C1	BACKPACK SHOULDER STRAP ASSY.	1	
7	ZT130A9	WASHER, SPLIT LOCK MED 1/4"	4	
8	ZT111T28	HEX HEAD CAP SCREW M6 X 20 MM	4	
9	ZT127A11	WASHER, FLAT STEEL ZINC 1/4"	1	
10	ZT58A1	HEX HEAD CAP SCREW 1/4-20 X 1/2"	1	
11	ZT58A27	HEX HEAD CAP SCREW 15/16-18 X 5/8"	2	
12	ZT130A10	WASHER, SPLIT LOCK 5/16"	8	
13	ZT72F2	NUT, HEX 5/16-18 X 1/2"	6	
14	ZT319D1	RUBBER SHOCK MOUNT W/STUD	3	
15	ZT58A8	HEX HEAD CAP SCREW 1/4-20 X 1-3/4"	1	
16	ZT74A8	1/4" NYLOCK HEX NUT	1	
17	ZT127A11	WASHER, FLAT STEEL ZINC 1/4"	1	
18	ZT81F8	COTTER PIN THROTTLE, 3/32 X 1/2"	1	

# HONDA GXH50QXA ENGINE — AIR CLEANER ASSY.

AIR CLEANER ASSY.

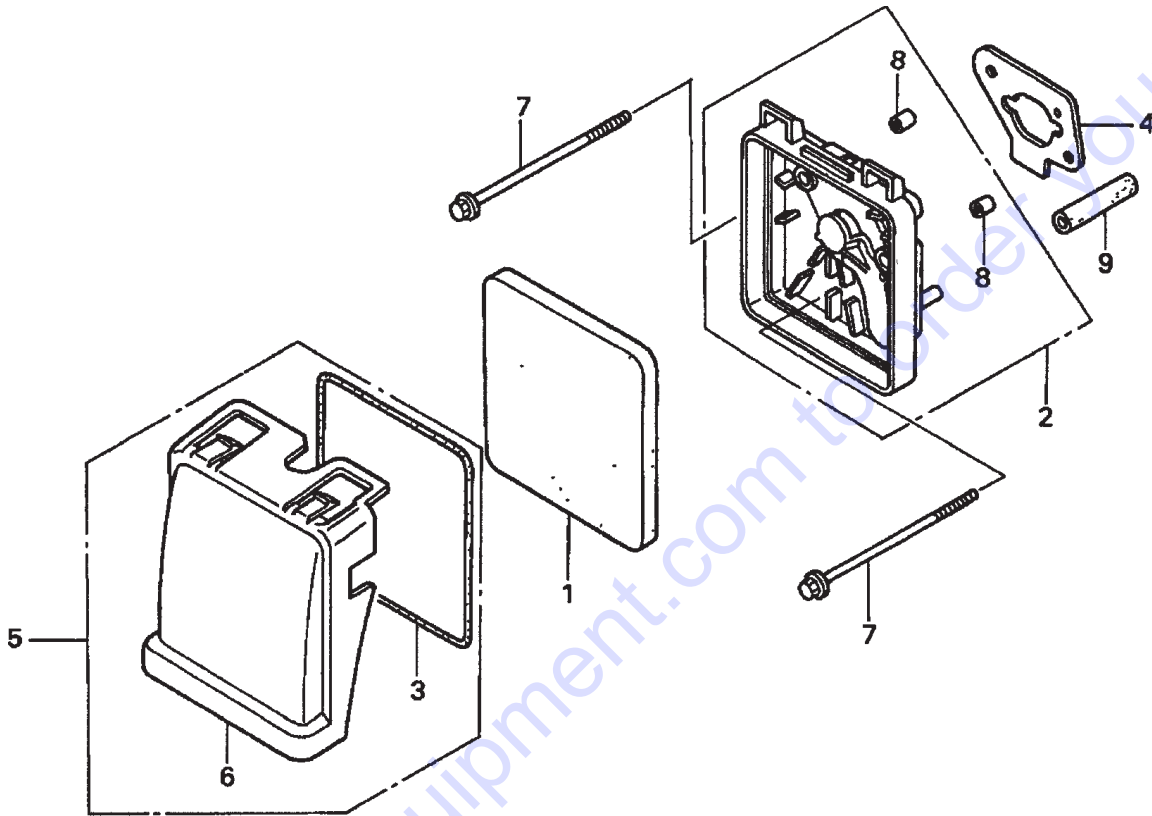

# HONDA GXH50QXA ENGINE — AIR CLEANER ASSY.

AIR CLEANER ASSY.

<u>NO.</u>	<u>PART NO.</u>	<u>PART NAME</u>	<u>QTY.</u>	<u>REMARKS</u>
1	17211ZM7000	AIR CLEANER ELEMENT	1	
2	17220ZM7000	AIR CLEANER HOUSING .....	1	INCLUDES ITEMS W/*
3#	17227ZM7000	AIR CLEANER SEAL	1	
4	17228ZM7000	AIR CLEANER GASKET	1	
5	17230ZM7000	AIR CLEANER COVER ASSY. ....	1	INCLUDES ITEMS W/#
6#	17231ZM7000	AIR CLEANER COVER	1	
7	90004ZM7000	FLANGE BOLT 5X75	2	
8*	91503ZM7000	AIR CLEANER COLLAR	2	
9	950057000330M	VACUUM BULK HOSE 7X3000 (7X75)	1	

Go to Discount-Equipment.com to order your parts

# HONDA GXH50QXA ENGINE — CAMSHAFT ASSY.

CAMSHAFT ASSY.

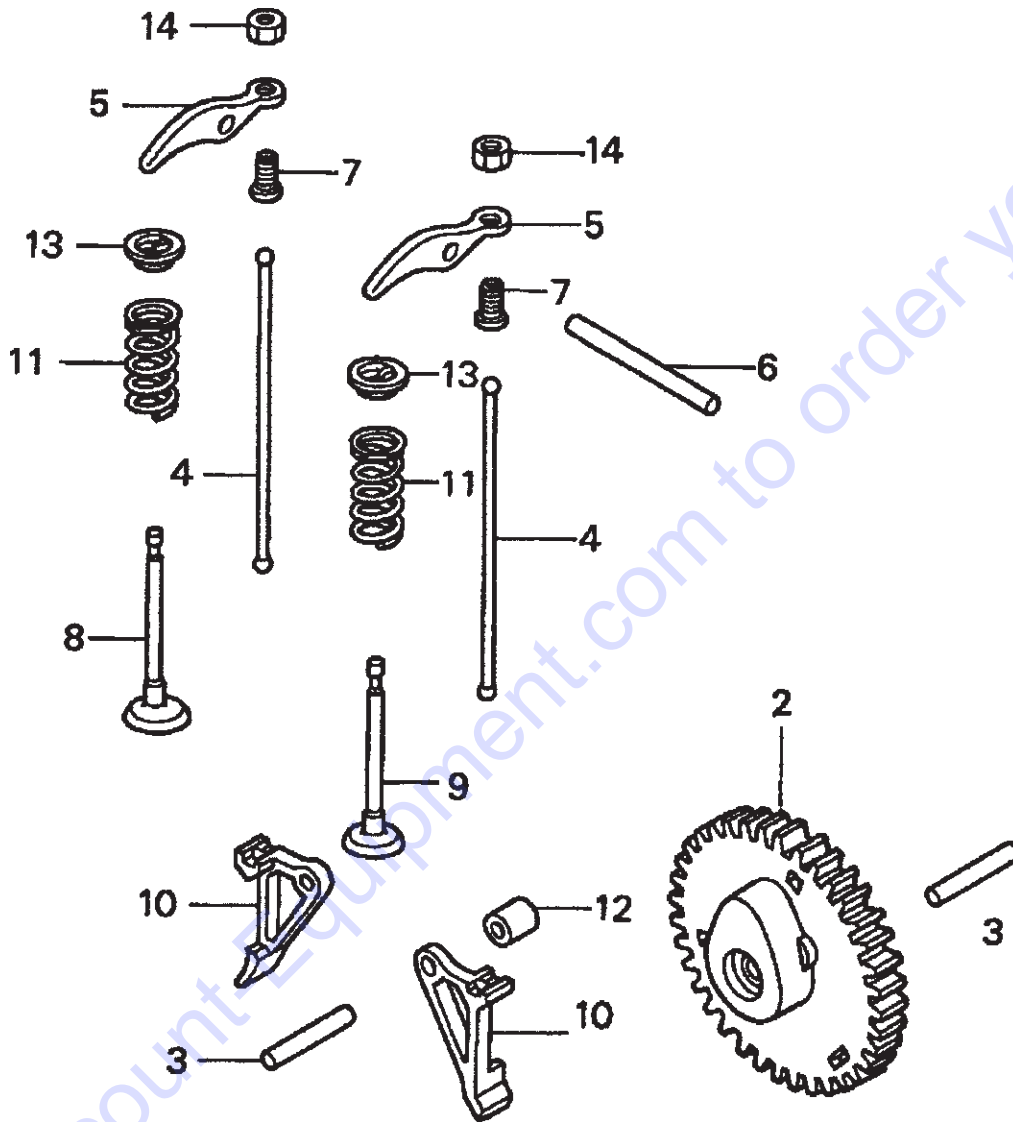



## HONDA GXH50QXA ENGINE — CAMSHAFT ASSY.

### CAMSHAFT ASSY.

<u>NO.</u>	<u>PART NO.</u>	<u>PART NAME</u>	<u>QTY.</u>	<u>REMARKS</u>
2	14100ZM7010	CAMSHAFT ASSY.	1	
3	14126Z0G003	ROLLER 5X29.8	2	
3	90702P6R008	OIL PUMP PIN	2	
4	14410ZM7000	PUSH ROD	2	
5	14431ZM7000	VALVE ROCKER ARM	2	
6	14435ZM7003	ROLLER 4X37.8	1	
7	14451ZM7000	ROCKER ARM PIVOT	2	
8	14711ZM7000	IN. VALVE	1	
9	14721ZM7000	EX. VALVE	1	
10	14731ZM7013	LIFTER VALVE	2	
11	14751ZM7000	VALVE SPRING	2	
12	14754ZM7000	LIFTER COLLAR	1	
13	14771ZM3000	VALVE SPRING RETAINER	2	
14	90206KM3000	TAPPET ADJ. NUT	2	

Go to Discount-Equipment.com to order your parts



# HONDA GXH50QXA ENGINE — CARBURETOR ASSY.

## CARBURETOR ASSY.

<u>NO.</u>	<u>PART NO.</u>	<u>PART NAME</u>	<u>QTY.</u>	<u>REMARKS</u>
1*	16010ZG1015	GASKET SET	1	
2*	16011ZE0005	FLOAT VALVE SET	1	
3*	16013ZG0811	FLOAT SET	1	
7*	16028ZG0811	SCREW SET	1	
8*	16044ZM7003	CHOKE SET	1	
9	16100ZM7G11	CARBURETOR ASSY. (BF32E A) .....	1	INCLUDES ITEMS W/* S/N 1068857 AND BELOW
9	16100ZM7G13	CARBURETOR ASSY. (BF32E C) .....	1	INCLUDES ITEMS W/* S/N 1068858 AND ABOVE
10*	16124ZE0005	THROTTLE STOP SCREW	1	
11*	16166ZM7003	MAIN NOZZLE	1	
13	16211ZM7000	CARBURETOR INSULATOR	1	
14	16212ZM7000	INSULATOR GASKET	1	
15	16221ZG0801	CARBURETOR GASKET	1	
16*	16953ZG0812	VALVE LEVER	1	
17*	16954ZE1812	LEVER SETTING PLATE	1	
18*	16956ZE1811	LEVER SPRING VALVE	1	
19*	16957ZE1812	VALVE GASKET	1	
21	93500030060H	PAN SCREW	2	
22	99101ZG00500	MAIN JET #50, OPTIONAL	1	
22	99101ZG00520	MAIN JET #52, OPTIONAL	1	
22*	99101ZG00550	MAIN JET #55	1	
23*	99204ZE20350	PILOT JET SET #35	1	
24*	16015ZG0811	FLOAT CHAMBER SET	1	
25*	16024ZE1811	DRAIN SCREW SET	1	
26*	16016ZH7W01	SCREW SET	1	

# HONDA GXH50QXA ENGINE — CONTROL ASSY.

CONTROL ASSY.

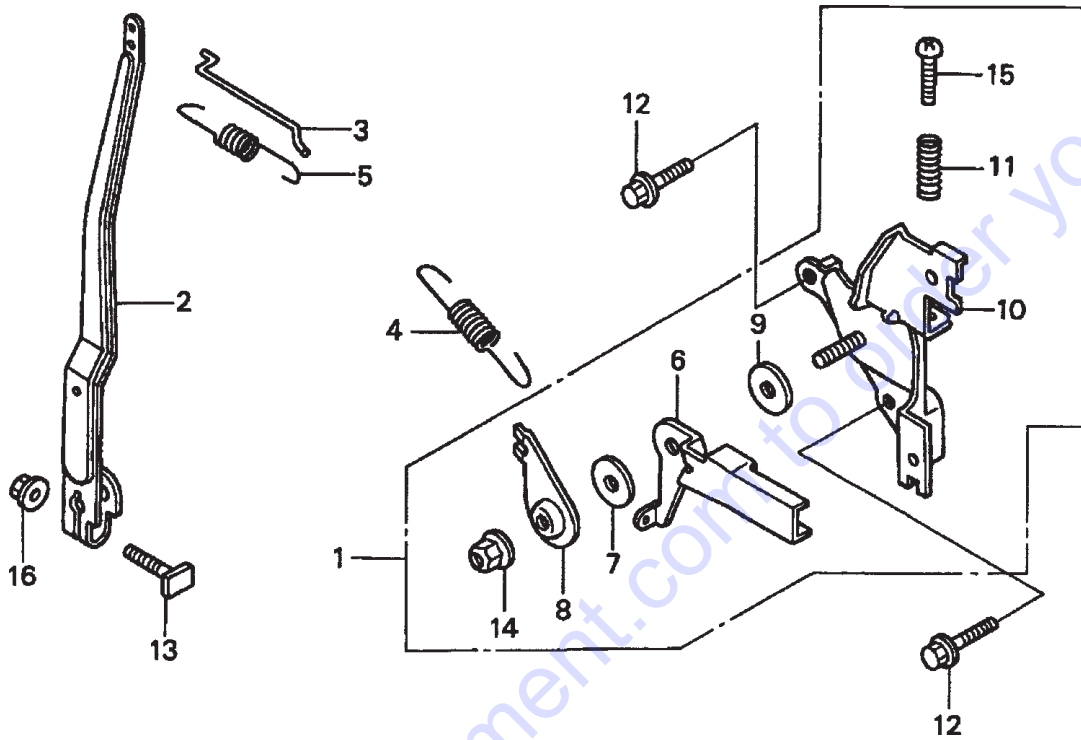

# HONDA GXH50QXA ENGINE — CONTROL ASSY.

CONTROL ASSY.

<u>NO.</u>	<u>PART NO.</u>	<u>PART NAME</u>	<u>QTY.</u>	<u>REMARKS</u>
1	16500ZM7000	CONTROL ASSY. ....	1	INCLUDES ITEMS W/*
2	16551ZM7000	GOVERNOR ARM	1	
3	16555ZM7000	GOVERNOR ROD	1	
4	16561ZM7000	GOVERNOR SPRING	1	
5*	16562ZM7000	THROTTLE RETURN SPRING	1	
6*	16571ZM7000	CONTROL LEVER	1	
7*	16574ZE1000	LEVER SPRING	1	
8*	16575ZH8000	CONTROL LEVER WASHER	1	
9*	16578ZE1000	CONTROL LEVER SPACER	1	
10*	16580ZM7000	CONTROL BASE	1	
11*	16584ZE3790	CONTROL ADJUSTING SPRING	1	
12	90003892000	FLANGE BOLT	2	
13	90015ZE5010	GOVERNOR ARM BOLT	1	
14*	90114SA0000	SELF LOCK NUT, 6MM	1	
15*	93500050200A	PAN SCREW, 5X20	1	
16	9405006000	FLANGE NUT, 6MM	1	

Go to Discount-Equipment.com to order your parts

# HONDA GXH50QXA ENGINE — CRANKCASE COVER ASSY.

CRANKCASE COVER ASSY.

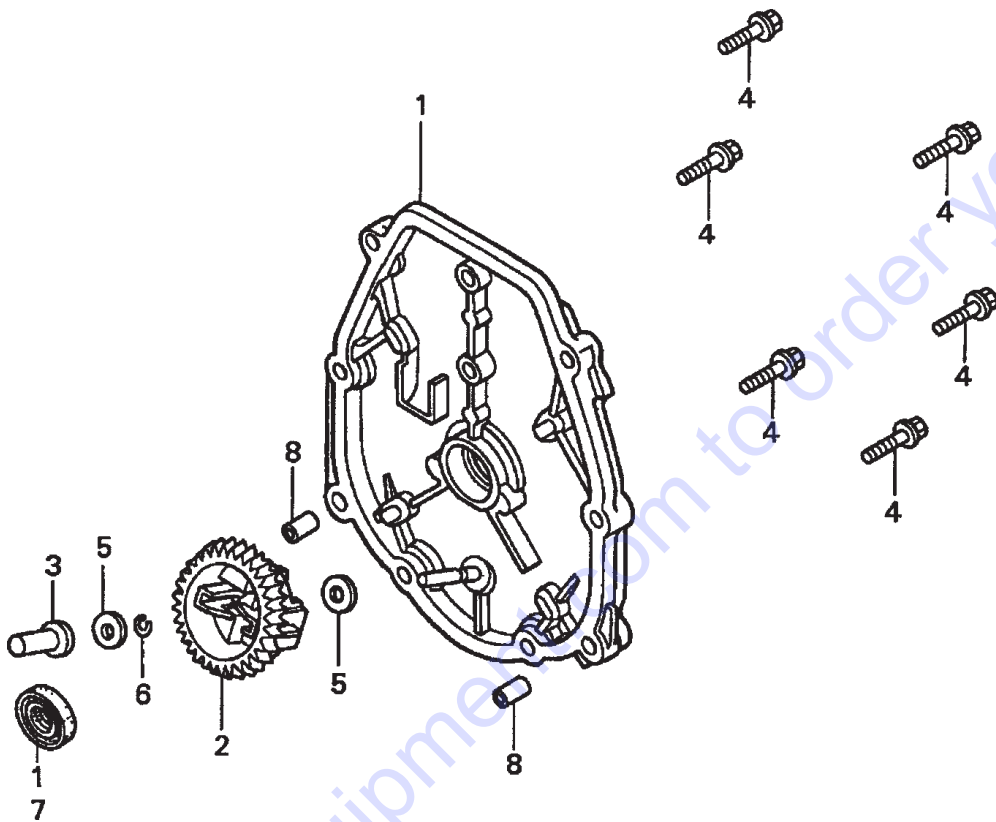

# HONDA GXH50QXA ENGINE — CRANKCASE COVER ASSY.

## CRANKCASE COVER ASSY.

<u>NO.</u>	<u>PART NO.</u>	<u>PART NAME</u>	<u>QTY.</u>	<u>REMARKS</u>
1	11340ZM7801	CRANKCASE SIDE COVER .....	1	S/N 1199157 AND BELOW
1	11340ZM7802	CRANKCASE SIDE COVER .....	1	S/N 1199158 AND ABOVE
2	16510ZM7000	GOVERNOR ASSY.	1	
3	16531ZM7000	GOVERNOR SLIDER	1	
4	90006ZM7000	FLANGE BOLT, 5X23	6	
5	90441ZM7000	WASHER, 4.2X13	2	
6	90602ZM7000	GOVERNOR HOLDER CLIP	1	
7	91202HC5005	OIL SEAL, 17X27X5 (KOYO)	1	
8	9430106100	DOWEL PIN A 6X10	2	

Go to Discount-Equipment.com to order your parts

# HONDA GXH50QXA ENGINE — CRANKSHAFT/BALANCER ASSY.

CYLINDER BARREL ASSY.

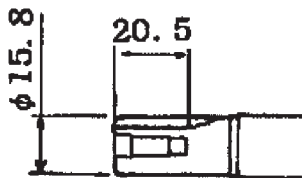
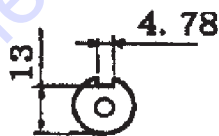
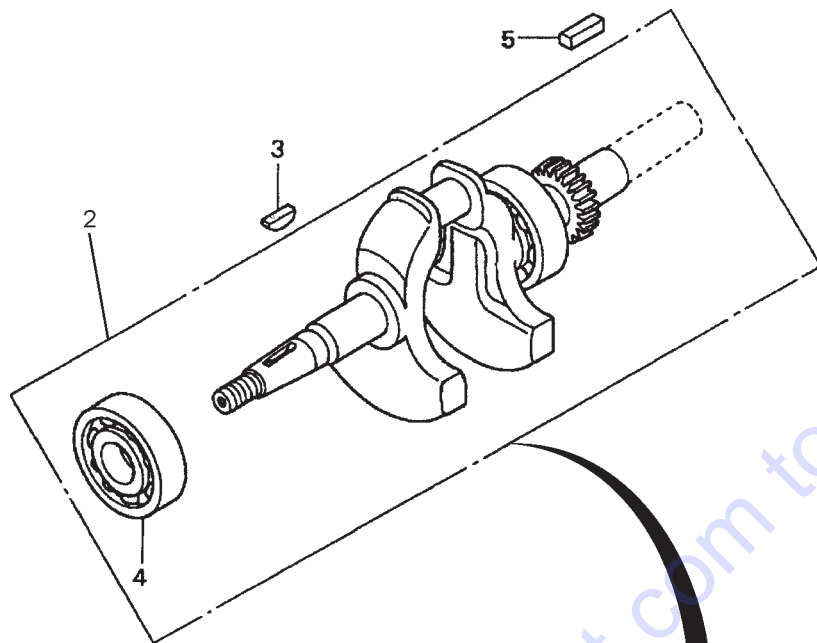



# HONDA GXH50QXA ENGINE — CRANKSHAFT/BALANCER ASSY.

## CRANKSHAFT/BALANCER ASSY.

<u>NO.</u>	<u>PART NO.</u>	<u>PART NAME</u>	<u>QTY.</u>	<u>REMARKS</u>
2	13310ZM7800	CRANKSHAFT .....	1	INCLUDES ITEMS W/*
3	13331ZM7000	SPECIAL KEY	1	
4*	961006203000	RADIAL BALL BEARING	1	
5	90741ZM7000	KEY 4.78MM, OPTIONAL	1	

Go to Discount-Equipment.com to order your parts

# HONDA GXH50QXA ENGINE — CYLINDER BARREL ASSY.

CYLINDER BARREL ASSY.

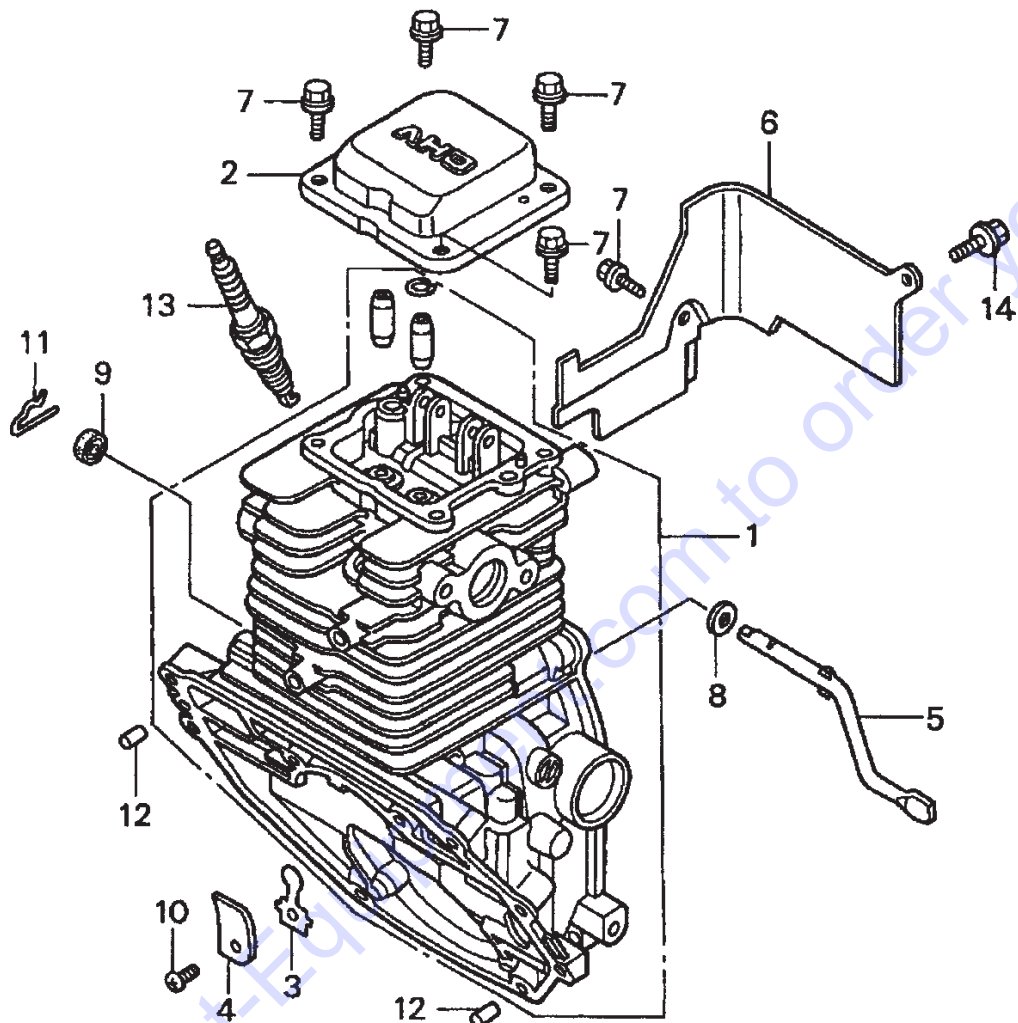

## HONDA GXH50QXA ENGINE — CYLINDER BARREL ASSY.

### CYLINDER BARREL ASSY.

<u>NO.</u>	<u>PART NO.</u>	<u>PART NAME</u>	<u>QTY.</u>	<u>REMARKS</u>
1	12100ZM7000	CYLINDER	1	
2	12311ZM7000	HEAD COVER	1	
3	15571ZM7003	OIL OUTLET VALVE	1	
4	15572ZM7000	STOPPER PLATE	1	
5	16541ZM7000	GOVERNOR ARM SHAFT	1	
6	19631ZM7000	SHROUD	1	
7	90003892000	FLANGE BOLT 5X12	5	
8	90443ZC3000	WASHER 5.2X9	1	
9	91231ZC3003	OIL SEAL 5X11X5	1	
10	93500030050A	PAN SCREW 3X5	1	
11	9425106000	LOCK PIN 6MM	1	
12	9622060150	ROLLER 6X15	2	
13	9805655757	SPARK PLUG U16SFR-UB (DENSO)	1	
13	9805655777	SPARK PLUG CR5HSB (NKG)	1	
14	90003892000	FLANGE BOLT 5X12	1	

# HONDA GXH50QXA ENGINE — FAN COVER ASSY.

FAN COVER ASSY.

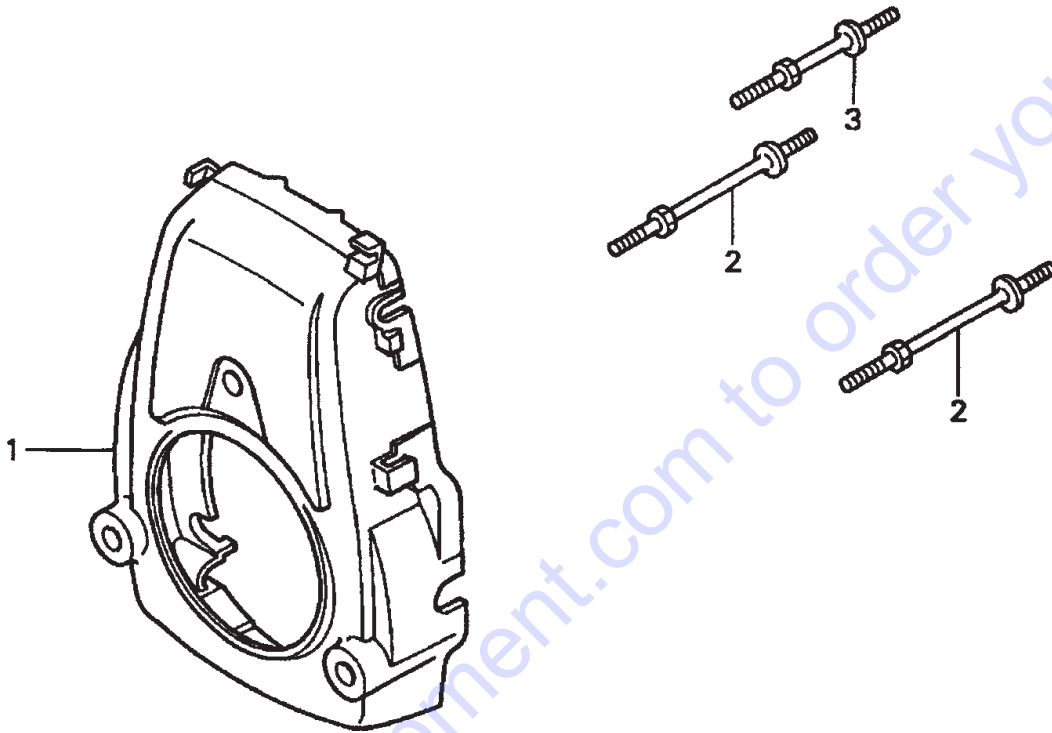

## HONDA GXH50QXA ENGINE — FAN COVER ASSY.

FAN COVER ASSY.

<u>NO.</u>	<u>PART NO.</u>	<u>PART NAME</u>	<u>QTY.</u>	<u>REMARKS</u>
1	19610ZM7000ZA	FAN COVER *R8* BRIGHT RED	1	
2	90042ZM7000	STUD BOLT A	2	
3	90043ZM7000	STUD BOLT B	1	

Go to Discount-Equipment.com to order your parts

# HONDA GXH50QXA ENGINE — FLYWHEEL + IGNITION COIL ASSY.

FLYWHEEL AND IGNITION COIL ASSY.

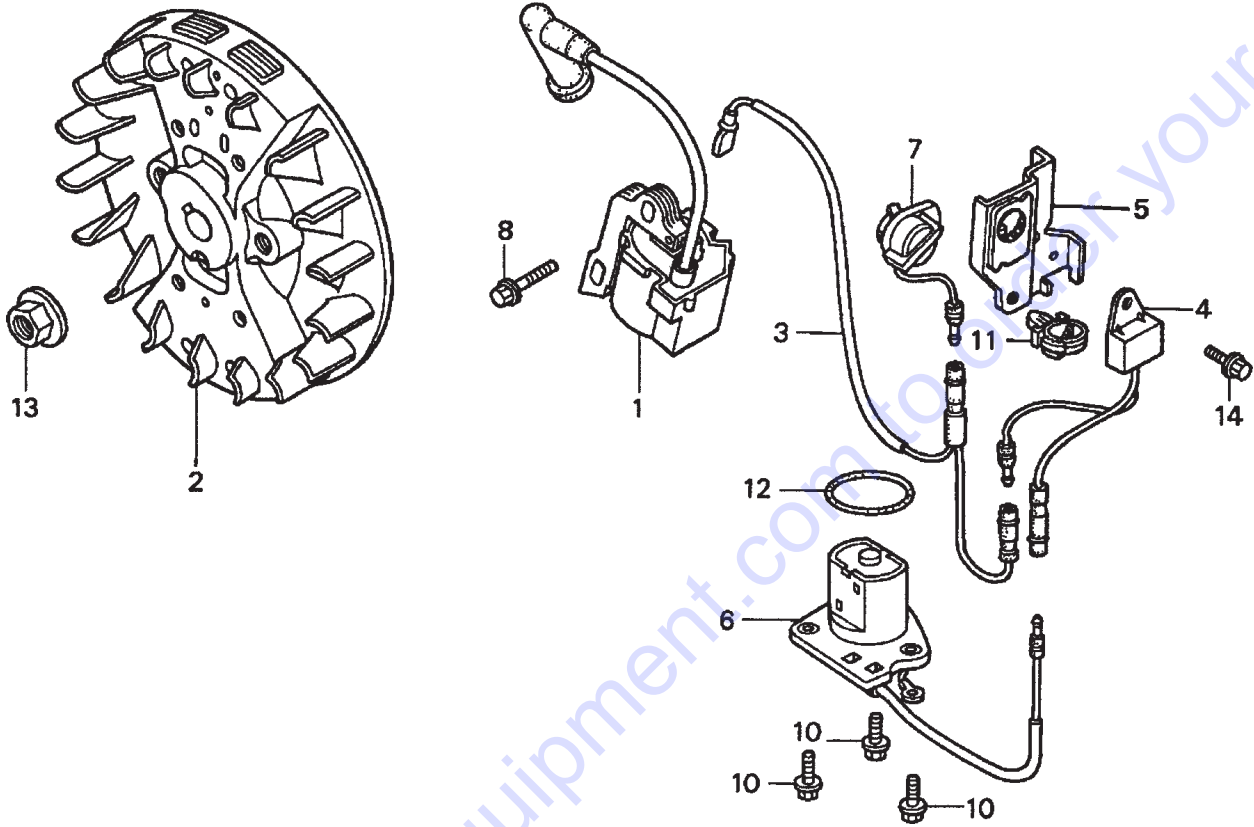

## HONDA GXH50QXA ENGINE — FLYWHEEL AND IGNITION COIL ASSY.

### FLY WHEEL AND IGNITION COIL ASSY.

<u>NO.</u>	<u>PART NO.</u>	<u>PART NAME</u>	<u>QTY.</u>	<u>REMARKS</u>
1	30500ZM7004	IGNITION COIL ASSY.	1	
2	31110ZM7004	FLYWHEEL	1	
3	32195ZM7800	STOP SWITCH WIRE	1	
4	34150ZH7003	OIL ALERT UNIT	1	
5	35124ZM7800	STOP SWITCH BRACKET	1	
6	35480ZM7801	OIL LEVEL SWITCH ASSY.	1	
7	36100ZE1015	ENGINE STOP SWITCH ASSY.	1	
8	90004ZC3000	FLANGE BOLT 5X20	1	
10	90012896750	FLANGE BOLT 5X14	3	
11	90684ZA0601	WIRE HARNESS CLIP	1	
12	91301ZA8003	O-RING	1	
13	9405010000	FLANGE NUT 10MM	1	
14	957010600800	FLANGE BOLT 6X8	1	

Go to Discount-Equipment.com to order your parts

# HONDA GXH50QXA ENGINE — FUEL TANK ASSY.

FUEL TANK ASSY.

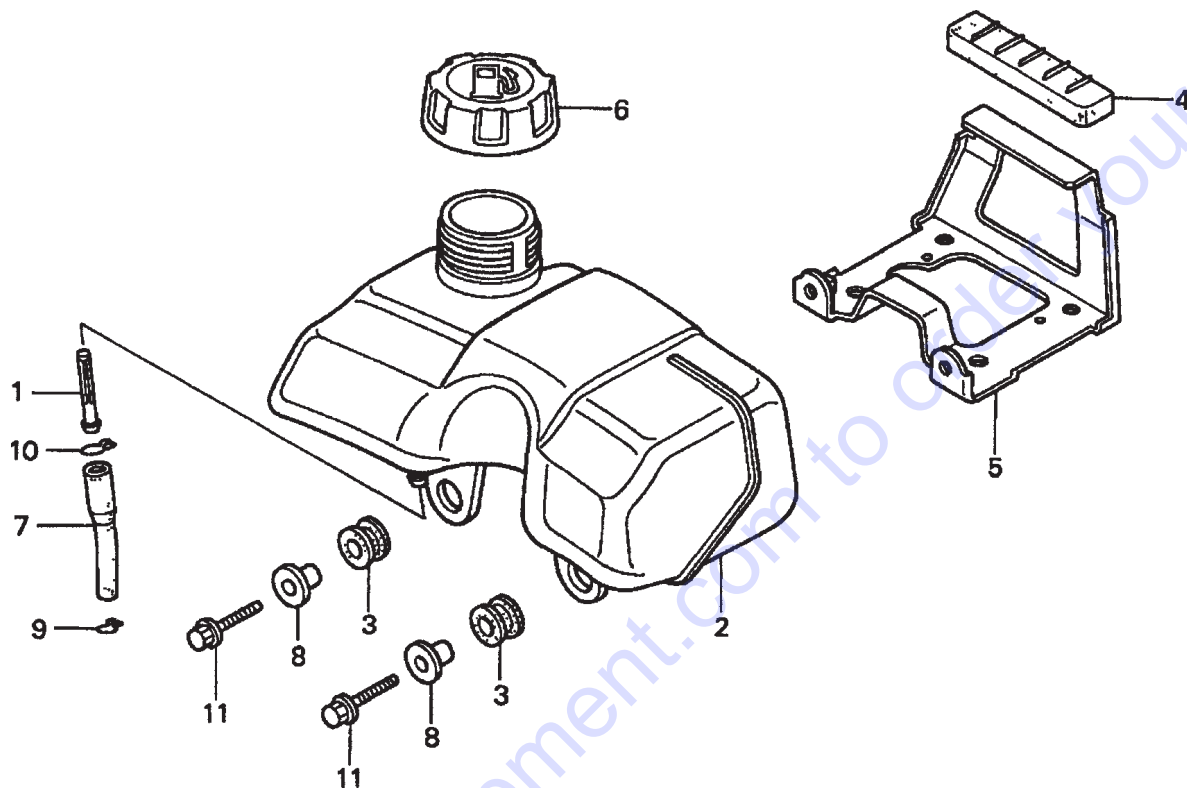



# HONDA GXH50QXA ENGINE — FUEL TANK ASSY.

## FUEL TANK ASSY.

<u>NO.</u>	<u>PART NO.</u>	<u>PART NAME</u>	<u>QTY.</u>	<u>REMARKS</u>
1	16952ZE6000	FUEL FILTER	1	
2	17511ZM7000	FUEL TANK	1	
3	17532ZM7000	TANK MOUNTING RUBBER A	2	
4	17533ZM7000	TANK MOUNTING RUBBER B	1	
5	17560ZM7000	FUEL TANK STAY	1	
6	17620ZL8003	FUEL TANK CAP ASSY. ....	1	.....S/N 1159947 AND BELOW
6	17620ZL8013	FUEL TANK CAP ASSY. ....	1	.....S/N 1159948 AND ABOVE
7	17701ZM7000	FUEL TUBE A	1	
8	19052MB4880	CANISTER MOUNT COLLAR	2	
9	8599292979	TUBE CLIP B8	1	
10	9500202120	TUBE CLIP B12	1	
11	957010602007	FLANGE BOLT 6X20	2	

Go to Discount-Equipment.com to order your parts

# HONDA GXH50QXA ENGINE — OIL CASE ASSY.

OIL CASE ASSY.

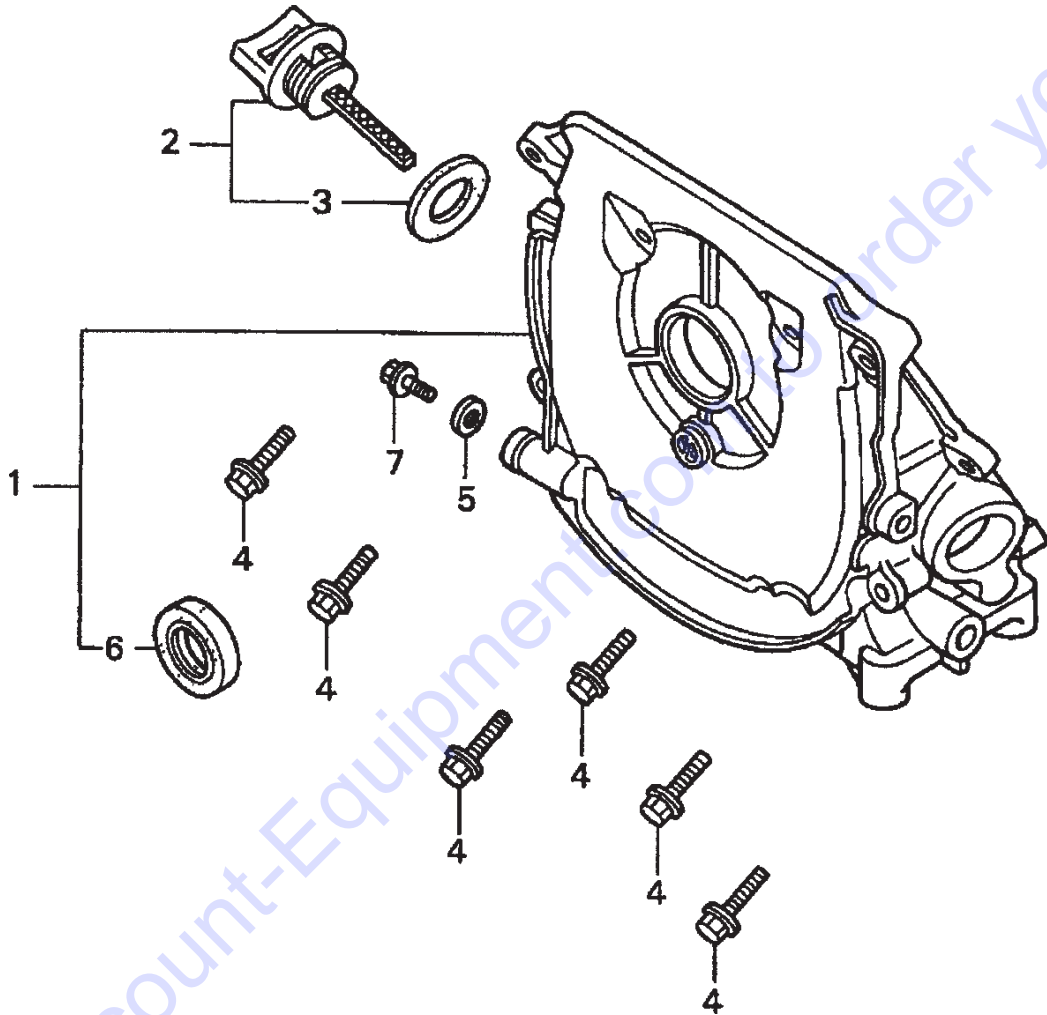

# HONDA GXH50QXA ENGINE — OIL CASE ASSY.

OIL CASE ASSY.

<u>NO.</u>	<u>PART NO.</u>	<u>PART NAME</u>	<u>QTY.</u>	<u>REMARKS</u>
1	11300ZM7800	OIL CASE ASSY. ....	1	INCLUDES ITEMS W/*
2	15600ZM7003	OIL FILLER CAP ASSY. ....	1	INCLUDES ITEMS W/#
3#	15625ZE1003	OIL FILLER CAP GASKET	1	
4	90006ZM7000	FLANGE BOLT 5X23	8	
5	90471580000	WASHER 8MM	1	
6*	91202HC5005	OIL SEAL 17X27X5 (KOYO)	1	
7	957010801208	FLANGE BOLT 8X12	1	

Go to Discount-Equipment.com to order your parts

# HONDA GXH50QXA ENGINE — PISTON AND CONNECTING ROD ASSY.

PISTON AND CONNECTING ROD ASSY.

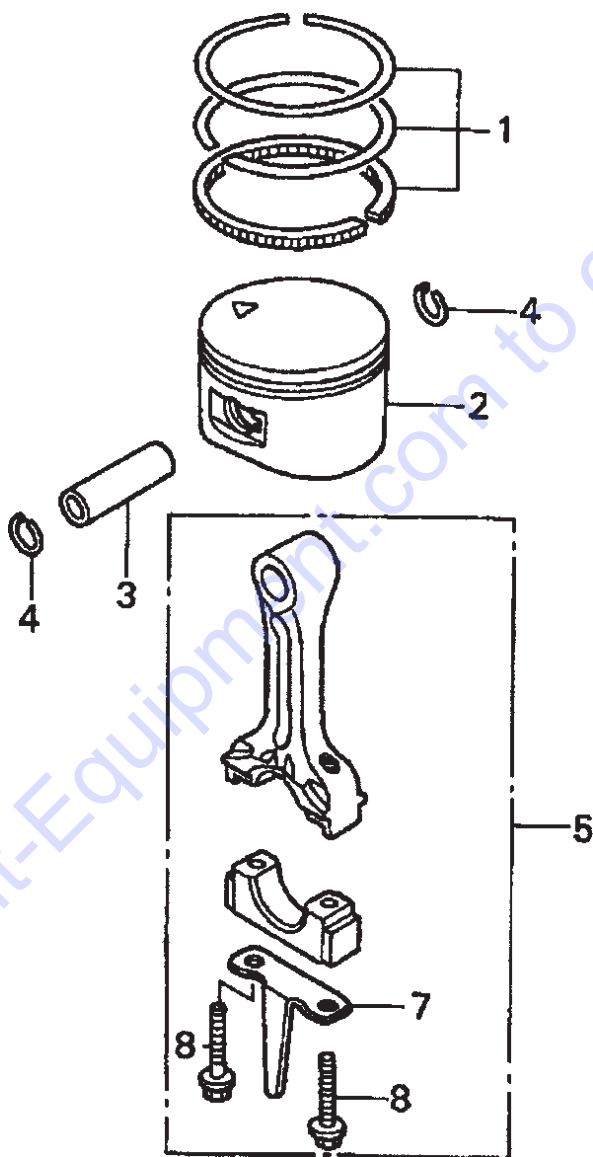

# HONDA GXH50QXA ENGINE — PISTON AND CONNECTING ROD ASSY.

## PISTON AND CONNECTING ROD ASSY.

<u>NO.</u>	<u>PART NO.</u>	<u>PART NAME</u>	<u>QTY.</u>	<u>REMARKS</u>
1	13010ZM7000	PISTON RING SET, STANDARD	1	
2	13101ZM7010	PISTON, STANDARD	1	
3	13111GS7000	PISTON PIN	1	
4	13115147000	PISTON PIN CLIP	2	
5	13200ZM7000	CONNECTING ROD ASSY. ....	1	..... INCLUDES ITEMS W/*
7*	13281ZM7000	CONNECTING ROD DIPPER	1	
8*	90001ZM7000	CONNECTING ROD BOLT	2	

Go to Discount-Equipment.com to order your parts

# HONDA GXH50QXA ENGINE — RECOIL STARTER ASSY.

RECOIL STARTER ASSY.

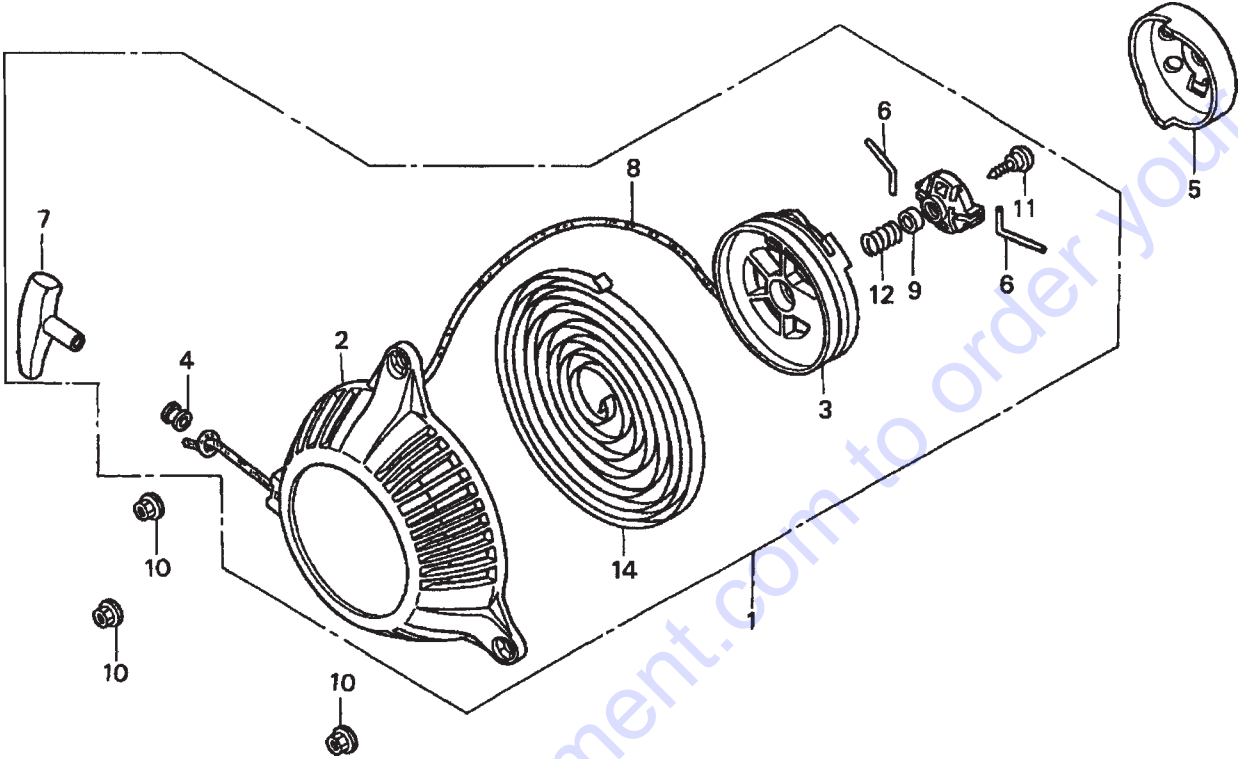

## HONDA GXH50QXA ENGINE — RECOIL STARTER ASSY.

### RECOIL STARTER ASSY.

<u>NO.</u>	<u>PART NO.</u>	<u>PART NAME</u>	<u>QTY.</u>	<u>REMARKS</u>
1	28400ZM7003	RECOIL STARTER ASSY. ....	1	INCLUDES ITEMS W/*
2*	28414ZM7003	RECOIL STARTER CASE	1	
3*	28421ZM7003	RECOIL STARTER REEL	1	
4*	28433ZM3003	ROPE GUIDE	1	
5	28451ZM7003	RECOIL STARTER PULLEY	1	
6*	28459ZM7003	SWINGARM	2	
7*	28461ZM3003	RECOIL STARTER KNOB	1	
8*	28462ZM7003	RECOIL STARTER ROPE #3.5X52	1	
9*	91504ZM7003	COLLAR	1	
10	9405005000	FLANGE NUT 5MM	3	
11*	90012ZM3003	SETTING SCREW	1	
12*	28404968004	FRICTION SPRING	1	
14*	28442ZH8003	RECOIL STARTER SPRING	1	

Go to Discount-Equipment.com to order your parts

# HONDA GXH50QXA ENGINE — LABELS ASSY.

LABELS ASSY.

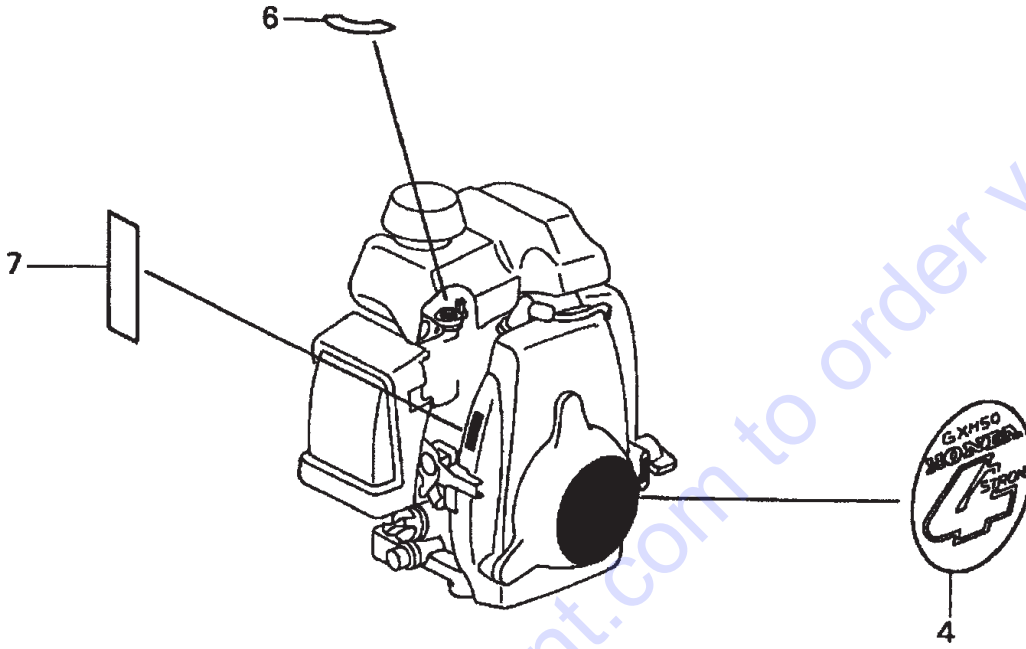



# HONDA GXH50QXA ENGINE — LABELS ASSY.

LABELS ASSY.

<u>NO.</u>	<u>PART NO.</u>	<u>PART NAME</u>	<u>QTY.</u>	<u>REMARKS</u>
4	87521ZM7000	EMBLEM	1	
6	87528ZG0W40	PETCOCK MARK, EXTERNAL	1	
7	87532ZM3G00	THROTTLE INDICATION MARK	1	

Go to Discount-Equipment.com to order your parts

# HONDA GXH50QXA ENGINE — TOOLS ASSY.

TOOLS ASSY.

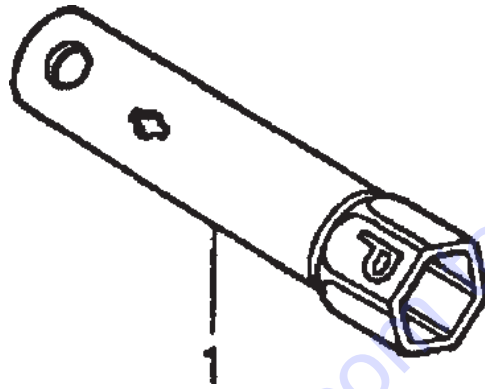

# HONDA GXH50QXA ENGINE — TOOLS ASSY.

TOOLS ASSY.

<u>NO.</u>	<u>PART NO.</u>	<u>PART NAME</u>	<u>QTY.</u>	<u>REMARKS</u>
1	89216130690	SPARK PLUG WRENCH, OPTIONAL	1	

Go to Discount-Equipment.com to order your parts

# PARTS FINDER

**Search Website  
by Part Number**



**Search Manual  
Library For Parts  
Manual & Lookup Part  
Numbers – Purchase  
or Request Quote**

**Search Manuals**

Enter your information to help us find the right parts manual for your machine.

\* Brand:

\* Model:

\* Serial:

\* Part Number:

SEARCH

**Can't Find Part or  
Manual? Request Help  
by Manufacturer,  
Model & Description**

**Parts Order Form**

Please fill in the following information to help us find the right part for your machine.

Manufacturer:	<input type="text"/>
Model:	<input type="text"/>
Description:	<input type="text"/>
Part Number:	<input type="text"/>
Quantity:	<input type="text"/>
Notes:	<input type="text"/>

Submit

Discount-Equipment.com is your online resource for quality parts & equipment.

Florida: **561-964-4949** Outside Florida TOLL FREE: **877-690-3101**

**Need parts?**

Click on this link: <http://www.discount-equipment.com/category/5443-parts/> and choose one of the options to help get the right parts and equipment you are looking for. Please have the machine model and serial number available in order to help us get you the correct parts. If you don't find the part on the website or on one of the online manuals, please fill out the request form and one of our experienced staff members will get back to you with a quote for the right part that your machine needs.

We sell worldwide for the brands: Genie, Terex, JLG, MultiQuip, Mikasa, Essick, Whiteman, Mayco, Toro Stone, Diamond Products, Generac Magnum, Airman, Haulotte, Barreto, Power Blanket, Nifty Lift, Atlas Copco, Chicago Pneumatic, Allmand, Miller Curber, Skyjack, Lull, Skytrak, Tsurumi, Husquvarna Target, Stow, Wacker, Sakai, Mi-T-M, Sullair, Basic, Dynapac, MBW, Weber, Bartell, Bennar Newman, Haulotte, Ditch Runner, Menegotti, Morrison, Contec, Buddy, Crown, Edco, Wyco, Bomag, Laymor, EZ Trench, Bil-Jax, F.S. Curtis, Gehl Pavers, Heli, Honda, ICS/PowerGrit, IHI, Partner, Imer, Clipper, MMD, Koshin, Rice, CH&E, General Equipment, Amida, Coleman, NAC, Gradall, Square Shooter, Kent, Stanley, Tamco, Toku, Hatz, Kohler, Robin, Wisconsin, Northrock, Oztec, Toker TK, Rol-Air, APT, Wylie, Ingersoll Rand / Doosan, Innovatech, Con X, Ammann, Mecalac, Makinex, Smith Surface Prep, Small Line, Wanco, Yanmar