

PARTS MANUAL



**MODEL
WTB-16**

POWER BUGGY

(GX690 ELECTRIC START GASOLINE ENGINE)

Revision #11 (08/23/22)



THIS MANUAL MUST ACCOMPANY THE EQUIPMENT AT ALL TIMES.

PARTS FINDER

**Search Website
by Part Number**



**Search Manual
Library For Parts
Manual & Lookup Part
Numbers – Purchase
or Request Quote**

Search Manuals

Enter your information to help us find the right parts manual for your machine.

* Brand:

* Model:

* Serial:

* Part Number:

SEARCH

**Can't Find Part or
Manual? Request Help
by Manufacturer,
Model & Description**

Parts Order Form

Please fill in the following information to help us find the right part for your machine.

Manufacturer:	<input type="text"/>
Model:	<input type="text"/>
Description:	<input type="text"/>
Part Number:	<input type="text"/>
Quantity:	<input type="text"/>
Notes:	<input type="text"/>

SEARCH

Discount-Equipment.com is your online resource for quality parts & equipment.

Florida: **561-964-4949** Outside Florida TOLL FREE: **877-690-3101**

Need parts?

Click on this link: <http://www.discount-equipment.com/category/5443-parts/> and choose one of the options to help get the right parts and equipment you are looking for. Please have the machine model and serial number available in order to help us get you the correct parts. If you don't find the part on the website or on one of the online manuals, please fill out the request form and one of our experienced staff members will get back to you with a quote for the right part that your machine needs.

We sell worldwide for the brands: Genie, Terex, JLG, MultiQuip, Mikasa, Essick, Whiteman, Mayco, Toro Stone, Diamond Products, Generac Magnum, Airman, Haulotte, Barreto, Power Blanket, Nifty Lift, Atlas Copco, Chicago Pneumatic, Allmand, Miller Curber, Skyjack, Lull, Skytrak, Tsurumi, Husquvarna Target, Stow, Wacker, Sakai, Mi-T-M, Sullair, Basic, Dynapac, MBW, Weber, Bartell, Bennar Newman, Haulotte, Ditch Runner, Menegotti, Morrison, Contec, Buddy, Crown, Edco, Wyco, Bomag, Laymor, EZ Trench, Bil-Jax, F.S. Curtis, Gehl Pavers, Heli, Honda, ICS/PowerGrit, IHI, Partner, Imer, Clipper, MMD, Koshin, Rice, CH&E, General Equipment, Amida, Coleman, NAC, Gradall, Square Shooter, Kent, Stanley, Tamco, Toku, Hatz, Kohler, Robin, Wisconsin, Northrock, Oztec, Toker TK, Rol-Air, APT, Wylie, Ingersoll Rand / Doosan, Innovatech, Con X, Ammann, Mecalac, Makinex, Smith Surface Prep, Small Line, Wanco, Yanmar

TABLE OF CONTENTS

WTB-16 POWER BUGGY

Explanation Of Code In Remarks Column.....	4
Suggested Spare Parts	5

Component Drawings

Nameplate And Decals Assembly	6-7
Platform Assembly.....	8-9
Cap Filler Breather Assembly.....	10-11
Rubber Track/Roller Wheel Assembly.....	12-13
Sprocket/Roller Wheel Assembly	14-15
Dump Pedal/Valve Assembly.....	16-17
Tub Assembly	18-19
Steering Assembly.....	20-21
Pump Control Rods Assembly.....	22-23
Control Rods Steering Levers Assembly	24-25
Hydraulic Drive Motor Assembly	26-27
Dump Valve Assembly	28-29
Hydraulic Oil Cooler Assembly	30-31
Electronic Components Assembly.....	32-33
Engine Mounting/Muffler Assembly	34-35
Fuel Tank Assembly.....	36-37
Fuel Tank Enclosure Assembly.....	38-39
Panels Assembly	40-41
Engine Service Parts.....	42-43

NOTICE

Specifications and part numbers are subject to change without notice.

EXPLANATION OF CODE IN REMARKS COLUMN

The following section explains the different symbols and remarks used in the Parts section of this manual. Use the help numbers found on the back page of the manual if there are any questions.

NOTICE

The contents and part numbers listed in the parts section are subject to change **without notice**. Multiquip does not guarantee the availability of the parts listed.

SAMPLE PARTS LIST

NO.	PART NO.	PART NAME	QTY.	REMARKS
1	12345	BOLT	1	INCLUDES ITEMS W/%
2%		WASHER, 1/4 IN.		NOT SOLD SEPARATELY
2%	12347	WASHER, 3/8 IN. ...	1	MQ-45T ONLY
3	12348	HOSE	A/R	MAKE LOCALLY
4	12349	BEARING	1	S/N 2345B AND ABOVE

NO. Column

Unique Symbols — All items with same unique symbol (@, #, +, %, or >) in the number column belong to the same assembly or kit, which is indicated by a note in the “Remarks” column.

Duplicate Item Numbers — Duplicate numbers indicate multiple part numbers, which are in effect for the same general item, such as different size saw blade guards in use or a part that has been updated on newer versions of the same machine.

NOTICE

When ordering a part that has more than one item number listed, check the remarks column for help in determining the proper part to order.

PART NO. Column

Numbers Used — Part numbers can be indicated by a number, a blank entry, or TBD.

TBD (To Be Determined) is generally used to show a part that has not been assigned a formal part number at the time of publication.

A blank entry generally indicates that the item is not sold separately or is not sold by Multiquip. Other entries will be clarified in the “Remarks” Column.

QTY. Column

Numbers Used — Item quantity can be indicated by a number, a blank entry, or A/R.

A/R (As Required) is generally used for hoses or other parts that are sold in bulk and cut to length.

A blank entry generally indicates that the item is not sold separately. Other entries will be clarified in the “Remarks” Column.

REMARKS Column

Some of the most common notes found in the “Remarks” Column are listed below. Other additional notes needed to describe the item can also be shown.

Assembly/Kit — All items on the parts list with the same unique symbol will be included when this item is purchased.

Indicated by:

“INCLUDES ITEMS W/(unique symbol)”

Serial Number Break — Used to list an effective serial number range where a particular part is used.

Indicated by:

“S/N XXXXX AND BELOW”

“S/N XXXX AND ABOVE”

“S/N XXXX TO S/N XXX”

Specific Model Number Use — Indicates that the part is used only with the specific model number or model number variant listed. It can also be used to show a part is NOT used on a specific model or model number variant.

Indicated by:

“XXXXX ONLY”

“NOT USED ON XXXX”

“Make/Obtain Locally” — Indicates that the part can be purchased at any hardware shop or made out of available items. Examples include battery cables, shims, and certain washers and nuts.

“Not Sold Separately” — Indicates that an item cannot be purchased as a separate item and is either part of an assembly/kit that can be purchased, or is not available for sale through Multiquip.

SUGGESTED SPARE PARTS

WBT-16 POWER BUGGY

1 to 3 units

Qty.	P/N	Description
2	805929	TRACK, RUBBER
2	807605	FILTER, HYDRAULIC OIL
1	3353	CAP, HYDRAULIC OIL TANK
1	806947	CAP, FUEL
1	519795	SWITCH, EMERG. STOP
1	518767	SWITCH, PARK BRAKE

NOTICE

Part numbers on this Suggested Spare Parts list may supersede/replace the part numbers shown in the following parts lists.

ENGINE HONDA GX690RHKXA (ELECTRIC START)

1 to 3 units

Qty.	P/N	Description
2	980795587G	SPARK PLUG
3	17210z6I010	AIR FILTER, ELEM. (DUAL)
3	17218Z6L000	AIR FILTER, OUTER
3	16910Z6L003	FILTER, IN-LINE FUEL
2	15400RTA003	CARTRIDGE, OIL FILTER
2	35110ZV5V50	IGNITION KEY SET

NAMEPLATE AND DECALS ASSY.

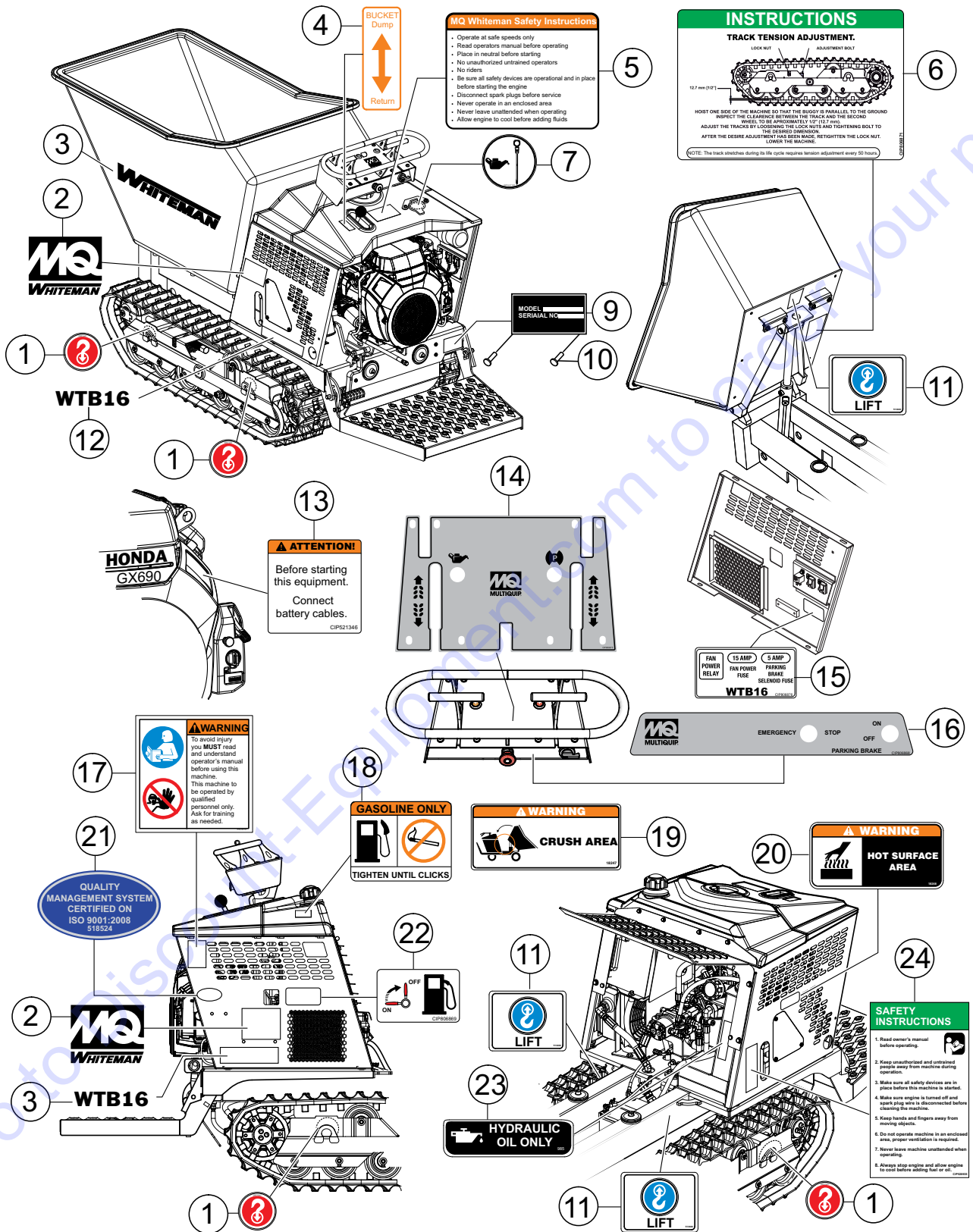

NAMEPLATE AND DECALS ASSY.

<u>NO.</u>	<u>PART NO.</u>	<u>PART NAME</u>	<u>QTY.</u>	<u>REMARKS</u>
1	513393	DECAL, TIE-DOWN POINT	4	
2	18252	DECAL, MQ WHITEMAN	2	
3		DECAL, WHITEMAN LOGO	1	MOLDED INTO TUB
4		DECAL, BUCKET DUMP LEVER	1	MOLDED INTO FUEL TANK COVER
5		DECAL, WHITEMAN SAFETY INSTRUCTIONS	1	MOLDED INTO FUEL TANK COVER
6	806871	DECAL, INSTRUCTIONS, TRACK TENSION	1	
7	807137	DECAL, DECAL, OIL LEVEL	1	
9		PLATE, SERIAL NUMBER.....	1	CONTACT DISCOUNT-EQUIPMENT
10	491757	RIVET, I.D. PLATE	2	
11	513608	DECAL, LIFTING HOOK	3	
12	806874	DECAL, WTB16	2	
13	521346	DECAL, WARNING CONNECT BATT. CABLES	1	
14	806875	DECAL, OVERLAY, STEERING	1	
15	806876	DECAL, REALAY, FUSES	1	
16	806868	DECAL, OVERLAY, EMERG. STP./PARK BRAKE	1	
17	35137	DECAL, READ MANUAL, ASK FOR TRAINING	1	
18		DECAL, GASOLINE ONLY	1	MOLDED INTO FUEL TANK COVER
19	18247	DECAL, CRUSH WARNING	1	
20	18248	DECAL, HOT SURFACE WARNING	1	
21	518524	DECAL, ISO 9001:2008	1	
22	806869	DECAL, FUEL VALVE LEVER, ON/OFF	1	
23	EM985	DECAL, HYDRAULIC OIL	1	
24	520935	DECAL, SAFETY INSTRUCTIONS	1	

PLATFORM ASSY.

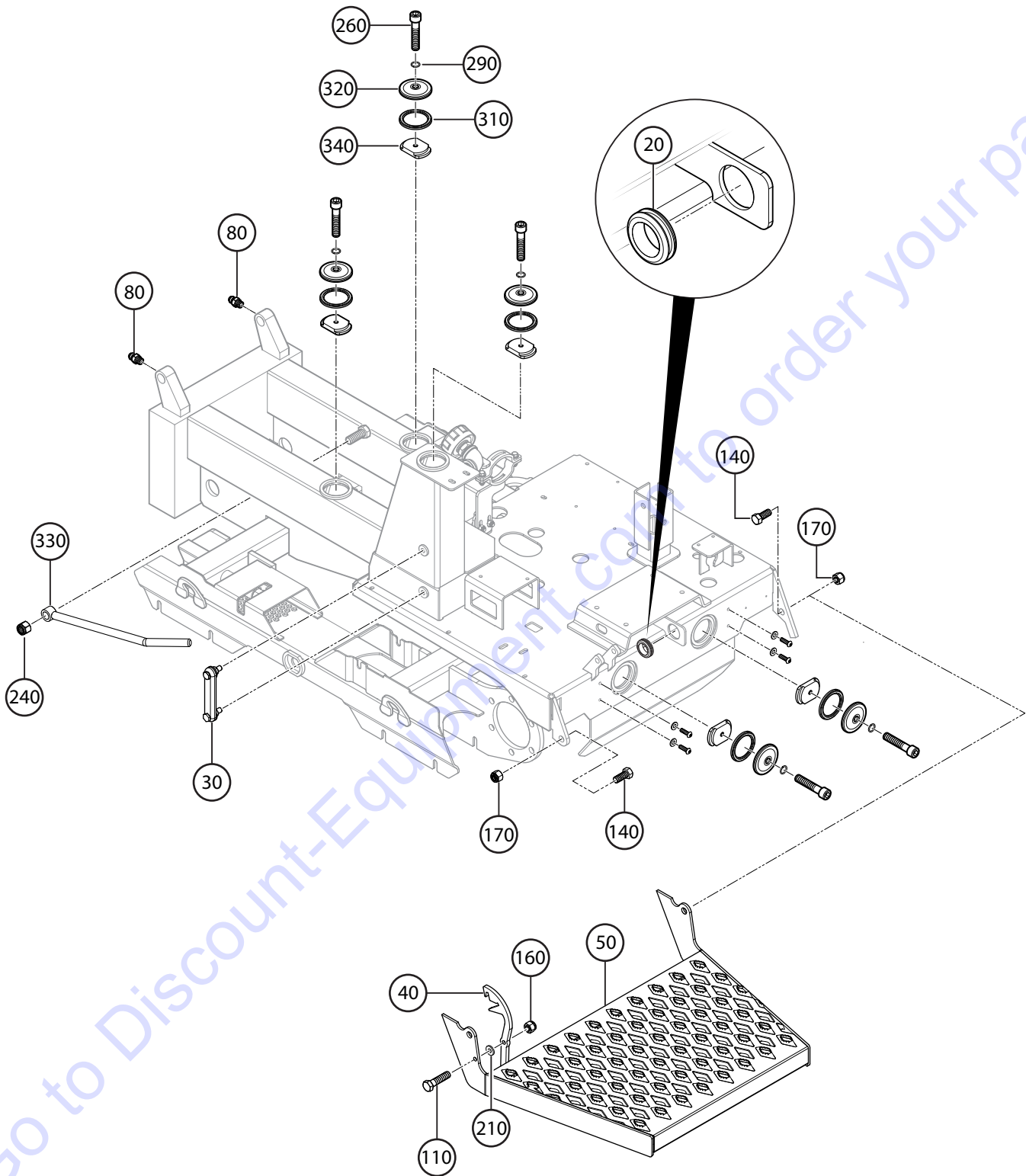

PLATFORM ASSY.

<u>NO.</u>	<u>PART NO.</u>	<u>PART NAME</u>	<u>QTY.</u>	<u>REMARKS</u>
20	13212	GROMMET, 1-1/4" ID	1	
30	18052	SIGHT GAUGE	1	
40	18173	LATCH PLATFORM	1	
50	18222	PLATFORM OPERATOR	1	
80	EM916019	FITTING, GREASE.....	2.....	REPLACES P/N 491705
110	EM963057	BOLT, 3/8" DIA.	1.....	REPLACES P/N 492313
140	492406	BOLT, GD 8	2	
160	EM969013	NUT, NYLON 3/8" NC NYLON G8.....	5.....	REPLACES P/N 492583
170	EM969023	NUT, LOCK 5/8" NC NYLON G8.....	2.....	REPLACES P/N 492586
210	3019092	WASHER, FLAT 3/8".....	1.....	REPLACES P/N 492598
240	505069	NUT, 3/4" NC NYLON GRD. 8	1	
260	505990	BOLT 1/2" X 2-1/2"	5	
290	520343	O-RING	5	
310	806327	RUBBER SEAL, COVER	5	
320	806328	COVER, RESERVOIR	5	
330	806453	TUB, SUPPORT ROD	1	
340	806523	RETAINER/COVER	5	

CAP FILLER BREATHER ASSY.

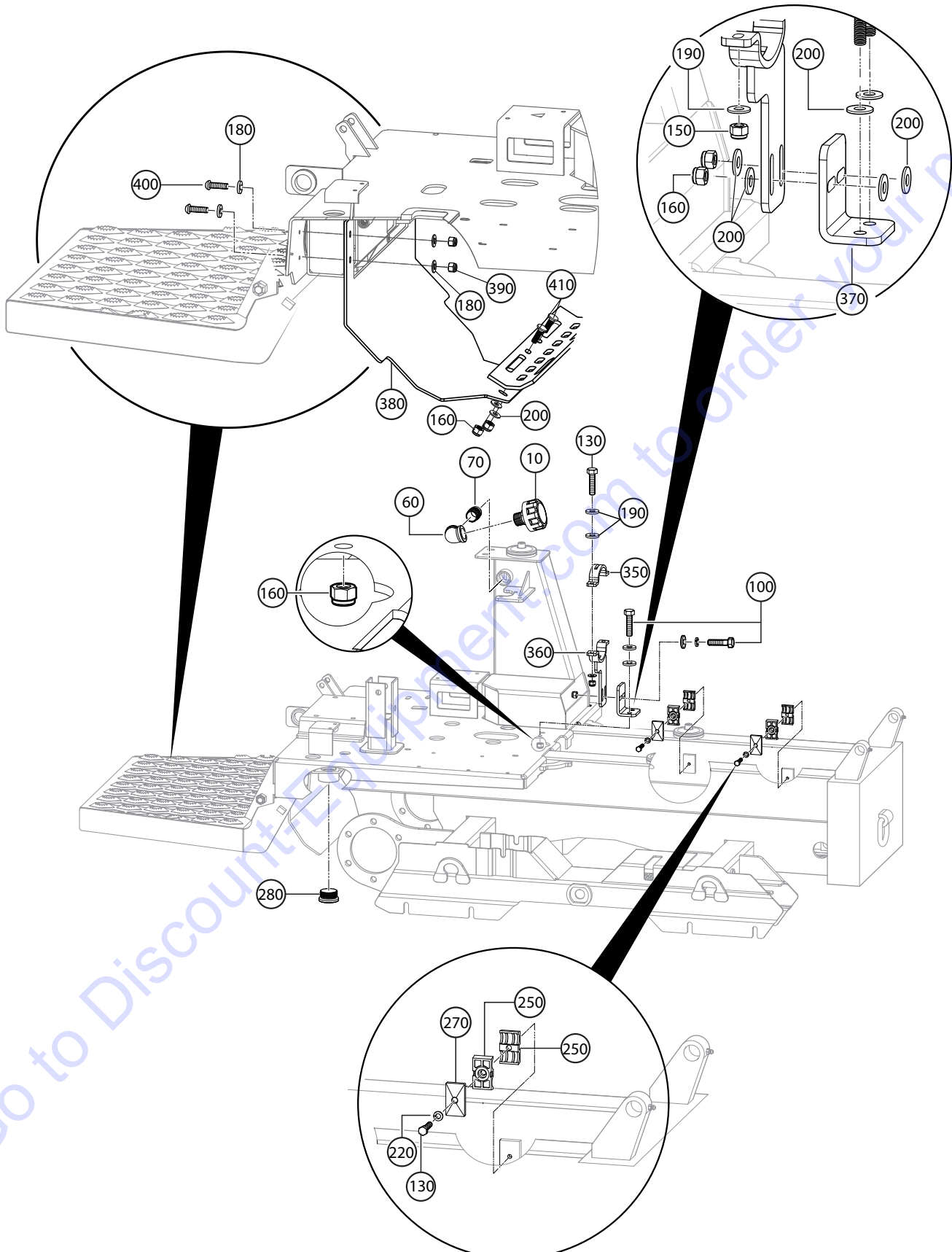

CAP FILLER BREATHER ASSY.

<u>NO.</u>	<u>PART NO.</u>	<u>PART NAME</u>	<u>QTY.</u>	<u>REMARKS</u>
10	3353	CAP, FILLER/BREATHER	1	
60	491160	90° ELBOW 1"	1	
70	491189	NIPPLE 1" NPT C/C GALV.	1	
100	492312	BOLT, 3/8"NC X 1-1/4" G2	4	
130	492366	SCREW HHC 5/16-18" X 1-1/2"	4	
150	2105164	NUT, NYLON 5/16-18"	2	REPLACES P/N 492582
160	EM969013	NUT, NYLON 3/8" NC NYLON G8.....	7	REPLACES P/N 492583
180	492595	WASHER, FLAT 1/4"	8	
190	EM923057	WASHER, FLAT 1/4".....	6	REPLACES P/N 492596
200	492597	WASHER, FLAT 3/8"	8	
220	EM923343	WASHER, LOCK 5/16"	2	REPLACES P/N 492623
250	505976	CLAMP (SET OF TWO PIECES)	4	
270	506185	PLATE CORNER	2	
280	519875	PLUG	1	
350	806542	CLAMP, PUMP SUPPORT, TOP	1	
360	806543	CLAMP, PUMP SUPPORT, BOTTOM	1	
370	806544	SUPPORT BRACKET, PUMP	1	
380	806796	COVER, HYDRAULIC HOSES	1	
390	100078	NUT, M6 NYLOC GRD. 8.8	4	
400	100443	BOLT, M6" X 20"	4	
410	513452	SCREW 3/8 X 1-1/4" NC	2	

RUBBER TRACK/ROLLER WHEEL ASSY.

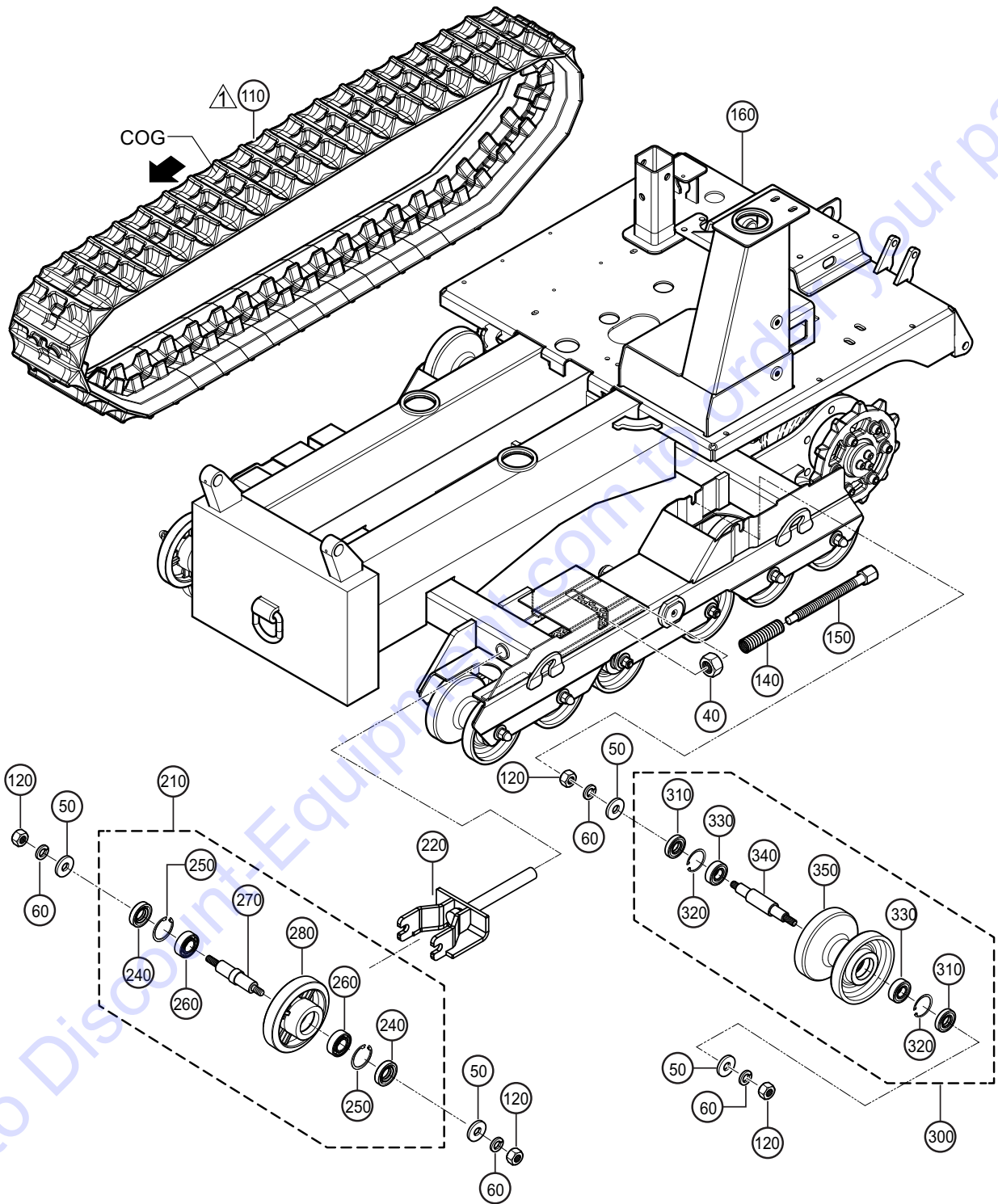

NOTE:
▲ WHEN INSTALLING RUBBER TRACK
ORIENTATE COGS AS SHOWN.

RUBBER TRACK/ROLLER WHEEL ASSY.

<u>NO.</u>	<u>PART NO.</u>	<u>PART NAME</u>	<u>QTY.</u>	<u>REMARKS</u>
40	492558	JAM NUT 3/4" DIA.	2	
50	506109	WASHER, FLAT 5/8"	24	
60	492627	WASHER, LOCK 5/8" DIA.	24	
110	805929	TRACK, RUBBER	2	
120	492557	NUT, 5/8" HEX NC GRD. 5	24	
140	806016	SLEEVE, ADJUSTMENT BOLT	2	
150	806022	ADJUSTMENT BOLT	2	
160	806147	CHASSIS, FRAME	1	
210	806219	DRIVEN TENSIONER, WHEEL ASSY.....	2	INCLUDES ITEMS W/\$
220	806220	DRIVEN WHEEL BRACKET	2	
240\$	806011	OIL SEAL	2	
250\$	806014	SNAP RING	2	
260\$	806013	BEARING	2	
270\$	805910	SHAFT, DRIVEN WHEEL	1	
280\$	805905	DRIVEN WHEEL	1	
300	806218	ROLLER, WHEEL ASSY.....	14	INCLUDES ITEMS W/#
310#	806010	OIL SEAL	2	
320#	804288	SNAP RING	2	
330#	493296	BEARING	2	
340#	805911	SHAFT, GUIDE WHEEL	1	
350#	805816	GUIDE WHEEL	1	

SPROCKET/ROLLER WHEEL ASSY.

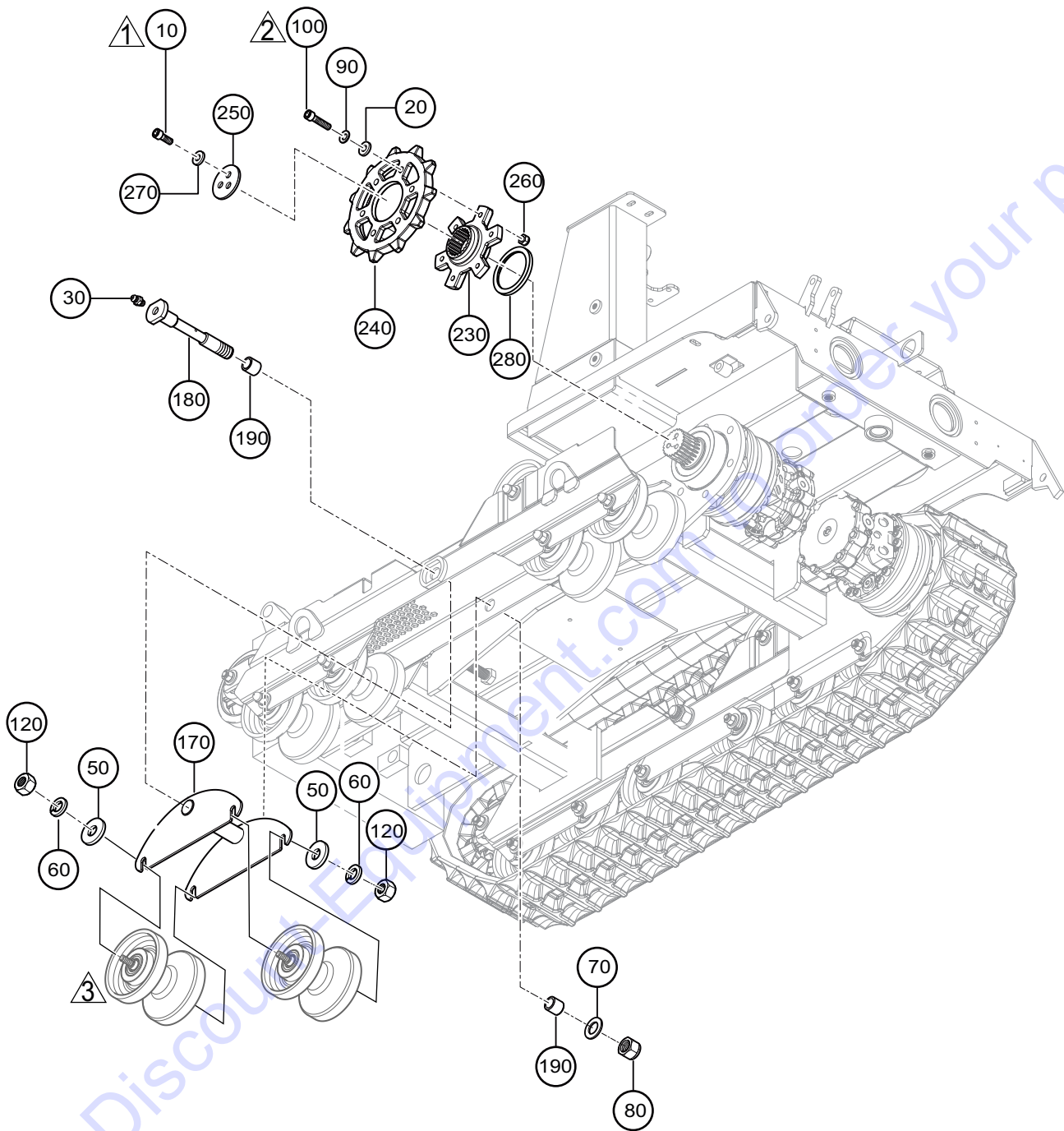

NOTE:

- ① TORQUE TO 61 LB-FT.
- ② TORQUE TO 89 LB-FT.
- ③ REFERENCE RUBBER TRACK/ROLLER WHEEL ASSY., ITEM 300

SPROCKET/ROLLER WHEEL ASSY.

<u>NO.</u>	<u>PART NO.</u>	<u>PART NAME</u>	<u>QTY.</u>	<u>REMARKS</u>
10	162	SCREW, M10 X 25	6	
20	EM621	WASHER, 1/2" SPECIAL	12	
30	EM916019	FITTING, GREASE	2	REPLACES P/N 491705
50	EM506109	WASHER, FLAT 5/8"	8	
60	EM923348	WASHER, LOCK 5/8" DIA.	8	
70	EM501299	WASHER, FLAT 1"	2	
80	511495	NUT, 1" NYLOC	2	
90	519337	WASHER, LOCK 1/2"	12	
100	801310	SCREW M12 X 50	12	
120	EM968013	NUT, HEX. 5/8 "NC GRD. 5	8	
170	806167	BRACKET, SWIVEL WHEELS	2	
180	806168	SHAFT, SWIVEL WHEELS	2	
190	806169	SPACER	4	
230	806443M	SPROCKET, INNER	2	
240	806444TT	SPROCKET, OUTER	2	
250	806878	COVER, HYDRAULIC MOTOR	2	
260	100081	NUT, M12	12	
270	100518	WASHER, FLAT M10	6	
280	807093	SPACER, SPROCKET	2	

DUMP PEDAL/VALVE ASSY.

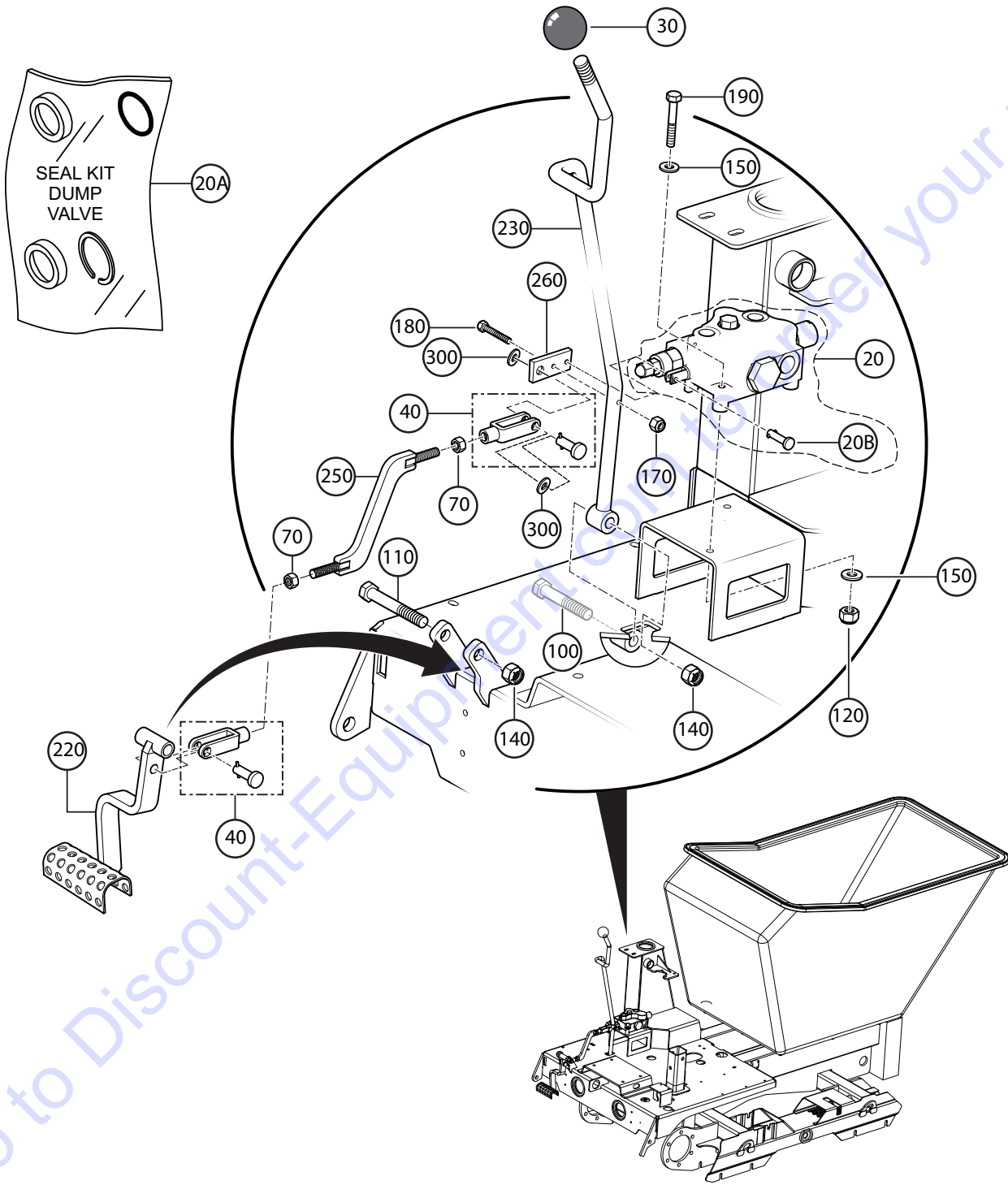

DUMP PEDAL/VALVE ASSY.

<u>NO.</u>	<u>PART NO.</u>	<u>PART NAME</u>	<u>QTY.</u>	<u>REMARKS</u>
20	18064	VALVE, DUMP	1.....	INCLUDES ITEM W/\$
20A	18064SK	SEAL KIT, DUMP VALVE	1	
20B\$		PIN, DUMP VALVE CROSS.....	1.....	NOT SOLD SEPARATELY
30	18121	KNOB, LEVER	1	
40	18123	CLEVIS ASSY., DUMP VALVE	2	
70	490172	NUT, 3/8"NF HEX. GRD. 5	2	
100	505718	SCREW, HHC 1/2-13" X 2-3/4" NC GRD. 5	1	
110	3215	SCREW, HHC 1/2"-13 X 3-1/2".....	1.....	REPLACES P/N 492400
120	492581	NUT, NYLOC 1/4"-20	2	
140	492584	NUT, NYLOC 1/2" DIA. NC	2	
150	492595	WASHER, FLAT 1/4"	4	
170	503119	NUT, NYLOC 3/16" NYLON G8	1	
180	512183	SCREW, HHC 10-24 X 1-1/4"	1	
190	506088	SCREW, HHC 1/4-20 X 3/8"	2	
220	806211	PEDAL, DUMP VALVE	1	
230	806212	LEVER, DUMP VALVE	1	
250	806538	ROD, DUMP VALVE	1	
260	806553	BELL CRANK, DUMP VALVE PLATE	1	
300	492598	WASHER, FLAT 3/8"	2	

TUB ASSY.

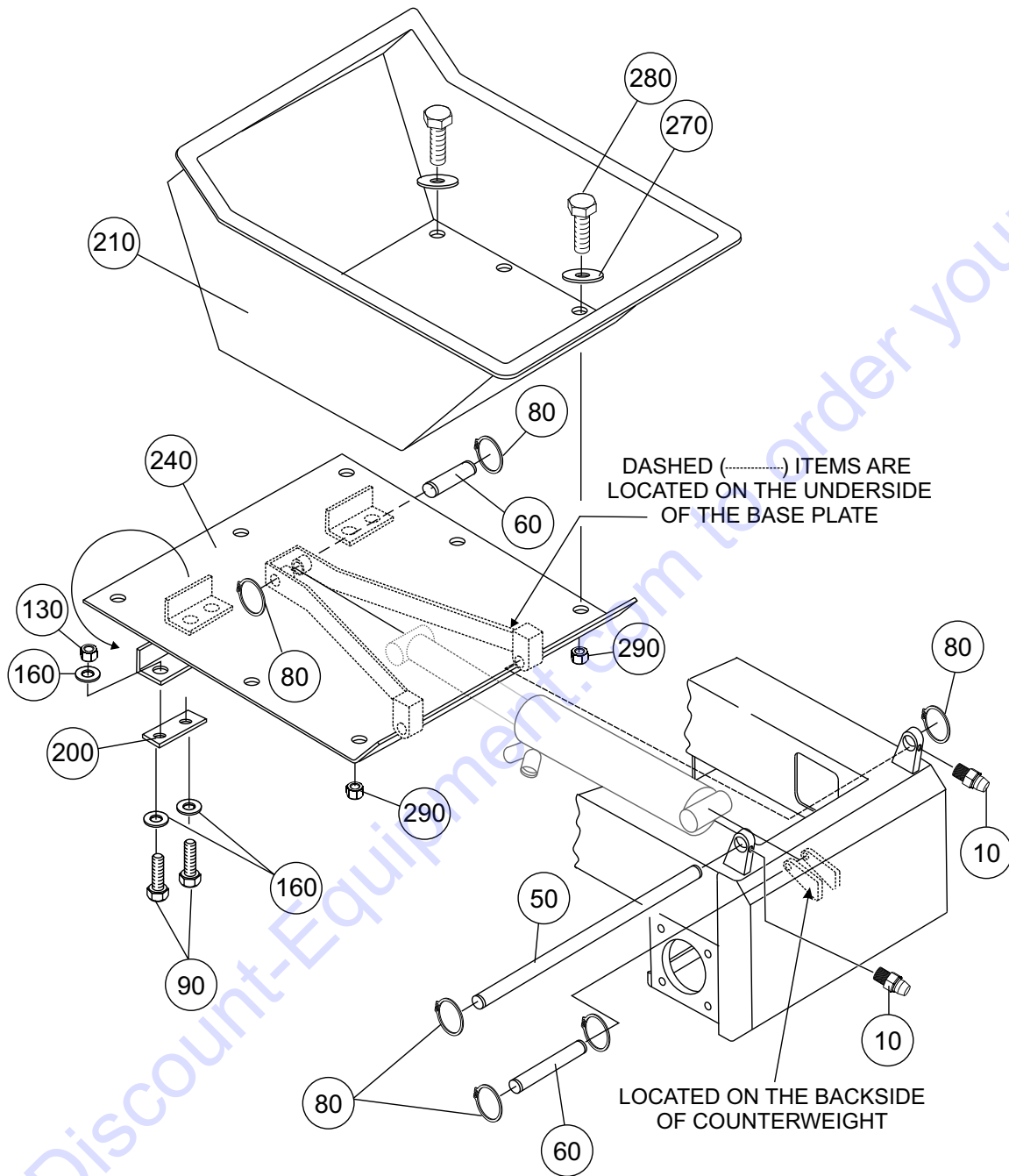

TUB ASSY.

<u>NO.</u>	<u>PART NO.</u>	<u>PART NAME</u>	<u>QTY.</u>	<u>REMARKS</u>
10	EM916019	GREASE FITTING.....	2.....	REPLACES P/N 491705
50	18129	PIN, TUB FRAME CROSS	1	
60	18130	PIN, HOPPER DUMP CYLINDER	2	
80	JISB2804C25	RING RETAINING.....	6.....	REPLACES P/N 490957
90	492303	BOLT 5/16"-18 X 1-1/4" GRD. 5	4	REPLACES P/N 492365
130	2105164	NUT, NYLOC 5/16"-18.....	4.....	REPLACES P/N 492582
160	EM923057	WASHER, FLAT 1/4".....	8.....	REPLACES P/N 492596
200	512279	SUPPORT BUMPER STOP	2	
210	808271	TUB, PLASTIC, 15 CU. FT.	1	
240	806452	FRAME, TUB MOUNT, 16 CU. FT.....	1.....	BEFORE JULY 2020
240	502263	FRAME, TUB MOUNT, 16 CU. FT.....	1.....	EFFECTIVE JULY 2020
270	512193	WASHER, FLAT 3/8" LARGE	9	
280	EM963057	BOLT, 3/8" X 1-1/2" GRD. 5.....	9.....	REPLACES P/N 492313
290	EM969013	NUT, 3/8"NC NYLOC GRD. 8.....	9.....	REPLACES P/N 492583

STEERING ASSY.

<u>NO.</u>	<u>PART NO.</u>	<u>PART NAME</u>	<u>QTY.</u>	<u>REMARKS</u>
40	492401	BOLT, 1/2" DIA. X 4" NC GRD 5	2	
60	2105164	NUT, NYLOC 5/16"-18	8.....	REPLACES P/N 492582
80	492584	NUT, NYLOC 1/2"-13	2	
90	504723	NUT, 1/2" NC GRD 8	4	
120	492599	WASHER, FLAT 1/2"	2	
130	EM923057	WASHER, FLAT 1/4"	8	
150	492589	NUT, HEX 1/2" NF GRD. 5	4.....	REPLACES P/N 507661
160	521542	SCREW, 5/16" X 3/4" NC GRD. 5	8	
170	806562	HANDLE PLATFORM	1	
180	806595	MAIN SUPPORT, CONTROLS	1	
220	806614	STEERING LEVER, LEFT	1	
230	806615	STEERING LEVER, RIGHT	1	

Go to Discount-Equipment.com to order your parts

PUMP CONTROL RODS ASSY.

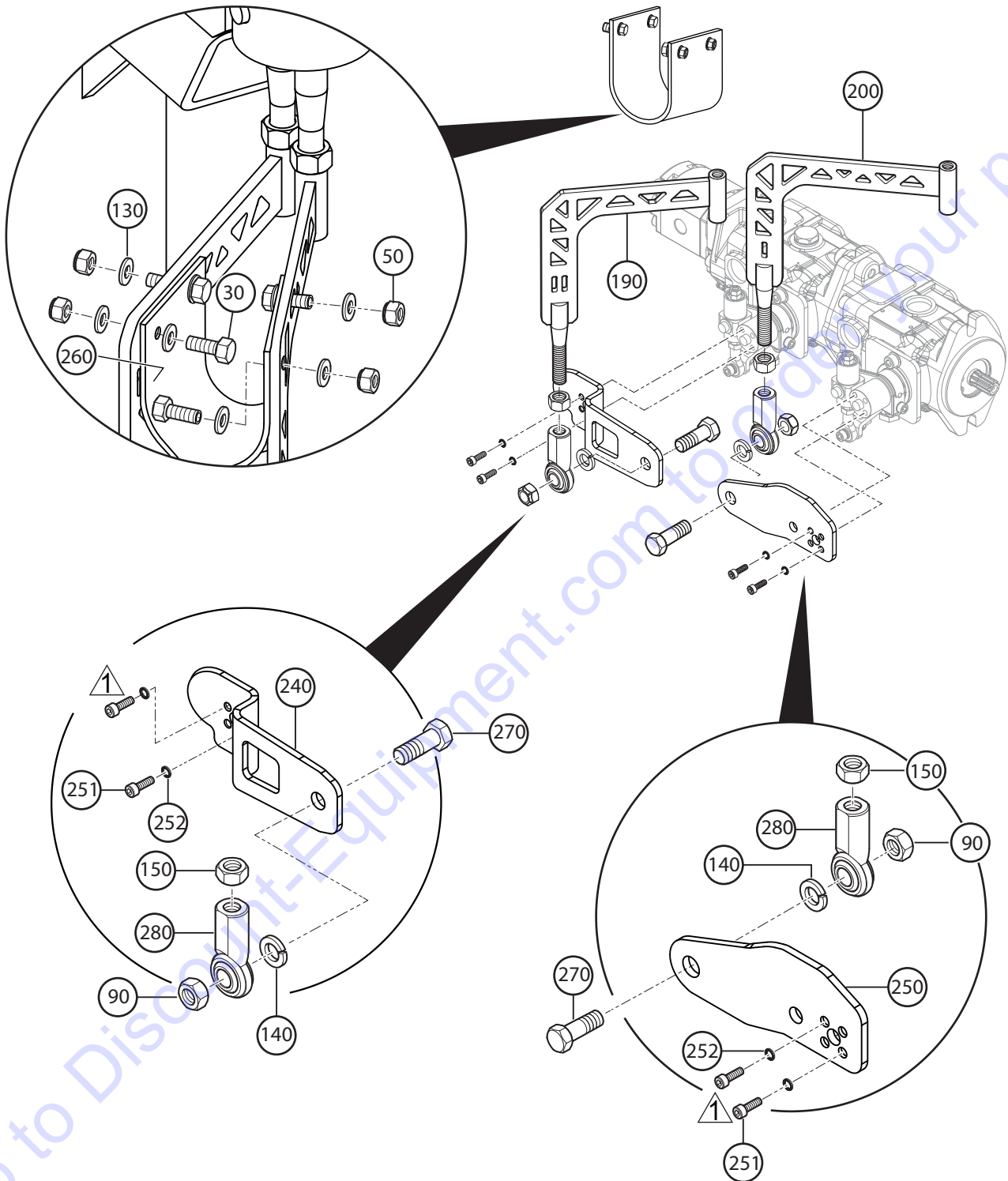

NOTE:

 TORQUE TO 13 LB-FT.

PUMP CONTROL RODS ASSY.

<u>NO.</u>	<u>PART NO.</u>	<u>PART NAME</u>	<u>QTY.</u>	<u>REMARKS</u>
30	492357	BOLT, 1/4" X 1 NC GRD 5	4	
50	492581	NUT, NYLOC 1/4"-20	4	
90	504723	NUT, 1/2" NC GRD 8	4	
130	492596	WASHER, FLAT 5/16"	8	
140	6109180	WASHER, LOCK 1/2" DIA.	2	REPLACES P/N 492626
150	492589	NUT, HEX 1/2" NF.....	4	REPLACES P/N 507661
190	806601	90° CONTROL ROD, RIGHT	1	
200	806605	90° CONTROL ROD, LEFT	1	
240	807360	LEVER, PUMP 2	1	
250	807359	LEVER, PUMP 1	1	
251	807654J	ALLEN HEAD BOLT M16X16 G12.9	16	
252	807655J	WAVE WASHER #10-6.401MM	16	
260	806798	RUBBER CONTROL ROD DAMPNER	1	
270	806852	SCREW, SPECIAL 1/2" X 1-1/2" NC	4	
280	806853	ROD, END 1/2" NF	2	

Go to Discount-Equipment.com to order your parts

CONTROL RODS STEERING LEVERS ASSY.

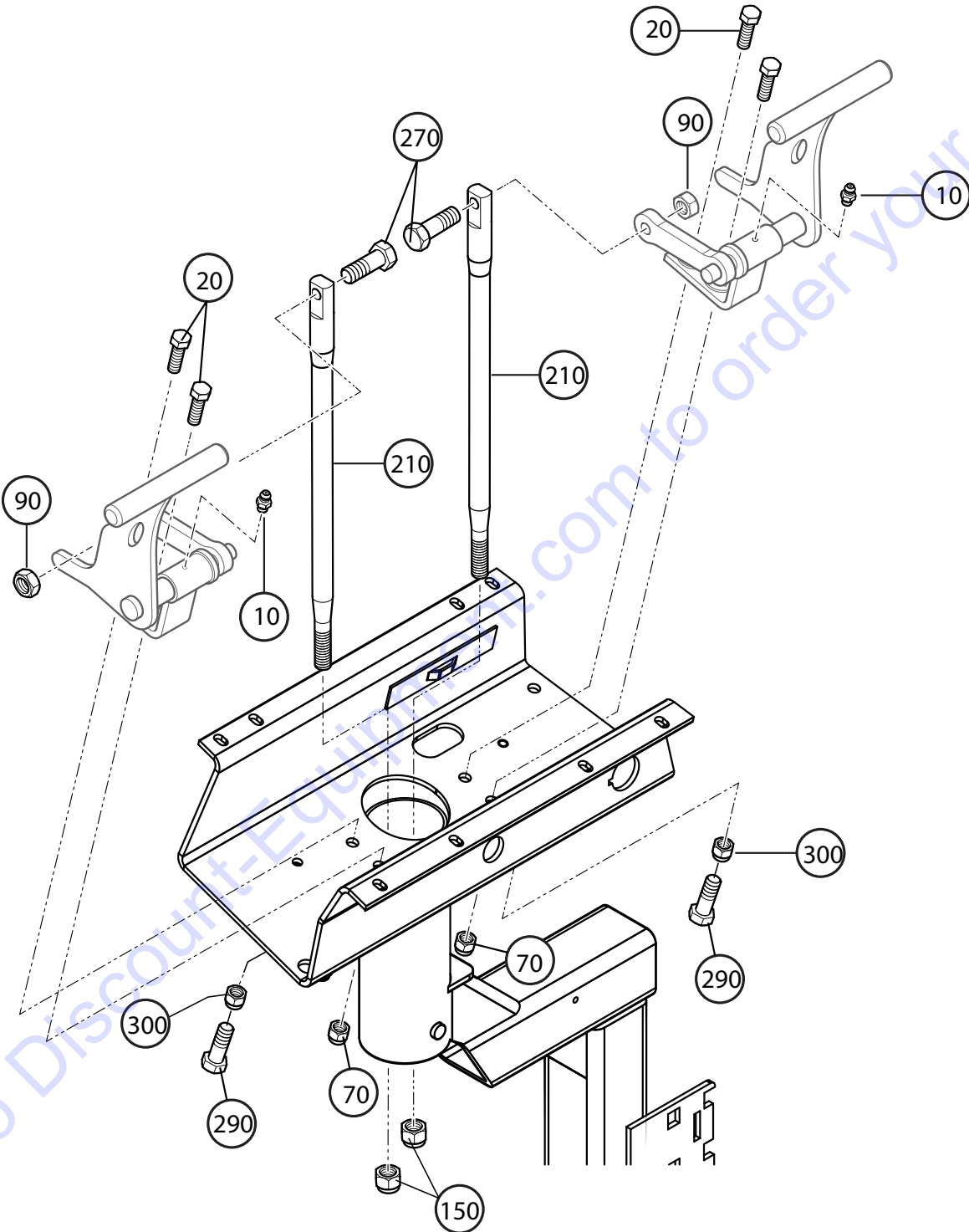

CONTROL RODS STEERING LEVERS ASSY.

<u>NO.</u>	<u>PART NO.</u>	<u>PART NAME</u>	<u>QTY.</u>	<u>REMARKS</u>
10	EM916019	FITTING, GREASE	2.....	REPLACES P/N 491705
20	492313	BOLT, 3/8" X 1-1/2" NC GRD 5	4	
70	EM969013	NUT, NYLOC 3/8"	4.....	REPLACES P/N 492583
90	504723	NUT, 1/2" DIA.	4	
150	492589	NUT, HEX 1/2" NF.....	4.....	REPLACES P/N 507661
210	806607	CONTROL RODS, STEERING LEVERS	2	
270	806852	SCREW, SPECIAL 1/2" X 1-1/2" NC	4	
290	492365	BOLT 5/16" 1X1-1/4" GRD. 5	2	
300	492541	NUT, HEX 5/16" NC GRD. 2	2	

Go to Discount-Equipment.com to order your parts

HYDRAULIC DRIVE MOTOR ASSY.

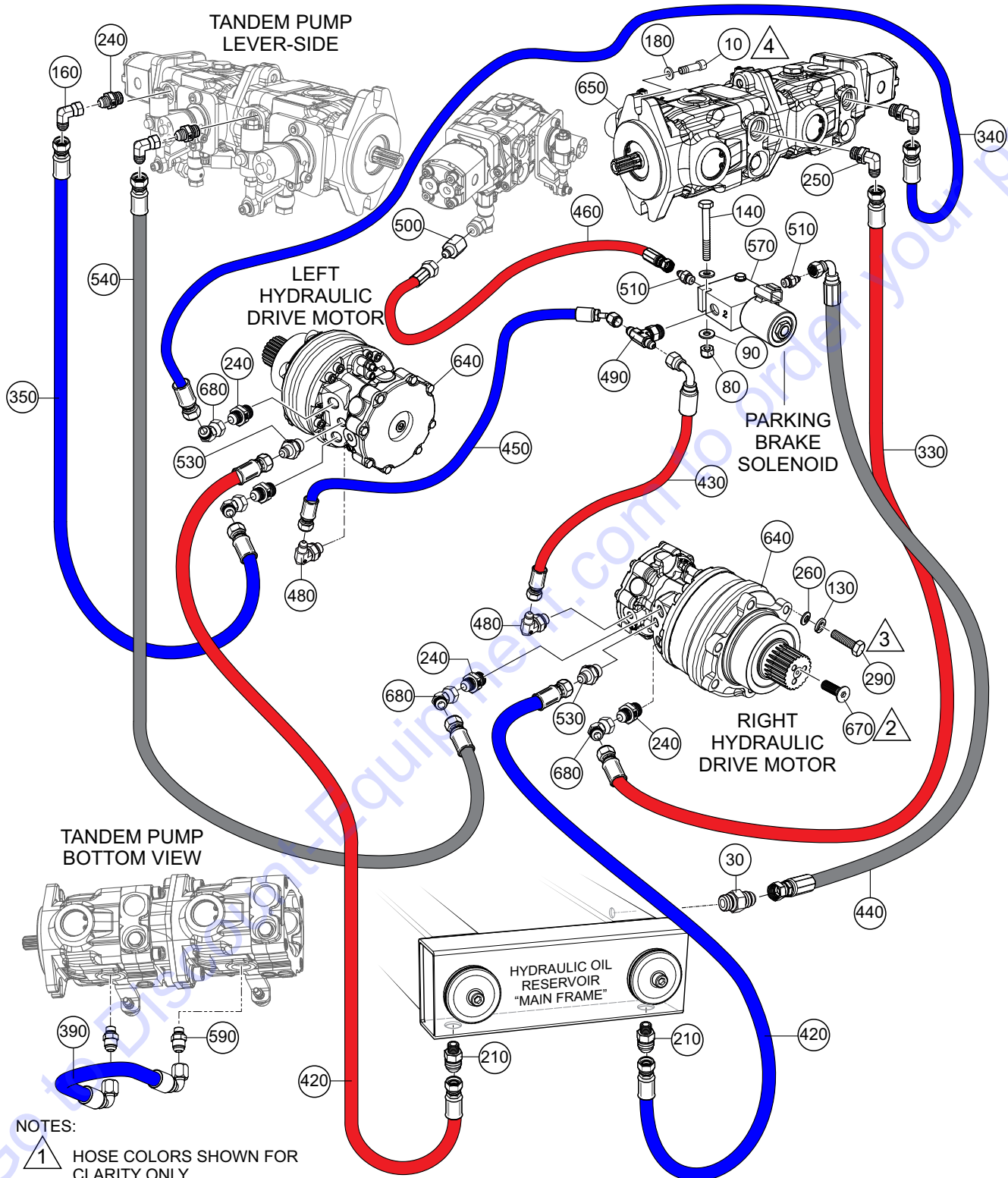

NOTES:

- 1 HOSE COLORS SHOWN FOR CLARITY ONLY.
- 2 TORQUE TO 150 LB-FT
- 3 TORQUE TO 218 LB-FT
- 4 TORQUE TO 20 LB-FT

HYDRAULIC DRIVE MOTOR ASSY.

<u>NO.</u>	<u>PART NO.</u>	<u>PART NAME</u>	<u>QTY.</u>	<u>REMARKS</u>
10	EM175	SCREW, 3/8"X 1-1/4" NC G5	2	
30	EM25511	FITTING, STRAIGHT 4 F5OX-S	1	
80	492581	NUT, NYLOC 1/4"-20	4	
90	492595	WASHER, FLAT 1/4"	4	
130	EM923348	WASHER, LOCK 5/8".....	10.....	REPLACES P/N 492627
140	506088	SCREW, HHC 1/4"-20 X 3/8"	2	
160	506195	90° ELBOW, 8 C6X-S	2	
180	3019092	WASHER, FLAT 3/8".....	2.....	REPLACES P/N 508346
210	511808	STRAIGHT FITTING 6 F5OX-S	2	
240	518821	FITTING, STRAIGHT 8-8 F42EDMX-S	6	
250	518822	90° ELBOW 8-8 C4OMX-S	2	
260	506109	WASHER, LOCK 5/8"	10	
290	521537	SCREW, M16 X 60	10	
330	806053	HOSE, HYD., PUMP 1 TO DRIVE MOTOR	1	
340	806055	HOSE, HYD., PUMP 2 TO DRIVE MOTOR	1	
350	806056	HOSE, HYD., GEAR PUMP TO DRIVE MOTOR.....	1.....	S/N 190411 AND BELOW
350	807558	HOSE, HYD., GEAR PUMP TO DRIVE MOTOR (LONG).....	1.....	S/N 190412 AND ABOVE
390	806084	HOSE, HYD., PUMP PORTS T11-T12	1	
420	806087	HOSE, HYD., DRV. MTR. TO HYD. RESERVOIR	2	
430	806088	HOSE, HYD., PARK BRK. SOL. TO RT. DRIVE MOTOR	1	
440	806089	HOSE, HYD., PARKING BRK. SOL. TO HYD. RESERVOIR	1	
450	806090	HOSE, HYD., PARK. BRK. SOL. TO LFT. DRIVE MOTOR	1	
460	806091	HOSE, HYD., PARK. BRK. SOL. TO PUMP	1	
480	806095	90° ELBOW 4-4 C4OMXS	2	
490	806096	TEE FITTING 4-4-6 S5OX-S	1	
500	806097	ADAPTER, STRAIGHT 4-4G4MXS	1	
510	806098	ADAPTER, STRAIGHT 4-6F5OX-S	2	
530	806101	ADAPTER, STRAIGHT 6-6 F42EDMX-S	2	
540	806102	HOSE, HYD., PUMP 1 TO RIGHT DRIVE MOTOR	1	
570	806527	SOLENOID, BRAKE	1	
590	806547	STRAIGHT FITTING 10-6 F42EDMX-S	2	
640	806794	HYDRAULIC MOTOR	2	
650	807657	TANDEM HYDRAULIC PUMP	1	
670	806998	SCREW, M16 X 50	2	
680	506200	45° ELBOW 8 V6X-S	4	

DUMP VALVE ASSY.

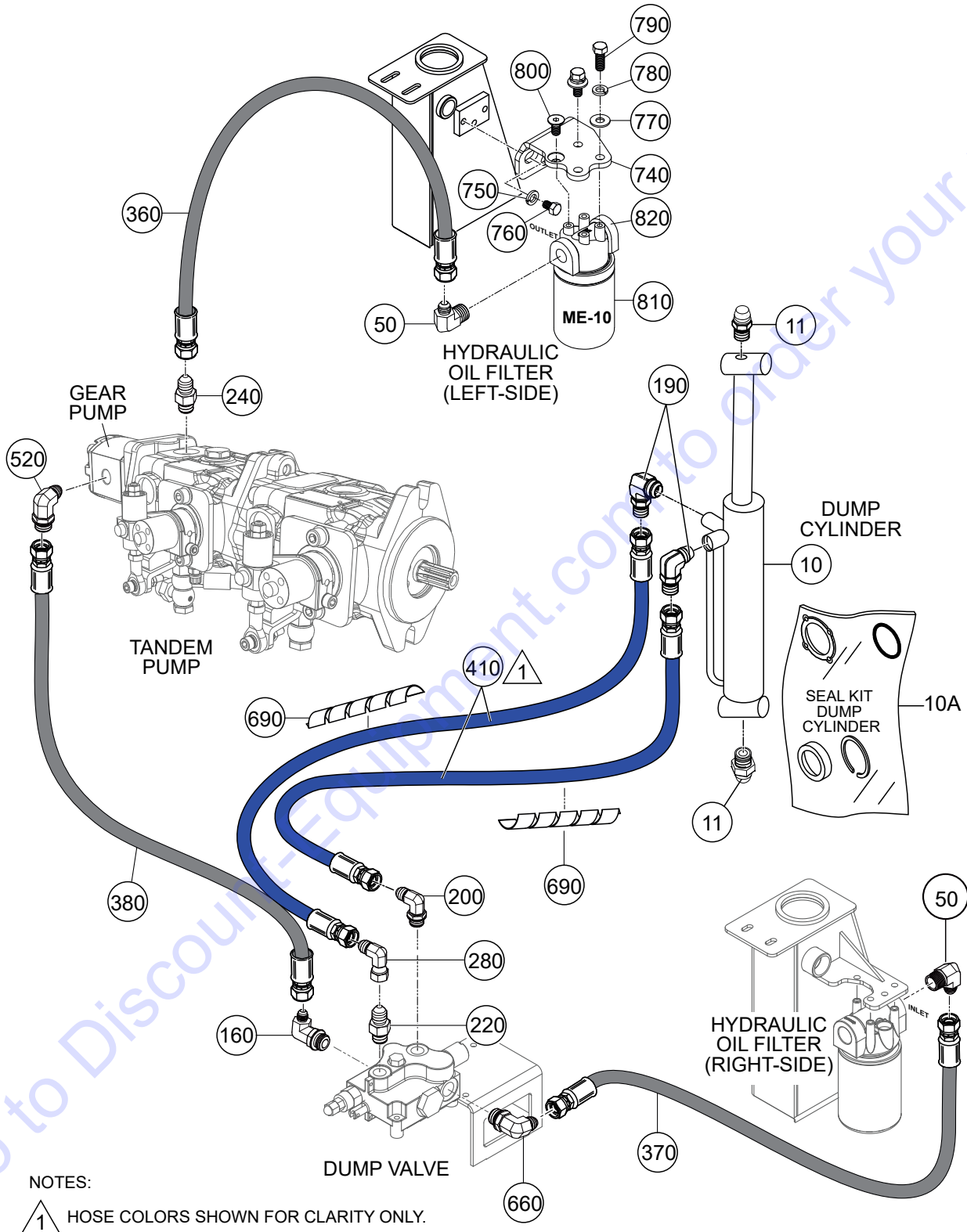

DUMP VALVE ASSY.

<u>NO.</u>	<u>PART NO.</u>	<u>PART NAME</u>	<u>QTY.</u>	<u>REMARKS</u>
10	18022	CYLINDER, HYDRAULIC	1	
10A	18022SK	SEAL KIT, DUMP CYLINDER	1	
11	491705	ZERK FITTING	2	
50	491375	90° ELBOW 8-12 CTX-S	2	
160	506195	90° ELBOW, 8 C6X-S	2	
190	511803	90° ELBOW 6-4 C5OX-S	2	
200	511804	90° ELBOW, 6-8 C5OX-S	1	
220	512190	FITTING, STRAIGHT 6-8 F5OX-S	1	
240	518821	FITTING, STRAIGHT 8-8 F42EDMX-S	1	
280	519967	90° ELBOW 6 C6X-S	1	
360	806057	HOSE, HYD., OIL FILTER (OUTLET) TO PUMP	1	
370	806058	HOSE, HYD., OIL FILTER (INLET) TO DUMP VALVE	1	
380	806083	HOSE, HYD., DUMP VALVE TO GEAR PUMP	1	
410	806086	HOSE, HYD., DUMP CYL. TO DUMP VALVE	2	
520	806100	90° ELBOW 6-6C4OMX-S	1	
660	EM16524	90° ELBOW 8-10 C5OX-S	1	
690	513614	SPRIAL VINYL, 12 IN. (304 MM)	1	1 PC = 1 FT.
740	807635	FILTER HEAD SUPPORT	1	
750	492626	LOCK WASHER 1/2" G. (CAD,2D)	3	
760	504456	HEX HEAD BOLT 1/2"NC X 3/4" G5	3	
770	492597	FLAT WASHER 3/8"	3	
780	492624	LOCK WASHER 3/8"	3	
790	492375	HEX HEAD BOLT 3/8"NC X 1" G5	3	
800	807641	FLAT HEAD BOLT 3/8" X 3/4" NC G5	1	
810	807605	FILTER, SPIN-ON, ZINGA ME-10	1	
820	807604	DHF SERIES SPIN-ON FILTER HEAD	1	

HYDRAULIC OIL COOLER ASSY.

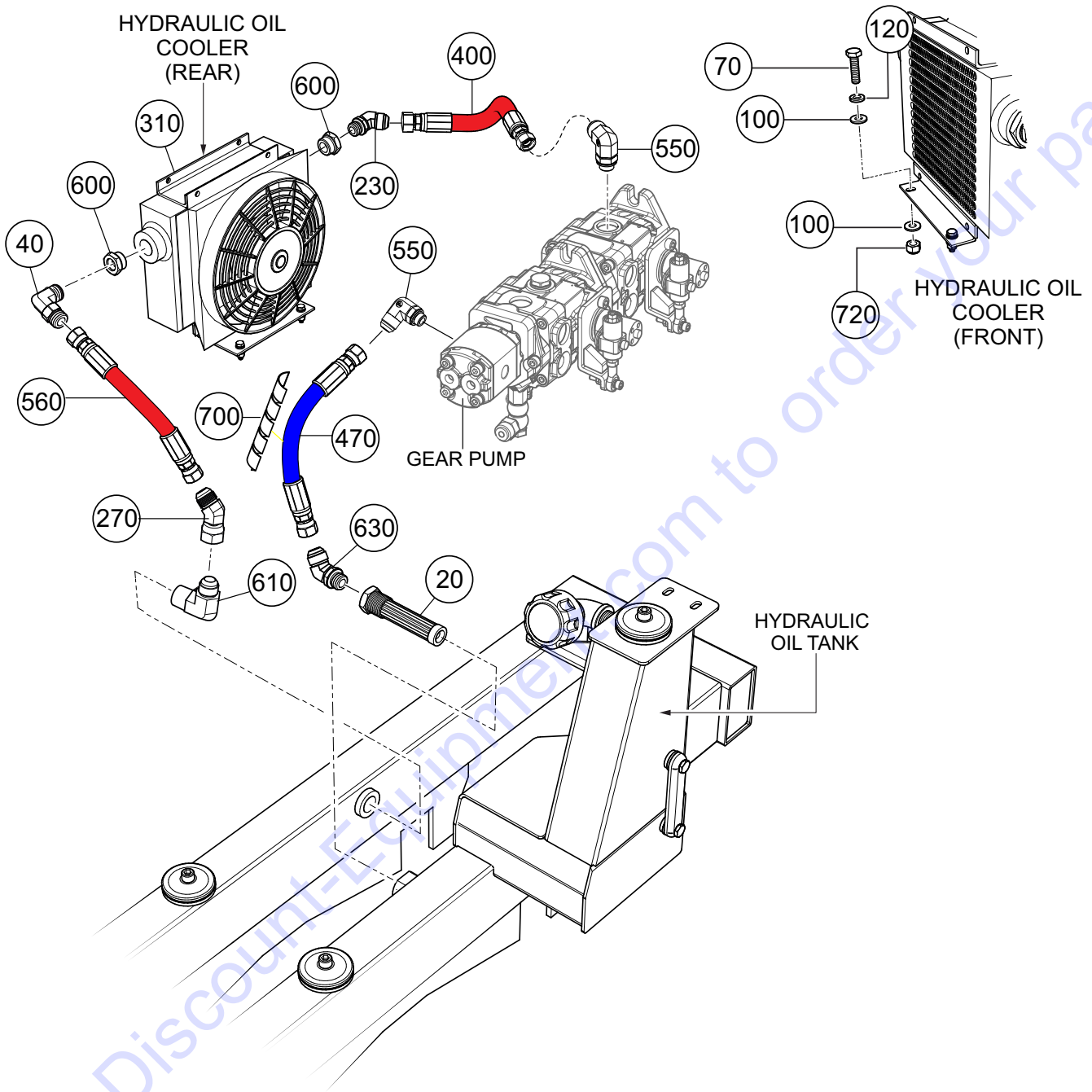

HYDRAULIC OIL COOLER ASSY.

<u>NO.</u>	<u>PART NO.</u>	<u>PART NAME</u>	<u>QTY.</u>	<u>REMARKS</u>
20	18229	STRAINER, SUCTION	1	
40	3322	90° ELBOW, 90 10MJ-10MO	1	
70	0202	SCREW HHC 5/16"X18X1.....	2	REPLACES P/N 492364
100	EM923057	WASHER, FLAT 1/4".....	4	REPLACES P/N 492596
120	EM923343	WASHER, LOCK 5/16".....	2	REPLACES P/N 492623
230	514230	45° ELBOW 10 V5OX-S	1	
250	518822	90° ELBOW 8-8 C4OMX-S	1	
270	519901	45° ELBOW 10 V6X-S	1	
310	802001	OIL COOLER	1	
400	806085	HOSE, HYD., PUMP TO OIL COOLER	1	
470	806092	HOSE, HYD., PUMP TO RESERVOIR (SUCTION)	1	
550	806467	90° ELBOW 10-6 C4OMX-S	1	
560	806468	HOSE, HYD., OIL COOLER TO RESERVOIR (RETURN)	1	
600	806548	ADAPTER 16-10F5OG5-S	2	
610	806549	90° ELBOW 10-12 CTX-S	1	
630	806552	45° ELBOW 12-8 VTX-S	1	
700	513614	SPRIAL VINYL, 8 IN. (203 MM).....	1	1 PC = 1 FT.
720	2105164	NUT, NYLOC 5/16".....	4	REPLACES P/N 492582

ELECTRONIC COMPONENTS ASSY.

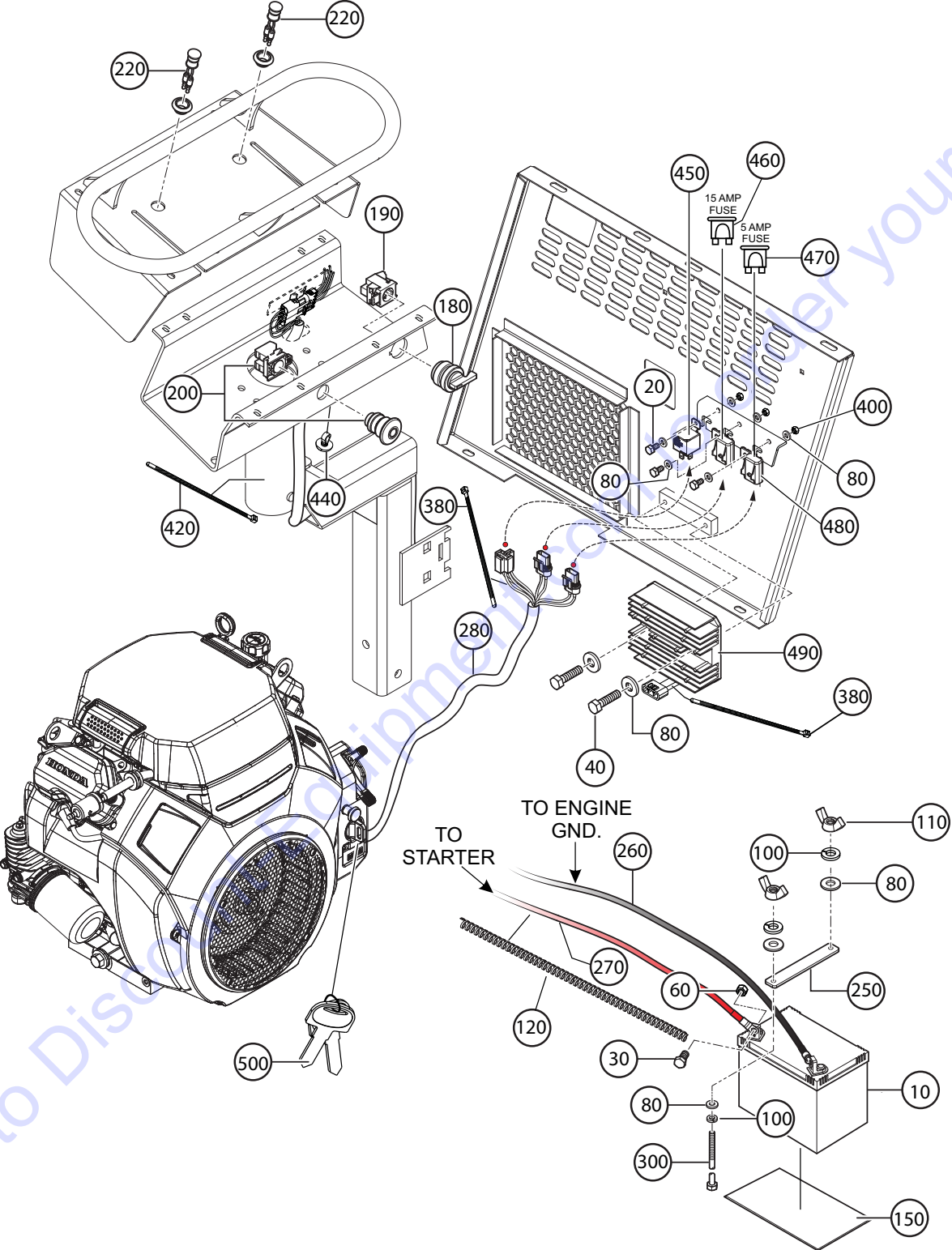

ELECTRONIC COMPONENTS ASSY.

<u>NO.</u>	<u>PART NO.</u>	<u>PART NAME</u>	<u>QTY.</u>	<u>REMARKS</u>
10	4671	BATTERY, 12V GROUP U1 WET CELL	1	
20	503115	SCREW, 3/16"X 3/4" NC GRD. 2	3	
30	492309	BOLT, 3/8" X 3/4" NC GRD. 2	2	
40	492357	BOLT, 1/4"X 1" NC GRD. 5	2	
60	492542	NUT, 3/8" NC	2	
80	492595	WASHER, FLAT 1/4"	12	
100	2101402	WASHER, LOCK 1/4" DIA.	2	REPLACES P/N 492622
110	505500	WING NUT, 1/4"	2	
120	506153	SPIRAL PLASTIC WRAP 33 IN (850 MM).....	1	1 PC. = 1 FT.
150	508480	PLATFORM, BATTERY SUPPORT	1	
180	518767	SWITCH, PARKING BRAKE, 2-POSITION	1	
190	518769	CONTACT BLOCK, PARKING BRAKE SW.	1	
200	519795	SWITCH, EMERGENCY STOP	1	
220	801708	LAMP, RED	2	
250	806526	BATTERY SUPPORT BRACKET	1	
260	806569	BATTERY CABLE (NEG.) 36 IN. (920 MM)	1	
270	806570	BATTERY CABLE (POS.) 32.5 IN. (827 MM)	1	
280	806669	WIRE HARNESS	1	
300	806921	SCREW, 1/4" X 7-1/2" NC GRD. 2	2	
380	491030	TIE-WRAP, 2.5X165 MM	14	
400	503119	NUT, NYLOC 3/16"	3	
420	517659	TIE-WRAP, 4.7X370 MM	2	
440	TK6675734	PLASTIC RETAINER, CLIP 7.7X385 MM	1	
450	802378	RELAY, 12 VDC	1	
460	23284-150	FUSE 15 AMP	1	
470	23284-050	FUSE 5 AMP	1	
480	EM98066	HOLDER, FUSE	2	
490	31750Z2E803	RECTIFIER ASSY., REGULATOR 20A	1	
500	35110ZV5V50	KEY SET, COMBINATION SWITCH	1	

ENGINE MOUNTING/MUFFLER ASSY.

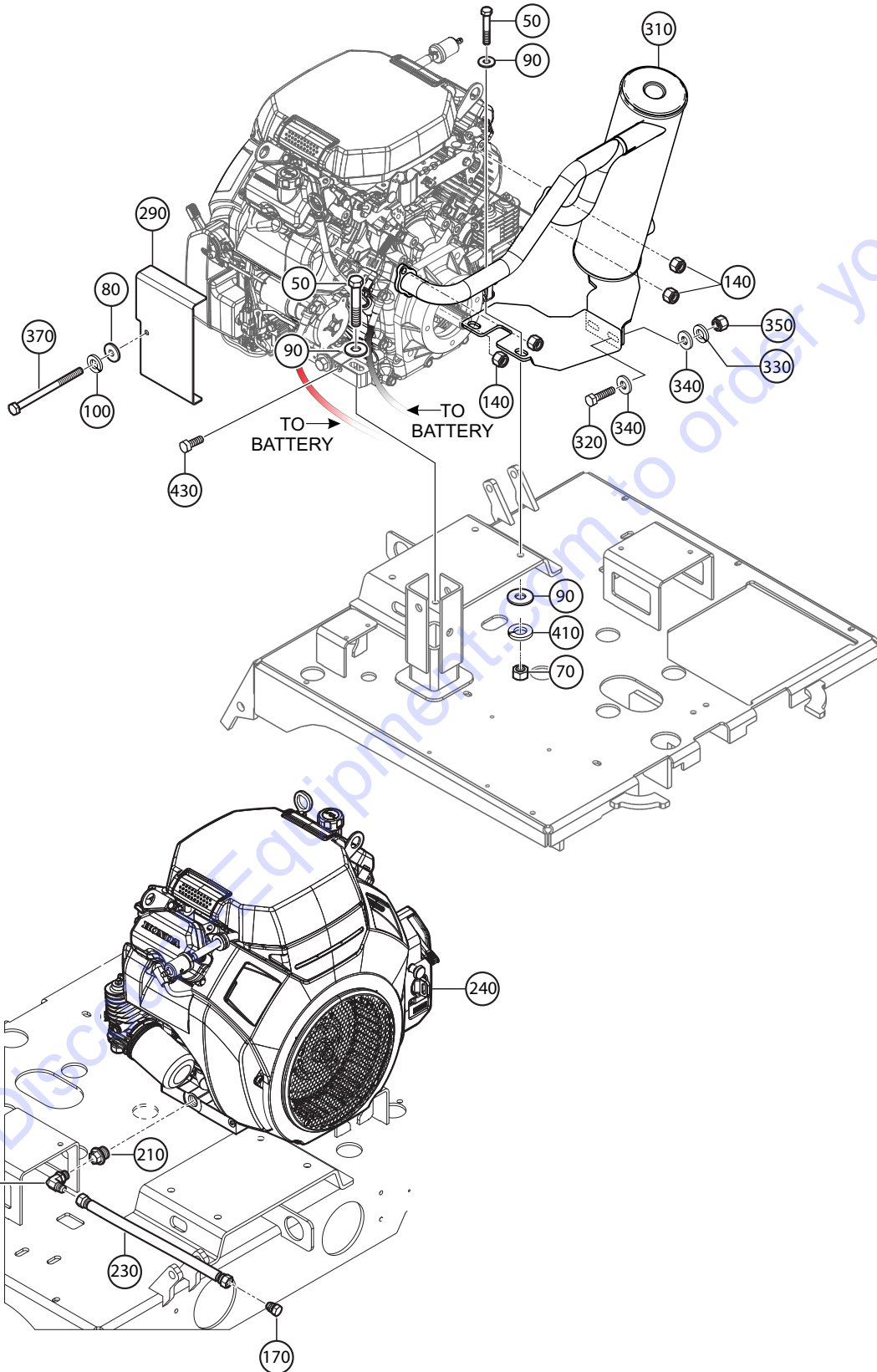

ENGINE MOUNTING/MUFFLER ASSY.

<u>NO.</u>	<u>PART NO.</u>	<u>PART NAME</u>	<u>QTY.</u>	<u>REMARKS</u>
50	492380	SCREW 3/8" X 2-1/4" NC GRD. 5	4	
70	1456	NUT, HEX 3/8"	4	REPLACES P/N 492554
80	492595	WASHER, FLAT 1/4"	1	
90	3019092	WASHER, FLAT 3/8"	8	REPLACES P/N 492598
100	2101402	WASHER, LOCK 1/4" DIA.	1	REPLACES P/N 492622
130	506196	90° ELBOW	1	
140	020108060	NUT, M8	4	REPLACES P/N 508341
170	513619	PLUG, OIL DRAIN HOSE	1	
210	807073	FITTING, ENGINE OIL DRAIN	1	
230	802922	HOSE, OIL DRAIN	1	
240	806017	ENGINE, HONDA GX690, 22HP	1	
290	806801	COVER, ENGINE WIRE HARNESS	1	
310	806993	MUFFLER, KIT	1	
320	492302	SCREW, 5/16"X 1" NC GRD.	2	
330	492623	WASHER, LOCK 5/16"	2	
340	EM923057	WASHER, FLAT 1/4"	4	REPLACES P/N 492596
350	492541	NUT, HEX 5/16" GRD. 2	2	
370	806887	SCREW, M6 X 85	1	
410	492624	WASHER, LOCK 3/8"	4	

FUEL TANK ASSY.

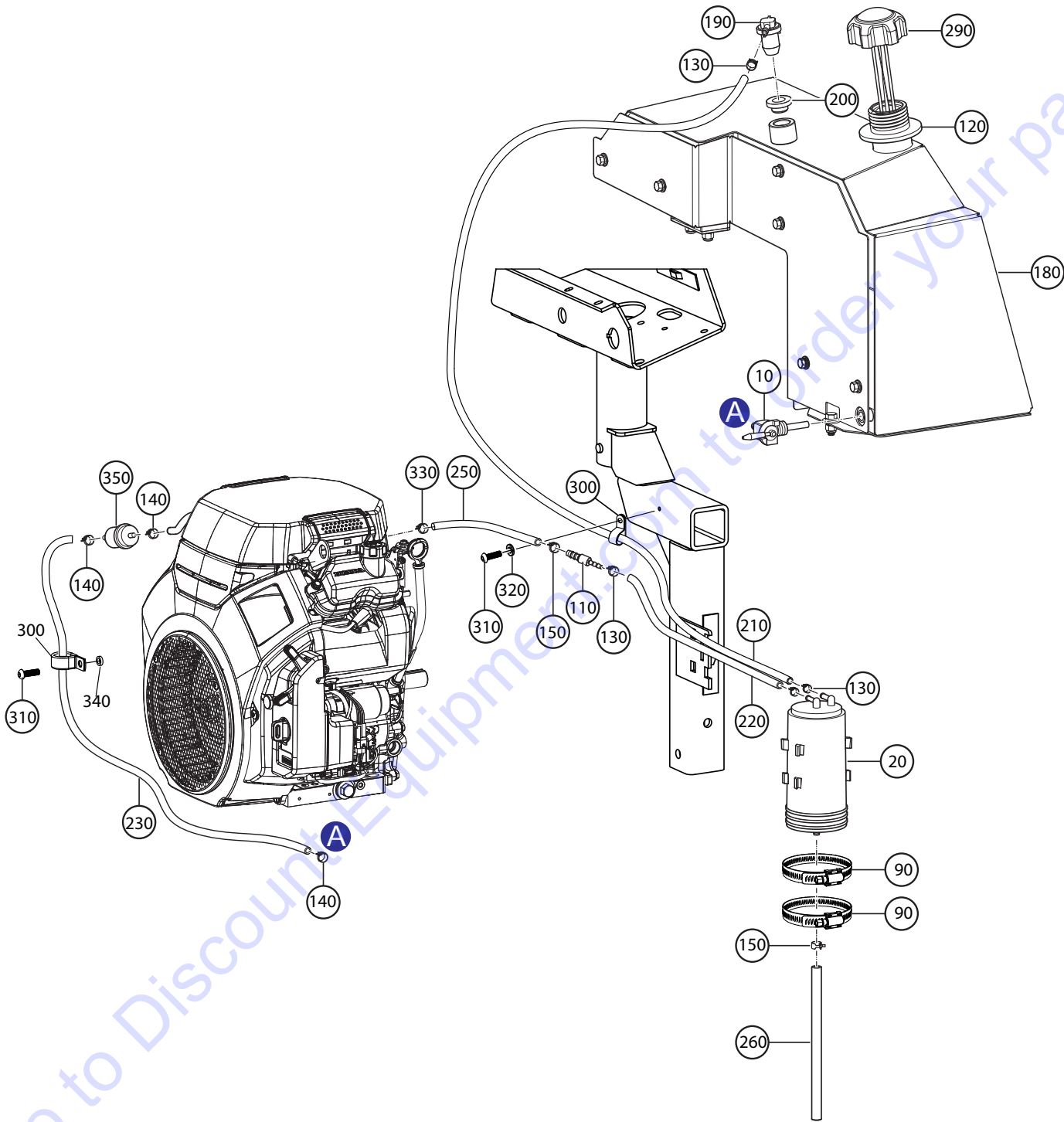

FUEL TANK ASSY.

<u>NO.</u>	<u>PART NO.</u>	<u>PART NAME</u>	<u>QTY.</u>	<u>REMARKS</u>
10	22081	VALVE, FUEL SHUTOFF 1/4NPT X 1/4" HOSE	1	
20	23506	CANISTER, CARBON 800CC	1	
90	493108	CLAMP, CHARCOAL CANISTER	2	
110	800416	HOSE, REDUCER 5/16" TO 3/16"	1	
120	802006	SEAL, FUEL TANK	1	
130	802498	CLAMP, FUEL HOSE	4	
140	802574	CLAMP, FUEL HOSE	3	
150	802575	CLAMP, FUEL HOSE	2	
180	806585	FUEL TANK	1	
190	EM202772	VENT VALVE EPA	1	
200	EM203403	GROMMET, VENT VALVE	1	
210	520833	HOSE, FUEL EPA 3/16" 1.6 FT. (.5 M)	1	
220	520833	HOSE, FUEL EPA 3/16" 9 IN. (.23 M)	1	
230	520611	HOSE, FUEL EPA 1/4" 4 FT. (1.2 M)	1	
250	520612	HOSE, FUEL EPA 5/16" 2.75 IN. (.07 M)	1	
260	520612	HOSE, FUEL EPA 5/16" 8.6 IN. (.22 M)	1	
290	806947	CAP, FUEL TANK BLK.	1	
300	801130	CLAMP	2	
310	DULT100443	BOLT, M6 X 20	2	
320	2102402	WASHER, LOCK 1/4"	1	
330	506208	CLAMP	1	
340	807340	SPACER, PLASTIC	1	
350	16910Z6L003	FUEL FILTER, IN-LINE	1	

FUEL TANK ENCLOSURE ASSY.

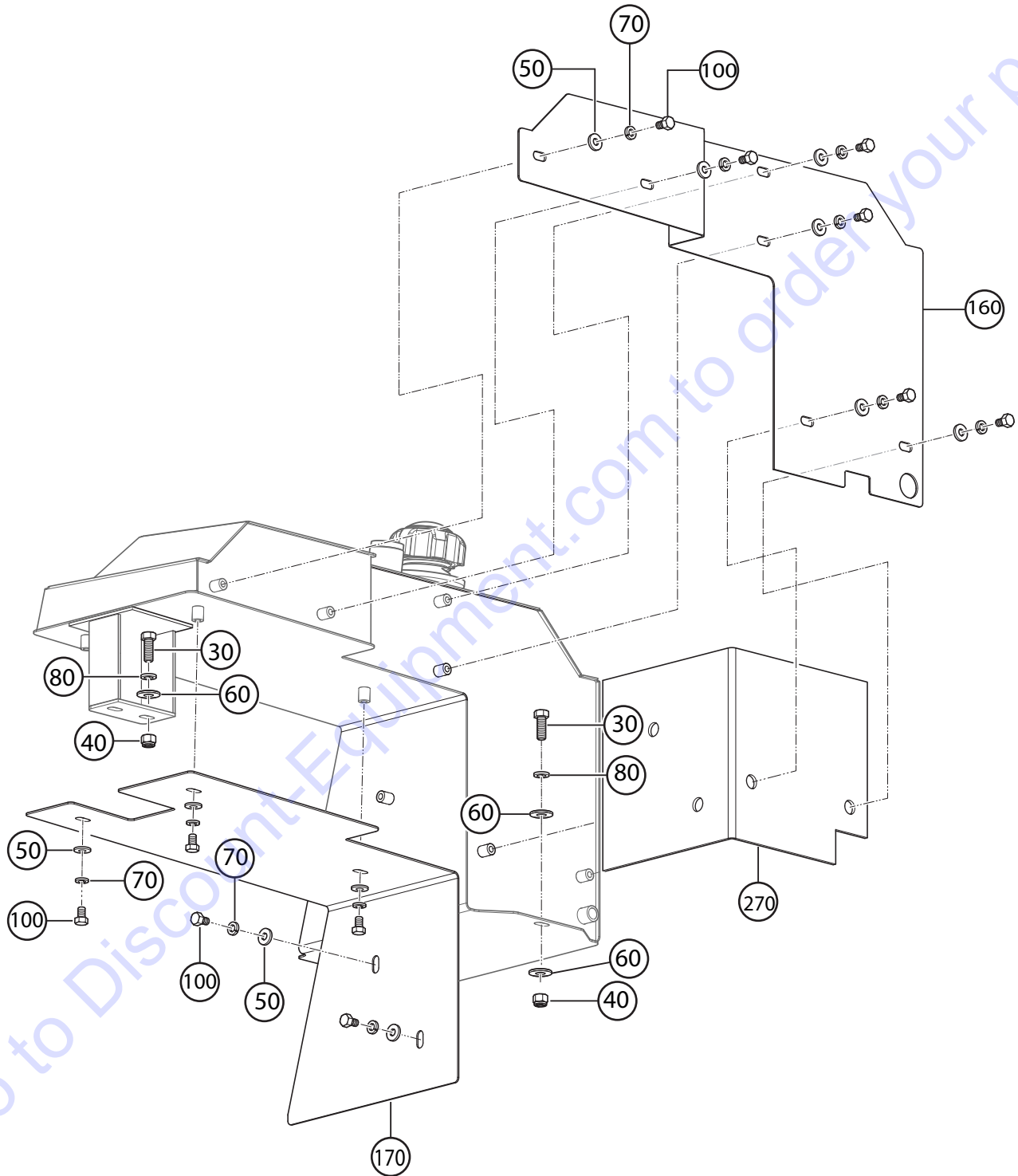

FUEL TANK ENCLOSURE ASSY.

<u>NO.</u>	<u>PART NO.</u>	<u>PART NAME</u>	<u>QTY.</u>	<u>REMARKS</u>
30	EM963610	CAP SCREW 3/8"X1-1/4" NC GRD. 8	4.....	REPLACES P/N 492375
40	EM969013	NUT, NYLOC 3/8"X 1" NC GRD. 5.....	4.....	REPLACES P/N 492583
50	EM923057	WASHER, FLAT 1/4".....	11.....	REPLACES P/N 492596
60	3019092	WASHER, FLAT 3/8".....	4.....	REPLACES P/N 492598
70	EM923343	WASHER, LOCK 5/16"	11.....	REPLACES P/N 492623
80	0166A	WASHER, LOCK 3/8"	4.....	REPLACES P/N 492624
100	492363	SCREW HHC 5/16-18 X 3/4"	11	
160	806463	HEAT SHIELD, SIDE, FUEL TANK	1	
170	806464	HEAT SHIELD, BOTTOM, FUEL TANK	1	
270	806945	HEAT SHIELD, HYDRAULIC TANK	1	

Go to Discount-Equipment.com to order your parts

PANELS ASSY.

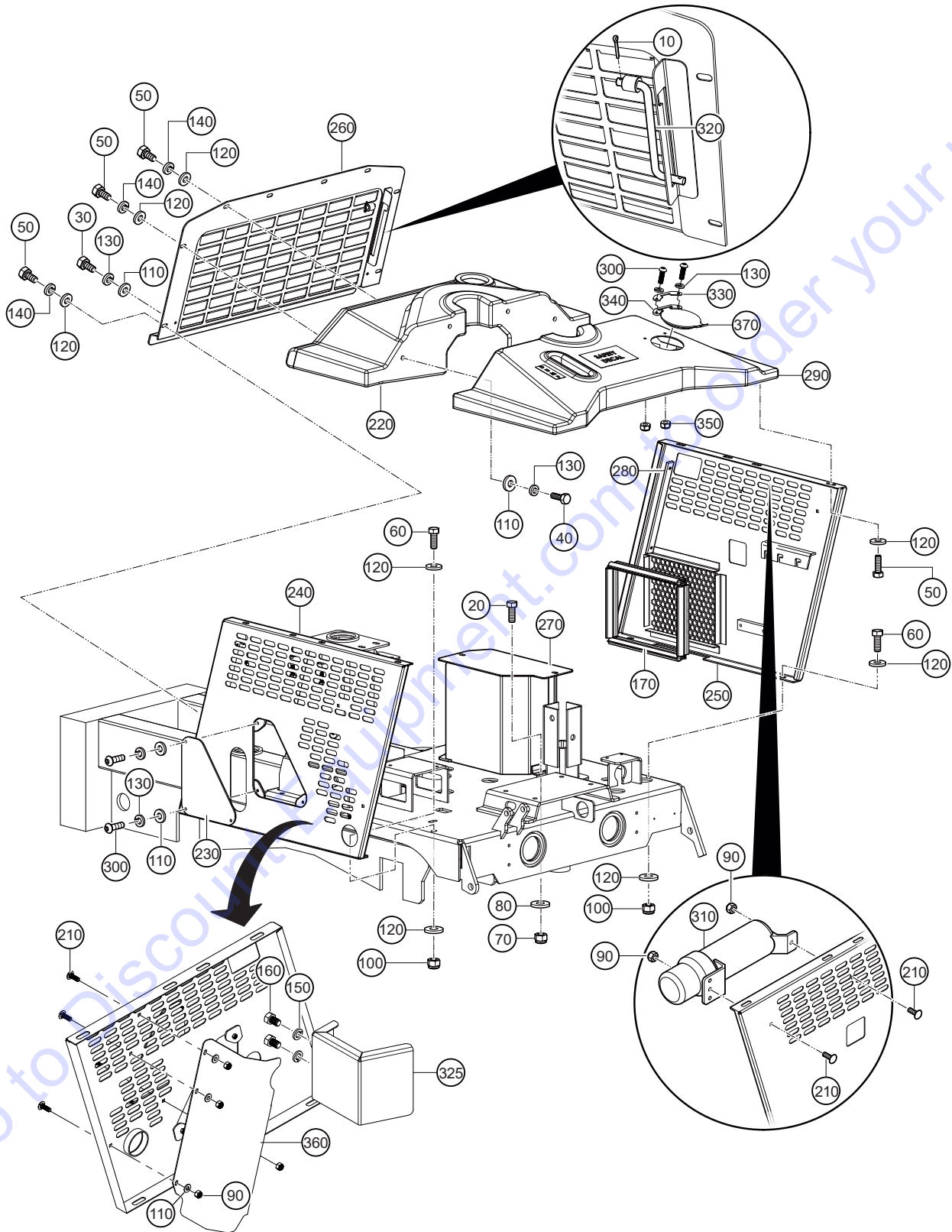

PANELS ASSY.

<u>NO.</u>	<u>PART NO.</u>	<u>PART NAME</u>	<u>QTY.</u>	<u>REMARKS</u>
10	EM491686	PIN, COTTER	2.....	REPLACES P/N 491686
20	492311	SCREW, 3/8" X 1" NC GRD. 2	2	
30	1579	SCREW, HHC 1/4-20 X 1/2"	2.....	REPLACES P/N 492355
40	492356	BOLT, 1/4" X 3/4"	4	
50	492363	BOLT, 5/16" X 3/4" NC GRD 5	16	
60	0202	SCREW, HHC 5/16" X 18" X 1"	5.....	REPLACES P/N 492364
70	1456	NUT, HEX 3/8"	2.....	REPLACES P/N 492554
80	492598	WASHER, FLAT 3/8"	2	
90	492581	NUT, NYLOC 1/4"-20	5	
100	2105164	NUT, NYLOC 5/16"-18	5.....	REPLACES P/N 492582
110	492595	WASHER, FLAT 1/4"	13	
120	492597	WASHER, FLAT 3/8"	26	
130	2101402	WASHER, LOCK 1/4" DIA.	11.....	REPLACES P/N 492622
140	EM923343	WASHER, LOCK 5/16"	8.....	REPLACES P/N 492623
150	509161	WASHER, FLAT 5/16"	8	
155	610918	WASHER, LOCK 1/2"	2	
160	504456	HEX. HEAD BOLT 1/2" NC X 3/4" G5	2	
170	520230	RUBBER SEAL, HEAT EXCH. 3.3 FT. (1 M).....	1.....	1 PC. = 1 FT.
210	800056	BOLT, 1/4" UNC X 3/4"	7	
220	800845	COVER, FUEL TANK UPPER	1	
230	806437	ACCESS PANEL, DUMP VALVE	1	
240	806451	PANEL, LEFT-SIDE	1	
250	806504	PANEL, RIGHT-SIDE	1	
260	806507	DOOR, ACCESS	1	
270	806529	COVER FAN	1	
280	806545	SUPPORT BRACKET, PANEL	2	
290	806625	COVER, FUEL TANK LOWER	1	
300	100443	BOLT, M6X 20	5	
310	23297	MANUAL HOLDER	1	
320	806511	PANEL, SUPPORT ROD	1	
325	808188	COVER, RETURN FILTER	1	
330	803301	SUPPORT BRACKET	1	
340	803300	SUPPORT HINGE	1	
350	DULT100078	NUT, NYLOC M6	2	
360	807076	COVER, MUFFLER	1	
370	807051	OIL ACCESS COVER	1	

ENGINE SERVICE PARTS

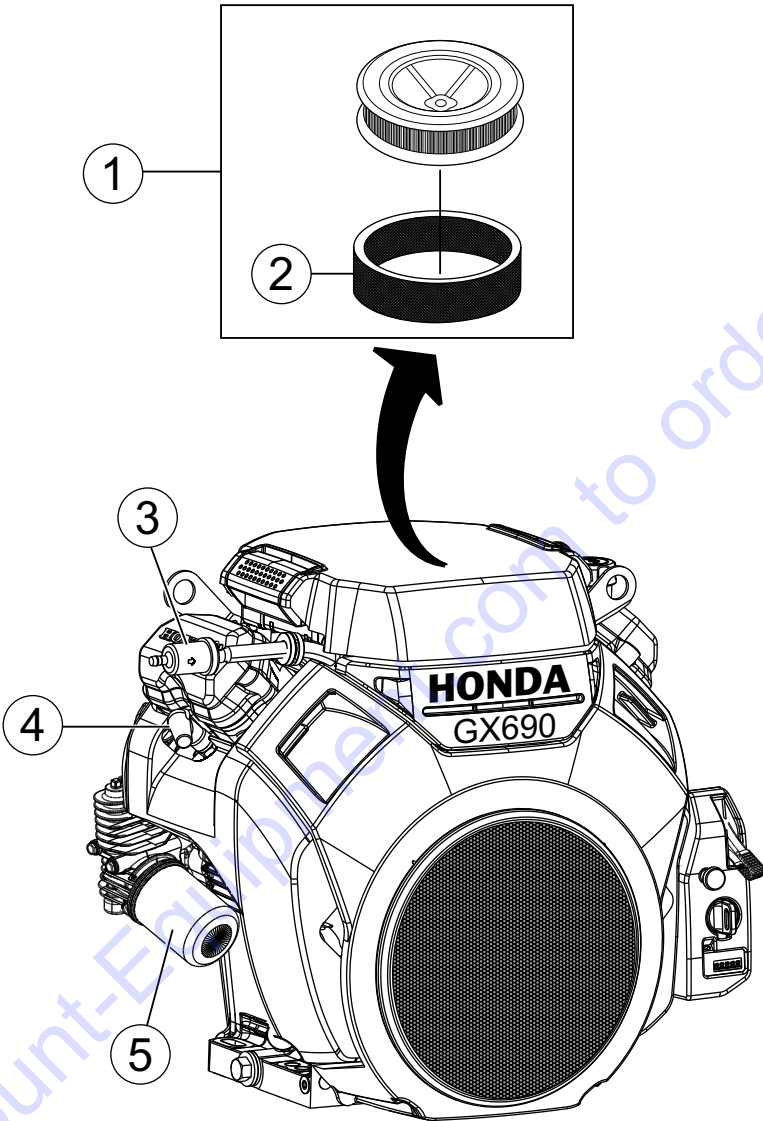

ENGINE SERVICE PARTS

<u>NO.</u>	<u>PART NO.</u>	<u>PART NAME</u>	<u>QTY.</u>	<u>REMARKS</u>
1	17210Z6L010	ELEMENT AIR CLEANER COMPLETE	1.....	INCLUDES ITEMS W/\$
2\$	17218Z6L000	FILTER, OUTER AIR	1	
3	16910Z6L003	FILTER, IN-LINE FUEL	1	
4	980795587G	SPARK PLUG (ZFR5F)	1	
5	15400RTA003	CARTRIDGE, OIL FILTER	1	

Go to Discount-Equipment.com to order your parts

PARTS FINDER

**Search Website
by Part Number**



**Search Manual
Library For Parts
Manual & Lookup Part
Numbers – Purchase
or Request Quote**

Search Manuals

Enter your information to help us find the right parts manual for your machine.

* Brand:

* Model:

* Serial:

* Part Number:

SEARCH

**Can't Find Part or
Manual? Request Help
by Manufacturer,
Model & Description**

Parts Order Form

Please fill in the following information to help us find the right part for your machine.

Manufacturer:	<input type="text"/>
Model:	<input type="text"/>
Description:	<input type="text"/>
Part Number:	<input type="text"/>
Quantity:	<input type="text"/>
Notes:	<input type="text"/>

Discount-Equipment.com is your online resource for quality parts & equipment.

Florida: **561-964-4949** Outside Florida TOLL FREE: **877-690-3101**

Need parts?

Click on this link: <http://www.discount-equipment.com/category/5443-parts/> and choose one of the options to help get the right parts and equipment you are looking for. Please have the machine model and serial number available in order to help us get you the correct parts. If you don't find the part on the website or on one of the online manuals, please fill out the request form and one of our experienced staff members will get back to you with a quote for the right part that your machine needs.

We sell worldwide for the brands: Genie, Terex, JLG, MultiQuip, Mikasa, Essick, Whiteman, Mayco, Toro Stone, Diamond Products, Generac Magnum, Airman, Haulotte, Barreto, Power Blanket, Nifty Lift, Atlas Copco, Chicago Pneumatic, Allmand, Miller Curber, Skyjack, Lull, Skytrak, Tsurumi, Husquvarna Target, Stow, Wacker, Sakai, Mi-T-M, Sullair, Basic, Dynapac, MBW, Weber, Bartell, Bennar Newman, Haulotte, Ditch Runner, Menegotti, Morrison, Contec, Buddy, Crown, Edco, Wyco, Bomag, Laymor, EZ Trench, Bil-Jax, F.S. Curtis, Gehl Pavers, Heli, Honda, ICS/PowerGrit, IHI, Partner, Imer, Clipper, MMD, Koshin, Rice, CH&E, General Equipment, Amida, Coleman, NAC, Gradall, Square Shooter, Kent, Stanley, Tamco, Toku, Hatz, Kohler, Robin, Wisconsin, Northrock, Oztec, Toker TK, Rol-Air, APT, Wylie, Ingersoll Rand / Doosan, Innovatech, Con X, Ammann, Mecalac, Makinex, Smith Surface Prep, Small Line, Wanco, Yanmar