



**YANMAR**

**WHEEL LOADER**

**V3-6**

**V4-6**



**YANMAR · YOUR BEST PARTNER FOR BUILDING THE FUTURE**

# Stable Ride, Smooth to Operate, Great Mobility on Big Jobsites, Highly Maneuverable in Tight Areas.

Flexible Absorption of  
Uneven Ground.

## Rear Axle Oscillation

The traction force of the machine is transmitted securely in uneven terrain through the use of rear axle oscillation. It reduces operator fatigue and helps keep bucket or load level.



Dual-Mode Control for Multiple Jobs.

## Fully Automatic Mode

Just press the accelerator. The machine will accelerate smoothly and change travel speed automatically.

## Fixed Speed Mode



Maximum travel speed is fixed at low speed mode irrespective of accelerator operation. Powerful, smooth job operation at a low traveling speed – a convenient mode for jobs in restricted areas.







Everyone's a Skilled Operator Now.

**Auto-Leveler**

A single lever operation places the bucket level on the ground, automatically. The bucket moves swiftly back to the scooping position after dumping. It makes everyone a skilled operator.



**Mechanical Parallel Linkage**

Equally effective with pallet forks and other non-bucket attachments.

**A Large, Sturdy Counter-weight Guards the Rear.**

Damage to the rear is common in loader work. The rear, including turn signals, is securely protected by a large cast iron counter-weight. It is safe, sturdy and strong. Good stability is, of course, maintained during loader work.



# Designed for Both Work And Comfort

## High Performance for Loading, Moving and All Other Basic Tasks

Single Lever Operation for Forward/Reverse.

### Column Shift with Safety Lock

A single lever operation for shuttle shifting between forward/reverse. A safety lock prevents mis-operation.

F-R gear change lever

F-R gear change lever lock

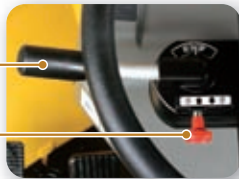

As Easy as Driving a Car.

### Parking Brake Pedal and Release Lever

Just push on the pedal to apply the parking brake. Hydraulic cut-off system prevents the machine from moving while the brake is on. The brake is released by a lever.



Release lever

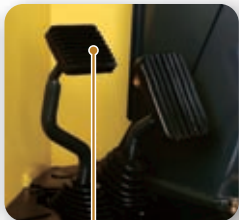

Parking brake pedal

### Inching Pedal

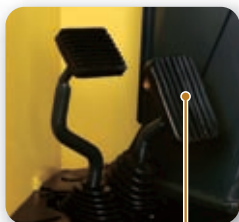

Inching Pedal

A pedal connects / disconnects engine transmission. Push down to disconnect the drive force and release to reconnect the engine.

Clear Instrument Panel

Power steering wheel

Spacious legroom







**Hazard lights flasher**

**Brake pedal**

**Accel pedal**

**Bucket operation lever**

Roomy Seat and Plenty of Space for Getting in and Out

**Suspension Seat & Walkthrough Design**

Comfortable suspension seat with retractable seatbelt and reclining back. Get in and out from either side with this walk-through design.



Smooth and Simple Bucket Work

**Loader Joystick**



Up, down, tilt, dumping and floating as well as return to dig function.

Auxiliary Hydraulics

**PTO**

For the use of additional attachments, PTO is piped to the front.



# Safe, Productive and Designed for Easy Daily Maintenance

YANMAR WHEEL LOADER

## V3-6 V4-6



Convenient grip with mirror



Two-stage step for safe mounting/dismounting



Flasher and side combination work light



Backup light and buzzer for safe reversing

### Wide Access for Easy Maintenance.

The hood opens wide. Remove the hood and floor plate to view the power line from the engine to HST transmission at a glance. It is easy to service even those usually hard to reach areas.



Easy floor plate removal





# Warm and Comfortable in the Cold

YANMAR WHEEL LOADER

V3-6 V4-6



## Deluxe ROPS cabin

A large cabin for a spacious operating environment and great visibility with wide glass window. Heater and front and rear wiper with window washer equipped as standard.



heater



rearview mirror & interior light



drink holder



defroster

※Air conditioner is available as option.

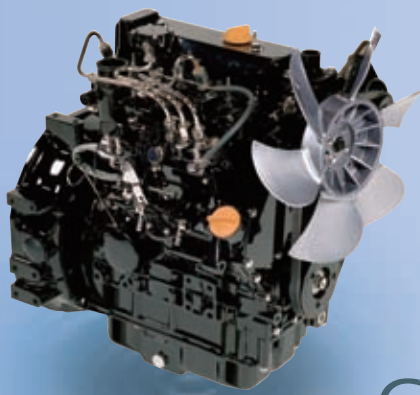

A Clean & Silent Engine that Complies with EPA Requirements.

## New C&S Engine

Equipped with Yanmar's new TNV series engines, in full compliance with EPA regulations. These are the low exhaust engines for a more ecological age.

## Ultra Quiet Loader + Low Fuel Consumption

Silent diesel engine with sophisticated measures for reducing noise. The result is an ultra quiet loader, friendly not only to the operator but to the whole community. Low fuel consumption will also slash operating costs.

# Clean & Silent

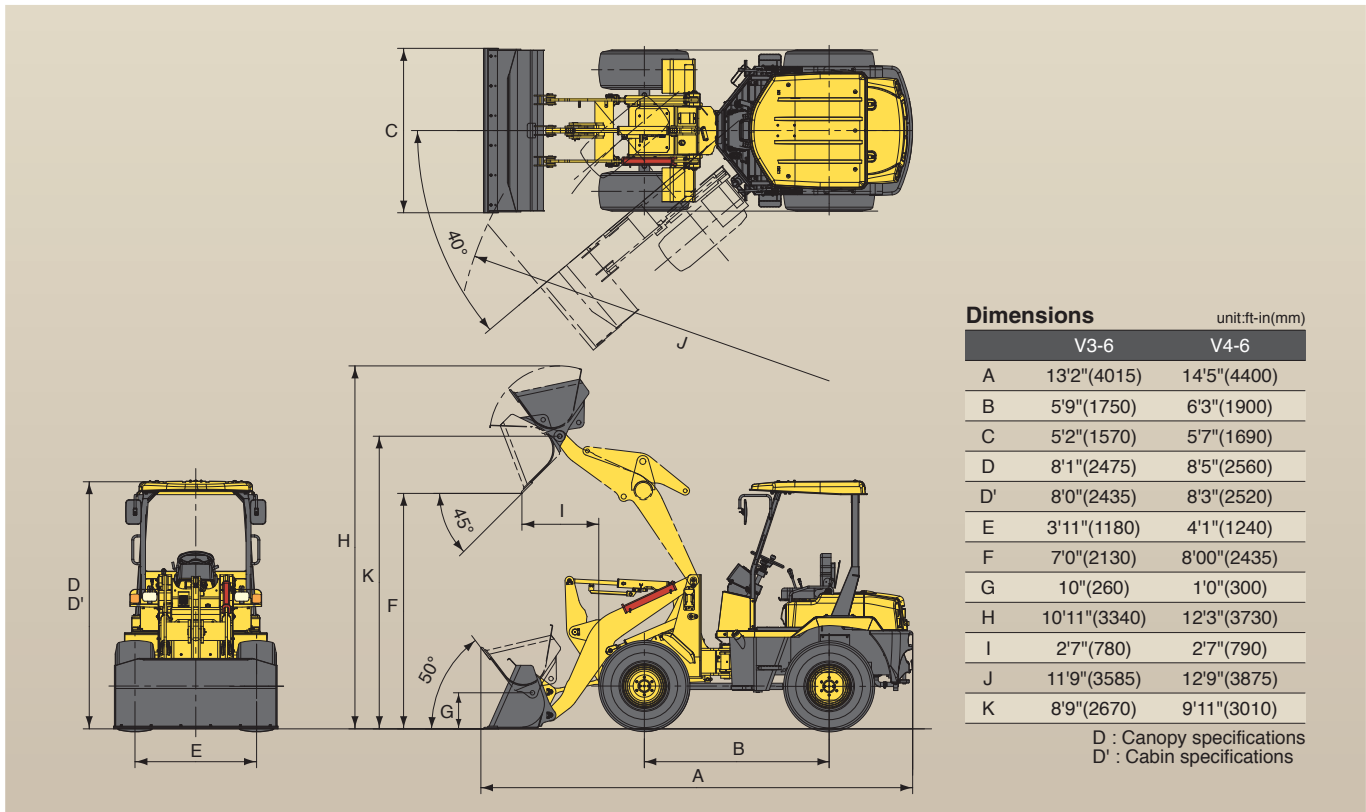

Dimensions		unit:ft-in(mm)	
	V3-6	V4-6	
A	13'2"(4015)	14'5"(4400)	
B	5'9"(1750)	6'3"(1900)	
C	5'2"(1570)	5'7"(1690)	
D	8'1"(2475)	8'5"(2560)	
D'	8'0"(2435)	8'3"(2520)	
E	3'11"(1180)	4'1"(1240)	
F	7'0"(2130)	8'00"(2435)	
G	10"(260)	1'0"(300)	
H	10'11"(3340)	12'3"(3730)	
I	2'7"(780)	2'7"(790)	
J	11'9"(3585)	12'9"(3875)	
K	8'9"(2670)	9'11"(3010)	

D : Canopy specifications  
D' : Cabin specifications

### Specifications

MODEL		V3-6	V4-6		
ENGINE	Type	water-cooled 3-cyl. diesel	water-cooled 4-cyl. diesel		
	Model	YANMAR 3TNV88-BNKAH	YANMAR 4TNV88-BNKAH		
	Output	HP(kW)/min <sup>-1</sup>	30.3(22.6) /2500	40.4(30.1) /2500	
PERFORMANCE	Displacement	cu.in(ft)	100.2 (1.642)	133.6 (2.189)	
	Std. bucket capacity	cu.yd(m <sup>3</sup> )	0.52 (0.4)	0.65 (0.5)	
	Operating load	lb(kN)	1962 (8.7)	2579 (11.5)	
	Lifting capacity at low end	lb(kN)	5760 (25.6)	7451 (33.1)	
	Tipping load	straight	lb(kN)	4785 (21.3)	5976 (26.6)
		full turn	lb(kN)	3924 (17.4)	5158 (22.9)
	Breakout force	lb(kN)	5400 (24.0)	6085 (27.1)	
	Dumping clearance	ft-in(mm)	7'0" (2130)	8'00" (2435)	
	Traveling speed	mph(km/h)	11.8 (19.0)	11.8 (19.0)	
	Oscillation angle	degree	±8		
	Min.turning radius	ft-in(mm)	11'9" (3585)	12'9" (3875)	
Min.ground clearance	ft-in(mm)	10" (260)	1'0" (300)		
PTO	Front Hyd.PTO	PSI(kPa)	3000(20590)		
		GPM(L/min)	10.7 (40.5)	14.8 (56.0)	
STEERING	Type	Center-pivot frame articulation with full hyd. power			
	Articulate angle	degree	40		
TRANSMISSION	Type	Automatic hydrostatic			
DRIVES	Type	4-wheel drive			
WHEELS	Type	12.5/70-16-6PR	15.5/60-18-8PR		
BRAKES	Type	Fully enclosed, mechanical, wet, multiple disc			
OPERATING WEIGHT	Canopy	lb(kg)	6801 (3085)	8058 (3655)	
	Cabin	lb(kg)	7264 (3295)	8521 (3865)	
TRANSPORT DIMENSIONS	LxWxH	ft-in	13'2"x5'2"x8'1"	14'5"x5'7"x8'5"	
		mm	4015x1570x2475	4400x1690x2560	

Note : All information presented in this Brochure is subject to change without notice.



PH: 877-690-3101  
Discount-Equipment.com  
West Palm, Tampa, and Orlando