



Service Bulletin No. CP20060224
Subject: Control Box Voltage Spike
Model: LS40D, LS40TD, LS50TD & LS60TD
Product Group: Concrete Pump
Date: February 24, 2006

SERVICE BULLETIN **Group: CP**

- Mandatory**

 Information

 Recommended Change

Series/Parts Affected:

LS40D, LS40TD, LS50TD and LS60TD Concrete Pumps

<u>Model</u>	<u>Serial Number Range</u>
LS40D	231001-250303
LS40TD	231103-240801
LS50TD	231201-260103
LS60TD	231001-260102

Please note that some units have already been modified.

SERVICE INFORMATION
<p>MANDATORY UPDATE: FAILURE TO FOLLOW INSTRUCTIONS MAY LEAD TO SEVERE DAMAGE OF THE POTTED CONTROL BOX!</p> <p>Problem:</p> <ul style="list-style-type: none"> It has been discovered that negative ground spikes are backfeeding through the electrical system into the potted interior control box. These spikes are harmful and destructive to the sensitive integrated circuits within the potted control box. <p>Solution:</p> <ul style="list-style-type: none"> To eliminate these harmful ground spikes, a 50 ohm resistor has been added to the control circuitry. The addition of this resistor will eliminate the ground spike condition that currently exists.

PARTS INFORMATION			
Quantity	Part #	Description	Remarks
1	EM98258	Wire Harness, 50Ω resistor	



PARTS FINDER

**Search Website
by Part Number**



**Search Manual
Library For Parts
Manual & Lookup Part
Numbers – Purchase
or Request Quote**

Search Manuals

Enter your information to help us find the right parts manual for your machine.

* Brand:

* Model:

* Serial:

* Part Number:

SEARCH

**Can't Find Part or
Manual? Request Help
by Manufacturer,
Model & Description**

Parts Order Form

Please fill in the following information to help us find the right part for your machine.

Manufacturer:	<input type="text"/>
Model:	<input type="text"/>
Description:	<input type="text"/>
Part Number:	<input type="text"/>
Quantity:	<input type="text"/>
Notes:	<input type="text"/>

Submit

Discount-Equipment.com is your online resource for quality parts & equipment.

Florida: **561-964-4949** Outside Florida TOLL FREE: **877-690-3101**

Need parts?

Click on this link: <http://www.discount-equipment.com/category/5443-parts/> and choose one of the options to help get the right parts and equipment you are looking for. Please have the machine model and serial number available in order to help us get you the correct parts. If you don't find the part on the website or on one of the online manuals, please fill out the request form and one of our experienced staff members will get back to you with a quote for the right part that your machine needs.

We sell worldwide for the brands: Genie, Terex, JLG, MultiQuip, Mikasa, Essick, Whiteman, Mayco, Toro Stone, Diamond Products, Generac Magnum, Airman, Haulotte, Barreto, Power Blanket, Nifty Lift, Atlas Copco, Chicago Pneumatic, Allmand, Miller Curber, Skyjack, Lull, Skytrak, Tsurumi, Husquvarna Target, Stow, Wacker, Sakai, Mi-T-M, Sullair, Basic, Dynapac, MBW, Weber, Bartell, Bennar Newman, Haulotte, Ditch Runner, Menegotti, Morrison, Contec, Buddy, Crown, Edco, Wyco, Bomag, Laymor, EZ Trench, Bil-Jax, F.S. Curtis, Gehl Pavers, Heli, Honda, ICS/PowerGrit, IHI, Partner, Imer, Clipper, MMD, Koshin, Rice, CH&E, General Equipment, Amida, Coleman, NAC, Gradall, Square Shooter, Kent, Stanley, Tamco, Toku, Hatz, Kohler, Robin, Wisconsin, Northrock, Oztec, Toker TK, Rol-Air, APT, Wylie, Ingersoll Rand / Doosan, Innovatech, Con X, Ammann, Mecalac, Makinex, Smith Surface Prep, Small Line, Wanco, Yanmar

INSTALLATION INSTRUCTIONS

WORK SAFELY!

This installation should be performed only by a qualified electrical technician following safe electrical wiring guidelines.

Required Tools/Materials

- Phillips Head Screwdriver
- Wire Cutters
- Butt Splice 16-14

Control Box Modification

1. Place the pump on secure level ground that is free of dirt and debris.
2. Disconnect the negative battery cable from the battery. Be very careful not to let the battery cable touch anything especially the frame or ground. It could produce a spike. For best results wrap the battery terminal in a cloth or non-conductive material to prevent it from coming in contact with any surface.
3. Using a phillips-head screwdriver remove the 2 retaining screws that secure the front cover to the control box.
4. Lay the front panel of the control box on its back on top of pump so that wire side is facing upwards.

Wiring Removal/Modification (Reference Figure 1)

1. Remove the wire connected between TB1-2 and SW1-5. Discard wire, it will not be used anymore.
2. Disconnect the wire connected to the **NEGATIVE** side of the engine hour meter from SW1-2 (Main Control Switch).
3. Using wire cutters, cut the terminal ring from the wire disconnected in step 2 and strip the insulation back 1/8-inch.
4. Using the supplied new wiring harness connect the terminal ring with the larger wire (10 AWG) to TB1-2.
5. Connect the terminal ring with the smaller wire (18 AWG) to SW1-5.
6. Splice the remaining wire (strip insulation 1/8-inch) from the new wiring harness to the wire coming from the **NEGATIVE** side of the engine hour meter.
7. Place the front cover back onto the control box and secure using 2 phillips head screws.
8. Reconnect the negative battery cable to the battery.

BEFORE CHANGE

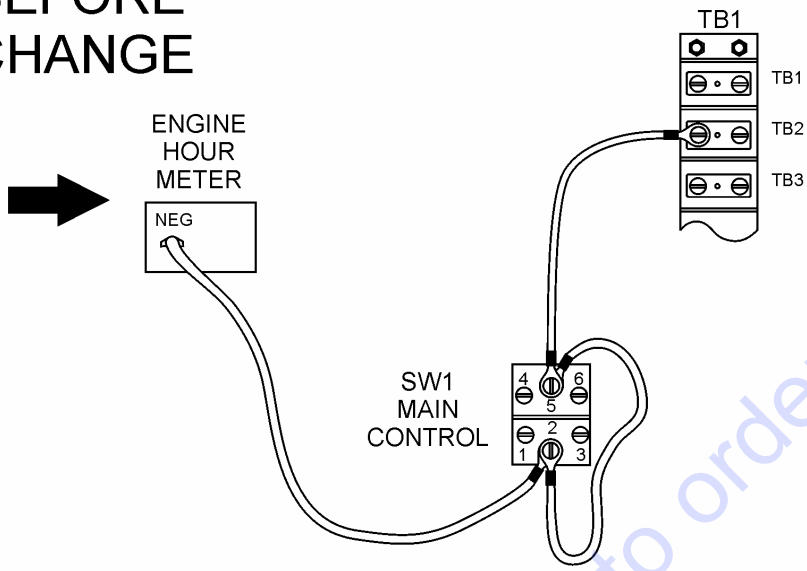

WIRE REMOVAL

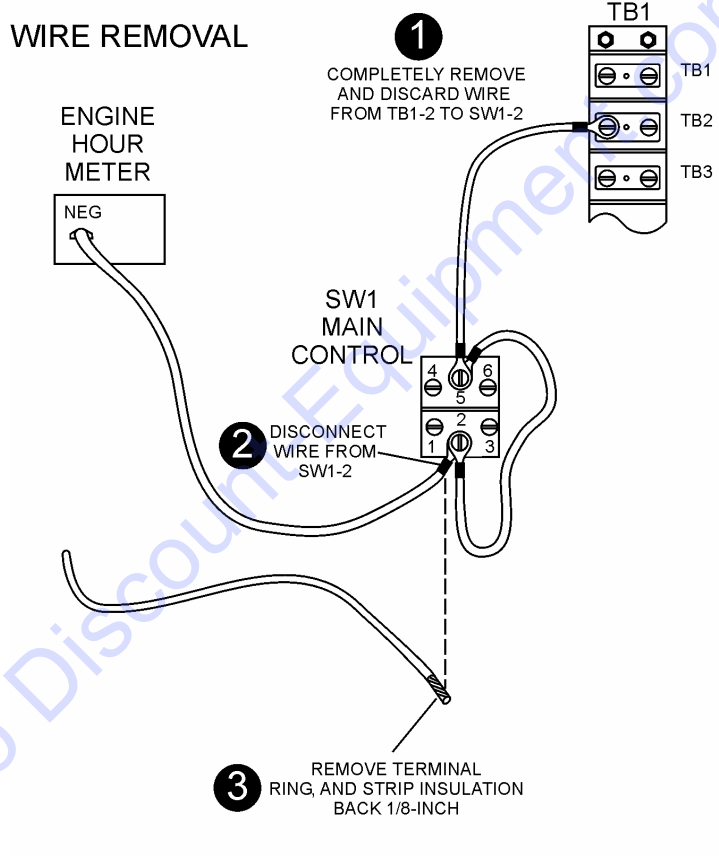

WIRE ADDITION

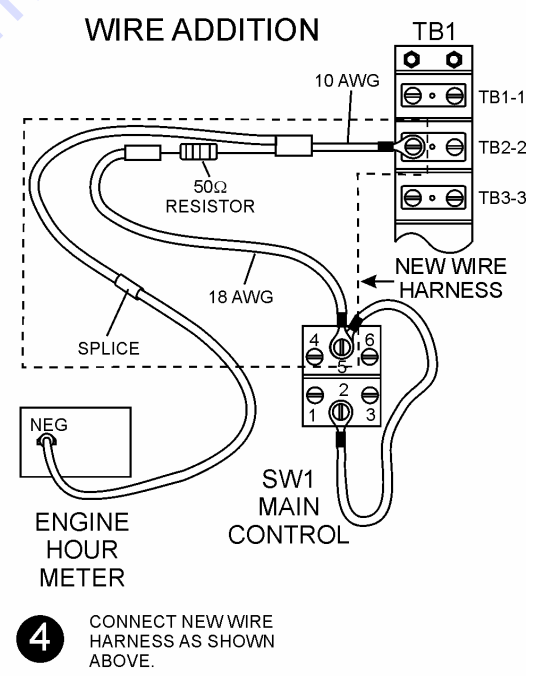

AFTER CHANGE

Figure 1 Wiring Diagram

PARTS FINDER

**Search Website
by Part Number**



**Search Manual
Library For Parts
Manual & Lookup Part
Numbers – Purchase
or Request Quote**

Search Manuals

Enter your information to search for a parts manual or lookup a part number.

* Brand:

* Model:

* Serial:

* Part Number:

SEARCH

**Can't Find Part or
Manual? Request Help
by Manufacturer,
Model & Description**

Parts Order Form

Please fill in the following information to request help finding a part or manual.

Manufacturer:

Model:

Description:

Quantity:

Part Number:

Part Name:

Part Description:

Part Category:

Part Location:

Part Status:

Part Condition:

Part Material:

Part Color:

Part Weight:

Part Dimensions:

Part Notes:

Submit

Discount-Equipment.com is your online resource for quality parts & equipment.

Florida: **561-964-4949** Outside Florida TOLL FREE: **877-690-3101**

Need parts?

Click on this link: <http://www.discount-equipment.com/category/5443-parts/> and choose one of the options to help get the right parts and equipment you are looking for. Please have the machine model and serial number available in order to help us get you the correct parts. If you don't find the part on the website or on one of the online manuals, please fill out the request form and one of our experienced staff members will get back to you with a quote for the right part that your machine needs.

We sell worldwide for the brands: Genie, Terex, JLG, MultiQuip, Mikasa, Essick, Whiteman, Mayco, Toro Stone, Diamond Products, Generac Magnum, Airman, Haulotte, Barreto, Power Blanket, Nifty Lift, Atlas Copco, Chicago Pneumatic, Allmand, Miller Curber, Skyjack, Lull, Skytrak, Tsurumi, Husquvarna Target, Stow, Wacker, Sakai, Mi-T-M, Sullair, Basic, Dynapac, MBW, Weber, Bartell, Bennar Newman, Haulotte, Ditch Runner, Menegotti, Morrison, Contec, Buddy, Crown, Edco, Wyco, Bomag, Laymor, EZ Trench, Bil-Jax, F.S. Curtis, Gehl Pavers, Heli, Honda, ICS/PowerGrit, IHI, Partner, Imer, Clipper, MMD, Koshin, Rice, CH&E, General Equipment, Amida, Coleman, NAC, Gradall, Square Shooter, Kent, Stanley, Tamco, Toku, Hatz, Kohler, Robin, Wisconsin, Northrock, Oztec, Toker TK, Rol-Air, APT, Wylie, Ingersoll Rand / Doosan, Innovatech, Con X, Ammann, Mecalac, Makinex, Smith Surface Prep, Small Line, Wanco, Yanmar