



QUICK SPECS

Weight	11,662 lbs
Horsepower	96.5 hp
Max Payload	8,380 lbs



C50R-3C

POWERFUL, EFFICIENT WATER-COOLED, 4-CYLINDER 96.5-HP INTERIM TIER 4 DIESEL ENGINE

AUTOMATIC 2-SPEED HYDROSTATIC TRANSMISSION

TOUGH UNDERCARRIAGE FOR EXTREME CONDITIONS

IDEAL FOR STEEP SLOPES, SAND, SNOW & SWAMPY CONDITIONS

CONSTANT HORSEPOWER MECHANISM MINIMIZES STALLING

OPTIONAL ENCLOSED CAB WITH HEAT & A/C

OPTIONAL BARE-TYPE BED (NO DUMP BODY OR DUMP CYLINDER)

LARGE PLATFORM AND SUFFICIENT PTO TO SERVE AS MOUNTING VEHICLE FOR MULTIPLE ATTACHMENTS

Built for the toughest jobsites on Earth.

Dump trucks are great, if they can get to the jobsite. But low ceilings, swampy or soft ground, snow and steep slopes can be obstacles to getting a job done. Not with the C50R. This durable, rubber-tracked, high-flotation, all-terrain carrier is right at home in conditions where others can't operate. Even in places where it's impossible or dangerous to turn, the seat and travel levers turn 180 degrees together so you're always moving forward. Take a seat. You'll quickly see that conditions don't decide whether a job gets done; only you do.

INNOVATIVE FEATURES



Neat, Easy Dumping For Tougher Conditions

With an ample 65-degree dumping angle and extended 2ft-2in distance from the dumping platform to the ground, you always get a sure and neat soil discharge with just a single dumping stroke. For even more versatility, add an optional 180-degree swivel dump loading platform for safe, efficient sideways dumping.



Reversible Seat and Travel Lever

The operator's seat and travel levers turn 180 degrees so the operator is always moving forward. This provides a safer work environment on mountain paths and other turn-restricted worksites. It also reduces damage to environmentally sensitive areas because there's no need to make skid turns.



Safe, Comfortable Cab

The operator's area is spacious and built for comfort. The C50 has been engineered for enhanced panoramic visibility from the operator's seat. The powerful 96.5-hp engine is also built for clean exhaust and quiet operation. Add an optional enclosed cab with heat and AC for year-round comfort.



C50R-3C

Dimensions - C50R-3B Dump Body Type

A 14 ft. 11 in. (4540 mm)	G 3 ft. 7 in (1080 mm)
B 8 ft. 8 in. (2640 mm)	H 1 ft. (300)
C 6 ft. 7 in. (2000 mm)	I 10 ft. 6 in. (3190 mm)
D 8 ft. 9 in. (2675 mm)	J 5 ft. 1 in. (1550 mm)
E 3 ft. 5 in. (1050 mm)	K 8 ft. 2 in. (2500 mm)
F 11 ft. 5 in. (3470 mm)	L 6 ft. 1 in. (1850 mm)

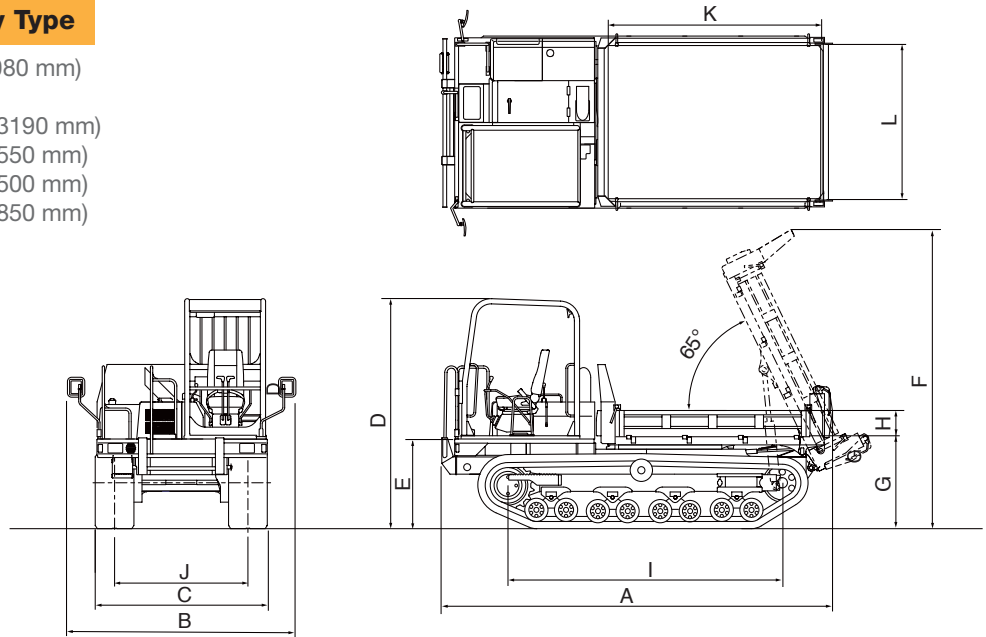

Specifications

Model		C50R-3C		
		Canopy	Cabin	
Dump Vessel Type	-	One-way dump type		
Shape of Vessel	-	Box-Shaped		
Operating Weight	With Operator's Weight	lbs (kg)	11662 (5290) 12037 (5460)	
Engine	Type	-	Water-cooled 4-cyl. diesel	
	Model	-	4JJ1X	
	Output	HP (kW)/rpm	96.5 (72) / 2200	
Transmission	-	Two-Speed Automatic Hydrostatic Transmission w/ Lockout Mechanism in Low Speed		
Undercarriage	Track Shoes	-	Steel-Reinforced Rubber Track w/ Automatic Track Tension	
	Shoe Width	ft-in (mm)	1'6" (450)	
	Min. Ground Clearance	ft-in (mm)	1'5" (435)	
	Ground Contact Pressure	w/o load	PSI (kPa)	2.43 (16.7) 2.50 (17.2)
w/ load		PSI (kPa)	4.31 (29.4) 4.33 (29.9)	
Brake	Service Brake	Type	Wet Multiple Disk Brake	
Performance	Max. Payload	lbs (kg)	8379 (3800)	
	Max. Dumping Angle	degrees	65°	
	Dump Clearance	ft-in (mm)	2'2" (670)	
	Dump Body Capacity	Struck	yd ³ (m ³)	1.8 (1.4)
		Heaped	yd ³ (m ³)	3.0 (2.3)
	Travel Speed	Forward	mph (km/h)	6.2 (10)
		Reverse	mph (km/h)	6.2 (10)
Traction Force	lbs (kg)	15655 (7100)		
Hydraulic System	Pump (for dump)	-	Gear	
	Control Valve	-	Pilot-Controlled Spool Valve	
	Pump Displacement	in ³ / rev (cm ³ / rev)	0.84 (13.7)	
	Relief Valve Pressure	PSI (MPa)	3000 (20.6)	
Fuel Tank Capacity		Gals (L)	25 (95)	