

## Easy Operation & Easy Maintenance

### Simple, Low Fatigue Hydraulic Pilot Travel Lever

The hydraulic pilot lever operation is light and easy. This means minimal fatigue for the operator even during long operation.

### Constant Horsepower Mechanism Minimizes the Risk of Engine Stalling

The power and speed are controlled automatically according to the load. Engine stalling is less likely while traveling on slopes or turning while loaded.

### Automatic 2-Speed HST Transmission for Passenger Car-like Operation

Travel is easy with automatic speed change. In addition, the operator can lock the unit in low for additional safety on inclines, etc.

### Ample Dumping Angle of 65 Degrees for Sure Discharge

In addition to the 65 degrees dumping angle, the distance from the bottom of the loading platform to the ground has been extended to 2' 2" (670 mm). This enables sure and neat soil discharge with a single dumping stroke. The swivel dump, slope end vessel is also available as an option.

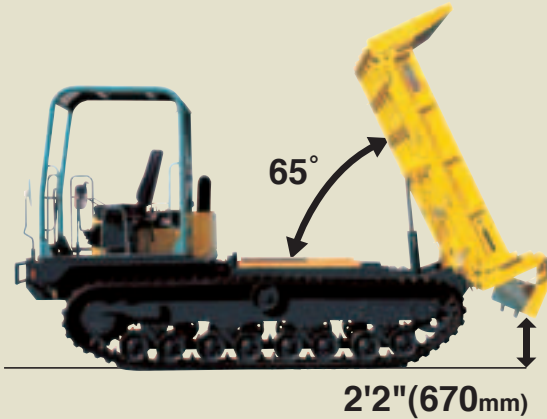

**Comfortable Operation from the Spacious Operator's Area**  
The height and width of the operator's area allows comfortable and easy operation.



### Platform for Easy Inspection and Servicing

The platform in front of the engine hood permits easy inspection and servicing access to the engine.

### Tilting Rear Mirror

The rear view mirror is on a flexible frame so it bends rather than breaks even in collisions with objects.

### Adjustment-free Travel Lever

The travel lever is hydraulic pilot type. There is no need to adjust the stroke or play as you would do with a mechanical lever.

## Clean & Silent

### An Environmental Engine Inside

Clean exhaust and powerful output. The people-friendly Clean and Silent engines are approved under the emissions and the noise regulations of the EU (Europe) and the EPA (United States).

### One-way dump type with box-shape body

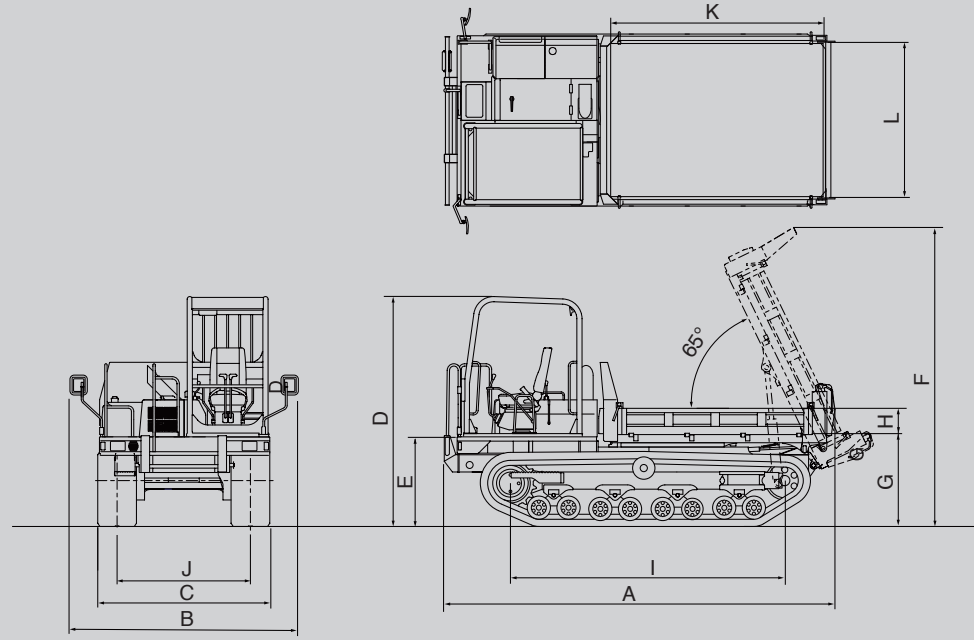

### Dimensions

		unit:ft-in(mm)											
		A	B	C	D	E	F	G	H	I	J	K	L
Dump body type	One-Way Box type	14'11" (4540)	8'8" (2640)	6'7" (2000)	8'9" (2675)	3'5" (1050)	11'5" (3470)	3'7" (1080)	1' (300)	10'6" (3190)	5'1" (1550)	8'2" (2500)	6'1" (1850)

### Specifications

Model		C50R-3C		
		Canopy	Cabin	
Dump body	Type	One-way dump type		
	Shape	Box-shaped		
Operating Mass	With operator's weight	11,660 (5,290)	12,040 (5,460)	
Engine	Type	Water-cooled 4 cyl. Diesel engine		
	Model	4JJ1X		
	Output	103.3 (77)/2,200		
Transmission		Two-speed automatic hydrostatic transmission with lockout mechanism in low speed		
Under Carriage	Track shoes	Steel reinforced rubber track with automatic track tension		
	Shoe width	1'6" (450)		
	Min. ground clearance	1'5" (435)		
	Ground contact pressure	Unloaded	2.62 (18.1)	
		Loaded	4.50 (31.0)	
Brake	Parking brake	Wet multiple disk brake		
Performance	Max. payload	8,380 (3,800)		
	Max. dumping angle	65		
	Dump clearance	2'2" (670)		
	Dump body capacity	Struck	1.8 (1.4)	
		Heaped	3.0 (2.3)	
Travel speed	Forward	5.7 (9.2)		
	Reverse	5.7 (9.2)		
Hydraulic System	Traction Force	16,300 (7,400)		
	Pump (for dump)	Gear		
	Control valve	Pilot controlled spool valve		
Fuel tank capacity	Pump displacement	0.84 (13.7)		
	Relief set pressure	3,000 (20.6)		
		22 (82)		

Note : All information presented in this Brochure is subject to change without notice.

# Discount Equipment

PH: 877-690-3101  
Discount-Equipment.com  
West Palm, Tampa, and Orlando

YANMAR

ALL TERRAIN CARRIER  
**C50R-3C**

Engine Output : 103.3hp (77kW)  
Max. travelling speed : 5.7mph (9.2km/h)  
Max. payload : 8,380lbs (3800kg)  
(\*Canopy, Box-shaped dump body)



YANMAR · YOUR BEST PARTNER FOR BUILDING THE FUTURE



**C50R-3C**  
Canopy Box-type dump bed

## Tough Undercarriage for Extreme Conditions

The Yanmar C50R-3C All-Terrain Carrier is a workhorse, especially under extreme conditions where ordinary trucks can not operate. For example, when tunneling, the slim-bodied C50R-3C with its unique revolving operator's seat offers versatility no ordinary truck can match.

The C50R-3C's high floatation capability associated with low ground pressure allows productive operation in wet muddy conditions and minimizes disturbance to environmentally sensitive areas.

The C50R-3C is ideal for use on:

- \* Steep slopes
- \* Sand
- \* Snow
- \* Soft and swampy areas

## Full Operational Comfort for Ease of Operation and Work Efficiency

### Safety operation

ROPS / FOPS cabin or canopy with seat belt protects against operator injury.



Canopy

Cabin

### Excellent Right Forward View

The right corner of the machine has been lowered to improve visibility and safety.

The normal blind spot on the front right of large machines is minimized to ensure a broad view from the operator station.



### Reversing Warning Buzzer

When reversing, the warning buzzer sounds automatically.

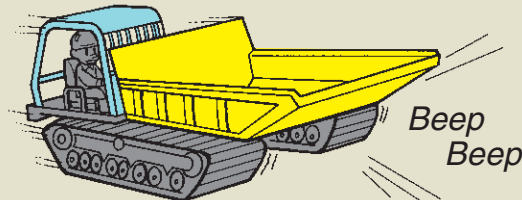

### The Reversible Travel Lever and Seat Combination Raises Work Efficiency on Narrow Jobsites.

The operator's seat and the travel levers turn 180 degrees together. The result is that the machine is always moving forward for the operator, achieving a safer work environment even on mountain paths or other restricted worksites where it is hard to turn the machine. This also reduces damage to environmentally sensitive areas because the operator does not need to make skid turns to exit a jobsite. The spacious leg room ensures easy operation and comfort.



### Safety Lever for Travel Lock

Travel is locked by raising the safety lever. The machine will not move even if the travel lever is touched by mistake.



### Automatic Parking Brake is Incorporated in the Travel Lever

When the travel lever is shifted to neutral, the parking brake functions automatically. This prevents damage due to mis-operation and brake dragging, and takes the anxiety out of parking on slopes.



## Versatile Platform Vehicle for Various Attachments

The Yanmar C50R-3C All-Terrain Carrier has a large platform and sufficient PTO capacity to serve as a mounting vehicle for many types of attachment. The C50R-3C with select mounted attachments can be used for:

- \* Boring
- \* Craning
- \* Winching
- \* Snow-making
- \* Beach cleaner
- \* Hauling pipe or tools to remote area, Fire fighting and rescue

### Bare Type

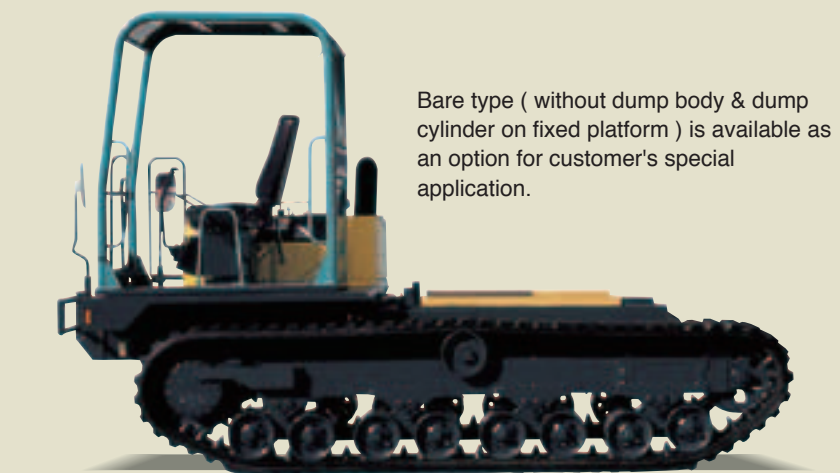

Bare type ( without dump body & dump cylinder on fixed platform ) is available as an option for customer's special application.

### Swivel Type

#### Loading Platform Swivels through 180 Degrees for Sideways Dumping

You can swivel the loading platform through 180 degrees and fix it where you like by lever operation. Sideways dumping is available as a convenient, efficient and safe feature to suit the worksite.

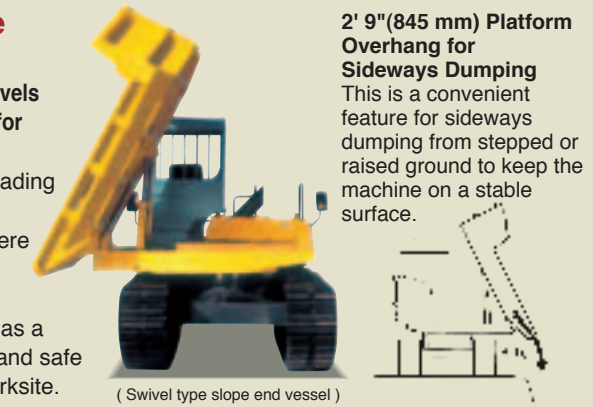

2' 9"(845 mm) Platform Overhang for Sideways Dumping  
This is a convenient feature for sideways dumping from stepped or raised ground to keep the machine on a stable surface.

( Swivel type slope end vessel )

### Main Specifications

			Bare type		Swivel dump type		
			Canopy	Cabin	Canopy	Cabin	
Operating Mass	With operator's weight	lbs (kg)	10,160(4,610)	10,530(4,780)	12,650(5,740)	13,030(5,910)	
Engine	Output	hp(kW)/RPM	103.3(77) / 2,200				
Under carriage	Shoe width	ft-in (mm)	1'6" (450)				
	Min. ground clearance	ft-in (mm)	1'5" (435)				
	Ground contact pressure	Unloaded psi (kPa)	2.27 (15.7)	2.36 (16.2)	2.84 (19.6)	2.93 (20.2)	
	Loaded	psi (kPa)	—	—	4.58 (31.5)	4.66 (32.1)	
Performance	Max. loading capacity	lbs (kg)	9,870(4,480)				
	Max. payload (payload)	lbs (kg)	7,720 (3,500)				
	Max. dumping angle	degrees	65				
	Dump clearance	ft-in (mm)	2'11" (890)				
	Dump body capacity	Struck	yd <sup>3</sup> (m <sup>3</sup> )	—			
		Heaped	yd <sup>3</sup> (m <sup>3</sup> )	—			
	Travel speed	Forward	mph (km/h)	5.7(9.2)			
Reverse		mph (km/h)	5.7 (9.2)				
Traction Force		lbs (kg)	16,300 (7,400)				
Hydraulic system	Pump displacement	in <sup>3</sup> /rev(cm <sup>3</sup> /rev)	0.84 (13.7)				
	Relief set pressure	psi (MPa)	3,000 (20.6)				