

OPERATION AND PARTS MANUAL



J-SERIES (CHINA) WALK-BEHIND TROWEL

Revision #3 (07/07/10)



THIS MANUAL MUST ACCOMPANY THE EQUIPMENT AT ALL TIMES.

P/N 20840

PARTS FINDER

**Search Website
by Part Number**



**Search Manual
Library For Parts
Manual & Lookup Part
Numbers – Purchase
or Request Quote**

Search Manuals

Enter your information to help us find the right parts manual for your machine.

* Brand:

* Model:

* Serial:

* Part Number:

SEARCH

**Can't Find Part or
Manual? Request Help
by Manufacturer,
Model & Description**

Parts Order Form

Please fill in the following information to help us find the right part for your machine.

Manufacturer:	<input type="text"/>
Model:	<input type="text"/>
Description:	<input type="text"/>
Part Number:	<input type="text"/>
Quantity:	<input type="text"/>
Notes:	<input type="text"/>

Discount-Equipment.com is your online resource for quality parts & equipment.

Florida: **561-964-4949** Outside Florida TOLL FREE: **877-690-3101**

Need parts?

Click on this link: <http://www.discount-equipment.com/category/5443-parts/> and choose one of the options to help get the right parts and equipment you are looking for. Please have the machine model and serial number available in order to help us get you the correct parts. If you don't find the part on the website or on one of the online manuals, please fill out the request form and one of our experienced staff members will get back to you with a quote for the right part that your machine needs.

We sell worldwide for the brands: Genie, Terex, JLG, MultiQuip, Mikasa, Essick, Whiteman, Mayco, Toro Stone, Diamond Products, Generac Magnum, Airman, Haulotte, Barreto, Power Blanket, Nifty Lift, Atlas Copco, Chicago Pneumatic, Allmand, Miller Curber, Skyjack, Lull, Skytrak, Tsurumi, Husquvarna Target, Stow, Wacker, Sakai, Mi-T-M, Sullair, Basic, Dynapac, MBW, Weber, Bartell, Bennar Newman, Haulotte, Ditch Runner, Menegotti, Morrison, Contec, Buddy, Crown, Edco, Wyco, Bomag, Laymor, EZ Trench, Bil-Jax, F.S. Curtis, Gehl Pavers, Heli, Honda, ICS/PowerGrit, IHI, Partner, Imer, Clipper, MMD, Koshin, Rice, CH&E, General Equipment, Amida, Coleman, NAC, Gradall, Square Shooter, Kent, Stanley, Tamco, Toku, Hatz, Kohler, Robin, Wisconsin, Northrock, Oztec, Toker TK, Rol-Air, APT, Wylie, Ingersoll Rand / Doosan, Innovatech, Con X, Ammann, Mecalac, Makinex, Smith Surface Prep, Small Line, Wanco, Yanmar

CONGRATULATIONS ON YOUR PURCHASE OF YOUR POWER TROWEL!

Since inventing the power trowel over 50 years ago, Multiquip has pioneered almost every innovation in trowel technology. Each and every walk-behind trowel is designed-without compromise-to produce the finest possible finishes.

J-Series Trowel

Here's How To Get Help 2
 Table Of Contents 3
 General Safety Guidelines 4
 Explanation Of Codes In Remarks Column 5
 Safety Information 6

INSTRUCTIONS

Fuel 7
 Instructions 8-14
 Troubleshooting 15
 Operator Training 16
 Optional Equipment 17
 Technical Specifications 18
 Handle 20-21
 Quick Pitch Handle 22-23
 Spider and Blades 24-25
 Gear Box and Engine Mounts 26-27
 Engine 28-29

NOTE: Specification and part number are subject to change without notice.

GENERAL SAFETY GUIDELINES

Failure to follow instructions in this manual may lead to serious injury or even death! This equipment is to be used by qualified and trained personnel only. This equipment should not be operated by persons under 18 years of age.

Always use proper heavy lifting techniques when moving equipment.

Always make sure that machine is kept in proper operating condition.

Always have throttle position at idle while starting engine.

Always check to make sure that operating area is clear before starting engine.

Always test safety equipment including the safety engine kill mechanisms before operating equipment.

Never place feet on or inside the guard ring while starting the engine.

Never operate this equipment without proper protective clothing including footwear.

Always keep clear of rotating parts when operating.

Never operate with belt guard or any other guards removed.

Never leave machine unattended while running.

Never refuel while engine is running or while engine is hot.

Always refuel in a well ventilated area, away from sparks and open flames.

Never smoke while refueling.

Exhaust fumes are lethal! Operate machine in a well ventilated area, away from places where fumes can accumulate.

EXPLANATION OF CODE IN REMARK COLUMN

The following section explains the different symbols and remarks used in the Parts section of this manual. Use the help numbers found on the back page of the manual if there are any questions.

NOTICE

The contents and part numbers listed in the parts section are subject to change **without notice**. Multiquip does not guarantee the availability of the parts listed.

SAMPLE PARTS LIST

NO.	PART NO.	PART NAME	QTY.	REMARKS
1	12345	BOLT.....	1	INCLUDES ITEMS W/%
2%		WASHER, 1/4 IN.....		NOT SOLD SEPARATELY
2%	12347	WASHER, 3/8 IN....	1	MQ-45T ONLY
3	12348	HOSE		A/R ...MAKE LOCALLY
4	12349	BEARING	1	S/N 2345B AND ABOVE

NO. Column

Unique Symbols — All items with same unique symbol

(@, #, +, %, or >) in the number column belong to the same assembly or kit, which is indicated by a note in the “Remarks” column.

Duplicate Item Numbers — Duplicate numbers indicate multiple part numbers, which are in effect for the same general item, such as different size saw blade guards in use or a part that has been updated on newer versions of the same machine.

NOTICE

When ordering a part that has more than one item number listed, check the remarks column for help in determining the proper part to order.

PART NO. Column

Numbers Used — Part numbers can be indicated by a number, a blank entry, or TBD.

TBD (To Be Determined) is generally used to show a part that has not been assigned a formal part number at the time of publication.

A blank entry generally indicates that the item is not sold separately or is not sold by Multiquip. Other entries will be clarified in the “Remarks” Column.

QTY. Column

Numbers Used — Item quantity can be indicated by a number, a blank entry, or A/R.

A/R (As Required) is generally used for hoses or other parts that are sold in bulk and cut to length.

A blank entry generally indicates that the item is not sold separately. Other entries will be clarified in the “Remarks” Column.

REMARKS Column

Some of the most common notes found in the “Remarks” Column are listed below. Other additional notes needed to describe the item can also be shown.

Assembly/Kit — All items on the parts list with the same unique symbol will be included when this item is purchased.

Indicated by:

“INCLUDES ITEMS W/(unique symbol)”

Serial Number Break — Used to list an effective serial number range where a particular part is used.

Indicated by:

“S/N XXXXX AND BELOW”

“S/N XXXX AND ABOVE”

“S/N XXXX TO S/N XXX”

Specific Model Number Use — Indicates that the part is used only with the specific model number or model number variant listed. It can also be used to show a part is NOT used on a specific model or model number variant.

Indicated by:

“XXXXX ONLY”

“NOT USED ON XXXX”

“Make/Obtain Locally” — Indicates that the part can be purchased at any hardware shop or made out of available items. Examples include battery cables, shims, and certain washers and nuts.

“Not Sold Separately” — Indicates that an item cannot be purchased as a separate item and is either part of an assembly/kit that can be purchased, or is not available for sale through Multiquip.

RECOGNIZE SAFETY INFORMATION, SYMBOLS AND TERMINOLOGY

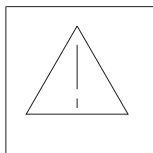

This is the **caution** symbol. Wherever you see this symbol in this manual or on the machine be aware that there is potential for personal injury or damage to equipment. Always follow instructions for safe operation and use.

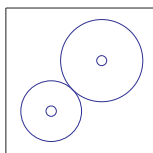

This is the symbol for **gear drive**.

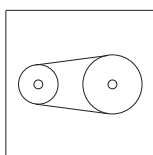

This is the symbol for **belt drive**.

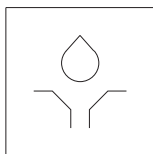

This is the symbol for **lubrication**.

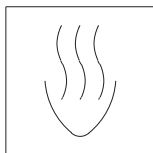

This is the symbol for **radiating heat**. Know that where you see this symbol on the machine parts may be hot.

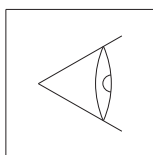

This is the symbol for **examine or check**. Know that where you see this symbol on the machine there will be something that may need to be checked for maintenance.

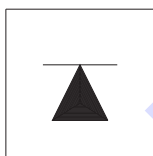

This is the symbol for **lift point**. Know that this symbol on the machine will point out possible lifting points.

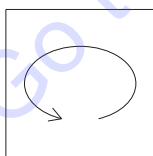

This is the symbol for **continuous rotation**. The direction, clockwise or counter clockwise will be indicated by this symbol.

FOLLOW ALL SAFETY INSTRUCTIONS

Note: If there are ANY questions regarding this manual (i.e. something is unclear) please contact Discount-equipment for clarifications.

Read ALL safety instructions carefully. Safety instructions will be found throughout this manual and on the machine. Keep all safety information in good, readable condition. If needed, replacement safety information is available. Contact Discount-equipment for replacement items and parts.

Proper machine operation includes training for operators. Operators should be versed on machine safety and operation. Never allow a person who is not properly trained to operate this equipment.

Keep this machine in proper working condition. This includes keeping all safety decals on the machine clean and visible. If decals become unreadable, please call Discount-equipment for replacements.

Do not modify this machine. Doing so may cause improper operation and may not be safe. This may also reduce machine life. Modifying this machine in any way will void the warranty.

OPERATE MACHINE SAFELY

Always be aware of the operational area of your machine. Operators need to be careful to keep bystanders and nearby objects at a safe distance from the machine. Never let someone who is untrained operate this machine.

Study the operational area carefully. Remove all dangerous objects from the finishing area. (i.e. protruding rebar or wood). Do not attempt to use the machine where operation appears to be dangerous.

Keep the machine properly maintained and in good working order. This mainly entails keeping the machine clean and serviced. This will allow the finisher to perform to it's fullest potential and provide the longest operational lifetime. Check the safety kill switch before and after every operation. It is good practice to stop the machine with the safety kill switch, to ensure it is operating properly.

Always try to do most work during daylight hours or with sufficient artificial lighting. Visibility must be good for this machine to be used effectively.

Never operate machinery when tired or ill. Operators must be alert and always looking for possible signs of danger or misuse of machinery. Do not operate the machine in dangerous surroundings.

FUEL

Handle fuel safely. Motor fuels are highly flammable and can be dangerous if mishandled. Do not smoke while refueling. Do not refuel if the engine is hot or running.

Always shut off fuel flow with the fuel line valve after every machine use. Never store the machine with fuel in the tank for any extended period of time.

Clean up spilled fuel immediately!

PERSONAL PROTECTIVE EQUIPMENT

Always wear proper clothing while operating this equipment. Protective clothing includes (but is not limited to): boots, long sleeve shirt, long pants, gloves, hearing protection and safety eyeglasses. Consult with the construction site foreman to determine what protective clothing is required on the construction site.

HAZARDOUS MATERIALS

Exposure and mishandling of hazardous material can cause personal injury or damage the environment. Potentially hazardous material used on this machine may include the following: lubricants, fuel, paints and adhesives.

Take care to handle hazardous materials properly. MSDS information sheets are available upon request.

BE PREPARED FOR EMERGENCIES

Always know the location of the nearest fire extinguisher and first aid kit. Know the location of the nearest telephone. Also know the phone numbers of the nearest ambulance, doctor and fire department. This information will be invaluable in an emergency.

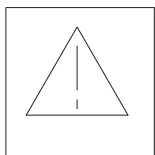

MAINTENANCE SAFETY

Caution! Disconnect spark plug wires before attempting service.

Before attempting maintenance on this machinery, know the procedure and have the correct tools. Always make sure that the machine is stopped and the spark plug wires are disconnected before attempting service.

Securely support any machine components that must be raised for service (i.e. trowel arms). Never lubricate the machine or attempt service on a running machine. Always allow the machine proper time to cool before servicing.

Keep machinery in proper running condition. Make sure that there is no buildup of concrete, grease, oil or debris. Keep all parts properly installed. Fix damage immediately and always replace worn or broken parts.

Dispose of potentially hazardous waste properly. Examples of potentially hazardous waste are: motor oil, fuel and filters. Use rigid containers for trapping these items. Do not use old food or beverage containers, someone may be misled. Do not pour waste oil or fuel directly onto the ground, down a drain or into any water source.

Inquire what the proper disposal procedures are for waste fuel and oil in your local area.

MACHINE SAFETY DECALS

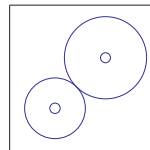

Gear Drive — Located on the gearbox.

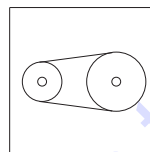

Belt Drive — Located on the belt guard.

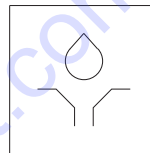

Lubrication — Located near the fill hole for gearbox lubricant.

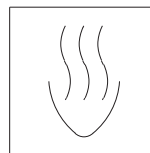

Hot! — Located on the muffler shield.

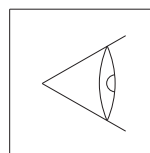

Check — Located near the oil level check for the gearbox.

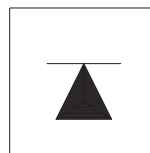

Lifting point — Located on the lift bale.

J-SERIES TROWEL — INSTRUCTIONS

Putting Into Service

Before packing and shipping, this Power Trowel was run and tested at the factory. If there are any problems, please let us know. Fill out and send the warranty-registration card supplied with the machine. All warranties are void unless this card is on file with us.

Before putting your new finisher into service, read all manuals and instructions carefully. Improper setup, use or maintenance of your equipment could result in personal injury or damage to equipment.

The purpose of this section of the manual is to explain the intended setup, use and maintenance of this equipment.

Assembly

Note: READ THESE INSTRUCTIONS CAREFULLY BEFORE ATTEMPTING TO ASSEMBLE ANY COMPONENTS.

HANDLE ASSEMBLY — QUICK PITCH™

The QUICK PITCH handle is spring loaded, personal injury or damage could result from improper handling or installation. Attach the handle tube as shown (Step 1). Bolts are to be inserted from the bottom side of the handle. Note that the bolt on the engine side must have a washer between the gearbox and the nut. The

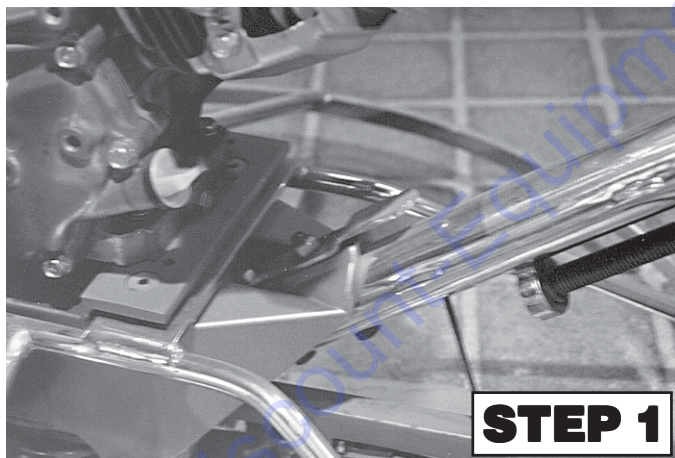

second bolt carries the auxiliary lift handle bracket in the place of a washer.

After the handle is connected to the trowel, grasp the QUICK PITCH control from operator's position. Pull the adjustment trigger on the QUICK PITCH handle and push the entire handle towards the engine as far as possible (Step 2). This will compress the spring inside the handle. Considerable force may be required to do this! Release the trigger to lock the spring in this compressed position.



Remove one brass nut from the cable end. Thread the second brass nut towards the cable as far as possible (Step 3). Insert the cable end into the yoke as shown. Replace the brass set nut on the cable end. Tighten the set nut by hand as far as possible to remove slack from the cable (Step 4). Using a wrench, tighten the locking nut on the other side of the boss to lock the cable in place (Step 5).



J-SERIES TROWEL — INSTRUCTIONS



Preload adjustment for QUICK PITCH

After the handle is installed on the machine, spring preload adjustment will be required. Locate the adjustment screw on the underside of the handle. A decal has been placed there to assist in the adjustment. Turn the screw to adjust until it lines up with the arrow on the decal matching your setup. Test pitch control operation. Adjust if necessary.



If you want to be able to increase the blade pitch using less arm force, adjust the block away from the gearbox. Be aware, this will also require more force to decrease the blade pitch. If you want to be able to decrease the blade pitch using less arm force, adjust the block toward the gearbox.

HANDLE ASSEMBLY — STANDARD HANDLE

Turn the pitch adjustment knob (located on the operator end of the handle) counter-clockwise until resistance is felt.

Attach the handle tube to gearbox as shown in the QUICK PITCH handle installation. Bolts are to be inserted from the bottom side of the handle. Note that the bolt on the engine side must have a washer between the gearbox and the nut. The second bolt carries the auxiliary lift handle bracket in the place of a washer.



Remove one brass nut from the cable end. Thread the second brass nut towards the cable as far as possible. Insert the cable end into yoke as shown in the QUICK PITCH installation. Replace the brass set nut on the cable end. Tighten the set nut by finger as far as possible to remove slack from the cable. Using a wrench, tighten the locking nut on the other side of the boss to lock the cable in place.

SAFETY KILL WIRE

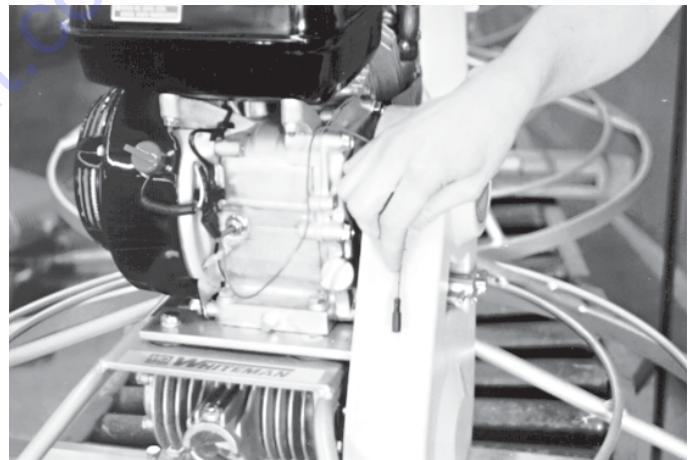

Locate the red wire protruding from the handle tube and connect it to the red wire tail on the engine. Test to insure proper operation!

HANDLE HEIGHT ADJUSTMENT

If handle height adjustment is desired, a handle wedge kit can be purchased for your machine by ordering Part Number 2576 from your Multiquip Discount-equipment. These wedges are placed between the handle and the gearbox to adjust the operating height of the handle. This kit comes complete with wedges, new bolts and installation instructions. This will move your operating handle position up or down approximately 3" (76mm).

THROTTLE CABLE INSTALLATION

Note: A red wire piece has been placed on the engine throttle assembly to show where the throttle cable from your handle should be placed.

J-SERIES TROWEL — INSTRUCTIONS

General Instructions

Set the throttle lever to the idle position by pushing it away from the operator's position towards the engine (counter clockwise from the top- Step 1). Loosen the screw that crimps the throttle cable to allow free movement of throttle cable (Step 2).



On Robin engines, the hook on the engine end of the throttle wire must be removed. Make the cut as shown (Step 3). The rest of the engine will not require this modification to the throttle cable.



Connect the throttle cable to the engine. Keep in mind there should be a piece of wire installed on the machine to show you where to route the throttle cable. When connecting the cable housing, make sure that no more than 1/4" (6.4mm) of the cable housing protrudes past the housing clamp on the engine (Step 4). After the cable has been installed on the engine, tighten the clamp on the throttle control, operator position of the handle to lock the throttle cable at the proper length.

These are general instructions. Installation of the throttle cable may vary for different engine configurations. Please look for more detailed instructions inside the box containing the handle. These more detailed instructions should provide adequate guidance for installing.

J-SERIES TROWEL — INSTRUCTIONS

Handling

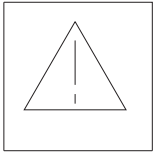

Machine is heavy and awkward to move around. Use proper heavy lifting procedures and **DO NOT LIFT THE MACHINE BY GUARD RINGS.**

Moving the Machine

Auxiliary Lifting Tube

Remove the auxiliary lifting tube located on top of the main handle. Insert the tube into the socket located on the opposite side of the gearbox from the handle. Make sure that the hole in the tube engages with the pin in the socket. With one person lifting from the main handle, and another lifting from the auxiliary lifting tube pick up the machine to move it, as shown in the following diagram.

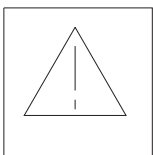
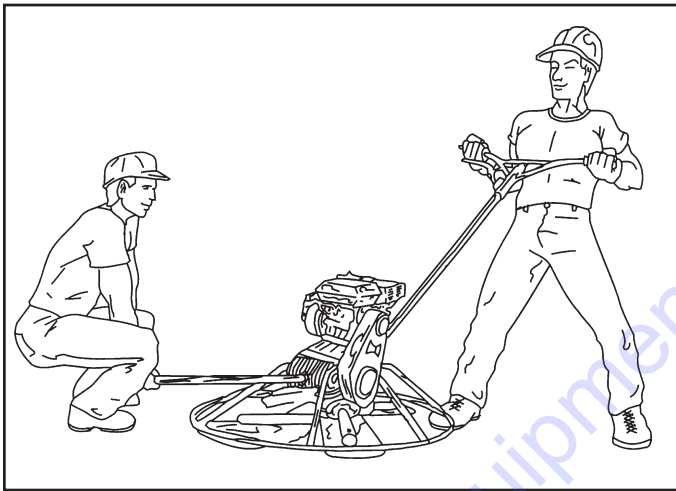

Caution! The machine must be stabilized by the person carrying the operator's handle. If it is not stabilized properly by this person it will rotate upside down.

Lift Bale

The lift bale is optional on new machines. It provides an optimal lift point for moving the finisher. Lift bales can be used to lift a machine up onto a building with a crane. They can also be used to lift a machine up onto a slab with a forklift machine. Using a crane to move a machine with a lift bale is highly recommended, and is perfectly safe for the machine. Extra care should be taken when lifting the machine off the ground, though. Serious damage to the machine or personal injury could be caused by dropping a finisher. See "Optional Equipment" in this manual for ordering information.

Machine Operations

CONTROLS

Safety Kill Switches

Your Whiteman finisher has been equipped with a safety kill switch or a hand operated clutch. Safety kill switches should be tested every time the engine is started.

Note: NEVER disable or disconnect the kill switch. It is provided for operator safety. Injury may result if it is disable, disconnected or improperly maintained.

Centrifugal Type

This is a red switch located on the main handle tube. The switching mechanism should operate freely and should be kept in this condition. With the switch in the OFF position, the engine should not start or run. The purpose of this switch is to stop the engine in a runaway situation, (i.e. the operator releasing the handle during operation).



Hand Clutch

Some finisher models are equipped with a hand operated clutch. These units are not equipped with a safety kill switch since the unit automatically stops rotating when the clutch lever is released. Clutch operation should be tested each time the machine is started.

Do not let the machine sit unused with the engine at high speed for an extended period of time. It will cause premature belt wear or may destroy the belt. Always set the engine speed to idle when the hand clutch is disengaged.

J-SERIES TROWEL — INSTRUCTIONS

Blade Pitch — Standard Handle

The pitch control on machines equipped with the standard handle is a big star-wheel knob located at the operator end of the main handle tube. Pitch is controlled by turning the knob. Clockwise for increased blade pitch, counter-clockwise for decreased blade pitch.



Blade Pitch — QUICK PITCH™ handle

Pitch is controlled on machines with this option by a T-shaped lever located on the top of the main handle tube. To change the blade pitch, pull the locking control up to the T-handle. Pulling the handle towards the operator will increase blade pitch. Pushing the handle away from the operator will decrease the blade pitch. See page 8 for adjustment.

Electric Control Switch (electric motors only)

Located on the control handle, this switch transfers power to the electric motor when grasped.

Electric On-Off Switch (electric motors only)

Located on the handle, it is the main power control switch.

Engine Operation

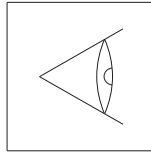

Check the oil level before starting the engine. Because of the number of engine options, please refer to engine owner's manual for specific instructions regarding engine operation.

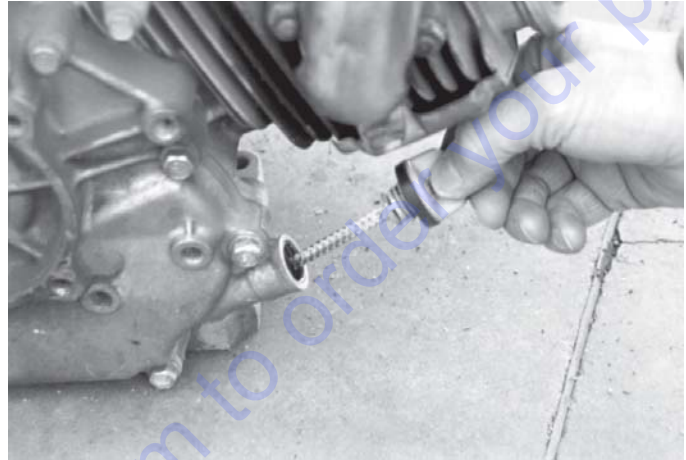

Gearbox Oil Level

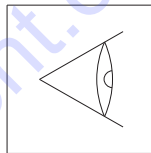

Check the gearbox oil level daily.

Check the gearbox oil level by removing the plug located on the side of the gearbox. It will be clearly marked by the "check" decal (see Machine Decals section). Take care when removing plugs on the gearbox, there are two of them. Removal of the bottom-most plug (DRAIN PLUG) will drain the oil. The level should be up to the bottom of the fill plug hole, located approximately half way up the side of the gear box. If needed, refill with specifically formulated Whiteman gearbox lubricant (P>N> 10139) or ISO 680 oil.

Operation

The following steps are intended as a basic guide to machine operation, and are not to be considered a complete guide to concrete finishing. We suggest that all operators (experienced and novice) read "Slabs on Grade" published by the American Concrete Institute, Detroit, Michigan. Read the "Training" section of this manual for more information.

1. Check oil levels in the engine and gearbox.
2. Check to make sure that the fuel control valve is on and fuel is in the tank.
3. Set safety kill switch (if equipped with centrifugal type clutch) to ON position.
4. Set throttle to idle position.

J-SERIES TROWEL — INSTRUCTIONS



NEVER start the engine with the throttle above the idle position.

5. Grasp the control handle with left hand. Pull slowly on starter rope until resistance is felt, then pull briskly to start the engine. If the engine fails to start after several tries, consult the engine owner's manual.
6. After the engine starts, let it warm up by idling for a few minutes.
7. Test the safety kill switch. If you have the centrifugal type clutch, try momentarily switching the kill switch to the OFF position. If your safety kill switch is working properly, the engine on your finisher should stop.
8. Get into the operator's position behind the handle. With a secure foothold and a firm grasp on the handles slowly increase the engine speed until the desired blades speed is obtained. If your finisher has a hand clutch, set your engine speed with the throttle, then pull on the hand clutch lever to start the blades. Adjust the blade speed after the hand clutch is fully engaged.
9. To maneuver the machine, gently lift up on or press down on the main trowel handle. To move the machine to the operator's left-lift up on the handle, to move machine to the right-push down on the handle.
10. The best method for finishing concrete is to slowly walk backwards with the machine, guiding the machine from side to side as you do so. See the diagram in the "Whiteman Suggested Training Checklist" at the end of this manual.

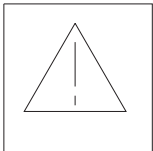

Always look behind you to avoid hazards before moving backwards.

Cleanup

NEVER allow concrete to harden on the power trowel.

Immediately after use, wash any concrete off your trowel with water. Be careful not to spray water on the engine. An old paintbrush or broom may help loosen any concrete that has started to harden.

Coat the blades and blade arms with diesel fuel after cleaning. This should help prevent rusting and allow for easier cleanup in the future.

Maintenance (Service, Adjustment and Repair)

Note: See the engine manual supplied with your machine for appropriate engine maintenance schedule.

There is a "Daily Preoperation Check List" at the end of this manual. Please feel free to make copies of it and use it on a daily basis.

Maintenance Schedule

Daily (8-10 Hours)

Check the fluid levels in the engine and gearbox.

Weekly (50-60 Hours)

Relube arms, thrust collar and clutch.

Replace the blades if necessary.

Check and clean or replace the engine air filter as necessary.

Monthly (200-300 Hours)

Remove, clean, reinstall and relube the arms, thrust collar and clutch.

Adjust the blade arms.

Yearly (2000-2500 Hours)

Check and replace if necessary the arm bushings, thrust collar bushings, shaft seals and belts.

Check pitch control cable for wear.

SERVICE PROCEDURES

Checking Belt Tension

The first indication of belt wear is a reduced blade speed despite the engine running at full speed. Inspect belts often for signs of damage or excessive wear.

There is no method for manual adjustment of belt tension. Excessively worn belts must be replaced.

Blade Pitch Adjustment Procedure

The maintenance adjustment of blade pitch is an adjustment that is made by a bolt on the arm of the trowel blade finger. This bolt is the contact point of the trowel arm to the lower wear plate on the spider. The goal of adjustment is to promote consistent blade pitch.

There are some things to look for when checking to see if adjustment is necessary. Is the machine wearing out blades unevenly (i.e. one blade is completely worn out while the others look new)? Does the machine have a perceptible rolling motion? Look at the machine while it is running, do the guard rings "rock up and down" relative to the ground? These are some indications that the blade pitch needs to be adjusted.

J-SERIES TROWEL — INSTRUCTIONS

The easiest way to make this adjustment is to use the Trowel Arm Adjustment Fixture, Part Number 1817 (pictured below) that is manufactured by Whiteman. This fixture will allow consistent adjustment of the trowel arm fingers. It comes with all the hardware necessary to properly accomplish this maintenance and instructions on how to properly utilize this tool. Adjusting the trowel arm fingers without a fixture requires a special talent.

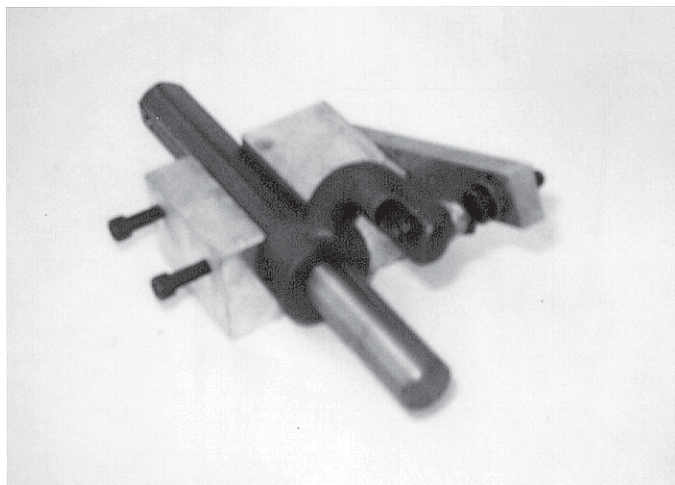

If a trowel arm adjustment fixture is not available and immediate adjustment is necessary, we suggest the following procedure. If you can see or feel which blade is pulling harder, adjust the bolt that corresponds to that blade. Another way to determine which blades need adjusting is to place the machine on a flat surface and pitch the blades as flat as possible. Now, look at the adjustment bolts. They should all barely make contact with the lower wear plate on the spider. If you can see that one of them is not making contact, some adjustment will be necessary.

It is possible to either adjust the “high” bolts down to the level of the one that is not touching, or adjust the “low” bolt up to the level of the higher ones. Verify that after adjustment, the blades will pitch correctly. Often times, if the blades are incorrectly adjusted, they will not be able to pitch flat. This is due to the adjusting bolts being raised too high. Conversely, some times the adjusting bolts are too low and the blades cannot be pitched enough.

Changing a Blade

Whiteman recommends that all the blades be changed at the same time. The machine may wobble or bounce if only some of the blades are changed at one time.

1. Place the machine on a flat, level surface. Adjust the blade pitch control to make the blades as flat as possible. Note the blade orientation on the trowel arm.

2. Remove the bolts and lock washers on the trowel arm, then remove the blade.
3. Scrape all concrete particles from the trowel arm.
4. Install the new blade, maintaining the proper orientation for direction of rotation.
5. Affix the bolts and lock washers.
6. Repeat steps 2-6 for all of the remaining blades.

Hand Clutch Adjustment

Some Whiteman finishers are equipped with a hand-operated clutch instead of an automatic centrifugal clutch. Two types of hand clutches have been installed. Both are belt-tightener type clutches. They operate by removing slack in the V-belt which then transmits power from the engine to the gearbox.

There are two reasons to adjust the hand clutch: 1) operator comfort; 2) initial belt stretch and break-in.

The easiest and most simple adjustment is to adjust the clutch cable housing using the adjusting nut located on the clutch lever. Rotating the nut provides either more or less (depending upon the direction of rotation) clutch engagement.

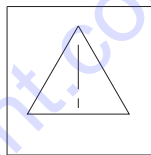

Always check to verify that the clutch will properly disengage!

For operator comfort: start the trowel following the instruction given earlier in this manual. Move the throttle lever so that the engine is running about 1/4 to 1/3 of full speed. Grip the trowel handle firmly and carefully engage the clutch by squeezing the clutch lever toward the handle with your left hand. After the trowel is stabilized and you feel comfortable with its operation, use your right hand to adjust the housing adjustment nut. Rotating the nut so that it backs out of the lever housing increases the engagement and also the squeezing force required to keep it engaged. Too much squeezing force may cause premature hand fatigue. Too little squeezing force may cause belt slippage and premature belt wear. Each operator should experiment with the adjustment to get the optimum combination of squeeze force and belt grip.

After initial break-in (approximately 8 hours) the above procedure should be repeated to attain optimum operator comfort and belt wear.

After considerable belt wear, the adjustments mentioned above may have a little or no effect on clutch engagement. If this is the case, the belt should be replaced.

J-SERIES TROWEL — TROUBLESHOOTING

TROUBLESHOOTING

SYMPTOM	POSSIBLE PROBLEM	SOLUTION
---------	------------------	----------

Engine running rough or not at all.

Kill switch off or malfunctioning? Make sure that the kill switch is on or replace switch if necessary.

Other problems? Consult engine manufacture's manual.

Safety kill switch not functioning.

Loose wire connections? Check wiring. Replace switch if necessary.

Bad contacts? Replace switch.

Clutch slipping or sluggish response to engine speed change.

Worn belts? Replace.

Dirty centrifugal clutch? Disassemble and clean the clutch.

Worn out centrifugal clutch? Replace entire clutch.

Hand clutch out of adjustment? Adjust as per instructions in Maintenance section.

Worn hand clutch parts? Replace parts as necessary.

Worn bearings in gearbox? Rotate input shaft by hand. If it rotates with difficulty check the input and output shaft bearings. Replace if necessary.

Worn or broken gears in gearbox? Check in particular to verify that the gearbox output shaft rotates when the input shaft is rotated. Replace both worm and worm gear as a set.

If trowel "bounces, rolls concrete, or makes uneven swirls in concrete".

Blades? Make certain blades are in good condition, not excessively worn. Finish blades should measure no less than 2" (50 mm) from the blade bar to the trailing edge, combo blades should measure no less than 3-1/2" (89mm). Trailing edge of blade should be straight and parallel to the blade bar.

Spider? Check that all blades are set at the same pitch angle as measured at the spider. A field adjustment tool is available for height adjustment of the trowel arms (see Optional Equipment section).

Bent trowel arms? Check the spider assembly for bent trowel arms. If one of the arms is even slightly bent, replace immediately.

Trowel arm bushings? Check the trowel arm bushing for tightness. This can be done by moving the trowel arms up and down. If there is more than 1/8" (3.2mm) of travel at the tip of the arm, the bushings should be replaced. All bushings should be replaced at the same time.

Thrust collar? Check the flatness of the thrust collar by rotating it on the spider. If it varies by more than 0.02" (0.5mm) replace the thrust collar.

Thrust collar bushings? Check the thrust collar by rocking it on the spider. If it tilts more than 1/16" (1.6mm) (as measured at the thrust collar O.D.), the bushing in the thrust collar should be replaced.

Thrust bearing worn? Check the thrust bearing to see that it is spinning free and has not worn into the thrust cap. Replace if necessary.

Machine has a perceptible rolling motion while running.

Main shaft? The main output shaft of the gearbox assembly should be checked for straightness. The main shaft must run straight and cannot be more than 0.003" (0.08mm) out of round at the spider attachment point.

Blade pitch? Check blades for consistent pitch. Adjust per Maintenance section instructions if necessary.

Operator Training

SUGGESTED TRAINING

Note: ONLY QUALIFIED AND EXPERIENCED PERSONNEL SHOULD OPERATE THIS EQUIPMENT

Before taking your new equipment to the job site for its first use, there are a few things that should be considered before operation.

Handling

Know how to transport your trowel properly. Keep in mind that you will need to place your trowel on a slab of concrete in the middle of construction area. How will you accomplish this? Do you need any special equipment for lifting or transport? These are questions that you should be able to answer.

Operation

Perhaps it would be wise to familiarize yourself with machine operation before placing your machine on a slab. It would be of use to understand how your trowel will behave and how it is controlled. The best way to do this is to test run your machine.

To test run your machine, place it on a flat piece of existing finished concrete. Before starting the machine, make sure that the area around the machine is clear of any obstructions and people. Test running your machine will give a good idea as to how the machine will operate under normal conditions. Keep in mind that running a machine on dry concrete could wear your blades at an accelerated rate.

Training Checklist

For proper operator training please use the attached sheet OPERATOR TRAINING CHECKLIST. It is located at the end of this manual. This sheet will list some of the minimums for basic operation of the machine. Please feel free to detach it and make copies. This sheet is a checklist by which an experienced operator can provide training to a new operator. This sheet should help to familiarize the new operator with the machine. It covers basic machine controls and use, but it is not to be considered a complete training exercise. Nor is it to be considered a complete guide to concrete finishing.

J-SERIES TROWEL — OPTIONAL EQUIPMENT

BLADES

Note: BLADES SHOULD BE CHANGED WHEN THEY FAIL TO FINISH CONCRETE IN A SATISFACTORY MANNER.

Blades are a vital part of finishing concrete. This Whiteman finisher has been designed to finish concrete with Whiteman and are built to stringent quality standards out of the finest trowel steel. If you need replacement blades, consult your parts list in this manual for part numbers and order them from Discount-equipment.

Combo Blades

This trowel was equipped with combination FLOAT/FINISH blades as original equipment. These blades have been designed for optimum performance in both the floating and finishing operations. These blades are versatile and should take care of most troweling needs.

Finish Blades

These blades have been specifically designed for finish operations with this trowel. They will provide a premium surface finishing capability from your trowel. They should only be used after the concrete has set to the point where the machine does not sink into the concrete when placed on it .

Clip-On Float Blades

These blades will clip on to an existing installed blade, allowing your finisher to float on “wet” concrete so that the troweling operation can begin as early as possible. They are easily removable, so that after the floating operation, when the concrete is sufficiently cured, they can be removed to expose the finish blades for continued troweling.

Float Discs

These round discs attach to the spiders and allow the machine to “float” on “wet” concrete. The disc design allows early floating and easy movement from wet to dry areas. They are also quite effective in embedding large aggregates and surface hardeners.

FIELD TROWEL ARM ADJUSTMENT TOOL

If blades show uneven wear patterns or some tend to wear out faster than others, the trowel arms may need to be adjusted. Whiteman makes a special tool that will adjust all of the trowel arms consistently, Part Number 1817-Trowel Arm Fixture.

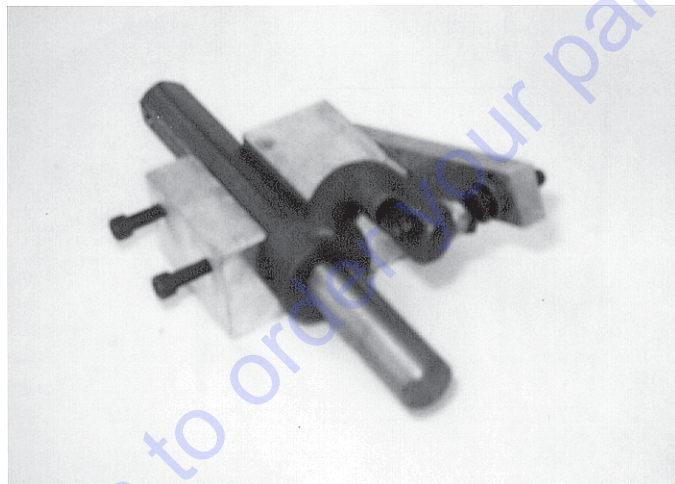

Shown here is the adjustment fixture with an arm. As each arm is locked into the fixture, the arm bolt is adjusted to where it contacts a stop on the fixture. This will consistently adjust all of the trowel arms, keeping the finisher as flat and evenly pitched as possible. See Blade Pitch Adjustment Procedure in the Maintenance section of this manual for more information.

LIFT BALE

There is a heavy duty, center balance type lifting bale made specifically for your trowel. These bales are ideal for lifting and transporting your trowel. They are designed to lift the finisher and balance it on it's center of gravity, providing great stability while lifting.

GRINDING ATTACHMENTS

Available grinding attachments are used for grinding surface imperfections or joints. These attachments allow greater utilization of your trowel.

J-SERIE TROWEL — TECHNICAL SPECIFICATIONS

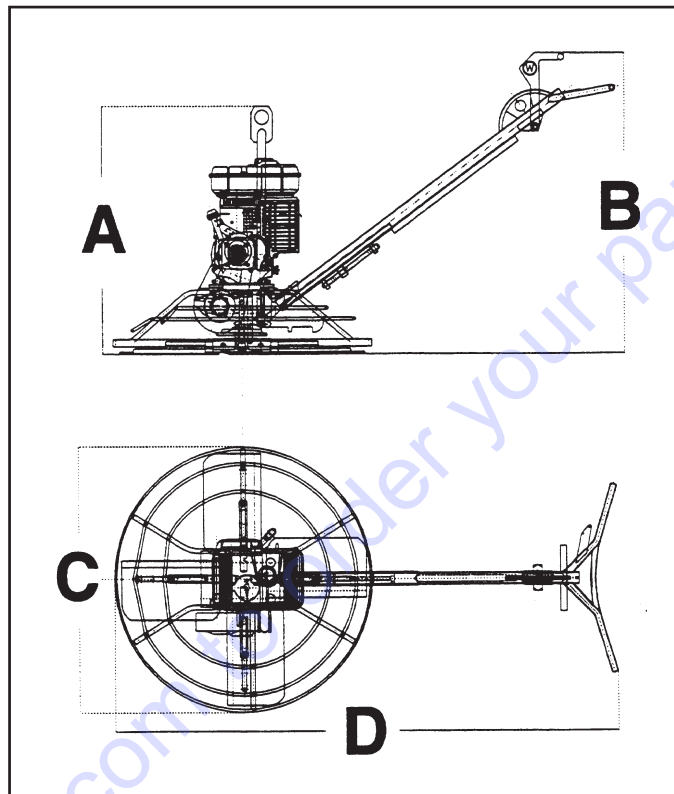

TECHNICAL SPECIFICATIONS

MODEL J B

A 36.7 in. 931.6mm 34.5 in. 876.2mm

B 41.4 in. 1044.2mm 41.1 in. 1044.2mm

C 36.5 in. 927.1mm 46 1168.4mm

D 70.5 in. 1789.4mm 75.2 in. 1910.1mm

Weight 150 lb. 330 Kg 240 lb. 528 Kg

Sound Pressure* 94 dB 94 dB 97 dB 97 dB

Vibration** 2.0g 19.6m/s² 2.5g 24.5 m/s²

Blade Speed (max.) 129 rpm @ 4000 129 rpm @ 4000 129 rpm @ 4000 129 rpm @ 4000

engine rpm engine rpm engine rpm engine rpm

Blade Tip Speed (max.) 1182pm 6.0 m/s 1478 fpm 7.5m/s

*Sound pressure is A weighted. Measured at the operator's ear position while running the machine on curing concrete in a manner most often experienced in "normal" circumstances. Sound pressure may vary depending upon the condition of the concrete. Hearing protection is always recommended.

**Vibration level indicated is the maximum RMS value obtained at the handle grip while operating the machine on curing concrete in a manner most often experienced in "normal" circumstances. Values were obtained from all three axes of motion. The values shown here represent the maximum RMS value from these measurements.

J-SERIES TROWEL — HANDLE

HANDLES ASSY.

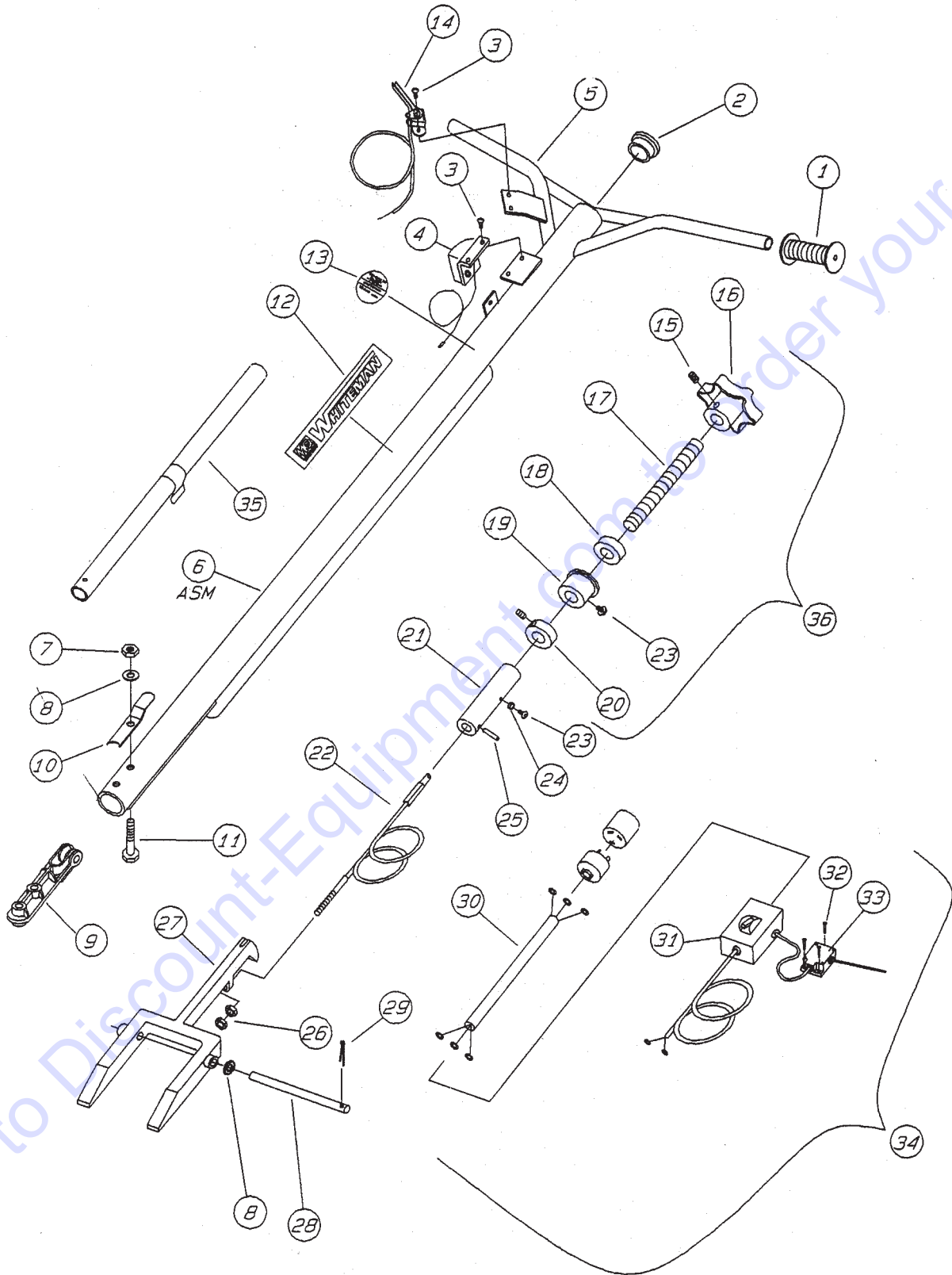

J-SERIES TROWEL — HANDLE

HANDLES ASSY.

<u>NO.</u>	<u>PART NO.</u>	<u>PART NAME</u>	<u>QTY.</u>	<u>REMARKS</u>
1	0189	HANDLE GRIP	2	
1	4634	HANDLE GRIP	2	ELECT.
2	1102	PLUG	1	
3	0304	RHMS 10- 24 X 1/4"	4	
4	1103	SAFETY SWITCH ASM	1	
5	1101	HANDLE ONLY	1	STANDARD
5	1907	HANDLE ONLY	1	ELECT.
5	9100	HANDLE ONLY	1	EXPORT
6	1100	HANDLE ASM.	1	SALES ITEM
6	1921	HANDLE ASM	1	ELECT.
7	10133	LOCK NUT 3/8- 16	2	
8	10136	FLAT WASHER 3/8"	4	
9	1117	SUPPORT BLOCK ASM (PULLEY & PIN)	1	
10	0190A	HOLDER	1	
11	1121	HHCS 3/8- 16 X 2.3/4	2	
13	1492	2.1/2" CHROME DECAL	1	
14	0302	THROTTLE CONTROL ASM.	1	
15	0185	SHSS 3/8- 16 X 3/8"	1	
16	0280B	HAND WHEEL	1	
17	1478	TROWEL CONTROL SHAFT	1	
18	0281	BEARING	1	
19	1111	BEARING	1	
20	3615	SET COLLAR (WITH SET SCREW)	1	
21	1113	SLIDE BLOCK & CABLE ASM.	1	
22	1115	CONTROL CABLE ASM.	1	STANDARD
22	9175	CONTROL CABLE ASM.	1	EXPORT
23	0786	BHCS 1/4- 20 X 3/8" NY- LOC	2	
24	0786A	SPACER	1	
25	1114	ROLL PIN 5/32 X 1.3/8"	1	
26	1116	BRASS JAM NUT 5/16- 18	2	
27	1150	YOKE ARM	1	
28	1151	YOKE PIN	1	
29	0683	COTTER PIN 3/32 X 3/4"	2	
30	2505	PIGTAIL ASM.	1	ELECT.
31	0175-1	SWITCH BOX	1	ELECT.
32	5044A	FHMS 10- 32 X 3/4"	3	ELECT.
33	1268	MICRO SWITCH	1	ELECT.
34	1189	SWITCH CONDUIT KIT	1	ELECT.
35		LIFT HANDLE ASM.	1	NO LONGER AVAILABLE
36	1110	TROWEL CINTROL ASM.	1	

J-SERIES TROWEL — QUICK PITCH HANDLE™

QUICK PITCH HANDLE ASSY.

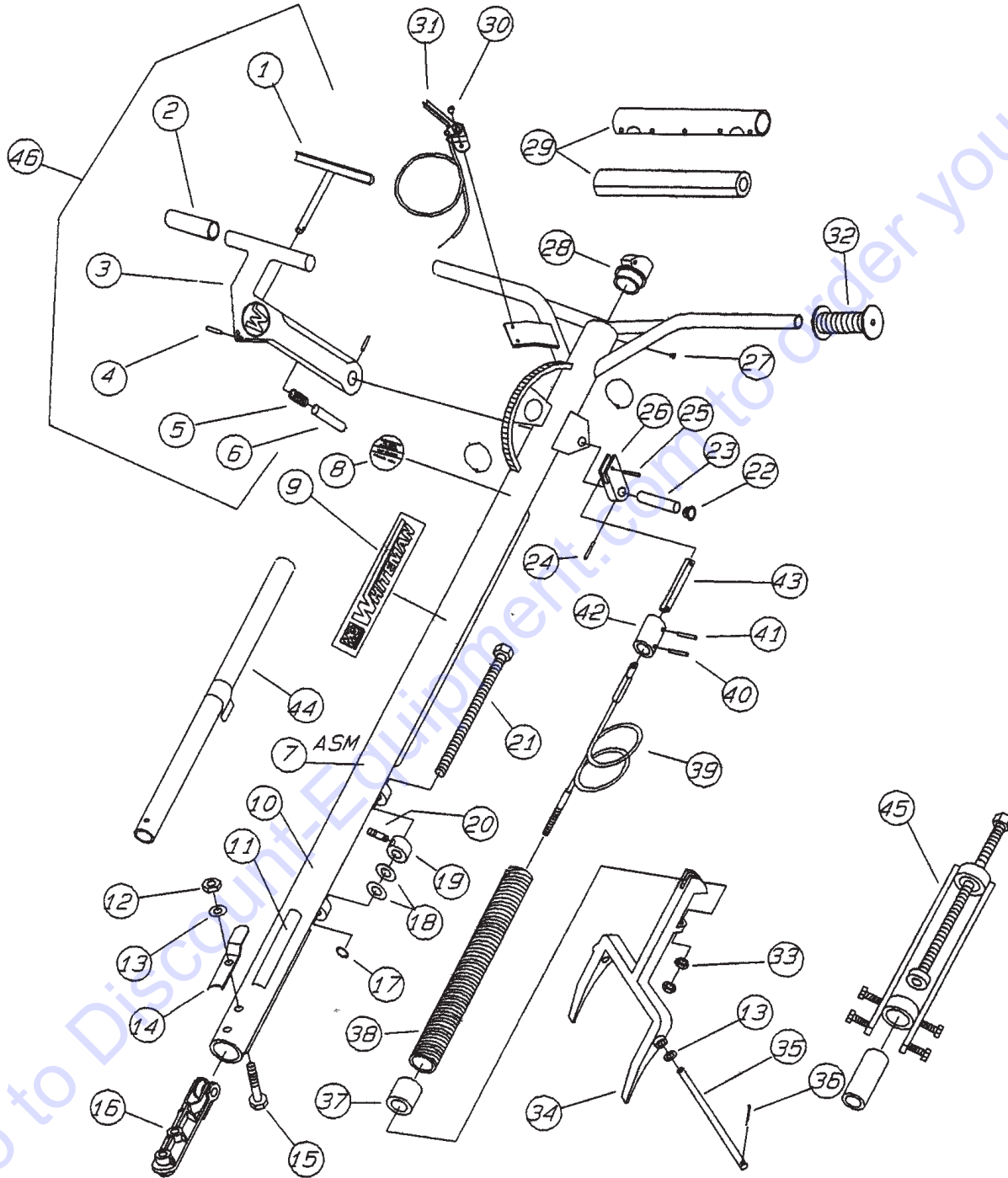

J-SERIES TROWEL — QUICK PITCH HANDLE™

QUICK PITCH HANDLE ASSY.

<u>NO.</u>	<u>PART NO.</u>	<u>PART NAME</u>	<u>QTY.</u>	<u>REMARKS</u>
1	1746	QUICK PITCH TRIGGER	1	
2	1724	CONTROL HANDLE GRIP	2	
3	1707	CONTROL HANDLE	1	INCLUDES 1739
	1739	NYLINER BUSHINGS	2	
	1734	WARNING DECAL		
4	1729	ROLL PIN 3/16 X 1.1/4"	3	
5	1706	LATCH RETURN SPRING	1	
6	1745	LATCHING SHAFT	1	
7	1700	HANDLE ASM. COMPLETE	1	SALES ITEM
8	1758	FINISHER HANDLE PATENT DECAL	1	
10	1701	HANDLE ONLY	1	
10	1721	HANDLE ONLY	1	
11	1735	PRE- LOAD DECAL	1	
12	10133	LOCK NUT 3/8- 16	2	
13	10136	FLAT WASHER 3/8"	4	
14	0190A	HOLDER	1	
15	1121	HHCS 3/8- 16 X 2.3/4"	2	
16	1117	SUPPORT BLOCK ASM.	1	
17	1737	SNAP RING	1	
18	1733	HARDENED WASHER 1/2" X 1/32"	2	
19	1718	PRE- LOAD ADJUSTMENT NUT	1	
20	1732	PRE- LOAD ADJUSTMENT PIN	1	
21	1717	PRE- LOAD ADJUSTMENT SCREW	1	
22	1719	PIVOT PLATE BUSHING	2	
23	1711	CONTROL SHAFT	1	
24	4568	ROLL PIN 3/16" X 1"	1	
25	1731	ROLL PIN 1/4" X 3/4"	1	SEE ITEM 47
26	1708	SLIDE CONTROL ARM	1	SEE ITEM 47
27	1743	PHSTS 1/4 X 1/2"	1	
28	1727	SAFETY SWITCH ASM.	1	
29	1730	HANDLE PAD & COVER	1	
30	0304	RHMS 10- 24 X 1/4"	2	
31	0302	THROTTLE CABLE ASM.	1	
32	0189	HANDLE GRIP	2	
33	1116	BRASS JAM NUT 5/16- 18	2	
34	1150	YOKE ARM	1	
35	1151	YOKE PIN	1	
36	0683	COTTER PIN 3/32" X 3/4"	2	
37	1716	PRE- LOAD ADJUSTMENT BLOCK	1	
37	1741	PRE- LOAD ADJUSTMENT BLOCK	1	
38	1715	CONTROL BALANCE SPRING	1	
39	1714	CONTROL CABLE ASM.	1	
39	9174	CONTROL CABLE ASM.	1	
40	1757	ROLL PIN 3/16" X 1.3/8"	1	
41	1726	ROLL PIN 1/4" X 1.3/8"	1	
42	1712	CONTROL CABLE SLIDE BLOCK	1	
43	1709	CONTROL ARM CONNECTOR	1	SEE ITEM 47
44		LIFT HANDLE ASM.	1	NO LONGER AVAILABLE
45	1749	TOOL ASM.FOR UNLOADING SPRING	1	SALES ITEM
46	1754	T-HANDLE ASSY.	1	

J-SERIE TROWEL — SPIDER AND BLADES

SPIDER & BLADES ASSY.

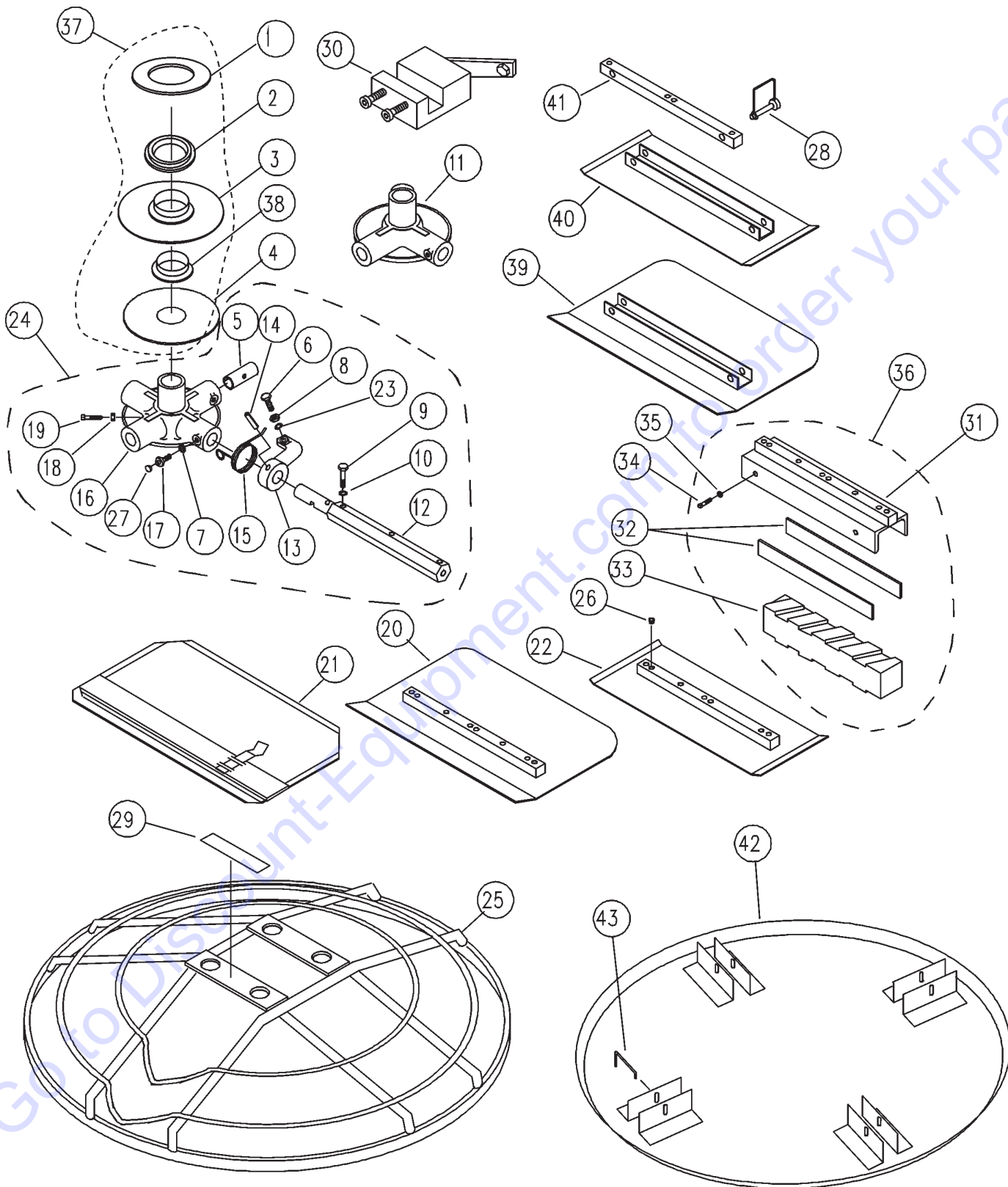

J-SERIES TROWEL — SPIDER AND BLADES

SPIDER & BLADES ASSY.

<u>NO.</u>	<u>PART NO.</u>	<u>PART NAME</u>	<u>QTY.</u>	<u>REMARKS</u>
1*	12208	WEAR RING	1	
2*	12778	FLANGE BEARING	1	
3*	10793	THRUST COLLAR	1	INCLUDES ITEMS W/#
4*	1154A	WEAR PLATE	1	
5	1157A	BEARING INSERT	3,4	
6	0164B	RADIUS HEAD 3/8- 16 X 1.1/4"	3,4	FULL THREAD
7	1875	INT. SHKP. WASHER 3/8"	3,4	
8	1876	JAM NUT 3/8- 16	3,4	CLASS 2B
9	0105	HHCS 5/16- 18 X 1.1/2"	6,8	
10	0161C	LOCK WASHER 5/16"	6,8	
11	1156	SPIDER PLATE ONLY	1	
12	2826	TROWEL ARM	3,4	
13	1163	TROWEL ARM LEVER	3,4	
14	4164	ROLL PIN 5/16 X 1.3/4"	3,4	
15	1316	SPRING (RIGHT HAND)	3,4	
16	1161	SPIDER PLATE ONLY	1	
17	1322	RETAINING SCREW ASM.	3,4	
18	1456	HEX NUT 3/8- 16	1	
19	1167A	SHSS 3/8- 16 X 1.1/2" CONE POINT	1	
20	10844	COMBINATION FLOAT & FINISH BLADE	3,4	SALES ITEM
21	0954F	FLOAT BLADE	3,4	SALES ITEM
22	0900	FINISH BLADE	3,4	SALES ITEM
22	10900	ENDURO FINISH BLADE	3,4	SALES ITEM
23	0166A	LOCK WASHER 3/8"	3,4	
24	1210	SPIDER PLATE ASM. (3 BLADE)		
24	1215	SPIDER PLATE ASM. (4 BLADE)		
25	2274	GUARD RING	1	
26	1434	TROWEL PLUG (FINISH BLADE ONL)	3,4	
27	1162A	LUBRA- CAP	3,4	
28	1869	SNAP PIN 1/4 X 1.3/4"	6,8	SALES ITEM
29	1940	GUARD RING DECAL	1	
30	1817	FIELD TROWEL ARM ADJUSTER ASM.	1	
31	0987	GRINDING ATTACHMENT HOLDER	1	
32	0988	LOCKING PLATE	2	
33	S- 986	GRINDING ATTACHMENT STONE	1	SALES ITEM
34	0414	SHSS 5/16- 18 X 3/4"	4	
35	0106	JAM NUT 5/16- 18		
36	0985	GRINDING ATTACHMENT ASM.	1	SALES ITEM
37	10968	THRUST BEARING KIT	1	INCLUDES ITEMS W/*
38*#	1471	THRUST COLLAR BUSHING	1	
39	1871	UNIVERSAL FIT COMBINATION BLADE	3,4	SALES ITEM
39	101871	ENDURO UNIVERSAL FIT COMBINATION BLADE	3,4	SALES ITEM
40	1872	UNIVERSAL FIT FINISH BLADE	3,4	SALES ITEM
40	101872	ENDURO UNIVERSAL FIT FINISH BLADE	3,4	SALES ITEM
41	1857	UNIVERSAL FIT MOUNTING BAR	3,4	SALES ITEM
42	2878	FLOAT DISK	1	SALES ITEM
43	2935	FLOAT DISK LATCH PIN	4	SALES ITEM

J-SERIES TROWEL — GEARBOX AND ENGINE MOUNTS

GEAR BOX & ENGINE MOUNTS ASSY.

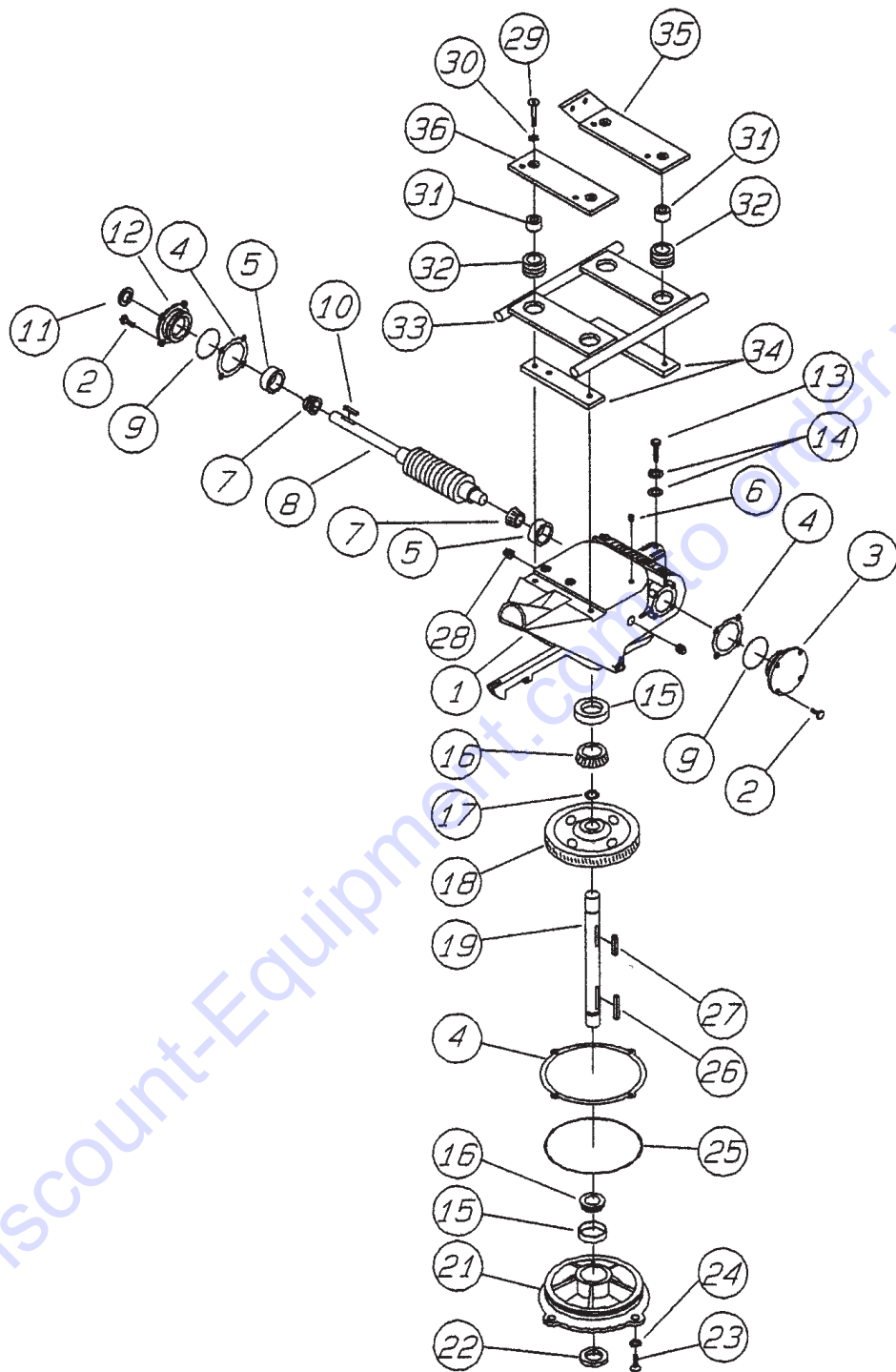

Ⓒ GEARBOX ASSEMBLY

REQ 20 OZ LUBRICATING OIL

J-SERIES TROWEL — GEARBOX AND ENGINE MOUNTS

GEAR BOX & ENGINE MOUNTS ASSY.

<u>NO.</u>	<u>PART NO.</u>	<u>PART NAME</u>	<u>QTY.</u>	<u>REMARKS</u>
1	1131	GEAR CASE	1	
2	0131A	HHCS 1/4- 20 X 3/4"	8	
3	1136	END CAP	1	
4	2614	GASKET/ SEAL KIT		ITEMS 9,11,22,& 25
5	0735A	BEARING CUP	2	
6	1132	AIR VENT	1	
7	0735	BEARING CONE	2	
8	1828	WORM & COUNTER SHAFT	1	
9	2308	O- RING	2	
10	0627	SQUARE KEY 3/16 X 3/16 X 1.1/4"	1	NOT IN ASM.
11	0753	OIL SEAL	1	
12	1133	FLANGE	1	
13	0655	HHCS 5/16- 18 X 3/4"	1	NOT IN ASM.
14	0300B	FLAT WASHER 5/16'	2	NOT IN ASM.
15	0232A	BEARING CUP	2	
16	0232	BEARING CONE	2	
17	1138	RETAINING RING	1	
18	1202	BRONZE GEAR	1	
19	2440	MAINSHAFT	1	
20	1200	GEAR BOX ASM.	1	
21	1145	COVER PLATE	1	
22	0254	OIL SEAL	1	
23	1146	FHSCS 5/16- 18 X 1"	4	
24	10235	EXT. SHKP. LOCK WASHER 5/16"	4	
25	1143	SEAL RING	1	
26	1238	WOODRUFF KEY #25	1	NOT IN ASM.
27	1139	WOODRUFF KEY # 21	1	
28	0121A	SQUARE HEAD PIPE PLUG 3/8"	1	
29	1481	FHSCS 3/8- 16 X 1.2/4"	4	ELECTRIC
30	1480	C' SUNK SHKP. WASHER 3/8"	4	
30	0166A	LOCK WASHER 3/8"	4	ELECTRIC
31	1245	SPACER	4	
32	1247	GROMMET	4	STATIONARY RING ONLY
33	1251	STATIONARY GUARD RING	1	
33	2274	STATIONARY GUARD RING	1	EXPORT
34	1816	PLATE	2	
35	1955	FRONT ENGINE MOUNT	1	ELECTRIC
35	1954	FRONT ENGINE MOUNT	1	GAS
36	1943	REAR ENGINE MOUNT	1	ELECTRIC
36	1942	REAR ENGINE MOUNT	1	GAS
	10139	GEARBOX OIL REPLACEMENT, AS REQ.		22 OZ. BOTTLE
	2616	BEARING REPLACEMENT KIT		ITEMS 3,5,7,15, & 16

J-SERIES TROWEL — ENGINES, 5 HP B&S, 6.0 HP ROBIN, 5.5 HP HONDA

ENGINES, 5 H.P. B&S, 6.0 H.P. ROBIN, 5.5 H.P. HONDA ASSY.

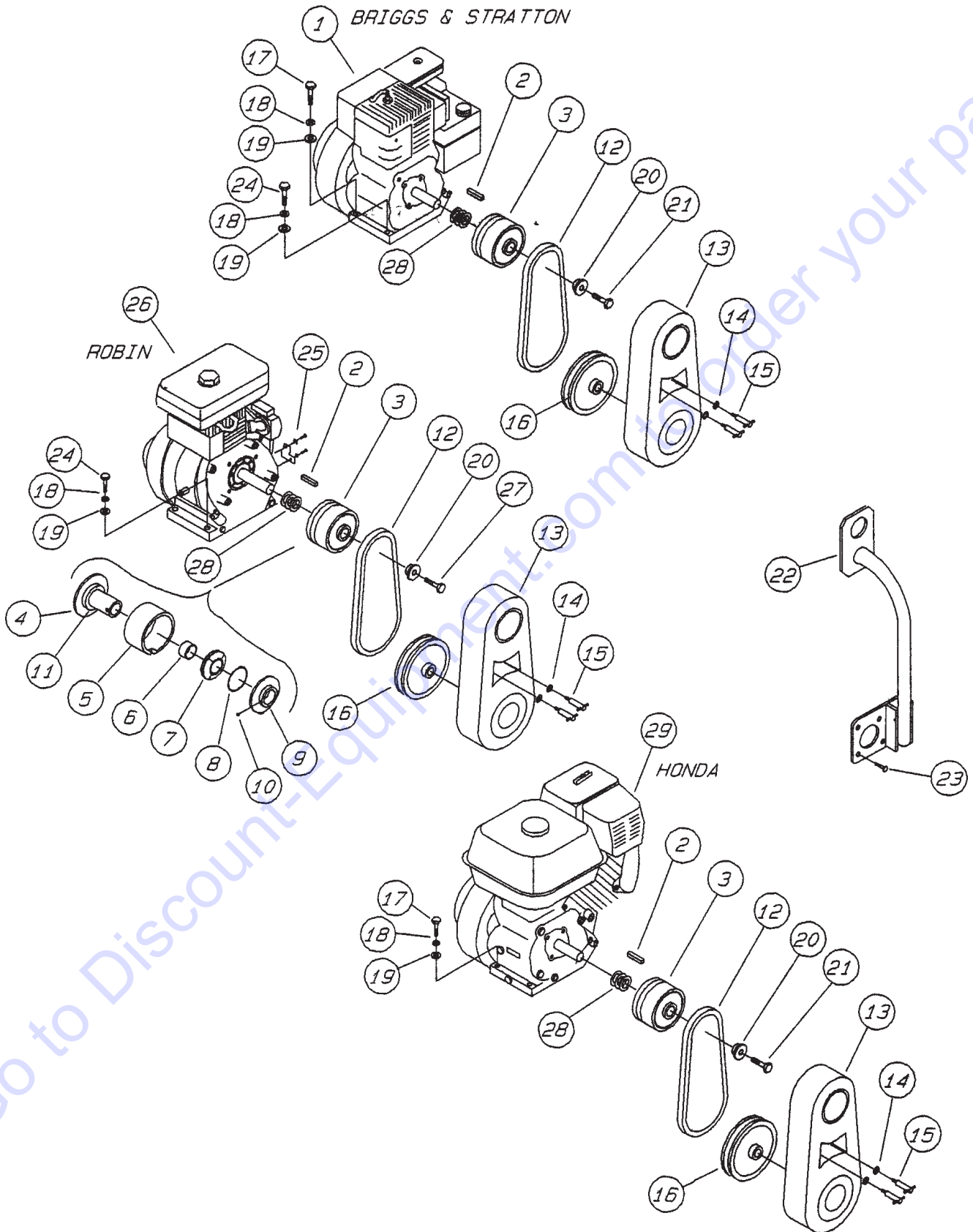

J-SERIES TROWEL — ENGINES, 5 HP B&S, 6.0 HP ROBIN, 5.5 HP HONDA

ENGINES, 5 H.P. B&S, 6.0 H.P. ROBIN, 5.5 H.P. HONDA ASSY.

<u>NO.</u>	<u>PART NO.</u>	<u>PART NAME</u>	<u>QTY.</u>	<u>REMARKS</u>
1		ENGINE 5 HP. B&S	1	
2	0627	SQUARE KEY 3/16 X 3/16 X 1.1/4"	1	
3	0255	AUTOMATIC CLUTCH ASM. 3/4" BORE	1	INCLUDES ITEMS W/@
4@	21307	SPINDLE 3/4" BORE	1	REPLACES P/N 0256
5@	0251	CLUTCH HOUSING DRUM	1	INCLUDES ITEM 6
6@	0458	CLUTCH HOUSING DRUM BUSHING	1	
7@	B1766	WEIGHT, CLUTCH	1	REPLACES P/N 0454
8@	0855	SPRING	1	
9@	0253	CLUTCH EXPANSION PLATE	1	
10@	1868	SHSS 3/8- 24 X 3/4"	1	
11@	0456	BELT RUNNER (BEARING)	1	
12	1390	BELT (A26)	1	HONDA, ROBIN
12	1243	BELT (A27)	1	B&S
13	1335	BELT GUARD	1	
14	0181B	LOCK WASHER 1/4"	2	
15	2577	T- BOLT 1/4- 20	2	
16	0740	PULLEY (4.95" O.D.)	1	
17	10181	HHCS 5/16- 24 X 1.1/4"	2,4	
18	0161C	LOCK WASHER 5/16"	4	
19	0300B	FLAT WASHER 5/16"	4	
20	1406	RETAINER	1	
21	1403	FHSCS 5/16- 24 X 1.1/4"	1	
22	1846	LIFTING BALE ASM.	1	SALES ITEM
23	1847	FHSCS 5/16- 24 X 3/4"	4	OPTIONAL
24	1391	HHCS 5/16- 24 X 1.1/2"	2	
25	2742	THROTTLE MOUNT	1	
26		ENGINE 6.0 HP. ROBIN	1	
27	1393	FHSCS 3/8- 24 X 1.1/2"	1	ROBIN
28	0939	SPACER (LIFTING BALE OPTION)	3	
29		ENGINE 5.5 HP. HONDA	1	

PARTS FINDER

**Search Website
by Part Number**



**Search Manual
Library For Parts
Manual & Lookup Part
Numbers – Purchase
or Request Quote**

Search Manuals

Enter your information to help us find the right parts manual for your equipment.

* Brand:

* Model:

* Serial:

* Part Number:

SEARCH

**Can't Find Part or
Manual? Request Help
by Manufacturer,
Model & Description**

Parts Order Form

Please fill in the following information to help us find the right part for your equipment.

Manufacturer:	<input type="text"/>
Model:	<input type="text"/>
Description:	<input type="text"/>
Part Number:	<input type="text"/>
Quantity:	<input type="text"/>
Notes:	<input type="text"/>

Submit

Discount-Equipment.com is your online resource for quality parts & equipment.

Florida: **561-964-4949** Outside Florida TOLL FREE: **877-690-3101**

Need parts?

Click on this link: <http://www.discount-equipment.com/category/5443-parts/> and choose one of the options to help get the right parts and equipment you are looking for. Please have the machine model and serial number available in order to help us get you the correct parts. If you don't find the part on the website or on one of the online manuals, please fill out the request form and one of our experienced staff members will get back to you with a quote for the right part that your machine needs.

We sell worldwide for the brands: Genie, Terex, JLG, MultiQuip, Mikasa, Essick, Whiteman, Mayco, Toro Stone, Diamond Products, Generac Magnum, Airman, Haulotte, Barreto, Power Blanket, Nifty Lift, Atlas Copco, Chicago Pneumatic, Allmand, Miller Curber, Skyjack, Lull, Skytrak, Tsurumi, Husquvarna Target, Stow, Wacker, Sakai, Mi-T-M, Sullair, Basic, Dynapac, MBW, Weber, Bartell, Bennar Newman, Haulotte, Ditch Runner, Menegotti, Morrison, Contec, Buddy, Crown, Edco, Wyco, Bomag, Laymor, EZ Trench, Bil-Jax, F.S. Curtis, Gehl Pavers, Heli, Honda, ICS/PowerGrit, IHI, Partner, Imer, Clipper, MMD, Koshin, Rice, CH&E, General Equipment, Amida, Coleman, NAC, Gradall, Square Shooter, Kent, Stanley, Tamco, Toku, Hatz, Kohler, Robin, Wisconsin, Northrock, Oztec, Toker TK, Rol-Air, APT, Wylie, Ingersoll Rand / Doosan, Innovatech, Con X, Ammann, Mecalac, Makinex, Smith Surface Prep, Small Line, Wanco, Yanmar