

# PARTS MANUAL



## **MODEL J3036H55 CONVERTIBLE EDGING WALK-BEHIND TROWEL**

**(HONDA GX160UT2QX2 GASOLINE ENGINE)**

Revision #2 (09/29/22)



THIS MANUAL MUST ACCOMPANY THE EQUIPMENT AT ALL TIMES.

**PN: 13413**

# PARTS FINDER

**Search Website  
by Part Number**



**Search Manual  
Library For Parts  
Manual & Lookup Part  
Numbers – Purchase  
or Request Quote**

**Search Manuals**

Enter your information to help us find the right parts manual for your machine.

\* Brand:

\* Model:

\* Serial:

\* Part Number:

SEARCH

**Can't Find Part or  
Manual? Request Help  
by Manufacturer,  
Model & Description**

**Parts Order Form**

Please fill in the following information to help us find the right part for your machine.

Manufacturer:	<input type="text"/>
Model:	<input type="text"/>
Description:	<input type="text"/>
Part Number:	<input type="text"/>
Quantity:	<input type="text"/>
Notes:	<input type="text"/>

Discount-Equipment.com is your online resource for quality parts & equipment.

Florida: **561-964-4949** Outside Florida TOLL FREE: **877-690-3101**

**Need parts?**

Click on this link: <http://www.discount-equipment.com/category/5443-parts/> and choose one of the options to help get the right parts and equipment you are looking for. Please have the machine model and serial number available in order to help us get you the correct parts. If you don't find the part on the website or on one of the online manuals, please fill out the request form and one of our experienced staff members will get back to you with a quote for the right part that your machine needs.

We sell worldwide for the brands: Genie, Terex, JLG, MultiQuip, Mikasa, Essick, Whiteman, Mayco, Toro Stone, Diamond Products, Generac Magnum, Airman, Haulotte, Barreto, Power Blanket, Nifty Lift, Atlas Copco, Chicago Pneumatic, Allmand, Miller Curber, Skyjack, Lull, Skytrak, Tsurumi, Husquvarna Target, Stow, Wacker, Sakai, Mi-T-M, Sullair, Basic, Dynapac, MBW, Weber, Bartell, Bennar Newman, Haulotte, Ditch Runner, Menegotti, Morrison, Contec, Buddy, Crown, Edco, Wyco, Bomag, Laymor, EZ Trench, Bil-Jax, F.S. Curtis, Gehl Pavers, Heli, Honda, ICS/PowerGrit, IHI, Partner, Imer, Clipper, MMD, Koshin, Rice, CH&E, General Equipment, Amida, Coleman, NAC, Gradall, Square Shooter, Kent, Stanley, Tamco, Toku, Hatz, Kohler, Robin, Wisconsin, Northrock, Oztec, Toker TK, Rol-Air, APT, Wylie, Ingersoll Rand / Doosan, Innovatech, Con X, Ammann, Mecalac, Makinex, Smith Surface Prep, Small Line, Wanco, Yanmar

# TABLE OF CONTENTS

## J3036H55 Convertible Edging Walk-Behind Trowel

Explanation of Code in Remarks Column.....	4
Suggested Spare Parts .....	5

## Component Drawings

Nameplate and Decals Assembly.....	6-7
Standard Handle Assembly .....	8-9
Quick-Pitch™ Handle Assembly.....	10-13
Guard Ring Assembly.....	14-15
Gearbox Assembly .....	16-17
Engine and Clutch Assembly.....	18-19
Spider Assembly.....	20-21
Engine Service Parts.....	22-23

### NOTICE

Specifications and part numbers are subject to change without notice.

# EXPLANATION OF CODE IN REMARKS COLUMN

The following section explains the different symbols and remarks used in the Parts section of this manual. Use the help numbers found on the back page of the manual if there are any questions.

## NOTICE

The contents and part numbers listed in the parts section are subject to change **without notice**. Multiquip does not guarantee the availability of the parts listed.

## SAMPLE PARTS LIST

NO.	PART NO.	PART NAME	QTY.	REMARKS
1	12345	BOLT .....	1	INCLUDES ITEMS W/%
2%		WASHER, 1/4 IN. ....		NOT SOLD SEPARATELY
2%	12347	WASHER, 3/8 IN. ...	1	MQ-45T ONLY
3	12348	HOSE .....	A/R	MAKE LOCALLY
4	12349	BEARING .....	1	S/N 2345B AND ABOVE

## NO. Column

**Unique Symbols** — All items with same unique symbol (@, #, +, %, or >) in the number column belong to the same assembly or kit, which is indicated by a note in the “Remarks” column.

**Duplicate Item Numbers** — Duplicate numbers indicate multiple part numbers, which are in effect for the same general item, such as different size saw blade guards in use or a part that has been updated on newer versions of the same machine.

## NOTICE

When ordering a part that has more than one item number listed, check the remarks column for help in determining the proper part to order.

## PART NO. Column

**Numbers Used** — Part numbers can be indicated by a number, a blank entry, or TBD.

TBD (To Be Determined) is generally used to show a part that has not been assigned a formal part number at the time of publication.

A blank entry generally indicates that the item is not sold separately or is not sold by Multiquip. Other entries will be clarified in the “Remarks” Column.

## QTY. Column

**Numbers Used** — Item quantity can be indicated by a number, a blank entry, or A/R.

A/R (As Required) is generally used for hoses or other parts that are sold in bulk and cut to length.

A blank entry generally indicates that the item is not sold separately. Other entries will be clarified in the “Remarks” Column.

## REMARKS Column

Some of the most common notes found in the “Remarks” Column are listed below. Other additional notes needed to describe the item can also be shown.

**Assembly/Kit** — All items on the parts list with the same unique symbol will be included when this item is purchased.

Indicated by:

“INCLUDES ITEMS W/(unique symbol)”

**Serial Number Break** — Used to list an effective serial number range where a particular part is used.

Indicated by:

“S/N XXXXX AND BELOW”

“S/N XXXX AND ABOVE”

“S/N XXXX TO S/N XXX”

**Specific Model Number Use** — Indicates that the part is used only with the specific model number or model number variant listed. It can also be used to show a part is NOT used on a specific model or model number variant.

Indicated by:

“XXXXX ONLY”

“NOT USED ON XXXX”

**“Make/Obtain Locally”** — Indicates that the part can be purchased at any hardware shop or made out of available items. Examples include battery cables, shims, and certain washers and nuts.

**“Not Sold Separately”** — Indicates that an item cannot be purchased as a separate item and is either part of an assembly/kit that can be purchased, or is not available for sale through Multiquip.

## SUGGESTED SPARE PARTS

### J3036H55 WALK-BEHIND TROWEL

1 to 3 Units

Qty.	P/N	Description
2	22762	HANDLE GRIP
1	21047	KIT, BEARINGS/SEALS
1	21046	KIT, SEALS
1	20285	PITCH CABLE (STD.)
1	20297	PITCH CABLE (Q.P.)
1	21243	KIT, THROTTLE
1	10968	KIT, THRUST BEARING
1	10567	THRUST PLATE
1	10639	WEAR PLATE
1	24386	WEAR PLATE, UPPER
2	30648	V-BELT, A26
2	20111	LUBRICANT, GEARBOX
1	30344	BELT GUARD
3	20856	SWITCH, CENTRIFUGAL STOP
4	1157 A	BUSHING, TROWEL ARM
4	30638	ASSY., TROWEL ARM

### HONDA GX160UT2QX2 GASOLINE ENGINE

1 to 3 Units

Qty.	P/N	Description
1	34150ZH7023	ALERT UNIT, OIL
1	17620Z4H900	CAP, FUEL TANK, CHROME
3	17210ZE1517	ELEMENT, AIR CLEANER
2	17218ZE1507	FILTER, OUTER FOAM
1	28462ZH8003	ROPE, RECOIL STARTER
1	28461Z4M305	KNOB, RECOIL STARTER
3	9807956846	SPARK PLUG, BPR6ES
1	15600Z0T810	CAP ASSY., OIL FILLER

#### NOTICE

Part numbers on this Suggested Spare Parts list may supersede/replace the part numbers shown in the following parts lists.

# NAMEPLATE AND DECALS ASSY.

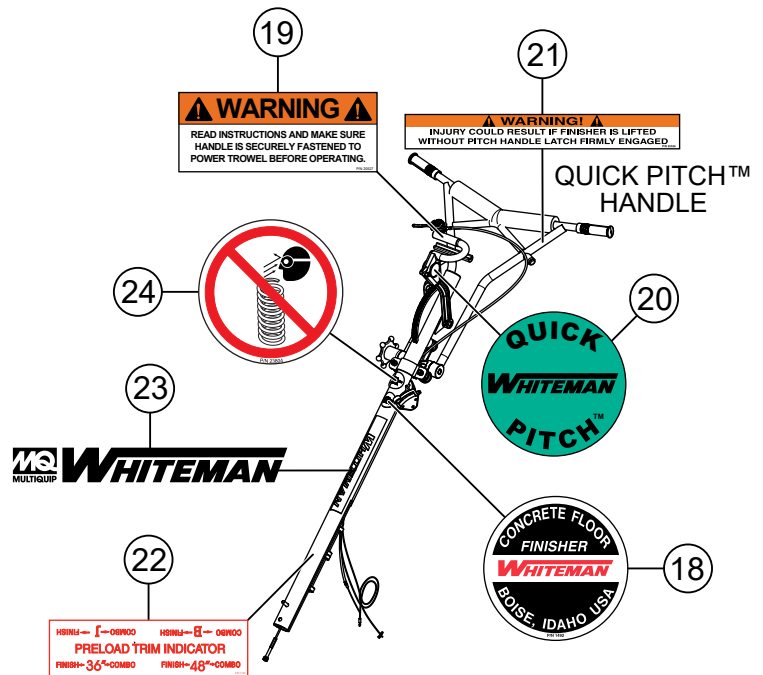
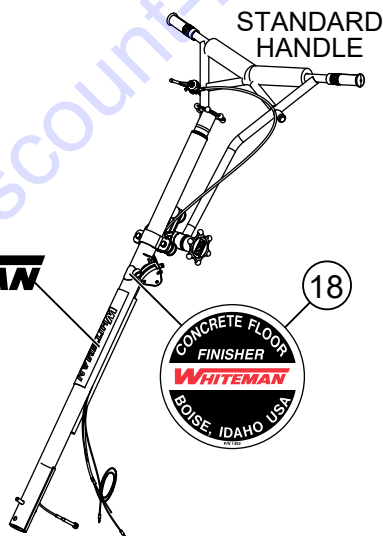
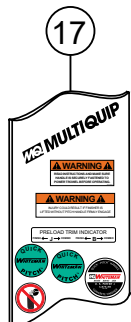
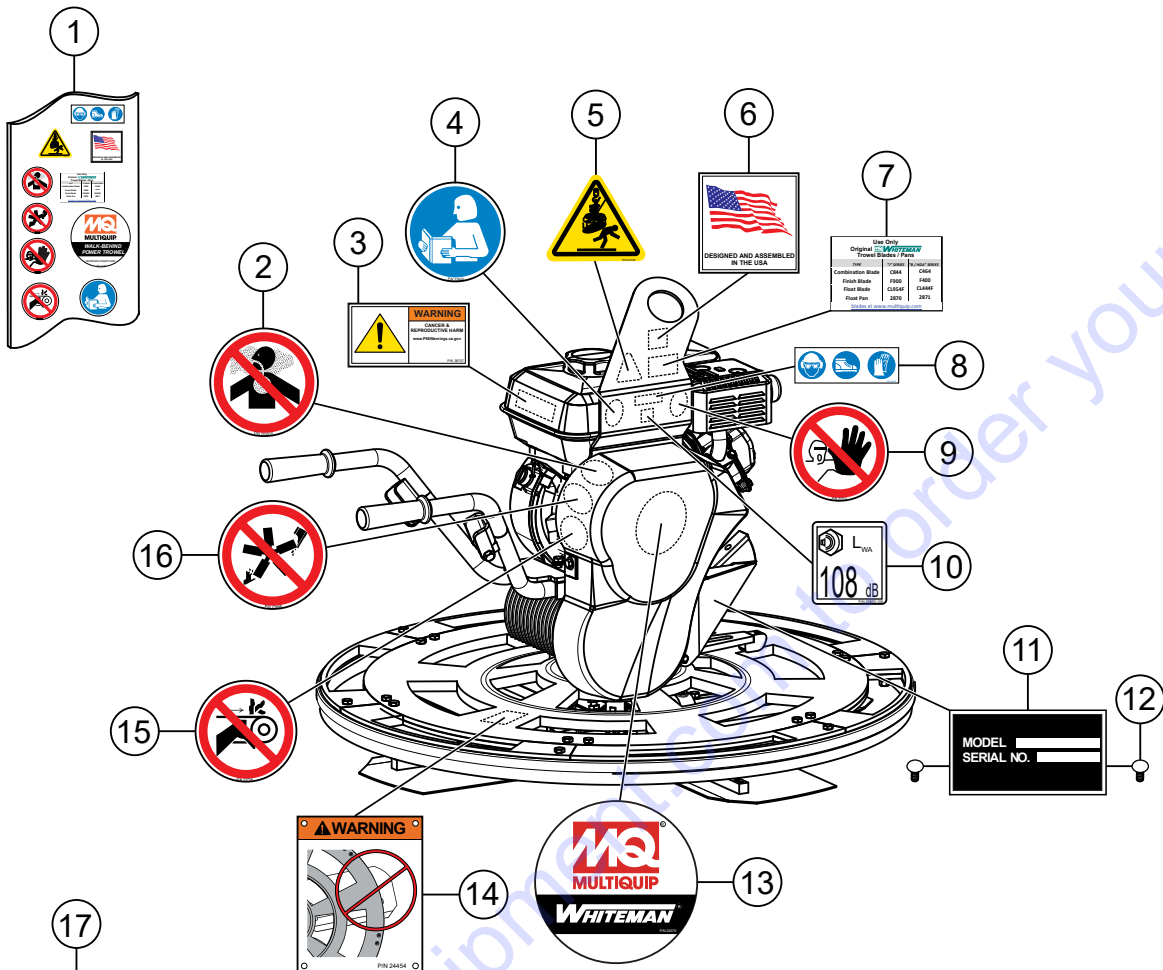

## NAMEPLATE AND DECALS ASSY.

<u>NO.</u>	<u>PART NO.</u>	<u>PART NAME</u>	<u>QTY.</u>	<u>REMARKS</u>
1	30651	DECAL KIT, J AND B FINISHERS.....	1.....	INCLUDESITEMSW/#
2#	23810	ISO DECAL, INHALATION HAZARD, 2.00" DIA.	1	
3#	38707	DECAL, ISO PROP 65	1	
4#	23699	ISO DECAL, READ MANUAL, 2.00" DIA.	1	
5#	23700	ISO DECAL, LIFTING/CRUSH, 2.4" X 2.0"	1	
6#	30538	DECAL, FLAG DESIGNED AND ASSEMBLED IN USA	1	
7#	32210	DECAL, BLADES PANS OPTIONS	1	
8#	36099	ISO DECAL, PROTECTIVE CLOTHING, 3.50" X 1.13"	1	
9#	23701	ISO DECAL, ASK FOR TRAINING, 2.00" DIA.	1	
10	23803-108	ISO DECAL, GUARANTEED SOUND 108 DB(A)	1	
11	13811	DECAL, SERIAL PLATE	1	
12	4014	SCREW, 2-3/16 P-K TYPE U-DRIVE	2	
13#	22070	DECAL, MQ WHITEMAN POWER TROWEL 3.78" DIA.	1	
14	24454	DECAL, NO EXPOSED BLADE	3	
15#	23704	ISO DECAL, GUARD WARNING 2.00" DIA.	1	
16#	23698	ISO DECAL, ROTATING BLADE HAZARD, 2.00" DIA.	1	
17	32344	DECAL KIT, WBT HANDLES.....	1.....	INCLUDESITEMSW/%
18%	1492	DECAL, CUSTOM, 2-1/2" CHROME, WHITEMAN	1	
19%	20527	DECAL, WARNING, QUICK-PITCH WARNING .....	1.....	QUICK PITCH ONLY
20%	12405	DECAL, QUICK-PITCH HANDLE INSERT .....	2.....	QUICK PITCH ONLY
21%	20526	DECAL, WARNING, QUICK-PITCH LATCH WARNING .....	1.....	QUICK PITCH ONLY
22%	1735	DECAL, PRE-LOAD .....	1.....	QUICK PITCH ONLY
23%	2942	DECAL, MQ WHITEMAN 13" WHITE	1	
24%	23804	DECAL, ISO, DO NOT DISASSEMBLE, CYLINDER .....	1.....	QUICK PITCH ONLY

# STANDARD HANDLE ASSY.

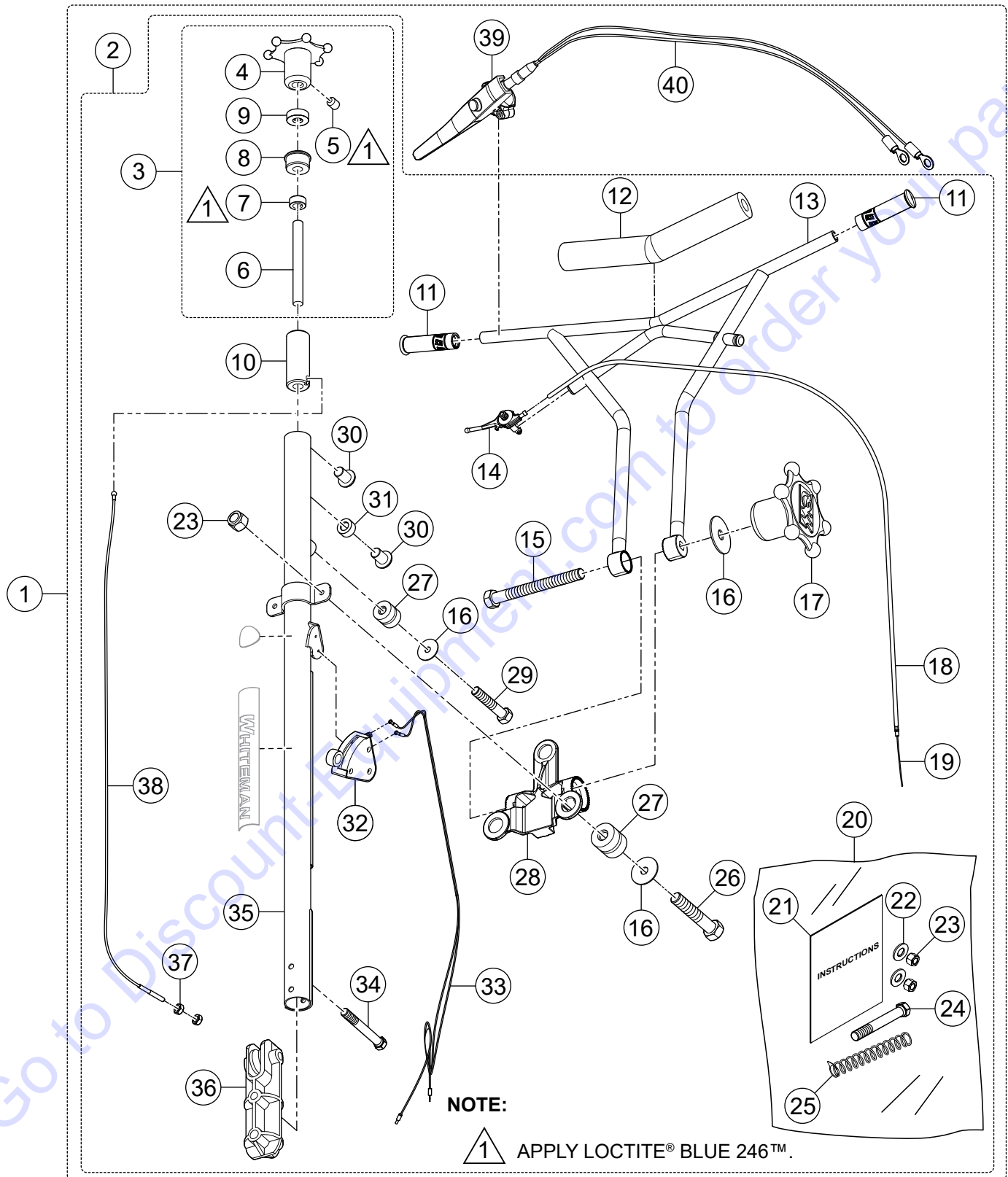



## STANDARD HANDLE ASSY.

<b>NO.</b>	<b>PART NO.</b>	<b>PART NAME</b>	<b>QTY.</b>	<b>REMARKS</b>
1	SXHP	HANDLE ASSY., STD. VIBE CONTROL OP PRESENCE .....	1.....	INCLUDES ITEMS W/%
2%	SXH	HANDLE ASSY., STD. VIBE CONTROL .....	1.....	INCLUDES ITEMS W/@
3% @	20819	HAND WHEEL ASSY., PITCH CONTROL .....	1.....	INCLUDES ITEMS W/#
4% @ #	20817	WHEEL, HAND J-B HANDLES	1	
5% @ #	0122 C	SCREW, SHS 3/8-16 X 1/2"	1	
6% @ #	1478	SHAFT, TROWEL CONTROL	1	
7% @ #	3615	COLLAR, SET 3/4" ID	1	
8% @ #	20282	BEARING, TROWEL CONTROL	1	
9% @ #	0281	BEARING, THRUST, NICE 607	1	
10% @	20287	SLIDE BLOCK, TROWEL CONTROL	1	
11% @	22762	GRIP, HANDLE, 0.875"	2	
12% @	22166	COVER, VIBE CONTROL HANDLE PAD	1	
13% @	22055	HANDLE W/A, VIBRATION CONTROL, PAINTED	1	
14% @	21171	THROTTLE, BICYCLE FINISHER HANDLES	1	
15% @	22167	SCREW, HHC 3/8-16 X 6.5" GRADE 5	1	
16% @	3233	WASHER, FENDER 3/8 X 1-1/2"	4	
17% @	20439	WHEEL ASSY., HAND	1	
18% @	21173	HOUSING, MAGURA THROTTLE CABLES	1	
19% @	21172	CABLE, THROTTLE 68"	1	
20% @	22100	KIT, VIBE CONTROL HANDLE INSTALLATION	1	
21% @	20485	INSTRUCTION, TH WBT CAB HKUP	1	
22% @	10136	WASHER, FLAT SAE 3/8"	2	
23% @	10133	NUT, NYLOC 3/8-16	4	
24% @	1493	SCREW, HHC 3/8-16 X 3.25"	1	
25% @	21746	SPRING, PRIMARY THROTTLE RETURN	1	
26% @	1665	SCREW, HHC 3/8-16 X 2"	2	
27% @	22059	ISOLATOR, VIBRATION	3	
28% @	22206	CHASSIS, CAST VIBRATION ISOLATOR	1	
29% @	9154	SCREW, HHC 3/8-16 X 1-3/4"	1	
30% @	0786	SCREW, BHC 1/4-20 X 3/8" NYL PATCH, NP	2	
31% @	0786 A	SPACER, SLIDE BLOCK GUIDE, .360 X 17/64 X 1/8L	1	
32% @	20856	SWITCH ASSY., KILL	1	
33% @	21953	SWITCH HARNESS, CENTRIFUGAL	1	
34% @	21017	SCREW, HHC 3/8-16 X 3.25" FULL THRD GR5	1	
35% @	22095	HANDLE, STOW FIN VIBE CONTROL	1	
36% @	20280	BLOCK, PITCH CONTROL	1	
37% @	1116	NUT, BRASS JAM 5/16-18	2	
38% @	20285	CABLE, CONTROL	1	
39%	21912	OPERATOR PRESENCE HANDLE, MAGURA 90.633	1	
40%	21957	HARNESS, PRESENCE SWITCH, 32.5" LONG	1	

# QUICK-PITCH™ HANDLE ASSY.

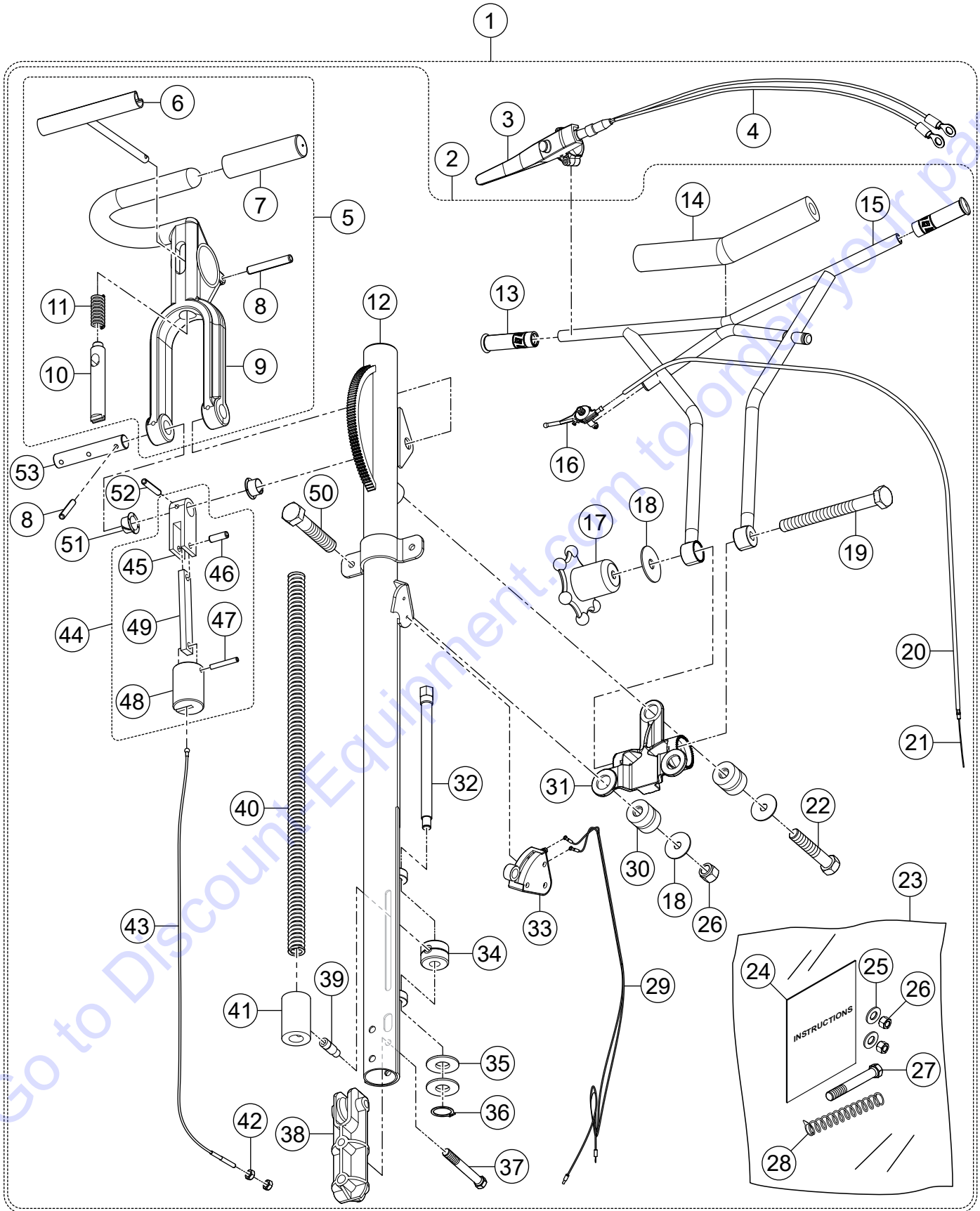

## QUICK-PITCH™ HANDLE ASSY.

NO.	PART NO.	PART NAME	QTY.	REMARKS
1	QXHP	HANDLE ASSY., QP VIBE CONTROL OP PRESENCE.....	1.....	INCLUDES ITEMS W/@
2@	QXH	HANDLE ASSY., HD QUICK PITCH VIBE CONTROL .....	1.....	INCLUDES ITEMS W/#
3@	21912	OPERATOR PRESENCE HANDLE KIT	1	
4@	21957	HARNESS, PRESENCE SWITCH, 32.5" LONG	1	
5@#	20390	TRIGGER, QP ASSEMBLY.....	1.....	INCLUDES ITEMS W/\$
6@#\$	1746	TRIGGER, QP	1	
7@#\$	1724	GRIP, HANDLE	1	
8@#\$	1729	PIN, SLOTTED SPRING, 3/16 X 1-1/4"	3	
9@#\$	20389	HANDLE, QP	1	
10@#\$	20437	PIN, QP LATCH	1	
11@#\$	1706	SPRING, COMPRESSION	1	
12@#	22060	MAIN HANDLE, QUICK PITCH VIBE CONTROL	1	
13@#	22762	GRIP, HANDLE, 0.875 W/ .63 HOLE	2	
14@#	22166	COVER, VIBE CONTROL HANDLE PAD	1	
15@#	22055	HANDLE, VIBRATION CONTROL	1	
16@#	22732	THROTTLE LEVER ASSY.	1	
17@#	20439	WHEEL ASSY., HAND	1	
18@#	3233	WASHER, FENDER, 1.5" OD X 3/8" ID	4	
19@#	22167	SCREW, HHC 3/8-16 X 6.5" GRADE 5	1	
20@#	21173	HOUSING, MAGURA THROTTLE CABLES	1	
21@#	21172	CABLE, THROTTLE 68"	1	
22@#	9154	SCREW, HHC 3/8-16 X 1-3/4"	1	
23@#	22100	KIT, VIBE CONTROL HANDLE INSTALLATION .....	1.....	INCLUDES ITEMS W/%
24@#%	20485	INSTRUCTION, THROT CAB HKUP	1	
25@#%	10136	WASHER, FLAT SAE 3/8"	2	
26@#%	10133	NUT, NYLOC 3/8-16	4	
27@#%	1493	SCREW, HHC 3/8-16 X 3.25"	1	
28@#%	21746	SPRING, PRIMARY THROTTLE RETURN	1	
29@#	21953	HARNESS, PRESENCE SWITCH, 43.25" LONG	1	
30@#	22059	ISOLATOR, VIBRATION	3	
31@#	22206	CHASSIS, CAST VIBRATION ISOLATOR	1	
32@#	1717	SCREW, QP TRIM ADJUSTMENT	1	
33@#	0856	SWITCH ASSY., KILL	1	
34@#	1718	NUT, QP TRIM CNTL ADJUSTMENT	1	
35@#	1733	WASHER, 1/2" X 1/32"	2	
36@#	1737	SNAP RING, EXTERNAL, 0.5" DIA.	1	
37@#	21017	SCREW, HHC 3/8-16 X 3.25" FULL THRD GR5	1	
38@#	20280	BLOCK, PITCH CONTROL	1	
39@#	1732	PIN, ADJUSTMENT, QP	1	

# QUICK-PITCH™ HANDLE ASSY. (CONTINUED)

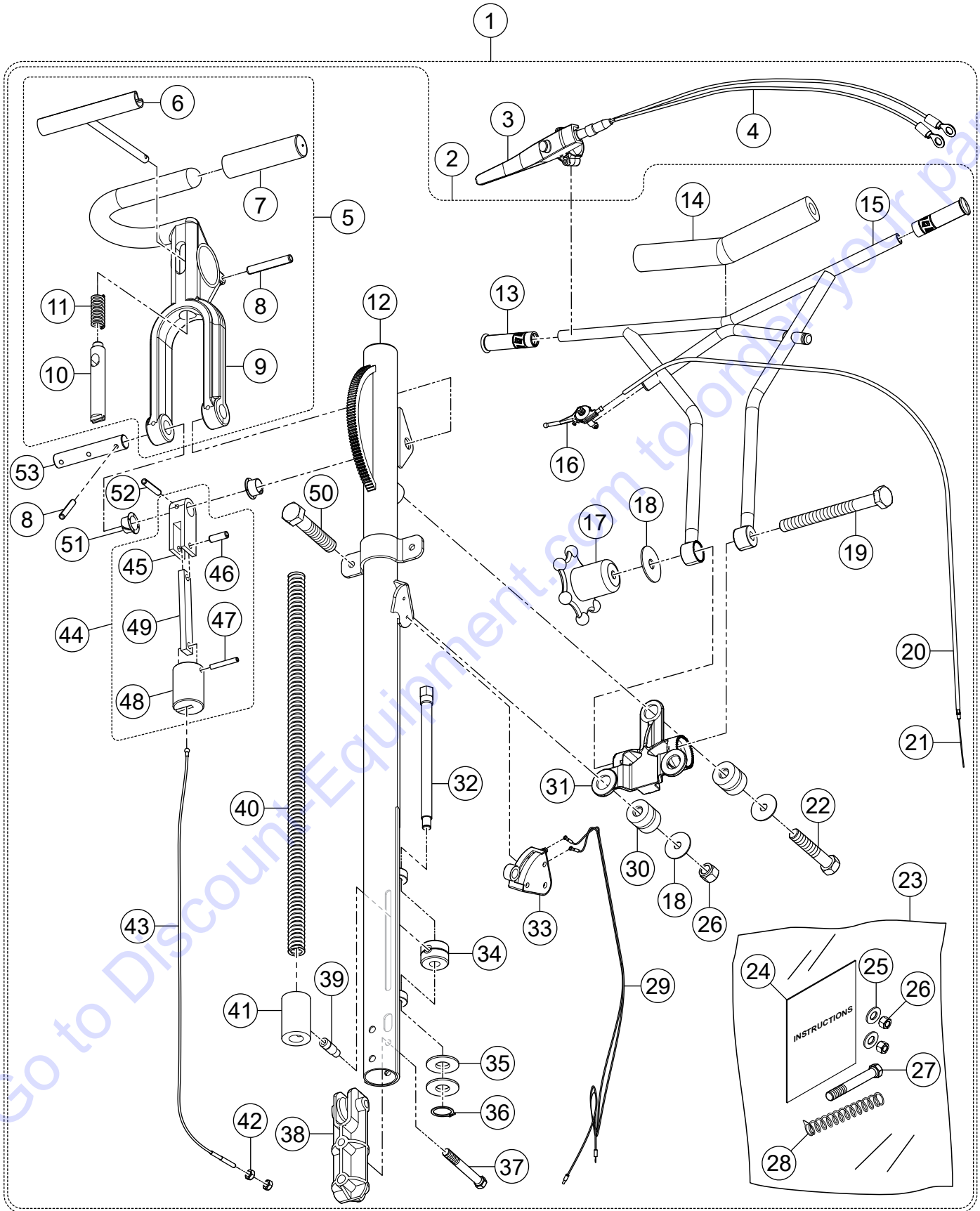

## QUICK-PITCH™ HANDLE ASSY. (CONTINUED)

40@#	1715	QP SPRING CENTER BALANCE	1	
41@#	20270	QP ADJUSTMENT BLOCK	1	
42@#	1116	NUT, BRASS JAM 5/16-18	2	
43@#	20297	CABLE, CONTROL	1	
44@#	20293	LINKAGE QP CONTROL.....	1	INCLUDES ITEMS W/&
45@#&	20443	ARM, SLIDE CONTROL	1	
46@#&	1731	PIN, ROLL 1/4" X 3/4"	1	
47@#&	20276	PIN, ROLL 1/4" X 1-3/4"	1	
48@#&	20269	BLOCK, CABLE SLIDE	1	
49@#&	1709	QP DOGBONE	1	
50@#	1665	SCREW, HHC 3/8-16 X 2"	2	
51@#	1719	BUSHING, PIVOT PLATE	2	
52@#	4568	PIN, ROLL 3/16 X 1"	1	
53@#	1711	SHAFT, CONTROL QP	1	

# GUARD RING ASSY.

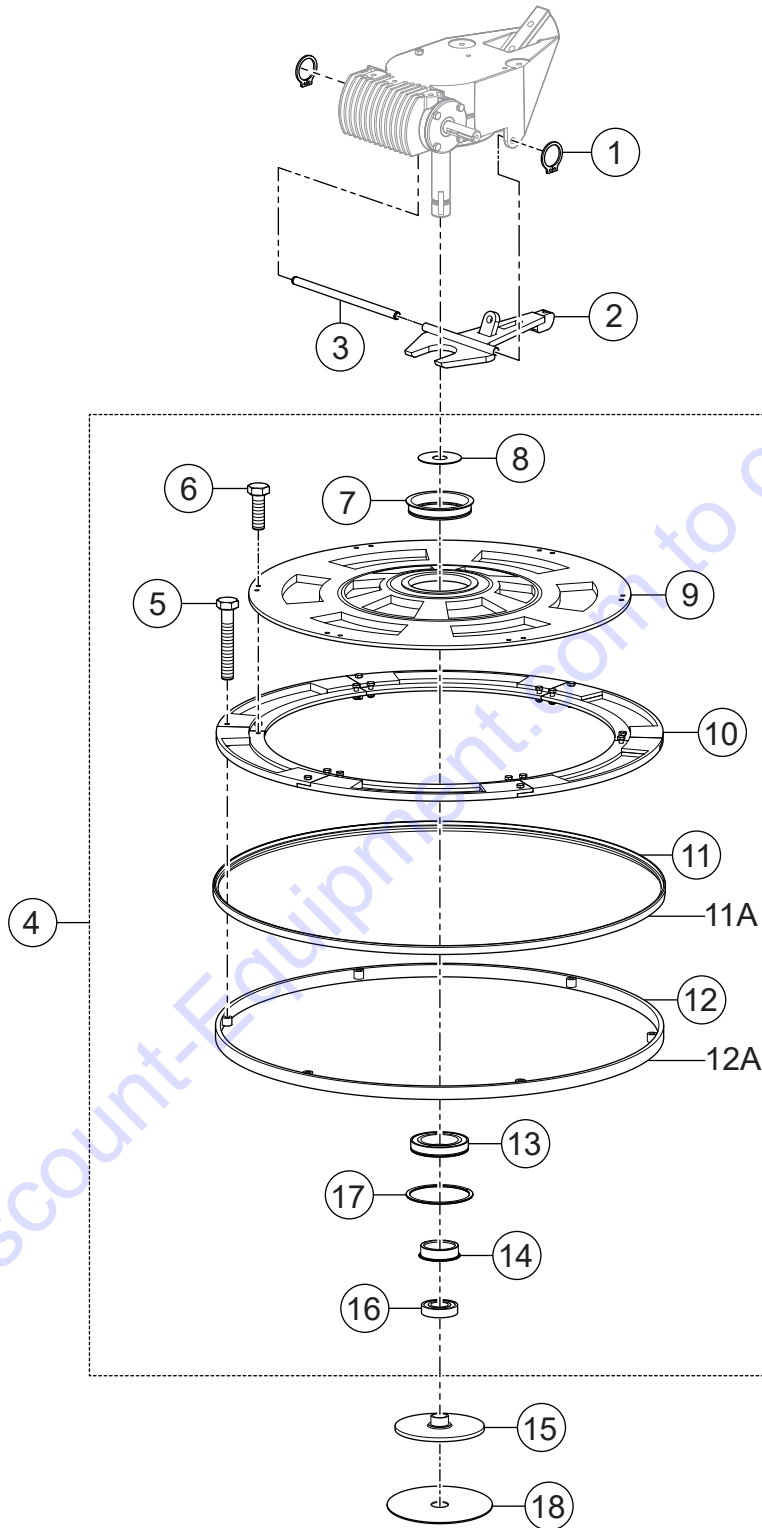

## GUARD RING ASSY.

<u>NO.</u>	<u>PART NO.</u>	<u>PART NAME</u>	<u>QTY.</u>	<u>REMARKS</u>
1	20802	RING, SNAP, TRUARC	2	
2	30624	YOKE ASSY.	1	
3	20801	PIN, YOKE	1	
4	30640	KIT, GUARD RING.....	1	INCLUDES ITEMS W/@
5@	9182	SCREW, HHC M8-1.25 X 45MM	6	
6@	1605	SCREW, HHC M8-1.25 X 25MM	12	
7@	24532	BEARING HOLDER	1	
8@	24386	WEAR PLATE, UPPER	1	
9@	24389	GUARD RING, 30"	1	
10@	24390	GUARD RING SEGMENT, 36"	6	
11@	24394	BUMPER, 36"	1	
11A@	24393	BUMPER, 30"	1	
12@	24392	RING, BUMPER, 36"	1	
12A@	24391	RING, BUMPER, 30"	1	
13@	24064	BEARING, 2.9375" I.D. 4.527" O.D. W/O RING	1	
14@	21434	SLEEVE, PITCH	1	
15	10567	THRUST PLATE	1	
16@	10607	BEARING, THRUST	1	
17@	24533	RING, BEARING RETAINER	1	
18	10639	WEAR PLATE, THRUST COLLAR	1	

# GEARBOX ASSY.

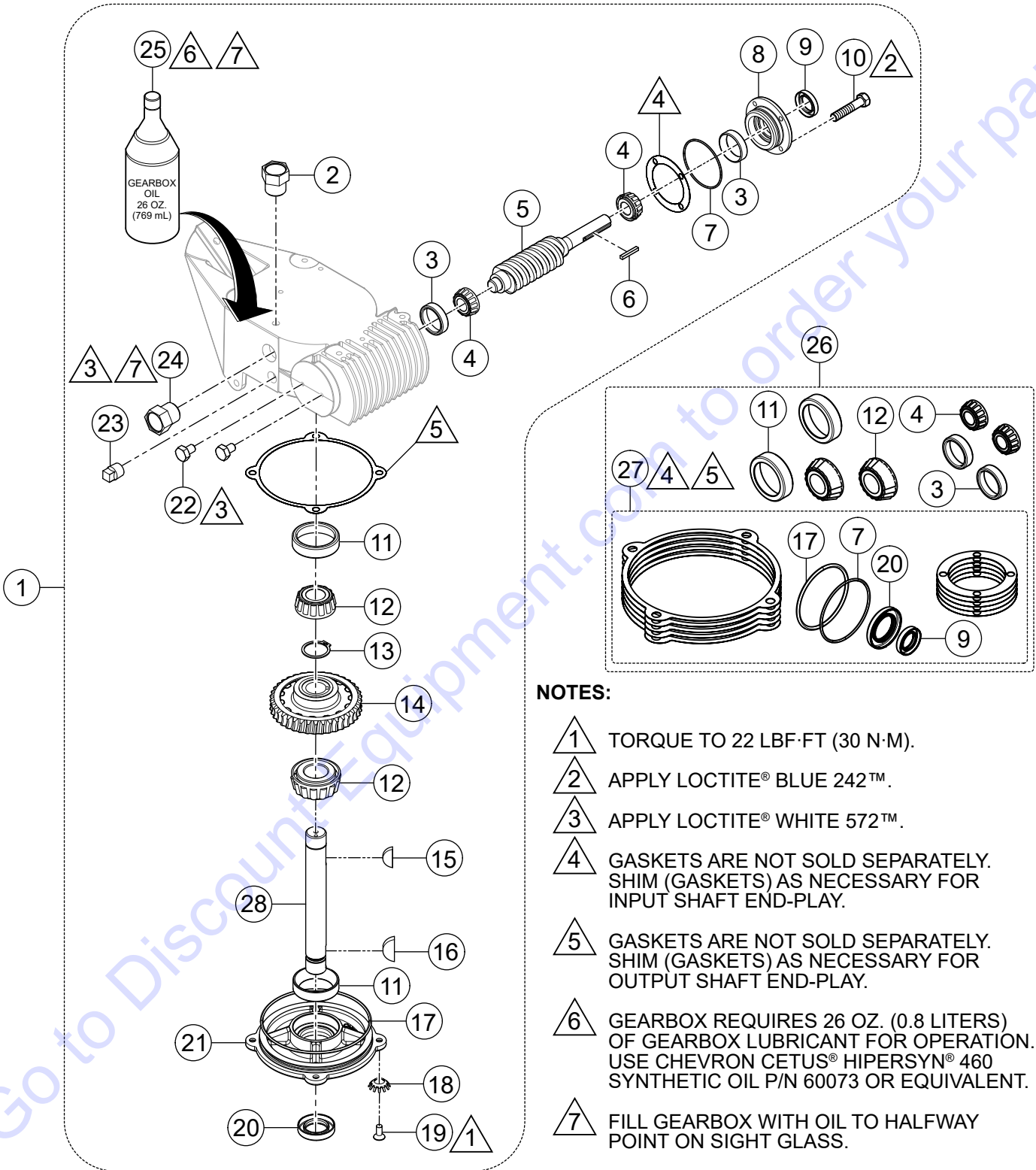

## NOTES:

- 1** TORQUE TO 22 LBF·FT (30 N·M).
- 2** APPLY LOCTITE® BLUE 242™.
- 3** APPLY LOCTITE® WHITE 572™.
- 4** GASKETS ARE NOT SOLD SEPARATELY. SHIM (GASKETS) AS NECESSARY FOR INPUT SHAFT END-PLAY.
- 5** GASKETS ARE NOT SOLD SEPARATELY. SHIM (GASKETS) AS NECESSARY FOR OUTPUT SHAFT END-PLAY.
- 6** GEARBOX REQUIRES 26 OZ. (0.8 LITERS) OF GEARBOX LUBRICANT FOR OPERATION. USE CHEVRON CETUS® HIPERSYN® 460 SYNTHETIC OIL P/N 60073 OR EQUIVALENT.
- 7** FILL GEARBOX WITH OIL TO HALFWAY POINT ON SIGHT GLASS.



## GEARBOX ASSY.

<u>NO.</u>	<u>PART NO.</u>	<u>PART NAME</u>	<u>QTY.</u>	<u>REMARKS</u>
1	30634	GEARBOX ASSY. ....	1.....	INCLUDES ITEMS W/@
2@	21218	VENT, AIR, GEARBOX	1	
3@#	20466	BEARING, CUP TIMKEN LM11910	4	
4@#	20465	BEARING, CONE TIMKEN LM11949	4	
5@	1851	WORM "B" INPUT SHAFT	1	
6@	0627	KEY, 3/16 X 1-1/4"	1	
7@#%	20395	O-RING, 139 BUNA-N	1	
8@	12876	FLANGE, INPUT SHAFT	1	
9@#%	0753	SEAL, OIL, DUAL LIP, 1.250 X .750 X .250	1	
10@	0131 A	SCREW, HHC 1/4-20 X 3/4"	4	
11@#	20475	BEARING, CUP TIMKEN M86610	4	
12@#	20474	BEARING, CONE TIMKEN M86647	4	
13@	1138	RING, SNAP	1	
14@	1140	GEAR, WORM, COMPOSITE	1	
15@	1139	KEY, WOODRUFF #810 1/4 X 1-1/4" (#21)	1	
16@	1238	KEY, WOODRUFF #1012 5/16 X 1-1/2" (#25)	1	
17@#%	20396	O-RING, SIZE-257 BUNA-N	1	
18@	10235	WASHER, LOCK 5/16" EXT. TOOTH CSINK	4	
19@	20875	SCREW, FHSC 5/16-18 X 3/4"	4	
20@#%	0254	SEAL, OIL DLIP 1.125 X 1.87 X .250	1	
21@	12875	COVER, GEARBOX	1	
22@	20476	SCREW, HHC 1/4-28 X 3/8"	2	
23@	0121 A	PIPE PLUG 3/8"	1	
24@	21033	SIGHT GLASS, 3/4" NPT, STEEL, NO BALL	1	
25@	60073	OIL, GEAR, ISO GRADE 460 26 OZ. (769 ML)	1	
26	21047	KIT, BEARING/SEAL .....	1.....	INCLUDES ITEMS W/#
27#	21046	KIT, SEAL.....	1.....	INCLUDES ITEMS W/%
28@	30635	SHAFT, OUTPUT Ø1.126 X 9.3 WD KEYS	1	

# ENGINE AND CLUTCH ASSY.

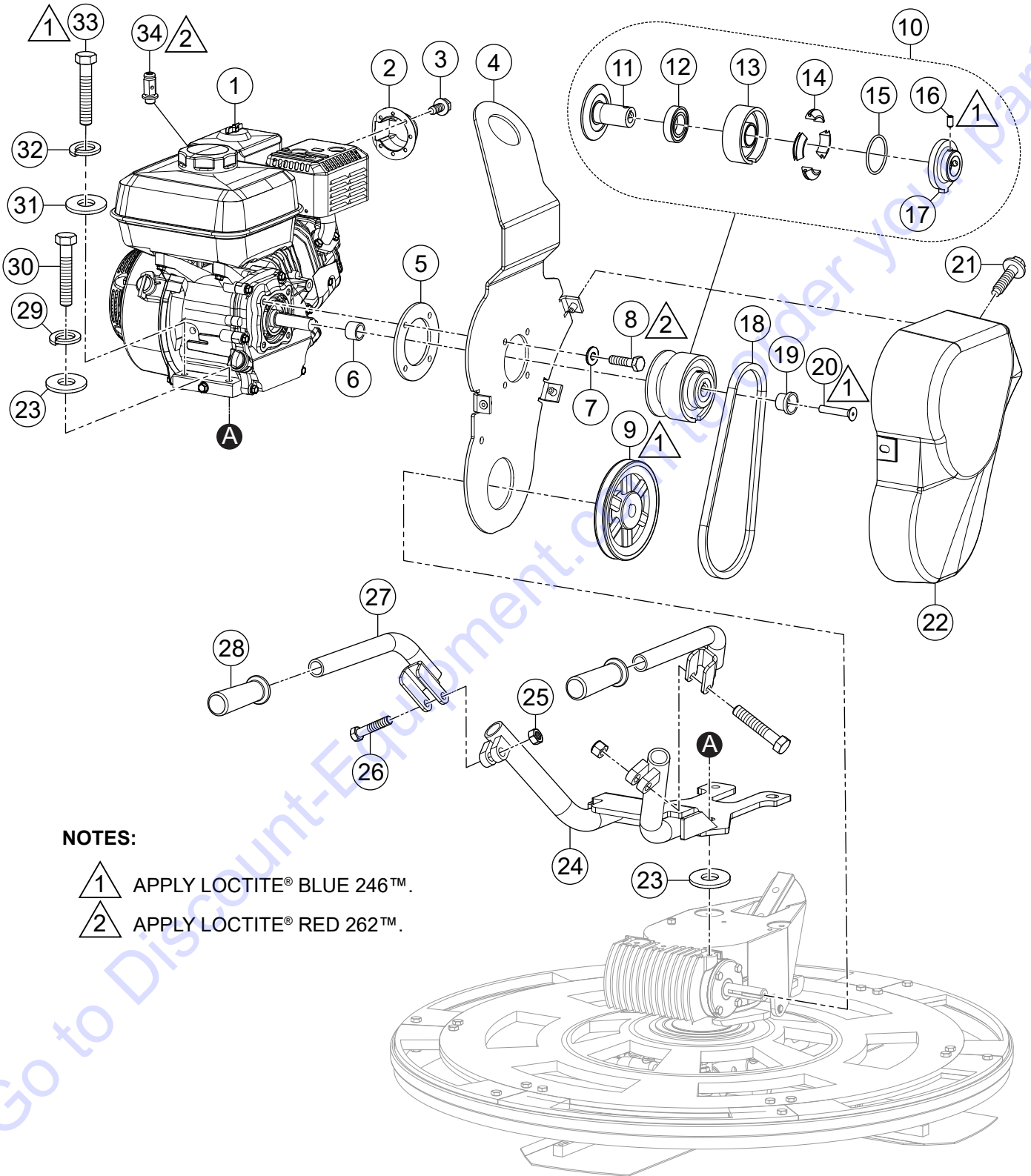

## ENGINE CLUTCH ASSY.

<u>NO.</u>	<u>PART NO.</u>	<u>PART NAME</u>	<u>QTY.</u>	<u>REMARKS</u>
1	22901	ENGINE, HONDA GX160 (4.8 HP)	1	
2	1834	DEFLECTOR, HONDA 5 HP EXHAUST	1	
3	1273	SCREW, HHF, #8-32 X 3/8", TYPE F, ZP	2	
4	30633	LIFTING BAIL	1	
5	21915	SPACER, LIFTING BAIL	1	
6	21679	SPACER 1" X .78 X 69 L	1	
7	933241	WASHER, FLAT SAE 5/16" GRD 9 YZ	4	
8	10229	SCREW, HHC 5/16-24 X 1"	4	
9	21994	PULLEY, AK59 X 3/4" BORE	1	
10	0255	CLUTCH ASSEMBLY, 3/4" CENTRIFUGAL	1	INCLUDES ITEMS W/@
11@	21307	CLUTCH SPINDLE, 3/4" BORE	1	
12@	0456	BEARING, SHIELDED 6007 ZZ E	1	
13@	0251	DRUM, CENTRIFUGAL CLUTCH	1	
14@	B1766	WEIGHT-AUTOMATIC CLUTCH	4	
15@	0855	SPRING, CLUTCH .156 X 5.375 X .025	1	
16@	1868	SCREW, SHS 3/8-24 X 3/4", NP	1	
17@	0253	CLUTCH PLATE	1	
18	30648	BELT, A26	1	
19	1406	END PLUG, CLUTCH	1	
20	21678	SCREW, FHSC 5/16-24 X 1-3/4"	1	
21	30119	SCREW, 1/4-20 X 7/8" IND HEX, DOG PT	3	
22	30344	BELT GUARD, FRICTION CLUTCH	1	
23	10136	WASHER, FLAT SAE 3/8"	2	
24	30632	HANDLE, LIFT	1	
25	10133	NUT, NYLOC 3/8-16	2	
26	1665	SCREW, HHC 3/8-16 X 2"	2	
27	30645	HANDLE, LIFT, UPPER	2	
28	15081	GRIP, 1" I.D. X 4.5	2	
29	0166 A	WASHER, LOCK, 3/8" MED.	1	
30	9154	SCREW, HHC 3/8-16 X 1-3/4"	1	
31	0300 B	WASHER, FLAT SAE 5/16"	3	
32	0161 C	WASHER, LOCK 5/16" MED.	3	
33	1207	SCREW, HHC 5/16-18 X 1-3/4"	3	
34	20845	SWIVEL, ASSY. THROTTLE CABLE	1	

# SPIDER ASSY.

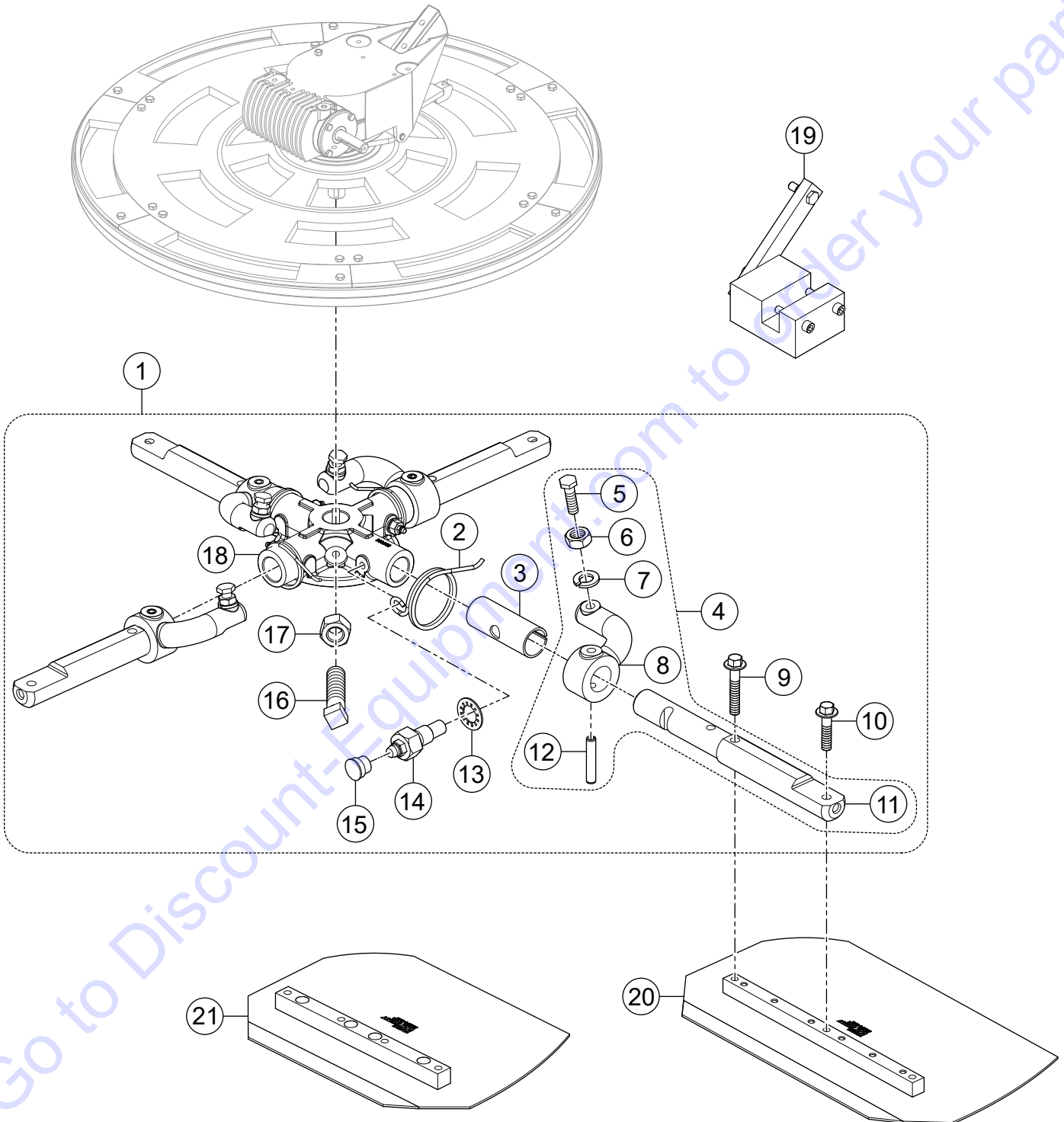

## SPIDER ASSY.

<u>NO.</u>	<u>PART NO.</u>	<u>PART NAME</u>	<u>QTY.</u>	<u>REMARKS</u>
1	30636	SPIDER W/ ARMS ASSY.....	1.....	INCLUDES ITEMS W/@
2@	1316	SPRING, LS ARM RETURN	4	
3@	1157 A	BUSHING, TROWEL ARM	4	
4@	30638	TROWEL ARM ASSY.....	4.....	INCLUDES ITEMS W/#
5@#	0164 B	SCREW, TROWEL ADJUSTMENT 3/8-16	4	
6@#	1876	NUT, HEX JAM 3/8-16 CLASS 2B	4	
7@#	0166 A	WASHER, LOCK, 3/8" MED.	4	
8@#	1163	LEVER, TROWEL ARM, RIGHT HAND	4	
9@	21906	SCREW, HHFS 5/16-18 X 1-1/2" GR 5	4	
10@	42036	SCREW, HHFS 5/16-18 X 1-1/4" GR 5	4	
11@#	30639	ARM, TROWEL, 2826 MODIFIED	4	
12@#	4164	PIN, SLOTTED SPRING, 5/16" X 1-3/4" NP	4	
13@	1875	WASHER, INT. SHKP, 3/8"	4	
14@	1322	SCREW ASSY., TROWEL ARM RETAINING	4	
15@	1162 A	CAP, GREASE ZERK, #2 YELLOW	4	
16@	12097	SCREW, SQHS 3/8-16 X 1-3/4" CONE	1	
17@	1456	NUT, HEX FINISH 3/8-16	1	
18@	30642	SPIDER PLATE, 1-1/8" SHAFT 4 BLD	1	
19	1817	TROWEL ARM ADJUSTMENT TOOL	1	
20	30699	BLADES, TROWEL COMBO 8" X 14"	4	
21	30698	COMBO EDGER BLADE, 30" WBT 8" X 10.5"	4	

# ENGINE SERVICE PARTS

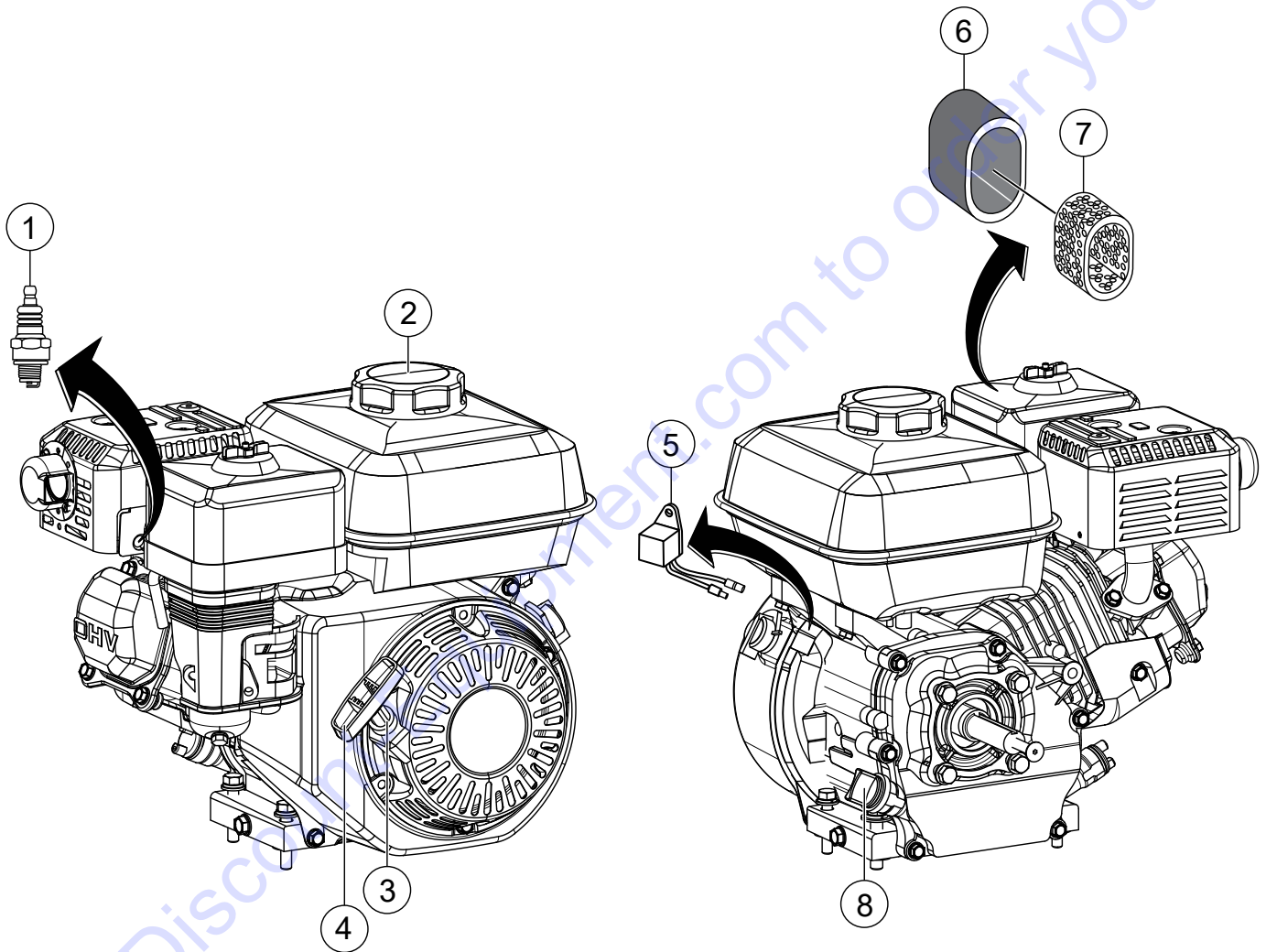

## ENGINE SERVICE PARTS

<u>NO.</u>	<u>PART NO.</u>	<u>PART NAME</u>	<u>QTY.</u>	<u>REMARKS</u>
1	9807956846	SPARK PLUG, BPR6ES	1	
2	17620Z4H900	CAP, FUEL TANK, CHROME PLATED	1	
3	28462ZH8003	ROPE, RECOIL STARTER	1	
4	28461Z4M305	KNOB, RECOIL STARTER	1	
5	34150ZH7023	ALERT UNIT, OIL	1	
6	17218ZE1507	FILTER, OUTER FOAM	1	
7	17210ZE1517	ELEMENT, AIR CLEANER	1	
8	15600Z0T810	CAP ASSY., OIL FILLER	1	

Go to Discount-Equipment.com to order your parts

# PARTS FINDER

**Search Website  
by Part Number**



**Search Manual  
Library For Parts  
Manual & Lookup Part  
Numbers – Purchase  
or Request Quote**

**Can't Find Part or  
Manual? Request Help  
by Manufacturer,  
Model & Description**

Discount-Equipment.com is your online resource for quality parts & equipment.

Florida: **561-964-4949** Outside Florida TOLL FREE: **877-690-3101**

**Need parts?**

Click on this link: <http://www.discount-equipment.com/category/5443-parts/> and choose one of the options to help get the right parts and equipment you are looking for. Please have the machine model and serial number available in order to help us get you the correct parts. If you don't find the part on the website or on one of the online manuals, please fill out the request form and one of our experienced staff members will get back to you with a quote for the right part that your machine needs.

We sell worldwide for the brands: Genie, Terex, JLG, MultiQuip, Mikasa, Essick, Whiteman, Mayco, Toro Stone, Diamond Products, Generac Magnum, Airman, Haulotte, Barreto, Power Blanket, Nifty Lift, Atlas Copco, Chicago Pneumatic, Allmand, Miller Curber, Skyjack, Lull, Skytrak, Tsurumi, Husquvarna Target, Stow, Wacker, Sakai, Mi-T-M, Sullair, Basic, Dynapac, MBW, Weber, Bartell, Bennar Newman, Haulotte, Ditch Runner, Menegotti, Morrison, Contec, Buddy, Crown, Edco, Wyco, Bomag, Laymor, EZ Trench, Bil-Jax, F.S. Curtis, Gehl Pavers, Heli, Honda, ICS/PowerGrit, IHI, Partner, Imer, Clipper, MMD, Koshin, Rice, CH&E, General Equipment, Amida, Coleman, NAC, Gradall, Square Shooter, Kent, Stanley, Tamco, Toku, Hatz, Kohler, Robin, Wisconsin, Northrock, Oztec, Toker TK, Rol-Air, APT, Wylie, Ingersoll Rand / Doosan, Innovatech, Con X, Ammann, Mecalac, Makinex, Smith Surface Prep, Small Line, Wanco, Yanmar