

# OPERATION MANUAL



 **WHITEMAN** SERIES

**MODEL**

**WTB-16PD**

**TRACK-DRIVE POWER BUGGY**

**(HONDA GX690RHKXA ELECTRIC START GASOLINE ENGINE)**

Revision #2 (10/13/22)



THIS MANUAL MUST ACCOMPANY THE EQUIPMENT AT ALL TIMES.

**TO PURCHASE THIS PRODUCT PLEASE CONTACT US**



**Equipment Financing and  
Extended Warranties Available**



**Discount-Equipment.com is your online resource for  
commercial and industrial quality parts and equipment sales.**

**561-964-4949**

**visit us on line @ [www.discount-equipment.com](http://www.discount-equipment.com)**

Select an option below to find your Equipment

**Search by Manufacturer**

**Search by Product Type**

**Request a Quote**

We sell worldwide for the brands: Genie, Terex, JLG, MultiQuip, Mikasa, Essick, Whiteman, Mayco, Toro Stone, Diamond Products, Generac Magnum, Airman, Haulotte, Barreto, Power Blanket, Nifty Lift, Atlas Copco, Chicago Pneumatic, Allmand, Miller Curber, Skyjack, Lull, Skytrak, Tsurumi, Husquvarna Target, Stow, Wacker, Sakai, Mi-T-M, Sullair, Basic, Dynapac, MBW, Weber, Bartell, Bennar Newman, Haulotte, Ditch Runner, Menegotti, Morrison, Contec, Buddy, Crown, Edco, Wyco, Bomag, Laymor, EZ Trench, Bil-Jax, F.S. Curtis, Gehl Pavers, Heli, Honda, ICS/PowerGrit, IHI, Partner, Imer, Clipper, MMD, Koshin, Rice, CH&E, General Equipment, Amida, Coleman, NAC, Gradall, Square Shooter, Kent, Stanley, Tamco, Toku, Hatz, Kohler, Robin, Wisconsin, Northrock, Oztec, Toker TK, Rol-Air, APT, Wylie, Ingersoll Rand / Doosan, Innovatech, Con X, Ammann, Mecalac, Makinex, Smith Surface Prep, Small Line, Wanco, Yanmar

**PROPOSITION 65 WARNING**

---



To order go to Discount-Equipment.com

**WTB-16PD Power Buggy**

Proposition 65 Warning ..... 2  
Safety Information ..... 4–11  
Specifications (Track Buggy) ..... 12  
Noise and Vibration/Engine Specifications ..... 13  
Dimensions ..... 14  
General Information ..... 15  
Lifting and Transporting ..... 16  
Components (Buggy) ..... 18–21  
Basic Engine Components ..... 22  
Inspection ..... 23–25  
Operation ..... 26–31  
Maintenance ..... 32–41  
Long-Term Storage/Troubleshooting (Track Buggy) ..... 42  
Troubleshooting (Engine) ..... 43–44  
Hydraulic System Diagram ..... 45  
Hydraulic Hose Connections 1 ..... 46  
Hydraulic Hose Connections 2 ..... 47  
Hydraulic Hose Connections 3 ..... 48  
Electrical Component Locator Diagram ..... 49  
Electrical Wiring Diagram ..... 50–51

To order go to [Discount-Equipment.com](http://Discount-Equipment.com)

# SAFETY INFORMATION

Do not operate or service the equipment before reading the entire manual. Safety precautions should be followed at all times when operating this equipment. Failure to read and understand the safety messages and operating instructions could result in injury to yourself and others.



## SAFETY MESSAGES

The four safety messages shown below will inform you about potential hazards that could injure you or others. The safety messages specifically address the level of exposure to the operator and are preceded by one of four words: **DANGER**, **WARNING**, **CAUTION** or **NOTICE**.

## SAFETY SYMBOLS

**! DANGER**

Indicates a hazardous situation which, if not avoided, **WILL** result in **DEATH** or **SERIOUS INJURY**.

**! WARNING**

Indicates a hazardous situation which, if not avoided, **COULD** result in **DEATH** or **SERIOUS INJURY**.





**! CAUTION**

Indicates a hazardous situation which, if not avoided, **COULD** result in **MINOR** or **MODERATE INJURY**.

**NOTICE**

Addresses practices not related to personal injury.

Potential hazards associated with the operation of this equipment will be referenced with hazard symbols which may appear throughout this manual in conjunction with safety messages.

SYMBOL	SAFETY HAZARD
	<p><b>WARNING</b> Lethal Exhaust Gas Hazard</p> <ul style="list-style-type: none"> <li>• Inhaling exhaust fumes can result in severe injury or death.</li> <li>• Only operate equipment in well ventilated areas.</li> <li>• <b>DO NOT</b> inhale exhaust gases/fumes.</li> </ul>
	<p><b>WARNING</b> Explosive Fuel Hazard</p> <ul style="list-style-type: none"> <li>• Gasoline fuel can cause fire or explosion. Stop engine before refueling.</li> <li>• Keep cigarettes, sparks and flames away from hot surfaces.</li> </ul>
	<p><b>CAUTION</b> Burn Hazard</p> <ul style="list-style-type: none"> <li>• <b>HOT PARTS</b> can burn skin.</li> <li>• <b>DO NOT</b> touch hot parts. Allow machine a sufficient amount of time to cool before performing maintenance.</li> </ul>
	<p><b>WARNING</b> Rotating Parts Hazard</p> <p>Keep hands clear of rotating parts at all times.</p>
	<p><b>CAUTION</b> Burn Hazard</p> <ul style="list-style-type: none"> <li>• <b>HOT FLUID</b> can burn skin.</li> <li>• <b>DO NOT</b> allow skin to come in contact with hot fluid. Allow machine a sufficient amount of time to cool before performing maintenance.</li> </ul>

# SAFETY INFORMATION

## GENERAL SAFETY

### CAUTION

- **NEVER** operate this equipment without proper protective clothing, shatterproof glasses, respiratory protection, hearing protection, steel-toed boots and other protective devices required by the job or city and state regulations.



- Avoid wearing jewelry or loose-fitting clothes that may snag on the controls or moving parts as this can cause serious injury.

- **NEVER** operate this equipment when not feeling well due to fatigue, illness or when under medication.



- **NEVER** operate this equipment under the influence of drugs or alcohol.



- **ALWAYS** clear the work area of any debris, tools, etc. that would constitute a hazard while the equipment is in operation.

- No one other than the operator is to be in the working area when the equipment is in operation.

- **DO NOT** use the equipment for any purpose other than its intended purposes or applications.

### NOTICE

- This equipment should only be operated by trained and qualified personnel 18 years of age and older.

- Whenever necessary, replace nameplate, operation and safety decals when they become difficult to read.

- Manufacturer does not assume responsibility for any accident due to equipment modifications. Unauthorized equipment modification will void all warranties.

- **NEVER** use accessories or attachments that are not recommended by Multiquip for this equipment. Damage to the equipment and/or injury to user may result.

- **ALWAYS** know the location of the nearest fire extinguisher.



- **ALWAYS** know the location of the nearest first aid kit.



- **ALWAYS** know the location of the nearest phone or **keep a phone on the job site**. Also, know the phone numbers of the nearest **ambulance, doctor and fire department**. This information will be invaluable in the case of an emergency.



# SAFETY INFORMATION

## POWER BUGGY SAFETY

### DANGER

- Engine fuel exhaust gases contain poisonous carbon monoxide. This gas is colorless and odorless, and can cause death if inhaled.
- The engine of this equipment requires an adequate free flow of cooling air. **NEVER** operate this equipment in any enclosed or narrow area where free flow of the air is restricted. If the air flow is restricted it will cause injury to people and property and serious damage to the equipment or engine.

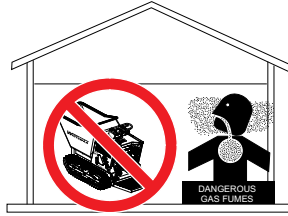

- **NEVER** operate the equipment in an explosive atmosphere or near combustible materials. An explosion or fire could result causing severe **bodily harm or even death.**



### WARNING

- **NEVER** use your hand to find hydraulic leaks. Use a piece of wood or cardboard. Hydraulic fluid injected into the skin must be treated by a knowledgeable physician immediately or severe injury or death can occur.
- Accidental starting can cause severe injury or death. **ALWAYS** place the ON/OFF switch in the OFF position.
- **NEVER** disconnect any **emergency or safety devices.** These devices are intended for operator safety. Disconnection of these devices can cause severe injury, bodily harm or even death. Disconnection of any of these devices will void all warranties.
- **NEVER** approach power lines with any part of the buggy unless all local, state/provincial and federal (OSHA) required safety precautions have been taken. Use extreme caution when approaching high-voltage power lines.



### CAUTION

- **ALWAYS** inspect the surface over which you will travel. Look for holes, drop-offs and obstacles. Look for rough and weak spots on docks, ramps or floor. Look for oil spills, wet spots and slippery surfaces. Look for soft soil, deep mud and standing water. Watch for anything that might make you lose control or cause the power buggy to tip over.
- **ALWAYS** clear away trash and debris. Pick up anything that might puncture the rubber tracks.
- **ALWAYS** make sure aisles, ramps, doorways and passages are clear.
- **ALWAYS** plan your work. Make sure you know where you will make your pickups, dumps and turns. Before you take a load, know where you will place it.
- **NEVER** operate the power buggy facing backwards. In a backwards position, the operator cannot properly activate the manual brake, emergency switch, grip the handles or steer the machine. **ALWAYS** face in the direction of the bucket.
- **DO NOT** operate the power buggy on unsafe haul roads, load areas, or dump areas.
- **DO NOT** operate power buggy on excessive slopes with a grade higher than 20% (12°), forward and backward.
- **DO NOT** unload material from the tub where the longitudinal and lateral slope are present at the same time.
- **DO NOT** traverse with the tub lifted.
- **DO NOT** operate power buggy on extremely uneven surfaces.
- **NEVER** allow riders other than the operator on the power buggy.
- **ALWAYS** secure the step plate (platform) in the upright position when using the power buggy over rough terrain.
- **DO NOT** stand on the power buggy step plate (platform) when walking in rough terrain. Walk behind the power buggy.

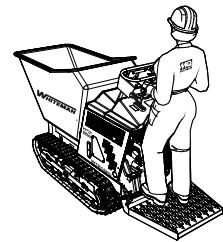

## SAFETY INFORMATION

- **DO NOT** touch, lean on or reach through the dump mechanism or permit others to do so. **NEVER** climb on the power buggy or dump mechanism.
  - **DO NOT** operate the power buggy at excessive speeds. Reckless operation may cause accidents and severe injury. Slow down when approaching people, wet areas, and going up and down grades. It is the responsibility of the operator to adjust speed, as necessary, depending on the conditions of the road or path.
  - **ALLOW** extra time to stop when operating the power buggy on wet surfaces or loosely graded materials.
  - **DO NOT** dump materials that are large and chunky. These types of materials may shift causing the power buggy to tip and throw the operator off the machine. The power buggy is intended for dumping free-flowing and loose materials such as dry soil, slag, and wet concrete.
  - **DO NOT** dump materials from bucket while the power buggy is moving.
  - For walk-behind operation, the operator platform must be stowed and locked in the up position. The speed should also be reduced to 3 mph (4.8 kph) or slower.
- NOTICE**
- **ALWAYS** ensure power buggy is **securely** placed on appropriate blocks or jack stands when performing maintenance requires elevation of the buggy.
  - **ALWAYS** make sure the power buggy's parking brake is working properly. **NEVER** operate the power buggy with a defective braking system.
  - Ensure brakes are applied when leaving or when using on a slope.
  - When parking on a slope, position the power buggy at a right angle to a slope. Ensure that the parking brake is engaged and holds the power buggy safely in place when parking on a slope.
  - When filling or dumping **DO NOT** exceed payload capacity of power buggy.
  - **ALWAYS** be aware of traveling conditions. Reduce load if necessary.
- **DO NOT** activate dump mechanism (tub) if buggy is facing a downhill slope.
  - **DO NOT** stand in front of or alongside the buggy when discharging a load.
  - **ALWAYS** block the power buggy with appropriate blocks when leaving the power buggy parked on a slope.
  - To prevent unexpected loss of control, **DO NOT** start engine on a sloping surface.
  - Ensure that both travel control levers work freely and return to their neutral position. **DO NOT** start engine unless the travel control linkage is working properly.
  - **NEVER** operate the power buggy with bad or worn rubber tracks. **ALWAYS** replace defective tracks with new ones.
  - **ALWAYS** make sure the hydraulic dumping mechanism of the tub is working properly.
  - Avoid sudden stops, starts and changes in direction. Operate the controls smoothly. **DO NOT** jerk the steering or any other controls.
  - **NEVER** attempt to work the control except from the operator's position.
  - **NEVER** drive or tow the power buggy in traffic or on public roads.
  - **ALWAYS** keep the machine in proper running condition.
  - Fix damage to machine and replace any broken parts immediately.
  - The entire power buggy (tub, step plate, shroud, rubber track, etc.) should be cleaned after every use. Make sure there is no buildup of concrete, grease, oil or debris on the machine.
  - **ALWAYS** store equipment properly when it is not being used. Equipment should be stored in a clean, dry location out of the reach of children and unauthorized personnel.
  - **ALWAYS** place the fuel valve lever in the **OFF** position when the equipment is not in use.



# SAFETY INFORMATION

## RUBBER TRACK SAFETY

- **ALWAYS** inspect the **rubber track** before each use. Be sure to check the tension and maintain the prescribed (regulated) tension.
- **ALWAYS** drive slowly in areas where the road surface is unstable such as forests, some construction sites, and/or unpaved roads. High speed in these areas can result in breakage of the rubber track.
- Remove any foreign objects such as tree branches, leaves, etc. caught between the frame and the rubber track, after each operation.
- If foreign objects are not removed between the frame and the rubber track, the gap between the rubber track and the frame will shorten, and this can make the rubber track more susceptible to cracks and wear.
- Regularly inspect the condition of the sprocket, track roller, idler, and the imbedded metal guide for abrasion. Excessive or unusual abrasion or scarring can shorten the life span of the rubber track.
- Enlarge the turning radius when turning and changing directions, in areas of high friction, such as asphalt, to avoid premature breakage of the rubber track.
- In cases where the job site location is far away, transport the machine on a flatbed truck or similar towing vehicle.
- Continuous operation over long distances for an extended period of time is not recommended.
- Driving the rubber track through narrow passages on job sites can fold the edges of the rubber track. Excessive bending of the track can lead to breakage.
- When inspecting the rubber track or its components, ensure that it is done on even ground and equipment has been turned off.
- When replacing worn or defective components, such as sprocket, track roller, idler or imbedded metal guide, replace with manufacturer's recommended parts only.
- **ALWAYS** use manufacturer's recommended parts. Unspecified parts will shorten the life span of the rubber track.
- Use the rubber track for the prescribed purposes only.

- **DO NOT** burn used or damaged rubber tracks, as noxious fumes are emitted and can cause harm if inhaled.
- In the case of long-term storage, avoid direct sunlight and keep indoors or under a protective cover.
- If the unit will not be used for a long period of time, be sure to rotate the rubber track at least once a month to avoid stress being placed on one point continuously.
- When transporting the rubber track with a forklift, be aware that the prongs can damage the track.
- When replacing the rubber track, be sure the machine is placed on secure level surface. The possibility exists of the machine rolling over if placed on an uneven surface.
- **ALWAYS** shut down the equipment (**OFF**) before removing or installing the rubber track.
- **DO NOT** apply excessive force (prybar) when removing the rubber track.



## TUB SAFETY

- Before tipping or rotating tub, make sure material is fluid and can slide freely. Discharging solid materials can be dangerous creating unstable operation. The terrain must be soild and compact.
- While rotating tub avoid abrupt movements. Rotate slow and gradual to prevent "swinging" motion which will create an unstable load condition causing the machine to tip over.
- **NEVER** jerk the pivot lever, always use a steady motion.
- **NEVER** rotate or tilt tub on a lateral or longitudinal slope which can create unstable operating conditions causing machine to tip over.
- Keep workers away from rotating tub.

# SAFETY INFORMATION

## ENGINE SAFETY

### ⚠ WARNING

- **DO NOT** place hands or fingers inside engine compartment when engine is running. 
- **NEVER** operate the engine with heat shields or guards removed.
- Keep fingers, hands, hair and clothing away from all moving parts to prevent injury. 
- **ALWAYS** shut down the engine before performing service or maintenance.
- **DO NOT** remove the engine oil drain plug while the engine is hot. Hot oil will gush out of the oil tank and severely scald any persons in the general area of the power buggy.

### ⚠ CAUTION

- **NEVER** touch the hot exhaust manifold, muffler or cylinder. Allow these parts to cool before servicing equipment. 
- Make certain the operator knows how to and is capable of turning the engine OFF in case of an emergency.

### NOTICE

- **NEVER** run engine without an air filter or with a dirty air filter. Severe engine damage may occur. Service air filter frequently to prevent engine malfunction.
- **NEVER** tamper with the factory settings of the engine or engine governor. Damage to the engine or equipment can result if operating in speed ranges above the maximum allowable. 

## FUEL SAFETY

### ⚠ DANGER

- **DO NOT** start the engine near spilled fuel or combustible fluids. Fuel is extremely flammable and its vapors can cause an explosion if ignited.
- **ALWAYS** refuel in a well-ventilated area, away from sparks and open flames.
- **ALWAYS** use extreme caution when working with **flammable** liquids.
- **DO NOT** fill the fuel tank while the engine is running or hot.
- **DO NOT** overfill tank and tighten fuel cap until you hear clicking, since spilled fuel could ignite if it comes into contact with hot engine parts or sparks from the ignition system.
- Store fuel in appropriate containers, in well-ventilated areas and away from sparks and flames.
- **NEVER** use fuel as a cleaning agent.
- **DO NOT** smoke around or near the equipment. Fire or explosion could result from fuel vapors or if fuel is spilled on a hot engine. 
- **DO NOT** leave the power buggy in the vicinity of ovens, furnaces or radiant heaters. Heat could raise the pressure of the fuel so that vented gas could ignite.

# SAFETY INFORMATION

## BATTERY SAFETY

### DANGER

- **DO NOT** drop the battery. There is a possibility that the battery will explode.
- **DO NOT** expose the battery to open flames, sparks, cigarettes, etc. The battery contains combustible gases and liquids. If these gases and liquids come into contact with a flame or spark, an explosion could occur.



### WARNING

- **ALWAYS** wear safety glasses when handling the battery to avoid eye irritation. The battery contains acids that can cause injury to the eyes and skin.
- Use well-insulated gloves when picking up the battery.
- **ALWAYS** keep the battery charged. If the battery is not charged, combustible gas will build up.
- **DO NOT** charge battery if frozen. Battery can explode. When frozen, warm the battery to at least 61°F (16°C).
- **ALWAYS** recharge the battery in a well-ventilated environment to avoid the risk of a dangerous concentration of combustible gases.
- If the battery liquid (dilute sulfuric acid) comes into contact with **clothing or skin**, rinse skin or clothing immediately with plenty of water.
- If the battery liquid (dilute sulfuric acid) comes into contact with **eyes**, rinse eyes immediately with plenty of water and contact the nearest doctor or hospital to seek medical attention.



### CAUTION

- **ALWAYS** disconnect the **NEGATIVE** battery terminal before performing service on the equipment.
- **ALWAYS** keep battery cables in good working condition. Repair or replace all worn cables.

## LIFTING SAFETY

### CAUTION

- **NEVER** allow any person or animal to stand underneath the equipment while lifting.

### NOTICE

- When lifting of the power buggy is required, attach a strap or chain of adequate lifting capacity to the lifting points on the frame. Tub will have to be placed in the dump position to gain access to the lifting points.
- **NEVER** tip the engine to extreme angles during lifting as it may cause oil to gravitate into the cylinder head, making the engine start difficult.
- **DO NOT** lift machine to unnecessary heights.
- **NEVER** lift the machine while the tub is loaded with material.
- **NEVER** lift the machine while the engine is running.
- **ALWAYS** use ramps capable of supporting the weight of the power buggy and the operator to load and unload the power buggy.

## TRANSPORTING SAFETY

### NOTICE

- **ALWAYS** shut down engine before transporting.
- Tighten fuel tank cap securely and close fuel cock to prevent fuel from spilling.
- When transporting of the power buggy is required, place the power buggy on a flatbed truck or equivalent and tie down securely.
- **ALWAYS** make sure all tie-downs and blocks are in place and the bucket is completely lowered in the flat (horizontal) position and securely latched.
- Place **chock blocks** underneath wheel to prevent rolling.
- When transporting the power buggy on a truck or trailer, know the overall height to avoid contacting overhead obstructions such as bridges and power lines. Check the truck and ramp capacities.
- **ALWAYS** place the fuel valve lever in the **OFF** position before transporting.

# SAFETY INFORMATION

## ENVIRONMENTAL SAFETY/DECOMMISSIONING

### NOTICE

Decommissioning is a controlled process used to safely retire a piece of equipment that is no longer serviceable. If the equipment poses an unacceptable and unrepairable safety risk due to wear or damage or is no longer cost effective to maintain (beyond life-cycle reliability) and is to be decommissioned (demolition and dismantlement), be sure to follow rules below.

- **DO NOT** pour waste or oil directly onto the ground, down a drain or into any water source.
- Contact your country's Department of Public Works or recycling agency in your area and arrange for proper disposal of any electrical components, waste or oil associated with this equipment.
- When the life cycle of this equipment is over, remove battery (if equipped) and bring to appropriate facility for lead reclamation. Use safety precautions when handling batteries that contain sulfuric acid.
- When the life cycle of this equipment is over, it is recommended that the unit frame and all other metal parts be sent to a recycling center.



Metal recycling involves the collection of metal from discarded products and its transformation into raw materials to use in manufacturing a new product.

Recyclers and manufacturers alike promote the process of recycling metal. Using a metal recycling center promotes energy cost savings.

## EMISSIONS INFORMATION

### NOTICE

This equipment conforms with applicable Environmental Protection Agency (EPA) and California Air Resources Board (CARB) emission regulations.

The gasoline engine used in this equipment has been designed to reduce harmful levels of carbon monoxide (CO), hydrocarbons (HC) and nitrogen oxides (NOx) contained in gasoline exhaust emissions.

Mandated Emission Components:

- Engine, EPA certified
- Fuel cap, EPA certified
- Fuel and vapor recovery hoses, EPA certified SAE J30R7 or SAE J30R14T2
- Charcoal canister, EPA certified

Miscellaneous Parts Associated with Emission System:

- Hose clamps and retainer brackets
- Roll over valve vapor recovery valve
- Steel fuel tank

Tampering with or altering the emission control system may increase emissions beyond the legal limit. Do not remove or alter any part of the system.

Additionally, modifying the fuel system may adversely affect evaporative emissions, resulting in fines or other penalties.

The emission control system is valid only for the United States, its territories and commonwealths to include Canada.

### Emission Control Label

The emission control label is an integral part of the emission system and is strictly controlled by regulation(s).

The label must remain with the engine for its entire life.

If a replacement emission label is needed, please contact Discount-equipment.

# SPECIFICATIONS (TRACK BUGGY)

<b>Table 1. Specifications (Track Buggy)</b>	
Model	WTB-16PD
Maximum Weight Capacity	2,500 lb. (1,451 kg)
Operating Weight	2,138 lb. (970 kg)
Bucket/Tub Capacity	16 cu. ft. water level (.59 cu. yd.)
Bucket/Tub Material	Polyethylene
Drive	Hydrostatic
Speed Loaded	Up to 4.7 mph (7.6 km/h)
Speed Transport	Up to 5.1 mph (8.2 km/h)
Fuel Tank Capacity	5.0 gallons (20 liters)
Hydraulic Oil Tank Capacity	5.3 gallons (20.4 liters)
Hydraulic Oil Type	Exxon/Mobil Nuto H68 or equivalent.
Hydraulic Filter, Return	10 micron
Brakes (Drive Track)	Dynamic hydrostatic
Parking Brake (Drive Tracks)	Hydraulic
Dump Control	Hydraulic Dump and Return
Pivot Control	Up to 180°
Discharge Height	10.0 in. (254 mm)
Ground Clearance	6.0 in. (152 mm)
Gradeability	20% (12°)
Battery (L x W x H)	12V BCI Group U1, 300 CCA @ 0°F 7.75 x 5.18 x 7.31 in. (197 x 132 x 186 mm)
Rubber Track	5.7 x 8.0 (145 x 203 x 483 mm)

# NOISE AND VIBRATION/ENGINE SPECIFICATIONS

Table 2. Noise and Vibration Emissions	
Model	WTB-16PD
Guaranteed ISO 11201:2010 Based Sound Pressure Level at Operator Station in dB(A)	TBD
Guaranteed ISO 3744:2010 Based Sound Power Level in dB(A)	TBD
Whole Body Vibration per ISO 2631-1:1997+A1:2010 in $m/s^2 \Sigma A(8)$	TBD

## NOTES:

1. Sound Pressure and Power Levels are "A" weighted measures per ISO 226:2003 (ANSI S1.4-1981). They are measured with the operating conditions of the machine which generate the most repeatable but highest values of the sound levels. Under normal circumstances, the sound level will vary depending on the condition of the material being worked upon.
2. The vibration level indicated is the vector sum of the RMS (Root Mean Square) values of amplitudes on each axis, standardized to an 8-hour exposure period, and obtained using operating conditions of the machine that generate the most repeatable but highest values in accordance with the applicable standards for the machine.
3. Per EU Directive 2002/44/EC, the daily exposure action value for whole body vibration is  $0.5 m/s^2 \Sigma A(8)$ . The daily exposure limit value is  $1.15 m/s^2 \Sigma A(8)$ .

Table 3. Engine Specifications	
Model	Honda GX690RHKXA Engine
Type	Air-cooled 4-stroke, overhead valve, 90° V-twin 2-cylinder, horizontal shaft, gasoline engine
Bore x Stroke	78 x 72 mm (3.1 x 2.8)
Piston Displacement	688 cc (41.9 cu. in)
Net Power Output	22 hp @ 3,600 rpm (16.5 kW)
Max. Torque	48.3 N·m (4.93 kgf·m 35.6 lbf·ft) @ 2,500 rpm
Cooling System	Forced air
Air Cleaner	Dual element
Engine Oil Capacity SAE 10W-30 API Service Class SE or later	1.6 qt. (1.50 liters) 1.8 qt. (1.7 liters w/ oil filter replacement)
Fuel	Unleaded gasoline Octane rating of 86 or higher Maximum 10% ethanol See engine manual for further details.
Fuel Consumption	6 liters/hr. @ 3,600 rpm
Starting System	Electric start/CDI type magneto ignition
Spark Plug Type	ZFR5F NGK
Spark Plug Gap	0.70–0.80 mm (0.028–0.031 in.)
L x W x H	405 x 410 x 438 mm (15.9 x 16.1 x 17.2 in.)
Weight (Dry)	44.4 kg (97.8 lb.)

# DIMENSIONS

Figure 1. WBT-16 Dimensions

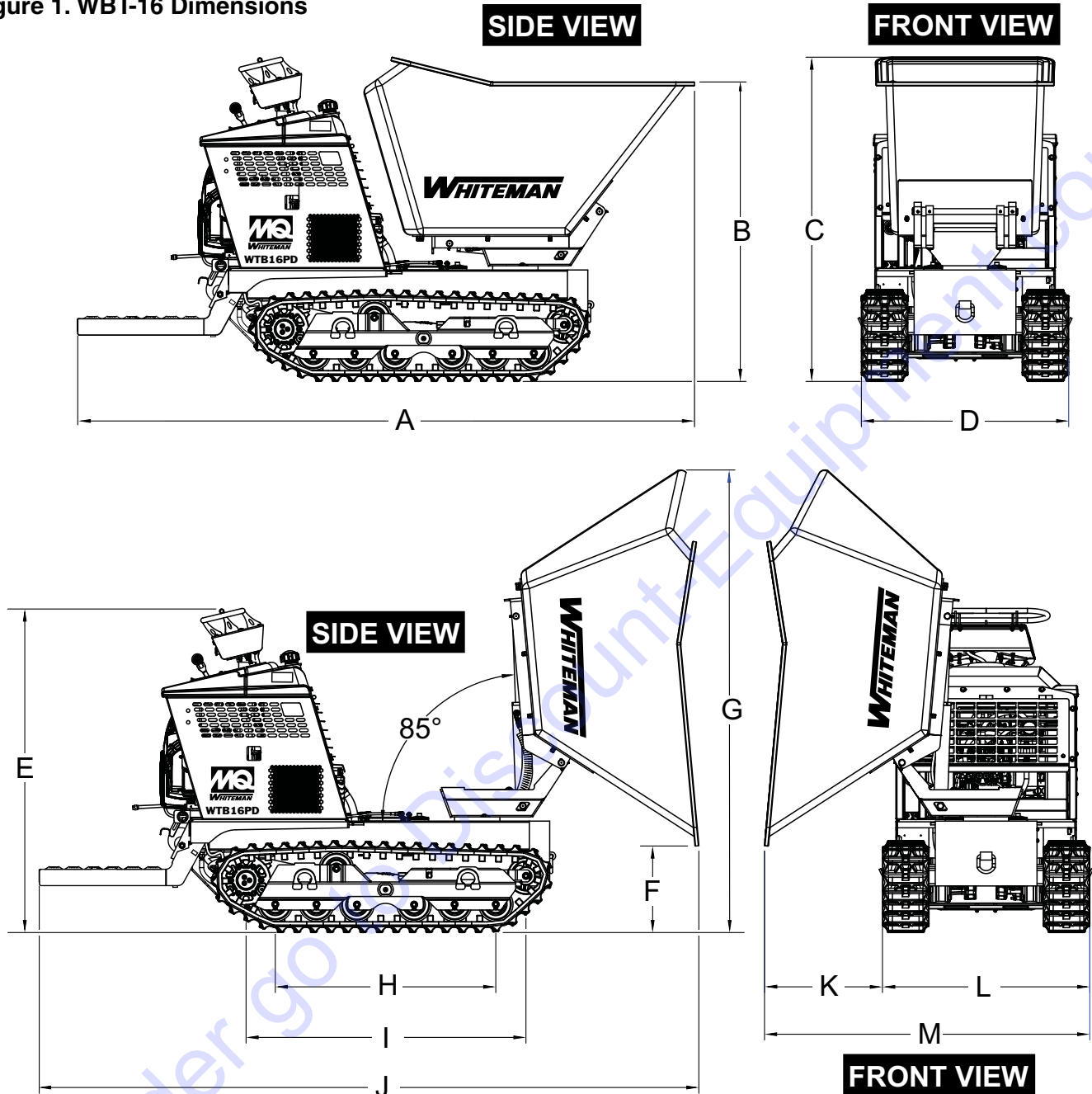

Table 4. Dimensions

Reference Letter	Dimension in. (mm)	Reference Letter	Dimension in. (mm)	Reference Letter	Dimension in. (mm)	Reference Letter	Dimension in. (mm)
A	102.30 (2,598)	E	55.60 (1,412)	I	48.10 (1,222)	M	55.90 (1,420)
B	51.50 (1,307)	F	15.00 (380)	J	110.25 (2,800)		
C	55.70 (1,415)	G	72.05 (1,830)	K	20.30 (515)		
D	35.60 (905)	H	37.90 (963)	L	35.6 (905)		

## GENERAL INFORMATION

The MQ Whiteman Track Power Buggy, WTB-16PD is intended for the transportation of concrete, concrete spreading and spot pouring. In addition, this power buggy is designed for landscaping applications, material sub-base distribution, job site cleanup and material transport.

The Power Buggy is equipped with a 10-inch dump height which provides clearance and enables the operator to maneuver over any form height. In addition, it has a unique polyethylene tub design that reduces concrete splatter.

A low center of gravity has been incorporated into the design which provides added safety when maneuvering the buggy in tight areas. A 5.0-gallon (20-liter) fuel tank allows for extended uninterrupted use. The maximum speed of the power buggy is rated at 5.1 mph (8.2 km/h).

This buggy employs 16-inch-wide rubber tracks to traverse the terrain. The tracks allow the buggy to travel over soft ground such as sand and wet surfaces. The rubber track design increases the overall traction of the buggy.

Hand and foot controls are provided for ease of dumping and stopping of the power buggy. Multiple lift points have been provided to allow for easy access of a forklift when lifting is required.

A pivot dump feature has been added to allow the tub to be rotated either right or left when dumping of materials is required.

The WTB-16PD model is powered by a Honda GX690 air-cooled, gasoline engine rated at 22 hp at 3,600 rpm.

The engine drives a variable displacement hydrostatic axial piston pump.

The operator controls the forward and reverse machine travel by manually shifting the control levers which directs the hydraulic fluid flow to the drive motors. The fluid flow to the dump cylinder is controlled by a manually operated control valve.

This hydraulic system incorporates a closed loop configuration operating at a maximum of 4,300 psi (300 bar).

The hydraulic oil is filtered by a screen-type filter located in the hydraulic tank, then double-filtered within the system by a 10-micron cartridge spin-on return filter.

### WARNING

All operators must have training before operating the power buggy. For your safety, warnings are on the machine and in this manual. Failure to obey these warnings can cause **severe injury or even death**.

### CAUTION



**DO NOT** attempt to operate the power buggy until the Safety Information, General Information, and Inspection sections of this manual have been **read and thoroughly understood**.



# LIFTING AND TRANSPORTING

## LIFTING AND TRANSPORTING THE TRACK BUGGY

The following procedure describes how to lift and transport the track buggy.

### WARNING

**NEVER** lift the track buggy with personnel standing underneath the unit. **ALWAYS** clear the area of bystanders. **DO NOT** lift to unnecessary heights or with the tub loaded with material.

1. Place the tub/bucket in the dump position to gain access to the two lifting points.
2. Attach a strap or chain of appropriate lifting capacity to the lifting points as shown in Figure 2A.
3. Use a crane or forklift to hoist the track buggy onto a flatbed truck for transporting.
4. Attach tie-down straps/chains to the tie-down points on the track buggy as shown in Figure 2B.

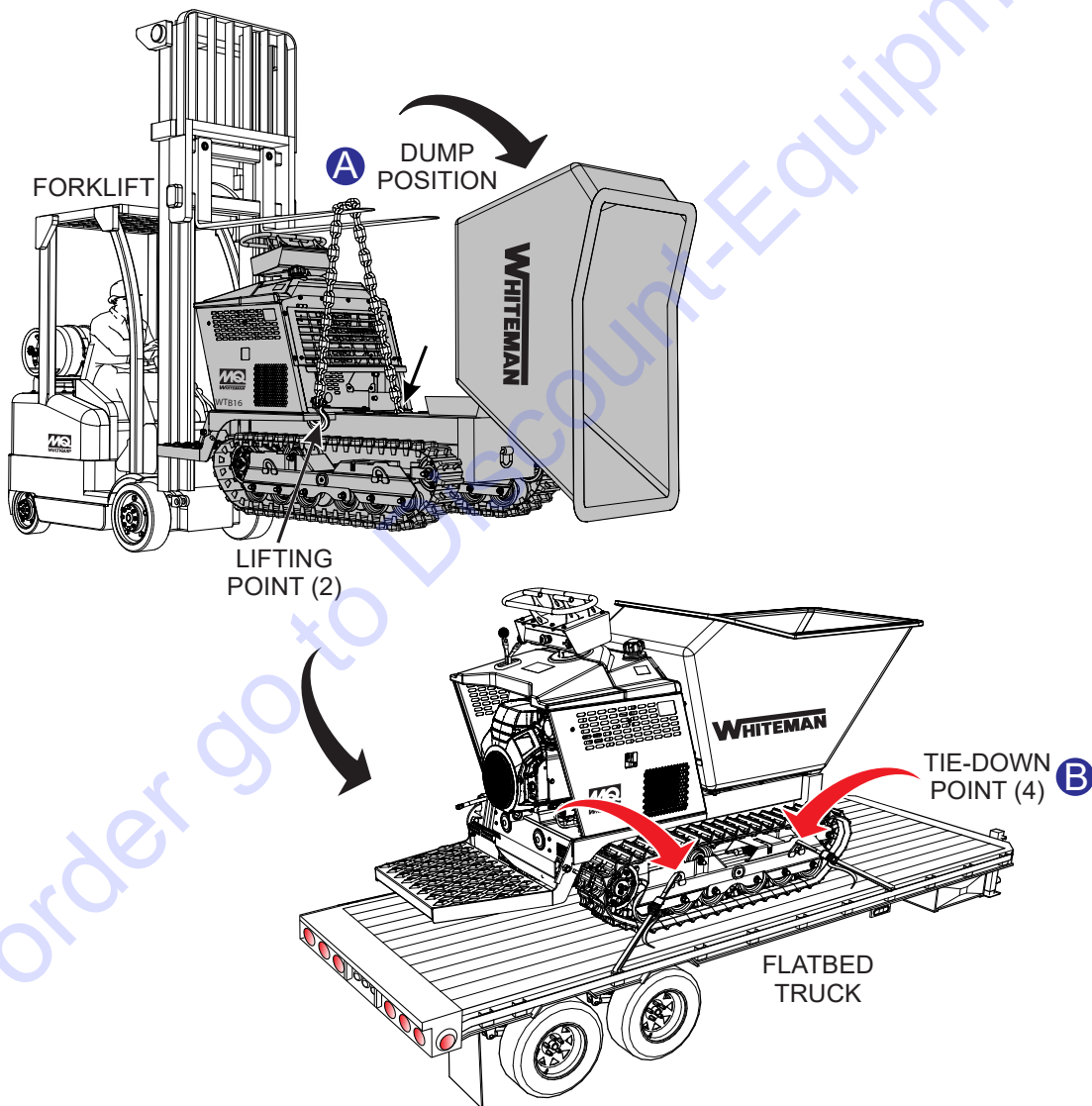

Figure 2. Lifting the Track Buggy

# BUGGY COMPONENTS

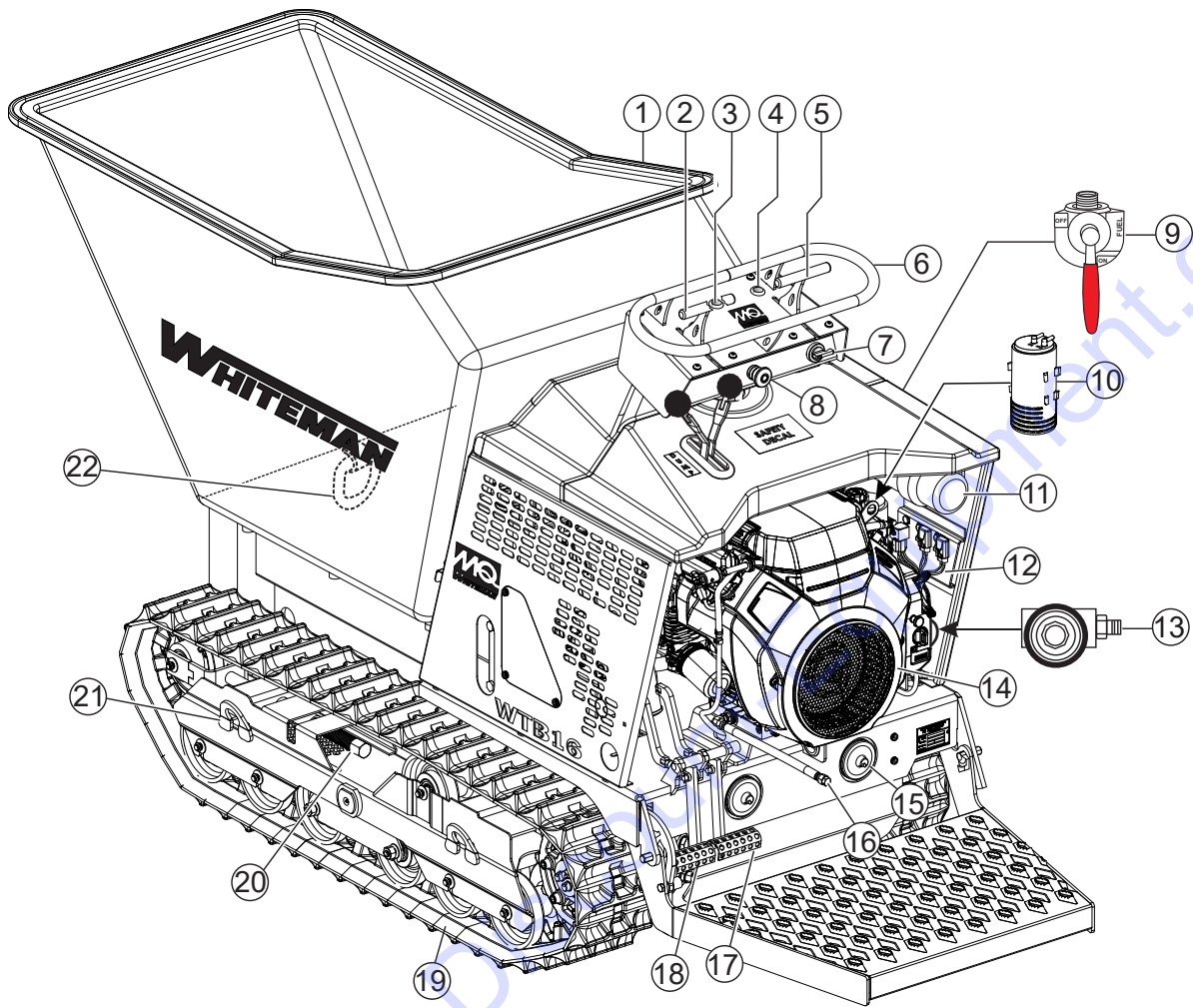

Figure 3. WTB-16PD Power Buggy Components 1

## BUGGY COMPONENTS

1. **Tub or Bucket** — Used for the transportation of material. Tub holds approximately 16 cubic feet (0.59 cubic yards) of water.
2. **Left Track Steering Lever** — Controls left side of track buggy. Reference Table 6 for directional positioning. Allows the buggy to move in either a forward or reverse direction.
3. **Brake Lamp** — When lit, indicates that the parking brake is set (**ON**).
4. **Oil Alert Lamp** — When lit, indicates low engine oil. This condition will cause the engine to shut down.
5. **Right Track Steering Lever** — Controls right side of track buggy. Reference Table 6 for directional positioning. Allows the buggy to move in either a forward or reverse direction.
6. **Handlebar** — Grip this handlebar with both hands when driving the buggy.
7. **Brake Switch Knob** — This switch sets and releases the parking brake.
8. **Emergency Stop Button** — In the event of an emergency, press this button to shut down the engine.
9. **Fuel Valve Lever** — When placed in the **ON** position fuel will flow. **OFF** position stops fuel flow. **ALWAYS** place this lever in the **ON** position when starting the engine.
10. **Charcoal Canister** — Charcoal-activated system that absorbs or traps fuel vapors. Basic component of evaporative emissions control systems.
11. **Documentation Canister** — Store and maintain Operation, Parts and Engine manuals in this container at all times.
12. **Relay/Fuse Panel** — Contains one relay (parking brake solenoid) and two fuses. The 5-amp fuse provides protection for the parking brake relay. The 15-amp fuse provides protection for the heat exchanger.
13. **Parking Brake Solenoid** — When activated, engages the parking brake.
14. **Engine** — This machine uses an electric start, 20 hp, Honda GX690 air-cooled gasoline engine.
15. **Hydraulic Oil Access Port** — There are **five** of these ports on the machine. Remove the access cover to clean out the hydraulic oil reservoir.
16. **Engine Oil Drain Plug** — Remove plug to drain engine crankcase oil.
17. **Tub Pivot Pedal** — Use this pedal to pivot the tub. Press down on the pedal to rotate tub to the **left**. Lift up on the pedal to rotate tub to the **right**.
18. **Dump Pedal** — Use this pedal to place the tub in the dump (vertical) position. Press the pedal a second time to return the tub to the travel (horizontal) position.
19. **Rubber Track** — Inspect track daily for wear and tear. **DO NOT** use the machine if the rubber track is damaged.
20. **Rubber Track Adjustment Bolt** — Use this bolt to adjust tension of the rubber track. Check tension daily.
21. **Tie-Down Hook** — When transporting of the buggy is required, attach a strap to these tie-down points (4).
22. **Towing Hook** — Use this hook to tow the buggy if it gets stuck on the job site. The machine must be placed in **free-wheel mode** before towing, otherwise damage to drive motors will occur. **DO NOT** tow on public roads

## BUGGY COMPONENTS CONT'D.

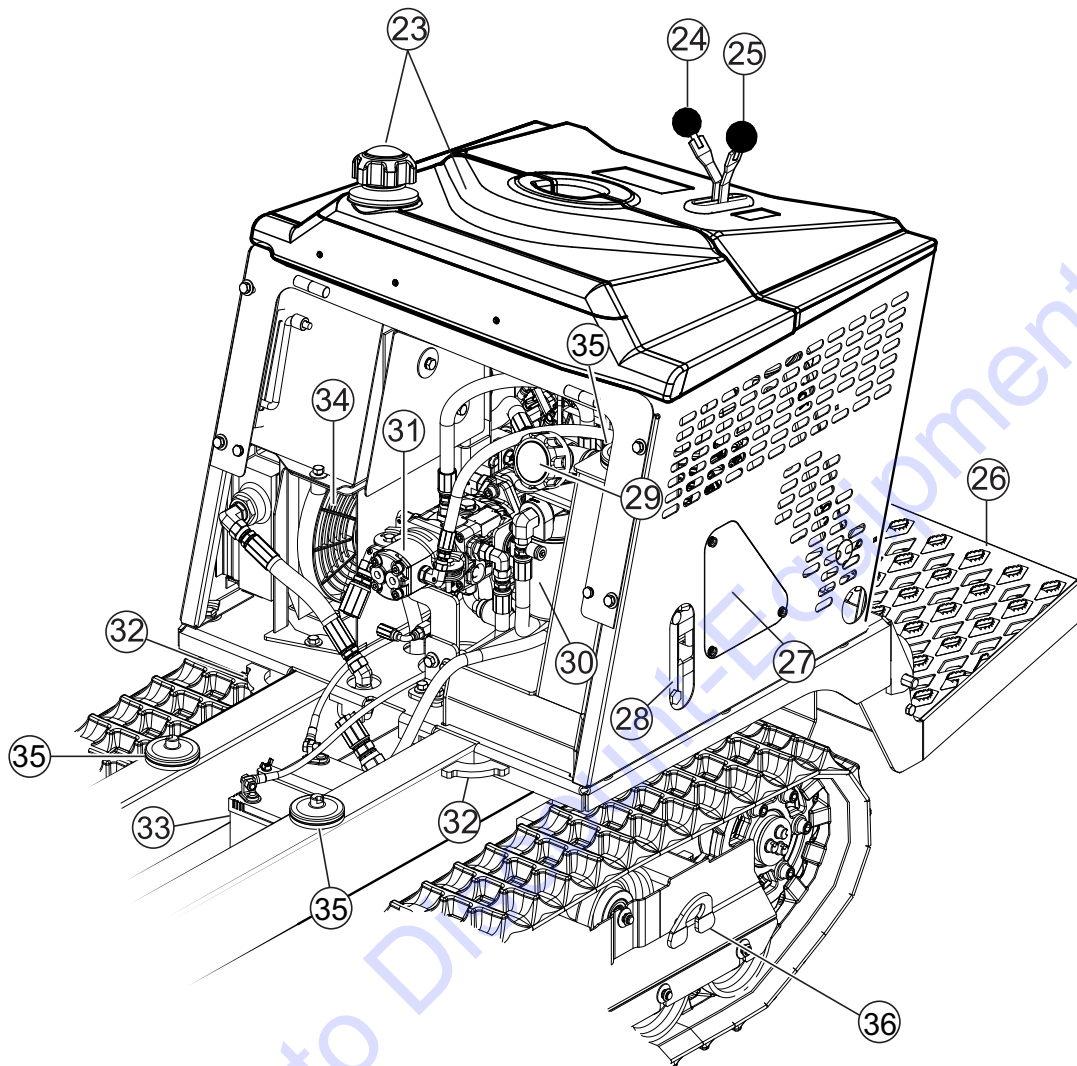

Figure 4. WTB-16PD Power Buggy Components 2

## BUGGY COMPONENTS CONT'D.

---

23. **Fuel Tank/Cap** — Remove this cap to add fuel. Tank holds approximately 5.0 U.S. gallons (20 liters). **DO NOT** overfill. Tighten the cap until you hear 'clicking.'
24. **Dump Control Lever** — Move this lever forward to place the tub in the dump (vertical) position. Move the lever backward to return the tub to the travel (horizontal) position.
25. **Tub Pivot Lever** — Use this lever to pivot the tub. Push the lever forward to rotate tub to the **left**. Push the lever backwards to rotate tub to the **right**.
26. **Operator Platform** — When the buggy is in use, the operator shall **ALWAYS** stand on this platform while holding onto the handlebar.
27. **Access Panel** — Remove this panel to gain access to the dump valve.
28. **Hydraulic Oil Sight Gauge** — Indicates the hydraulic oil level.
29. **Hydraulic Tank/Cap** — Remove this cap to add hydraulic oil. Tank holds approximately 5.3 U.S. gallons (20.4 liters). **DO NOT** overfill.
30. **Hydraulic Oil Filter** — Spin-on type filter, 10-micron. Filters out contaminants and debris.
31. **Tandem Hydraulic Pump** — Machine uses an axial displacement piston pump and gear pump.
32. **Lifting Hooks** — When lifting of the buggy is required, attach a strap/chain of adequate lifting capacity (3,000 lb./1,360 kg) to these two lifting points.
33. **Battery** — Always use gloves and eye protection when handling the battery.
34. **Heat Exchanger** — Provides cooling for the hydraulic fluid. Transfers heat from the fluid..
35. **Hydraulic Oil Access Port** — There are **five** of these ports on the machine. Remove the access cover to clean out the hydraulic oil reservoir.
36. **Tie-Down Hook** — When transporting of the buggy is required, attach a strap to these tie-down points (4).

# BASIC ENGINE COMPONENTS

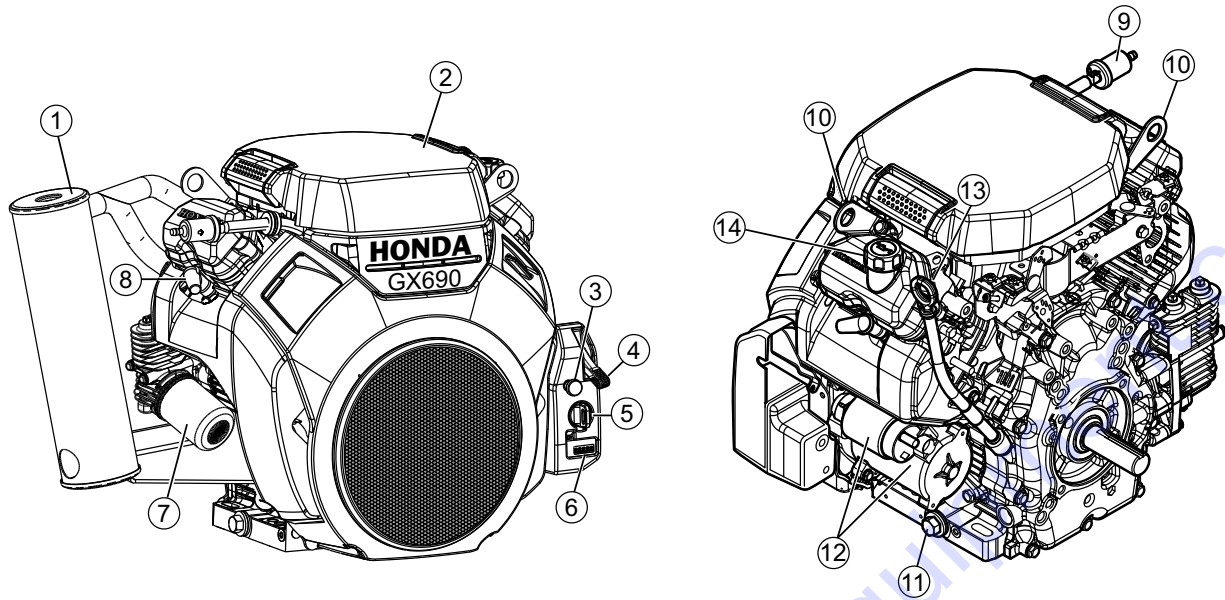

Figure 5. Honda GX690 Engine Components

## INITIAL SERVICING

The engine (Figure 5) must be checked for proper lubrication and filled with fuel prior to operation. Refer to the manufacturer's engine manual for instructions and details on operation and servicing.

1. **Muffler** — Used to reduce noise and emissions.

### ! WARNING



Engine components can generate extreme heat. To prevent burns, **DO NOT** touch these areas while the engine is running or immediately after operating. **NEVER** operate the engine with the muffler removed.

2. **Air Cleaner** — Prevents dirt and other debris from entering the fuel system. Unsnap the air filter cover to gain access to the filter element.
3. **Choke Knob** — Used in the starting of a cold engine or in cold weather conditions. The choke enriches the fuel mixture.
4. **Throttle Lever** — Regulates engine speed.
5. **Engine ON/OFF Switch** — 'ON' position permits engine starting, 'OFF' position stops engine operation.
6. **Hour Meter** — Indicates the number of hours the machine has been in use.

7. **Oil Filter** — Spin-on type, filters oil for contaminants.
8. **Spark Plug** — Provides spark to the ignition system. Set the spark plug gap to 0.70–0.80 mm (0.028–0.031 in.) Clean the spark plug once a week.
9. **In-Line Fuel Filter** — Filters fuel for contaminants.
10. **Engine Lifting Hook** — Attach a chain or rope to these lifting hooks when lifting of the engine is required.
11. **Engine Oil Drain Plug** — Remove this plug to drain engine crankcase oil.
12. **Starter/Solenoid** — Starts the engine when the ignition key is rotated to the 'ON' position.
13. **Engine Oil Dipstick** — Remove to check the amount and condition of oil in the crankcase.
14. **Engine Oil Filler Cap** — Remove to add engine oil.

### NOTICE

Operating the engine without an air filter, with a damaged air filter, or with a filter in need of replacement will allow dirt to enter the engine, causing rapid engine wear.

## BEFORE STARTING

1. Read safety information at the beginning of the manual.
2. Clean the machine, removing dirt and dust—particularly the engine cooling air inlet, carburetor and air cleaner.
3. Check the air filter for dirt and dust. If the air filter is dirty, replace it with a new one.
4. Check the carburetor for external dirt and dust. Clean with dry compressed air.
5. Check fastening nuts and bolts for tightness.

## ENGINE OIL CHECK

1. To check the engine oil level, place the buggy on secure, level ground with the engine stopped.
2. Remove the dipstick from its holder (Figure 6) and wipe it clean.

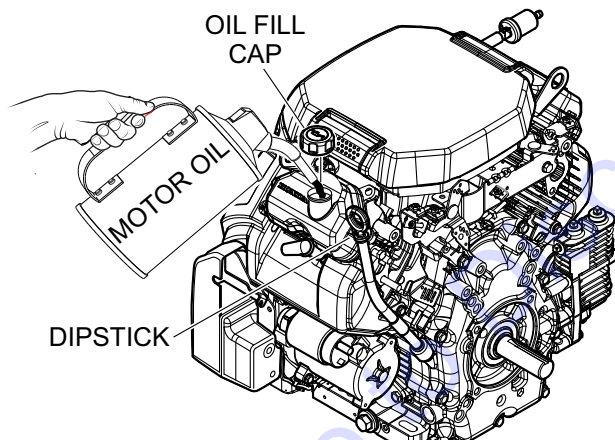

**Figure 6. Engine Oil Dipstick Removal**

3. Reinsert the dipstick back into its holder, then remove it again. Check the oil level shown on the dipstick.
4. If the oil level is low, remove the oil fill cap (Figure 6) and fill the engine crankcase with lubricating oil through the oil filler hole. **DO NOT** overfill.
5. Make sure the buggy is level and verify that the oil level is maintained between the two notches (Figure 7) as shown on the dipstick. Reference Table 5 for proper selection of engine oil.

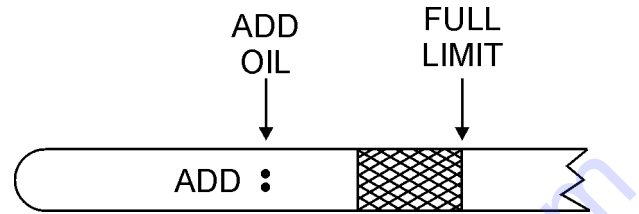

**Figure 7. Engine Oil Level**

6. When checking the engine oil, be sure to check if the oil is clean. If the oil is not clean, drain the oil by removing the oil drain plug, and refill with the specified amount of oil as outlined in the Maintenance section of this manual. Oil should be warm before draining.

**Table 5. Oil Type**

Season	Temperature	Oil Type
Summer	25°C or Higher	SAE 10W-30
Spring/Fall	25°C~10°C	SAE 10W-30/20
Winter	0°C or Lower	SAE 10W-10

## GASOLINE CHECK

**⚠ DANGER**

Motor fuels are highly flammable and can be dangerous if mishandled. **DO NOT** smoke while refueling. **DO NOT** attempt to refuel the buggy if the engine is **hot or running**.

1. Remove the fuel cap (Figure 8) located on top of the fuel tank.

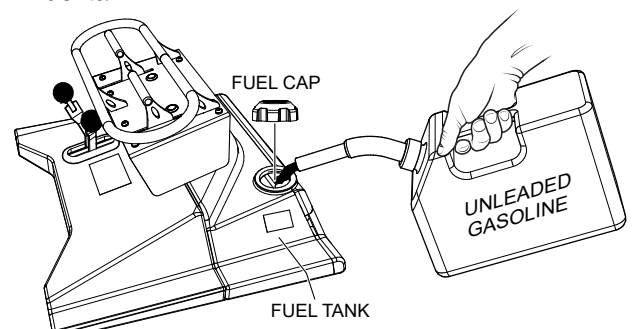

**Figure 8. Fuel Tank**

2. Visually inspect to see if the fuel level is low. If the fuel level is low, replenish with unleaded fuel.
3. When refueling, be sure to use a strainer for filtration. **DO NOT** top off fuel. Wipe up any spilled fuel immediately. Tighten the fuel cap until it clicks.

## BATTERY

This unit is of negative ground. **DO NOT** connect in reverse. **ALWAYS** maintain battery fluid level between the specified marks. Battery life will be shortened if the fluid levels are not properly maintained. Add only distilled water when replenishment is necessary. **DO NOT** overfill.

Check to see whether the battery cables are loose. Poor contact may result in poor starting or malfunctions.

**ALWAYS** keep the terminals firmly tightened. Coat the terminals with an approved battery terminal treatment compound. Replace the battery with only the recommended type battery. The battery type used in this power buggy is BCI Group U1.

The battery is sufficiently charged if the specific gravity of the battery fluid is 1.28 (at 68°F). If the specific gravity should fall to 1.245 or lower, it indicates that the battery is dead and needs to be recharged or replaced.

Before charging the battery with an external electric source, be sure to disconnect the battery cables.

### **CAUTION**

**ALWAYS** disconnect the negative terminal **FIRST** and reconnect negative terminal **LAST**.

## Battery Cable Installation

**ALWAYS** be sure the battery cables (Figure 9) are properly connected to the battery terminals as shown below. The **red cable** is connected to the positive terminal of the battery and the **black cable** is connected to the negative terminal of the battery.

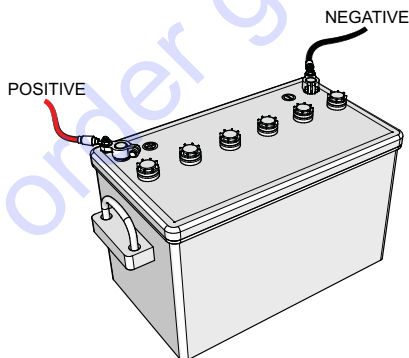

Figure 9. Battery Connections

When connecting the battery do the following:

1. **NEVER** connect the battery cables to the battery terminals when the ignition is in the **ON** (start) position.
2. Place a small amount of battery terminal treatment compound around both battery terminals. This will ensure a good connection and will help prevent corrosion around the battery terminals.

### **NOTICE**

If the battery cable is connected incorrectly, electrical damage to the power buggy will occur. Pay close attention to the polarity of the battery when connecting the battery.

### **CAUTION**

Inadequate battery connections may cause poor starting of the power buggy and create other malfunctions.

## RUBBER TRACK CHECK

The rubber tracks installed on the track buggy are very important for its effective operation.

1. **ALWAYS** check the rubber tracks (Figure 10) for cuts and abrasions.

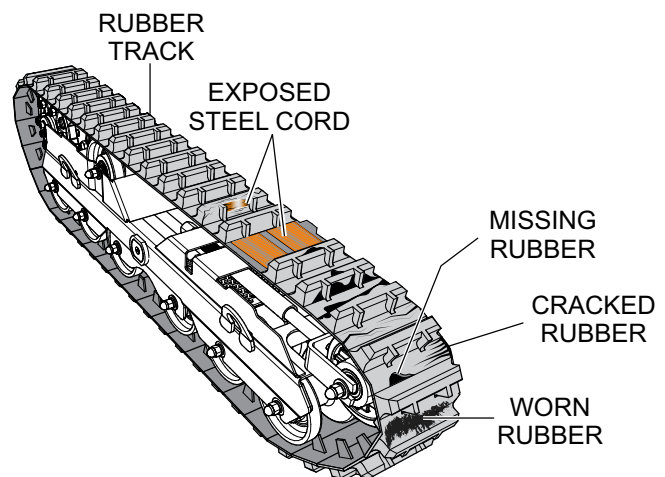

Figure 10. Rubber Track Inspection

2. **DO NOT** operate the track buggy if the rubber track is deformed or damaged.
3. Check the tension of the rubber track **every 50 hours**. Reference the Maintenance section in this manual on how to check rubber track tension.



## LINKAGE CHECK

Check and make sure that all linkages within the buggy are functioning correctly.

## DUMP CYLINDER CHECK

1. Check the power buggy's dump cylinder as outlined in the maintenance section of this manual.
2. Make sure that both Zerk fittings for the dump cylinder have been lubricated.

## HYDRAULIC OIL CHECK

1. Visually read the hydraulic sight glass (Figure 11) to see if the hydraulic oil level is low.
2. If the hydraulic oil is low, add enough hydraulic oil to bring the oil level to a normal, safe operating level.

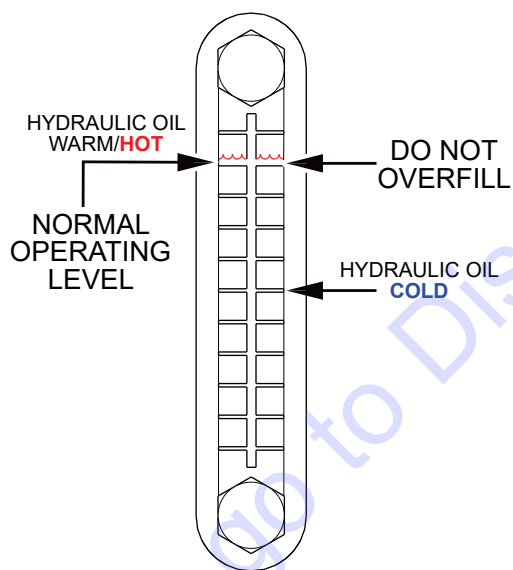

Figure 11. Hydraulic Sight Glass

## CAUTION



**DO NOT** attempt to operate the power buggy until the Safety Information, General Information, and Inspection sections of this manual have been **read and thoroughly understood**.

1. Before attempting to start the power buggy, make sure that the **emergency stop switch** (Figure 12) is not pushed in. The power buggy will not start with the emergency stop switch engaged. Pull the switch outward when starting the engine.

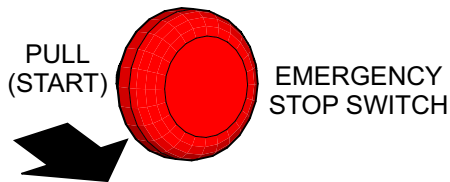

**Figure 12. Kill Switch (OFF)**

2. Place the fuel tank ON/OFF valve (Figure 13) in the **ON** position.

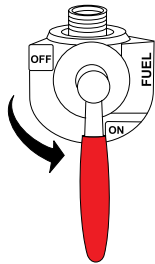

**Figure 13. Fuel Tank ON/OFF Valve (ON)**

3. If starting a cold engine, **pull** the choke lever outward (Figure 14) to the **CLOSED** position.

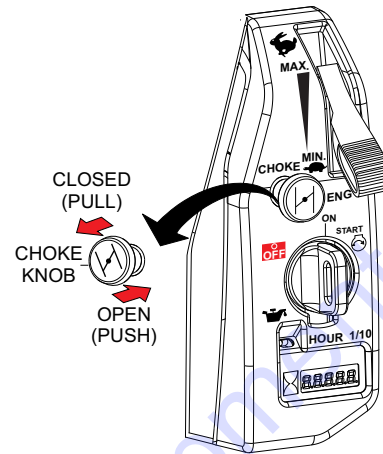
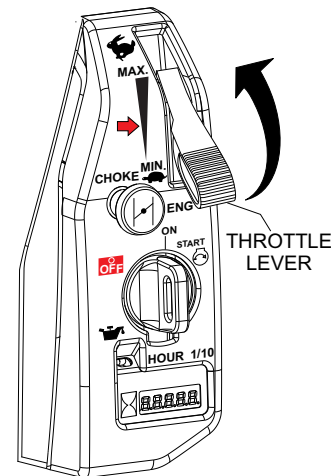

**Figure 14. Engine Choke Lever**

## NOTICE

The **CLOSED** position of the choke lever enriches the fuel mixture for starting a cold engine. The **OPEN** position provides the correct fuel mixture for normal operation after starting, and for restarting a warm engine.

4. If starting a warm engine or the temperature is warm, **push** the choke lever inward (Figure 14) to the **OPEN** position.
5. Move the throttle lever halfway between the **MIN.** and **MAX.** position (Figure 15) for starting.



**Figure 15. Throttle Lever**

- Place the ignition key (Figure 16) in the **START** position and hold it until the engine starts. When the engine starts, release the key, allowing it to return back to the **ON** position.

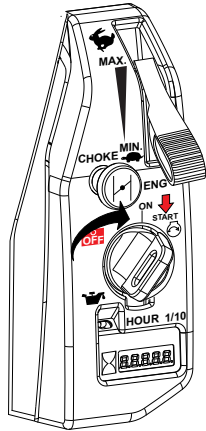
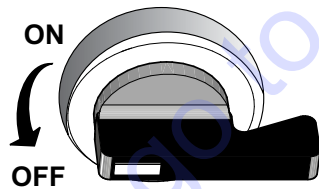

**Figure 16. Engine ON/OFF Switch (Start)**

- Run the engine for several minutes. Check for fuel leaks and noises that could be associated with a loose guard or cover.
- Before operating, place the choke lever (Figure 14) in the **OPEN** position.

## TRAVELING

- With the engine running, place the parking brake knob (Figure 17) in the **OFF** position.



**Figure 17. Brake Knob (Off Position)**

- Verify that the parking brake release lamp is **OFF**.



**Figure 18. Parking Brake Lamp (OFF)**

- Place the throttle lever (Figure 15) in the **MAX.** position.

- Push both the left and right track levers forward slowly. Notice that the track buggy begins to move in a forward direction.
- Practice maneuvering the track buggy using the information listed in Table 6.

**Table 6. Directional Positioning**

TRACK LEVER DIRECTION	RESULTS
<p>Move <b>LEFT</b> Track Lever Forward</p>	<p>Causes only the left-side of the buggy to move <b>forward</b>.</p>
<p>Move <b>LEFT</b> Track Lever Backward</p>	<p>Causes only the left-side of the buggy to move <b>backward</b>.</p>
<p>Move <b>RIGHT</b> Track Lever Forward</p>	<p>Causes only the right-side of the buggy to move <b>forward</b>.</p>
<p>Move <b>RIGHT</b> Track Lever Backward</p>	<p>Causes only the right-side of the buggy to move <b>backward</b>.</p>
<p>Move <b>BOTH</b> Track Levers Forward</p>	<p>Causes the buggy to move <b>forward</b> in a straight line.</p>
<p>Move <b>BOTH</b> Track Levers Backward</p>	<p>Causes the buggy to move <b>backward</b> in a straight line.</p>

### CAUTION

**DO NOT** steer the buggy left or right when traveling up or down on a grade. Travel in a straight path.

### CAUTION

Avoid sudden or quick turns. **ALWAYS** face the controls when traveling.

# OPERATION

When traveling on a slope, it is necessary to determine the grade of the path. The WTB-16 can travel up or down a maximum grade of 20% (12°). **DO NOT** travel on steeper slopes.

To determine the % grade of your path of travel, use the formula and graphs as shown in Figure 19.

## NOTICE

When traveling on slopes with a loaded tub, ensure the tub is positioned on the **uphill** end of the buggy, and the operator is on the **downhill** end of the buggy (Figure 20).

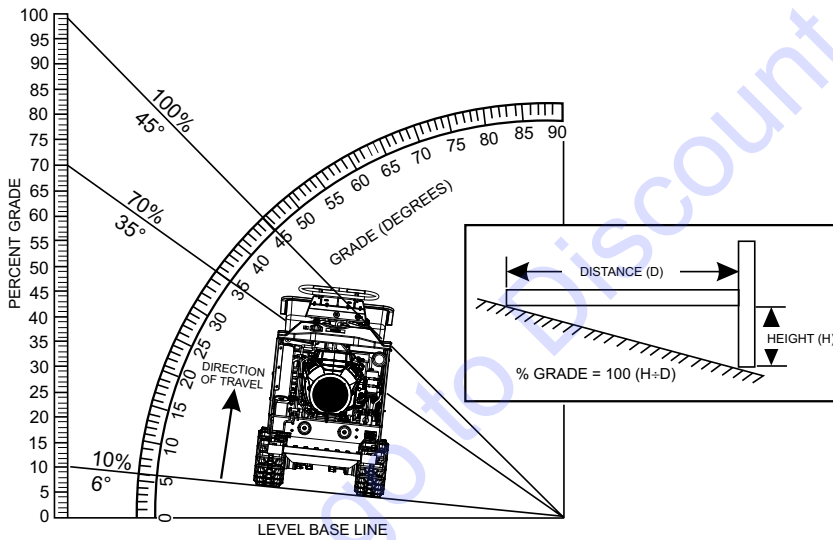
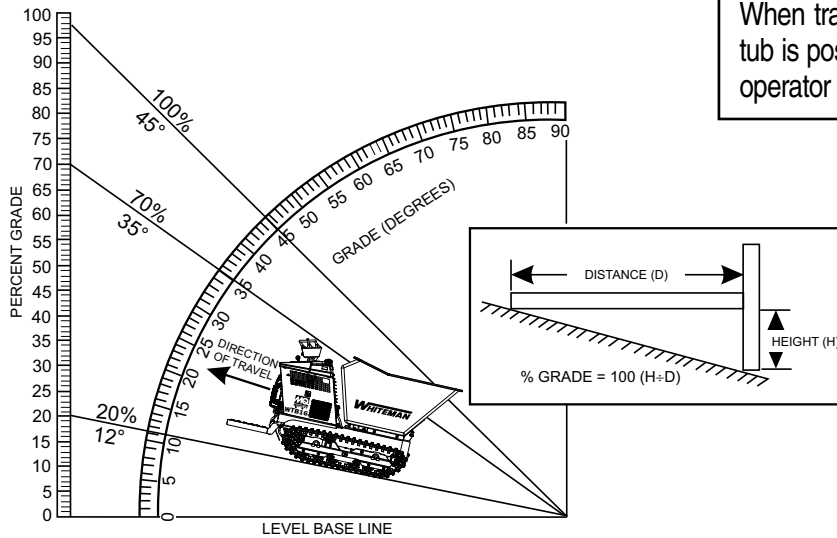
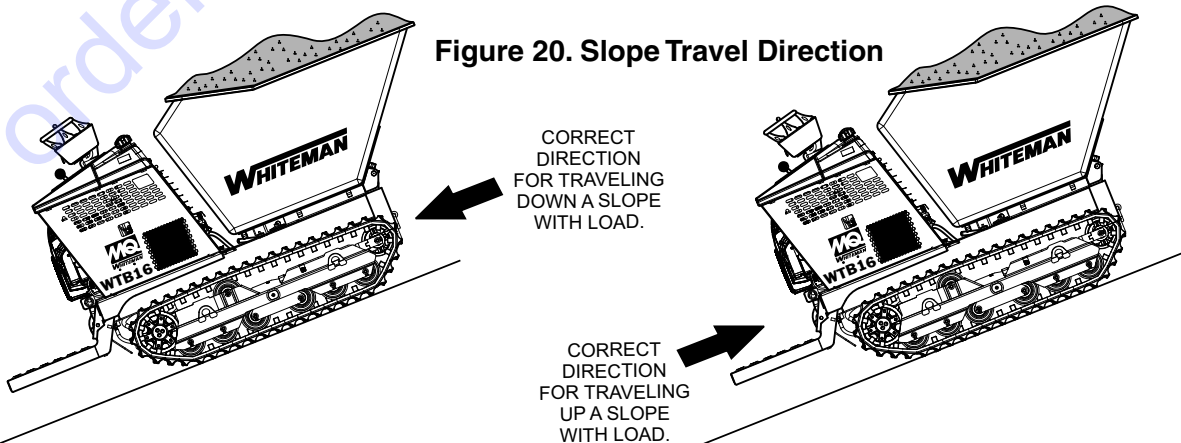

Figure 19. Determining Grade of Slope

Figure 20. Slope Travel Direction



## TUB (BUCKET) DUMPING

### **WARNING**

**DO NOT** activate the dump mechanism (tub/bucket) if the buggy is facing downhill. The possibility exists of the buggy tipping over causing equipment damage and **severe bodily harm**.

### **NOTICE**

Releasing either one (dump control lever or pedal) before dump is completed will cause the tub to return to the horizontal position.

The hydraulic dump can be controlled by the hand dump control lever or foot dump pedal.

1. To place the tub in the **vertical** position, press down on the dump pedal (Figure 21A) or move the dump control lever forward (Figure 21B). The tub will move to the vertical position as long as pressure is continuously applied to the dump pedal or the dump control lever is held in the forward position.
2. To return the tub to the **horizontal** position, simply place your foot underneath the dump pedal (Figure 21C) and lift or pull back on the dump control lever (Figure 21D).

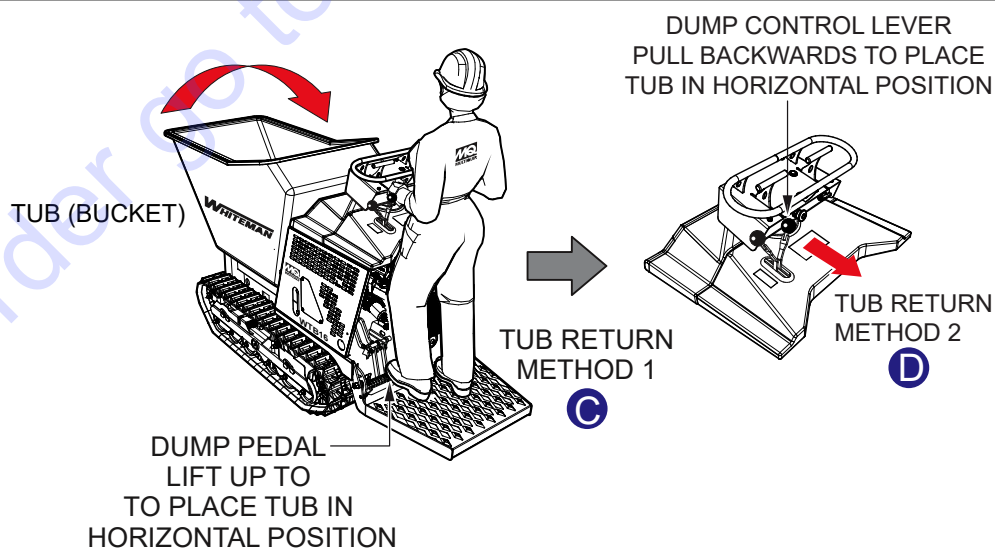
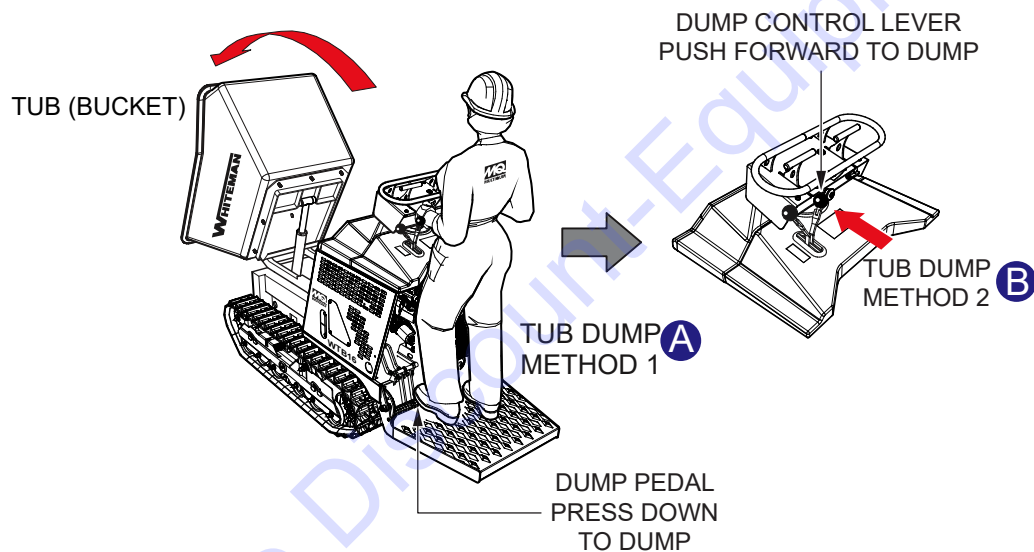

Figure 21. Tub Dumping

## TUB PIVOT

The hydraulic tub pivot can be controlled by either the hand pivot control lever or the foot pivot pedal.

1. To rotate the tub to the left, push the lever forward (Figure 22A) or press down on the pivot pedal (Figure 22B).

2. To rotate the tub to the right, pull back on the lever (Figure 22C) or push upwards on the pivot pedal (Figure 22D).

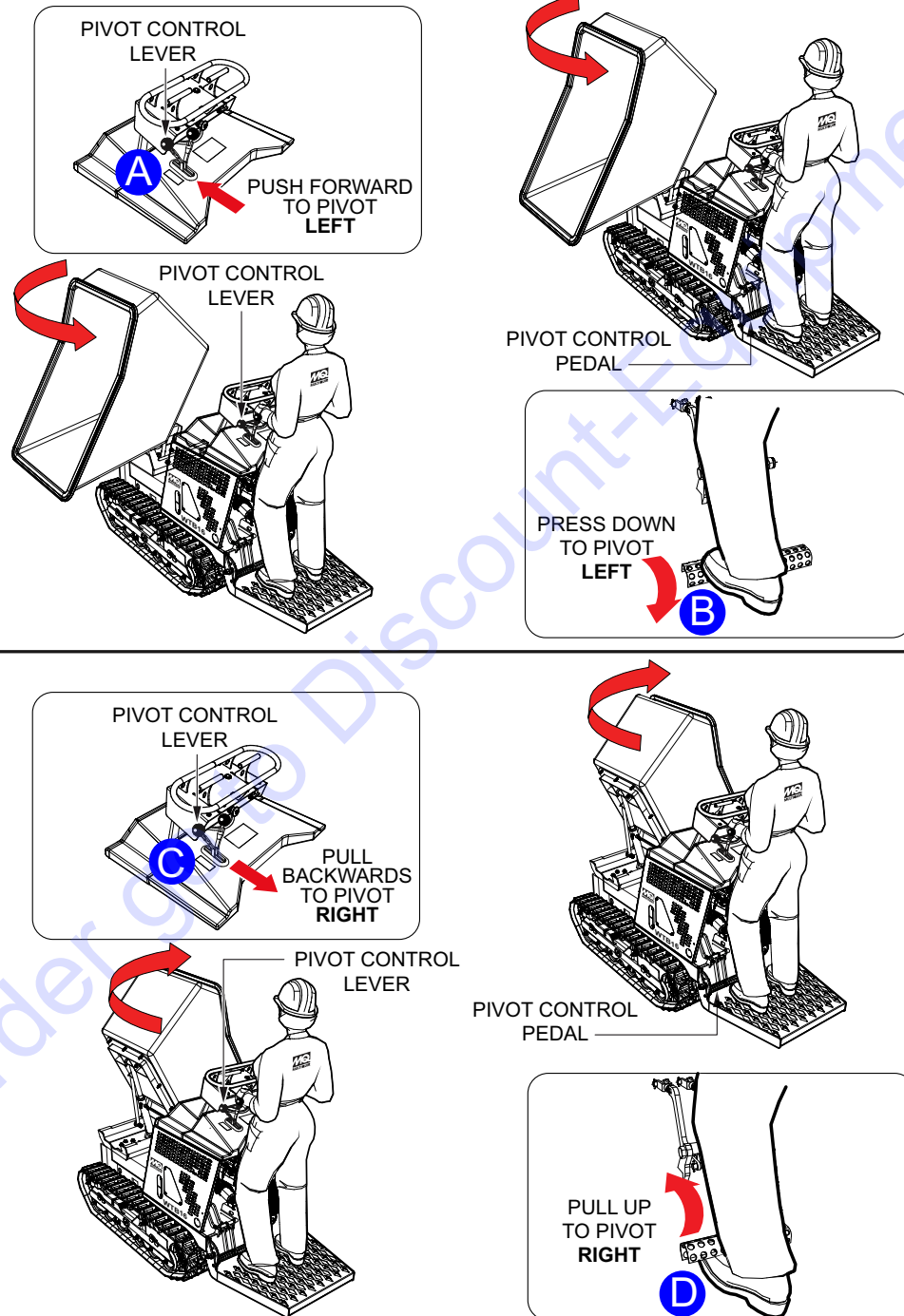
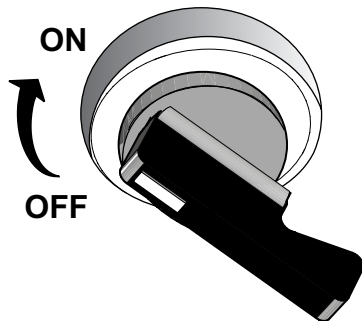

Figure 22. Tub Pivot

## SHUTDOWN (NORMAL)

Correct shutdown is important for safe operation. Follow these general steps:

1. Come to a full stop.
2. Place the parking brake knob in the **ON** position (brake set).



**Figure 23. Brake Knob (ON Position)**

3. Verify that the parking brake lamp is lit (**ON**).



**Figure 24. Parking Brake Lamp (ON)**

4. Place the throttle lever (Figure 15) in the slow position. Idle the engine 3–5 minutes for gradual cooling.
5. Place the ignition switch key in the **OFF** position.

6. Place the fuel valve lever (Figure 25) in the **OFF** position.

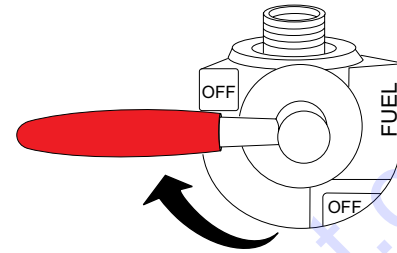

**Figure 25. Fuel Tank ON/OFF Valve (OFF)**

7. Cycle the hydraulic controls to eliminate residual pressure.
8. Remove the ignition key.

## EMERGENCY SHUTDOWN

This power buggy is equipped with a safety kill switch. This switch is located on the right side of the handlebar.

1. Push the **EMERGENCY STOP** switch (Figure 26).

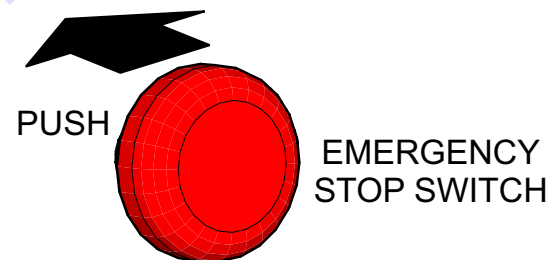

**Figure 26. Emergency Stop Switch (Push)**

# MAINTENANCE

**Table 7. Engine Maintenance Schedule**

DESCRIPTION (3)	OPERATION	BEFORE EACH USE	FIRST MONTH OR 25 HRS.	EVERY 6 MONTHS OR 100 HRS.	EVERY YEAR OR 300 HRS.	EVERY 2 YEARS OR 500 HRS.
Engine Oil	Check	X				
	Change		X	X		
Engine Oil Filter	Replace	Every 100 hrs.				
Air Cleaner	Check	X				
	Clean		X (1)			
	Change			X		X (*)
Spark Plugs	Check/Adjust			X		
	Replace				X	
Cooling Fins	Clean			X		
Fuel Filter	Replace				X (2)	
Fuel Tube	Check	Every 2 years (replace if necessary) (2)				

\* - Replace the paper filter element only.

(1) Service more frequently when used in **DUSTY** areas.

(2) These items should be serviced by your service dealer, unless you have the proper tools and are mechanically proficient. Refer to the **Honda Shop Manual** for service procedures.

(3) For commercial use, log hours of operation to determine proper maintenance intervals.

**Table 8. Power Buggy Maintenance Schedule**

Check Item	OPERATION	DAILY	Periodic Maintenance Interval			
			Every 25 Hrs	Every 50 Hrs	Every 100 Hrs	Every 500 Hrs
Dump Cylinder	Grease			X		
Swivel Wheels Shaft	Grease			X		
Tub Bearing Pivot Block	Grease			X		
Tub	Clean	X				
Tub for Cracks/Deformations	Check			X		
Rubber Track for Severe Cuts/Wear	Check	X				
Hydraulic Oil	Check	X			1st time	X
Hydraulic Oil Level	Check/Replace	X				X
Parking Brake	Check	X				
Fastners	Check	X				



When performing any maintenance on the power buggy or engine, follow all safety messages and rules for safe operation stated at the beginning of this manual.

## WARNING



Accidental starts can cause **severe injury or death**.



**ALWAYS** place the ON/OFF switch in the **OFF** position.



Disconnect and ground spark plug leads and disconnect the negative battery cable from the battery before servicing.

## WARNING



Some maintenance operations may require the engine to be running. Ensure that the maintenance area is well ventilated. Exhaust contains poisonous carbon monoxide gas that can cause unconsciousness and may result in **DEATH**.

## CAUTION



**ALWAYS** allow the engine to cool before servicing. **NEVER** attempt any maintenance on a hot engine.

## NOTICE

Operating the engine with a blocked filter screen, dirty or plugged cooling fins, and/or cooling shrouds removed will cause engine damage due to overheating.

## DANGER

**DO NOT** use gasoline as a cleaning solvent to avoid creating the risk of fire or an explosion.

## AIR CLEANER (100 HOURS)

Thoroughly remove dirt and oil from the engine and control area. Clean or replace the air cleaner elements as necessary. Check and retighten all fasteners as necessary.

1. Release the latch tabs (Figure 27) on each side of the air cleaner cover and remove the cover.

## NOTICE

Operating the engine with loose or damaged air cleaner components could allow unfiltered air into the engine, causing premature wear and failure.

## CAUTION



Wear protective equipment such as approved safety glasses or face shields and dust masks or respirators when cleaning air filters with compressed air.

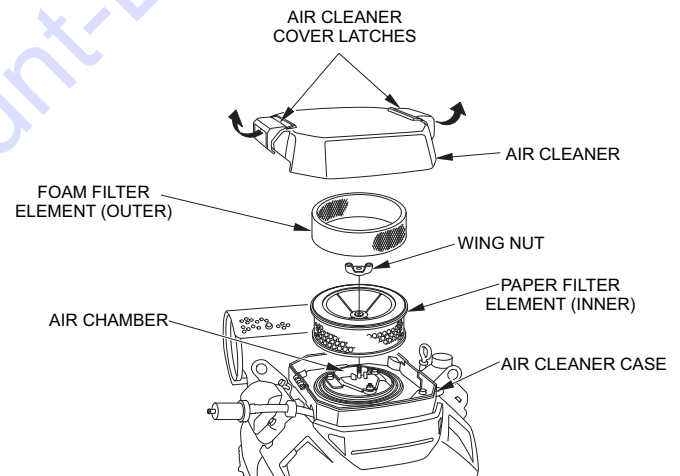
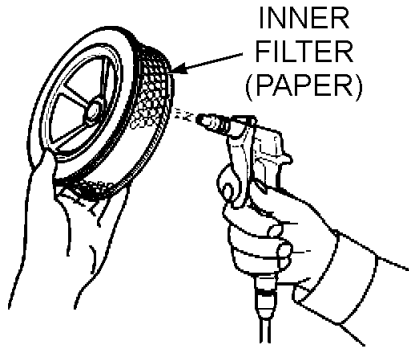

Figure 27. Air Filter Components

2. Remove the wing nut from the paper filter element.
3. Remove the **outer** foam filter.
4. Remove the **inner** paper filter.
5. Inspect both air filter elements and replace them if necessary.

# MAINTENANCE

- To clean the paper air filter (Figure 28), tap the filter element several times on a hard surface to remove dirt, or blow compressed air [not to exceed 30 psi (207 kPa, 2.1 kgf/cm<sup>2</sup>)] through the filter element from the air cleaner case side.



**Figure 28. Cleaning Inner Paper Filter**

- NEVER!** try to brush off dirt; brushing will force dirt into the fibers. If the paper element is excessively dirty, replace the element.
- Clean the foam air filter (Figure 29) element in warm, soapy water, rinse and allow to dry thoroughly, or clean with a nonflammable solvent and allow to dry. **DO NOT** pour any type of oil into the foam element.

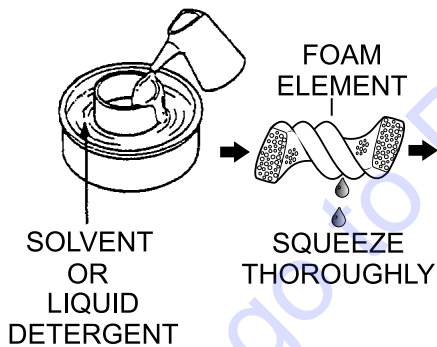
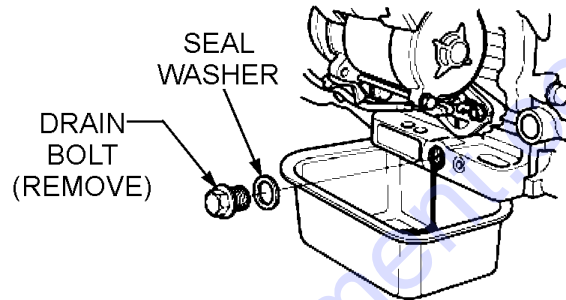

**Figure 29. Cleaning Foam Element**

- Wipe dirt from the inside of the air cleaner body and cover using a moist cloth. Be careful not to let any dirt or debris enter the air chamber that leads to the carburetor.
- Reinstall the foam air filter element to the air cleaner cover, then reinstall the paper air filter element and cover to the air cleaner case. Securely latch the hook tabs onto the air cleaner cover.

## CHANGING ENGINE OIL (100 HOURS)

- Drain the engine oil into a suitable container when the oil is warm as shown in Figure 30.

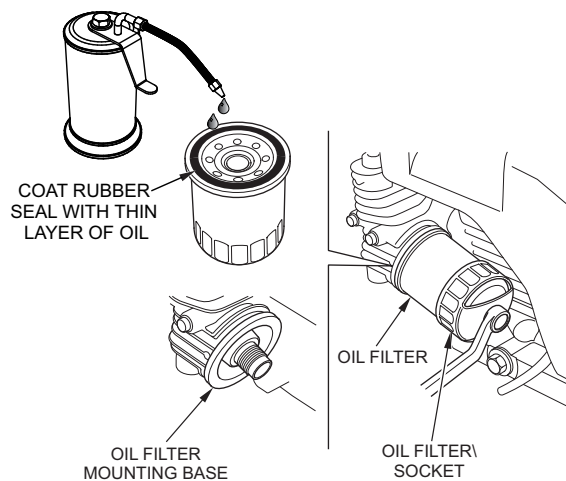

**Figure 30. Draining Engine Oil**

- Remove the oil drain bolt and sealing washer and allow the oil to drain into a suitable container.
- Reinstall the drain bolt with sealing washer and tighten securely.
- Replace engine oil with the recommended type oil as listed in Table 5. For engine oil capacity, see Table 3. **DO NOT** overfill.

## OIL FILTER (200 HOURS)

- Replace the engine oil filter (Figure 31) every 200 hours.



**Figure 31. Oil Filter**

- Use an oil filter socket and remove the oil filter.
- Clean the area around the oil filter mounting base.

4. Coat the rubber seal (gasket) surface of the oil filter with clean 15W-40 engine oil. See Figure 31.
5. Install the new oil filter first by hand until it makes contact with the filter head surface. Tighten it another 3/4 turn using the filter socket. Tightening torque is 12 N·m (1.2 kgf·m, 9 lbf·ft).

## IN-LINE FUEL FILTER (200 HOURS)

1. Place the fuel tank ON/OFF valve lever (Figure 32) in the **OFF** position.

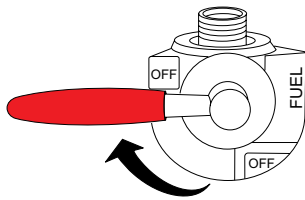

**Figure 32. Fuel Tank Valve Lever (OFF)**

2. Replace the engine in-line fuel filter (Figure 33) every 200 hours. When replacing the filter pay close attention to the orientation of the arrows.

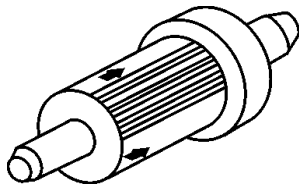

**Figure 33. In-Line Fuel Filter**

3. Return the fuel tank ON/OFF valve (Figure 34) to the **ON** position.

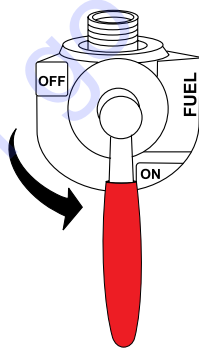

**Figure 34. Fuel Tank Valve Lever (ON)**

## Oil and Fuel Lines

- Check the oil and fuel lines and connections regularly for leaks or damage. Repair or replace as necessary.
- Replace the oil and fuel lines every two years to maintain the lines' performance and flexibility.

## SPARK PLUG ADJUSTMENT

1. Make sure the engine is cool before servicing the spark plugs.
2. Disconnect the spark plug caps. Check for dirt and remove any dirt from around the spark plug area.
3. Remove the spark plugs with a 5/8-inch spark plug wrench.
4. If the spark plugs are damaged, the sealing washer is in poor condition or the electrode is worn, replace the spark plugs.
5. Measure the spark plug electrode gap (Figure 35) with a wire-type feeler gauge. If needed, adjust the gap to 0.70–0.80 mm (0.028–0.031 in.) by carefully bending the side electrode.

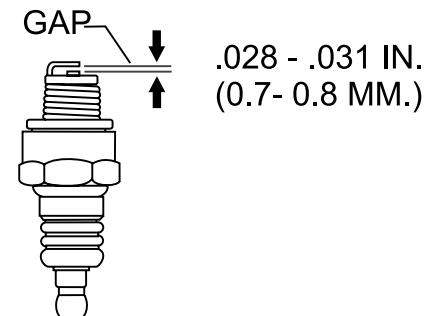

**Figure 35. Spark Plug Gap**

6. Install the spark plug carefully, by hand, to avoid cross-threading.
7. After the spark plug is seated, tighten with a 5/8-inch spark plug wrench to compress the sealing washer.
8. When installing a new spark plug, tighten 1/2 turn, after the spark plug seats, to compress the washer.
9. When reinstalling the original spark plug, tighten 1/8 to 1/4 turn after the spark plug seats to compress the washer.
10. Reattach the spark plug caps.

## ENGINE TUNE-UP

See your engine manual for specific information on tuning up your engine, checking and gapping the spark plugs, etc.

### NOTICE

See the engine manual supplied with your machine for an appropriate engine maintenance schedule and a troubleshooting guide for problems.

## ADDING HYDRAULIC OIL

1. Check the hydraulic oil level in the hydraulic oil tank by reading the hydraulic oil sight glass (Figure 36) mounted on the hydraulic oil tank.

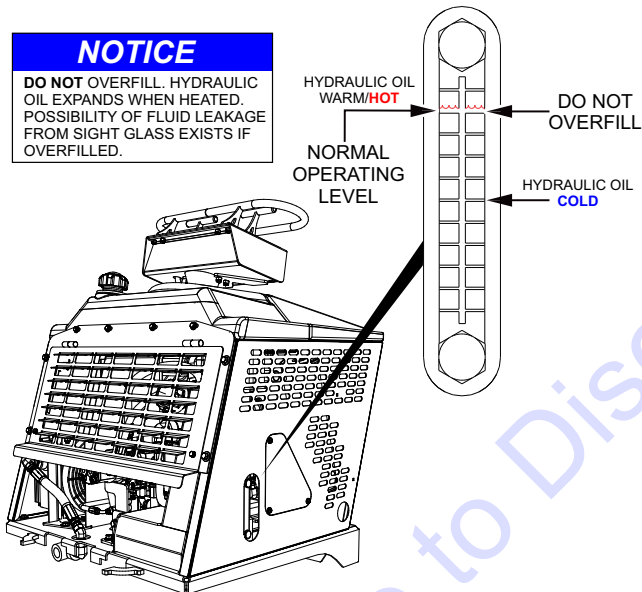

**Figure 36. Hydraulic Oil Sight Glass**

2. If the hydraulic oil level is low, fill to the proper level with EXXON/MOBIL NUTO H68 or equivalent.
3. To gain access to the hydraulic oil tank filler hole, the tub (Figure 37) must be placed in the dump (vertical) position.
4. Start the engine as outlined in the starting procedure, then place the tub in the dumping position.

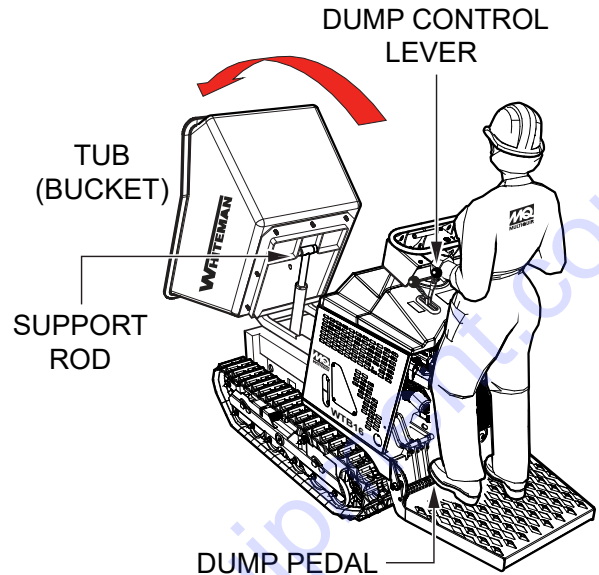

**Figure 37. Tub Dump Position Hydraulic Oil Access**

5. Use the tub support rod to support the tub, then turn the engine **OFF**.
6. Remove the two bolts that secure the access cover (Figure 38) to the buggy frame.

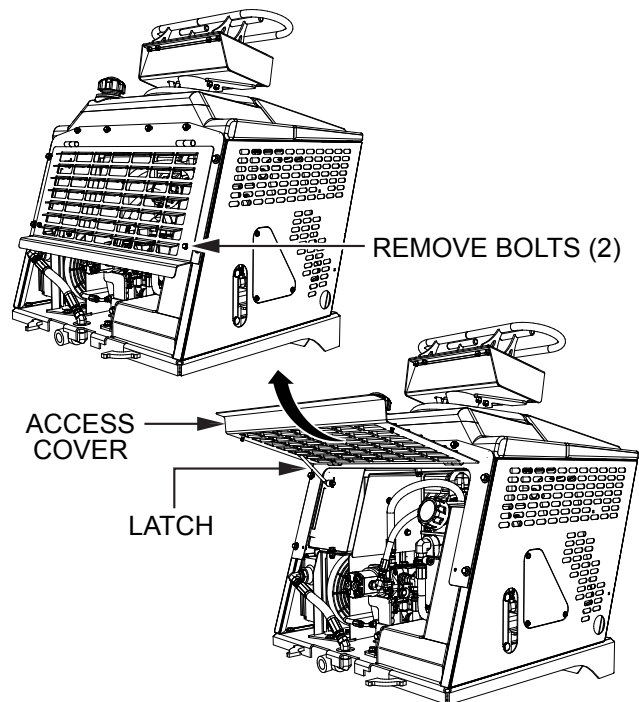

**Figure 38. Access Cover**

7. Lift up on the access door and secure the latch (Figure 38).

8. Remove the hydraulic oil filler cap (Figure 39) and add hydraulic oil as required. Fill to the normal operating mark as indicated on the hydraulic oil sight gauge.

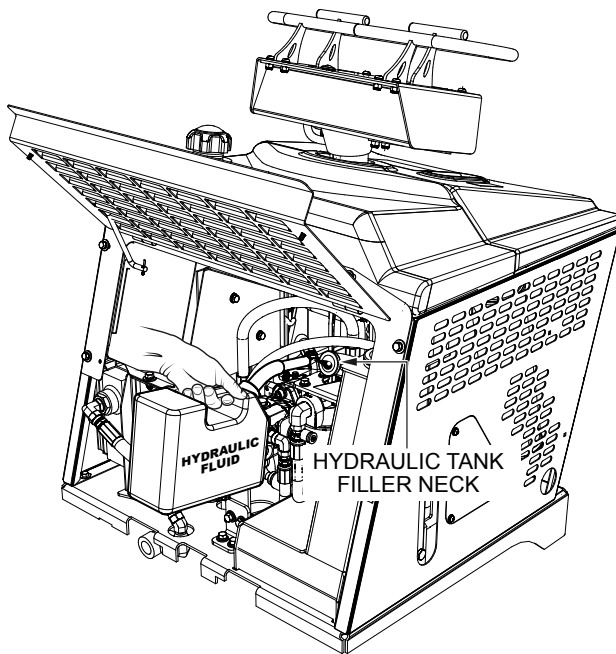

**Figure 39. Adding Hydraulic Oil**

### NOTICE

In climates where temperatures are below 35°F (1.6°C), hard starting may occur. In these cases, the hydraulic oil should be switched to a thinner 15weight hydraulic fluid.

9. Replace hydraulic oil after every 500 hours of operation. The reservoir capacity is 5.3 gallons (20.4 liters). The hydraulic oil filter should be changed each time the hydraulic oil is changed.

## HYDRAULIC OIL FILTER REPLACEMENT

1. Replace the hydraulic oil filter (Figure 40A) every 500 hours. Replace with only the recommended type filter.

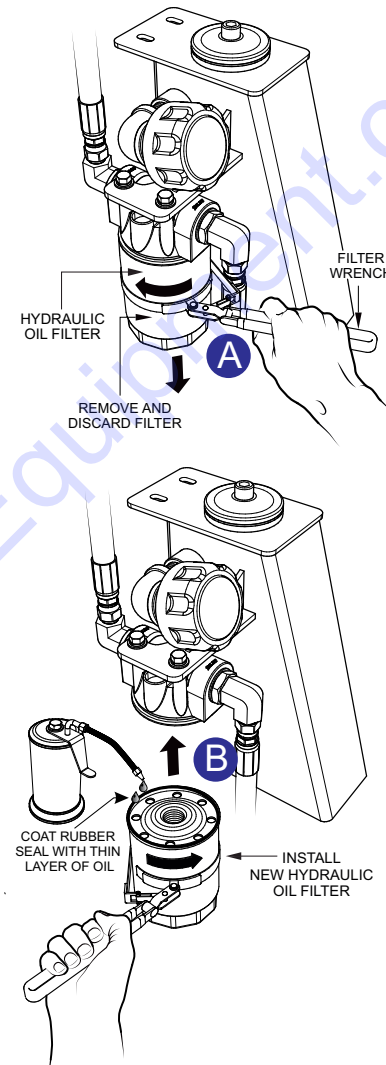

**Figure 40. Hydraulic Oil Filter**

2. Using an oil filter wrench (Figure 40A), remove the hydraulic oil filter.
3. Clean the area around the lubricating hydraulic oil filter head.
4. Coat the rubber seal (gasket) surface of the oil filter (Figure 40B) with clean 15W-40 engine oil.
5. Install the new hydraulic oil filter first by hand until it makes contact with the filter head surface. Tighten it another 3/4 turn using the filter wrench.
6. Run the system and check for leaks.

## HYDRAULIC DRIVE MOTORS

The hydraulic drive motors (Figure 41) are extremely reliable and will not need maintenance or repair under normal conditions.

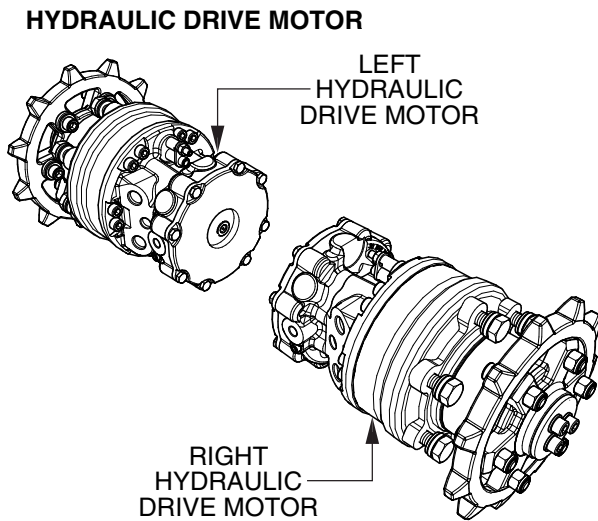

Figure 41. Hydraulic Drive Motor

### NOTICE

Contact Discount-equipment should any problems develop with the hydraulic drive motors.

## CHASSIS LUBRICATION

This power buggy is equipped with **six** Zerk fittings (Figure 42). Lubricate these Zerk fittings each day before operating the buggy.

- Lubricate with high-grade chassis lubricant at all lubricating points listed below:
  - **Tub Bearing Pivot Blocks (Underside of Tub)** — Two Zerk fittings on both sides of the machine (Figure 42A).
  - **Dump Cylinder Pivots** — Two Zerk fittings, top and bottom of dump cylinder (Figure 42B).
  - **Swivel Wheels** — Two Zerk fittings, both sides of machine (Figure 42C).

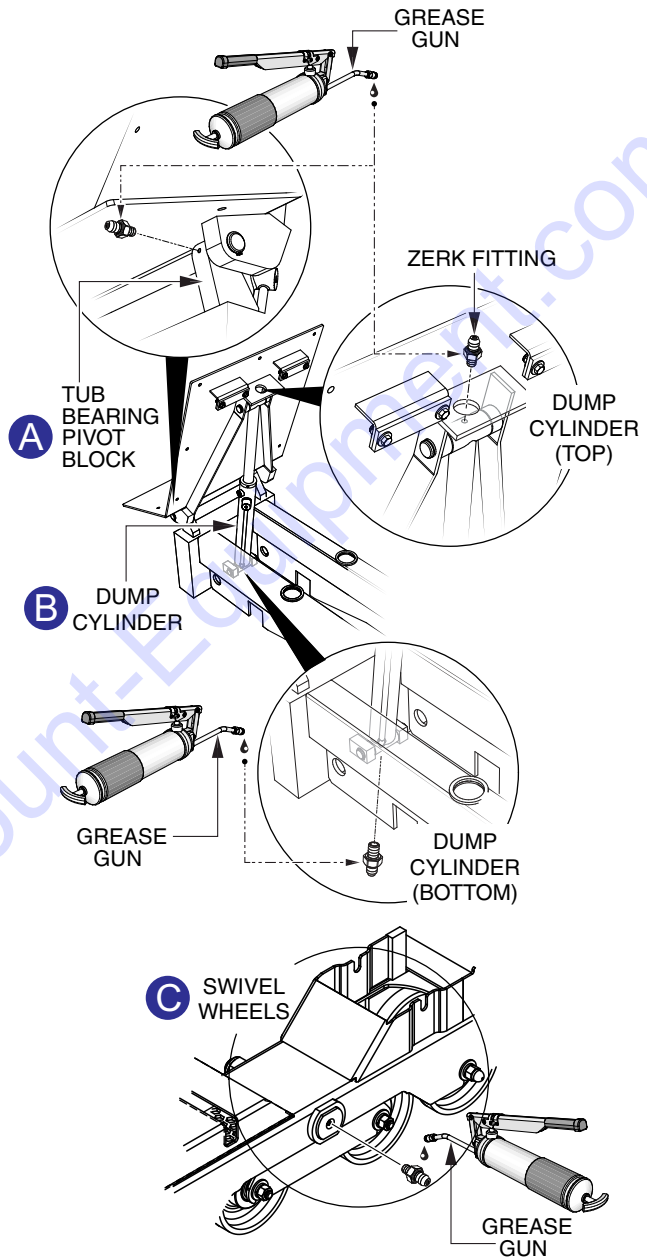

Figure 42. Lubrication Points

## PRESSURE TESTING

To ensure optimal performance of your track buggy, hydraulic pressure checks should be performed periodically. The following hydraulic pressure checks should be checked:

- Dump/Pivot Valve Pressure
- Charge Pressure (Return)
- Left-Side Hydraulic Motor (Forward/Reverse)
- Right-Side Hydraulic Motor (Forward/Reverse)

Multiquip offers a 'Special Test Pressure Gauge Kit.' When installed, the disconnection of hydraulic hoses is no longer required.

Simply unscrew the protective cap and insert the pressure gauge into the test port. Installation of the test pressure kit makes pressure testing quick and easy.

### Charge Pressure (Return)

1. To gain access to the hydraulic oil filter, place the tub in the dump (vertical) position.
2. Lift up on the access panel to gain entry to the pump and hydraulic compartment area. Secure the access panel with the latch.
3. Remove the hydraulic hose connected to the 90° fitting from port A on the dump/pivot valve (Figure 44A).
4. Insert the T-fitting and gauge into the 90° fitting.
5. Start the engine. Prior to testing, warm the hydraulic system oil until it reaches 100°F.
6. Increase engine RPMs to **high** speed. The test gauge should read 215–216 psi (14–15 bar).

### Hydraulic Drive Motors

1. Place the parking knob in the **ON** position (brake set).
2. Locate the left and right track hydraulic drive motors at the bottom front of the machine.
3. Remove the hydraulic hose connected to the 90° fitting (Figure 44B) from port A (top) on the hydraulic pump (pump 1). This port is for the **left-side** hydraulic drive motor **reverse** direction. Refer to the hydraulic diagram.
4. Insert the test gauge into the 90° fitting (top).
5. Start the engine and run at **high speed**. Momentarily push the travel lever to full travel for a few seconds, just long enough to read the test gauge. The value should read 4,350 psi (300 bar).

6. Stop the engine.
7. Reconnect the hydraulic hose back onto the 90° fitting, port A (top).
8. Remove the hydraulic hose connected to the 90° fitting (Figure 44B) from port B (bottom) on the hydraulic pump. This port is for the **left-side** hydraulic drive motor **forward** direction.
9. Insert the test gauge into the 90° fitting port B (bottom).
10. Start the engine and run at **high speed**. The test gauge should read 4,350 psi (300 bar).
11. Stop the engine.
12. Reconnect the hydraulic hose back onto the 90° fitting, port B (bottom).
13. Repeat this procedure for the **right-side** hydraulic drive motor (hydraulic pump 2).

### Dump Valve Pressure

1. To gain access to the dump/pivot valve, remove the three screws that secure the access cover to the panel.

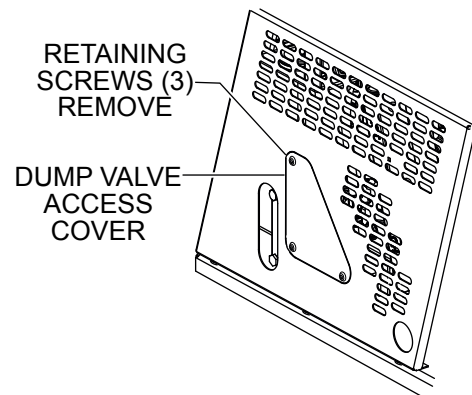
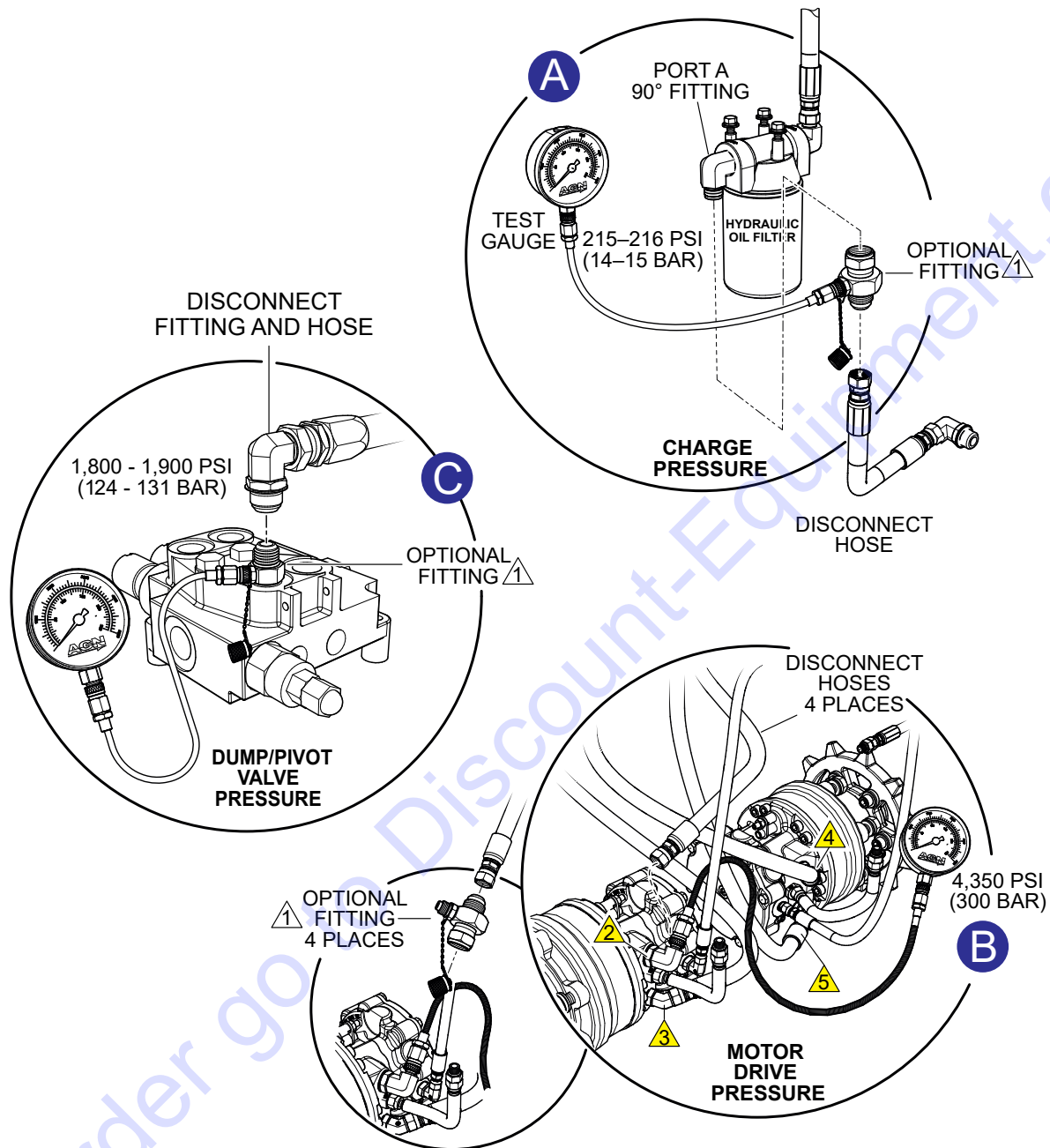

Figure 43. Access Cover

2. Remove the hydraulic hose connected to the 90° fitting from port A on the dump/pivot valve (Figure 44C).
3. Insert the T-fitting and gauge into the 90° fitting.
4. Start the engine and place the dump lever in the dump position. The tub should be in the vertical position. The test gauge should read 1,800 - 1900 psi (124 - 131 bar).
5. Stop the engine and reconnect the hydraulic hose back onto the 90° fitting, port A.



**NOTES:**

- <sup>1</sup> INCLUDED WITH SPECIAL TEST GAUGE KIT  
REFERENCE PARTS MANUAL TO ORDER
- <sup>2</sup> TOP 90° FITTING LEFT-SIDE REVERSE (PUMP 1)
- <sup>3</sup> BOTTOM 45° FITTING LEFT-SIDE REVERSE (PUMP 1)
- <sup>4</sup> TOP 45° FITTING RIGHT-SIDE REVERSE (PUMP 2)
- <sup>5</sup> BOTTOM 45° FITTING RIGHT-SIDE REVERSE (PUMP 2)

**Figure 44. Test Port Connections**



## RUBBER TRACK

### Rubber Track Removal/Installation

1. Lift the track buggy *slightly* off the ground.
2. Using a 1-1/8" socket (Figure 45A), loosen the adjustment bolt until there is *sufficient slack* in the rubber track.
3. Remove the track from the adjustment wheel (Figure 45B).
4. Push the track backwards and remove from the rear sprocket, then pull outward (Figure 45C) and remove the rubber track.
5. Contact your Department of Public Works or recycling agency in your area to arrange for proper disposal of the rubber track.
6. To install a new rubber track, align with the front sprocket and adjustment wheel.
7. Once the rubber track has been properly aligned and placed onto the sprocket, tighten the adjustment bolt (Figure 45D) until there is 0.4–0.6 in. (10–15 mm) tension (Figure 45E) between the center track roller and the rubber track.

### NOTICE

For prolonged use and proper care of the rubber tracks, reference the Safety Information section in this manual.

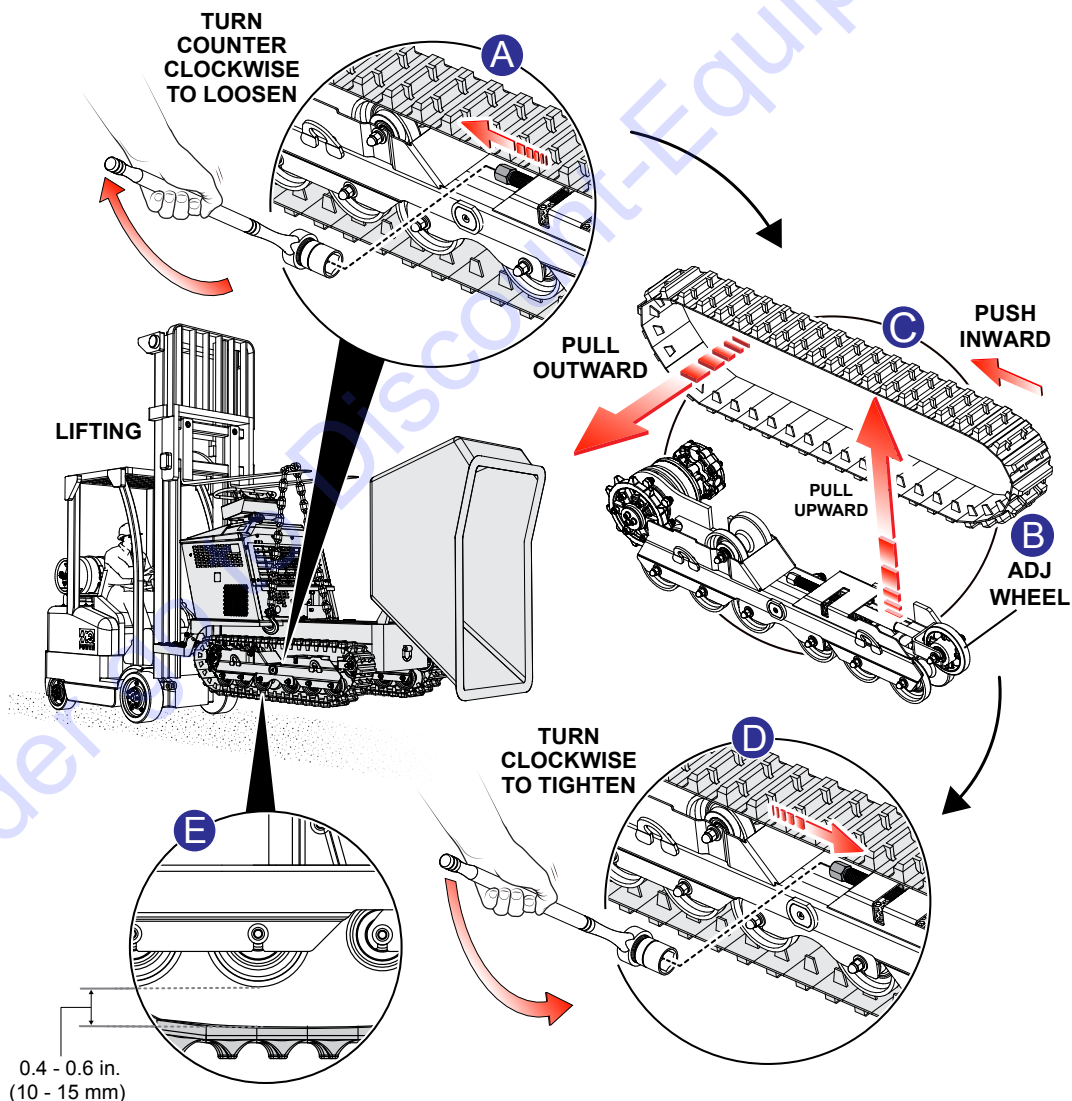

Figure 45. Removing Installing Rubber Track

# LONG-TERM STORAGE/TROUBLESHOOTING (TRACK BUGGY)

## LONG-TERM STORAGE

- Drain the fuel tank completely, or add STA-BIL to the fuel.
- Remove the spark plug and pour a few drops of motor oil into the cylinder. Crank the engine 3–4 times so that oil reaches all internal parts.
- Clean the exterior with a cloth soaked in clean oil.
- Remove the battery.

- Store the unit with a protective cover in a moisture- and dust-free location out of direct sunlight.
- Rotate the rubber track at least once a month to avoid fatigue placed on one point continuously.

### CAUTION

**NEVER** store the power buggy with fuel in the tank for any extended period of time. **ALWAYS** clean up spilled fuel immediately.

Troubleshooting (Track Buggy)		
Symptom	Possible Problem	Solution
Loss of power	Engine rpm too low?	Adjust engine speed.
Loss of travel	Rubber track damaged or loose skipping sprocket teeth?	Inspect rubber track if necessary adjust tension or replace.
	Parking brake engaged (ON)?	Place parking brake knob in OFF position.
	System jerky when levers are activated?	Air in hydraulic system.
	Clogged hydraulic oil filter?	Replace the filter cartridge.
Loss of travel speed	Travel activation control levers out of adjustment?	Inspect levers for full pump stroke.
Machine drifts either to the left or right	Mechanical travel levers out of adjustment?	Adjust levers to neutral position.
Difficult to steer or sluggish movement	Defective or worn rubber tracks?	Inspect rubber track if necessary adjust tension or replace.
Machine does not move or only in one direction	Damaged hydraulic pump or motor?	Inspect for proper hydraulic pressure 4300 psi (300 bar).
	Rubber track is damaged or loose?	Inspect rubber track if necessary adjust tension or replace.
	Broken or damaged travel lever linkage?	Inspect connector ball joints and linkage.
	A foreign object is wedged between track and frame?	Remove object or debris.
System operating hot	Hydraulic oil level is low?	Check hydraulic oil level add oil if necessary
	Defective heat exchanger?	Check 15 amp fuse or replace heat exchanger.
Slow dumping or rotation	Low engine speed?	Check engine speed adjust if necessary
	Dump cylinder may be internally bypassing oil?	Inspect for pressure leakage.
	Dump/rotation valve low pressure?	Check dump valve relief pressure 1800-1900 psi (124-131 bar).
Parking brake will not hold	Defective parking brake solenoid?	Check 5 amp fuse or replace solenoid.
Engine will not start	Low on fuel or empty tank?	Add fuel.
	Defective emergency stop switch?	Check or replace emergency stop switch.
	Fuel shutoff valve is closed?	Open fuel shutoff valve.
	Dead battery?	Verify battery and alternator charge condition.
	Blown Control Box 30 amp fuse?	Check or replace fuse.
	Defective diode?	Check or replace diode.

# TROUBLESHOOTING (ENGINE)

Troubleshooting (Engine)		
Symptom	Possible Problem	Solution
Difficult to start, fuel is available, but no spark at spark plug.	Spark plug bridging?	Check gap, insulation or replace spark plug.
	Carbon deposit on spark plug?	Clean or replace spark plug.
	Short circuit due to deficient spark plug insulation?	Check spark plug insulation, replace if worn.
	Improper spark plug gap?	Set to proper gap.
	Spark plug is red?	Check transistor ignition unit.
	Spark plug is bluish white?	If insufficient compression, repair or replace engine. If injected air leaking, correct leak. If carburetor jets clogged, clean carburetor.
	No spark present at tip of spark plug?	Check if transistor ignition unit is broken, and replace defective unit. Check if voltage cord cracked or broken and replace. Check if spark plug is fouled and replace.
	No oil?	Add oil as required.
	Oil pressure alarm lamp blinks upon starting? (if applicable)	Check automatic shutdown circuit, oil sensor. (if applicable)
Difficult to start, fuel is available, and spark is present at the spark plug.	ON/OFF switch is shorted?	Check switch wiring, replace switch.
	Ignition coil defective?	Replace ignition coil.
	Improper spark gap, points dirty?	Set correct spark gap and clean points.
	Condenser insulation worn or short circuiting?	Replace condenser.
	Spark plug wire broken or short circuiting?	Replace defective spark plug wiring.
Difficult to start, fuel is available, spark is present and compression is normal.	Wrong fuel type?	Flush fuel system, replace with correct type of fuel.
	Water or dust in fuel system?	Flush fuel system.
	Air cleaner dirty?	Clean or replace air cleaner.
	Choke open?	Close choke.
Difficult to start, fuel is available, spark is present and compression is low.	Suction/exhaust valve stuck or protruded?	Reseat valves.
	Piston ring and/or cylinder worn?	Replace piston rings and/or piston.
	Cylinder head and/or spark plug not tightened properly?	Torque cylinder head bolts and spark plug.
No fuel present at carburetor.	Head gasket and/or spark plug gasket damaged?	Replace head and spark plug gaskets.
	No fuel in fuel tank?	Fill with correct type of fuel.
	Fuel cock does not open properly?	Apply lubricant to loosen fuel cock lever, replace if necessary.
	Fuel filter/lines clogged?	Replace fuel filter.
	Fuel tank cap breather hole clogged?	Clean or replace fuel tank cap.
	Air in fuel line?	Bleed fuel line.

## TROUBLESHOOTING (ENGINE)

Troubleshooting (Engine) - continued		
Symptom	Possible Problem	Solution
Weak in power, compression is proper and does not misfire.	Air cleaner dirty?	Clean or replace air cleaner.
	Improper level in carburetor?	Check float adjustment, rebuild carburetor.
	Defective spark plug?	Clean or replace spark plug.
	Improper spark plug?	Set to proper gap.
Weak in power, compression is proper but misfires.	Water in fuel system?	Flush fuel system and replace with correct type of fuel.
	Dirty spark plug?	Clean or replace spark plug.
	Ignition coil defective?	Replace ignition coil.
Engine overheats.	Wrong type of fuel?	Replace with correct type of fuel.
	Cooling fins dirty?	Clean cooling fins.
	Intake air restricted?	Clear intake of dirt and debris. Replace air cleaner elements as necessary.
	Oil level too low or too high?	Adjust oil to proper level.
Rotational speed fluctuates.	Governor adjusted incorrectly?	Adjust governor.
	Governor spring defective?	Replace governor spring.
	Fuel flow restricted?	Check entire fuel system for leaks or clogs.
Recoil starter malfunctions. (if applicable)	Recoil mechanism clogged with dust and dirt?	Clean recoil assembly with soap and water.
	Spiral spring loose?	Replace spiral spring.
Starter malfunctions.	Loose, damaged wiring?	Ensure tight, clean connections on battery and starter.
	Battery insufficiently charged?	Recharge or replace battery.
	Starter damaged or internally shorted?	Replace starter.
Burns too much fuel.	Over-accumulation of exhaust products?	Check and clean valves. Check muffler and replace if necessary.
	Wrong spark plug?	Replace spark plug with manufacturer's suggested type.
Exhaust color is continuously white.	Lubricating oil is wrong viscosity?	Replace lubricating oil with correct viscosity.
	Worn rings?	Replace rings.
Exhaust color is continuously black.	Air cleaner clogged?	Clean or replace air cleaner.
	Choke valve set to incorrect position?	Adjust choke valve to correct position.
	Carburetor defective, seal on carburetor broken?	Replace carburetor or seal.
	Poor carburetor adjustment, engine runs too rich?	Adjust carburetor.
Will not start, no power with key ON. (if applicable)	ON/OFF device not activated ON?	Turn on ON/OFF device.
	Battery disconnected or discharged?	Check cable connections. Charge or replace battery.
	Ignition switch/wiring defective?	Replace ignition switch. Check wiring.

# HYDRAULIC SYSTEM DIAGRAM

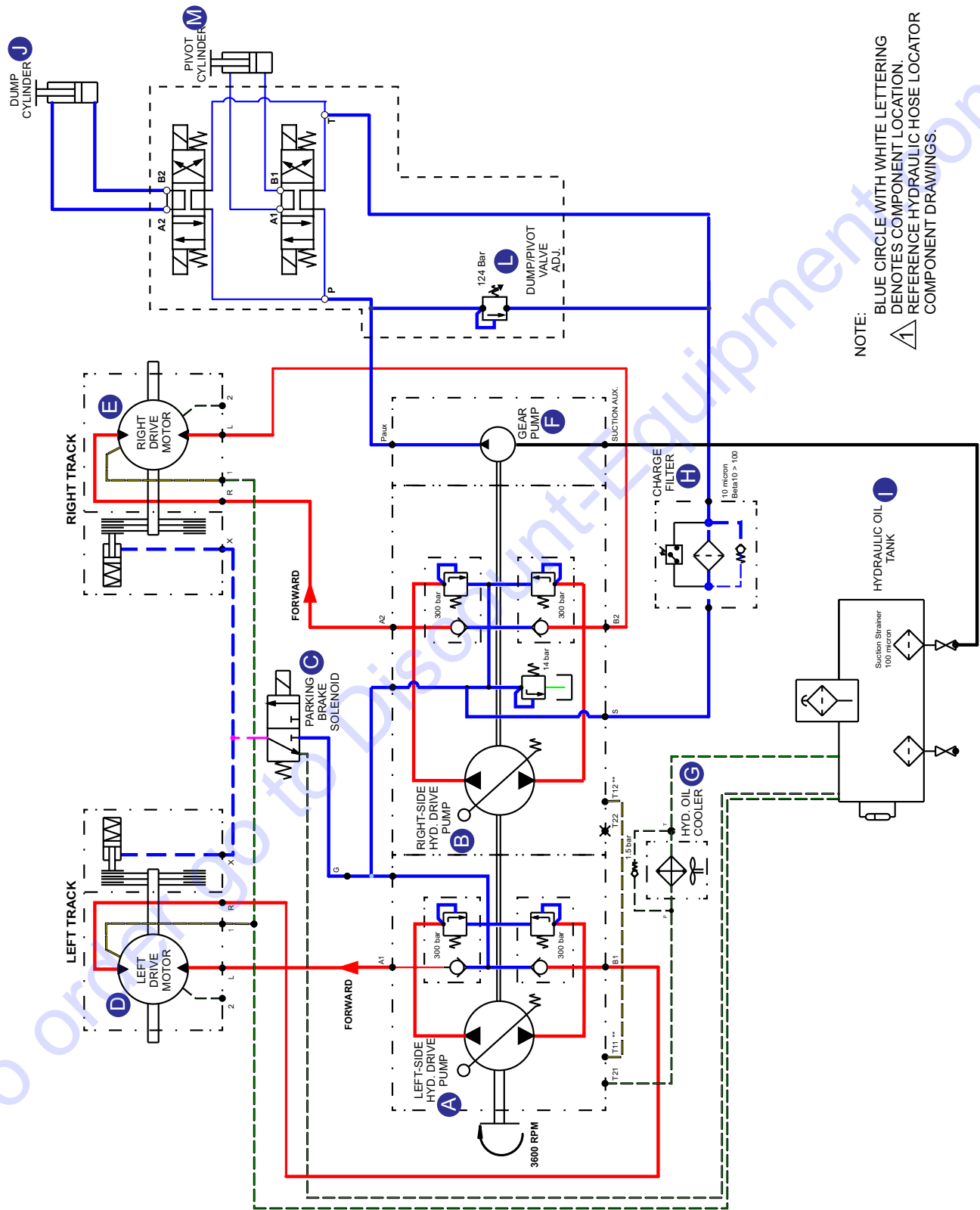

# HYDRAULIC HOSE CONNECTIONS 1

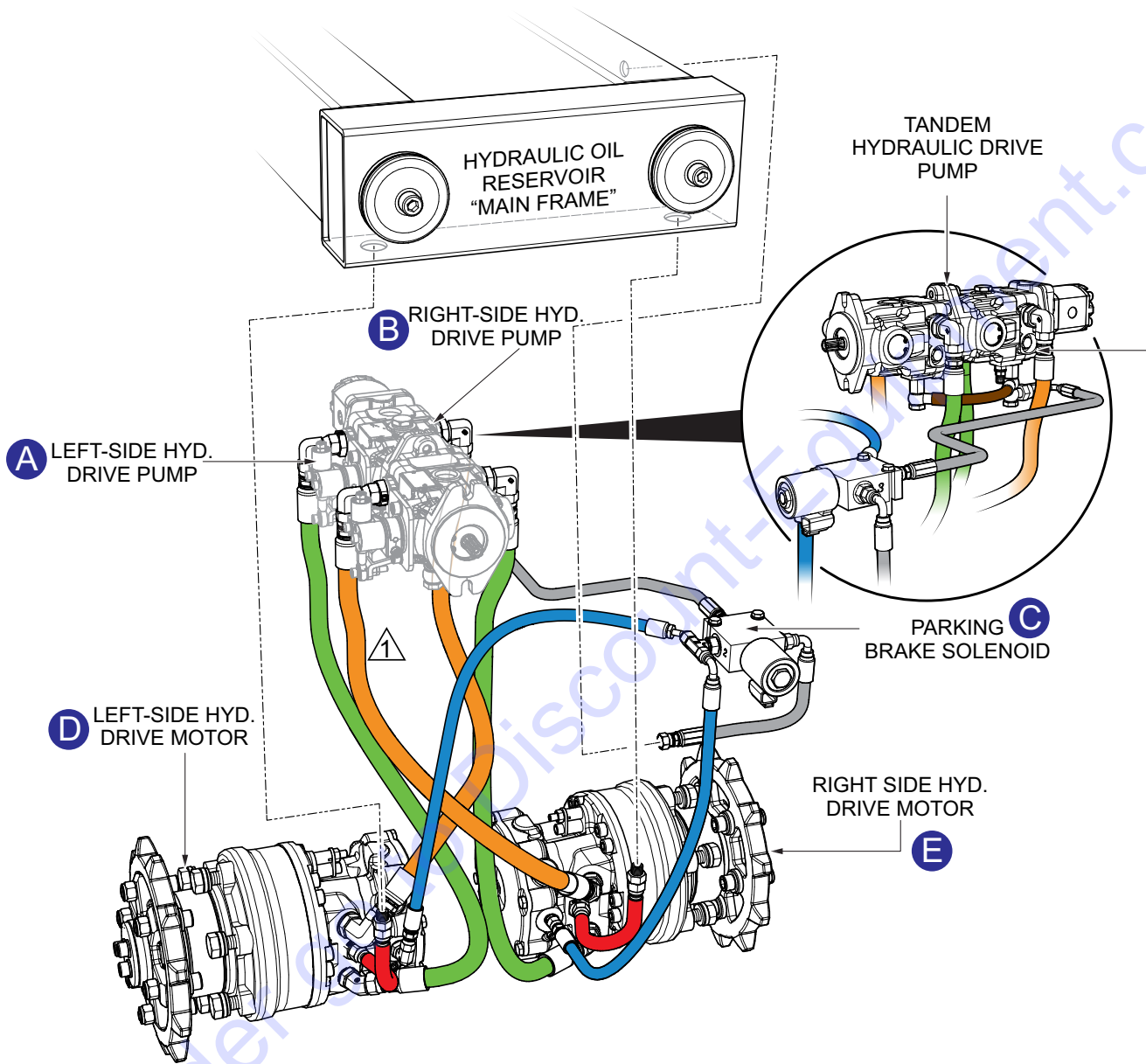

NOTE:

 HOSE COLORS SHOWN FOR CLARITY ONLY.

# HYDRAULIC HOSE CONNECTIONS 2

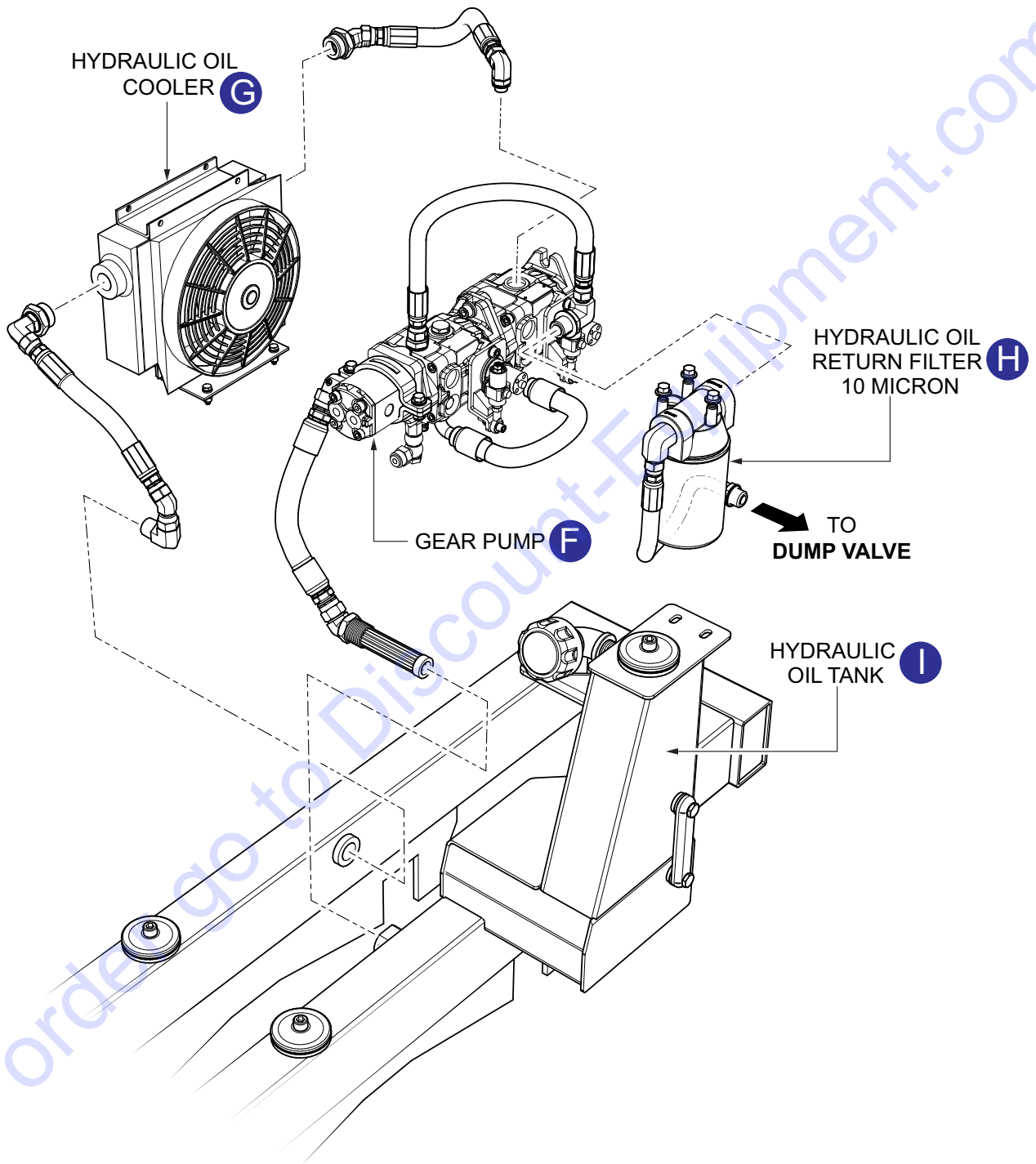

# HYDRAULIC HOSE CONNECTIONS 3

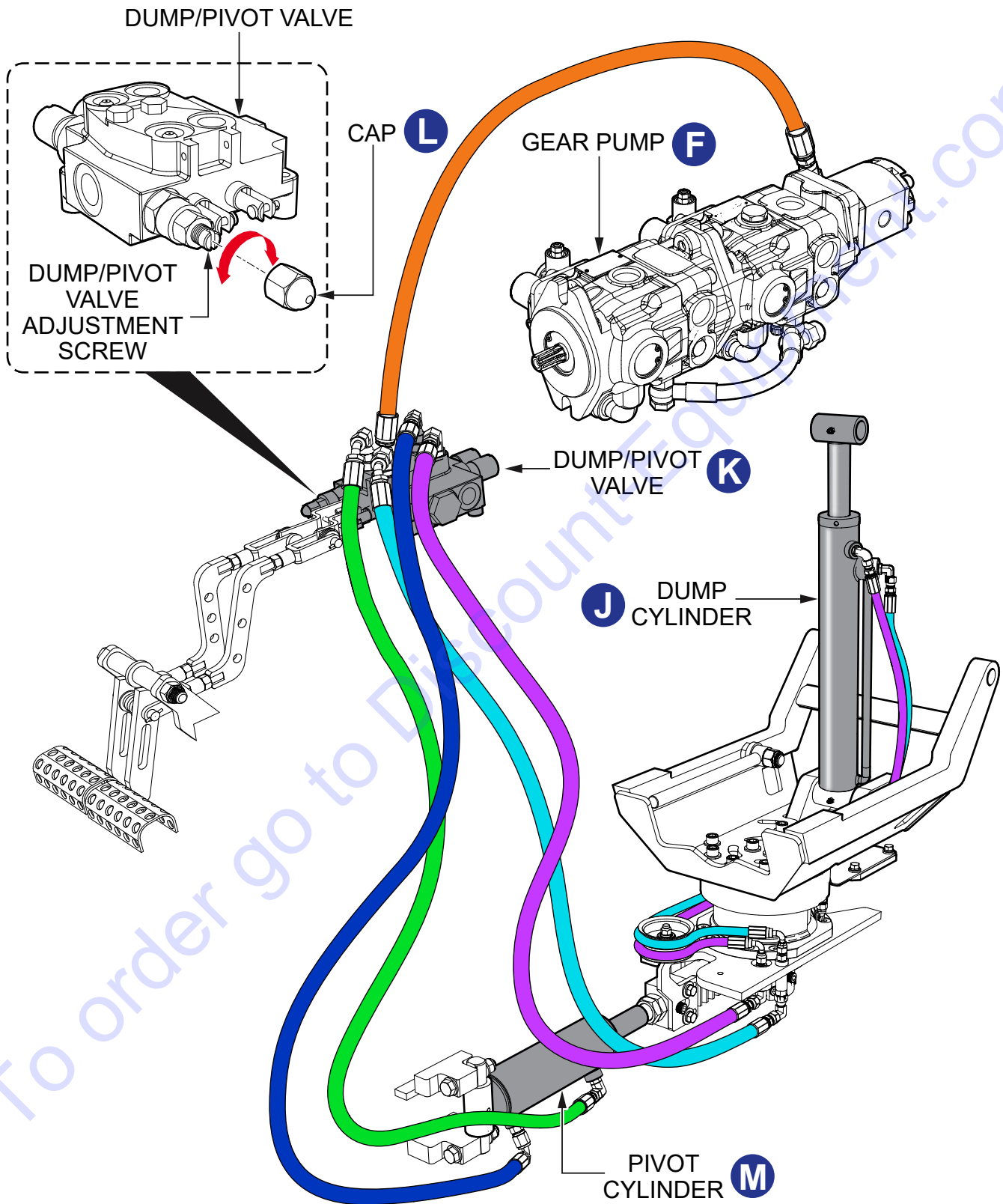



# ELECTRICAL COMPONENT LOCATOR DIAGRAM

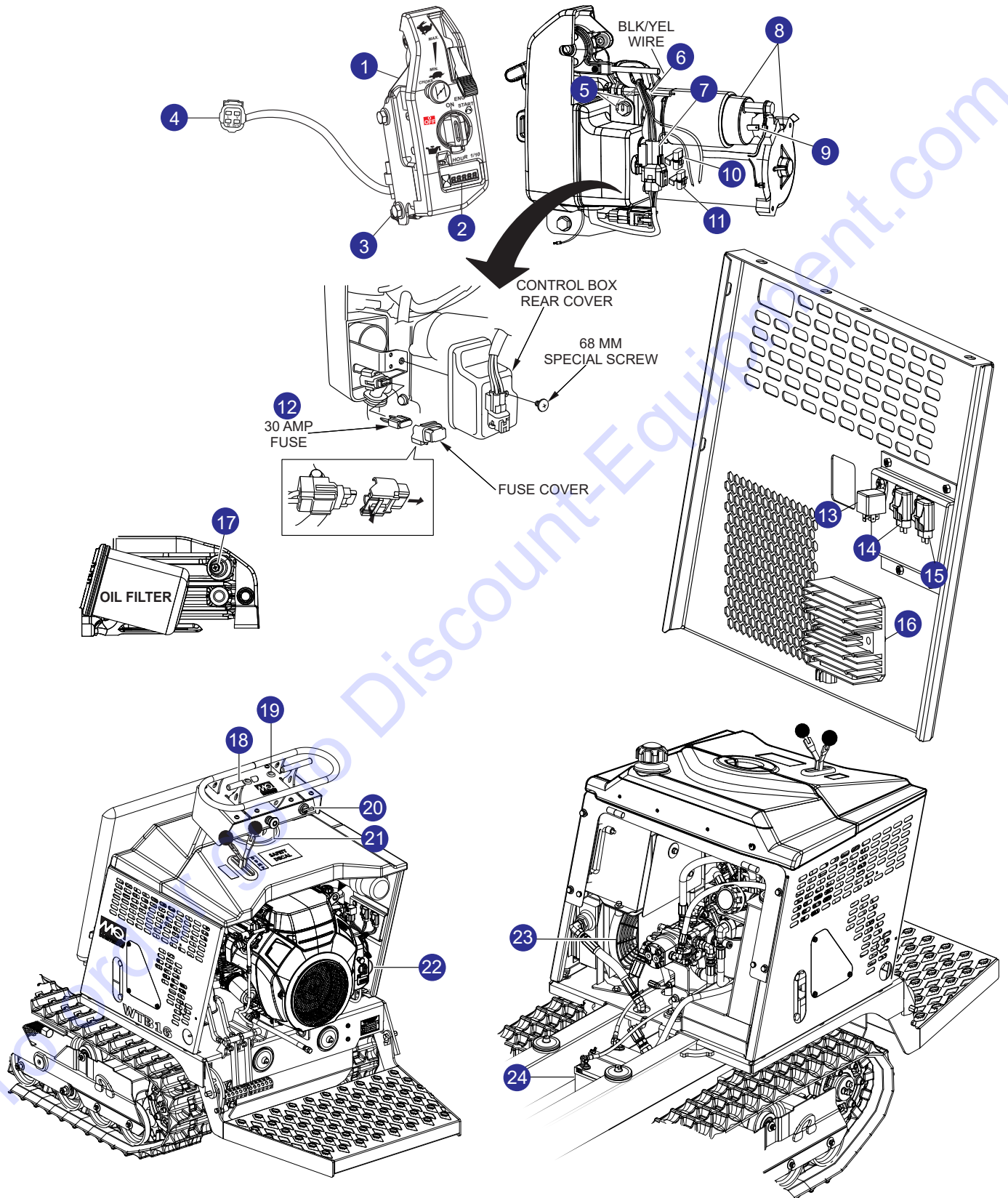

# ELECTRICAL WIRING DIAGRAM

COMBINATION SWITCH		CONTINUITY				
		IG	GND	BAT	LO	ST
OFF						
ON		○	○	○	○	
ST		○		○	○	

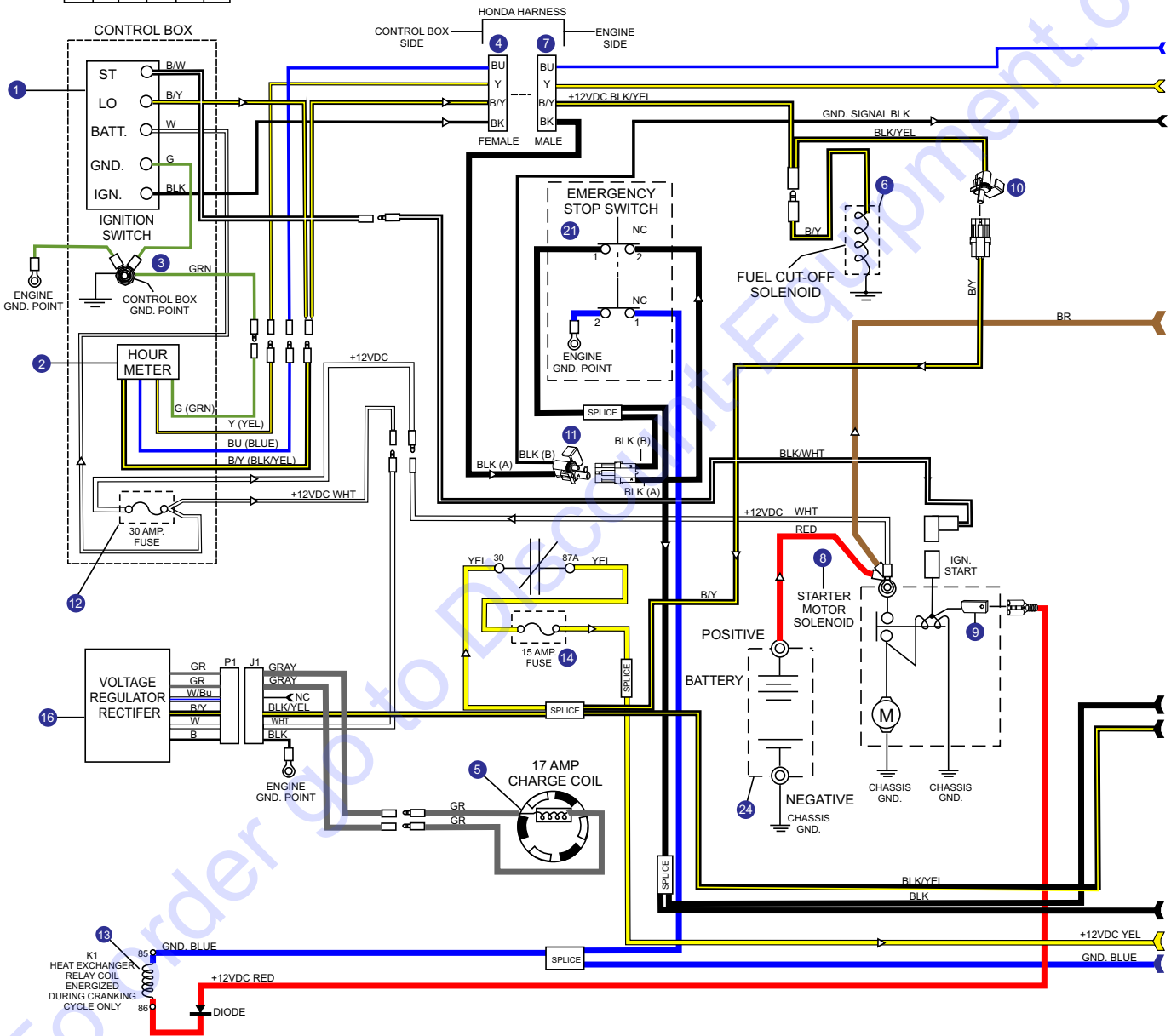

# ELECTRICAL WIRING DIAGRAM

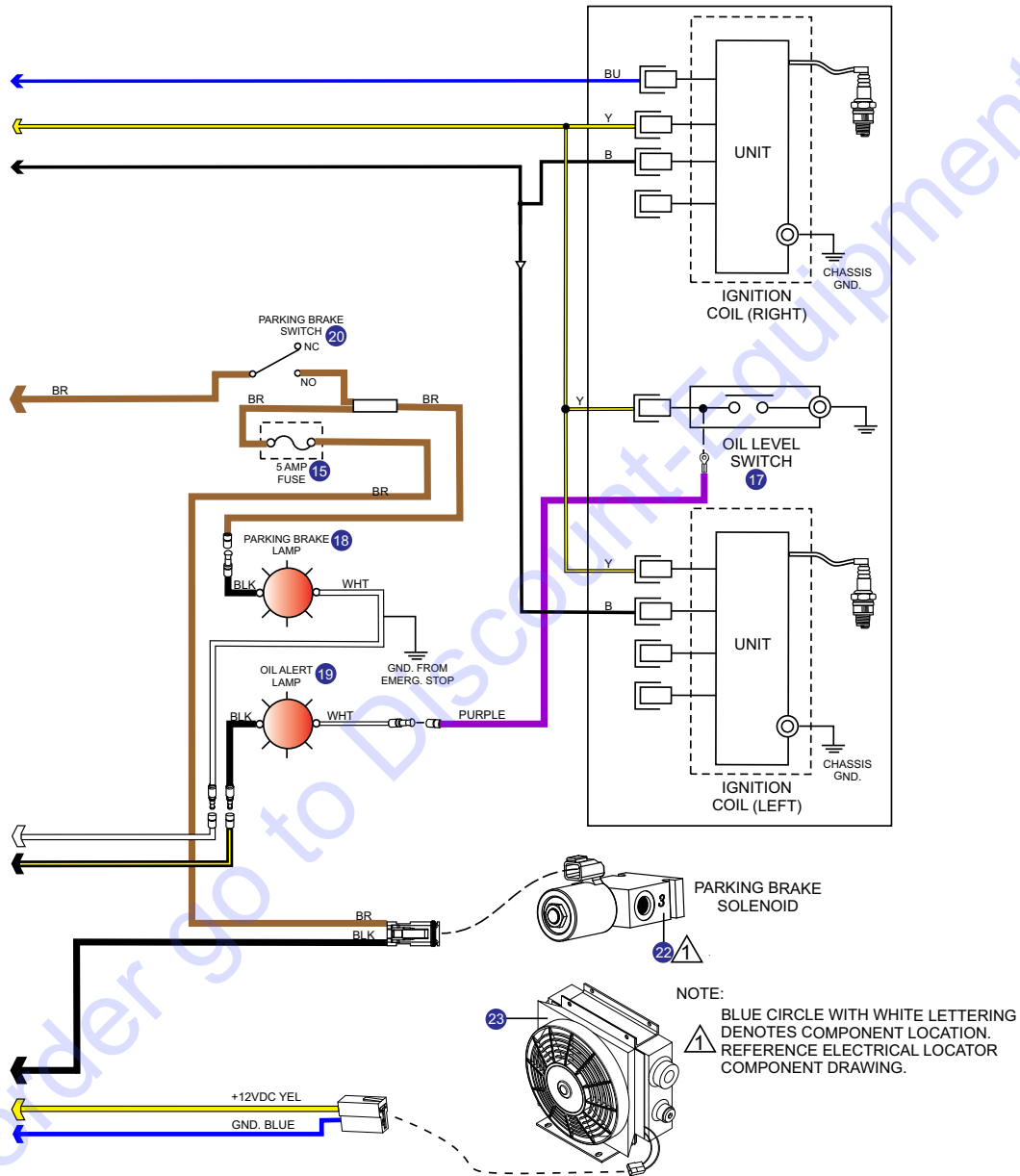

**TO PURCHASE THIS PRODUCT PLEASE CONTACT US**



**Equipment Financing and  
Extended Warranties Available**



**Discount-Equipment.com is your online resource for  
commercial and industrial quality parts and equipment sales.**

**561-964-4949**

**visit us on line @ [www.discount-equipment.com](http://www.discount-equipment.com)**

Select an option below to find your Equipment

**Search by Manufacturer**

**Search by Product Type**

**Request a Quote**

We sell worldwide for the brands: Genie, Terex, JLG, MultiQuip, Mikasa, Essick, Whiteman, Mayco, Toro Stone, Diamond Products, Generac Magnum, Airman, Haulotte, Barreto, Power Blanket, Nifty Lift, Atlas Copco, Chicago Pneumatic, Allmand, Miller Curber, Skyjack, Lull, Skytrak, Tsurumi, Husquvarna Target, Stow, Wacker, Sakai, Mi-T-M, Sullair, Basic, Dynapac, MBW, Weber, Bartell, Bennar Newman, Haulotte, Ditch Runner, Menegotti, Morrison, Contec, Buddy, Crown, Edco, Wyco, Bomag, Laymor, EZ Trench, Bil-Jax, F.S. Curtis, Gehl Pavers, Heli, Honda, ICS/PowerGrit, IHI, Partner, Imer, Clipper, MMD, Koshin, Rice, CH&E, General Equipment, Amida, Coleman, NAC, Gradall, Square Shooter, Kent, Stanley, Tamco, Toku, Hatz, Kohler, Robin, Wisconsin, Northrock, Oztec, Toker TK, Rol-Air, APT, Wylie, Ingersoll Rand / Doosan, Innovatech, Con X, Ammann, Mecalac, Makinex, Smith Surface Prep, Small Line, Wanco, Yanmar