



## DA7000SSA3 Generator

### WhisperWatt™

Prime Rating — 6 kW (6 kVA)

Standby Rating — 7 kW (7 kVA)

Single-Phase, 60 Hertz, 1.0 PF

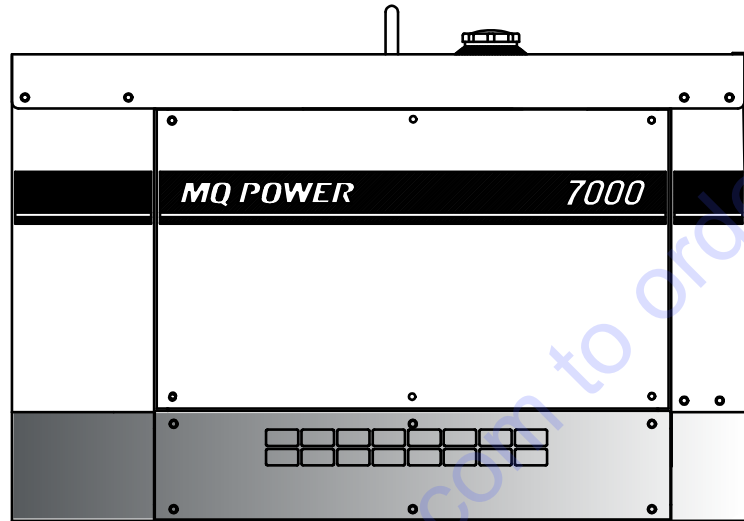

#### STANDARD FEATURES

- Heavy duty, 4-cycle, liquid-cooled diesel engine provides maximum reliability.
- EPA emissions certified — Tier 4 Final emissions compliant.
- Single-side Maintenance Design — Quick, direct access to all filters. External fluid drain extensions allow fast, easy service. Ideal for Ground Heater applications and confined areas.
- Automatic safety shutdown system — Monitors low oil pressure, high water temperature and battery charge via warning lamp display module.
- Excellent voltage regulation — Power is controlled within  $\pm 2.5\%$  of mean voltage. Self-regulated.
- Full load acceptance of standby nameplate rating in a single step.
- Sound attenuated, weather resistant, steel housing provides operation at 65 dB(A) at 23 feet. Fully lockable enclosure allows safe unattended operation.
- E-coat primer with polyurethane enamel finish coat.
- Internal fuel tank — Holds 6.6 gallons (25 liters).
- Brushless Generator Design — Reduces services and maintenance requirements.
- Complete power panel — Fully covered single phase receptacles allow fast and convenient hookup for most applications including temporary power boxes, tools and lighting equipment. All are NEMA standard.
- Complete generator instrumentation — Includes 2-pole GFCI circuit breaker, AC voltmeter, hour meter, idle control switch, full power switch, warning lamp display, and ignition switch.
- Main Line Circuit Breaker — Provides full panel GFCI protection, OSHA and NEC compliant, 25 Amp rating.

# PARTS FINDER

**Search Website  
by Part Number**



**Search Manual  
Library For Parts  
Manual & Lookup Part  
Numbers – Purchase  
or Request Quote**

**Search Manuals**

Enter your information to help us find the right parts manual for your machine.

\* Brand:

\* Model:

\* Serial:

\* Part Number:

SEARCH

**Can't Find Part or  
Manual? Request Help  
by Manufacturer,  
Model & Description**

**Parts Order Form**

Please fill in the following information to help us find the right part for your machine.

Manufacturer:	<input type="text"/>
Model:	<input type="text"/>
Description:	<input type="text"/>
Part Number:	<input type="text"/>
Quantity:	<input type="text"/>
Notes:	<input type="text"/>

Submit

Discount-Equipment.com is your online resource for quality parts & equipment.

Florida: **561-964-4949** Outside Florida TOLL FREE: **877-690-3101**

**Need parts?**

Click on this link: <http://www.discount-equipment.com/category/5443-parts/> and choose one of the options to help get the right parts and equipment you are looking for. Please have the machine model and serial number available in order to help us get you the correct parts. If you don't find the part on the website or on one of the online manuals, please fill out the request form and one of our experienced staff members will get back to you with a quote for the right part that your machine needs.

We sell worldwide for the brands: Genie, Terex, JLG, MultiQuip, Mikasa, Essick, Whiteman, Mayco, Toro Stone, Diamond Products, Generac Magnum, Airman, Haulotte, Barreto, Power Blanket, Nifty Lift, Atlas Copco, Chicago Pneumatic, Allmand, Miller Curber, Skyjack, Lull, Skytrak, Tsurumi, Husquvarna Target, Stow, Wacker, Sakai, Mi-T-M, Sullair, Basic, Dynapac, MBW, Weber, Bartell, Bennar Newman, Haulotte, Ditch Runner, Menegotti, Morrison, Contec, Buddy, Crown, Edco, Wyco, Bomag, Laymor, EZ Trench, Bil-Jax, F.S. Curtis, Gehl Pavers, Heli, Honda, ICS/PowerGrit, IHI, Partner, Imer, Clipper, MMD, Koshin, Rice, CH&E, General Equipment, Amida, Coleman, NAC, Gradall, Square Shooter, Kent, Stanley, Tamco, Toku, Hatz, Kohler, Robin, Wisconsin, Northrock, Oztec, Toker TK, Rol-Air, APT, Wylie, Ingersoll Rand / Doosan, Innovatech, Con X, Ammann, Mecalac, Makinex, Smith Surface Prep, Small Line, Wanco, Yanmar



# DA7000SSA3

## Generator

### SPECIFICATIONS

Generator Specifications	
Design	Revolving field, self-ventilated drip-proof, single bearing
Armature Connection	Series
Excitation	Solid State, Statically Excited System
Phase	Single Phase (3-wire)
Standby Output	7 KW (7 KVA)
Prime Output	6 KW (6 KVA)
Rated Voltage	120/240V
Power Factor	1.0
Voltage Regulation (No load to full load)	±2.5%
Generator RPM	3600
Frequency	60 Hz
Winding Pitch	11/16
No. of Poles	2
No. of Leads	4
Frequency Regulation: No Load to Full Load	3-5% under varying loads from no load to 100% rated load
Frequency Regulation: Steady State	±2.5% of mean value for constant loads from no load to full load
Insulation	Class F
Sound Level dB(A) Full load at 23 feet	65

Amperage	
Rated Voltage	Amps
120 Volt	58.3 Max
120 Volt	50 Continuous
240 Volt	29.2 Max
240 Volt	25 Continuous

Engine Specifications	
Make / Model	Kubota / Z482-E3B
Emissions	EPA Tier 4 Final Certified
Starting System	Electric
Design	Vertical, 4-cycle, liquid cooled, diesel engine
Displacement	29.23 in <sup>3</sup> (479 cc)
No. cylinders	2
Bore x Stroke	2.52 x 2.68 in. (64 x 68 mm)
Gross Engine Power Output	12.5 hp (9.3 kW)
Compression Ratio	23:1
Engine Speed	3600 rpm
Oil Capacity	.66 gallons (2.5 liters)
Coolant Capacity	.74 gallons (2.8 liters)
Starting System	Electric
Battery	12V 35Ah x 1

Fuel System		
Recommended Fuel	ASTM-D975-No.1 & No.2-D*	
Fuel Tank Capacity	6.6 gallons (25 liters)	
<b>Fuel Consumption</b>	<b>gph</b>	<b>lph</b>
At full load	0.69	2.6
At 3/4 load	0.55	2.1
At 1/2 load	0.48	1.8
At 1/4 load	0.37	1.4

\* - Use ultra-low sulfur diesel fuel.

**NOTICE**  
 Specifications sheet is subject to change and is not intended for use in installation design.



# DA7000SSA3

## Generator

### MQ POWER DECIBEL LEVELS



Our soundproof housing allows substantially lower operating noise levels than competitive design. WhisperWatts™ are at home on construction sites, in residential neighborhoods, and at hospitals — just about anywhere.

- 90 — Subway / truck traffic
- 80 — Average city traffic
- 70 — Inside car at 60 mph  
— WhisperWatt™ at 23 feet
- 60 — Air conditioner at 20 feet
- 50 — Normal conversation



### GENERATOR OUTPUT PANEL

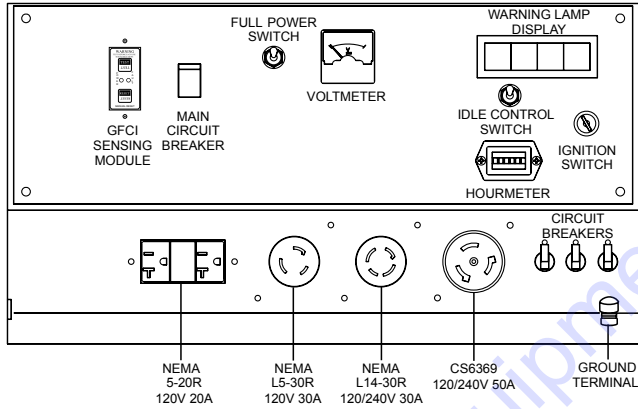

### OPTIONAL GENERATOR FEATURES

- **Automatic Start/Stop Control** — Automatically starts and monitors generator during power failure when used in conjunction with a transfer switch.
- **Jacket Water Heater** — For easy starting in cold climates.
- **Solid State Battery Charger** — Provides fully automatic and self-adjusting charging to the generator's battery system.
- **Fuel/Water Separator** — Effectively separates damaging condensation from fuel.
- **Emergency Stop Switch** — When manually activated, shuts down generator in the event of an emergency.
- **Trailer Mounted Package** — Highway legal trailer with electric brakes with single axle configuration. Extra capacity fuel tank is also available.

### OPTIONAL FUEL CELL FEATURES

- **Sub-base Cells (Single Wall or Double Wall)** — Additional fuel cell for extended run time. Available in a variety of configurations.



# DA7000SSA3

## Generator

### SKID-MOUNT DIMENSIONS

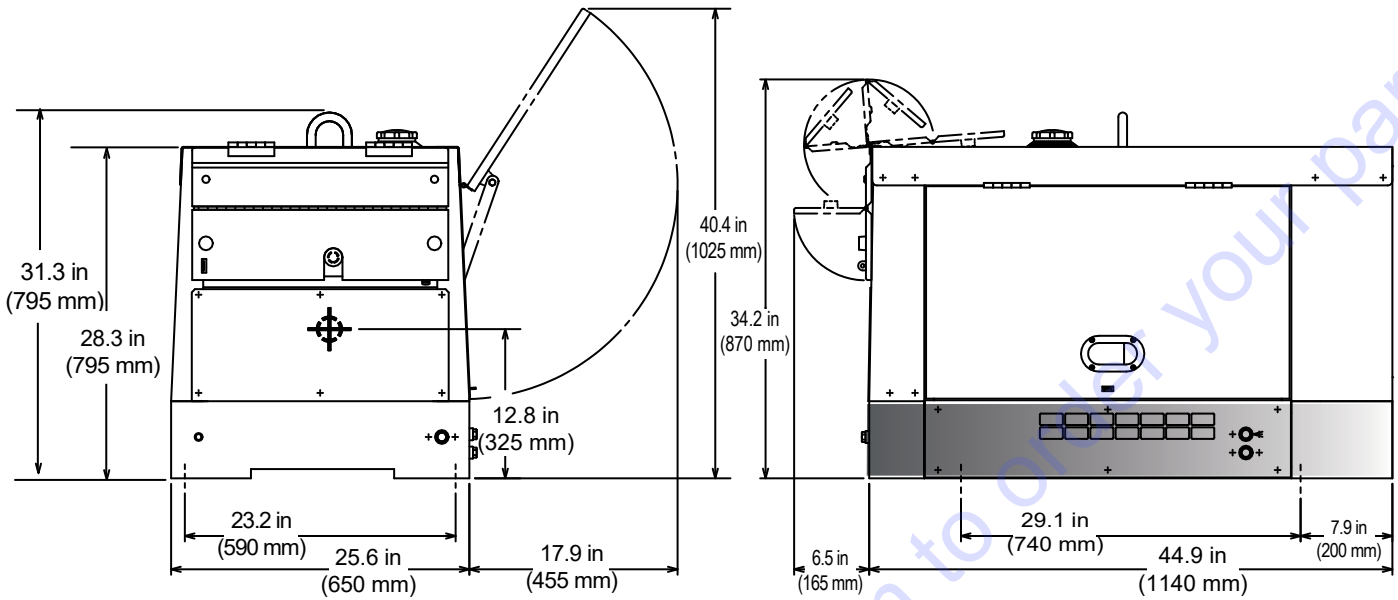

### TRAILER-MOUNT DIMENSIONS

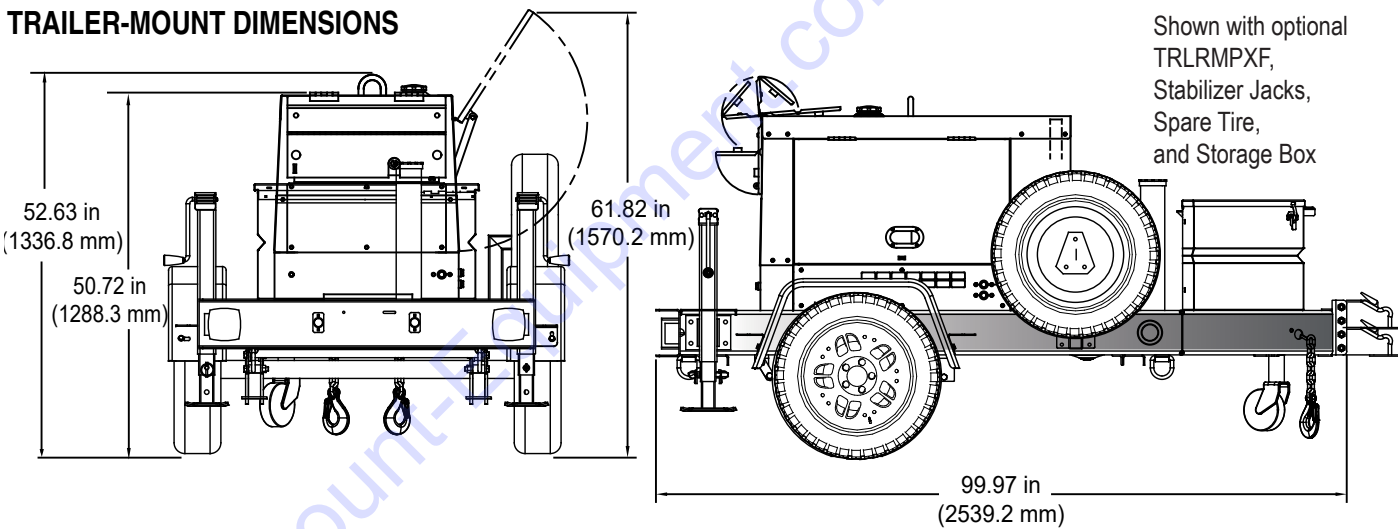

#### DA7000SSA3 Weights\*

Dry Weight	533 lbs. (242 kg)
Wet Weight	597 lbs. (271 kg)
Max. Lifting Point Capacity	2,910 lbs. (1,320 kg)

\* Weights do not include options.

#### DA7000SSA3 and TRLRMPXF Weights\*

Dry Weight (with TRLRMPXF)	1,041 lbs. (472 kg)
Wet Weight (with TRLRMPXF)	1,105 lbs. (501 kg)

#### NOTICE

Features and Specifications are subject to change without notice.

# PARTS FINDER

**Search Website  
by Part Number**



**Search Manual  
Library For Parts  
Manual & Lookup Part  
Numbers – Purchase  
or Request Quote**

**Search Manuals**

Enter your information to help us find the right parts manual for your machine.

\* Brand:

\* Model:

\* Serial:

\* Part Number:

SEARCH

**Can't Find Part or  
Manual? Request Help  
by Manufacturer,  
Model & Description**

**Parts Order Form**

Please fill in the following information to help us find the right part for your machine.

Manufacturer:	<input type="text"/>
Model:	<input type="text"/>
Description:	<input type="text"/>
Part Number:	<input type="text"/>
Quantity:	<input type="text"/>
Notes:	<input type="text"/>

Submit

Discount-Equipment.com is your online resource for quality parts & equipment.

Florida: **561-964-4949** Outside Florida TOLL FREE: **877-690-3101**

**Need parts?**

Click on this link: <http://www.discount-equipment.com/category/5443-parts/> and choose one of the options to help get the right parts and equipment you are looking for. Please have the machine model and serial number available in order to help us get you the correct parts. If you don't find the part on the website or on one of the online manuals, please fill out the request form and one of our experienced staff members will get back to you with a quote for the right part that your machine needs.

We sell worldwide for the brands: Genie, Terex, JLG, MultiQuip, Mikasa, Essick, Whiteman, Mayco, Toro Stone, Diamond Products, Generac Magnum, Airman, Haulotte, Barreto, Power Blanket, Nifty Lift, Atlas Copco, Chicago Pneumatic, Allmand, Miller Curber, Skyjack, Lull, Skytrak, Tsurumi, Husquvarna Target, Stow, Wacker, Sakai, Mi-T-M, Sullair, Basic, Dynapac, MBW, Weber, Bartell, Bennar Newman, Haulotte, Ditch Runner, Menegotti, Morrison, Contec, Buddy, Crown, Edco, Wyco, Bomag, Laymor, EZ Trench, Bil-Jax, F.S. Curtis, Gehl Pavers, Heli, Honda, ICS/PowerGrit, IHI, Partner, Imer, Clipper, MMD, Koshin, Rice, CH&E, General Equipment, Amida, Coleman, NAC, Gradall, Square Shooter, Kent, Stanley, Tamco, Toku, Hatz, Kohler, Robin, Wisconsin, Northrock, Oztec, Toker TK, Rol-Air, APT, Wylie, Ingersoll Rand / Doosan, Innovatech, Con X, Ammann, Mecalac, Makinex, Smith Surface Prep, Small Line, Wanco, Yanmar