



Service Bulletin
HHNG5 Mechanical Ride-On Trowels
Charcoal Canister Bracket Replacement

Product Group: Ride-On Trowels	Date Issued: 08/02/16	Service Bulletin No. TR20160720
Bulletin Type <input checked="" type="checkbox"/> Mandatory <input type="checkbox"/> Information Only <input type="checkbox"/> Recommended Change		Models/Series Affected: HHNG5 S/N PD0209362 — PD0209401 S/N PE0209411 — PE0209438 S/N PF0209459 — PF0209489

Details Problems: a. Fuel from the fuel tank vent hose can spill onto the charcoal canister causing fuel saturation of the canister. Solutions: a. Replace existing charcoal canister bracket with new designed bracket. The new bracket allows the canister to be mounted in a position higher than the vent hose.
--

Parts Information										
<table border="1"> <thead> <tr> <th>Item No.</th> <th>Part No.</th> <th>Description</th> <th>QTY.</th> <th>Remarks</th> </tr> </thead> <tbody> <tr> <td>1</td> <td>32679</td> <td>Bracket, Charcoal Canister</td> <td>1</td> <td></td> </tr> </tbody> </table>	Item No.	Part No.	Description	QTY.	Remarks	1	32679	Bracket, Charcoal Canister	1	
Item No.	Part No.	Description	QTY.	Remarks						
1	32679	Bracket, Charcoal Canister	1							

WORK SAFELY!

Only a **qualified service technician** with proper training should perform this installation. Follow all shop safety rules when performing this installation.

REQUIRED TOOLS

- Ratchet and Socket Set
- Flat Blade Screwdriver

CHARCOAL CANISTER REMOVAL

1. Place the fuel valve lever (Figure 1) in the **CLOSED** position.

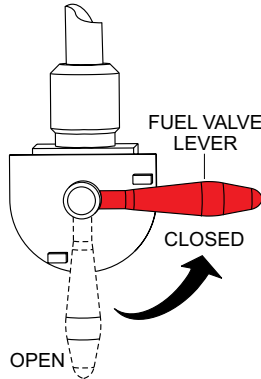

Figure 1. Fuel Valve Lever (Closed)

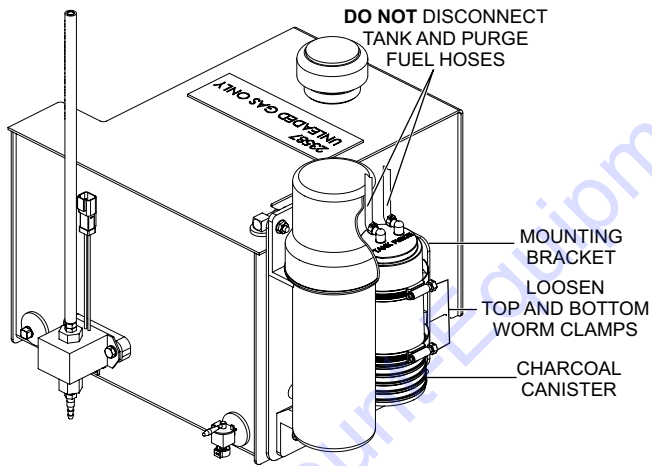

Figure 2. Charcoal Canister Removal

2. Remove the two large worm clamps that secure the canister to the mounting bracket. **DO NOT** discard worm clamps, they will be mounted onto the new mounting bracket.

NOTICE

DO NOT remove *tank* and *purge* fuel hoses from charcoal canister.

3. Remove canister and set on top of fuel tank.

MANUAL HOLDER REMOVAL

1. Unscrew the cap (Figure 3) from the manual holder. This will allow for easy access to the manual holder retaining nuts.

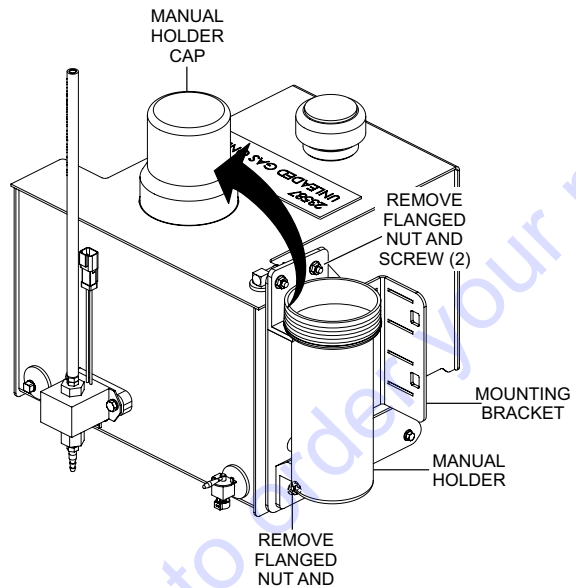

Figure 3. Manual Holder Removal

2. Next, remove the three flanged nuts and screws that secure the manual holder (Figure 3) to the mounting bracket.
3. Remove manual holder from mounting bracket and set aside.

MOUNTING BRACKET REMOVAL

1. Remove the two screws (Figure 4) that secure the mounting bracket to the fuel tank. Screws can be located at bottom of mounting bracket.

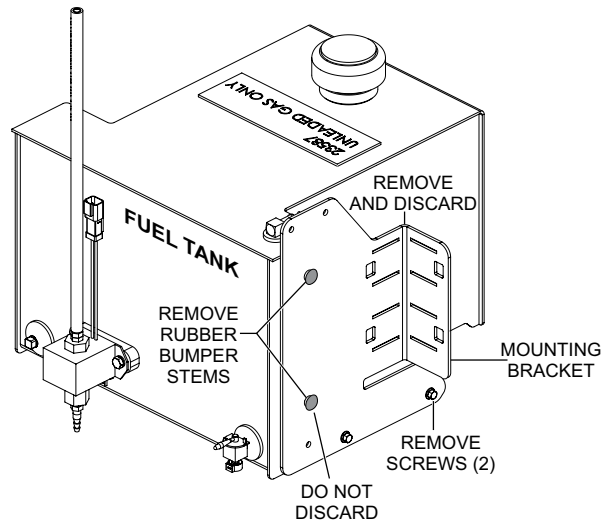

Figure 4. Mounting Bracket Removal

- Remove both existing rubber bumper stems from the mounting bracket. **DO NOT** discard bumper stems, they will be mounted onto the new mounting bracket.
- Discard** mounting bracket.

RUBBER BUMPER STEMS INSTALLATION

- Insert the existing rubber bumper stems (Figure 5) into the hole opening on the **new** mounting bracket (P/N32679).

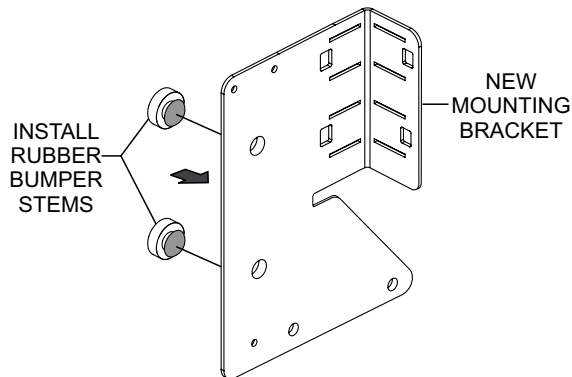

Figure 5. Bumper Stems Installation

MANUAL HOLDER INSTALLATION

- Reinstall manual holder (Figure 6) back onto charcoal canister bracket using the three mounting screws and flanged nuts that were removed earlier (Figure 3).

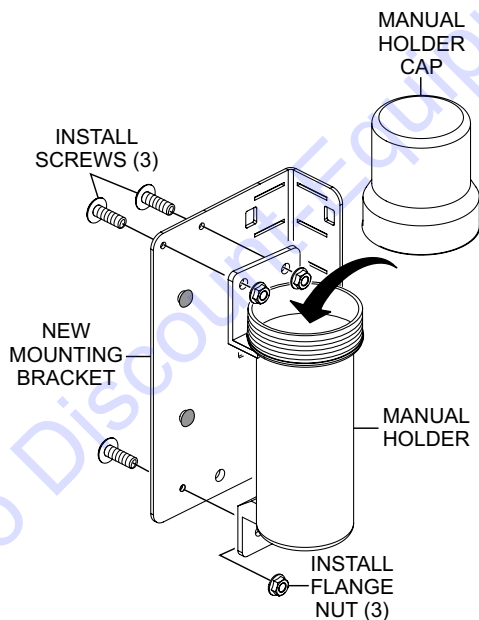

Figure 6. Manual Holder Installation

- Reinstall cap back onto manual holder.

NEW MOUNTING BRACKET/CHARCOAL CANISTER INSTALLATION

- Place new mounting bracket (Figure 7) up against the fuel tank, and secure at bottom of fuel tank using the two mounting screws that were removed earlier (Figure 4).
- Secure charcoal canister (Figure 7) to mounting bracket using the existing large worm clamps. Tighten each clamp securely.

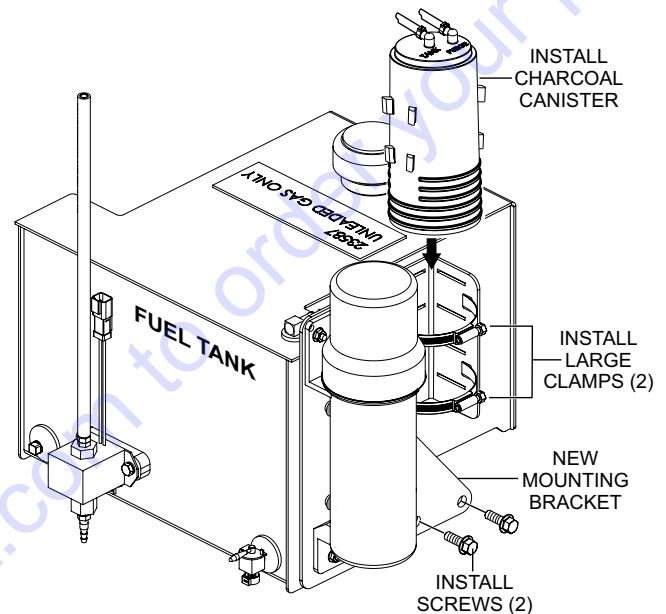

Figure 7. Installing Mounting Bracket/Charcoal Canister

- Place the fuel valve lever (Figure 8) in the **OPEN** position.

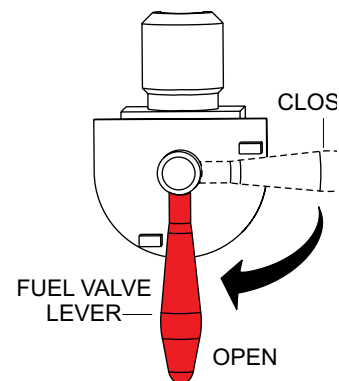

Figure 8. Fuel Valve Lever (Open)

- Start engine and check for fuel leaks.

PARTS FINDER

**Search Website
by Part Number**



**Search Manual
Library For Parts
Manual & Lookup Part
Numbers – Purchase
or Request Quote**

Search Manuals

Enter your information to help us find the right parts manual for your machine.

* Brand:

* Model:

* Serial:

* Part Number:

SEARCH

**Can't Find Part or
Manual? Request Help
by Manufacturer,
Model & Description**

Parts Order Form

Please fill in the following information to help us find the right part for your machine.

Manufacturer:	<input type="text"/>
Model:	<input type="text"/>
Description:	<input type="text"/>
Part Number:	<input type="text"/>
Quantity:	<input type="text"/>
Notes:	<input type="text"/>

Submit

Discount-Equipment.com is your online resource for quality parts & equipment.

Florida: **561-964-4949** Outside Florida TOLL FREE: **877-690-3101**

Need parts?

Click on this link: <http://www.discount-equipment.com/category/5443-parts/> and choose one of the options to help get the right parts and equipment you are looking for. Please have the machine model and serial number available in order to help us get you the correct parts. If you don't find the part on the website or on one of the online manuals, please fill out the request form and one of our experienced staff members will get back to you with a quote for the right part that your machine needs.

We sell worldwide for the brands: Genie, Terex, JLG, MultiQuip, Mikasa, Essick, Whiteman, Mayco, Toro Stone, Diamond Products, Generac Magnum, Airman, Haulotte, Barreto, Power Blanket, Nifty Lift, Atlas Copco, Chicago Pneumatic, Allmand, Miller Curber, Skyjack, Lull, Skytrak, Tsurumi, Husquvarna Target, Stow, Wacker, Sakai, Mi-T-M, Sullair, Basic, Dynapac, MBW, Weber, Bartell, Bennar Newman, Haulotte, Ditch Runner, Menegotti, Morrison, Contec, Buddy, Crown, Edco, Wyco, Bomag, Laymor, EZ Trench, Bil-Jax, F.S. Curtis, Gehl Pavers, Heli, Honda, ICS/PowerGrit, IHI, Partner, Imer, Clipper, MMD, Koshin, Rice, CH&E, General Equipment, Amida, Coleman, NAC, Gradall, Square Shooter, Kent, Stanley, Tamco, Toku, Hatz, Kohler, Robin, Wisconsin, Northrock, Oztec, Toker TK, Rol-Air, APT, Wylie, Ingersoll Rand / Doosan, Innovatech, Con X, Ammann, Mecalac, Makinex, Smith Surface Prep, Small Line, Wanco, Yanmar