

OPERATION AND PARTS MANUAL



GloBug
MODEL GB113BC
LIGHTING SYSTEM
(FOR USE WITH MQ SERIES GENERATORS)

Revision #4 (01/06/09)



PARTS FINDER

**Search Website
by Part Number**



**Search Manual
Library For Parts
Manual & Lookup Part
Numbers – Purchase
or Request Quote**

Search Manuals

Enter your information to help us find the right parts manual for your machine.

* Brand:

* Model:

* Serial:

* Part Number:

SEARCH

**Can't Find Part or
Manual? Request Help
by Manufacturer,
Model & Description**

Parts Order Form

Please fill in the following information to help us find the right part for your machine.

Manufacturer:	<input type="text"/>
Model:	<input type="text"/>
Description:	<input type="text"/>
Part Number:	<input type="text"/>
Quantity:	<input type="text"/>
Notes:	<input type="text"/>

Discount-Equipment.com is your online resource for quality parts & equipment.



Florida: **561-964-4949** Outside Florida TOLL FREE: **877-690-3101**

Need parts?

Click on this link: <http://www.discount-equipment.com/category/5443-parts/> and choose one of the options to help get the right parts and equipment you are looking for. Please have the machine model and serial number available in order to help us get you the correct parts. If you don't find the part on the website or on one of the online manuals, please fill out the request form and one of our experienced staff members will get back to you with a quote for the right part that your machine needs.

We sell worldwide for the brands: Genie, Terex, JLG, MultiQuip, Mikasa, Essick, Whiteman, Mayco, Toro Stone, Diamond Products, Generac Magnum, Airman, Haulotte, Barreto, Power Blanket, Nifty Lift, Atlas Copco, Chicago Pneumatic, Allmand, Miller Curber, Skyjack, Lull, Skytrak, Tsurumi, Husquvarna Target, Stow, Wacker, Sakai, Mi-T-M, Sullair, Basic, Dynapac, MBW, Weber, Bartell, Bennar Newman, Haulotte, Ditch Runner, Menegotti, Morrison, Contec, Buddy, Crown, Edco, Wyco, Bomag, Laymor, EZ Trench, Bil-Jax, F.S. Curtis, Gehl Pavers, Heli, Honda, ICS/PowerGrit, IHI, Partner, Imer, Clipper, MMD, Koshin, Rice, CH&E, General Equipment, Amida, Coleman, NAC, Gradall, Square Shooter, Kent, Stanley, Tamco, Toku, Hatz, Kohler, Robin, Wisconsin, Northrock, Oztec, Toker TK, Rol-Air, APT, Wylie, Ingersoll Rand / Doosan, Innovatech, Con X, Ammann, Mecalac, Makinex, Smith Surface Prep, Small Line, Wanco, Yanmar

PROPOSITION 65 WARNING

**WARNING**

CALIFORNIA — Proposition 65 Warning

Engine exhaust and some of its constituents are known to the State of California to cause cancer, birth defects and other reproductive harm.

Go to Discount-Equipment.com to buy your parts

TABLE OF CONTENTS

MQ GLOBUG LIGHTING SYSTEM

Proposition 65 Warning	2
Table Of Contents	4
Parts Ordering Procedures	5
Safety Information	6-9
Specifications	10
Dimensions	11
Floodlight Footcandle Plots (BAL-120 Oval)	12
Floodlight Footcandle Plots (BAL-120R Ref.)	13
Floodlight Footcandle Plots (BAL-115D Drum)	14
General Information	15
Components	16-17
Setup	18-19
Setup/Operation	20
Shutdown	22
Maintenance	22-31
Troubleshooting (Lamps)	32
Troubleshooting (Mast)	33
Explanation Of Codes In Remarks Column	34
Suggested Spare Parts	35

COMPONENT DRAWINGS

Nameplate and Decals Assembly	36-37
T-Handle Assembly	38-39
Steering Assembly	40-41
Outrigger Assembly	42-43
Mast Adapter Assembly	44-45
Main Mast Assembly	46-47
Winch Assembly	48-49
Mast Section Assembly	50-51
Baseplate Cover Assembly	52-53
Ballast Box Assembly	54-55
Fan Blower/Lamp Base Assembly	56-57
Balloon/Lamp Guard Assembly	58-59
Terms and Conditions Of Sale — Parts	60

NOTICE

Specification and part number are subject to change without notice.

SAFETY INFORMATION

Do not operate or service the equipment before reading the entire manual. Safety precautions should be followed at all times when operating this equipment. Failure to read and understand the safety messages and operating instructions could result in injury to yourself and others.



SAFETY MESSAGES

The four safety messages shown below will inform you about potential hazards that could injure you or others. The safety messages specifically address the level of exposure to the operator and are preceded by one of four words: **DANGER**, **WARNING**, **CAUTION** or **NOTICE**.

SAFETY SYMBOLS

DANGER

Indicates a hazardous situation which, if not avoided, **WILL** result in **DEATH** or **SERIOUS INJURY**.

WARNING

Indicates a hazardous situation which, if not avoided, **COULD** result in **DEATH** or **SERIOUS INJURY**.

CAUTION

Indicates a hazardous situation which, if not avoided, **COULD** result in **MINOR** or **MODERATE INJURY**.

NOTICE

Addresses practices not related to personal injury.

Potential hazards associated with the operation of this equipment will be referenced with hazard symbols which may appear throughout this manual in conjunction with safety messages.

Symbol	Safety Hazard
	Burn hazards
	Electric shock hazards

GENERAL SAFETY

CAUTION

- **NEVER** operate this equipment without proper protective clothing, shatterproof glasses, respiratory protection, hearing protection, steel-toed boots and other protective devices required by the job or city and state regulations.



- **NEVER** operate this equipment when not feeling well due to fatigue, illness or when under medication.
- **NEVER** operate this equipment under the influence of drugs or alcohol.



NOTICE

- This equipment should only be operated by trained and qualified personnel 18 years of age and older.
- Whenever necessary, replace nameplate, operation and safety decals when they become difficult read.
- Manufacturer does not assume responsibility for any accident due to equipment modifications. Unauthorized equipment modification will void all warranties.
- **NEVER** use accessories or attachments that are not recommended by Multiquip for this equipment. Damage to the equipment and/or injury to user may result.
- **ALWAYS** know the location of the nearest **fire extinguisher**.
- **ALWAYS** know the location of the nearest **first aid kit**.
- **ALWAYS** know the location of the nearest phone or **keep a phone on the job site**. Also, know the phone numbers of the nearest **ambulance**, **doctor** and **fire department**. This information will be invaluable in the case of an emergency.



SAFETY INFORMATION

LIGHTING SYSTEM SAFETY

DANGER

- **NEVER** use lighting system in **rain, snow** or areas of high humidity that could generate electrical storms.



WARNING

- **NEVER** disconnect any **emergency or safety devices**. These devices are intended for operator safety. Disconnection of these devices can cause **severe injury, bodily harm or even death**. Disconnection of any of these devices will void all warranties.

CAUTION

- **NEVER** attempt service on a running machine.

NOTICE

- To prevent the lighting system from overturning, **NEVER** use in winds that exceed 22mph (10 m/s).
- The lighting system should only be used in temperatures between 23° to 104°F (-5° to 40° C). Failure to comply with these operating parameters could cause the lamp to malfunction and shorten the ballast life.
- **ALWAYS** keep the lighting system in proper running condition.
- Fix damage to lighting system and replace any broken parts immediately.
- **ALWAYS** store equipment properly when it is not being used. Equipment should be stored in a clean, dry location out of the reach of children and unauthorized personnel.

LAMP SAFETY

WARNING

- **NEVER** attempt to replace lamp with the power on. Always unplug the power cord from the generator or power source when changing the lamp.
- **ALWAYS** allow a sufficient amount of time for the lamp to **cool** before changing. The possibility exists of severe burns.

CAUTION

- **NEVER** use force when installing the lamp. Excessive force could cause the lamp to break, causing bodily harm.

NOTICE

- **NEVER** leave any grease or oil residue on lamp surface when replacing or removing lamp. This can create hot spots, reducing the service life of the lamp.
- **ALWAYS** make sure lamp surface is clean and dry.
- **ALWAYS** replace with MQ recommended type lamp. See parts section of this manual.
- If applicable, **ALWAYS** make sure the lamp guard is installed correctly. **NEVER** deform the lamp guard.
- **NEVER** unplug the lamp's AC power cable during operation.
- **ALWAYS** have a **trained technician** to install and remove lamp or replace any damaged fixture wiring.

BALLOON SAFETY

WARNING

- To prevent serious burns, **NEVER** touch or unzip the balloon envelope when the lamp is on.



CAUTION

- **ALWAYS** keep the balloon away from sharp objects and excessive amounts of heat.

NOTICE

- To prevent balloon deformation, **NEVER** use lighting system in strong winds.
- **DO NOT** place the balloon inside its protective cover until the lamp has had a sufficient amount of time to cool down. This will prevent the balloon's nylon cover from being burned (touching the lamp surface).
- **ALWAYS** place the balloon inside its protective cover after each use. This will prolong the life of the balloon material, keeping it protected from harsh environmental elements.
- Replace balloon immediately if damaged. A damaged balloon will not inflate properly, and may become more damaged by touching the hot lamp surface.
- **DO NOT** use excessive force when zipping and unzipping the balloon. Be gentle with the zipper mechanism. If the zipper is broken, the balloon will become unusable.

SAFETY INFORMATION

GENERATOR SAFETY

If using a generator to power lighting system, refer to applicable generator manual safety information section.



ELECTRICAL SAFETY

DANGER

- Lighting system is equipped with a ground pin on the power plug. For your protection, **ALWAYS** complete the grounding path. **NEVER** insert the AC power plug into a 2-prong receptacle to operate lighting system.

When applying power to the lighting system, **ALWAYS** connect the AC power plug to a 3-prong receptacle that is grounded. The possibility exists of **electrical shock, electrocution and even death** if the lighting system is not grounded.

- **NEVER** operate lighting system or handle any electrical equipment while standing in water, while barefoot, while hands are wet or in the rain. A dangerous **electrical shock** could occur, causing **severe bodily harm or even death**.



- **ALWAYS** make sure the area above the lighting system is open and clear of overhead power lines and other obstructions. Contact with overhead power lines or other obstructions could result in equipment damage, **electrical shock, electrocution and even death**.

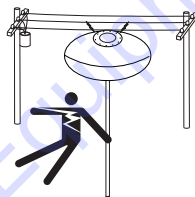

Power Cord/Cable Safety

DANGER

- **NEVER** let power cords or cables **lay in water**.
- **NEVER** use **damaged** or **worn** cables or cords. Inspect for cuts in the insulation
- **NEVER** grab or touch a live power cord or cable with **wet hands**. The possibility exists of **electrical shock, electrocution or death**.
- Make sure power cables are securely connected. Incorrect connections may cause **electrical shock** and damage to the lighting system.

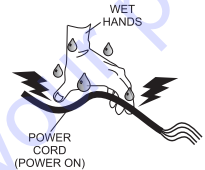

NOTICE

- **ALWAYS** make certain that proper power or extension cord has been selected for the job. See Cable Selection Chart in this manual.

SAFETY INFORMATION

LOADING AND UNLOADING

If lighting system is equipped with a transport lifting hook, refer to the following safety information.

CAUTION

- Before lifting, make sure that lighting system parts are not damaged and screws are not loosened or lost.
- **ALWAYS** make sure crane or lifting device has been properly secured to lifting hook of the equipment.
- **NEVER** lift the equipment while lighting system is running.
- Make sure the mast is completely lowered before lifting the lighting system.
- Use adequate lifting cable (wire or rope) of sufficient strength.
- Use one point suspension hook and lift straight upwards.

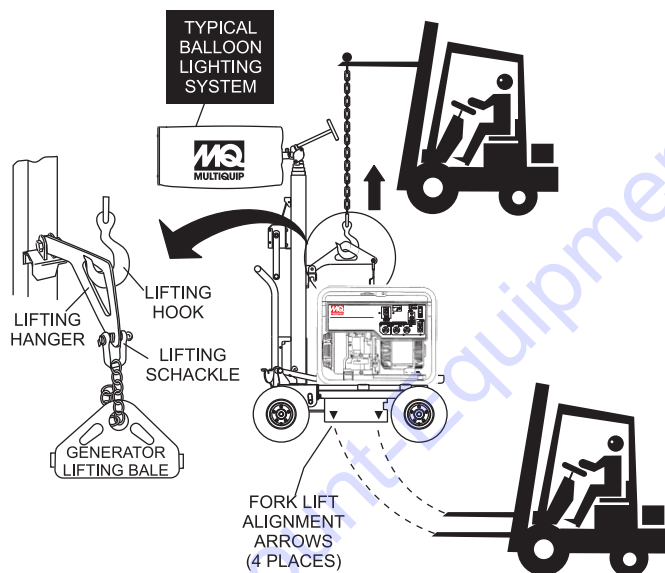

- Never allow any person or animal to stand underneath the equipment while lifting.
- **DO NOT** lift machine to unnecessary heights.

TRANSPORTING SAFETY

NOTICE

- When transporting the lighting system, if applicable, always place in **stow position** and place mast in its carrying case.
- **ALWAYS** remove balloon/lamp assembly from the mast when transporting lighting system. This will prevent damage to the bulb due to vibration.
- **NEVER** leave the balloon/lamp exposed during transport. Exposure to excess wind or rain could damage the balloon's nylon cover.
- **ALWAYS** place balloon inside its protective cover during transport. Be sure the cover is secured tightly around the balloon/lamp assembly.

Table 1. Specifications

GloBug	
Model	GB113BC
Input Voltage	120 VAC
Frequency	60 Hz Single-Phase
Max. Current	9.6 Amps
Wind Stability with Generator	65 mph (80.46 kph)
Weight (less generator)	276 lbs. (125 kg)
Lamp	
Lamp Type	(1)1000 Watt Metal Halidade
Lumens	112,000
Light Coverage (360°)	150 ft. (45.72 meters)
Surface Temperature (Longitudinal)	476.6°F (247°C) Max.
Surface Temperature (Transversal)	417.2°F (214°C) Max.
Fan Motor	
Balloon Fan Motor	115 VAC, 60 Hz
Max. Current	.360 Amps
Pressure	31.26 PSI (215.6 kPA)
Balloon	
Diameter	3.9 FT. (1.2 meters)
Material	Heat Resistant Nylon
Heat Resisting Temperature	320 ~ 356°F (160 ~ 180°C)
Melting Temperature	500°F (260°C)
Internal Temperature of Balloon	126°F (52°C) Average
Water Resistance	1,500 mm H ₂ O
Mast	
Number of Stages	GB113BC (3)
Maximum Height	14.58 FT. (4.44 meters)
Dimensions	See Figure 1, Table 2
Generator	See Specified Generator Manual

DIMENSIONS

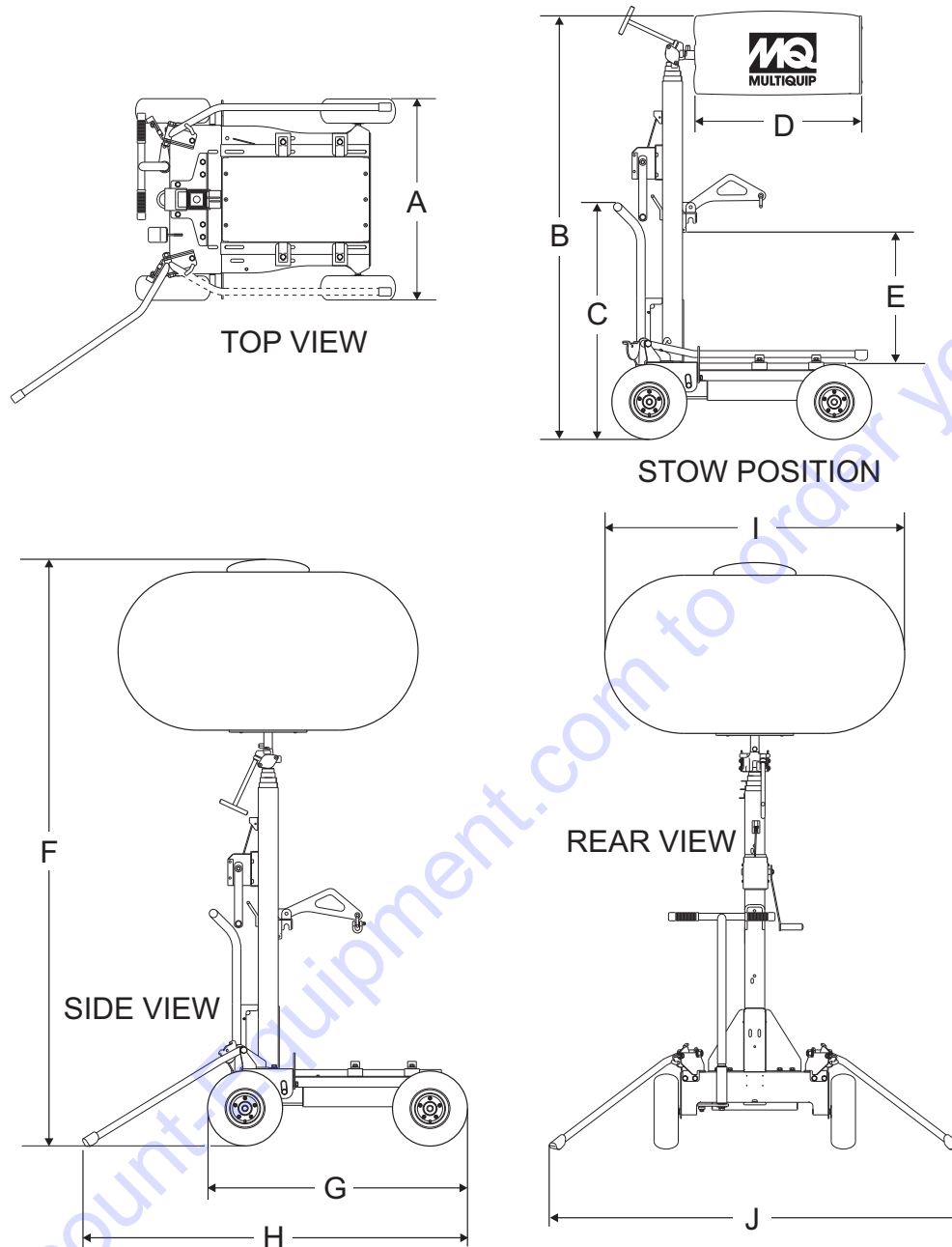

Figure 1. Dimensions

TABLE 2. DIMENSIONS

Reference Letter	Description	Dimension ft. (mm.)	Reference Letter	Description	Dimension ft. (mm.)
A	Wheel Base	2.62 ft. (800 mm.)	F	Max. Height (Mast Deployed Position)	14.58 ft. (4,445 mm.)
B	Height (Mast Stowed Position)	5.7 ft. (1,740 mm.)	G	Length (Front to Rear Wheel)	3.41 ft. (1,040 mm.)
C	Handle Height	2.88 ft. (878 mm.)	H	Length (Front Wheel to Outrigger)	5.08 ft. (1,550 mm.)
D	Balloon Bag Length	2.25 ft. (686 mm.)	I	Balloon Diameter	3.75 ft. (1,143 mm.)
E	Lift Hook to Platform	1.83 ft. (559 mm.)	J	Width (Outriggers Deployed)	5.24 ft. (1,600 mm.)

FLOODLIGHT FOOTCANDLE PLOT

Based on 360° glare-free coverage.

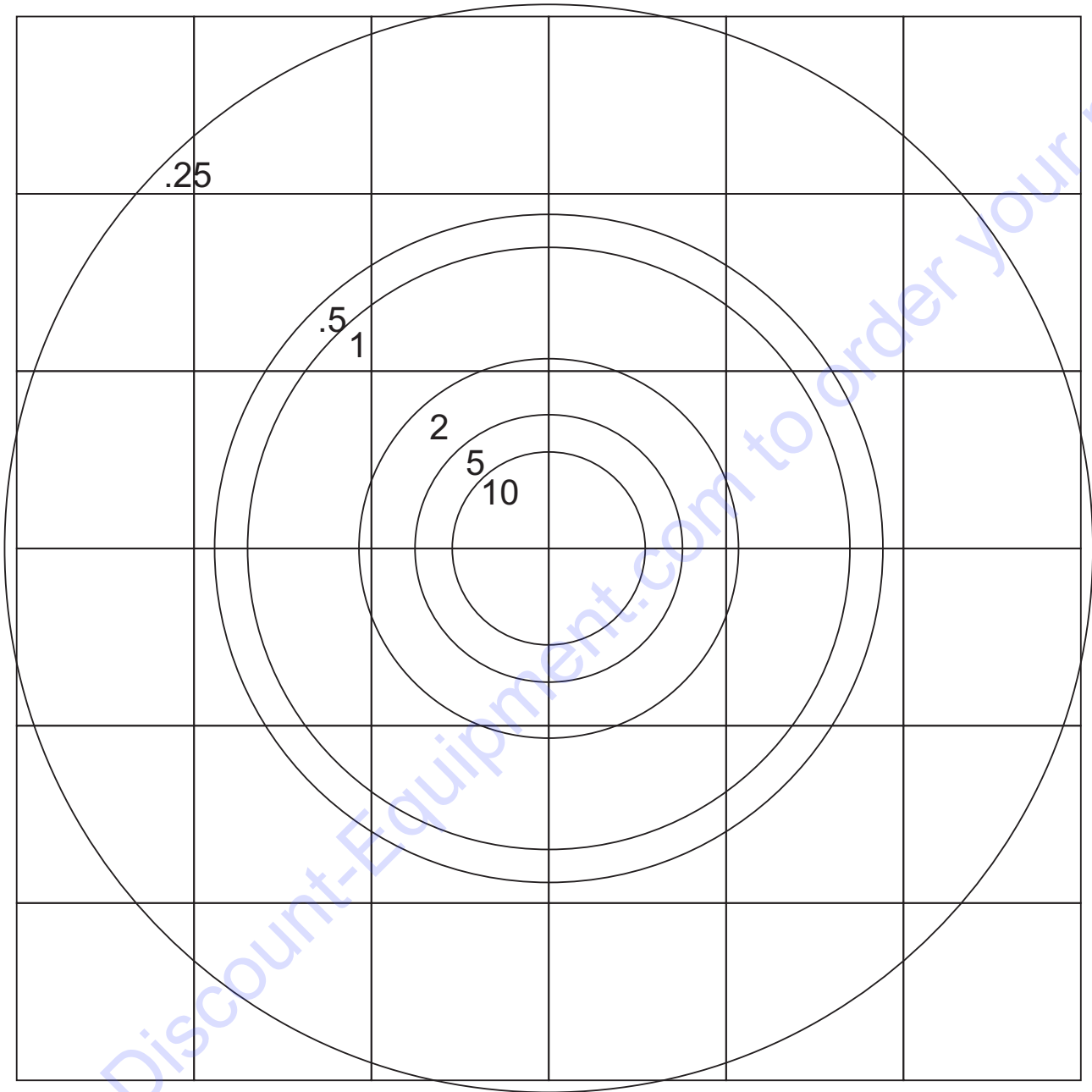

VALUES LISTED AS FOOTCANDLES

SCALE: 1 GRID = 50 FT. (15.24 METERS)

Figure 2. Floodlight Footcandle Plot (Bal120- Oval Shaped)

FLOODLIGHT FOOTCANDLE PLOT

Based on 360° glare-free coverage.

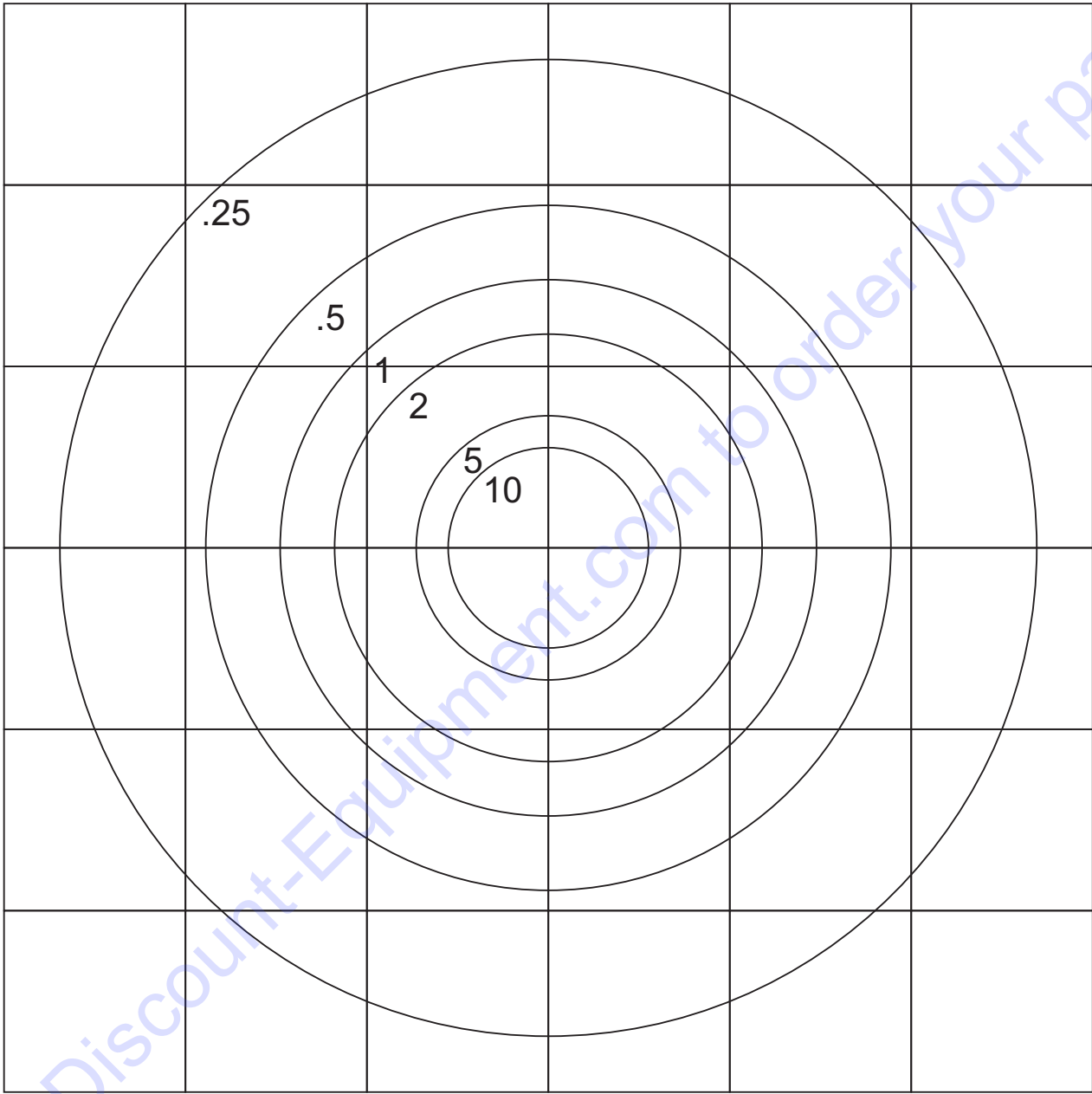

VALUES LISTED AS FOOTCANDLES

SCALE: 1 GRID = 50 FT. (15.24 METERS)

Figure 3. Floodlight Footcandle Plot (BAL120R-Reflector-Shaped Balloon)

FLOODLIGHT FOOTCANDLE PLOT

Based on 360° glare-free coverage.

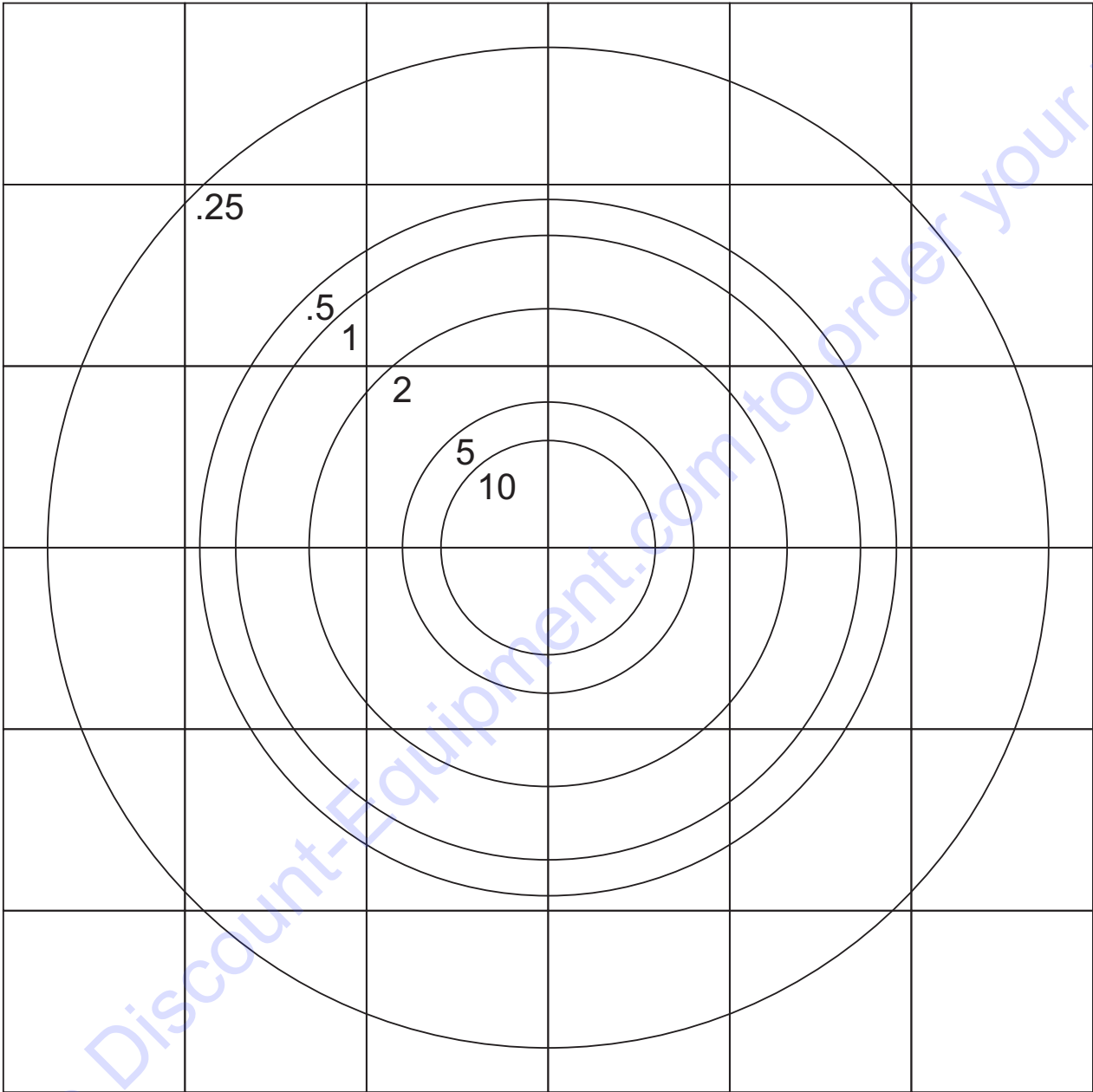

VALUES LISTED AS FOOTCANDLES

SCALE: 1 GRID = 50 FT. (15.24 METERS)

Figure 4. Floodlight Footcandle Plot (BAL-115D-Drum Shaped Balloon)

GENERAL INFORMATION

The Multiquip GloBug Lighting System is a general purpose floodlight tower intended for emergency and remote lighting conditions. The GloBug can be powered by a variety of Multiquip's series generators. Power requirements for running the GloBug are 120 VAC, 60 Hz @ 9.6 amps. The GloBug can be powered by any MQ portable generator with an output of 2.9 kW or greater.

Please read carefully the specified generator manual that will accompany your GloBug lighting system. This manual will explain how to operate and maintain the generator.

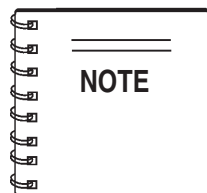

All information related to the generator will be referenced in a separate (supplied) "Operation and Parts Manual". Operation and maintenance of the generator **will not** be referenced in this manual.

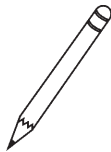

The lighting system of Multiquip's GloBug Lighting System is comprised of one "Metal Halide" 1000 watt lamp. This lamp has an output of 112,000 lumens. Typical lighting coverage is in excess 150 ft. (45.72 meters) in a 360 degree pattern.

Located underneath the generator support platform is a weather resistant ballast box that contains the ballast for starting the floodlight. The floodlight is activated by an ON/OFF switch located at the base of the mast.

For ease of service or transport, the floodlight is equipped with a quick-disconnect connector that allows the lamp fixture to be removed quickly. This feature is extremely useful during transport of the lighting system over rough terrain. It is always best to remove the floodlight and pack it safely so it will not be damaged.

Balloon Envelopes

The GloBug can be configured with a variety of balloon envelopes (canopy). Please contact Discount-equipment for the balloon of your choice. The GloBug, Model GB113BC is shipped from the factory with the drum type balloon.

The lighting system can be raised vertically in excess of 14.58 feet (4.44 meters) by means of a manual winch. The tower tensioning system is designed to provide the necessary tension to safely control the pivot of the tower. Outriggers must always be deployed prior to raising the mast.

! DANGER - GloBug Overhead Obstructions

ALWAYS make sure the area above GloBug is open and clear of overhead power lines and other obstructions. The tower extends in excess of 14.58 ft. (4.44 meters). Contact with overhead powerlines or other obstructions could result in equipment damage, **Serious Injury or Death!**

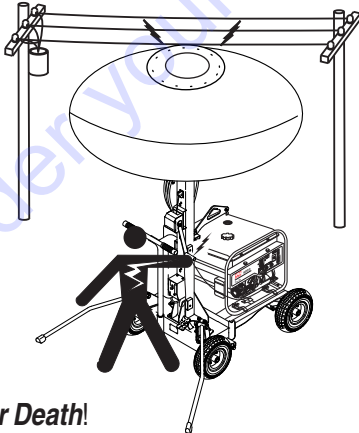
A line drawing diagram showing a person operating a piece of equipment on wheels. Above the person is a large, circular, dome-shaped structure (the GloBug) supported by a vertical mast. The mast is connected to a horizontal structure that looks like a winch or tensioning system. Arrows point to the area above the dome, indicating the need to clear it of obstructions. The person is standing next to the equipment, which has a generator on top.

Alarm Buzzer

The GloBug is equipped with a "Balloon Alarm" feature. This alarm will sound if the lamp is on and the balloon attempts to make contact with the **hot!** surface of the lamp. This alarm is intended to inform the operator that a potential burn hazard exists between the lamp surface and the balloon material.

Always allow the lamp to cool down before removing the AC power from the GloBug. In the event the balloon begins to deflate during normal operation, immediately place the GloBug's ON/OFF switch in the OFF position.

Machine Safety Decals

The GloBug is equipped with a number of safety decals. These decals are provided for operator safety and maintenance information. The decal illustrations shown in the parts section of this manual show the decals as they appear on the machine. Should any of these decals become unreadable, replacements can be obtained from your dealer.

COMPONENTS

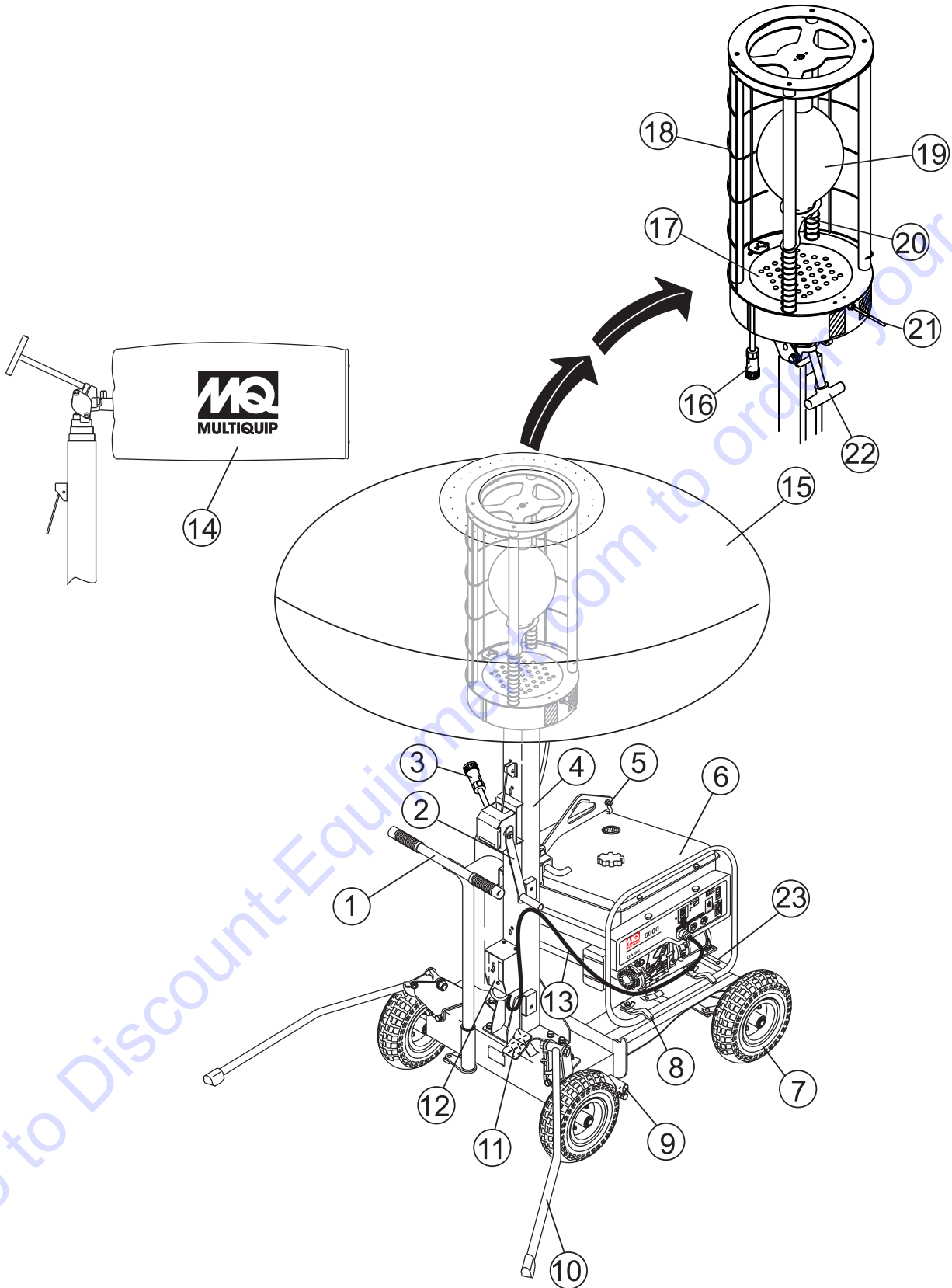



Figure 5. Major Components

Figure 5 shows the location of the controls and components for the GloBug Lighting System. The functions of each control is described below:

1. **Steering Handle** – The GloBug can be moved in either a forward or reverse direction by pulling back or pushing forward on the T-handle. In addition the front wheels are designed to turn in the opposite direction of the T-handle placement thus allowing the GloBug to turn either left or right.
2. **Mast Winch** – Use this mechanical winch to raise and lower the mast. Always be on the lookout for overhead obstructions. Keep immediate area free of bystanders and debris when raising the mast.
3. **Lamp Power Cable (Generator)** – Connect this quick-disconnect cable plug (generator-side) to the lamp power cable plug.
4. **Mast** – This mast is comprised of three separate stages. The mast can be raised in excess of 14.58 ft. (4.44 meters). Again when raising the mast, always be on the lookout for overhead obstructions.
5. **Lift Hanger** – When lifting of the GloBug is required always use a suitable lifting device of adequate lifting capability. **NEVER** stand underneath the GloBug while it is being lifted.
6. **Generator** – MQ GA-Series type generator. This generator will supply the necessary power to run the GloBug. For operation of generator read generator Operation Manual supplied with GloBug.
7. **Tires** – The GloBug uses 4 pneumatic type tires. Replace with only recommended type tire. **NEVER** allow the rear tires to go flat. This could adversely affect the braking system. Inflate tires to 35.5 psi (245kPa).
8. **Locking Clamps** – To secure the generator to the GloBug cart platform, place clamps (4) around the pipe frame of the generator. Tighten securely to prevent movement.
9. **Brake Pad** – When the brake pedal is pressed, this pad will strike and hold the rear tires in place. Make sure rear tires are inflated to the correct air pressure.
10. **Outriggers** – **ALWAYS** deploy the outriggers when raising the mast.
11. **Brake Pedal** – Step on this pedal to apply the brakes. To release the brakes, press down on brake pedal again.
12. **ON/OFF Switch** – Place this switch in the **ON** position to turn on the lamp. To turn off the lamp place in the down position (**OFF**). Please wait for approximately 10 minutes before attempting to turn the lamp back on.
13. **Power Cable** – Connect this cable to a 120 VAC, 60 Hz power source.
14. **Balloon Storage Bag** – Store the balloon in this storage bag when the GloBug is not in use. Allow a sufficient amount of time for the lamp to cool down before placing balloon inside storage bag. Possibility exists of balloon getting burned.
15. **Balloon** – This balloon is made of heat resistant nylon, with a diameter of 3.9 ft. (1,150 mm). The balloon shall be inflated to a pressure of 31.26 psi (215.6 kPa).
16. **Lamp Power Cable (Balloon)** – Connect this quick-disconnect cable plug (balloon-side) to the generator power cable plug.
17. **Fan Motor (Blower)** – This electric motor is responsible for inflating the balloon. It will supply a pressure of 31.26 psi (215.6 kPa). Please note that the balloon will begin to inflate as soon as power is applied to the GloBug. The OFF/ON switch **does not** control the electric fan motor.
18. **Lamp Guard** – This guard (cage) protects the lamp from being hit by objects.
19. **Lamp** – 1000 watt metal-halide type lamp. Replace with only MQ recommended type lamp. Always allow a sufficient amount of time for the lamp to **cool down** before changing.
20. **Lamp Holder** – Screw lamp into this holder. If lamp becomes difficult to screw into holder or holder is damaged, replace holder.
21. **Balloon Alarm Buzzer** – Will sound during normal operation if the balloon attempts to make contact with the lamp's **hot!** surface. If this condition occurs, immediately place the GloBug's ON/OFF switch in the OFF position.
22. **Adjust Lever** – This lever allows the lamp to be positioned up or down. Turn counterclockwise to release lamp and position. Turn clockwise to tighten.
23. **Ballast Compartment** – Provides the necessary electronics to light the lamp. To gain access to the ballast compartment the generator must be removed from the cart platform.

! CAUTION - Read Manual

Please read this entire manual carefully before attempting to operate the GloBug. Failure to read this manual could cause damage to the GloBug and serious injury to the operator.



- Lift up on each outrigger (2) from its stow position, rotate backwards and place it in the deployed position, as shown in Figure 8. The outriggers will automatically lock in place once they touch the ground,

GloBug Setup

- Using the T-handle (Figure 6) place the GloBug on a **firm level surface** so that it will not slide or turn over.

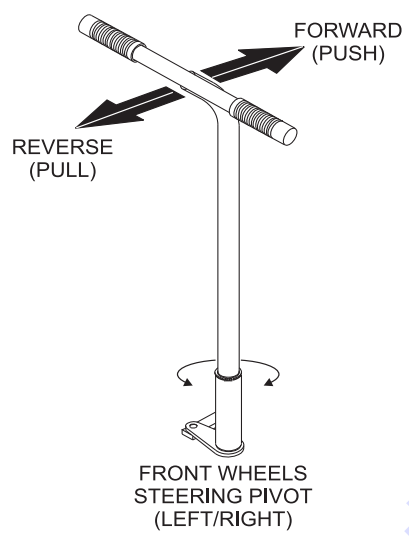

Figure 6. T-Handle (Directional Control)

- To apply the parking brake (Figure 7), step on the brake pedal and pull back on the T-handle. This will lock the rear wheels. For additional safety use chock blocks to prevent rolling.

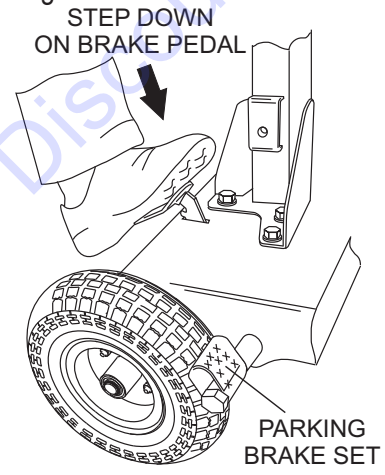

Figure 7. Parking Brake (Set Position)

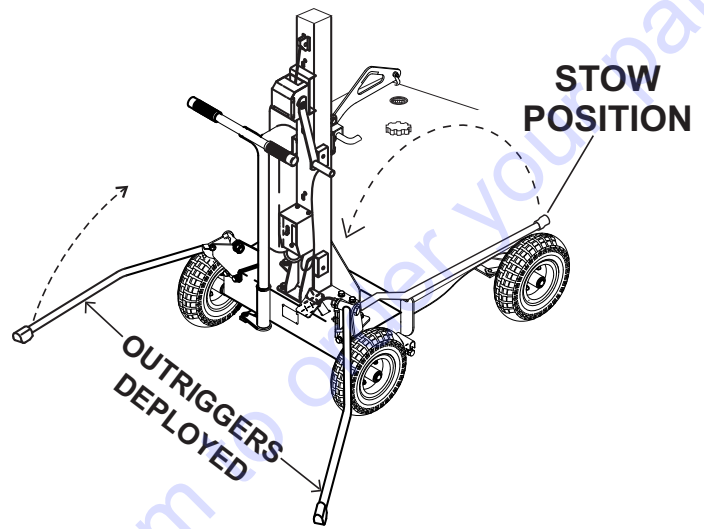

Figure 8. Outriggers (Deployed Position)

- Expose the balloon by pulling down on the velcro tabs and unzip the protective cover as shown in Figure 10. Next, fold the protective cover into itself and zip.

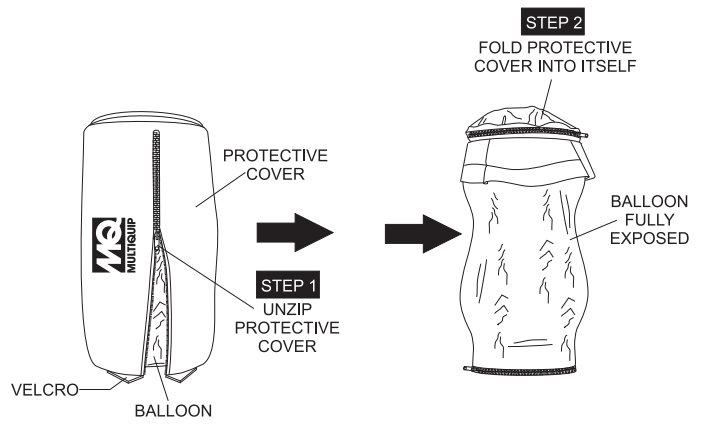
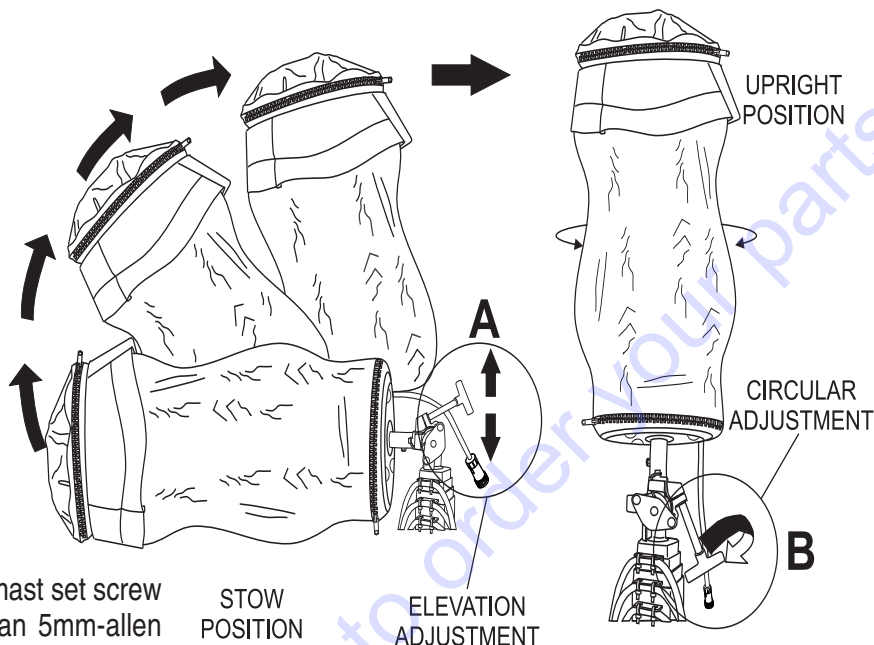

Figure 9. Exposing the Balloon.

- To position the balloon, simply loosen the adjustment lever by turning it counter-clockwise and either push down or up on the lever. Pushing **down** on the lever will cause the balloon to rise. Pushing **up** on the lever will allow the balloon to be lowered. See insert A in Figure 10.
For circular positioning, swing the lever to the desired position. See insert B in Figure 11.



- Before raising the mast, make sure the mast set screw (Figure 11) is securely tightened (use an 5mm-allen wrench to tighten). This will prevent the balloon/lamp assembly from falling off. In addition make sure the power cable from the generator is connected to the lamp power cable.

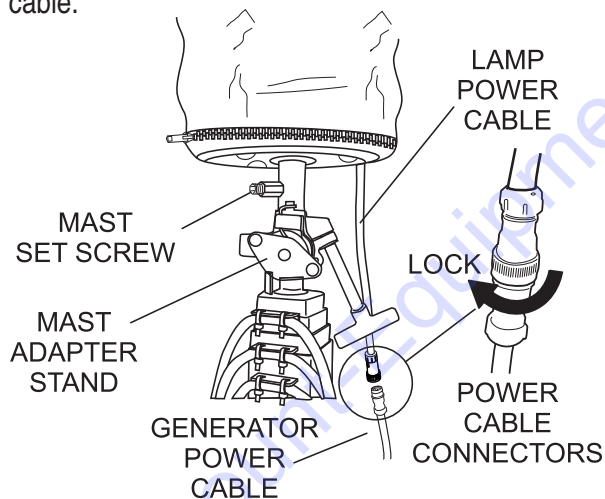

Figure 11. Mast Set Screw/Power Connections

CAUTION - MAST PINCH POINT
When raising or lowering the mast, keep hands and fingers clear of the various mast sections, this will prevent hands and fingers from getting pinched.

- Using the mechanical winch (Figure 12), **raise** the mast to the desired height. Turn winch handle clockwise to raise mast.

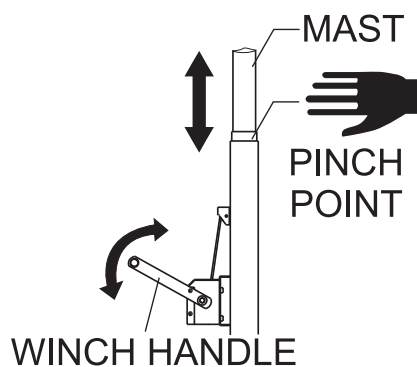

Figure 12. Mechanical Winch Handle

SETUP/OPERATION

! DANGER - HIGH VOLTAGE POWER LINES

When raising mast, **ALWAYS** be on the lookout for overhead obstructions such as high voltage power lines. The possibility exists of electrocution, even death! if the GloBug comes in contact with **high voltage power lines**.



Applying Power

1. Make sure the power ON/OFF switch (Figure 13) located near the bottom of the mast is in the **OFF** position.

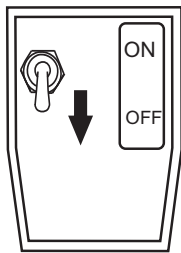

Figure 13. Power OFF/ON Switch (OFF Position)

! CAUTION - READ GENERATOR MANUAL

Before attempting to operate the generator, **READ** the entire operation section of the manual. Failure to read manual could cause severe damage to the equipment and bodily harm to the operator.



2. The GloBug has a power requirement of 120 VAC, 60 Hz @ 9.6 amps. Connect the GloBug's AC power cord to the 120 VAC twist-lock receptacle (Figure 14) on the the supplied generator.

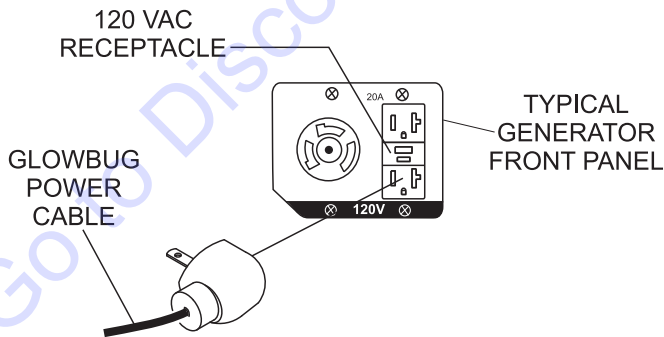

Figure 14. 120 VAC Receptacle

3. Start the generator as referenced in the "Start-up Section" of the supplied generator manual.

4. Notice that the balloon envelope will begin to deploy as soon as power is applied by an active generator. This function **is not** controlled by the power ON/OFF switch.
5. Wait until the balloon is fully deployed before attempting to turn on the lamp. The possibility exists of the balloon getting burned (touching the lamp).
6. If the balloon is fully deployed, place the GloBug's ON/OFF switch (15) in the **ON** position.

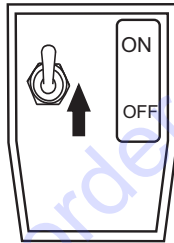

Figure 15. Power OFF/ON Switch (ON Position)

7. The lamp should now be on. If the lamp is not on, check all connections and repeat steps 1 through 6. If the lamp still does not come on contact Discount-equipment.

Shutdown

1. Place the power ON/OFF switch (Figure 16) in the **OFF** position.

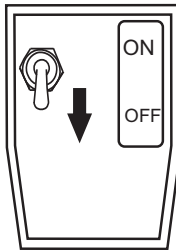

Figure 16. Power OFF/ON Switch (OFF Position)

! CAUTION - LAMP COOL DOWN

Allow a sufficient amount of time (15-20 minutes) for the lamp (Figure 17) to **cool down** before turning off generator. The possibility exists of the balloon getting burned (touching the lamp).

2. Disconnect the GloBug's AC power cable from the generator. The balloon should begin to deflate.
3. Shutdown generator as referenced in the "Shutdown Section" of the supplied generator manual.

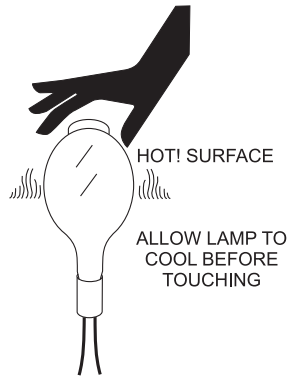

Figure 17. Hot Lamp Surface

4. Using the mechanical winch (Figure 5, item 2), **fully lower** the mast. Turn winch handle counter-clockwise to lower mast.
5. Using the adjustment lever (Figure 5, item 22) place the balloon/lamp assembly in the stow position.
6. Unzip the protective cover as shown in Figure 18, and place cover over balloon/lamp assembly.

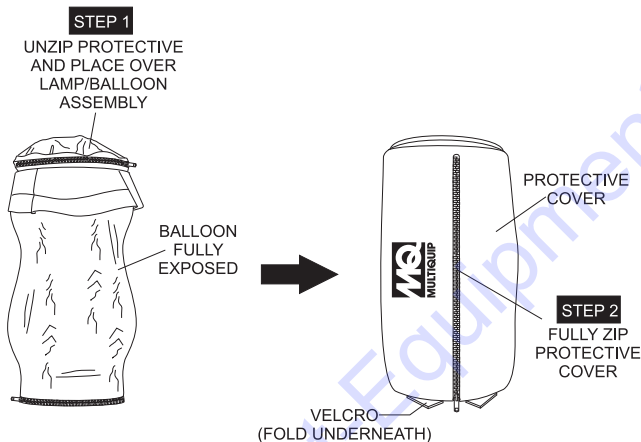

Figure 18. Covering the Lamp/Balloon Assembly

7. To unlock outriggers, push downward on the counterweight lever indicated by arrow (Figure 19). Grab hold of outrigger, pull upward, push down and place in stow position (Figure 20).

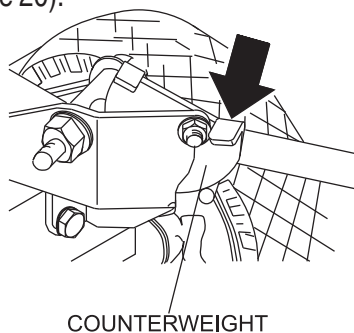

Figure 19. Outriggers (Released)

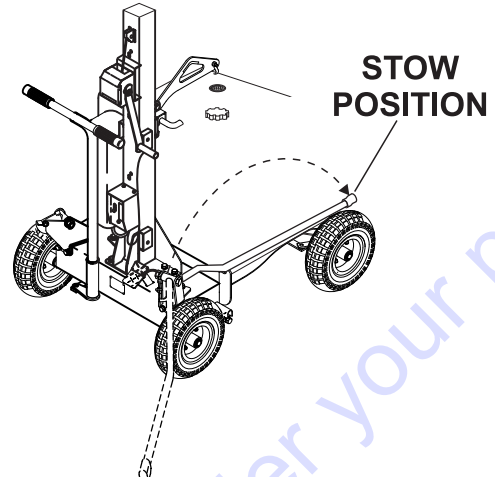

Figure 20. Outriggers (Stow Position)

8. Press down on the top of the brake pedal (Figure 21) and hold, then release. This action will dis-engage the brake mechanism and allow the GloBug to be moved.

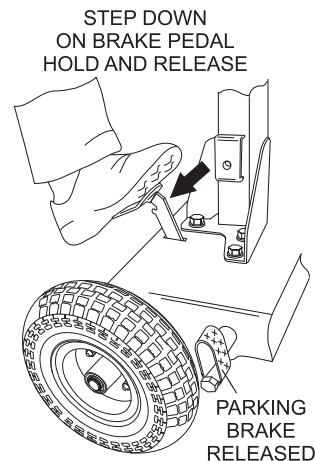



Figure 21. Parking Brake (Release Position)

Storage

1. Wipe and dirt or foreign matter that may have accumulated on the GloBug during operation. Use a mild detergent to clean the unit. **DO NOT** spray the engine with water.
2. Avoid storing the GloBug in areas that can be exposed to rain, harsh elements, and high humidity.
3. Place the GloBug in a clean dry location away from dirt and debris.

CAUTION - READ SAFETY GUIDELINES

Before performing any maintenance procedures, be sure to **READ** the lamp, balloon, and general safety guidelines in this manual. Failure to **read** and **understand** these safety guidelines could cause severe equipment damage and bodily harm.



CAUTION - BALLOON ZIPPER SAFETY

DO NOT use excessive force when zipping or unzipping the balloon. The possibility exists of the zipper tearing, which would make the balloon unusable.



Removing the Lamp/Balloon Assembly

1. Place the lamp/balloon assembly in the **STOW** position.
2. With a 5 mm allen wrench, loosen the set screw (Figure 22) that secures the lamp to the mast adapter stand.

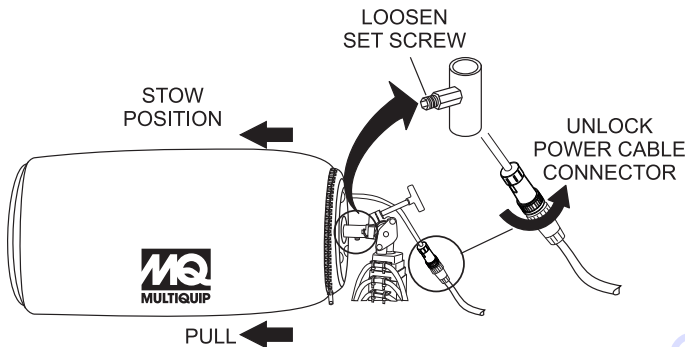

Figure 22. Removing the Balloon/Lamp

3. Disconnect the lamp power cable as shown in Figure 22, and slide the balloon/lamp forward from the mast adapter stand. Place lamp/balloon assembly on a suitable work bench that is free of dirt, and sharp objects that could damage the balloon.

Removing the Lamp

1. Expose the balloon (Figure 23) by pulling down on the velcro tabs and unzip the protective cover as shown in Figure 18. Next, fold the protective cover into itself and zip.

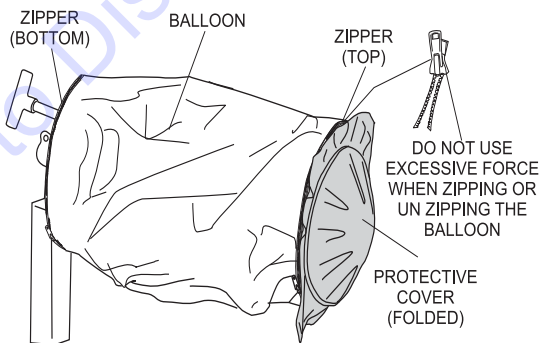

Figure 24. Exposing the Balloon

2. Unzip the zipper (Figure 23) at the bottom of the balloon and roll the balloon envelope upwards to expose the lamp (Figure 24). Remove the lamp guard to gain access to the lamp. **DO NOT** use excessive force when un-zipping the balloon.

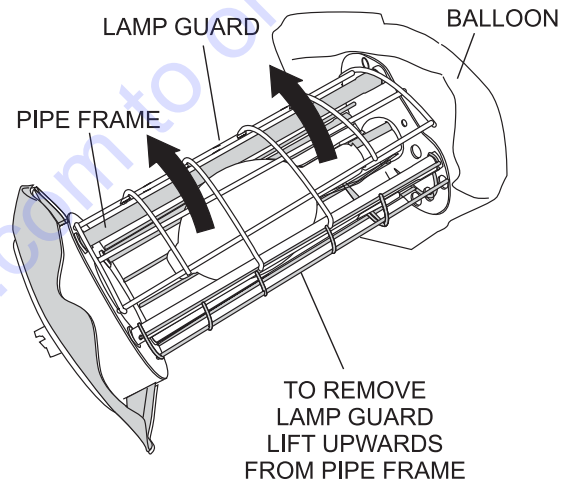

Figure 24. Removing the Lamp Guard

3. Push down and hold the lamp holder (spring loaded) away from the lamp (Figure 25). Unscrew the lamp (turn counter-clockwise) from the lamp socket.

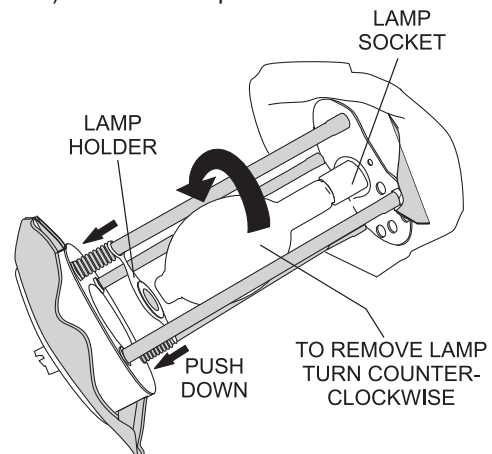

Figure 25. Removing the Lamp

Installing a New Lamp

1. When installing a new lamp (Figure 26) use only MQ recommended type lamp. See parts section of this manual. Failure to use correct type lamp could adversely affect lighting capability and may cause damage to the equipment.
2. Push down and hold the lamp holder (spring loaded) away from the lamp. Screw the lamp (turn clockwise) into the lamp socket. Gently place the lamp holder firmly over the top of the lamp. This will prevent the lamp from touching the lamp guard or pipe frame.

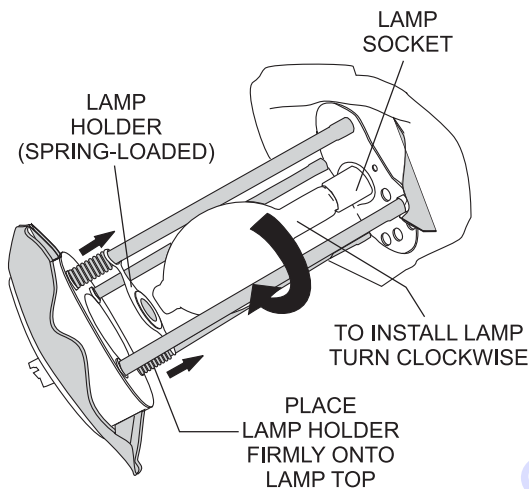

Figure 26. Installing the Lamp

Re-Installing the Lamp/Balloon Assembly

1. Reinstall the lamp guard (Figure 27). Be careful not to install the lamp guard in the wrong direction.

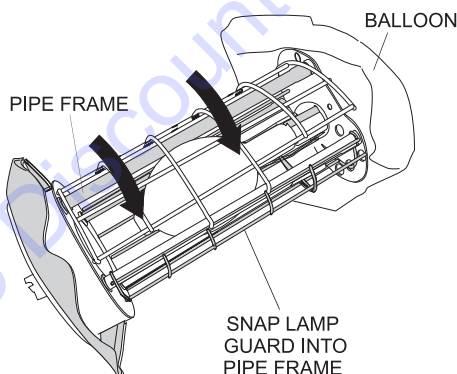

Figure 27. Installing the Lamp Guard

2. Zip up the zipper at the bottom (Figure 23) of the balloon and pull down the balloon envelope to cover the lamp
3. Place the lamp/balloon assembly back onto the mast adapter stand (Figure 22).
4. With a 5 mm allen wrench, tighten the set screw to 28 ~ 38 ft. lbs (38 ~ 51 N-m) to secure the lamp to the mast adapter stand
5. Reinstall the protective cover over the balloon/lamp assembly. Be sure to fold the velcro tabs.
6. Reconnect the power cables.

Replacing the Balloon

1. Follow the procedures as outlined in the "Removing the Balloon Lamp" assembly section.
2. Unzip the zipper at the bottom and top of the balloon. Slide the balloon over the top of the lamp guard as shown in Figure 28.

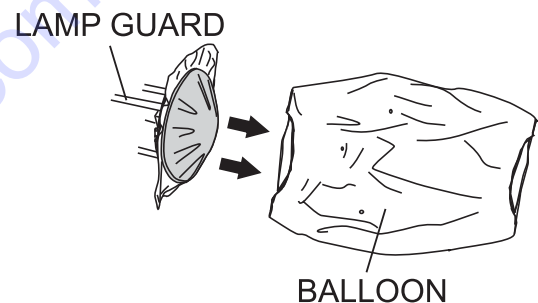

Figure 28. Removing the Balloon

3. Slide the new balloon over the top of the lamp guard as shown in Figure 29. Zip up the zipper at the bottom and top of the balloon.

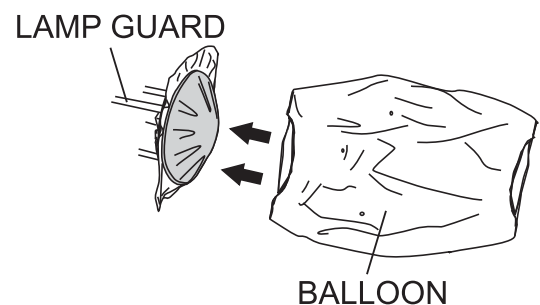

Figure 29. Removing the Balloon

Check Cable Wear

The wire rope (cable) that raises and extends the mast is a very important part of the GloBug lighting system. Following the procedure below when replacing wire rope (cable).

⚠ DANGER - Lighting System Cable System

Wire rope (cable) will fail if it is worn, frayed, misused, crushed, kinked or damaged in any way. **ALWAYS** check the cable and pulley for any abnormalities before use.

DO NOT use it if there is even the slightest cause for concern and replace any damaged cable or pulley *immediately*.

Removing the Lamp/Balloon Assembly

1. Place the lamp/balloon assembly in the **STOW** position.
2. With a 5 mm allen wrench, loosen the set screw (Figure 22) that secures the lamp to the mast adapter stand.
3. Remove the lamp/balloon assembly from the mast adapter stand and set aside in a safe place where it will not get damaged.

Removal of Winch

1. Fully lower the mast to its vertical resting position.
2. Remove the four retaining screws and washers (Figure 30) that secure the winch cover. Remove the winch cover.
3. Loosen the winch cable retaining screw. Pull and remove the winch cable from the locking pin.
4. Remove the three retaining screws and washers that secure the winch to the mast. Remove the winch.

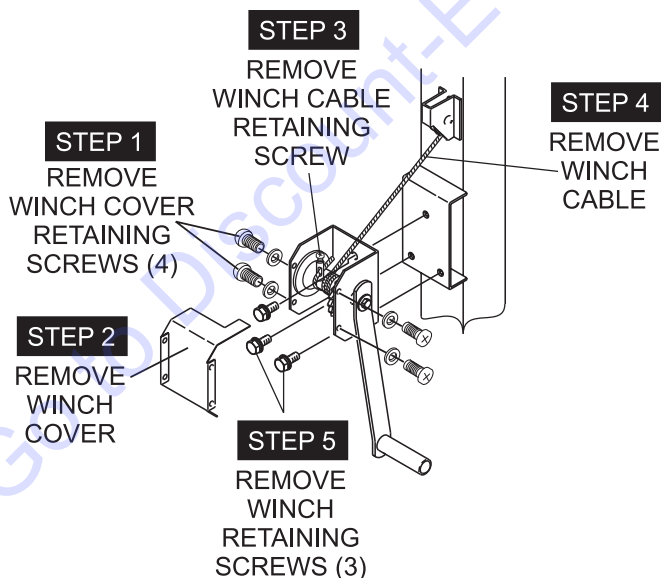

Figure 30. Winch/Cable Removal

Removing the Hanger

1. Remove the M12 x 40 bolt (Figure 31) from the hanger support assembly, then remove the hanger. Set hanger aside in a safe place where it will not get damaged.

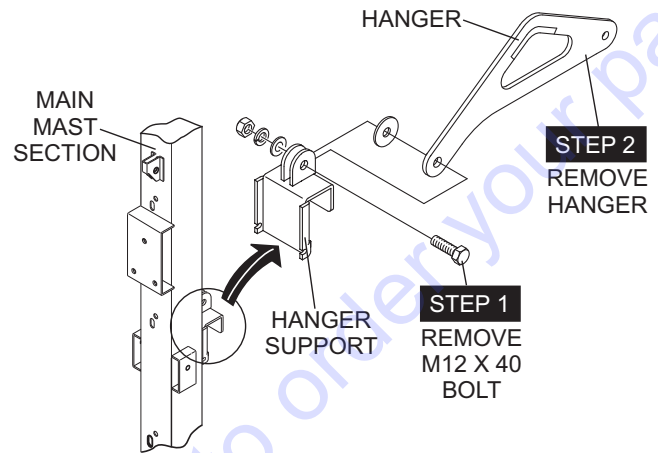

Figure 31. Removing the Hanger

Removing the Lamp Cable

1. Cut all the cable zip ties (Figure 32) that secure the lamp cable to the various mast sections.
2. Remove the lamp cable from the various mast sections and set cable aside in a safe place where it will not get damaged. Mark the order of the cable sections so that they can be placed back in the same order. Make sure cable is laid flat and out of the way so that personnel will not trip over it.

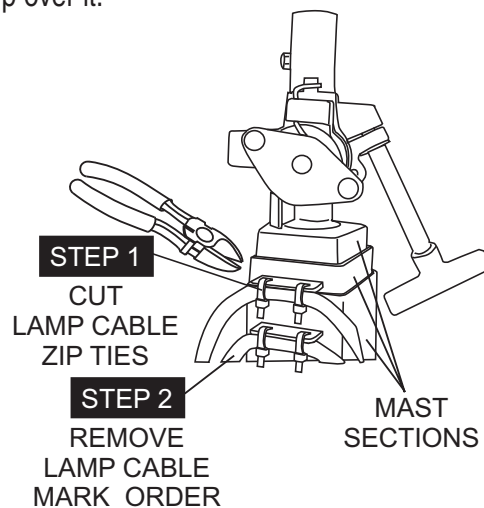

Figure 32. Cutting the Lamp Cable Zip Ties

Pulling-Out the Mast Sections

1. Grab hold of the main mast (Figure 33) and begin pulling the mast sections upwards. Start with second mast, and then the third mast.
2. From the main mast, pull the winch cable wire to release the safety stopper pulley at the second mast.

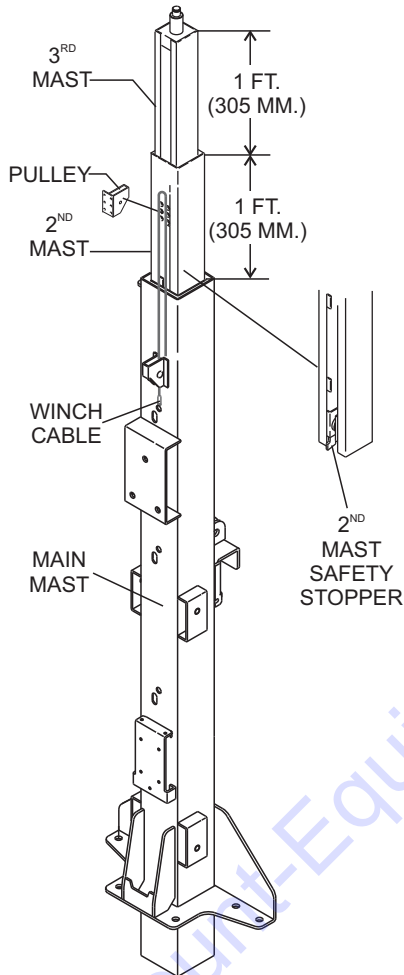
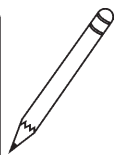
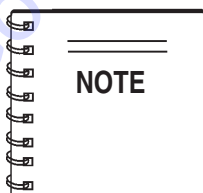

Figure 33. Mast Sections

3. Each mast section should be equally spaced about 12-inches from the preceding mast section. See Figure 33.



If the winch cable wire cannot be pulled because of breakage of the wire itself, the **safety stoppers** installed in the second mast will lock automatically at the places indicated by the arrows in Figure 34.

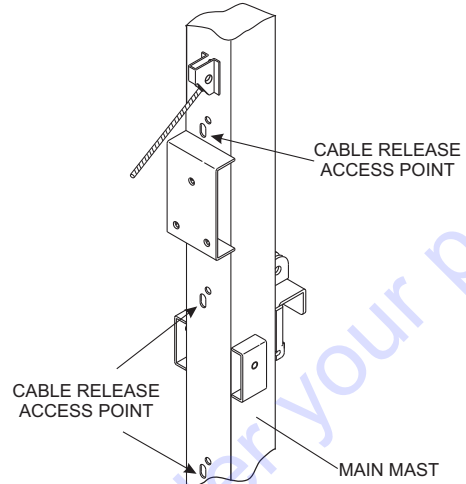

Figure 34. Cable Release Access Point

5. To release the safety stopper without pulling the cable wire when removing the second mast from the first (main mast), insert a screwdriver (Figure 35) nearest the hole where the latch is caught. Press down on the screwdriver to lift the pulley inside the second mast upward. Remove the screwdriver lifting the second mast upwards as the latch is being pulled back. The second mast should now be able to be pulled out from the first mast.

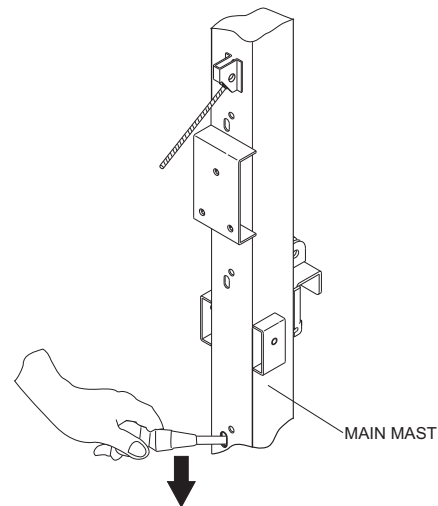

Figure 35. Releasing the Safety Stop Latches

! WARNING - Mast Service Safety
The mast sections are heavy and awkward to handle. Use proper lifting devices and procedures when servicing the mast and its components.

Installation of Winch Cable

1. Route (pass) a new winch cable through the main mast pulley **A** (Figure 36).
2. Route the winch cable around the **upper pulley D** of the third mast section from back to front.
3. Route the winch cable around the **upper pulley C** of the second mast section from back to front.

5. Route the winch cable around the **lower pulley B** of the second mast from front to back.
6. Continue pulling the cable and slide down the mast, being careful not to activate the cable stop latches.
8. Route the cable around the pulley of the first mast **A**.
9. Place the second mast into the main (first) mast. Next, place the third mast into the second mast.

! CAUTION - Winch Cable Safety Stopper

When placing the second mast into the main mast (first), pinch (squeeze) the pulley and pin with pliers (Figure 37) to hold the stopper (cable latch). This will keep the cable stop latch from being activated.

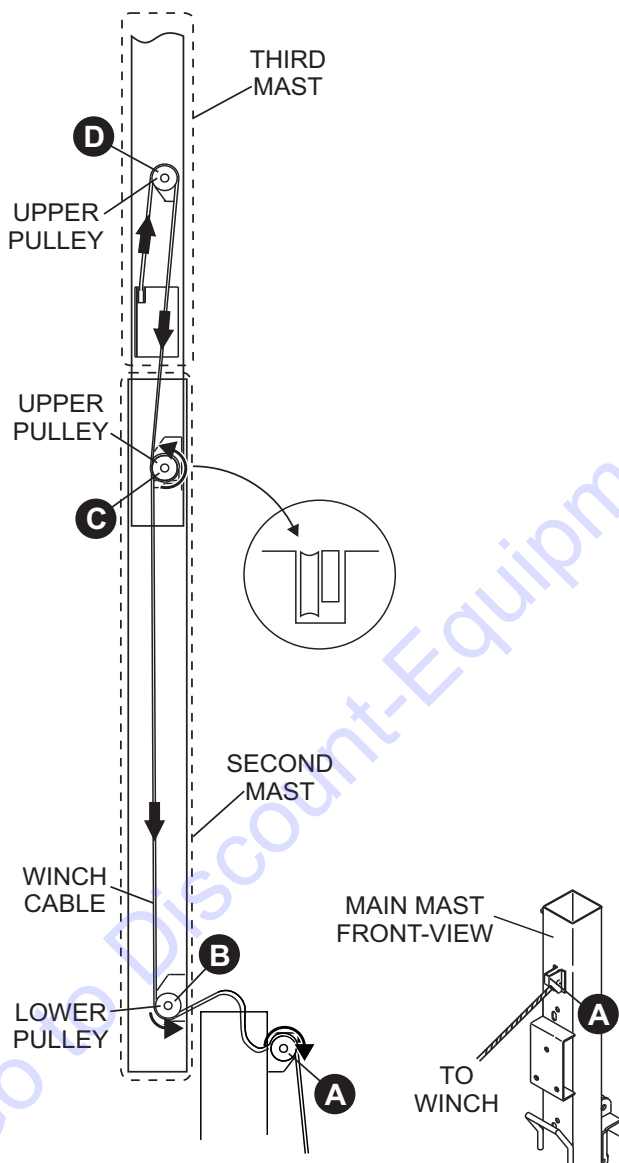

Figure 36. Attaching the Winch Cable

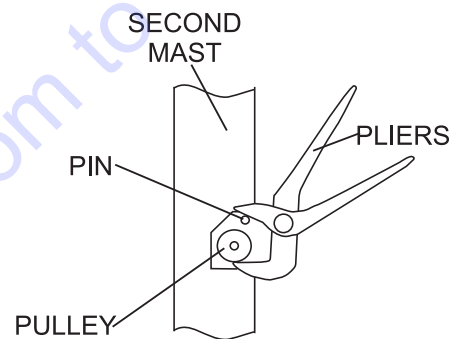

Figure 37. Bypassing Cable Stop Latch

10. Route the tip of the winch cable (Figure 38) through the eyelet retaining stud. Insert cable retaining screw at top of stud and tighten.

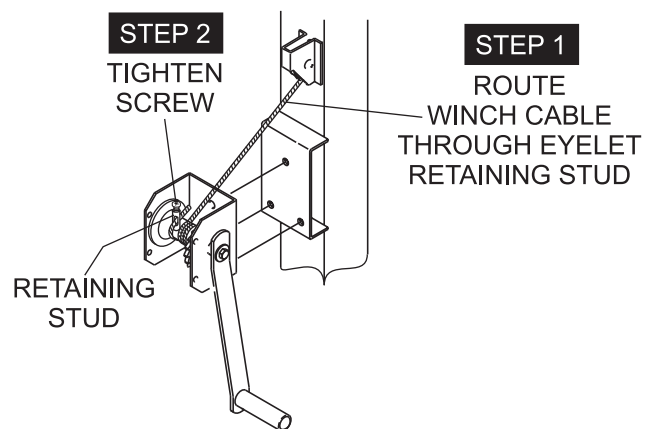

Figure 38. Connecting the Winch Cable to the Winch

Installation of Winch

1. Reinstall the three retaining screws (Figure 30) and washers that secure the winch to the mast. Tighten screws between 24~ 33 ft-lbs. (33 ~ 45 N-m).
2. Install the four retaining screws and washers (Figure 30) that secure the winch cover. Tighten securely.
3. Turning the winch handle clockwise, wind the cable tightly around the winch shaft.
4. Raise, extend, retract and lower the mast several times to verify correct operation.
5. If the winch malfunctions, such as defective brake mechanism, replace entire winch assembly immediately.

Installing the Hanger

1. Reinstall the M12 x 40 bolt (Figure 31) that supports the hanger onto the main mast. Tighten bolt between 28~ 38 ft-lbs. (38 ~ 51 N-m).

Installing the Lamp Power Cable

1. Check the entire lamp cable for any signs of wear, such as cuts or frays. If the cable is damaged in any way, replace entire cable. **DO NOT** use a worn or damaged cable to operate the GloBug. The possibility exists of shock or electrocution.
2. Using zip ties connect the lamp power cable to the various mast sections as shown in Figure 33. Remember to connect the lamp cables to the mast in the same order that they were removed.
3. Cutoff any excess zip tie material.

Ballast Box Removal

WARNING - HOT SURFACE (BALLAST)

Dangerous conditions exist inside the ballast compartment. Please use extreme caution when performing maintenance on the ballast box. **NEVER** touch the ballast or ballast cover while the lamp is on. These components generate an extreme amount of heat, which makes their surfaces very **hot!** **ALWAYS** allow the ballast box and cover surface to cool down before servicing.



DANGER - HIGH VOLTAGE (BALLAST)

The electronic components of the ballast generate high voltage conditions. These conditions can be **lethal and cause bodily harm, even death.** When performing maintenance or troubleshooting, have only experienced personnel work on the ballast.



The ballast electronics are located within the cart frame of the GloBug. To gain access to the ballast (Figure 39), remove the 4 retaining bolts and washers (M10 X 25) that secure the ballast cover to the cart.

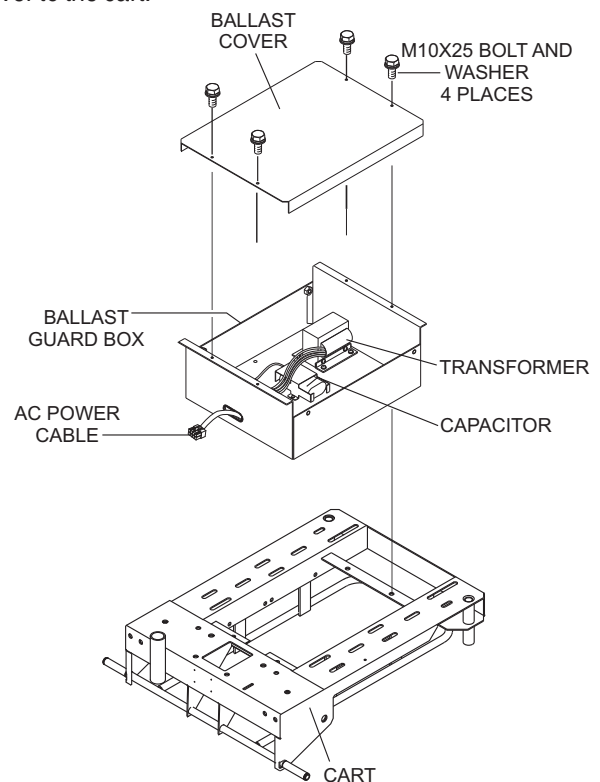

Figure 39. Removing the Ballast

Filter Replacement

! WARNING - HOT SURFACE (LAMP FRAME)

DO NOT replace filter immediately, allow a sufficient amount of time for the lamp assembly to cool down before changing filter.



1. Remove the balloon as described in the "Removing the Lamp/Balloon" section.
2. Disconnect the lamp power cable as shown in Figure 22.
3. Rotate the balloon/lamp base assembly so that the filter is facing upwards. See Figure 40.

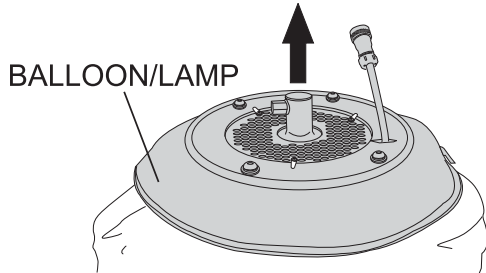

Figure 40. Balloon/Lamp Placement

4. Turn the three locking tabs (Figure 41) inward to release the plate. Remove plate and filter.

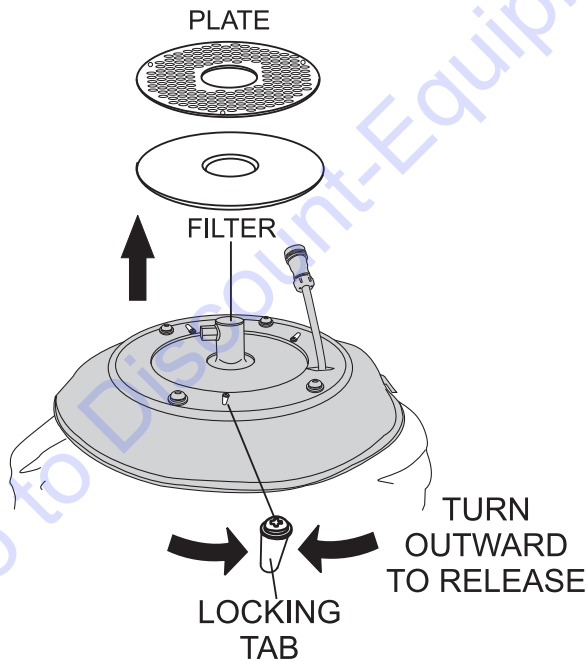

Figure 41. Filter Removal

5. Install a new filter over the brace as shown in Figure 42. Be sure to align the **cut of the filter** over the brace.

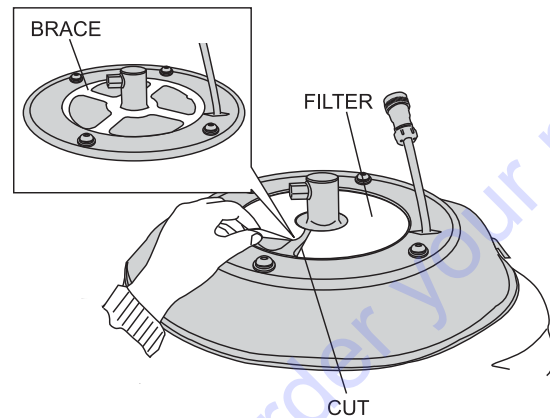

Figure 42. Filter Placement

! CAUTION - FILTER ALIGNMENT

When placing the filter element, always align the cut of the filter on top of the brace. This will keep the filter from being dislodged and getting damaged.

6. Turn the three retaining tabs (Figure 43) outward so that they touch the lamp base.

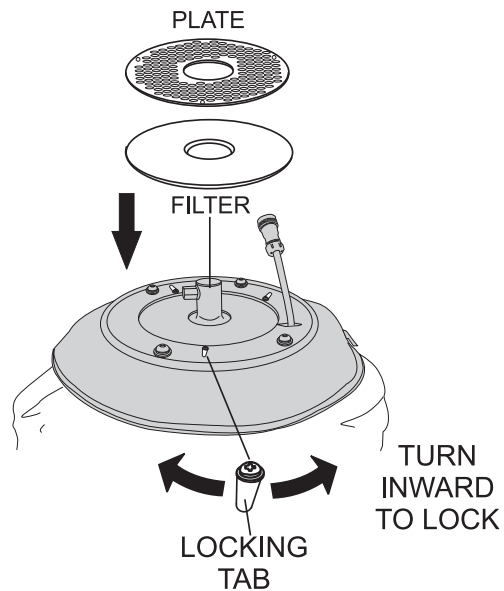

Figure 43. Filter/Plate Install

MAINTENANCE (WIRING DIAGRAM)

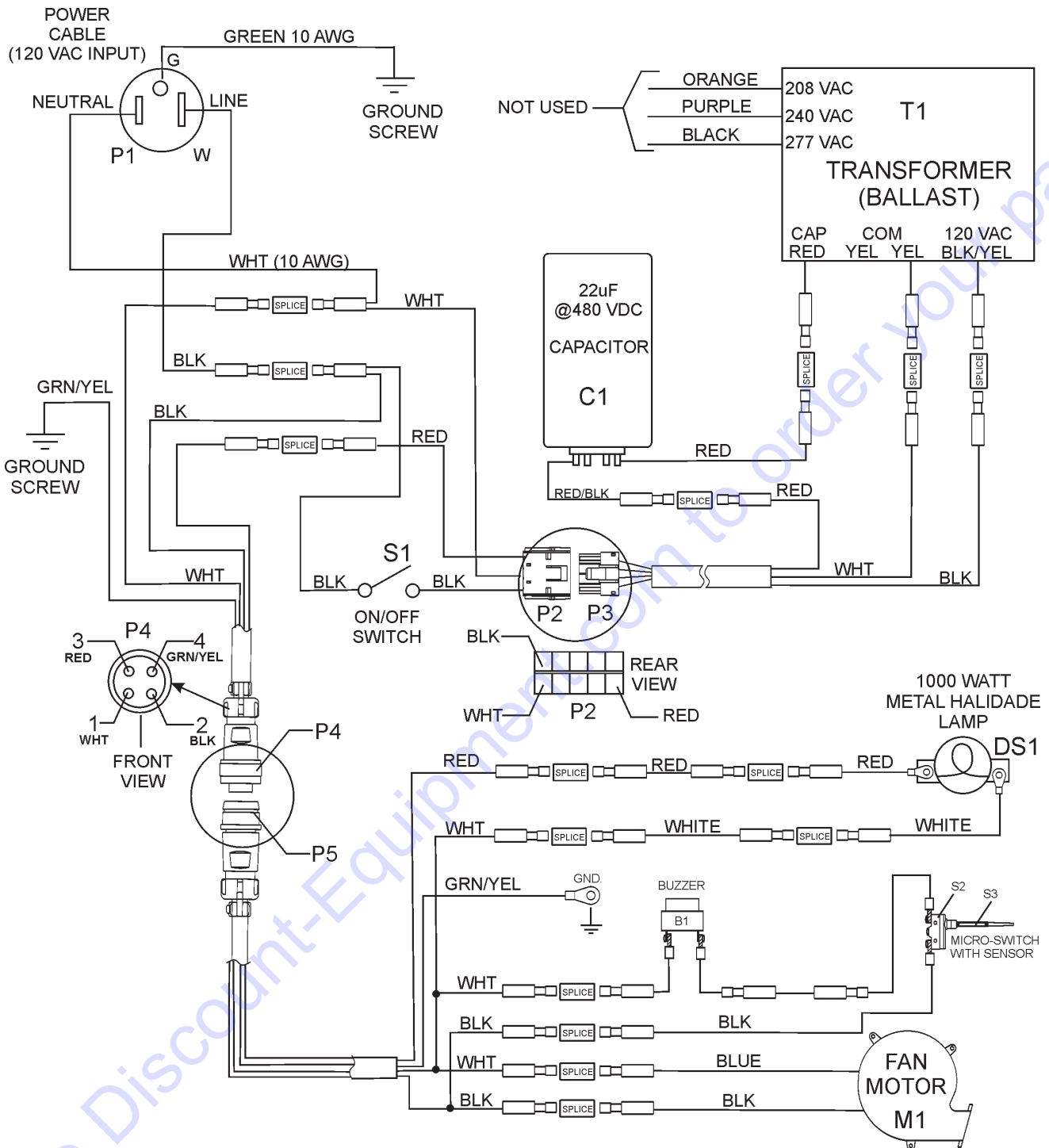

TABLE 3 REFERENCE DESIGNATIONS					
REF. DESC.	DESCRIPTION	PART NUMBER	REF. DESC.	DESCRIPTION	PART NUMBER
P1	AC Power Cable Assy.	A300116300	M1	Fan Motor Assy.	A300033500
P2/P4	Ballast Cable Assy. (From S1)	A300105800	B1	Buzzer Alarm Balloon	E000030100
P3	Ballast Cable Assy. (To Transformer)	A300105600	S2	Micro-Switch	1400150210
P5	Lamp-Fan-Sensor Cable Assy.(Power)	A300105500	S3	Sensor Balloon	1400150410
S1	Single-Pole ON/OFF Switch	A400140600			
DS1	1000 Watt Metal Halide Lamp	E000009800			
C1	22 uf Capacitor @ 480 VDC	A300033800			
T1	Ballast (Transformer)	A300033800			

Figure 44. Wiring Diagram

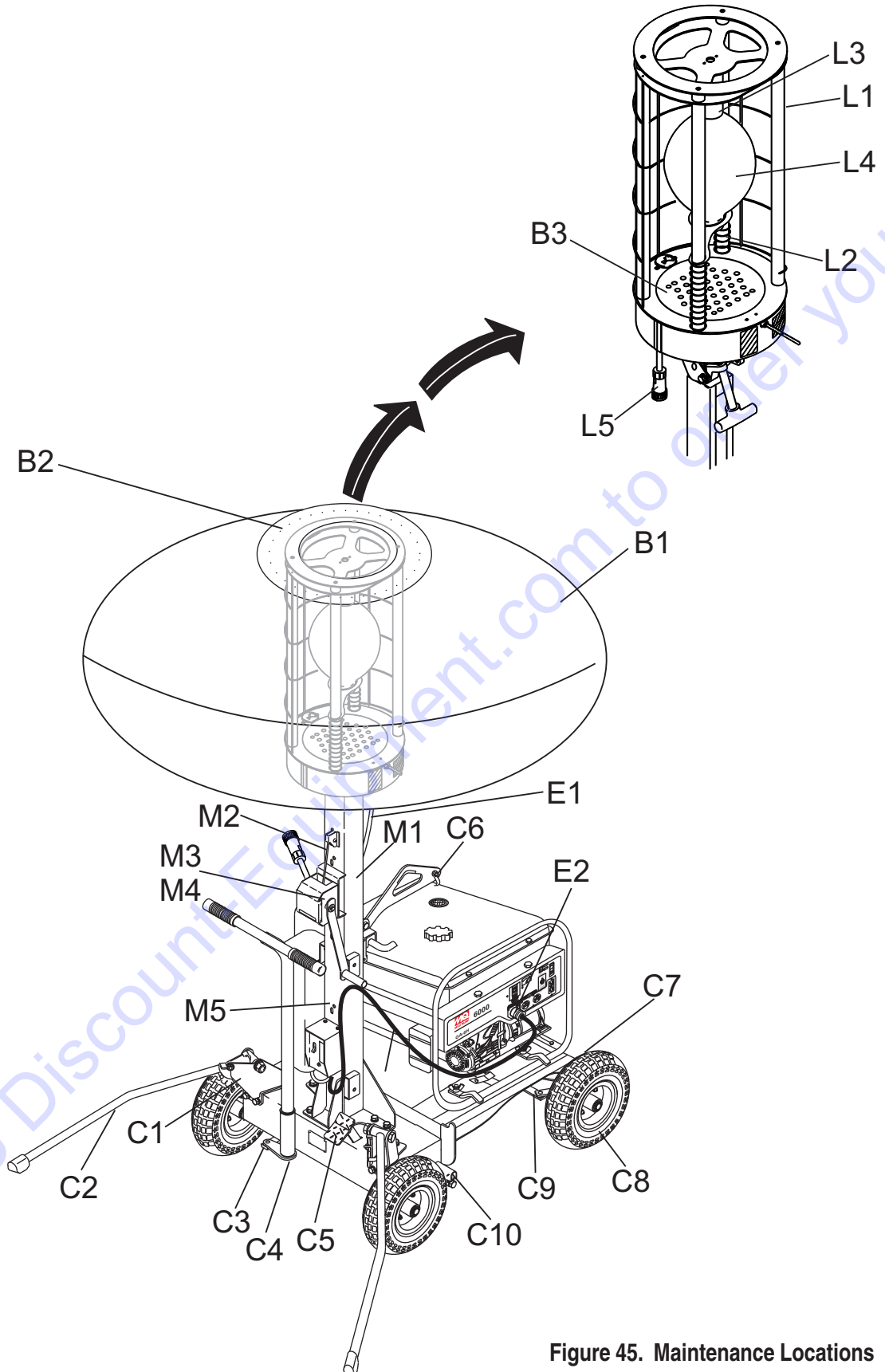

Figure 45. Maintenance Locations

PARTS FINDER

**Search Website
by Part Number**



**Search Manual
Library For Parts
Manual & Lookup Part
Numbers – Purchase
or Request Quote**

Search Manuals

Enter your information to help us find the right parts manual for your machine.

* Brand:

* Model:

* Serial:

* Part Number:

SEARCH

**Can't Find Part or
Manual? Request Help
by Manufacturer,
Model & Description**

Parts Order Form

Please fill in the following information to help us find the right part for your machine.

Manufacturer:	<input type="text"/>
Model:	<input type="text"/>
Description:	<input type="text"/>
Part Number:	<input type="text"/>
Quantity:	<input type="text"/>
Notes:	<input type="text"/>

Submit

Discount-Equipment.com is your online resource for quality parts & equipment.

Florida: **561-964-4949** Outside Florida TOLL FREE: **877-690-3101**

Need parts?

Click on this link: <http://www.discount-equipment.com/category/5443-parts/> and choose one of the options to help get the right parts and equipment you are looking for. Please have the machine model and serial number available in order to help us get you the correct parts. If you don't find the part on the website or on one of the online manuals, please fill out the request form and one of our experienced staff members will get back to you with a quote for the right part that your machine needs.

We sell worldwide for the brands: Genie, Terex, JLG, MultiQuip, Mikasa, Essick, Whiteman, Mayco, Toro Stone, Diamond Products, Generac Magnum, Airman, Haulotte, Barreto, Power Blanket, Nifty Lift, Atlas Copco, Chicago Pneumatic, Allmand, Miller Curber, Skyjack, Lull, Skytrak, Tsurumi, Husquvarna Target, Stow, Wacker, Sakai, Mi-T-M, Sullair, Basic, Dynapac, MBW, Weber, Bartell, Bennar Newman, Haulotte, Ditch Runner, Menegotti, Morrison, Contec, Buddy, Crown, Edco, Wyco, Bomag, Laymor, EZ Trench, Bil-Jax, F.S. Curtis, Gehl Pavers, Heli, Honda, ICS/PowerGrit, IHI, Partner, Imer, Clipper, MMD, Koshin, Rice, CH&E, General Equipment, Amida, Coleman, NAC, Gradall, Square Shooter, Kent, Stanley, Tamco, Toku, Hatz, Kohler, Robin, Wisconsin, Northrock, Oztec, Toker TK, Rol-Air, APT, Wylie, Ingersoll Rand / Doosan, Innovatech, Con X, Ammann, Mecalac, Makinex, Smith Surface Prep, Small Line, Wanco, Yanmar

For a prolonged life cycle an extended quality follow the recommended GloBug service guidelines as referenced in Table 4.

TABLE 4. PERIODIC CHECK AND MAINTENANCE					
FIGURE	PART	CHECK ITEM	SOLUTION		
Lamp	L1	Frame Pipe	Frame pipe skewed?	Replace.	❖
	L2	Lamp Holder	Lamp holder loose?	Tighten or replace.	❖
	L3	Lamp (Base)	Lamp base loose?	Screw in securely.	❖
	L4	Lamp	Defective lamp?	Replace.	❖
	L5	Cable/Connector	Cable disconnected or loose?	Connect securely.	■
Balloon	B1	Balloon (Envelope)	Defective or dirty?	Replace.	❖
	B2	Zipper	Broken?	Replace.	❖
	B3	Fan Motor (Blower)	Working properly?	Repair or replace.	❖
Mast	M1	Mast Sliding Surface	Slides smoothly?	Apply grease.	●
	M2	Wire Rope	Damaged?	Apply grease or replace.	❖
	M3	Wire Rope End	Is wire end damaged (caulking)?	Replace.	❖
	M4	Winch	Defective winch brake ?	Repair or replace.	❖
	M5	Safety Stop	Safety latch defective?	Repair or replace.	▲
Cart	C1	Counter-Weight	Travels smoothly?	Spray grease.	●
	C2	Outriggers	Travels smoothly?	Spray grease.	●
	C3	T-handle and Wheels	Proper movement.	Tighten securely.	■
	C4	Bolt for Handle	Check if bolt is not loose.	Tighten securely.	■
	C5	Brake Pedal	Linkage working correctly.	Check, spray grease	❖
	C5	Brake Pedal	Notch worn-out?	Replace.	❖
	C6	Hanger	Check if the installation is not loose.	Fasten securely.	■
	C7	Front Wheel Pivot	Turns smoothly?	Check, apply grease.	●
	C8	Tires	Tire pressure 35.5 psi (294 kPa)?	Adjust.	❖
	C9	Link for Front Shaft	Linkage moves smoothly?	Spray grease.	●
C10	Brake	Working properly?	Adjust.	❖	
Electric	E1	Power Cable	Defective or worn cable?	Replace.	❖
	E2	Non-load Voltage	Is generator output 125 VAC?	Adjust or replace generator.	●
❖ - Daily Check ■ - Every 20 Hours ● - Every 100 hours ▲ - Every 500 hours					

TROUBLESHOOTING (LAMPS)

Practically all breakdowns can be prevented by proper handling and maintenance inspections, but in the event of a breakdown, please take a remedial action following the diagnosis based on the Lamp Troubleshooting (Table 5) information shown below.

If the problem cannot be remedied, please leave the unit just as it is and consult Discount-equipment.

TABLE 5. LAMP TROUBLESHOOTING

SYMPTOM	POSSIBLE PROBLEM	SOLUTION
Lamp does not light.	Is plug securely connected?	Plug in correctly.
	Are generator and light tower switched on?	Turn on switch.
	Is lamp loose?	Screw lamp securely into socket.
	Is contactor properly connected?	Connect disconnected contactor.
	Are any other electric appliances (other than light tower) plugged into power source?	Unplug all other appliances.
	Is generator voltage normal (non-load voltage - 120 VAC)?	Repair or replace generator.
	Is model of lamp compatible?	Use genuine MQ lamp.
	Is lamp cool enough to light again? (Interval of 20 to 30 minutes is required before turning on lamp again)	Wait for lamp to cool down.
Lamp only lights for a short time.	Is generator voltage normal (non-load voltage - 120 V)?	Repair or replace generator.
	Is ambient temperature too high (more than 104 °F (40 °C))?	Move lamp where there is proper ventilation.
Balloon does not inflate.	Is fan motor (blower) working properly?	Check or repair fan motor (blower).
	Is balloon envelope defective?	Repair or replace balloon envelope.

TROUBLESHOOTING (MAST)

Practically all breakdowns can be prevented by proper handling and maintenance inspections, but in the event of a breakdown, please take a remedial action following the diagnosis based on the Mast Troubleshooting (Table 6) information shown below.

If the problem cannot be remedied, please leave the unit just as it is and consult Discount-equipment.

TABLE 6. MAST TROUBLESHOOTING

SYMPTOM	POSSIBLE PROBLEM	SOLUTION
Mast cannot be raised.	Is cable caught in mast?	Set cable free.
	Is end of wire rope disconnected from winch?	Connect wire rope to winch.
	Does surface of mast slide smoothly?	Apply grease to sliding surface of mast.
Mast keeps coming down.	Is winch latch functioning properly?	Replace part if not functioning properly.
	Is dram shaft loose?	Tighten dram shaft and check its operation.
The mast cannot be lowered.	Does surface of mast slide smoothly?	Apply grease to sliding surface of mast.
	Is brake disk of winch held tight?	Holding winch handle securely, remove the latch and lower mast slowly (Repair).
	Does safety stopper work correctly?	Winch up mast a little and lower mast by putting a load on it (Repair).

EXPLANATION OF CODES IN THE REMARKS COLUMN

The following section explains the different symbols and remarks used in the Parts section of this manual. Use the help numbers found on the back page of the manual if there are any questions.

NOTICE

The contents and part numbers listed in the parts section are subject to change **without notice**. Multiquip does not guarantee the availability of the parts listed.

SAMPLE PARTS LIST

NO.	PART NO.	PART NAME	QTY.	REMARKS
1	12345	BOLT.....	1	INCLUDES ITEMS W/%
2%		WASHER, 1/4 IN.....		NOT SOLD SEPARATELY
2%	12347	WASHER, 3/8 IN....	1	MQ-45T ONLY
3	12348	HOSE	A/R	MAKE LOCALLY
4	12349	BEARING	1	S/N 2345B AND ABOVE

NO. Column

Unique Symbols — All items with same unique symbol

(@, #, +, %, or >) in the number column belong to the same assembly or kit, which is indicated by a note in the “Remarks” column.

Duplicate Item Numbers — Duplicate numbers indicate multiple part numbers, which are in effect for the same general item, such as different size saw blade guards in use or a part that has been updated on newer versions of the same machine.

NOTICE

When ordering a part that has more than one item number listed, check the remarks column for help in determining the proper part to order.

PART NO. Column

Numbers Used — Part numbers can be indicated by a number, a blank entry, or TBD.

TBD (To Be Determined) is generally used to show a part that has not been assigned a formal part number at the time of publication.

A blank entry generally indicates that the item is not sold separately or is not sold by Multiquip. Other entries will be clarified in the “Remarks” Column.

QTY. Column

Numbers Used — Item quantity can be indicated by a number, a blank entry, or A/R.

A/R (As Required) is generally used for hoses or other parts that are sold in bulk and cut to length.

A blank entry generally indicates that the item is not sold separately. Other entries will be clarified in the “Remarks” Column.

REMARKS Column

Some of the most common notes found in the “Remarks” Column are listed below. Other additional notes needed to describe the item can also be shown.

Assembly/Kit — All items on the parts list with the same unique symbol will be included when this item is purchased.

Indicated by:

“INCLUDES ITEMS W/(unique symbol)”

Serial Number Break — Used to list an effective serial number range where a particular part is used.

Indicated by:

“S/N XXXXX AND BELOW”

“S/N XXXX AND ABOVE”

“S/N XXXX TO S/N XXX”

Specific Model Number Use — Indicates that the part is used only with the specific model number or model number variant listed. It can also be used to show a part is NOT used on a specific model or model number variant.

Indicated by:

“XXXXX ONLY”

“NOT USED ON XXXX”

“Make/Obtain Locally” — Indicates that the part can be purchased at any hardware shop or made out of available items. Examples include battery cables, shims, and certain washers and nuts.

“Not Sold Separately” — Indicates that an item cannot be purchased as a separate item and is either part of an assembly/kit that can be purchased, or is not available for sale through Multiquip.

SUGGESTED SPARE PARTS

GloBug LIGHTING SYSTEM 1 TO 3 UNITS

<u>Qty.</u>	<u>P/N</u>	<u>Description</u>
2	E000009800	BULB
2	A300033800	BALLAST/TRANSFORMER
2	A300038400	CAPACITOR, 24 μ F @ 480 VDC
2	A100031301	BALLOON CLOTH
3	A400038300	FILTER 200 (AIR)

Go to Discount-Equipment.com to order your parts

NAMEPLATE AND DECALS

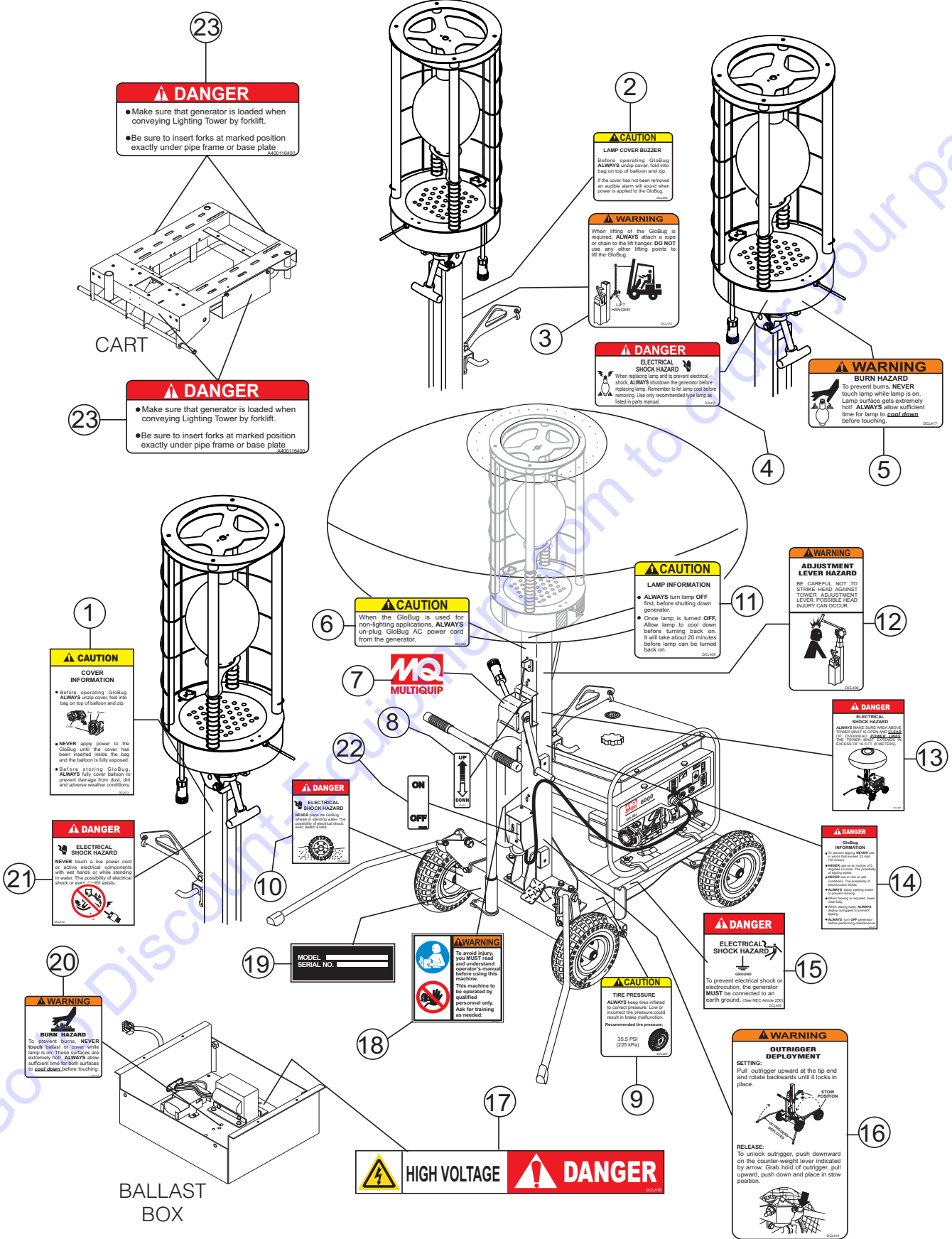

23

⚠ DANGER

- Make sure that generator is loaded when conveying Lighting Tower by forklift.
- Be sure to insert forks at marked position exactly under pipe frame or base plate.

23

⚠ DANGER

- Make sure that generator is loaded when conveying Lighting Tower by forklift.
- Be sure to insert forks at marked position exactly under pipe frame or base plate.

2

⚠ CAUTION

LAMP COVER BUZZER

Before operating GloBug ALWAYS wear cover. Seal and bag on top of ballast and zip. If the cover has not been removed an audible alarm will sound when power is applied to the GloBug.

3

⚠ WARNING

When lifting of the GloBug is required, ALWAYS attach a rope or chain to the lift hanger. DO NOT use any other lifting points to lift the GloBug.

4

⚠ DANGER

ELECTRICAL SHOCK HAZARD

When replacing lamps and to prevent electrical shock, ALWAYS shut down the generator before replacing lamps. Remember to set lamp cool before removing. Use only recommended type lamp as listed in parts manual.

5

⚠ WARNING

BURN HAZARD

To prevent burns, NEVER touch lamp while lamp is on. Lamp surface gets extremely hot! ALWAYS allow sufficient time for lamp to cool down before touching.

1

⚠ CAUTION

COVER INFORMATION

- Before operating GloBug ALWAYS snap cover, top into bag on top of ballast and zip.
- NEVER apply power to the GloBug until the cover has been fastened inside the bag and the ballast is fully exposed.
- Before storing GloBug, ALWAYS fully cover ballast to prevent damage from dust, oil and adverse weather conditions.

6

⚠ CAUTION

When the GloBug is used for non-lighting applications, ALWAYS unplug GloBug AC power cord from the generator.

11

⚠ CAUTION

LAMP INFORMATION

- ALWAYS turn lamp OFF first, before shutting down generator.
- Once lamp is turned OFF, Allow lamp to cool down before turning back on. It will take about 20 minutes before lamp can be turned back on.

12

⚠ WARNING

ADJUSTMENT LEVER HAZARD

BE CAREFUL NOT TO STRIKE HEAD AGAINST TOWER. ADJUSTMENT LEVER, POSSIBLE HEAD INJURY CAN OCCUR.

21

⚠ DANGER

ELECTRICAL SHOCK HAZARD

NEVER touch a live power cord or wire electrical components with wet hands or while standing in water. The possibility of electrical shock or even DEATH exists.

7

⚠ DANGER

ELECTRICAL SHOCK HAZARD

NEVER plug the GloBug into a receptacle until the receptacle is inspected for any electrical damage. (See Model Serial Manual for more details.)

13

⚠ DANGER

ELECTRICAL SHOCK HAZARD

Always wear safety glasses when working on electrical components. ALWAYS use proper safety procedures when working on electrical components. ALWAYS use proper safety procedures when working on electrical components.

14

⚠ DANGER

ELECTRICAL SHOCK HAZARD

Always wear safety glasses when working on electrical components. ALWAYS use proper safety procedures when working on electrical components. ALWAYS use proper safety procedures when working on electrical components.

15

⚠ DANGER

ELECTRICAL SHOCK HAZARD

To prevent electrical shock or electrocution, the generator MUST be connected to an earth ground. (See NEC Article 250)

9

⚠ CAUTION

TIRE PRESSURE

ALWAYS keep tires inflated to correct pressure. Low or incorrect tire pressure could result in faster wear. Recommended tire pressure: 35.5 PSI (225 kPa)

16

⚠ WARNING

OUTRIGGER DEPLOYMENT

SETTING: Pull outrigger upward at the tip end and rotate backwards until it locks in place.

RELEASE: To unlock outrigger, push downward on the counter-weight lever indicated by arrow. Grab hold of outrigger, pull upward, push down and place in slow position.

19

MODEL SERIAL NO.

⚠ WARNING

To avoid injury, you MUST read and understand operator's manual before using this machine. This machine to be operated by qualified personnel only. Ask for training as needed.

20

⚠ WARNING

BURN HAZARD

To prevent burns, NEVER touch ballast or cover while lamp is on. These surfaces are extremely hot! ALWAYS allow sufficient time for ballast to cool down before touching.

⚡ HIGH VOLTAGE **⚠ DANGER**

BALLAST BOX

NAMEPLATE AND DECALS

NAMEPLATE AND DECALS.

<u>NO.</u>	<u>PART NO.</u>	<u>PART NAME</u>	<u>QTY.</u>	<u>REMARKS</u>
1	DCL413	DECAL; CAUTION COVER INFORMATION	1	
2	DCL404	DECAL; CAUTION LAMP COVER BUZZER	1	
3	DCL412	DECAL; WARNING, LIFT HANGER	1	
4	DCL416	DECAL; DANGER, ELECTRICAL SHOCK HAZ.	1	
5	DCL417	DECAL; WARNING, BURN HAZARD (LAMP)	1	
6	DCL402	DECAL; CAUTION, REMOVE POWER CORD	1	
7	DCL428	DECAL; MQ LOGO	1	
8	DCL401	DECAL; WINCH UP/DOWN	1	
9	DCL407	DECAL; CAUTION, TIRE PRESSURE	1	
10	DCL400	DECAL; DANGER, ELECTRICAL SHOCK (TIRES)	1	
11	DCL409	DECAL; CAUTION, LAMP INFORMATION	1	
12	DCL406	DECAL; WARNING, ADJ. LEVER HAZARD	1	
13	DCL403	DECAL; DANGER ELECTRIC SHOCK (GLOBUG)	1	
14	DCL411	DECAL; DANGER, GLOBUG INFORMATION	1	
15	DCL405	DECAL; DANGER, ELECTRICAL SHOCK (GND.)	1	
16	DCL414	DECAL; WARNING, OUTRIGGER DEPLOYMENT	1	
17	DCL418	DECAL; DANGER, HIGH VOLTAGE	1	
18	35137	DECAL; WARNING, READ MANUAL	1	
19		NAMEPLATE	1	
20	DCL415	DECAL; BURN HAZARD (BALLAST)	1	
21	DCL410	DECAL; DANGER, ELECTRICAL SHOCK (CORDS)	1	
22	DCL408	DECAL; ON/OFF	1	
23	A400116400	DECAL; FORKLIFT ALIGNMENT	4	

Go to Discount-Equipment.com to order your parts

T-HANDLE ASSY.

T-HANDLE ASSY.

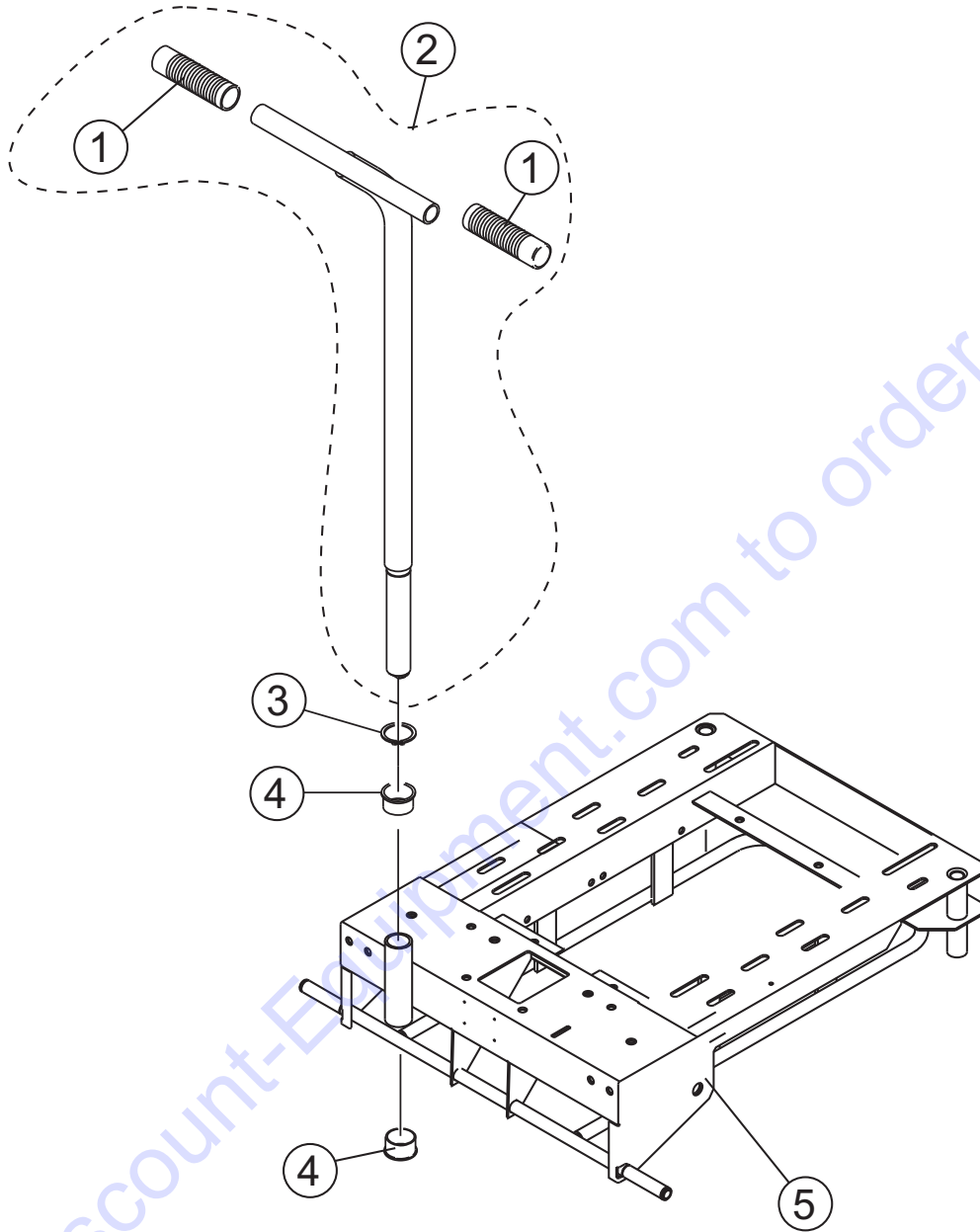

T-HANDLE ASSY.

T-HANDLE ASSY.

<u>NO.</u>	<u>PART NO.</u>	<u>PART NAME</u>	<u>QTY.</u>	<u>REMARKS</u>
1*	1102700130	HANDLE GRIP	2	
2	A200023001	HANDLE	2	INCLUDES ITEM W/*
3	0040730000	SNAP RING (30)	1	
4	1503300130	SLEEVE BEARING (30DX34DX20)	2	
5	A100018905	BASE PLATE	1	

Go to Discount-Equipment.com to order your parts

STEERING ASSY.

STEERING ASSY.

<u>NO.</u>	<u>PART NO.</u>	<u>PART NAME</u>	<u>QTY.</u>	<u>REMARKS</u>
2	A200022903	FRONT SHAFT (L)	1	
3	A200022803	FRONT SHAFT (R)	1	
4	2001200313	BRAKE PEDAL	1	
5	2071214010	BRAKE	2	
6	2071213211	BRAKE SHAFT	1	
7	1041000131	SPRING (BRAKE)	1	
8	0010308030	BOLT (M8x30) SUS	1	
9	0033108000	NUT (M8)	2	
10	0043108000	WASHER (M8)	5	
11	0013212075	BOLT (M12x75)	1	
12	1521120131	BOLT (M12x75) LEFT SCREW	1	
13	1503180130	SLEEVE BEARING (18Dx20Dx20)	2	
14	A400055501	LINK (FRONT SHAFT)	1	
15	0040720000	SNAP RING (20)	8	
20	A300090600	LINK, HANDLE	1	
21	0043112000	WASHER (M12)	1	
22	1504120130	WASHER (12.2Dx18Dx0.5T)	6	
23	0033208000	SELF LOCK NUT (M8)	1	
24	0030808000	PUSH NUT (8)	3	
25	0013512025	BOLT & WASHER (M12x25)	1	
26	0043112041	WASHER (12Dx40Dx3.2T)	1	
27	A400055401	LINK (STEERING)	1	
28	E000014500	TIRE ASSY (4.10/3.50-5)	4	
46	A400055101	SPACER	1	
47	E000031200	WASHER, (20Dx36Dx1.5)	2	

OUTRIGGER ASSY.

OUTRIGGER ASSY.

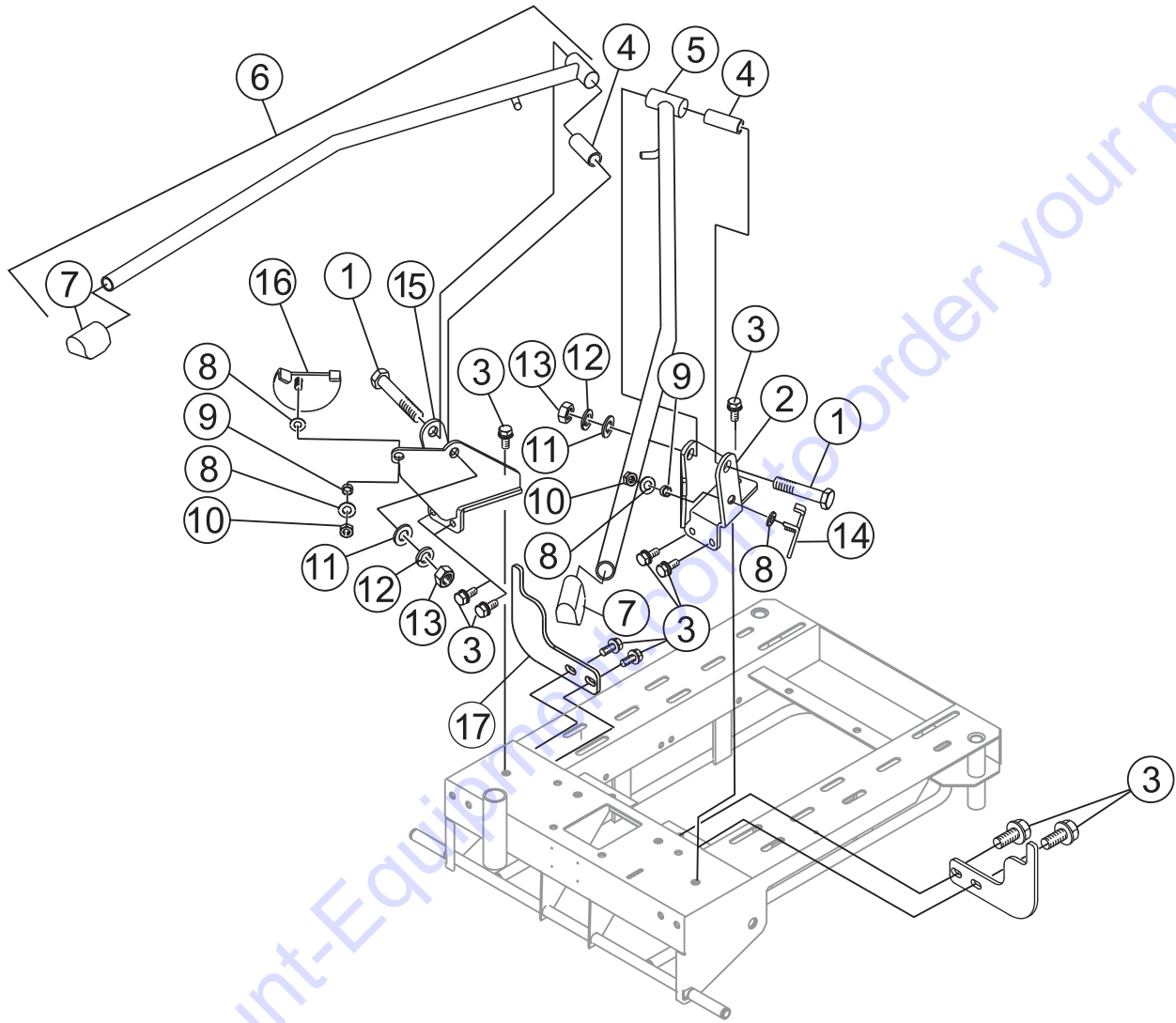

OUTRIGGER ASSY.

OUTRIGGER ASSY.

<u>NO.</u>	<u>PART NO.</u>	<u>PART NAME</u>	<u>QTY.</u>	<u>REMARKS</u>
1	0013116090	BOLT (M16x90)	2	
2	A100011601	BRACKET (OUT,R) R	1	
3	0013510025	BOLT & WASHER (M10x25)	10	
4	1501160111	SPACER (OUT,R)	2	
5	A200015303	OUTRIGGER R	1	INCLUDES ITEM W/*
6	A200015203	OUTRIGGER L	1	INCLUDES ITEM W/*
7*	1641000330	RUBBER FOOT	2	
8	0043110000	WASHER (M10)	4	
9	1501100430	SPACER (10.2dx13.8Dx6.5L)	2	
10	0033210000	SELF LOCK NUT (M10)	2	
11	0043116000	WASHER (M16)	2	
12	0043216000	WASHER, SPRING (M16)	2	
13	0033116000	NUT (M16)	2	
14	2031321113	WEIGHT (OUT,R) R	1	
15	A100011501	BRACKET (OUT,R) L	1	
16	2031320213	WEIGHT (OUT,R) L	1	
17	A400033402	CATCHER (OUTRIGGER)	2	

Go to Discount-Equipment.com to order your parts

MAST ADAPTER ASSY.

MAST ADAPTER ASSY.

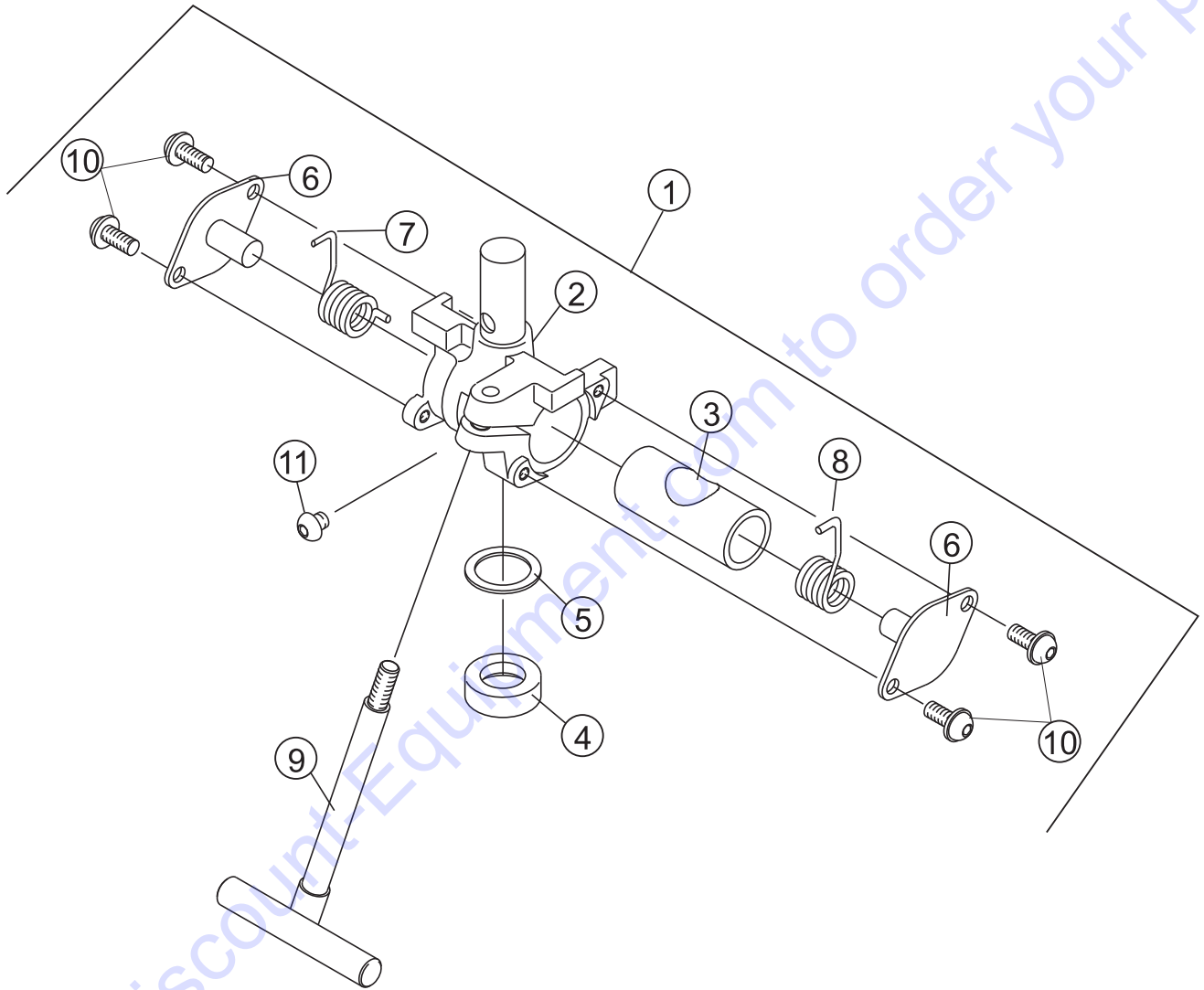

MAST ADAPTER ASSY.

MAST ADAPTER ASSY.

<u>NO.</u>	<u>PART NO.</u>	<u>PART NAME</u>	<u>QTY.</u>	<u>REMARKS</u>
1	2202390100	STAND ASSY.	1	INCLUDES ITEMS W/*
2*	2202390112	STAND	1	
3*	2202500130	SHAFT (STAND)	1	
4	2202500230	SPACER (STAND)	1	
5	1502280130	WASHER	1	
6*	2202520110	COVER (SPRING)	2	
7*	1043002030	SPRING (STAND) L	1	
8*	1043002130	SPRING (STAND) R	1	
9	A400038801	GRIP SHAFT	1	
10*	0014808025	BUTTON BOLT & WASHER (M8 X 15)	4	
11	0014708010	BUTTON BOLT (M8 X10)	1	

Go to Discount-Equipment.com to order your parts

MAIN MAST ASSY.

MAIN MAST ASSY.

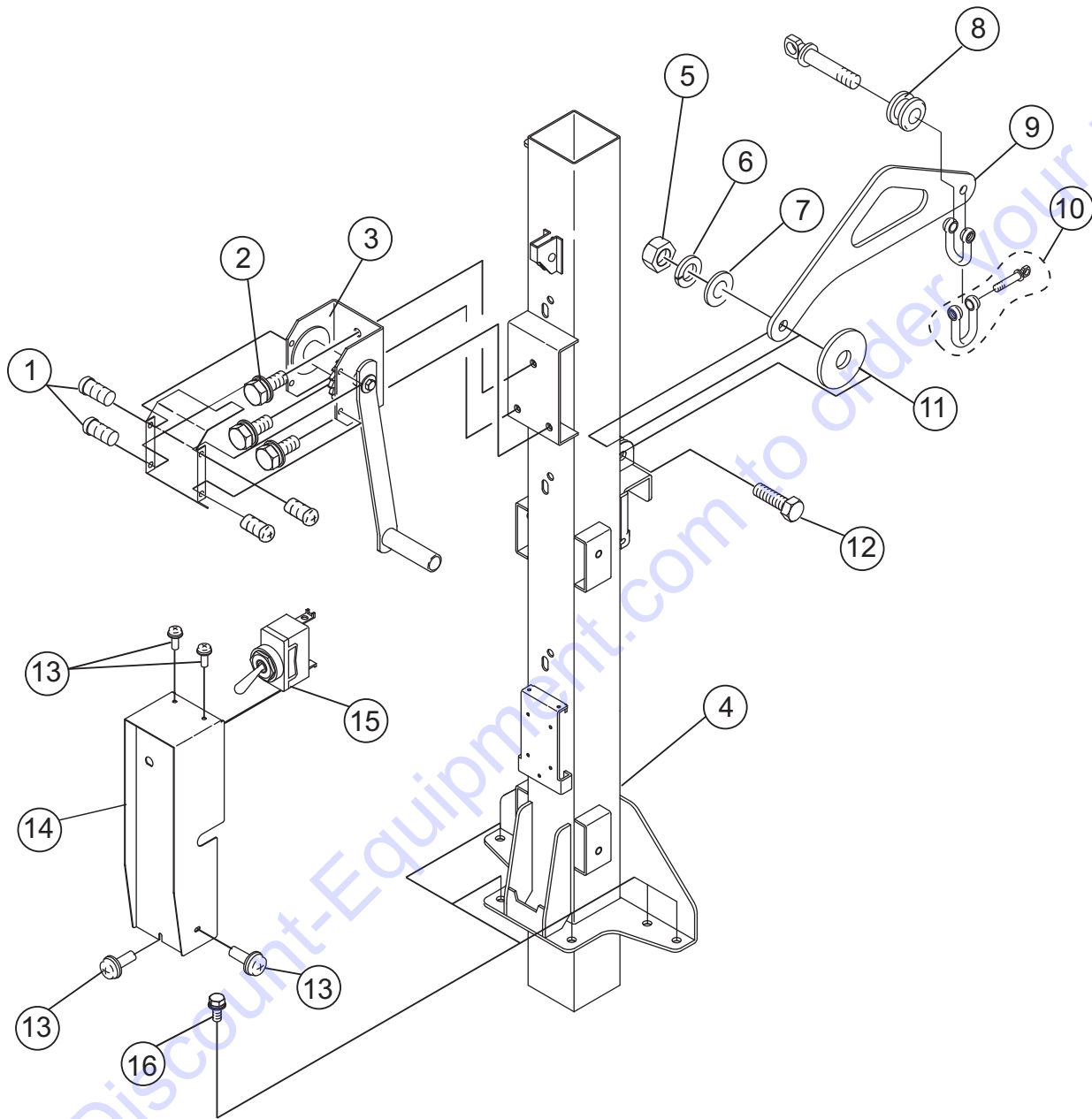

MAIN MAST ASSY.

MAIN MAST ASSY.

<u>NO.</u>	<u>PART NO.</u>	<u>PART NAME</u>	<u>QTY.</u>	<u>REMARKS</u>
1	0020105008	SCREW & WASHER, M5X8	4	
2	0013510025	BOLT & WASHER (M10x25)	3	
3	1011000701	WINCH HM-G103	1	
4	A100028105	FIRST MAST	1	
5	0033112000	NUT (M12)	1	
6	0043212000	WASHER, LOCK (M12)	1	
7	0043112000	WASHER (M12)	1	
8	1642001430	GROMMET	1	
9	1052001710	HANGER	1	
10	1711080130	SHACKLE, W/BOLT	2	
11	0043112041	WASHER (12dx40Dx3.2t)	1	
12	0013112040	BOLT (M12x40)	1	
13	0023305015	SCREW & WASHER (M5x15)	5	
14	A200039400	SWITCH COVER	1	FOR FIRST MAST
15	A300117800	SWITCH ASSY.	1	
16	0013512025	BOLT & WASHER (M12x25)	6	

Go to Discount-Equipment.com to order your parts

WINCH ASSY.

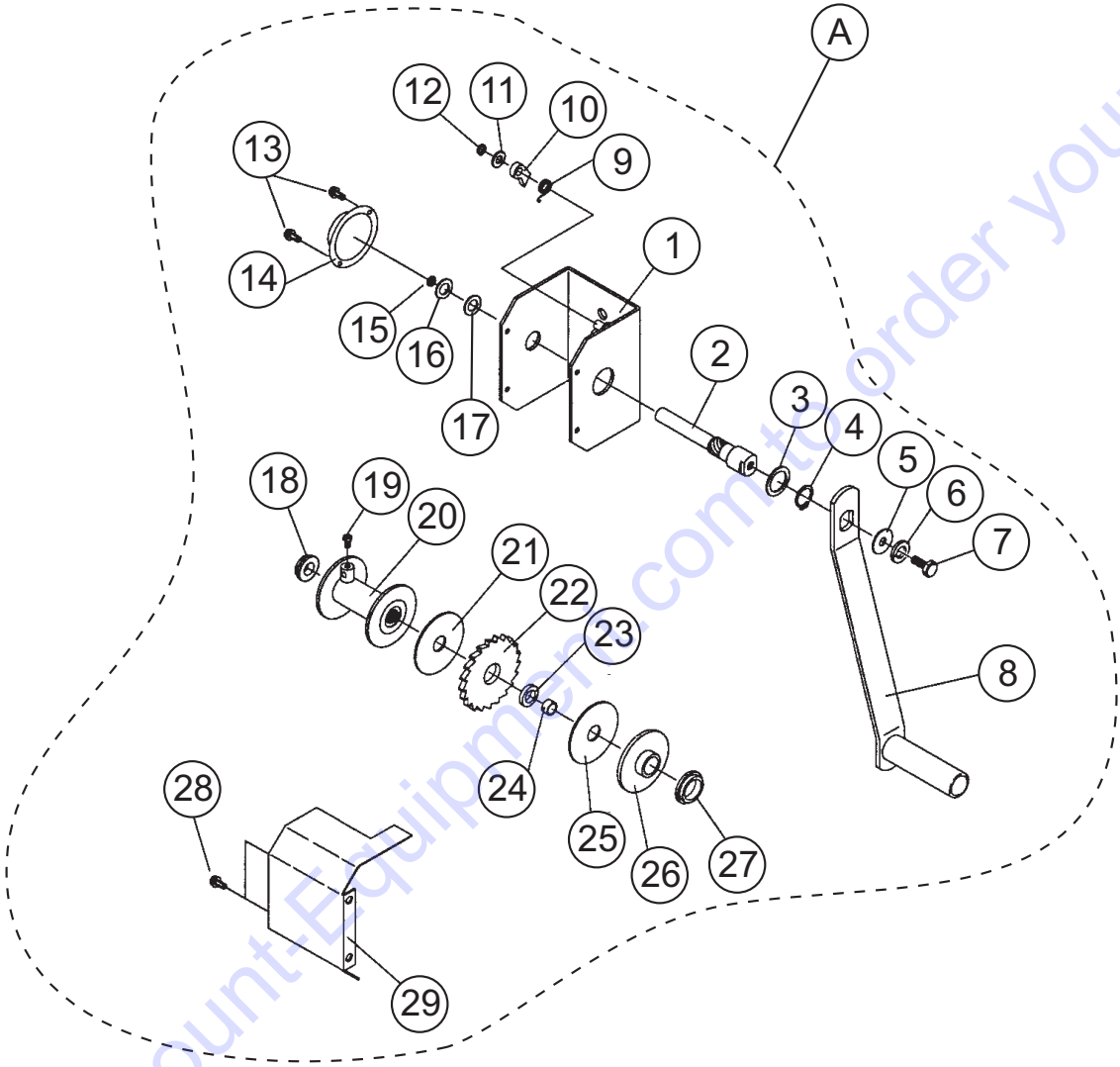

WINCH ASSY.

WINCH ASSY.

<u>NO.</u>	<u>PART NO.</u>	<u>PART NAME</u>	<u>QTY.</u>	<u>REMARKS</u>
A	1011000701	WINCH HM-G103	1	INCLUDES ITEMS W/*
1*	E000049800	FRAME	1	
2*	E000049900	DRUM SHAFT	1	
3*	E000050000	WASHER	1	
4*	E000050100	SNAP RING	1	
5*	1011001460	WASHER	1	
6*	030208200	WASHER, LOCK M8	1	
7*	0010108015	BOLT, M8X15	1	
8*	1011001361	HANDLE	1	
9*	1011000460	SPRING	1	
10*	1011000360	RACHET	1	
11*	0043108000	WASHER, M8	1	
12*	0040707000	SNAP RING, 7	1	
13*	0020403006	SCREW, M3X6 TRUSS HEAD	2	
14*	E000050200	COVER	1	
15*	E000050300	SNAP RING	1	
16*	E000050400	WASHER	1	
17*	E000051100	WAVE WASHER	1	
18*	E000050500	PLASTIC WASHER 1	1	
19*	0001050410	BOLT, M4X10	1	
20*	1011000760	DRUM PIPE	1	
21*	E000050600	LINING 2	1	
22*	1011000960	RATCHET GEAR	1	
23*	E000050700	COLLAR 1	1	
24*	E000050800	COLLAR 2	1	
25*	1011000860	LINING 1	1	
26*	E000050900	BACK PLATE	1	
27*	E000051000	PLASTIC WASHER 2	1	
28*	1011000260	COVER	1	
29*	0020105008	SCREW & WASHER, M5X8	4	

MAST SECTION ASSY.

MAST SECTION ASSY.

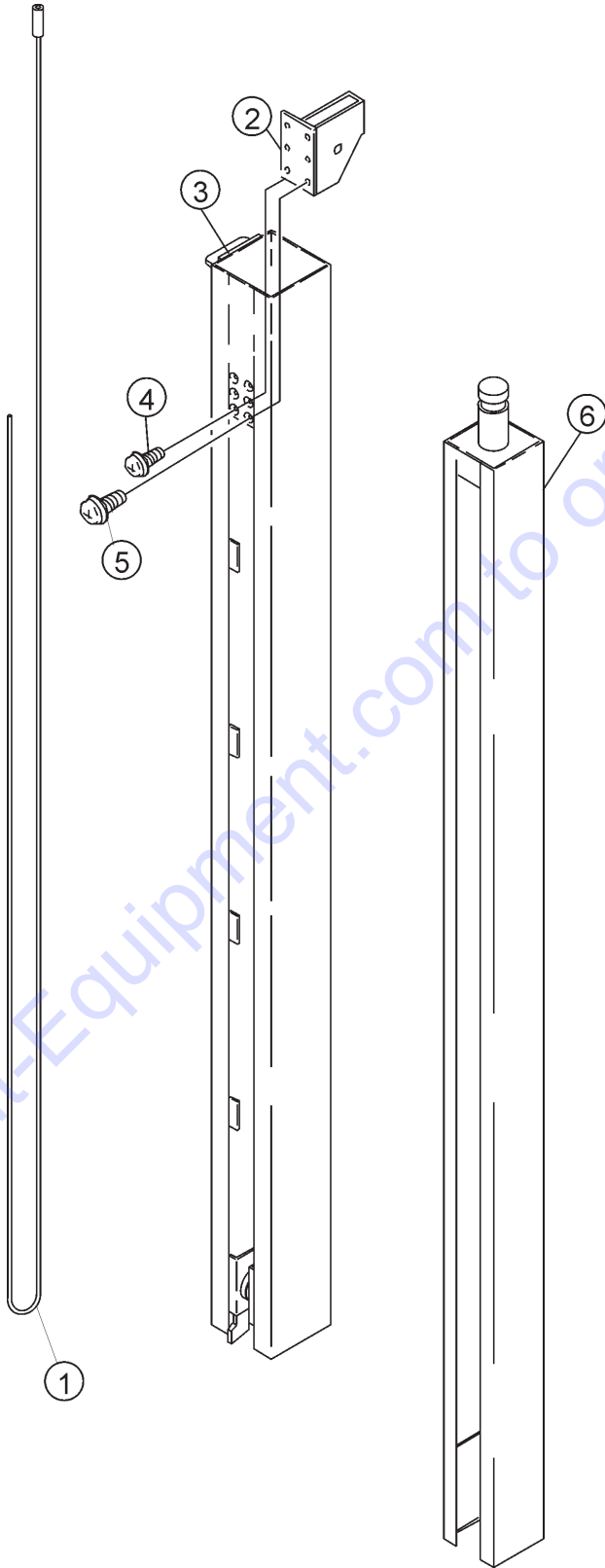

MAST SECTION ASSY.

MAST SECTION ASSY.

<u>NO.</u>	<u>PART NO.</u>	<u>PART NAME</u>	<u>QTY.</u>	<u>REMARKS</u>
1	1031040113	WIRE (4Dx4800L)	1	
2	2002262010	BRACKET (PULLEY)	1	MAST SECTION 2
3	A200027200	SECOND MAST	1	
4	0023204010	SCREW (M4x10)	3	
5	0023204006	SCREW (M4x6)	3	
6	A200027301	THIRD MAST	1	

Go to Discount-Equipment.com to order your parts

BASEPLATE COVER ASSY.

BASEPLATE COVER ASSY.

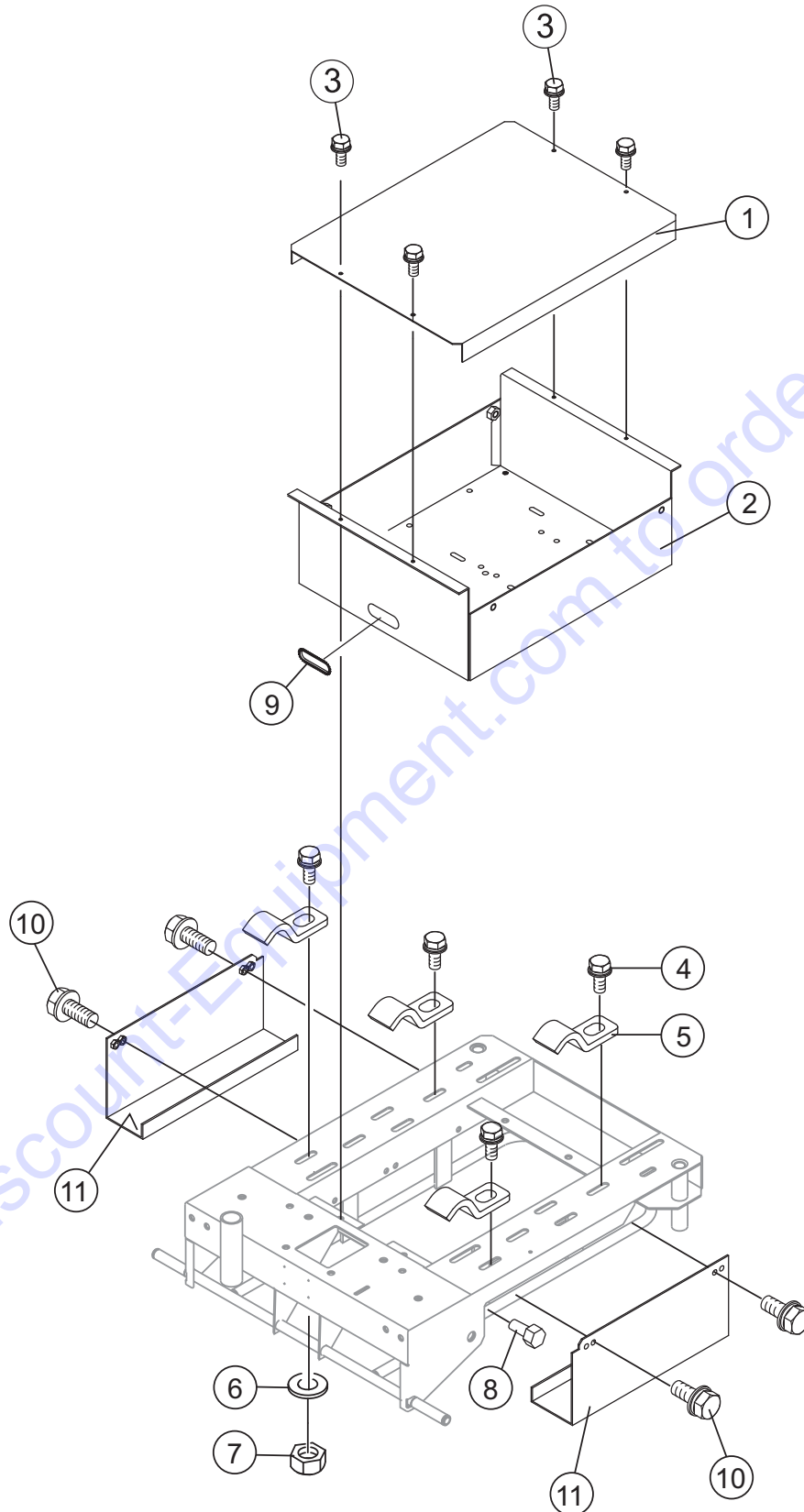

BASEPLATE COVER ASSY.

BASEPLATE COVER ASSY.

<u>NO.</u>	<u>PART NO.</u>	<u>PART NAME</u>	<u>QTY.</u>	<u>REMARKS</u>
1	A100030101	COVER (BALLAST)	1	
2	A100030203	BOX (BALLAST) CP	1	
3	0013510025	BOLT & WASHER (M10x25)	4	
4	0013512025	BOLT & WASHER (M12x25)	4	
5	A400041101	STOPPER	4	
6	0043112000	WASHER (M12)	4	
7	0033112000	NUT (M12)	4	
8	0013106010	BOLT (M6x10)	1	
9	E000032100	FREE BUSH	1	
10	0013508015	BOLT & WASHER (M8x25)	4	
11	A300087403	SIDE GUARD	2	

Go to Discount-Equipment.com to order your parts

BALLAST ASSY.

BALLAST ASSY.

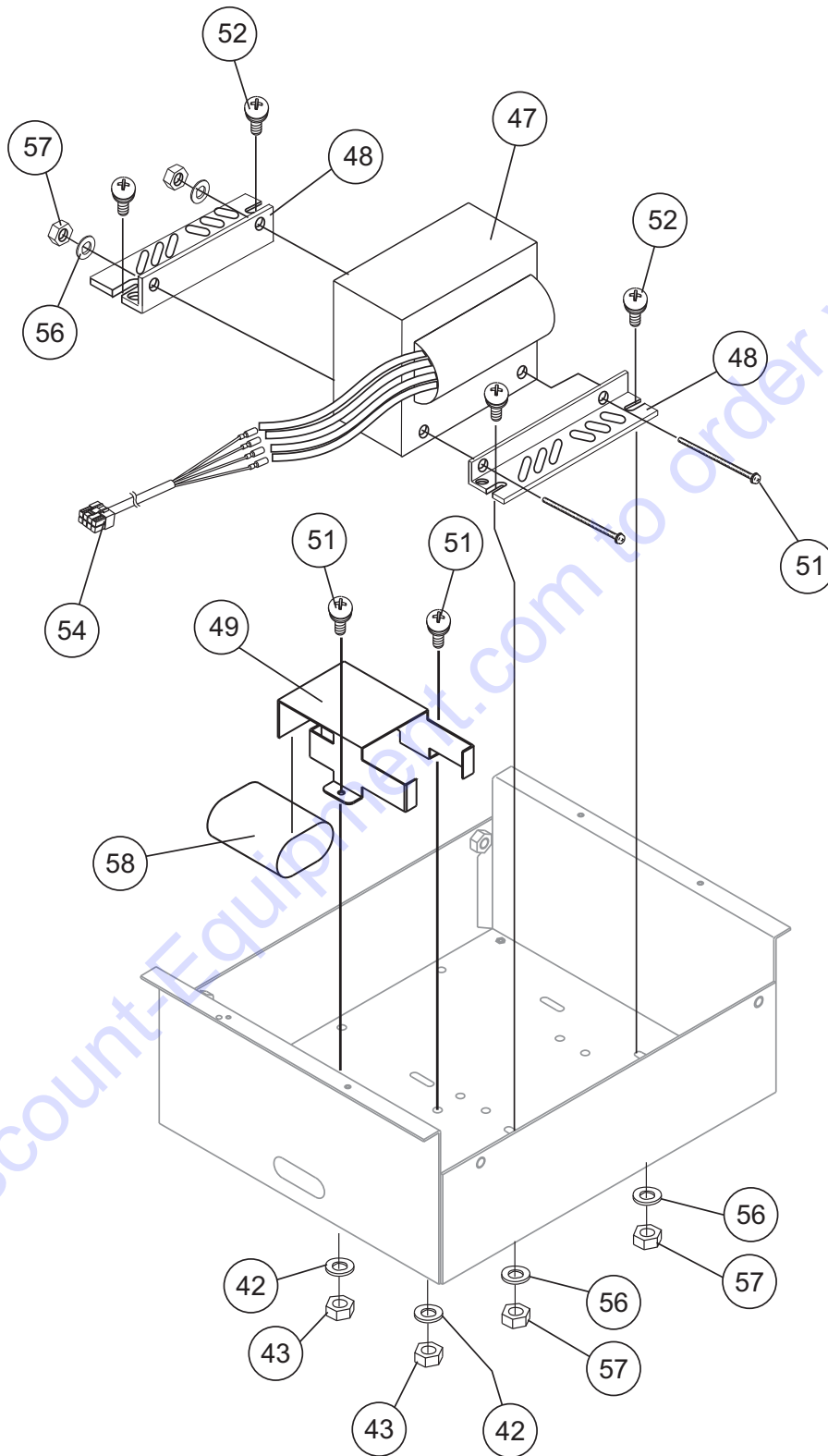

BALLAST ASSY.

BALLAST ASSY.

<u>NO.</u>	<u>PART NO.</u>	<u>PART NAME</u>	<u>QTY.</u>	<u>REMARKS</u>
42	GB0043104000	WASHER, (M4)	4	
43	0033104000	NUT, (M4)	7	
47	A300033800	BALLAST, CP	1	
48	E000056800	BALLAST HOLDER	2	
49	A200018200	HOLDER	1	
50	0023305015	SCREW & WASHER, (M5x15)	2	
51	0023305090	SCREW & WASHER, (M5x90)	2	
52	0013505015	BOLT & WASHER, (5x15)	2	
54	A300105600	CABLE, BALLAST CP	1	
56	0043105000	WASHER, (M5)	6	
57	0033105000	NUT, (M5)	6	
58	A300038400	CAPACITOR, 24 F @480 VDC	1	

Go to Discount-Equipment.com to order your parts

FAN BLOWER/LAMP BASE ASSY.

FAN BLOWER/LAMP BASE ASSY.

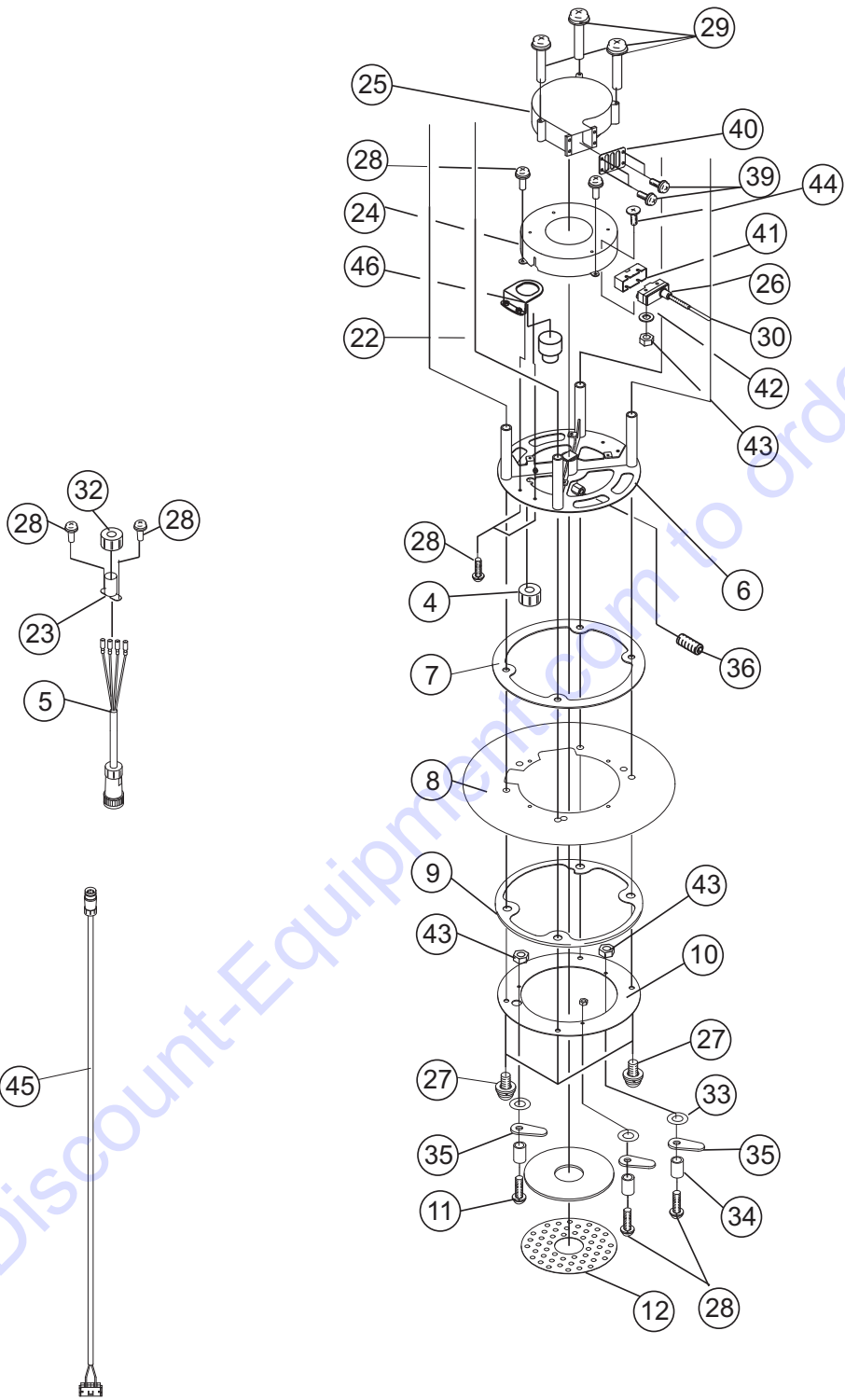

FAN BLOWER/LAMP BASE ASSY.

FAN BLOWER/LAMP BASE ASSY.

<u>NO.</u>	<u>PART NO.</u>	<u>PART NAME</u>	<u>QTY.</u>	<u>REMARKS</u>
4	E000045000	CABLE CLAMP	1	
5	A300105500	CABLE 1 (BALLOON) CP	1	
6	A100013302	FLANGE	1	
7	2204500130	SEAL (NORMAL)	1	
8	1800001100	SHEET (BOTTOM)	1	
9	2204500230	PACKING	1	
10	A300034400	PLATE (BOTTOM)	1	
11	A400038300	FILTER 200 (AIR)30	1	
12	A200018000	PLATE (AIR)	1	
22	E000030100	BUZZER	1	
23	A400038901	COVER, WIRE	1	
24	A200017702	VESSEL	1	
25	A300033500	FAN MOTOR CP	1	
26	1400150210	MICRO SWITCH	1	
27	0014808025	BUTTON SCREW & WASHER (M8x25)	8	
28	0024304008	SCREW (M4x8)	9	
29	0023305060	SCREW & WASHER (M5x60)	3	
30	1400150410	MICRO SWITCH CAP (SENSOR)	1	
32	E000011900	COVER	1	
33	E000009701	WAVE WASHER (M5)	3	
34	E000010301	SPACER	3	
35	A400030700	STOPPER (FILTER) CP	3	
36	0021710025	SET SCREW (M10x25)	1	
39	0023105008	SCREW (M5x8)	4	
40	A400037400	GUARD (FAN)	1	
41	1400150300	MICRO SWITCH COVER	1	
42	0043104000	WASHER (M4)	4	
43	0033104000	NUT (M4)	5	
44	0023204030	SCREW (M4x30)	2	
45	A300105800	CABLE 2 (BALLOON) CP	1	
46	A400038601	BRACKET, BUZZER	1	

BALLOON/LAMP GUARD ASSY.

BALLOON/LAMP GUARD ASSY.

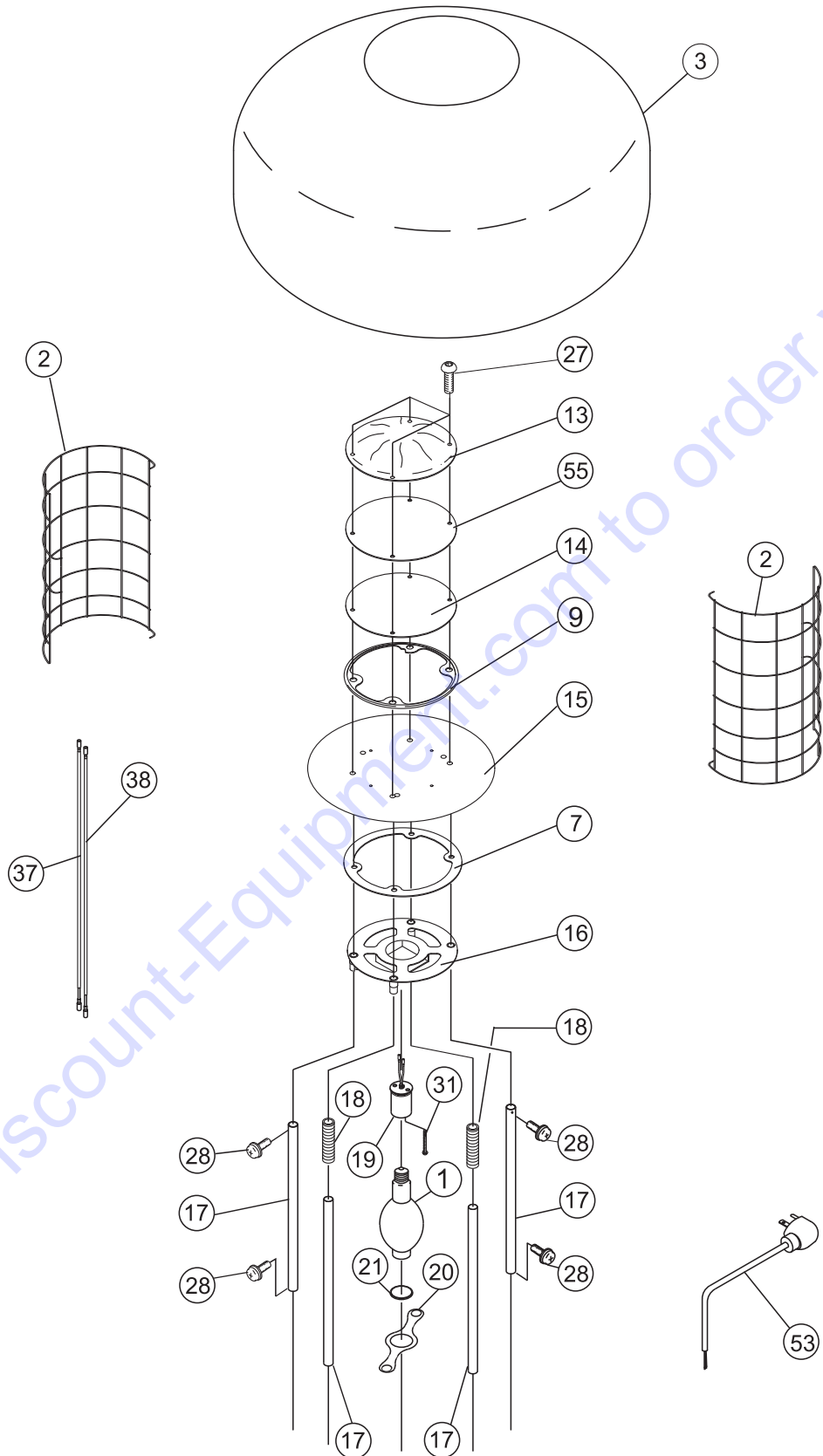

BALLOON/LAMP GUARD ASSY.

BALLOON/LAMP GUARD ASSY.

<u>NO.</u>	<u>PART NO.</u>	<u>PART NAME</u>	<u>QTY.</u>	<u>REMARKS</u>
1	E000009800	LAMP	1	
2	A100010800	LAMP GUARD	2	
3	A100031301	BALLOON CLOTH CP	1	
7	2204500130	SEAL, NORMAL	1	
9	2204500230	PACKING	1	
13	A100028502	RED BALLOON COVER	1	
14	2204220130	PLATE (CAP)	1	
15	1800001000	SHEET (TOP)	1	
16	A300026901	PLATE (LAMP)	1	
17	2204400130	FRAME PIPE	4	
18	2204231530	SPRING (LAMP)	2	
19	E000009601	SOCKET ASSY	1	
20	A300032700	PLATE (LAMP HOLDER)	1	
21	2204231730	RUBBER (LAMP) L=210	1	
27	0014808025	BUTTON SCREW & WASHER (M8x25)	8	
28	0024304008	SCREW (M4x8)	8	
31	0025304025	SCREW & WASHER (M4x25)	2	
37	A400038400	CABLE (LAMP) 1 R CP	1	
38	A400038501	CABLE (LAMP) 1 W CP	1	
53	A300118000	CABLE, MAIN CP	1	
55	A300060202	SEAL, (TOP)	1	

Go to Discount-Equipment.com to order your parts

PARTS FINDER

**Search Website
by Part Number**



**Search Manual
Library For Parts
Manual & Lookup Part
Numbers – Purchase
or Request Quote**

Search Manuals

Enter your information to help us find the right parts manual for your machine.

* Brand:

* Model:

* Serial:

* Part Number:

SEARCH

**Can't Find Part or
Manual? Request Help
by Manufacturer,
Model & Description**

Parts Order Form

Please fill in the following information to help us find the right part for your machine.

Manufacturer:	<input type="text"/>
Model:	<input type="text"/>
Description:	<input type="text"/>
Part Number:	<input type="text"/>
Quantity:	<input type="text"/>
Notes:	<input type="text"/>

Submit

Discount-Equipment.com is your online resource for quality parts & equipment.

Florida: **561-964-4949** Outside Florida TOLL FREE: **877-690-3101**

Need parts?

Click on this link: <http://www.discount-equipment.com/category/5443-parts/> and choose one of the options to help get the right parts and equipment you are looking for. Please have the machine model and serial number available in order to help us get you the correct parts. If you don't find the part on the website or on one of the online manuals, please fill out the request form and one of our experienced staff members will get back to you with a quote for the right part that your machine needs.

We sell worldwide for the brands: Genie, Terex, JLG, MultiQuip, Mikasa, Essick, Whiteman, Mayco, Toro Stone, Diamond Products, Generac Magnum, Airman, Haulotte, Barreto, Power Blanket, Nifty Lift, Atlas Copco, Chicago Pneumatic, Allmand, Miller Curber, Skyjack, Lull, Skytrak, Tsurumi, Husquvarna Target, Stow, Wacker, Sakai, Mi-T-M, Sullair, Basic, Dynapac, MBW, Weber, Bartell, Bennar Newman, Haulotte, Ditch Runner, Menegotti, Morrison, Contec, Buddy, Crown, Edco, Wyco, Bomag, Laymor, EZ Trench, Bil-Jax, F.S. Curtis, Gehl Pavers, Heli, Honda, ICS/PowerGrit, IHI, Partner, Imer, Clipper, MMD, Koshin, Rice, CH&E, General Equipment, Amida, Coleman, NAC, Gradall, Square Shooter, Kent, Stanley, Tamco, Toku, Hatz, Kohler, Robin, Wisconsin, Northrock, Oztec, Toker TK, Rol-Air, APT, Wylie, Ingersoll Rand / Doosan, Innovatech, Con X, Ammann, Mecalac, Makinex, Smith Surface Prep, Small Line, Wanco, Yanmar