

PARTS MANUAL



MODELS

WBH-16

WBH-16E

WBH-16F

WBH-16EF

POWER BUGGY

**(HONDA GX390RT2QTT RECOIL START
GX390RT2QNB2 ELECTRIC START GASOLINE ENGINES)**

Revision #7 (04/07/23)



www.discount-equipment.com

THIS MANUAL MUST ACCOMPANY THE EQUIPMENT AT ALL TIMES.

PARTS FINDER

**Search Website
by Part Number**



**Search Manual
Library For Parts
Manual & Lookup Part
Numbers – Purchase
or Request Quote**

Search Manuals

Enter your information to help us find the right parts manual for your machine.

* Brand:

* Model:

* Serial:

* Part Number:

SEARCH

**Can't Find Part or
Manual? Request Help
by Manufacturer,
Model & Description**

Parts Order Form

Please fill in the following information to help us find the right part for your machine.

Manufacturer:	<input type="text"/>
Model:	<input type="text"/>
Description:	<input type="text"/>
Part Number:	<input type="text"/>
Quantity:	<input type="text"/>
Notes:	<input type="text"/>

Discount-Equipment.com is your online resource for quality parts & equipment.

Florida: **561-964-4949** Outside Florida TOLL FREE: **877-690-3101**

Need parts?

Click on this link: <http://www.discount-equipment.com/category/5443-parts/> and choose one of the options to help get the right parts and equipment you are looking for. Please have the machine model and serial number available in order to help us get you the correct parts. If you don't find the part on the website or on one of the online manuals, please fill out the request form and one of our experienced staff members will get back to you with a quote for the right part that your machine needs.

We sell worldwide for the brands: Genie, Terex, JLG, MultiQuip, Mikasa, Essick, Whiteman, Mayco, Toro Stone, Diamond Products, Generac Magnum, Airman, Haulotte, Barreto, Power Blanket, Nifty Lift, Atlas Copco, Chicago Pneumatic, Allmand, Miller Curber, Skyjack, Lull, Skytrak, Tsurumi, Husquvarna Target, Stow, Wacker, Sakai, Mi-T-M, Sullair, Basic, Dynapac, MBW, Weber, Bartell, Bennar Newman, Haulotte, Ditch Runner, Menegotti, Morrison, Contec, Buddy, Crown, Edco, Wyco, Bomag, Laymor, EZ Trench, Bil-Jax, F.S. Curtis, Gehl Pavers, Heli, Honda, ICS/PowerGrit, IHI, Partner, Imer, Clipper, MMD, Koshin, Rice, CH&E, General Equipment, Amida, Coleman, NAC, Gradall, Square Shooter, Kent, Stanley, Tamco, Toku, Hatz, Kohler, Robin, Wisconsin, Northrock, Oztec, Toker TK, Rol-Air, APT, Wylie, Ingersoll Rand / Doosan, Innovatech, Con X, Ammann, Mecalac, Makinex, Smith Surface Prep, Small Line, Wanco, Yanmar

TABLE OF CONTENTS

WBH-16 Series Power Buggy

Explanation of Code in Remarks Column.....	4
Suggested Spare Parts	5

Component Drawings

Nameplate and Decals Assembly.....	6–7
Hydraulic Drive Assembly.....	8–9
Hydraulic Pump Assembly.....	10–11
Hydraulic Dump Assembly.....	12–13
Pump and Coupling Assembly.....	14–15
Tub Assembly	16–17
Panel Assembly	18–19
Brake Assembly.....	20–21
Steering and Controls Assembly	22–23
Chassis Assembly	24–25
Handle/Foot Dump Controls Assembly.....	26–27
Hydraulic Oil Tank Assembly	28–29
Battery Assembly.....	30–31
Fuel Tank Assembly (Steel).....	32–33
Fuel Tank Assembly (Plastic).....	34–35
Engine Mounting Assembly	36–37
Engine Assembly	38–39
Engine Service Parts.....	40–41

NOTICE

Specifications and part numbers are subject to change without notice.

EXPLANATION OF CODE IN REMARKS COLUMN

The following section explains the different symbols and remarks used in the Parts section of this manual. Use the help numbers found on the back page of the manual if there are any questions.

NOTICE

The contents and part numbers listed in the parts section are subject to change **without notice**. Multiquip does not guarantee the availability of the parts listed.

SAMPLE PARTS LIST

NO.	PART NO.	PART NAME	QTY.	REMARKS
1	12345	BOLT.....	1	INCLUDES ITEMS W/%
2%		WASHER, 1/4 IN.....		NOT SOLD SEPARATELY
2%	12347	WASHER, 3/8 IN....	1	MQ-45T ONLY
3	12348	HOSE		A/R ...MAKE LOCALLY
4	12349	BEARING	1	S/N 2345B AND ABOVE

NO. Column

Unique Symbols — All items with same unique symbol

(@, #, +, %, or >) in the number column belong to the same assembly or kit, which is indicated by a note in the “Remarks” column.

Duplicate Item Numbers — Duplicate numbers indicate multiple part numbers, which are in effect for the same general item, such as different size saw blade guards in use or a part that has been updated on newer versions of the same machine.

NOTICE

When ordering a part that has more than one item number listed, check the remarks column for help in determining the proper part to order.

PART NO. Column

Numbers Used — Part numbers can be indicated by a number, a blank entry, or TBD.

TBD (To Be Determined) is generally used to show a part that has not been assigned a formal part number at the time of publication.

A blank entry generally indicates that the item is not sold separately or is not sold by Multiquip. Other entries will be clarified in the “Remarks” Column.

QTY. Column

Numbers Used — Item quantity can be indicated by a number, a blank entry, or A/R.

A/R (As Required) is generally used for hoses or other parts that are sold in bulk and cut to length.

A blank entry generally indicates that the item is not sold separately. Other entries will be clarified in the “Remarks” Column.

REMARKS Column

Some of the most common notes found in the “Remarks” Column are listed below. Other additional notes needed to describe the item can also be shown.

Assembly/Kit — All items on the parts list with the same unique symbol will be included when this item is purchased.

Indicated by:

“INCLUDES ITEMS W/(unique symbol)”

Serial Number Break — Used to list an effective serial number range where a particular part is used.

Indicated by:

“S/N XXXXX AND BELOW”

“S/N XXXX AND ABOVE”

“S/N XXXX TO S/N XXX”

Specific Model Number Use — Indicates that the part is used only with the specific model number or model number variant listed. It can also be used to show a part is NOT used on a specific model or model number variant.

Indicated by:

“XXXXX ONLY”

“NOT USED ON XXXX”

“Make/Obtain Locally” — Indicates that the part can be purchased at any hardware shop or made out of available items. Examples include battery cables, shims, and certain washers and nuts.

“Not Sold Separately” — Indicates that an item cannot be purchased as a separate item and is either part of an assembly/kit that can be purchased, or is not available for sale through Multiquip.

SUGGESTED SPARE PARTS

WBH16 SERIES POWER BUGGY

1 to 3 units

Qty.	P/N	Description
1	508667	FILTER, HYDRAULIC OIL
1	EM16477	CAP, HYDRAULIC OIL TANK
1	18035	PUMP, HYDRAULIC
1	18051	COUPLING, ENGINE SHAFT
2	512881	BRAKE BAND ASSY.
1	18145	ROD, BRAKE CONTROL
1	18166	CAP, FUEL (NON EPA, 4-IN)
1	520820	CAP, FUEL (EPA, 2-IN)
5	EM20763	FILTER, IN-LINE FUEL
1	18131	SWITCH, KILL
1	18133	CABLE, THROTTLE
1	18132	LEVER, THROTTLE
1	18029	WHEEL, DRIVE, PNEUMATIC
1	18029F	WHEEL, DRIVE, FOAM
1	18049	WHEEL, STRG., PNEU.
1	18049F	WHEEL, STEERING, FOAM
1	18016	CABLE, PARK BRAKE

NOTICE

Part numbers on this Suggested Spare Parts list may supersede/replace the part numbers shown in the following parts lists.

ENGINE HONDA GX390RT2QTT (RECOIL START)

1 to 3 units

Qty.	P/N	Description
3	9807955846	SPARK PLUG
3	11078	KEY, IGNITION SWITCH
3	828461Z5T305	GRIP, STARTER
1	28462ZE3W01	ROPE, STARTER
3	17210ZE3010	AIR FILTER, ELEMENT
3	17218ZE3000	AIR FILTER, OUTER

ENGINE HONDA GX390RT2QNB2 (ELECTRIC START)

1 to 3 units

Qty.	P/N	Description
3	9807955846	SPARK PLUG
3	11078	KEY, IGNITION SWITCH
3	17210ZE3505	AIR FILTER, ELEM. (DUAL)
3	17218ZE3505	AIR FILTER, OUTER

NAMEPLATE AND DECALS ASSY.

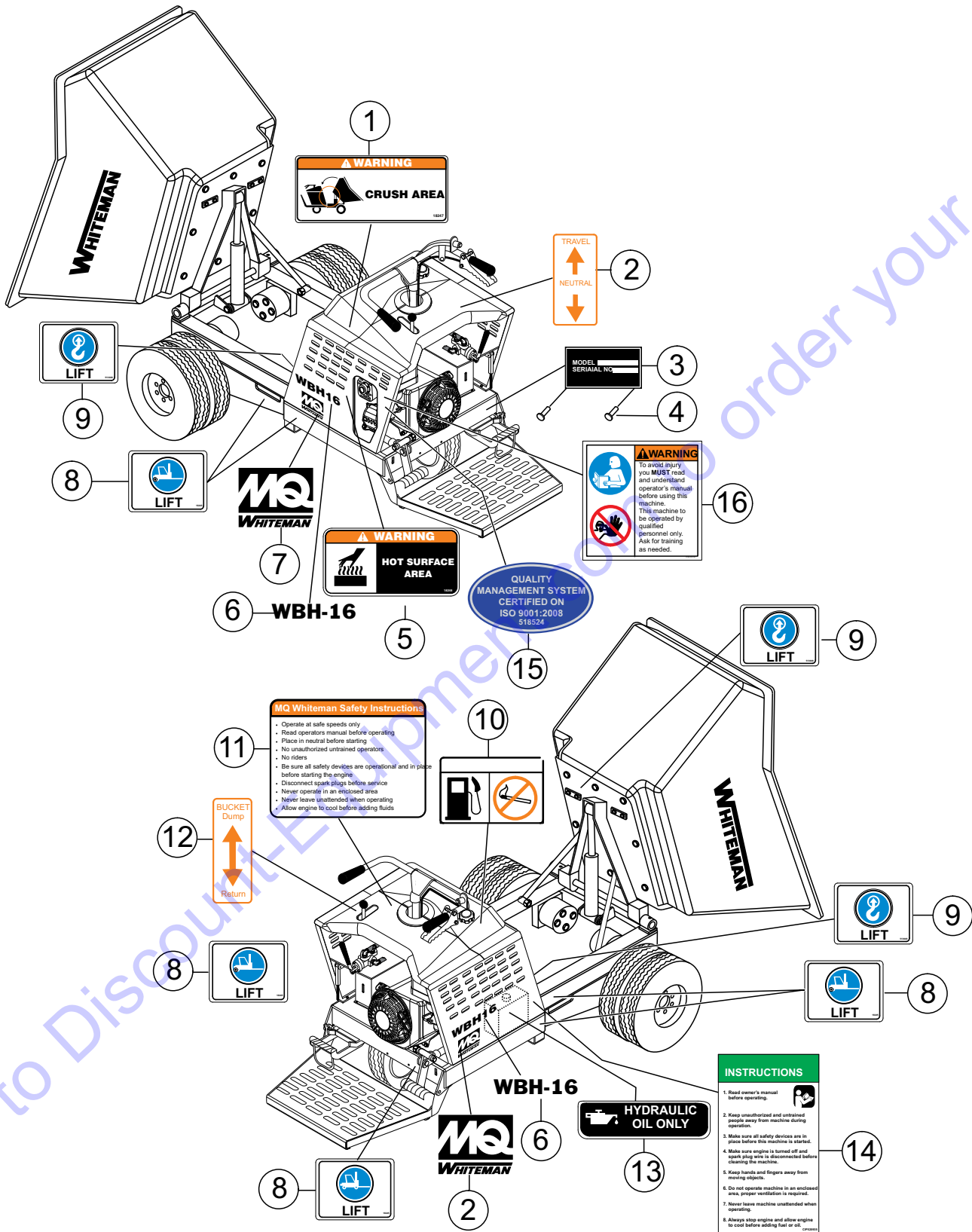

NAMEPLATE AND DECALS ASSY.

<u>NO.</u>	<u>PART NO.</u>	<u>PART NAME</u>	<u>QTY.</u>	<u>REMARKS</u>
1	18247	DECAL, CRUSH WARNING	1	
2		DECAL, TRAVEL LEVER DIRECTION.....	1.....	MOLDED INTO FUEL TANK COVER
3		PLATE, SERIAL NUMBER.....	1.....	CONTACT MQ PARTS DEPT.
4	491757	RIVET, I.D. PLATE	2	
5	18248	DECAL, HOT SURFACE WARNING	1	
6	18251	DECAL, WBH-16	2	
7	18252	DECAL, MQ WHITEMAN	2	
8	18245	DECAL, FORKLIFT LIFTING	6	
9	513608	DECAL, LIFTING HOOK	3	
10		DECAL, GASOLINE ONLY	1.....	MOLDED INTO FUEL TANK COVER
11		DECAL, WHITEMAN SAFETY INSTRUCTIONS.....	1.....	MOLDED INTO FUEL TANK COVER
12		DECAL, BUCKET DUMP LEVER	1.....	MOLDED INTO FUEL TANK COVER
13	EM985	DECAL, HYDRAULIC OIL	1	
14	520935	DECAL, SAFETY INSTRUCTIONS	1	
15	518524	DECAL, ISO 9001:2008	1	
16	35137	DECAL, READ MANUAL, ASK FOR TRAINING	1	

HYDRAULIC DRIVE ASSY.

VIEW FROM OPERATOR'S PLATFORM

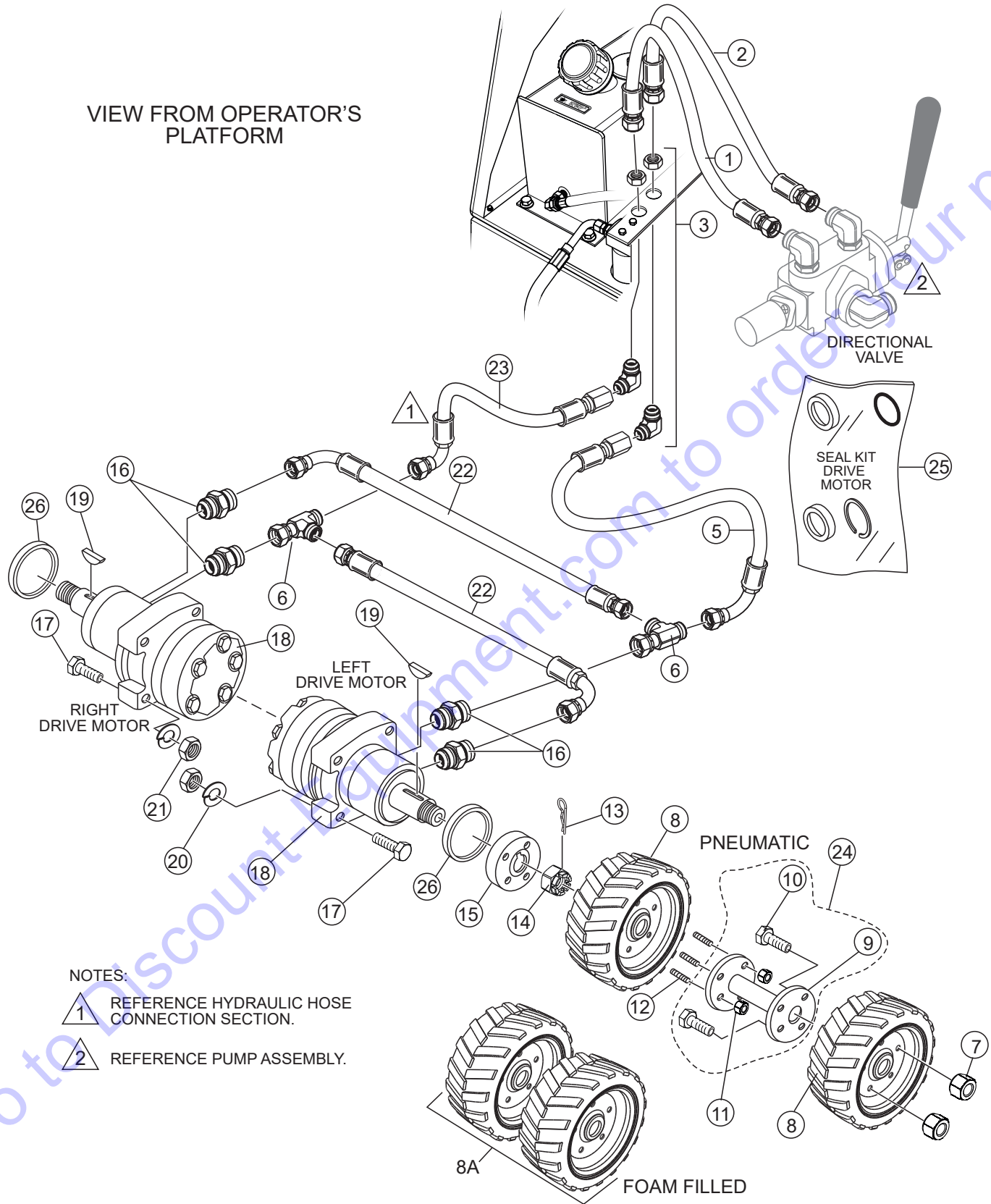

NOTES:

- 1 REFERENCE HYDRAULIC HOSE CONNECTION SECTION.
- 2 REFERENCE PUMP ASSEMBLY.

HYDRAULIC DRIVE ASSY.

<u>NO.</u>	<u>PART NO.</u>	<u>PART NAME</u>	<u>QTY.</u>	<u>REMARKS</u>
1	18265M	HOSE, DIRECTION VALVE.....	1	RIGHT-DRIVE MOTOR
2	18264M	HOSE, DIRECTION VALVE.....	1	LEFT-DRIVE MOTOR
3	511810	ADAPTER, ELBOW	2	
5	18276M	HOSE, LH HYDRAULIC MOTOR	1	
6	512189	ADAPTER, TEE CONNECTOR	2	
7	492527	NUT, HEX 1/2"-20	8	
8	18029	WHEEL, DRIVE ASSY. FRONT.....	4	PNEUMATIC TIRE
8A	18029F	WHEEL, DRIVE ASSY. FRONT.....	4	FOAM FILLED TIRE
9\$	511692	FLANGE, HUB	2	
10\$	18237	LUG BOLT/HUB FLANGE	8	
11	492584	NUT, HEX 1/2"-13 NYLON.....	8	REPLACES P/N 6109160
12	18190	SCREW, HUB STUD 1/2"-20 X 2-3/4"	8	
13	491689	KEY, COTTER 1/8" X 2	2	NOT USED FOR WHB16EF S/N 1P02 AND ABOVE BEGINNING FEB. 2023
14	PT018038	NUT, CASTLE 1-1/8"-18	2	
15	803281	HUB, DRIVE (IND) (WBH16/WBH16E/WBH16F)	2	
15	803281	HUB, DRIVE (IND) (WBH16EF)	2	S/N 1P01 AND BELOW USED UP TO JAN. 31, 2023
15	809428	HUB, DRIVE (IND) (WBH16EF)	2	S/N 1P02 AND ABOVE EFFECTIVE FEB. 2023
16	3365	ADAPTER, STRAIGHT	4	
17	505718	HEX. HEAD BOLT 1/2-20 X 2 3/4.....	8	WBH16/WBH16E/WBH16F
17	505718	HEX. HEAD BOLT 1/2-20 X 2 3/4.....	8	WBH16EF S/N 1P01 AND BELOW USED UP TO JAN. 31, 2023
17	EM210	HEX. HEAD BOLT 1/2-20 X 3 1/4.....	8	WBH16EF S/N 1P02 AND ABOVE EFFECTIVE FEB. 2023
18	18011	MOTOR, HYDRAULIC DRIVE.....	2	WBH16/WBH16E/WBH16F
18	18011	MOTOR, HYDRAULIC DRIVE.....	2	WBH16EF S/N 1P01 AND BELOW USED UP TO JAN. 31, 2023
18	809239	MOTOR, HYDRAULIC DRIVE.....	2	WBH16EF S/N 1P02 AND ABOVE EFFECTIVE FEB. 2023
19	3311	KEY, 7 MM X 8 MM X 1-1/4".....	2	REPLACES P/N PE449105
20	6109180	WASHER, LOCK 1/2".....	8	WBH16/WBH16E/WBH16F
20	6109180	WASHER, LOCK 1/2".....	8	WBH16EF S/N 1P01 AND BELOW USED UP TO JAN. 31, 2023

HYDRAULIC DRIVE ASSY. (CONT'D.)

VIEW FROM OPERATOR'S PLATFORM

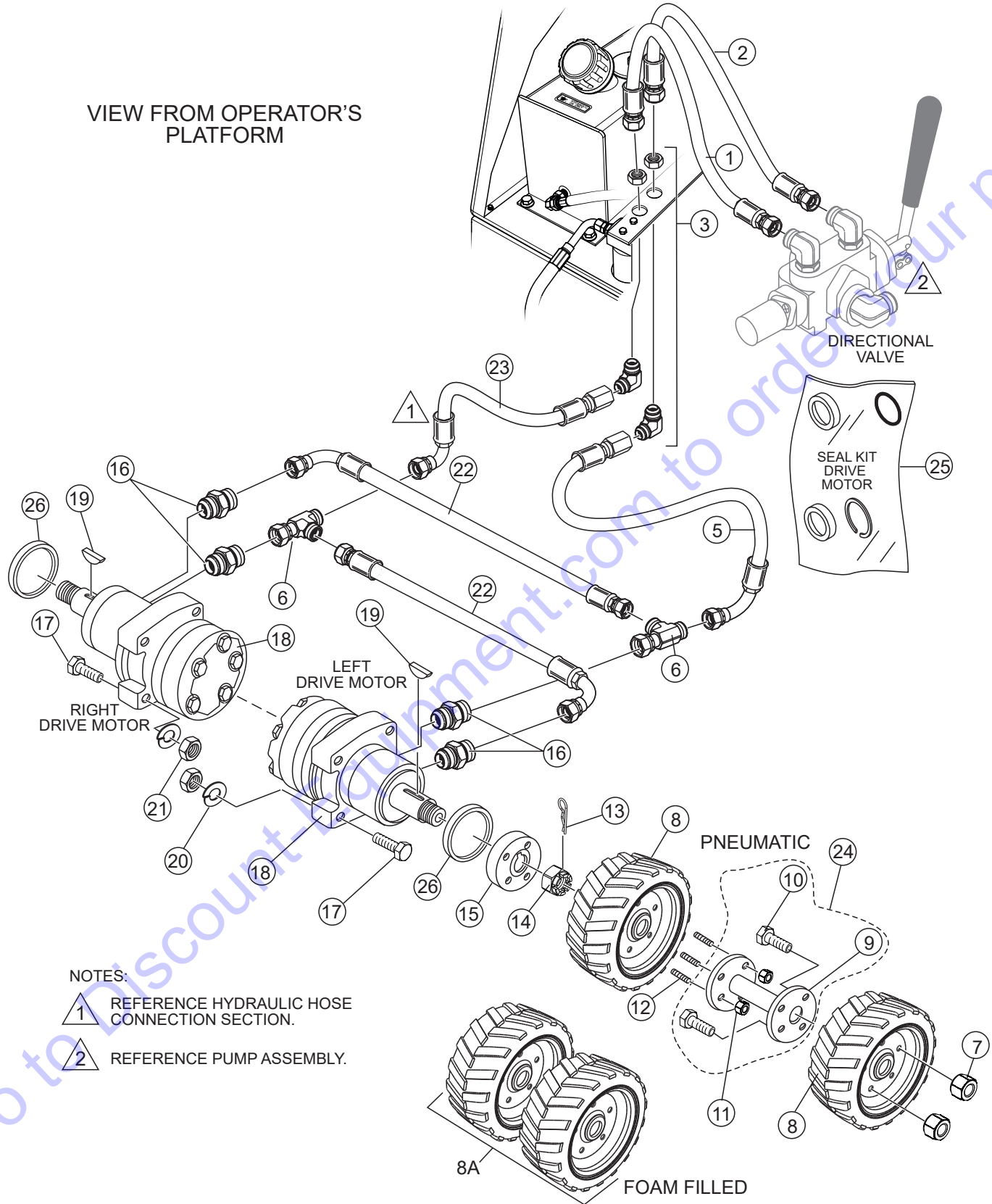

NOTES:

- 1 REFERENCE HYDRAULIC HOSE CONNECTION SECTION.
- 2 REFERENCE PUMP ASSEMBLY.

HYDRAULIC DRIVE ASSY. (CONT'D.)

<u>NO.</u>	<u>PART NO.</u>	<u>PART NAME</u>	<u>QTY.</u>	<u>REMARKS</u>
21	6109160	NUT, HEX 1/2"-13	8	WBH16/WBH16E/WBH16F
21	6109160	NUT, HEX 1/2"-13	8	WBH16EF S/N 1P01 AND BELOW USED UP TO JAN. 31, 2023
21	492584	NUT, NYLOC 1/2"-13	8	WBH16EF S/N 1P02 AND ABOVE EFFECTIVE FEB. 2023
22	18027	HOSE, DRIVER MOTOR CROSSOVER	2	
23	18275M	HOSE, RH HYDRAULIC MOTOR	1	
24	516528	FLANGE HUB ASSY.	1	INCLUDES ITEMS W/\$
25	18011SK	SEAL KIT, DRIVE MOTOR	1	
26	809610	SPACER RING (WBH16EF)	2	S/N 1P02 AND ABOVE EFFECTIVE FEB. 2023

Go to Discount-Equipment.com to order your parts

HYDRAULIC PUMP ASSY.

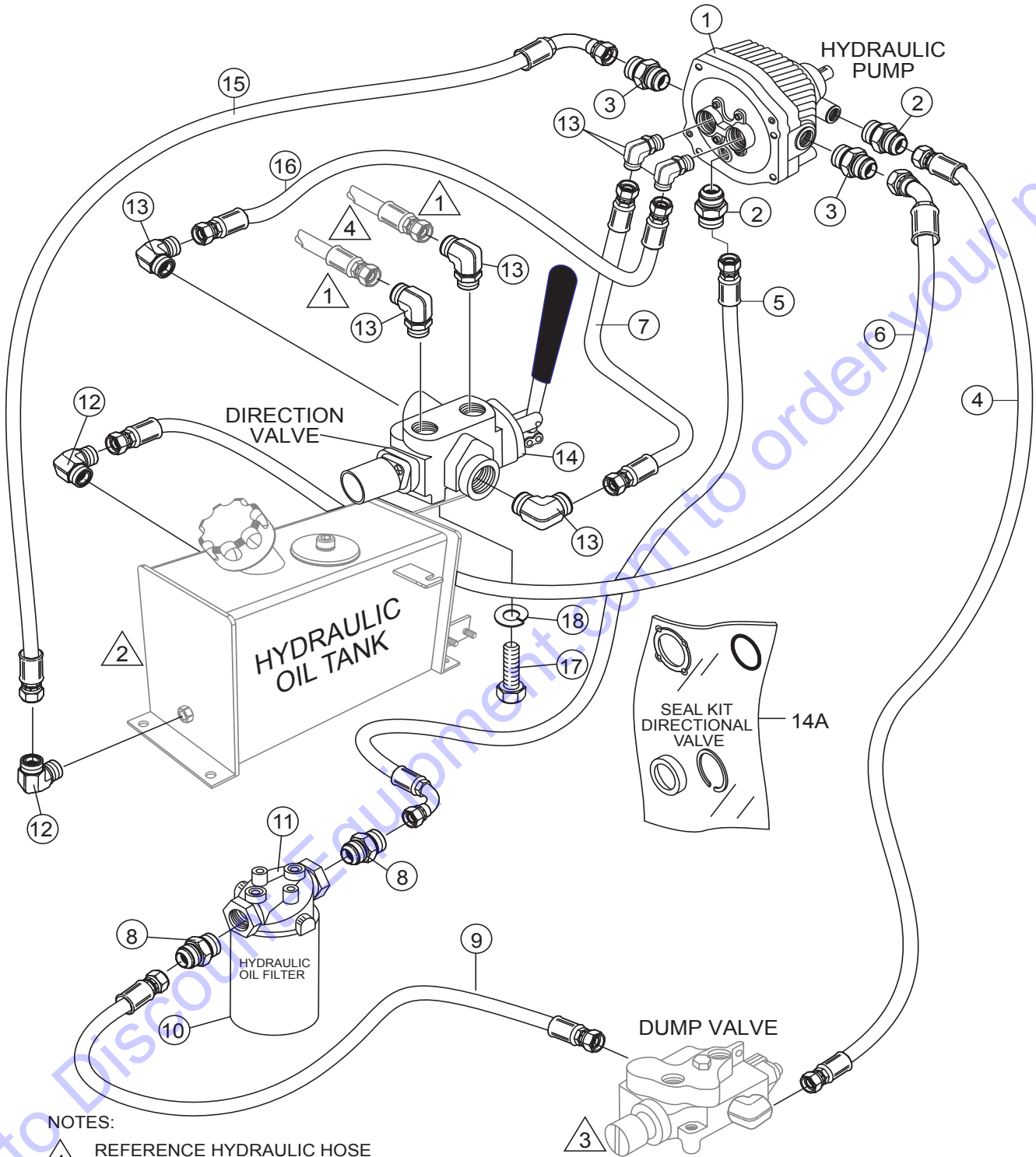

NOTES:

- 1 REFERENCE HYDRAULIC HOSE CONNECTION SECTION.
- 2 REFERENCE HYDRAULIC OIL TANK ASSEMBLY.
- 3 REFERENCE DUMP VALVE ASSEMBLY.
- 4 REFERENCE HYDRAULIC DRIVE ASSEMBLY ITEMS 1 AND 2 FOR HOSE PART NUMBERS

HYDRAULIC PUMP ASSY.

<u>NO.</u>	<u>PART NO.</u>	<u>PART NAME</u>	<u>QTY.</u>	<u>REMARKS</u>
1	18035	PUMP, HYDRAULIC	1	
2	511808	ADAPTER, STRAIGHT	2	
3	3365	ADAPTER, STRAIGHT	2	
4	18256M	HOSE, PUMP TO DUMP VALVE	1	
5	18258M	HOSE, FILTER TO PUMP	1	
6	18261M	HOSE, PUMP TO TANK	1	
7	18265M	HOSE, PUMP TO DIRECTION VALVE.....	1.....	REPLACES P/N 18263M
8	512190	ADAPTER, STRAIGHT	2	
9	18257M	HOSE, FILTER TO DUMP VALVE	1	
10	508667	FILTER, HYDRAULIC	1	
11	508664	HYDRAULIC FILTER HEAD	1	
12	511799	ADAPTER, ELBOW	2	
13	3322	ADAPTER, ELBOW	6	
14	18058	VALVE, DIRECTION CONTROL, TRAVEL	1	
14A	18058SK	SEAL KIT, DIRECTIONAL VALVE	1	
15	18262M	HOSE, TANK TO PUMP	1	
16	18266M	HOSE, PUMP TO DIRECTION VALVE	1	
17	EM963055	HEX HEAD CAP SCREW.....	2.....	REPLACES P/N 492373
18	0166 A	WASHER, LOCK 3/8".....	2.....	REPLACES P/N 492624

HYDRAULIC DUMP ASSY.

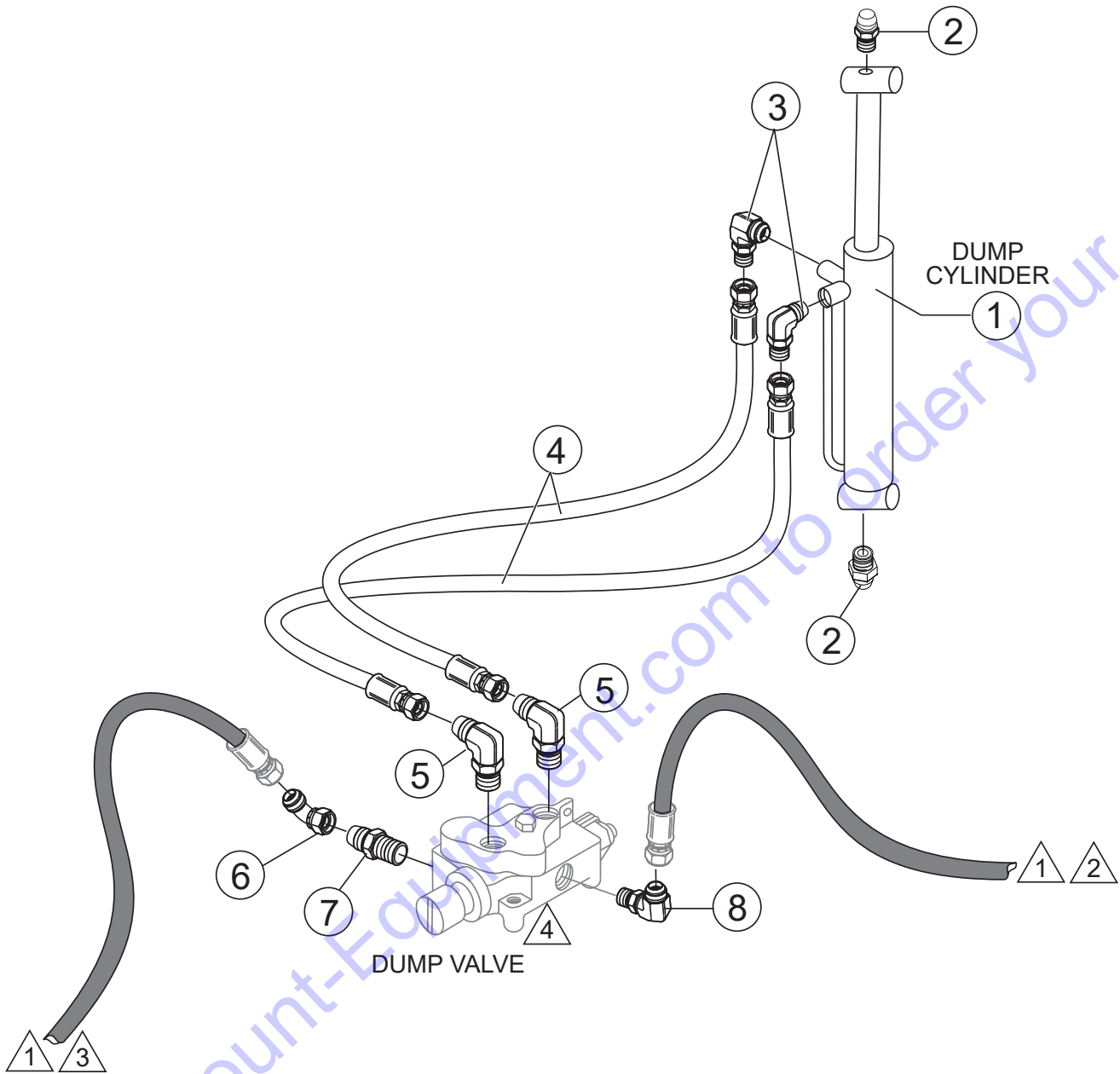

NOTES:

- 1 REFERENCE HYDRAULIC HOSE CONNECTION SECTION.
- 2 REFERENCE HYDRAULIC PUMP ASSEMBLY ITEM 4 FOR HOSE PART NUMBER.
- 3 REFERENCE HYDRAULIC PUMP ASSEMBLY ITEM 9 FOR HOSE PART NUMBER.
- 4 REFERENCE HANDLE/FOOT DUMP CONTROLS ASSEMBLY ITEM 8 FOR DUMP VALVE PART NUMBER.

HYDRAULIC DUMP ASSY.

<u>NO.</u>	<u>PART NO.</u>	<u>PART NAME</u>	<u>QTY.</u>	<u>REMARKS</u>
1	18022	CYLINDER, HYDRAULIC DUMP	1	
2	491705	ZERK FITTING	2	
3	511803	ADAPTER, ELBOW	2	
4	18020	HOSE, DUMP VALVE TO HYD. PISTON	2	
5	511804	ADAPTER, ELBOW MALE	2	
6	512234	ADAPTER, ELBOW	1	
7	511806	ADAPTER, STRAIGHT	1	
8	506191	ADAPTER, ELBOW	1	

Go to Discount-Equipment.com to order your parts

PUMP AND COUPLING ASSY.

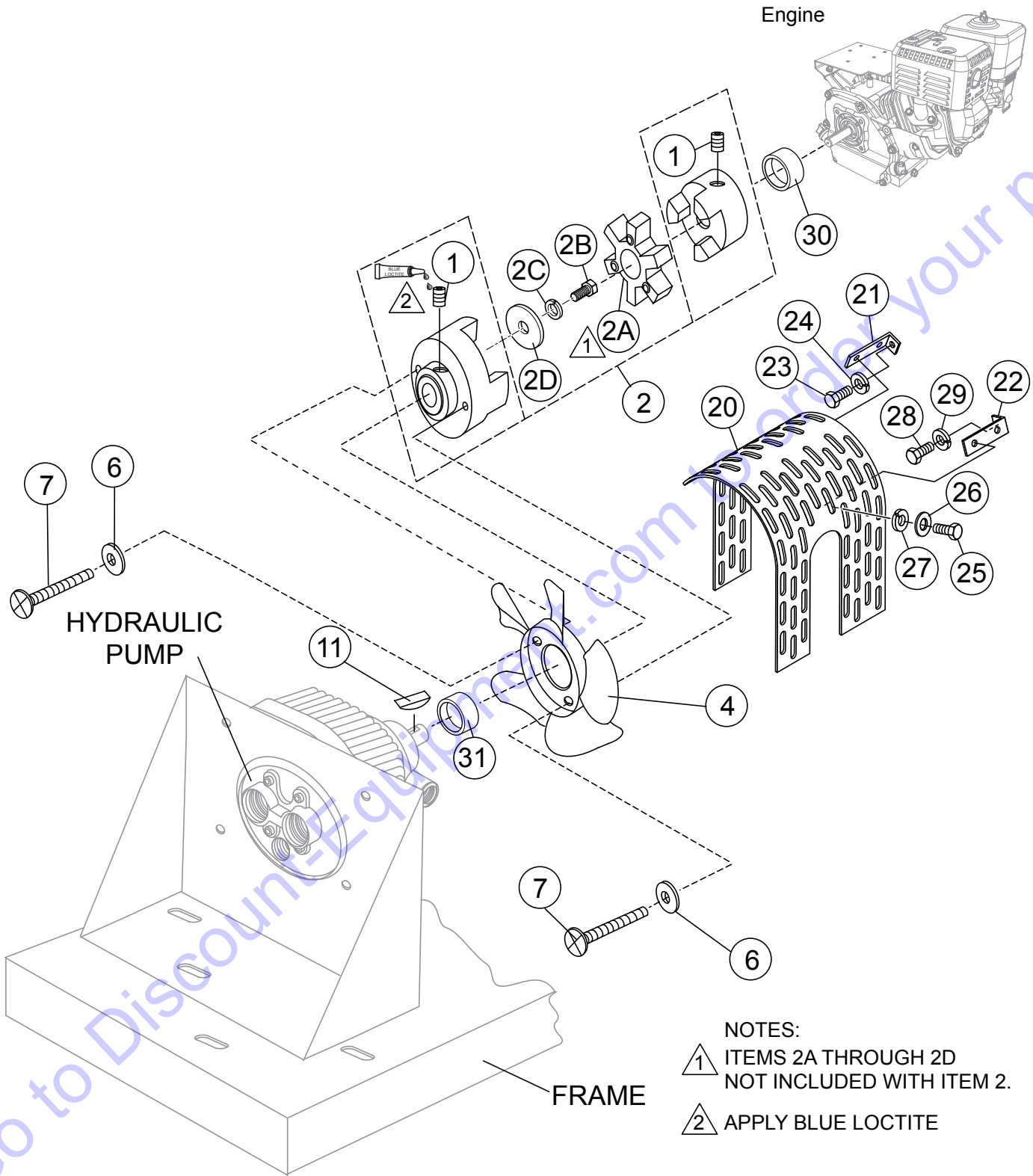

PUMP AND COUPLING ASSY.

<u>NO.</u>	<u>PART NO.</u>	<u>PART NAME</u>	<u>QTY.</u>	<u>REMARKS</u>
1#	492472	SCREW, ALLEN HEAD 3/8"-16 X 3/4"	2	
2	18051	COUPLING, ENGINE SHAFT.....	1.....	INCLUDES ITEMS W/#
2A	18051RS	SPIDER, URETHANE	1	
2B	492356	SCREW, 1/4" X 3/4" GRD 5	1	
2C	492622	WASHER, LOCK 1/4"	1	
2D	EM923057	WASHER, FLAT 3/4".....	1.....	REPLACES P/N 504451
4	18112	FAN	1	
6	492596	WASHER, FLAT 1/4"	2	
7	492355	SCREW, HHC 1/4"-20 X 1/2"	2	
11	506250	KEY, WOODRUFF	1	
20	513761	FAN GUARD	1	
21	512493	BRACKET, LONG	1	
22	513737	BRACKET, SHORT	1	
23	492373	BOLT, C/H 3/8" X 3/4" NC GRD 5	1	
24	492624	WASHER, LOCK 3/8"	1	
25	512367	BOLT, C/H 3/16" X 1/2" NC GRD 2	4	
26	492595	WASHER, FLAT 3/16"	4	
27	492621	WASHER, LOCK 3/16"	4	
28	492438	BOLT, C/H 5/16" X 1" NF GRD 5	1	
29	492623	WASHER, LOCK 5/16"	1	
30	802442	LOCK COLLAR	1	
31	803009	BUSHING, HYDRAULIC PUMP	1	

TUB ASSY.

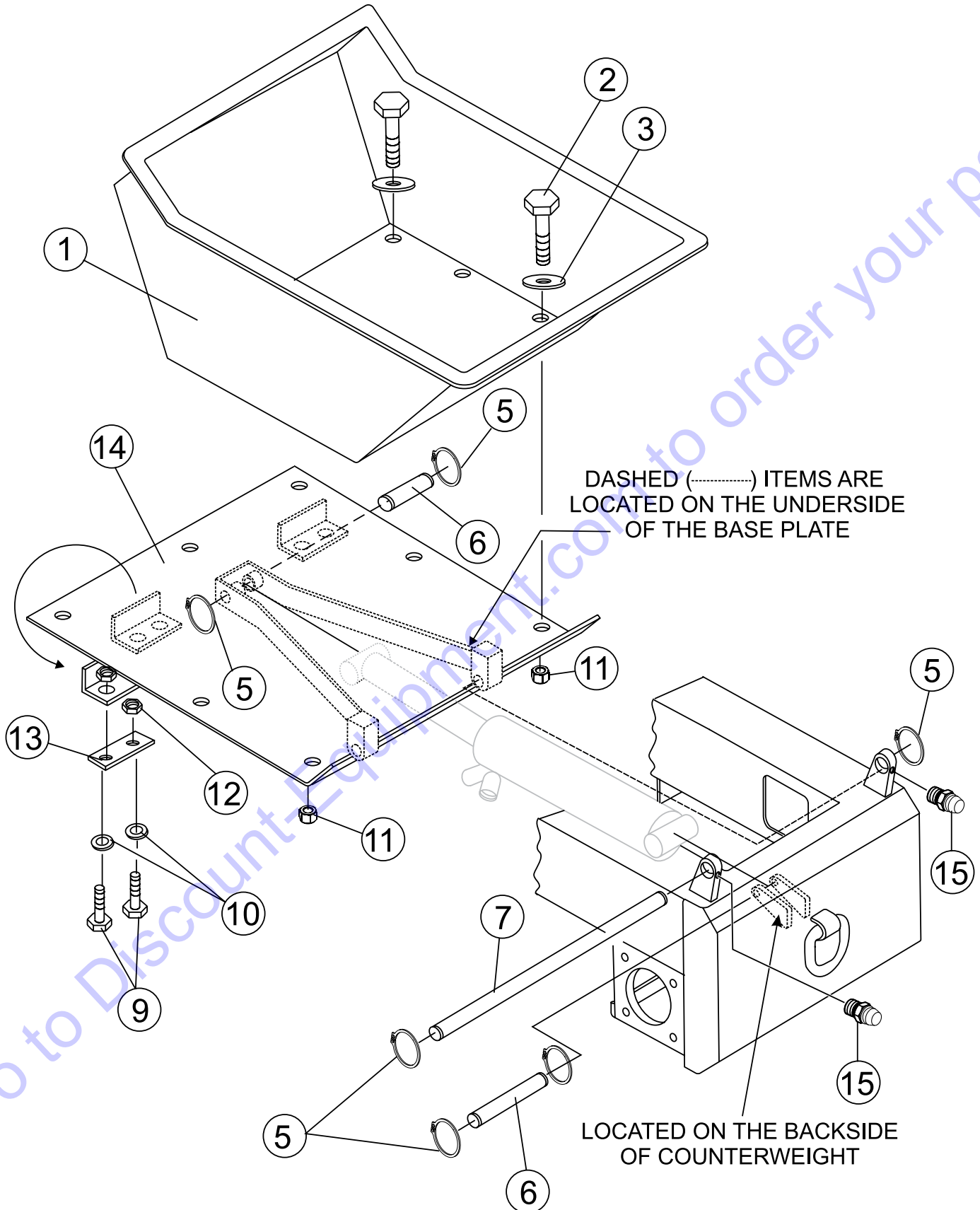

TUB ASSY.

<u>NO.</u>	<u>PART NO.</u>	<u>PART NAME</u>	<u>QTY.</u>	<u>REMARKS</u>
1	18004	TUB, PLASTIC, 16 CU. FT.	1	
2	492313	SCREW, HHC 3/8"-16 X 1-1/2"	9	
3	512193	WASHER, FLAT 3/8" LARGE	9	
5	490957	RING, SNAP	6	
6	18130	PIN, HYD. PISTON CROSS	2	
7	18129	PIN, TUB FRAME CROSS	1	
9	0202	SCREW, HHC 5/16"-18 X 1 ZINC.....	4	REPLACES P/N 492364
10	492597	WASHER, FLAT 9.5 X 22.2	8	
11	492583	NUT, NYLOC 3/8"-16	9	
12	492582	NUT, NYLOC 5/16"-18	4	
13	512279	SUPPORT, BUM STOP	2	
14	18099	FRAME, TUB MOUNT, 16 CU. FT.	1	BEFORE JULY 2020
14	522262	FRAME, TUB MOUNT, 16 CU. FT.	1	EFFECTIVE JULY 2020
15	EM916019	GREASE FITTING	2	REPLACES P/N 491705

PANEL ASSY.

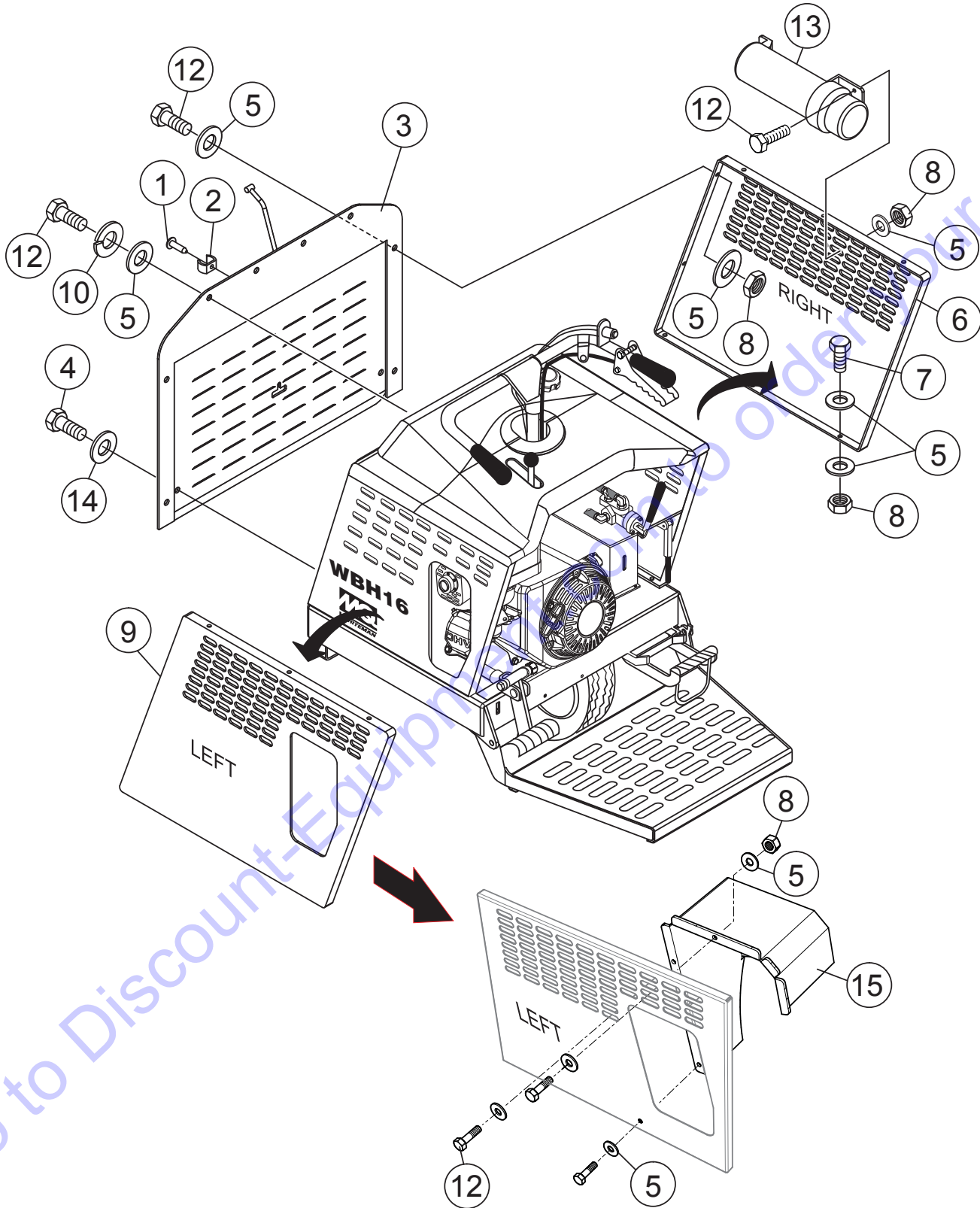

PANEL ASSY.

<u>NO.</u>	<u>PART NO.</u>	<u>PART NAME</u>	<u>QTY.</u>	<u>REMARKS</u>
1	503978	POP RIVET AM-56	1	
2	511474	FASTENER, ACCESS DOOR	1	
3	18008	DOOR, ACCESS	1	
4	492355	SCREW, 1/4" X 1/2" NC GRD 5	2	
5	492597	WASHER, FLAT 3/8"	32	
6	18141	COVER, RIGHT/SIDE ENGINE	1	
7	492364	SCREW, HHC 5/16"-18 X 1	6	
8	492582	NUT, NYLOC 5/16"-18	9	
9	801026	COVER, LEFT/SIDE ENGINE	1	
10	492623	WASHER, LOCK 5/16"	4	
12	492363	SCREW, HHC 5/16" X 3/4" NC GRD 5	10	
13	23297	MANUAL HOLDER	1	
14	EM923057	WASHER, 1/4"	4.....	REPLACES P/N 492596
15	802755	MUFFLER DEFLECTOR	1	

BRAKE ASSY.

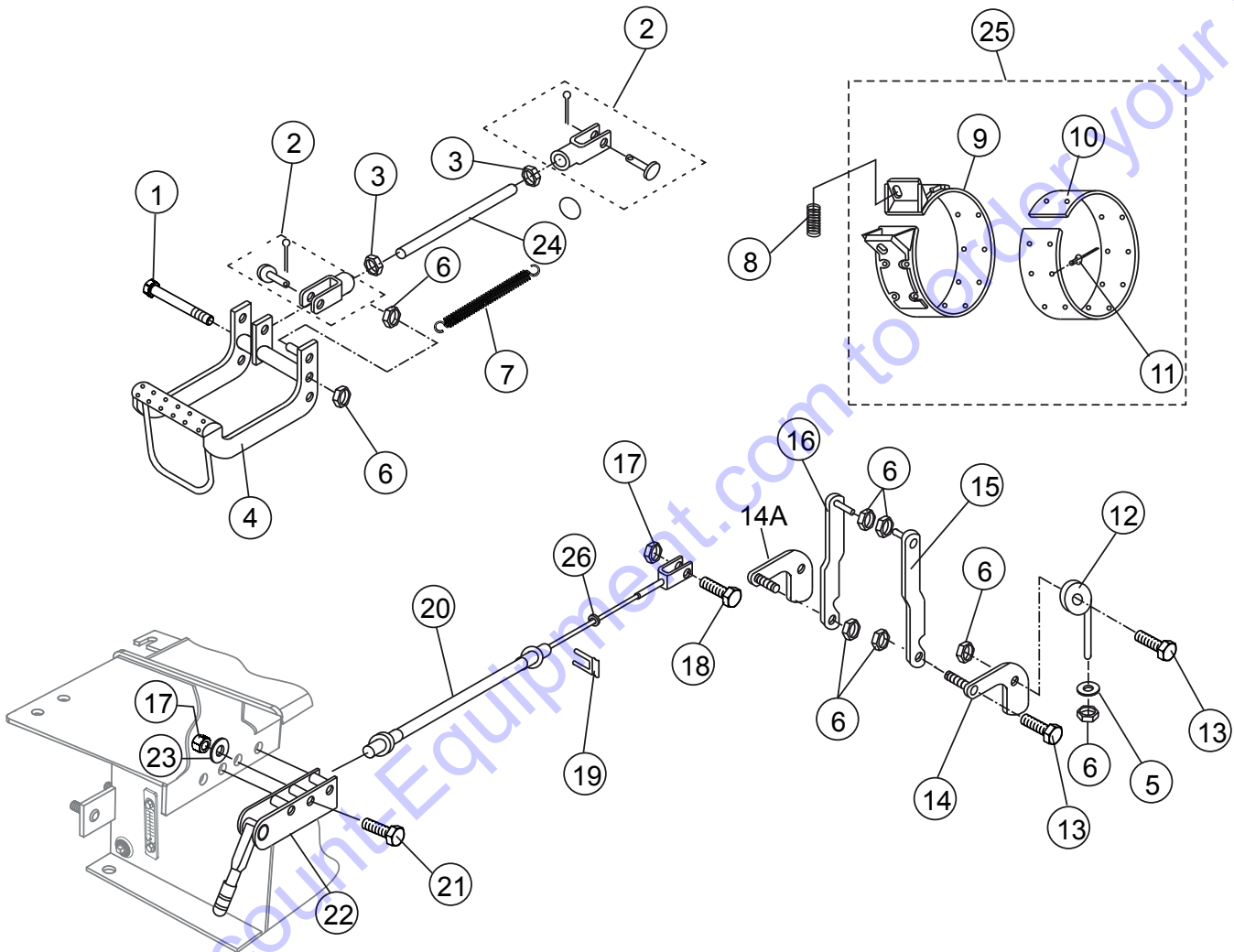

BRAKE ASSY.

<u>NO.</u>	<u>PART NO.</u>	<u>PART NAME</u>	<u>QTY.</u>	<u>REMARKS</u>
1	511762	SCREW, HHC 1/2"-13 X 8	1	
2	511698	CLEVIS, ASSY. BRAKE	2	
3	492574	NUT, HEX 3/8"-24 NF	2	
4	18111	PEDAL, BRAKE	1	
5	621	WASHER, FLAT 1/2"	1	
6	492584	NUT, NYLOC 1/2"-13	10	
7	18167	SPRING, BRAKE PEDAL	1	
8	18307	SPRING, BRAKE	2	
9\$		BAND, BRAKE.....	2.....	NOT SOLD SEPARATELY
10\$		LINING, BRAKE.....	2.....	NOT SOLD SEPARATELY
11\$	503723	RIVET, BRAKE LINING	56	
12	18303	SHAFT, CRANK PIN	2	
13	492395	SCREW, HHC 1/2"-13 X 1-3/4"	2	
14	512602	BRAKE LEVER, LEFT	1	
14A	512601	BRAKE LEVER, RIGHT	1	
15	18032	LINKAGE, RIGHT BRAKE	1	
16	18314	LINKAGE, LEFT BRAKE	1	
17	492582	NUT, NYLOC 5/16"	3	
18	492365	SCREW, HHC 5/16" X 1-1/4" NC GRD 5	1	
19	505170	CLIP, PARK CABLE	1	
20	18016	CABLE, PARK BRAKE	1	
21	492367	SCREW, HHC 5/16"-18 X 1-3/4"	3	
22	18057	LEVER, ASSY. PARK BRAKE	1	
23	492597	WASHER, FLAT 3/8"	6	
24	18145	ROD, BRAKE CONTROL	1	
25	512881	BRAKE BAND ASSY.....	2.....	INCLUDES ITEMS W/\$
26	492600	WASHER, FLAT 1/2"	2	

STEERING AND CONTROLS ASSY.

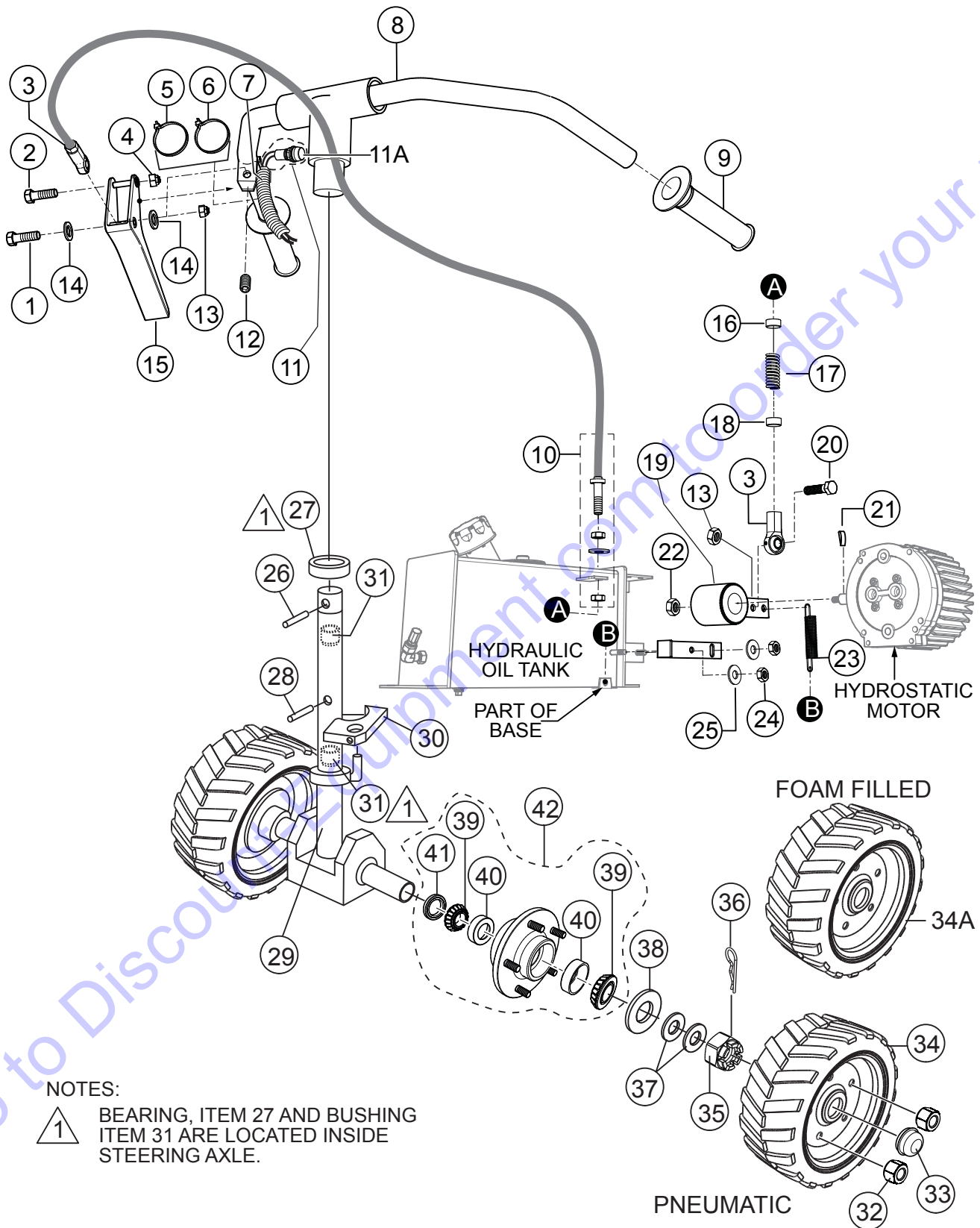

STEERING AND CONTROLS ASSY.

<u>NO.</u>	<u>PART NO.</u>	<u>PART NAME</u>	<u>QTY.</u>	<u>REMARKS</u>
1	2508	SCREW, HHC 1/4"-20 X 2-1/4".....	1.....	REPLACES P/N 512414
2	492369	SCREW, HHC 5/16"-18 X 2-1/4"	1	
3	18183	ROD-END, THROTTLE CABLE	2	
4	492582	NUT, NYLOC 5/16"-18	1	
5	504505	WRAP, TIE 4.6 X 360 MM	1	
6	491030	WRAP, TIE 2.5 X 142 MM	2	
7	505304	COVER, WIRE (LOOM)	1	
8	18242	HANDLE BAR	1	
9	15081	GRIP, HANDLE	2	
10	18133	CABLE, THROTTLE	1	
11	515417	SWITCH HARNESS ASSY.	1	
11A	18131	SWITCH, KILL.....	1.....	REPLACES P/N 18025
12	492465	SCREW, ALLEN HEAD 1/4"-20 X 3/8"	1	
13	492581	NUT, NYLOC 1/4"-20	2	
14	509161	WASHER, FLAT 5/16"	2	
15	18132	LEVER, THROTTLE	1	
16	18182	BUSHING, CABLE	1	
17	18176	SPRING	1	
18	18181	BUSHING, CABLE	1	
19	18061	LEVER, CONTROL	1	
20	492357	SCREW, HHC 1/4"-20 X 1	1	
21	511717	KEY, WOODRUFF 1/8" X 5/8"	1	
22	492584	NUT, NYLOC 1/2"-13	1	
23	18177	SPRING	1	
24	492583	NUT, NYLOC 3/8"	2	
25	492598	WASHER, FLAT 3/8"	2	
26	491723	PIN, STEERING SHAFT	1	
27	18238	BEARING, STEERING SHAFT	1	
28	512186	PIN, STEERING SHAFT	1	
29	513360	STEERING COLUMN	1	
30	803151	STOP, STEERING	1	
31	512200	BUSHING, BRONZE	2	
32	8115	NUT LUG	8	
33	3469	CAP, DUST	2	
34	18049	WHEEL, STEERING ASSY. REAR.....	2.....	PNEUMATIC TIRE
34A	18049F	WHEEL, STEERING ASSY. REAR.....	2.....	FOAM FILLED TIRE
35	512210	NUT, CASTLE	2	
36	491688	PIN, COTTER 1/8" X 1-1/2"	2	
37	EM501299	WASHER, REAR WHEEL HUB	4	
38	511159	WASHER, FLAT 1"	2	
39#	EM903113	BEARING CONE	4	
40#	EM903012	BEARING CUP	4	
41#	EM914288	SEAL	2	
42	EM941306	HUB, REAR WHEEL.....	2.....	INCLUDES ITEMS W/#

CHASSIS ASSY.

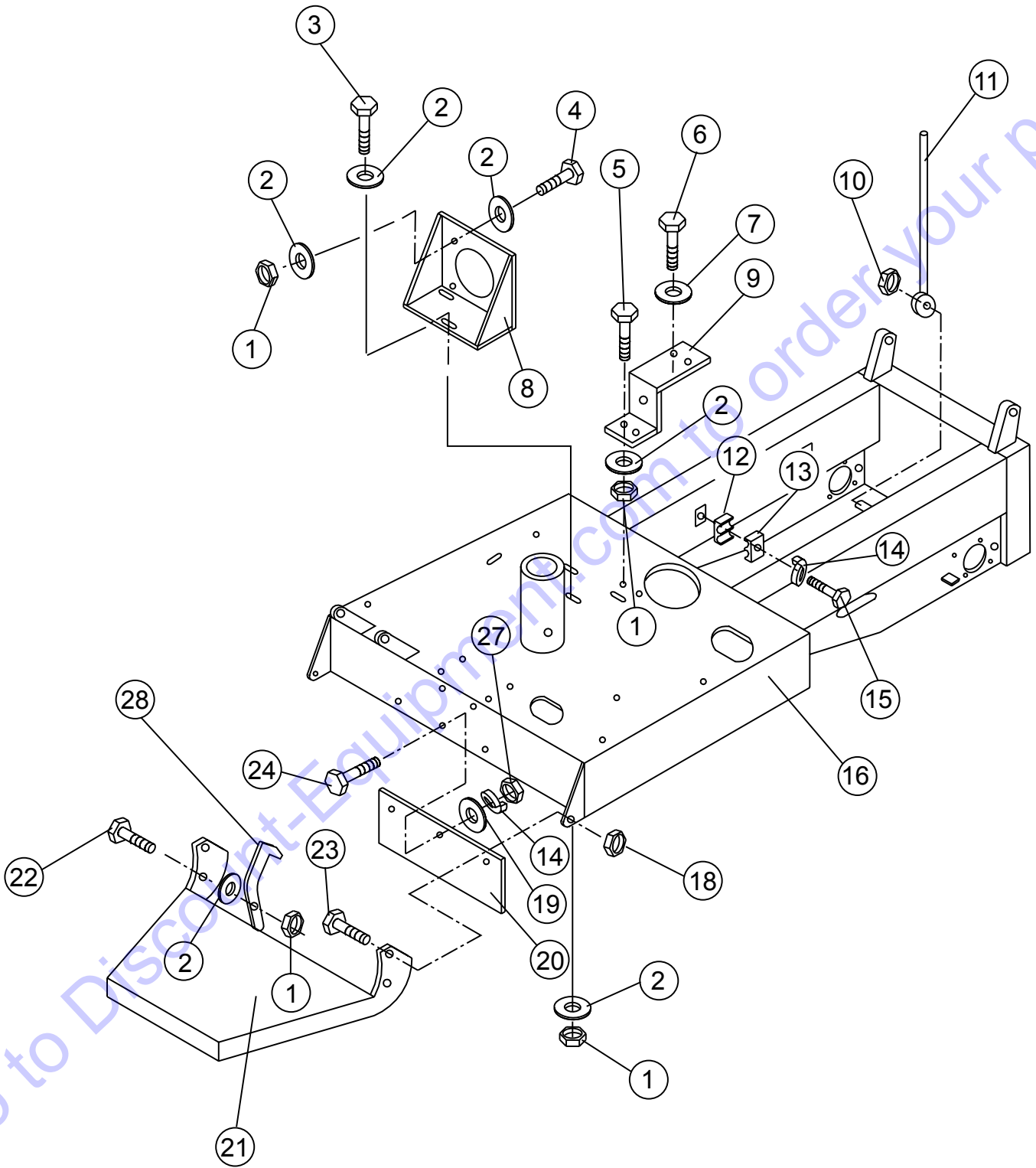

CHASSIS ASSY.

<u>NO.</u>	<u>PART NO.</u>	<u>PART NAME</u>	<u>QTY.</u>	<u>REMARKS</u>
1	492583	NUT, NYLOC 3/8"	10	
2	492598	WASHER, FLAT 3/8"	18	
3	492313	SCREW, HHC 3/8"-16 X 1-1/2"	3	
4	503112	SCREW, HHC 3/8"-16 X 2-3/4"	4	
5	EM963610	CAP SCREW 3/8" X 1-1/4" NC GRD 8.....	2.....	REPLACES P/N 492375
6	492356	SCREW, HHC 1/4" X 3/4" NC GRD 5	2	
7	492622	WASHER, LOCK 1/4"	2	
8	512196	BRACKET, HYD. PUMP MOUNTING	1	
9	18146	MOUNT, OIL FILTER	1	
10	505069	NUT, NYLOC 3/4"-10	1	
11	18198	ROD, TUB PROP (WBH16/WBH16E/WBH16F)	1	
11	18198	ROD, TUB PROP (WBH16EF)	1.....	S/N 1P01 AND BELOW USED UP TO JAN. 31, 2023
11	809510	ROD, TUB PROP (WBH16EF)	1.....	S/N 1P02 AND ABOVE EFFECTIVE FEB. 2023
12	505976	CLAMP, BRACKET	2	
13	506185	CLAMP, BRACKET	2	
14	492623	WASHER, LOCK 5/16"	5	
15	492366	SCREW, HHC 5/16"-18 X 1-1/2"	2	
16	18047	CHASSIS (WBH16/WBH16E/WBH16F)	1	
16	18047	CHASSIS (WBH16EF).....	1.....	S/N 1P01 AND BELOW USED UP TO JAN. 31, 2023
16	522416	CHASSIS (WBH16EF).....	1.....	S/N 1P02 AND ABOVE EFFECTIVE FEB. 2023
18	492586	NUT, NYLOC 5/8"-11	2	
19	492597	WASHER, FLAT 9.5 X 22.2	3	
20	18162	PANEL, REAR WHEEL COVER	1	
21	18222	PLATFORM, OPERATOR	1	
22	492313	SCREW, HHC 3/8"-16 X 1-1/2"	1	
23	492406	SCREW, HHC 5/8"-11 X 1-1/2"	2	
24	492363	SCREW, HHC 5/16"-18 X 3/4"	3	
27	2105164	NUT, 5/16".....	3.....	REPLACES P/N 492553
28	18173	LATCH, PLATFORM	1	

HANDLE/FOOT DUMP CONTROLS ASSY.

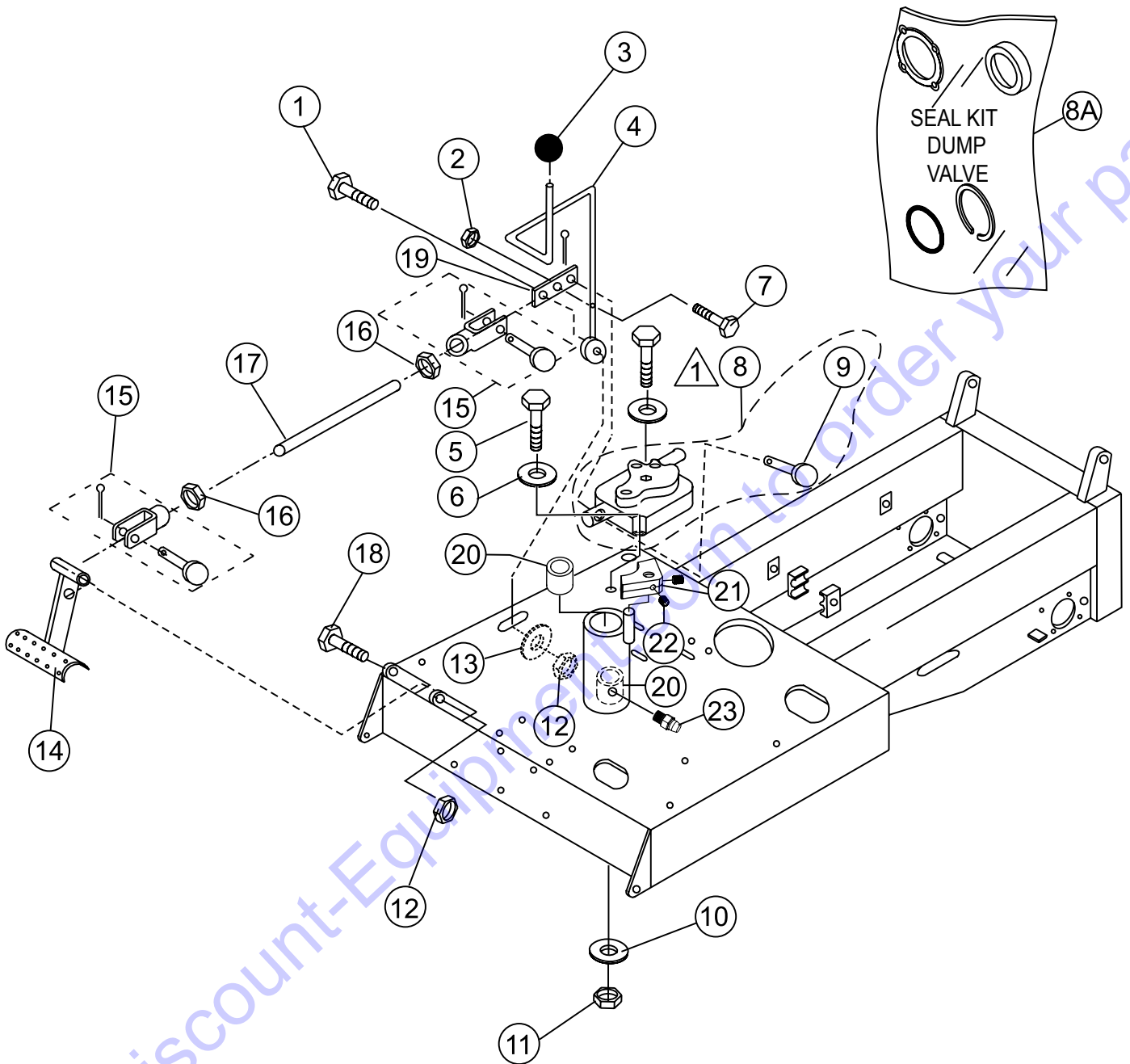

1 REFERENCE HYDRAULIC
DUMP ASSY.

HANDLE/FOOT DUMP CONTROLS ASSY.

<u>NO.</u>	<u>PART NO.</u>	<u>PART NAME</u>	<u>QTY.</u>	<u>REMARKS</u>
1	492401	SCREW, HHC 1/2"-13 X 4	1	
2	503119	NUT, NYLOC 3/16"	1	
3	18121	KNOB, LEVER	1	
4	18065	LEVER, DUMP VALVE	1	
5	512185	SCREW, HHC 1/4"-20 X 1-3/4"	2	
6	492622	WASHER, FLAT 1/4"	4	
7	512183	SCREW, HHC 3/16"-24 X 1-1/4"	1	
8	18064	VALVE, DUMP	1	INCLUDES ITEMS W/\$
8A	18064SK	SEAL KIT, DUMP VALVE	1	
9\$		PIN, DUMP VALVE CROSS.....	1	NOT SOLD SEPARATELY
10	492596	WASHER, FLAT 1/4"	1	
11	492581	NUT, NYLOC 1/4"-20	1	
12	492584	NUT, NYLOC 1/2"-13	2	
13	492600	WASHER, FLAT 1/2"	1	
14	18152	PEDAL, DUMP VALVE	1	
15	18123	CLEVIS ASSY., DUMP VALVE	2	
16	492574	NUT, HEX 3/8"	2	
17	18153	ROD, DUMP VALVE	1	
18	492400	SCREW, HHC 1/2"-13 X 3-1/2"	1	
19	18122	BELL CRANK, DUMP VALVE	1	
20	512200	BUSHING, BRONZE	2	
21	803151	STOP, STEERING	1	
22	492467	SET SCREW, 5/16" X 3/8" NC	2	
23	503901	ZERK FITTING 1/4"-28	1	

HYDRAULIC OIL TANK ASSY.

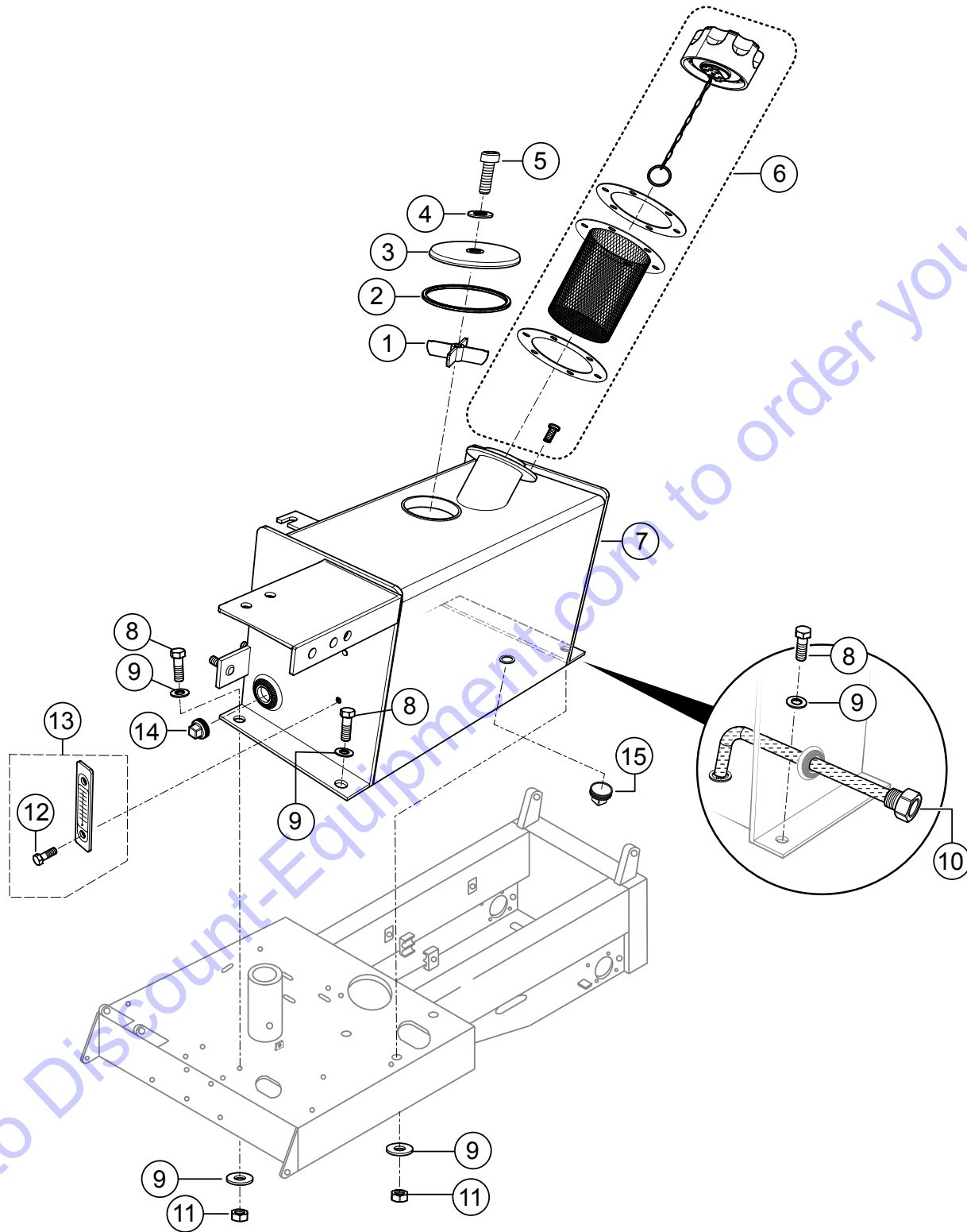

HYDRAULIC OIL TANK ASSY.

<u>NO.</u>	<u>PART NO.</u>	<u>PART NAME</u>	<u>QTY.</u>	<u>REMARKS</u>
1	520461	RETAINER	1	
2	801791	O-RING	1	
3	520460	COVER	1	
4	520343	O-RING	1	
5	510717	BOLT, 1/2" X 1-3/4" NC	1	
6	EM16477	CAP, HYDRAULIC OIL TANK	1	
7	18125	TANK, HYDRAULIC OIL	1	
8	492376	SCREW, HHC 3/8" X 1-1/4"	3	
9	492598	WASHER, FLAT 3/8"	6	
10	18229	SCREEN, OIL RESERVOIR	1	
11	492583	NUT, NYLOC 3/8"-16	3	
12%		SCREW,.....	2	NOT SOLD SEPARATELY
13	18052	SIGHT GAUGE, HYD. OIL TANK.....	1	INCLUDES ITEMS W/%
14	491213	PLUG, HYD. OIL TANK 3/4"-14 NPT	1	
15	506094	PLUG, HYD. OIL TANK 1/2" NPT	1	

BATTERY ASSY.

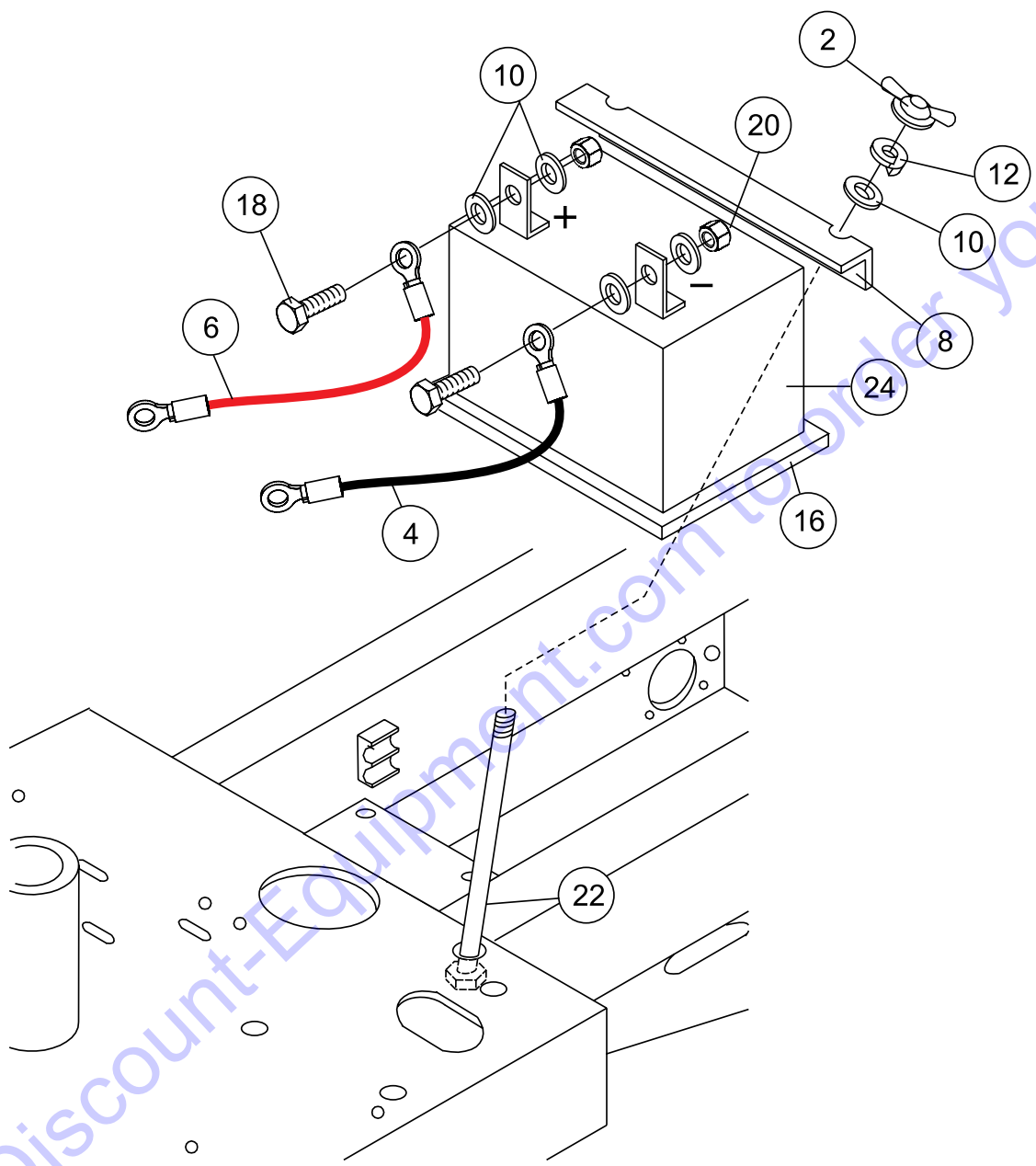

BATTERY ASSY.

<u>NO.</u>	<u>PART NO.</u>	<u>PART NAME</u>	<u>QTY.</u>	<u>REMARKS</u>
2	505500	WING NUT	2	
4	512557	BATTERY CABLE, NEGATIVE	1	
6	511250	BATTERY CABLE, POSITIVE	1	
8	512555	BATTERY SUPPORT BRACKET	1	
10	EM92305	WASHER, FLAT 1/4".....	6.....	REPLACES P/N 492596
12	2101402	WASHER, LOCK 1/4"	2.....	REPLACES P/N 492622
16	508480	BATTERY SUPPORT PLATFORM	1	
18	492357	BOLT, 3/16" X 1"	2	
20	503119	NUT, 3/16"	2	
22	512585	SUPPORT BRACKET BOLT	2	
24	4671	BATTERY	1	

Go to Discount-Equipment.com to order your parts

FUEL TANK ASSY. (STEEL)

NOTICE

Beginning year 2012 with evaporative system.

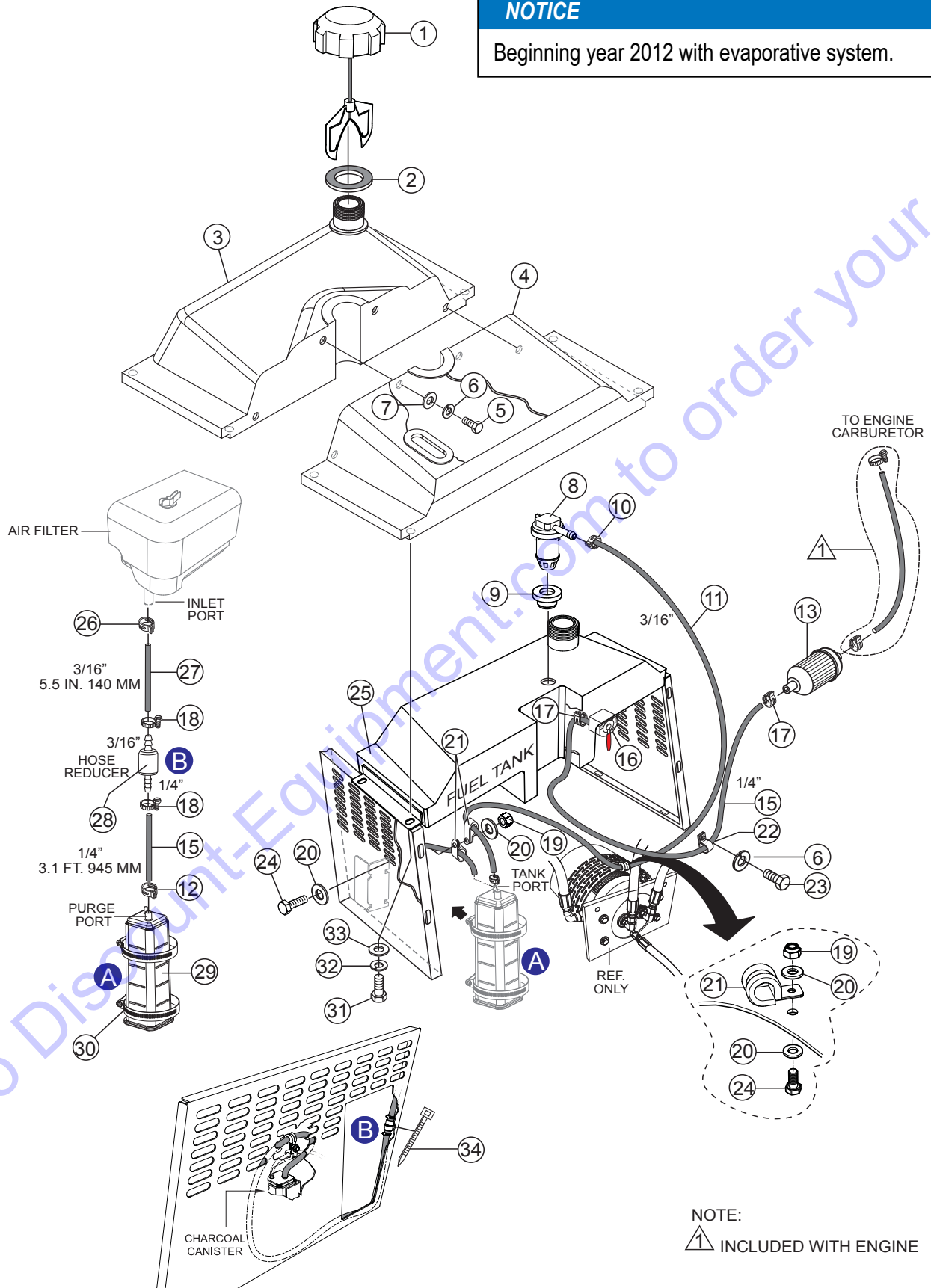

FUEL TANK ASSY. (STEEL)

<u>NO.</u>	<u>PART NO.</u>	<u>PART NAME</u>	<u>QTY.</u>	<u>REMARKS</u>
1	520820	CAP, FUEL (EPA) 2" DIA.	1	
2	802006	FUEL TANK NECK SEAL	1	
3	800845	COVER, FUEL TANK, FRONT, PLASTIC	1	
4	521392	COVER, FUEL TANK, REAR, PLASTIC	1	
5	492356	SCREW, 1/4" X 3/4" GRD 5	4	
6	492622	WASHER, LOCK 1/4"	4	
7	509161	WASHER, FLAT 5/16"	4	
8	202772	VENT VALVE, EPA	1	
9	203403	GROMMET, VENT VALVE	1	
10	802498	TENSION CLAMP	1	
11	60004	HOSE, FUEL, Ø.1875, LOW PERM 50PSI 41"	1	
12	802573	TENSION CLAMP	1	
13	EM20763	FILTER, IN-LINE FUEL	1	
15	520611	HOSE, FUEL, 1/4" EPA (3.1 FT.)	4	1PC=1FT
16	22081	VALVE, FUEL SHUT-OFF	1	
17	802574	TENSION CLAMP	1	
18	506208	CLAMP, FUEL HOSE	3	
19	492581	NUT, NYLOC 1/4"	2	
20	492595	WASHER, FLAT 1/4"	2	
21	801130	CLAMP, RUBBER COATED	3	
22	511807	CLAMP NYLON 5/8"	1	
23	492355	SCREW, 1/4" NC X 1/2" GRD 5	1	
24	800056	BOLT, HHCC 1/4" NC X 3/4" GRD 5	2	
25	800841	TANK, FUEL, STEEL	1	
26	802498	TENSION CLAMP	3	
27	520833	HOSE, AIR FILTER 3/16" (5.5") EPA	1	1PC=1FT
28	802405	HOSE REDUCER, 1/4" TO 3/16"	1	
29	23505	CANISTER, CHARCOAL, 390CC (EPA)	1	
30	510725	CLAMP	2	
31	492363	SCREW, 5/16" X 3/4" GRD 5	6	
32	EM923343	WASHER, LOCK 5/16"	8	REPLACES P/N 492623
33	EM923023	WASHER, FLAT 5/16"	8	REPLACES P/N 492597
34	491030	PLASTIC TIE WRAP	1	

FUEL TANK ASSY. (PLASTIC)

<u>NO.</u>	<u>PART NO.</u>	<u>PART NAME</u>	<u>QTY.</u>	<u>REMARKS</u>
1	EM923343	WASHER, LOCK 5/16"	4	
2	EM492299	SCREW, HHC 5/16"-18 X 1/2"	4	
3	EM923023	WASHER, FLAT 5/16"	4	
5	18166	CAP, FUEL 4" DIA.	1	
7	506208	CLAMP, FUEL HOSE	4	
9	19633	SEAL, FUEL TANK GROMMET	1	
10	20795	VALVE, FUEL SHUT-OFF	1	
11	512192	HOSE, FUEL	1	
12	EM20763	FILTER, FUEL	2	
13	512191	HOSE, FUEL	1	
14	511807	STRAP, NYLON 5/8"	1	
15	18103	COVER, FUEL TANK	1	
16	18098	TANK, PLASTIC FUEL	1	

ENGINE MOUNTING ASSY.

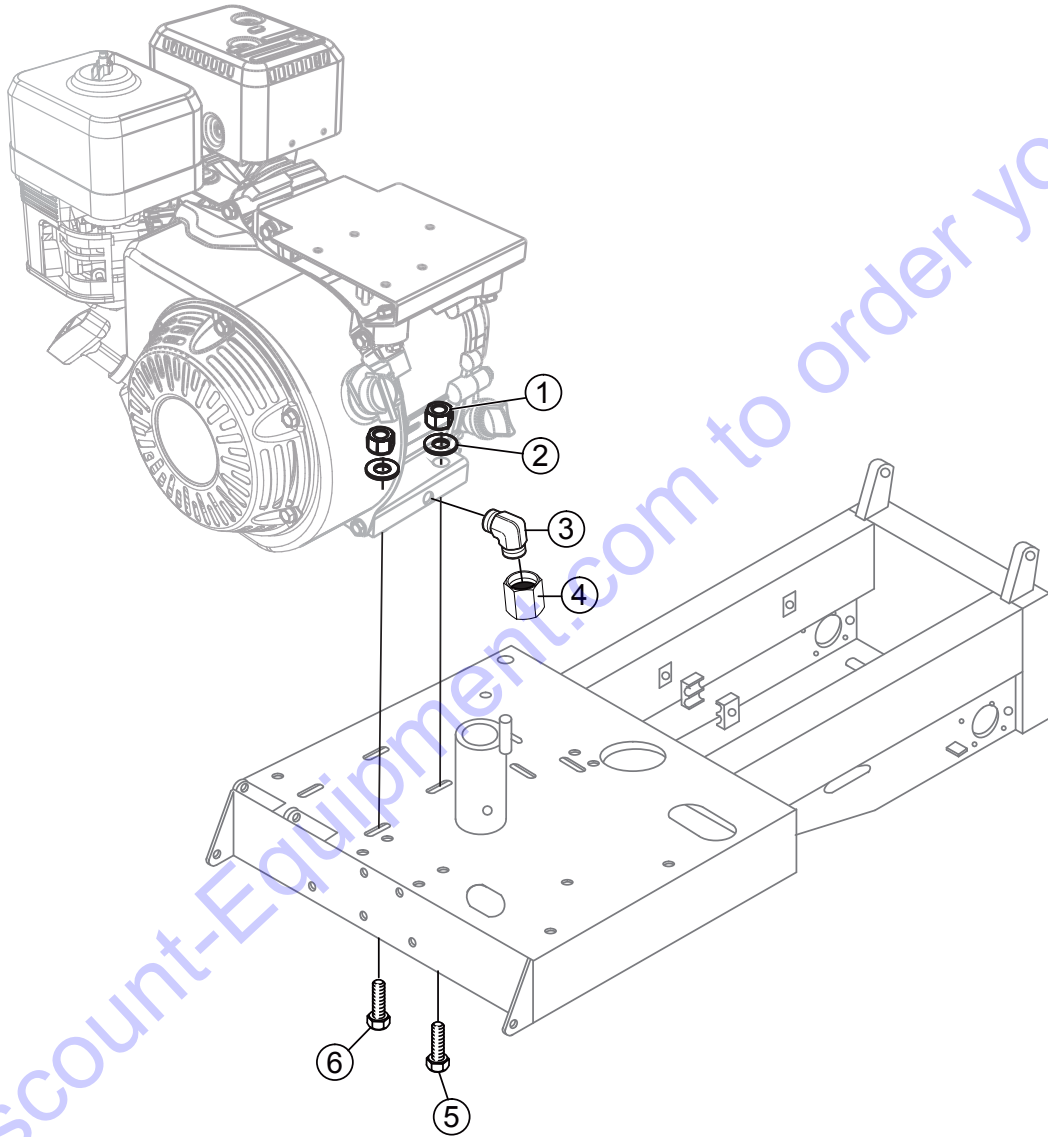

ENGINE MOUNTING ASSY.

<u>NO.</u>	<u>PART NO.</u>	<u>PART NAME</u>	<u>QTY.</u>	<u>REMARKS</u>
1	2105164	NUT, NYLOC 5/16"	4.....	REPLACES P/N 492582
2	505679	WASHER, FLAT 3/8"	4	
3	513593	90° FITTING	1	
4	513594	ADAPTER PLUG	1	
5	492368	SCREW, 5/16" NC X 2" GRD 5.....	1.....	GROUND CONNECTION
6	492367	SCREW, 5/16" NC X 1-3/4" GRD 5	3	

Go to Discount-Equipment.com to order your parts

ENGINE ASSY.

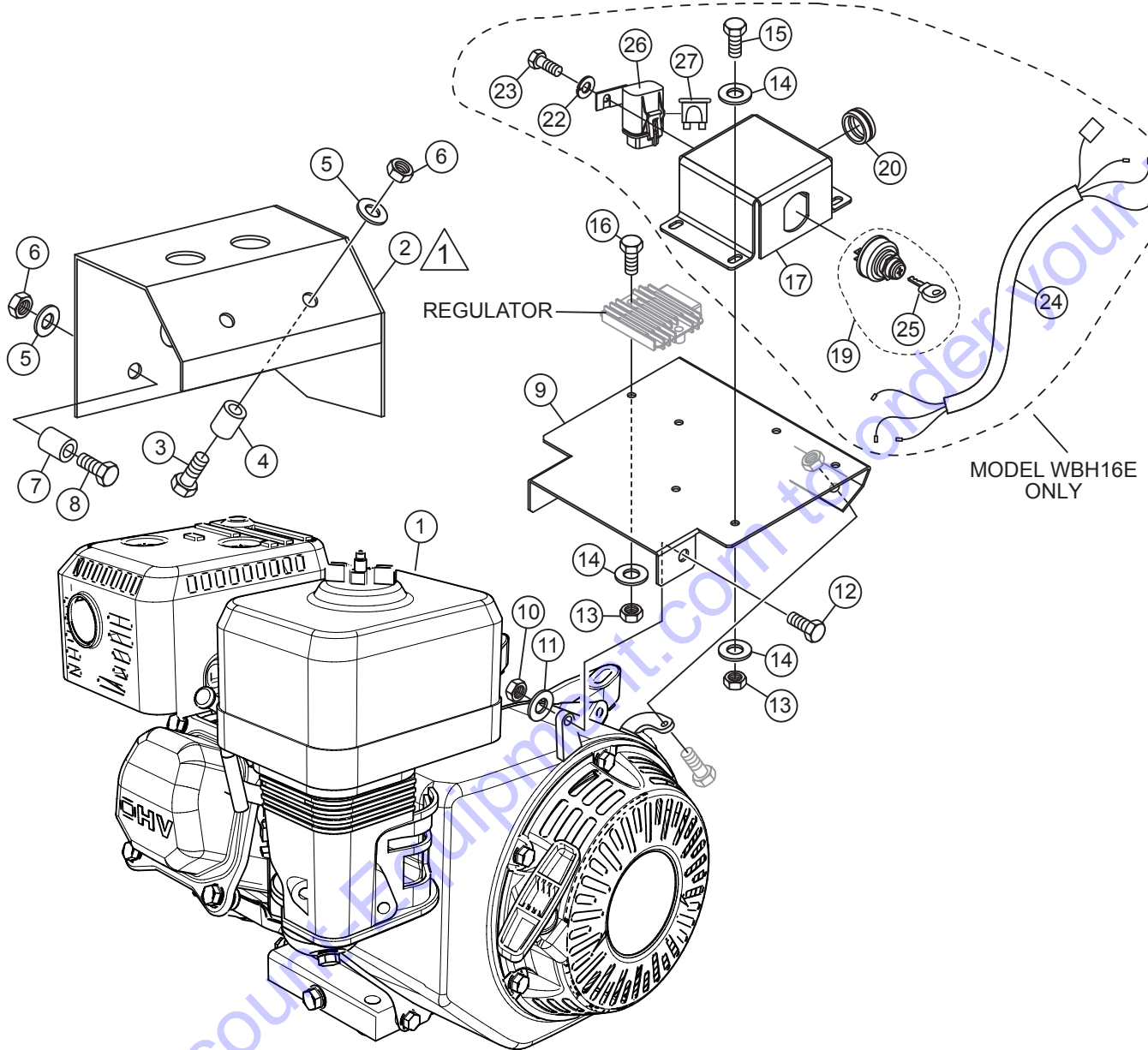

NOTES:



MUFFLER GUARD AND ASSOCIATED HARDWARE ARE NO LONGER AVAILABLE. REF. PANEL ASSY., ITEM 15 FOR REPLACEMENT MUFFLER GUARD.

ENGINE ASSY.

<u>NO.</u>	<u>PART NO.</u>	<u>PART NAME</u>	<u>QTY.</u>	<u>REMARKS</u>
1	520767	ENGINE, HONDA 11 HP RECOIL START	1.....	WBH16/WBH16F ONLY
1	520766	ENGINE, HONDA 11 HP ELECTRIC START.....	1.....	WBH16E/WBH16EF ONLY
2	801029	GUARD, MUFFLER.....	1.....	NO LONGER AVAILABLE
3	503118	BOLT, 3/16" X 1" NC GRD 2	2	
4	512512	SPACER	2	
5	492595	WASHER, FLAT 3/16"	4	
6	503119	NUT, 3/16" NC	4	
7	512507	SPACER	2	
8	508998	BOLT, 3/16" X 1-1/2" NC	2	
9	18007	MOTOR COVER	1	
10	492583	NUT, 3/8" NC	2	
11	492598	WASHER 3/8"	2	
12	EM963057	CAP SCREW 3/8" X 1-1/2"	2.....	REPLACES P/N 492313
13	492581	NUT, 1/4" NC	6	
14	492596	WASHER, FLAT 1/4".....	10.....	WBH16E ONLY
15	492356	BOLT, 1/4" X 3/4" NC GRD 5.....	4.....	WBH16E ONLY
16	EM492358	BOLT, 1/4" X 1-1/4" NC GRD 5	2	
17	801019	IGNITION SWITCH BOX	1.....	WBH16E ONLY
19	10958	IGNITION SWITCH.....	1.....	INCLUDES ITEMS W/# WBH16E ONLY
20	800921	GROMMET	1.....	WBH16E ONLY
22	492621	WASHER, LOCK 3/16"	1.....	WBH16E ONLY
23	EM503115	SCREW.....	1.....	WBH16E ONLY
24	801014	ELECTRICAL HARNESS.....	1.....	WBH16E ONLY
25#	11078	KEY, IGNITION SWITCH	1.....	WBH16E ONLY
26	EM98066	FUSE HOLDER	1.....	WBH16E ONLY
27	EM98287	FUSE, 25 AMP.....	1.....	WBH16E ONLY

ENGINE SERVICE PARTS

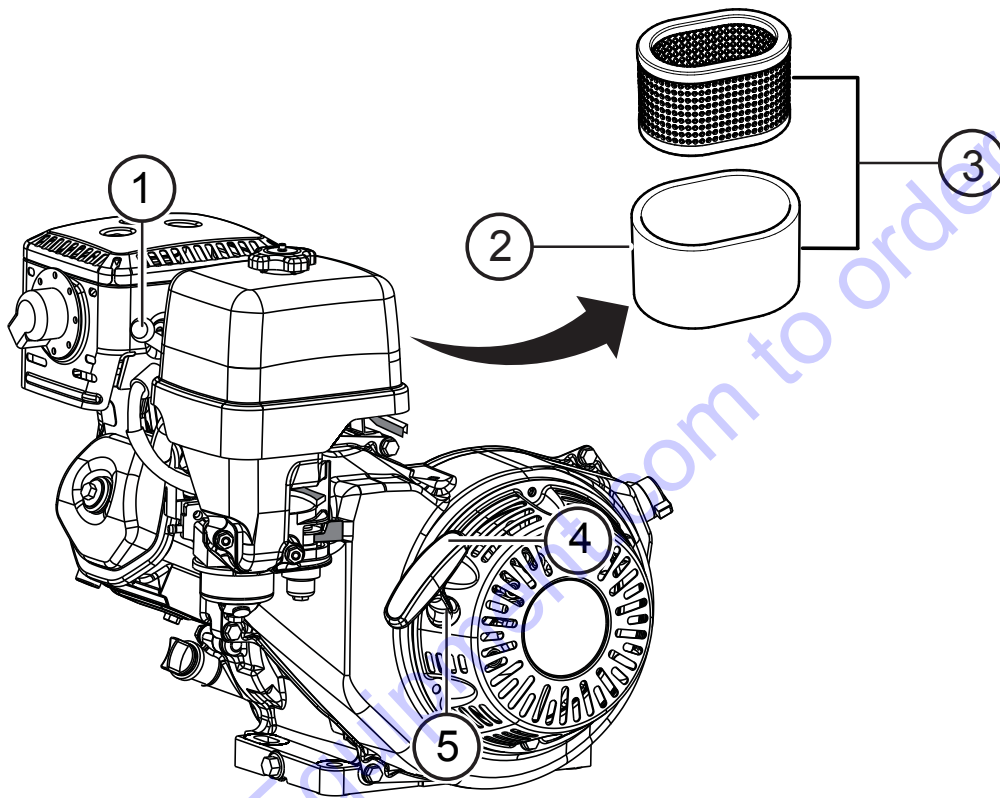

ENGINE SERVICE PARTS

<u>NO.</u>	<u>PART NO.</u>	<u>PART NAME</u>	<u>QTY.</u>	<u>REMARKS</u>
1	9807955846	SPARK PLUG	1	
2#	17218ZE3505	AIR FILTER, OUTER	1	
3	17210ZE3505	AIR FILTER, ELEM. (DUAL)	1.....	INCLUDES ITEMS W/#
4	28461Z5T305	GRIP, RECOIL STARTER	1	
5	28400Z5T003ZA	ROPE, RECOIL STARTER (RED)	1	
5	28400Z5T305ZB	ROPE, RECOIL STARTER (BLACK)	1	

Go to Discount-Equipment.com to order your parts

PARTS FINDER

**Search Website
by Part Number**



**Search Manual
Library For Parts
Manual & Lookup Part
Numbers – Purchase
or Request Quote**

Search Manuals

Enter your information to help us find the right parts manual for your machine.

* Brand:

* Model:

* Serial:

* Part Number:

SEARCH

**Can't Find Part or
Manual? Request Help
by Manufacturer,
Model & Description**

Parts Order Form

Please fill in the following information to help us find the right part for your machine.

Manufacturer:	<input type="text"/>
Model:	<input type="text"/>
Description:	<input type="text"/>
Part Number:	<input type="text"/>
Quantity:	<input type="text"/>
Notes:	<input type="text"/>

Submit

Discount-Equipment.com is your online resource for quality parts & equipment.

Florida: **561-964-4949** Outside Florida TOLL FREE: **877-690-3101**

Need parts?

Click on this link: <http://www.discount-equipment.com/category/5443-parts/> and choose one of the options to help get the right parts and equipment you are looking for. Please have the machine model and serial number available in order to help us get you the correct parts. If you don't find the part on the website or on one of the online manuals, please fill out the request form and one of our experienced staff members will get back to you with a quote for the right part that your machine needs.

We sell worldwide for the brands: Genie, Terex, JLG, MultiQuip, Mikasa, Essick, Whiteman, Mayco, Toro Stone, Diamond Products, Generac Magnum, Airman, Haulotte, Barreto, Power Blanket, Nifty Lift, Atlas Copco, Chicago Pneumatic, Allmand, Miller Curber, Skyjack, Lull, Skytrak, Tsurumi, Husquvarna Target, Stow, Wacker, Sakai, Mi-T-M, Sullair, Basic, Dynapac, MBW, Weber, Bartell, Bennar Newman, Haulotte, Ditch Runner, Menegotti, Morrison, Contec, Buddy, Crown, Edco, Wyco, Bomag, Laymor, EZ Trench, Bil-Jax, F.S. Curtis, Gehl Pavers, Heli, Honda, ICS/PowerGrit, IHI, Partner, Imer, Clipper, MMD, Koshin, Rice, CH&E, General Equipment, Amida, Coleman, NAC, Gradall, Square Shooter, Kent, Stanley, Tamco, Toku, Hatz, Kohler, Robin, Wisconsin, Northrock, Oztec, Toker TK, Rol-Air, APT, Wylie, Ingersoll Rand / Doosan, Innovatech, Con X, Ammann, Mecalac, Makinex, Smith Surface Prep, Small Line, Wanco, Yanmar

PARTS MANUAL

HERE'S HOW TO GET HELP

PLEASE HAVE THE MODEL AND SERIAL
NUMBER ON-HAND WHEN CALLING



www.discount-equipment.com

© COPYRIGHT 2023, MULTIQUIP INC.

Multiquip Inc, the MQ logo are registered trademarks of Multiquip Inc. and may not be used, reproduced, or altered without written permission. All other trademarks are the property of their respective owners and used with permission.

This manual MUST accompany the equipment at all times. This manual is considered a permanent part of the equipment and should remain with the unit if resold.

The information and specifications included in this publication were in effect at the time of approval for printing. Illustrations, descriptions, references and technical data contained in this manual are for guidance only and may not be considered as binding. Multiquip Inc. reserves the right to discontinue or change specifications, design or the information published in this publication at any time without notice and without incurring any obligations.

