

# OPERATION MANUAL



**WHISPERWATT™ SERIES**  
**MODEL DCA20SPXU4F**  
**60 Hz GENERATOR**  
**(ISUZU 4LE2T DIESEL ENGINE)**  
**INSTRUCTION MANUAL NO. M1844300324C**

Revision #6 (09/07/22)



THIS MANUAL MUST ACCOMPANY THE EQUIPMENT AT ALL TIMES.

**TO PURCHASE THIS PRODUCT PLEASE CONTACT US**



**Equipment Financing and  
Extended Warranties Available**



**Discount-Equipment.com is your online resource for  
commercial and industrial quality parts and equipment sales.**

**561-964-4949**

**visit us on line @ [www.discount-equipment.com](http://www.discount-equipment.com)**

Select an option below to find your Equipment

**Search by Manufacturer**

**Search by Product Type**

**Request a Quote**

We sell worldwide for the brands: Genie, Terex, JLG, MultiQuip, Mikasa, Essick, Whiteman, Mayco, Toro Stone, Diamond Products, Generac Magnum, Airman, Haulotte, Barreto, Power Blanket, Nifty Lift, Atlas Copco, Chicago Pneumatic, Allmand, Miller Curber, Skyjack, Lull, Skytrak, Tsurumi, Husquvarna Target, Stow, Wacker, Sakai, Mi-T-M, Sullair, Basic, Dynapac, MBW, Weber, Bartell, Bennar Newman, Haulotte, Ditch Runner, Menegotti, Morrison, Contec, Buddy, Crown, Edco, Wyco, Bomag, Laymor, EZ Trench, Bil-Jax, F.S. Curtis, Gehl Pavers, Heli, Honda, ICS/PowerGrit, IHI, Partner, Imer, Clipper, MMD, Koshin, Rice, CH&E, General Equipment, Amida, Coleman, NAC, Gradall, Square Shooter, Kent, Stanley, Tamco, Toku, Hatz, Kohler, Robin, Wisconsin, Northrock, Oztec, Toker TK, Rol-Air, APT, Wylie, Ingersoll Rand / Doosan, Innovatech, Con X, Ammann, Mecalac, Makinex, Smith Surface Prep, Small Line, Wanco, Yanmar

**PROPOSITION 65 WARNING**

---



To order go to Discount-Equipment.com

**DCA20SPXU4F  
60 Hz Generator**

Proposition 65 Warning ..... 2  
Table of Contents..... 3  
Safety Decals ..... 4  
Safety Information ..... 5–10  
Specifications ..... 11  
Dimensions..... 12  
Installation ..... 14–15  
General Information..... 16  
Major Components ..... 17  
Engine/Generator Control Panel..... 18–19  
Output Terminal Panel Familiarization ..... 20–22  
Load Application ..... 23  
AC Ammeter Gauge Reading..... 24  
Output Terminal Panel Connections ..... 25  
Inspection/Setup..... 26–30  
Generator Start-Up Procedure (Manual) ..... 31–33  
Generator Start-Up Procedure (Auto Mode)..... 34  
Generator Shutdown Procedures ..... 35  
Maintenance ..... 36–46  
Troubleshooting (Diagnostics) ..... 47  
Troubleshooting (Generator)..... 48  
Troubleshooting (Engine)..... 49–50  
Generator Wiring Diagram (M1814000603B) ..... 51  
Engine Wiring Diagram (M1814100723) ..... 52  
Controller Wiring Diagram (M1814100803C) ..... 53  
Battery Charger Wiring Diagram (Option) ..... 54  
Engine Block Heater Wiring Diagram (Option) ..... 55

**NOTICE**

Specifications are subject to change without notice.

# SAFETY DECALS

Safety decals are attached to the generator as shown in Figure 1. Keep these safety decals clean at all times. When the safety decals become worn or damaged, contact Discount-equipment.

**NOTICE**  
For safety decal part numbers, refer to the associated parts manual.

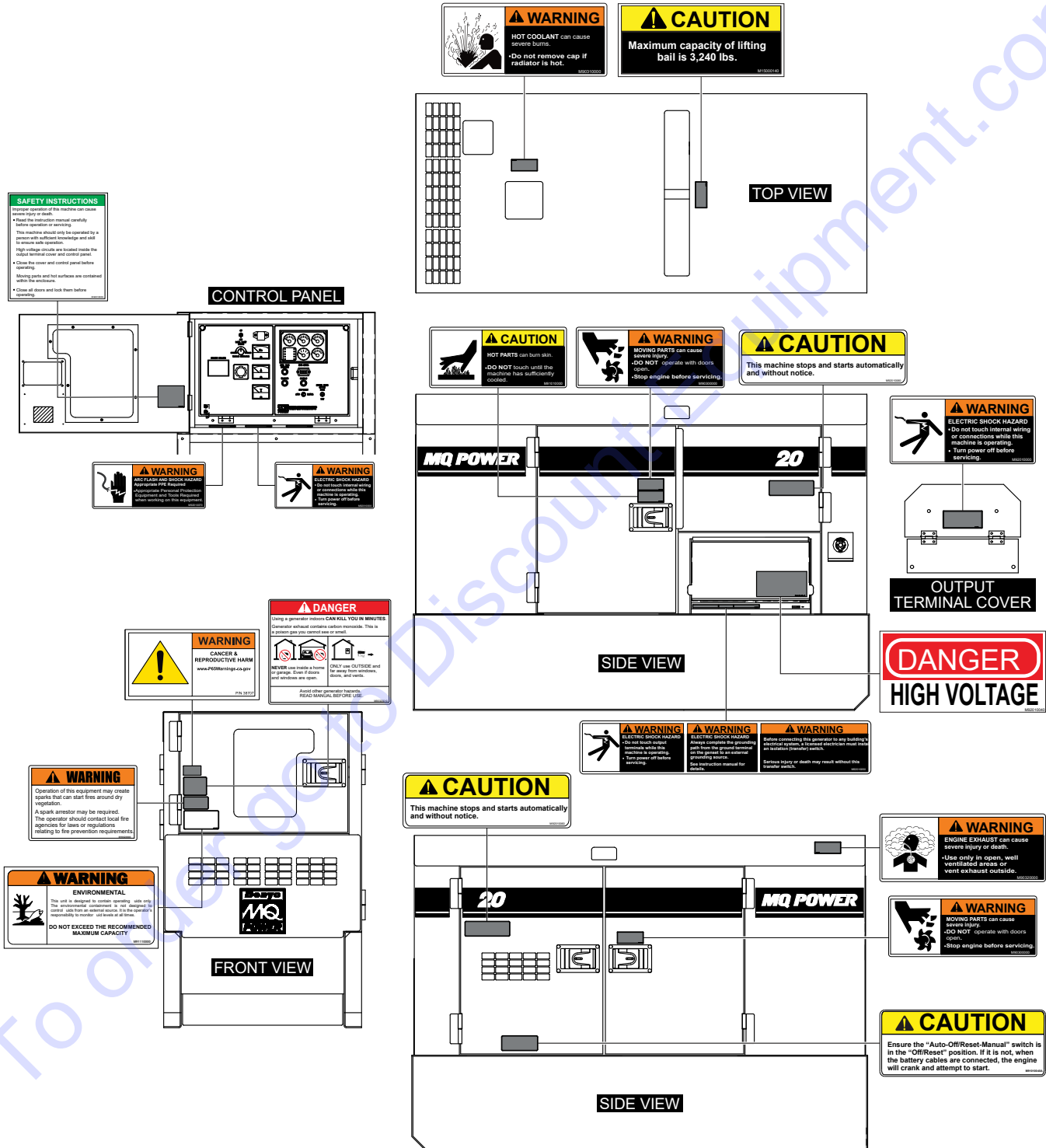

Figure 1. Safety Decals

# SAFETY INFORMATION

Do not operate or service the generator before reading the entire manual. Safety precautions should be followed at all times when operating this generator. Failure to read and understand the safety messages and operating instructions could result in injury to yourself and others.

## SAFETY MESSAGES

The four safety messages shown below will inform you about potential hazards that could injure you or others. The safety messages specifically address the level of exposure to the operator and are preceded by one of four words: **DANGER**, **WARNING**, **CAUTION** or **NOTICE**.

## SAFETY SYMBOLS

 **DANGER**

Indicates a hazardous situation which, if not avoided, **WILL** result in **DEATH** or **SERIOUS INJURY**.

 **WARNING**

Indicates a hazardous situation which, if not avoided, **COULD** result in **DEATH** or **SERIOUS INJURY**.







 **CAUTION**

Indicates a hazardous situation which, if not avoided, **COULD** result in **MINOR** or **MODERATE INJURY**.

**NOTICE**

Addresses practices not related to personal injury.

Potential hazards associated with the operation of this generator will be referenced with hazard symbols which may appear throughout this manual in conjunction with safety messages.

Symbol	Safety Hazard
	Lethal exhaust gas hazards
	Explosive fuel hazards
	Burn hazards
	Overspeed hazards
	Rotating parts hazards
	Pressurized fluid hazards
	Electric shock hazards

# SAFETY INFORMATION

## GENERAL SAFETY

### CAUTION

- **NEVER** operate this generator without proper protective clothing, shatterproof glasses, respiratory protection, hearing protection, steel-toed boots and other protective devices required by the job or city and state regulations.





- **NEVER** operate this generator when not feeling well due to fatigue or illness, or when on medication. 
- **NEVER** operate this generator under the influence of drugs or alcohol.



- **ALWAYS** check the generator for loosened threads or bolts before starting.
- **NEVER** use the generator for any purpose other than its intended purposes or applications.

### NOTICE

- This generator should only be operated by trained and qualified personnel 18 years of age and older.
- Whenever necessary, replace nameplate, operation and safety decals when they become difficult to read.
- Manufacturer does not assume responsibility for any accident due to equipment modifications. Unauthorized modification of the generator will void all warranties.
- **NEVER** use accessories or attachments that are not recommended by MQ Power for this generator. Damage to the generator and/or injury to the user may result.
- **ALWAYS** know the location of the nearest fire extinguisher. 
- **ALWAYS** know the location of the nearest first aid kit. 

- **ALWAYS** know the location of the nearest phone or **keep a phone on the job site**. Also, know the phone numbers of the nearest **ambulance, doctor, and fire department**. This information will be invaluable in the case of an emergency.



## GENERATOR SAFETY

### DANGER

- **NEVER** operate the generator in an explosive atmosphere or near combustible materials. An explosion or fire could result causing **severe bodily harm or even death**. 

### WARNING

- **NEVER** disconnect any **emergency or safety devices**. These devices are intended for operator safety. Disconnection of these devices can cause **severe injury, bodily harm or even death**. Disconnection of any of these devices will void all warranties.

### CAUTION

- **NEVER** lubricate components or attempt service on a **running generator**.

### NOTICE

- **ALWAYS** ensure the generator is on level ground before use.
- **ALWAYS** keep the generator in proper running condition.
- Fix damage to the generator and replace any broken parts immediately.
- **ALWAYS** store the generator properly when it is not being used. The generator should be stored in a clean, dry location out of the reach of children and unauthorized personnel.

# SAFETY INFORMATION

## ENGINE SAFETY

### DANGER

- The engine fuel exhaust gases contain poisonous carbon monoxide. This gas is colorless and odorless, and can cause **death** if inhaled.
- The engine of this generator requires an adequate, free flow of cooling air. **NEVER** operate this equipment in any enclosed or narrow area where free flow of the air is restricted. If the air flow is restricted it will cause injury to people and property and serious damage to the equipment or engine.



- When operating the generator outdoors, **DO NOT** place the generator near doors, windows or vents that could allow carbon monoxide to enter and build up in occupied spaces.

### WARNING

- **NEVER** place hands or fingers inside the engine compartment when the engine is running.
- **NEVER** operate the engine with heat shields or guards removed.
- Keep fingers, hands, hair and clothing away from all moving parts to prevent injury.
- **NEVER** operate the generator with the doors open. Stop the engine before servicing.
- **DO NOT** remove the radiator cap while the engine is hot. High pressure boiling water will gush out of the radiator and severely scald any persons in the general area of the generator.
- **DO NOT** remove the coolant drain plug while the engine is hot. Hot coolant will gush out of the coolant tank and severely scald any persons in the general area of the generator.
- **DO NOT** drain the engine oil while the engine is hot. Hot oil will gush out and severely scald any persons near the generator.



- Operation of the generator may create sparks that can start fires around dry vegetation. A spark arrestor may be required. The operator should contact local fire agencies for laws or regulations relating to fire prevention requirements.

### CAUTION

- **NEVER** touch the hot exhaust manifold, muffler or cylinder. Allow these parts to cool before servicing the generator.



### NOTICE

- **NEVER** run the engine without an air filter or with a dirty air filter. Severe engine damage may occur. Service the air filter frequently to prevent engine malfunction.
- **NEVER** tamper with the factory settings of the engine or engine governor. Damage to the engine or generator can result if operating in speed ranges above the maximum allowable.



- Wet stacking is a common problem with diesel engines which are operated for extended periods with light or no load applied. When a diesel engine operates without sufficient load (less than 30-35% of the rated output), it will not operate at its optimum temperature. This will allow unburned fuel to accumulate in the exhaust system, which can foul the fuel injectors, engine valves and exhaust system, including turbochargers, and reduce the operating performance.

In order for a diesel engine to operate at peak efficiency, it must be able to provide fuel and air in the proper ratio and at a high enough engine temperature for the engine to completely burn all of the fuel.

Wet stacking does not usually cause any permanent damage and can be alleviated if additional load is applied to relieve the condition. It can reduce the system performance and increase maintenance. Applying an increasing load over a period of time until the excess fuel is burned off and the system capacity is reached usually can repair the condition. This can take several hours to burn off the accumulated unburned fuel.

# SAFETY INFORMATION

## FUEL SAFETY

### DANGER

- **NEVER** start the engine near spilled fuel or combustible fluids. Diesel fuel is extremely flammable and its vapors can cause an explosion if ignited.
- **ALWAYS** refuel in a well-ventilated area, away from sparks and open flames.
- **ALWAYS** use extreme caution when working with **flammable** liquids.
- **NEVER** fill the fuel tank while the engine is **running** or **hot**.
- **NEVER** overfill the fuel tank. Spilled fuel can ignite if it comes into contact with hot engine parts or sparks from the ignition system.
- Store fuel in appropriate containers, in well-ventilated areas and away from sparks and flames.
- **NEVER** use fuel as a cleaning agent.
- **NEVER** smoke around or near the equipment. Fire or explosion could result from fuel vapors or if fuel is spilled on a hot engine.



## TOWING SAFETY

### CAUTION

- Check with your local county or state safety towing regulations, in addition to meeting **Department of Transportation (DOT) Safety Towing Regulations**, before towing your generator.
- Refer to the MQ Power trailer manual for additional safety information.
- In order to reduce the possibility of an accident while transporting the generator on public roads, **ALWAYS** make sure that the trailer that supports the generator and the towing vehicle are both mechanically sound and in good operating condition.
- **ALWAYS** shut down the engine before transporting.



- Make sure the hitch and coupling of the towing vehicle are rated equal to or greater than the trailer **gross vehicle weight rating**.
- **ALWAYS** inspect the hitch and coupling for wear. **NEVER** tow a trailer with defective hitches, couplings, chains, etc.
- Check the tire air pressure on both the towing vehicle and the trailer. **Inflate trailer tires as indicated on side wall of tire**. Also check the tire tread wear on both vehicles.
- **ALWAYS** make sure the trailer is equipped with **safety chains**.
- **ALWAYS** properly attach the trailer's safety chains to the towing vehicle.
- **ALWAYS** make sure the vehicle and trailer directional, backup, brake, and trailer lights are connected and working properly.
- DOT requirements include the following:
  - Connect and test electric brake operation.
  - Secure portable power cables in cable tray with tie wraps.
- The maximum speed for highway towing is **55 MPH** unless posted otherwise. Recommended off-road towing is not to exceed **15 MPH** or less depending on the type of terrain.
- Avoid sudden stops and starts. These can cause skidding or jackknifing. Smooth, gradual starts and stops will improve towing.
- Avoid sharp turns to prevent rolling.
- The trailer should be adjusted to a level position at all times when towing.
- Raise and lock the trailer wheel stand in the upright position when towing.
- Place **chock blocks** underneath the wheels to prevent **rolling** while parked.
- Place **support blocks** underneath the trailer's bumper to prevent **tipping** while parked.
- Use the trailer's swivel jack to adjust the trailer height to a level position while parked.

# SAFETY INFORMATION

## ELECTRICAL SAFETY

### DANGER

- **NEVER** touch the output terminals during operation. Contact with the output terminals during operation can cause **electrocution, electrical shock, or burn**.



- The electrical voltage required to operate the generator can cause **severe injury or even death** through physical contact with live circuits. Turn the generator and all circuit breakers **OFF** before performing maintenance on the generator or making contact with the output terminals.

- **NEVER** insert any objects into the output receptacles during operation. This is extremely dangerous. The possibility exists of **electrical shock, electrocution or death**.



- Backfeed to a utility system can cause **electrocution** and/or property damage. **NEVER** connect the generator to a building's electrical system without a transfer switch or other approved device. All installations should be performed by a **licensed electrician** in accordance with all applicable laws and electrical codes. Failure to do so could result in electrical shock or burn, causing **serious injury or even death**.



## Power Cord/Cable Safety

### DANGER

- **NEVER** let power cords or cables **lay in water**.
- **NEVER** **stand in water** while AC power from the generator is being transferred to a load.
- **NEVER** use **damaged** or **worn** cables or cords when connecting equipment to the generator. Inspect the insulation for cuts.
- **NEVER** grab or touch a live power cord or cable with wet hands. The possibility exists of **electrical shock, electrocution or death**.

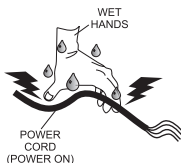

- Make sure power cables are securely connected to the generator's output receptacles. Incorrect connections may cause electrical shock and damage to the generator.

### NOTICE

- **ALWAYS** make certain that the proper power or extension cord has been selected for the job. See the Cable Selection Chart in this manual.

## Grounding Safety

### DANGER

- **ALWAYS** make sure that electrical circuits are properly grounded to a suitable earth ground (ground rod) per the National Electrical Code (NEC) and local codes before operating the generator. **Severe injury or death by electrocution** can result from operating an ungrounded generator.
- **NEVER** use gas piping as an electrical ground.

## BATTERY SAFETY

### DANGER

- **DO NOT** drop the battery. There is a possibility that the battery will explode.
- **NEVER** expose the battery to open flames, sparks, cigarettes, etc. The battery contains combustible gases and liquids. If these gases and liquids come into contact with a flame or spark, an explosion could occur.



### WARNING

- **ALWAYS** wear safety glasses when handling the battery to avoid eye irritation. The battery contains acids that can cause injury to the eyes and skin.
- Use well-insulated gloves when picking up the battery.
- **ALWAYS** keep the battery charged. If the battery is not charged, combustible gas will build up.
- **ALWAYS** recharge the battery in a well-ventilated environment to avoid the risk of a dangerous concentration of combustible gases.
- If the battery liquid (dilute sulfuric acid) comes into contact with **clothing or skin**, rinse skin or clothing immediately with plenty of water.



# SAFETY INFORMATION

- If the battery liquid (dilute sulfuric acid) comes into contact with **eyes**, rinse eyes immediately with plenty of water and contact the nearest doctor or hospital to seek medical attention.

## CAUTION

- **ALWAYS** disconnect the **NEGATIVE battery terminal** before performing service on the generator.
- **ALWAYS** keep battery cables in good working condition. Repair or replace all worn cables.

## ENVIRONMENTAL SAFETY/DECOMMISSIONING

### NOTICE

Decommissioning is a controlled process used to safely retire a piece of equipment that is no longer serviceable. If the equipment poses an unacceptable and unrepairable safety risk due to wear or damage or is no longer cost effective to maintain (beyond life-cycle reliability) and is to be decommissioned (demolition and dismantlement), be sure to follow the rules below:

- **NEVER** pour waste or oil directly onto the ground, down a drain, or into any water source.
- Contact your country's Department of Public Works or recycling agency in your area and arrange for proper disposal of any electrical components, waste or oil associated with this equipment.
- When the life cycle of this equipment is over, remove the battery and bring it to an appropriate facility for lead reclamation. Use safety precautions when handling batteries that contain sulfuric acid.
- When the life cycle of this equipment is over, it is recommended that the frame and all other metal parts be sent to a recycling center.



Metal recycling involves the collection of metal from discarded products and its transformation into raw materials to use in manufacturing a new product.

Recyclers and manufacturers alike promote the process of recycling metal. Using a metal recycling center promotes energy cost savings.

## EMISSIONS INFORMATION

### NOTICE

The diesel engine used in this equipment has been designed to reduce harmful levels of carbon monoxide (CO), hydrocarbons (HC), and nitrogen oxides (NOx) contained in diesel exhaust emissions.

This engine has been certified to meet US EPA evaporative emissions requirements in the installed configuration.

Attempting to modify or make adjustments to the engine emission system by unauthorized personnel without proper training could damage the equipment or create an unsafe condition.

Additionally, modifying the fuel system may adversely affect evaporative emissions, resulting in fines or other penalties.

### Emission Control Label

The emission control label is an integral part of the emission system and is strictly controlled by regulations.

The label must remain with the engine for its entire life.

If a replacement emission label is needed, please contact Discount-equipment.

# SPECIFICATIONS

**Table 1. Generator Specifications**

<b>Model</b>	DCA20SPXU4F
<b>Type</b>	Revolving field, self-ventilated, protected type synchronous generator
<b>Armature Connection</b>	Series
<b>Phase</b>	1
<b>Standby Output</b>	22.0 kW (27.5 kVA)
<b>Prime Output</b>	20 kW (25 kVA)
<b>Voltage (L-L/L-N)</b>	240/120
<b>Power Factor</b>	1.0
<b>Frequency</b>	60 Hz
<b>Speed</b>	1,800 rpm
<b>Aux. AC Power</b>	Single Phase, 60 Hz
<b>Aux. Voltage/Output</b>	4.8 kW (2.4 kW x 2)
<b>Dry Weight</b>	1,797 lb. (815 kg)
<b>Wet Weight</b>	2,137 lb. (969 kg)

**Table 2. Engine Specifications**

<b>Model</b>	Isuzu 4LE2T Tier 4 Final Certified	
<b>Type</b>	4-Cycle, water-cooled, direct injection, turbocharged and cooled EGR, DOC	
<b>No. of Cylinders</b>	4	
<b>Bore x Stroke</b>	3.35 in. x 3.78 in. (85 mm x 96 mm)	
<b>Displacement</b>	133 cu. in. (2.179 liters)	
<b>Rated Output</b>	33.5 hp at 1,800 rpm	
<b>Starting</b>	Electric	
<b>Coolant Capacity</b>	2.3 gal. (8.8 liters) <sup>1</sup>	
<b>Lube Oil Capacity</b>	2.8 gal. (10.5 liters) <sup>2</sup>	
<b>Lube Oil Type</b>	API service class CJ-4 or JASO DH-2	
<b>Fuel Type</b>	#2 Diesel Fuel (Ultra low sulfur diesel fuel only)	
<b>Fuel Leak Warning Capacity</b>	12.7 gal. (48 liters)	
<b>Fuel Tank Capacity</b>	41.7 gal. (158 liters)	
<b>Fuel Consumption</b>	1.62 gal. (6.12 L)/hr. at <b>full load</b>	1.26 gal. (4.77 L)/hr. at <b>3/4 load</b>
	0.94 gal. (3.57 L)/hr. at <b>1/2 load</b>	0.67 gal. (2.52 L)/hr. at <b>1/4 load</b>
<b>Exhaust Gas After-Treatment System</b>	DOC	
<b>Battery</b>	27 (CCA 0° F 525 A) x 1	

<sup>1</sup> Includes engine, radiator, reserve tank, and hoses

<sup>2</sup> Includes filters and filter hoses

# DIMENSIONS

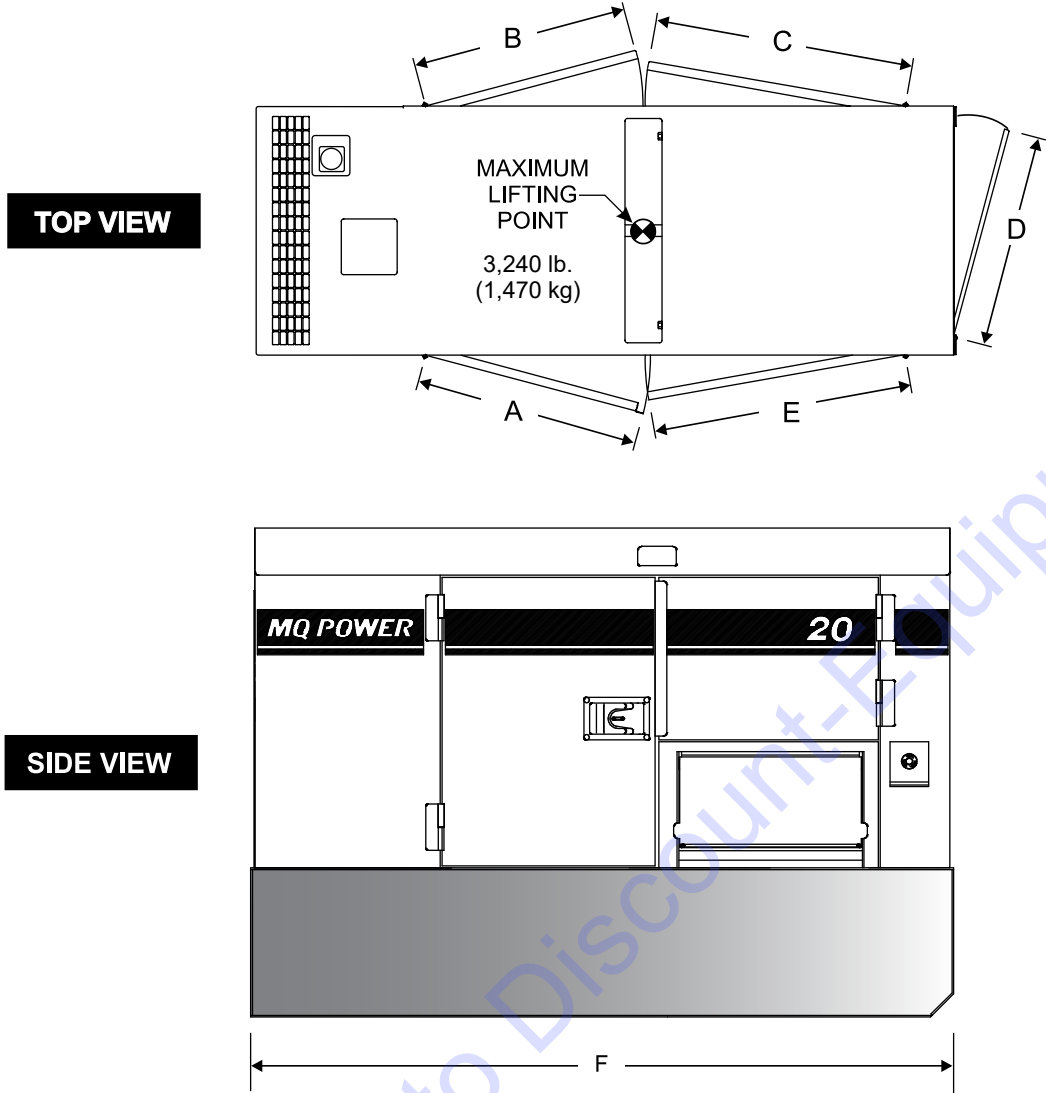

Figure 2. Dimensions

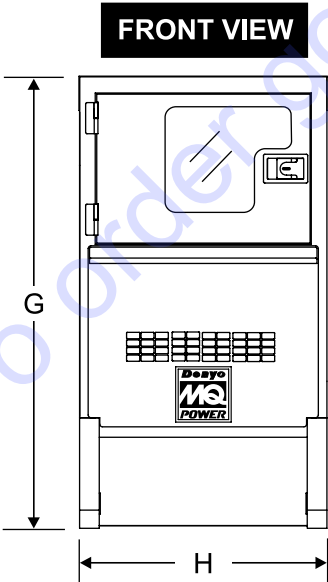

Table 3. Dimensions			
Reference Letter	Dimension in. (mm)	Reference Letter	Dimension in. (mm)
A	22.91 (582)	E	22.36 (568)
B	21.73 (552)	F	71.65 (1,820)
C	22.36 (568)	G	49.61 (1,260)
D	26.38 (670)	H	31.10 (790)

## GENERATOR GROUNDING

**ALWAYS** refer to Article 250 (Grounding and Bonding) of the National Electrical Code (NEC).

### NOTICE

**ALWAYS** check with state, province, district, and municipalities for electrical grounding requirements before using the generator.

**EXAMPLE** of how to ground the unit (Figure 3) if the condition of use requires such a device:

## Connecting The Ground

Consult with local electrical and safety codes for proper connection based on condition of use. Refer to the Conductor Grounding Table, Article 250 of the NEC handbook.

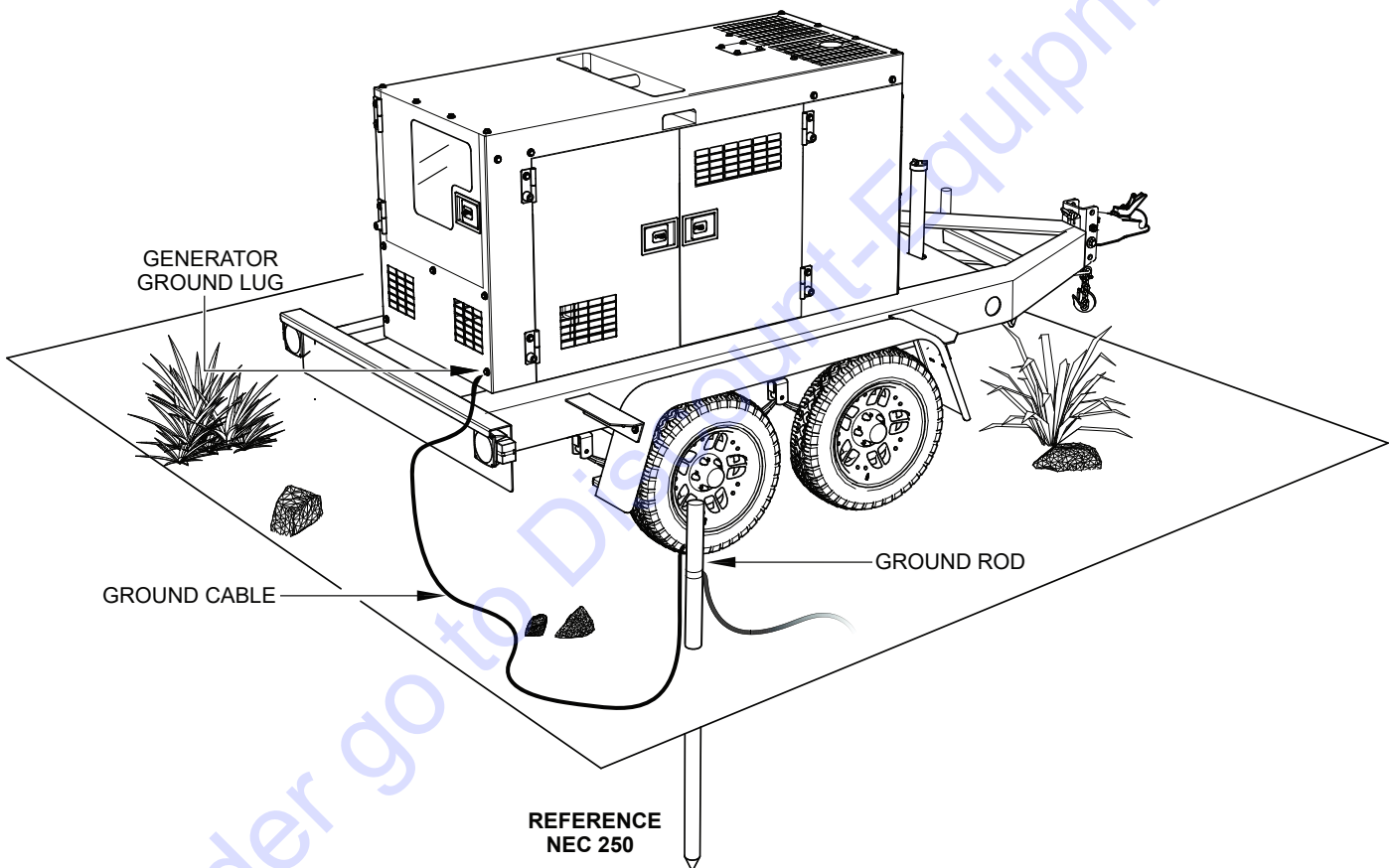

Figure 3. Typical Generator Grounding Application

### NOTICE

Trailer-mounted generators are the sole responsibility of MQ Power.

## OUTDOOR INSTALLATION

Install the generator in an area that is free of debris, bystanders, and overhead obstructions. Make sure the generator is on secure, level ground so that it cannot slide or shift around. Also, install the generator in a manner so that the exhaust will not be discharged in the direction of nearby homes.

The installation site must be relatively free from moisture and dust. All electrical equipment should be protected from excessive moisture. Failure to do so will result in deterioration of the insulation and will result in short circuits and grounding.

Foreign materials such as dust, sand, lint, and abrasive materials have a tendency to cause excessive wear to engine and alternator parts.

### CAUTION

Pay close attention to ventilation when operating the generator inside tunnels and caves. The engine exhaust contains noxious elements. Engine exhaust must be routed to a ventilated area.

## INDOOR INSTALLATION

Exhaust gases from diesel engines are extremely poisonous. Whenever an engine is installed indoors the exhaust fumes must be vented to the outside. The engine should be installed at least two feet from any outside wall. Using an exhaust pipe which is too long or too small can cause excessive back pressure which will cause the engine to heat excessively and possibly burn the valves.

## MOUNTING

The generator must be mounted on a solid foundation (such as concrete) and set firmly on the foundation to isolate vibration of the generator when it is running. The generator must be mounted at least 6 inches above the floor or grade level as referenced in the National Fire Protection Association handbook (NFPA 110, Chapter 7, Section 7.4).

**DO NOT** remove the metal skids on the bottom of the generator. They are to resist damage to the bottom of the generator and to maintain alignment.

# GENERAL INFORMATION

## GENERATOR

This generator (Figure 4) is designed as a high-quality, portable (requires a trailer for transport) power source for telecom sites, lighting facilities, power tools, submersible pumps and other industrial and construction machinery.

## OPERATING PANEL

The “Operating Panel” is provided with the following:

- ECU-754 Controller with Gauge Unit Assembly
  - Oil Pressure Gauge
  - Water Temperature Gauge
  - Charging Voltmeter
  - Fuel Gauge
  - Tachometer
- Panel Light/Panel Light Switch
- Pre Heat Lamp
- Warning Lamp (Diagnostic)
- Hour Meter
- Engine Speed Switch
- Auto Start/Stop Switch
- Fuel Leak Detected Alarm Lamp

## CONTROL PANEL

The “Control Panel” is provided with the following:

- Frequency Meter (Hz)
- AC Ammeter (Amps)
- AC Voltmeter (Volts)
- Ammeter Change-Over Switch
- Voltage Regulator
- 3-Pole, 90-Amp Main Circuit Breaker
- “Control Box” (located behind Control Panel)
  - Automatic Voltage Regulator
  - Current Transformer
  - Starter Relay

## OUTPUT TERMINAL PANEL

The “Output Terminal Panel” is provided with the following:

- Two 120/240V output receptacles (CS-6369), 50A
- Two auxiliary circuit breakers, 50A
- Two 120V output receptacles (GFCI), 20A
- Two GFCI circuit breakers, 20A
- Four output terminal lugs (1Ø power)
- Battery Charger (Option)
- Engine Block Heater (Option)
- Low Coolant Switch (Option)
- Cam-Lok Connectors (Option)

## OPEN-DELTA EXCITATION SYSTEM

Each generator is equipped with a state-of-the-art, **open-delta** excitation system. The open-delta system consists of an electrically independent winding wound among stationary windings of the AC output section.

There are four connections of the open delta—A, B, C, and D. During steady state loads, the power from the voltage regulator is supplied from the parallel connections of A to B, A to D, and C to D. These three phases of the voltage input to the voltage regulator are then rectified and are the excitation current for the exciter section.

When a heavy load such as a motor starting or a short circuit occurs, the automatic voltage regulator (AVR) switches the configuration of the open delta to the series connection of B to C. This has the effect of adding the voltages of each phase to provide higher excitation to the exciter section and thus better voltage response during the application of heavy loads.

The connections of the AVR to the AC output windings are for sensing only. No power is required from these windings. The open-delta design provides virtually unlimited excitation current, offering maximum motor-starting capabilities. The excitation does not have a ‘fixed ceiling’ and responds according to the demands of the required load.

## ENGINE

This generator is powered by a 4-cylinder, 4-cycle, water-cooled, direct injection, turbocharged, EGR, DOC, Isuzu 4LE2T diesel engine. This engine is designed to meet every performance requirement for the generator. Reference Table 2 for engine specifications.

In keeping with MQ Power’s policy of constantly improving its products, the specifications quoted herein are subject to change without prior notice.

## MICROPROCESSOR CONTROL SYSTEM

A microprocessor controls the RPM of the engine. When the engine demand increases or decreases, the microprocessor system regulates the frequency variation to  $\pm 0.25\%$ .

## EXTENSION CABLES

When electric power is to be provided to various tools or loads at some distance from the generator, extension cords are normally used. Cables should be sized to allow for distance in length and amperage so that the voltage drop between the generator and point of use (load) is held to a minimum. Use the cable selection chart (Table 11) as a guide for selecting the proper extension cable size.

# MAJOR COMPONENTS

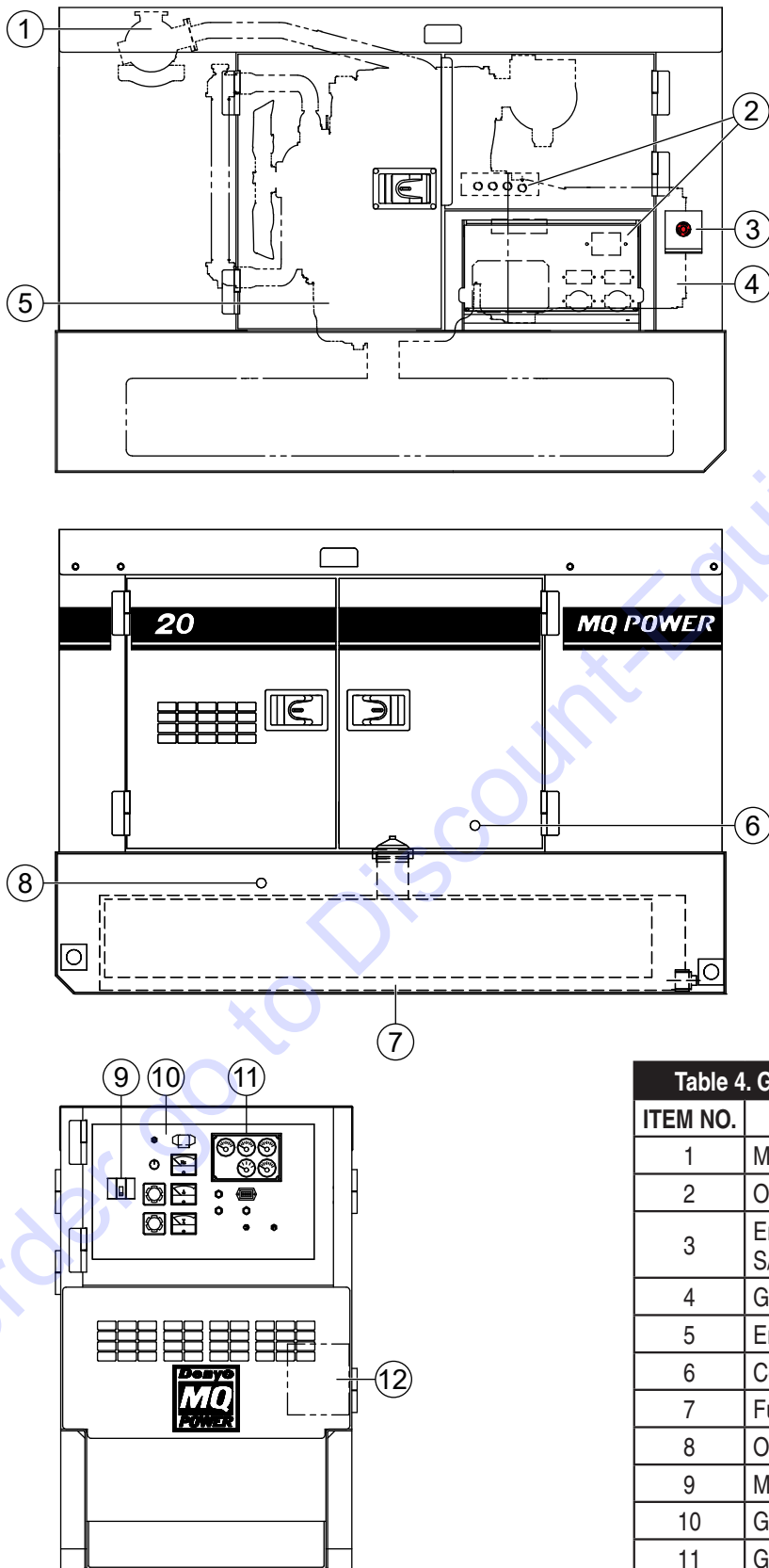
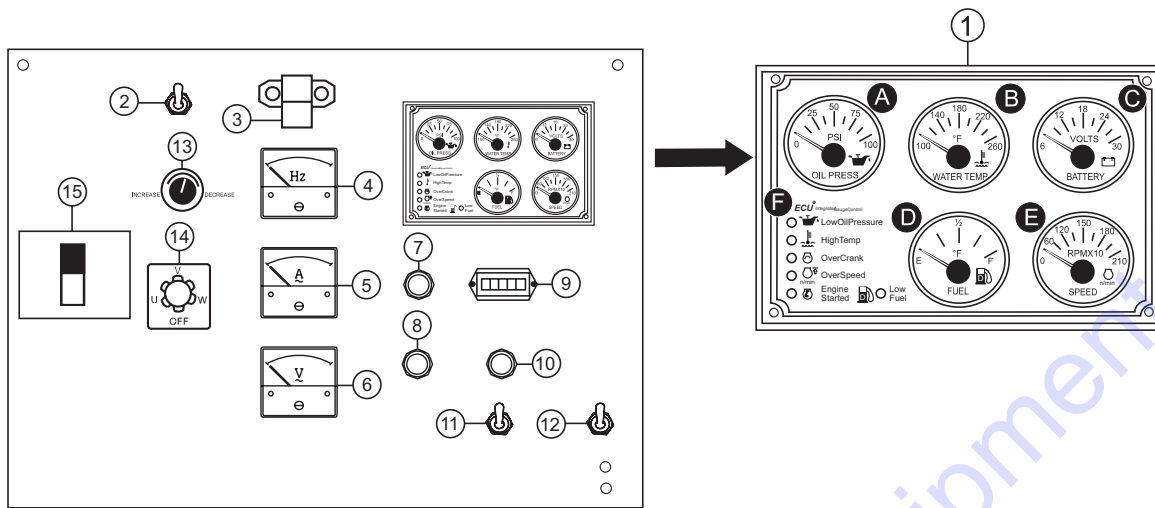

Figure 4. Major Components

Table 4. Generator Major Components	
ITEM NO.	DESCRIPTION
1	Muffler Assembly
2	Output Terminal Panel Assembly
3	Emergency Stop Switch Assembly S/N 8720596 and Above
4	Generator Assembly
5	Engine Assembly
6	Coolant Drain Assembly
7	Fuel Tank Assembly
8	Oil Drain Assembly
9	Main Circuit Breaker Assembly
10	Generator Control Panel Assembly
11	Gauge Unit Assembly
12	Battery Assembly

# ENGINE/GENERATOR CONTROL PANEL



**Figure 5. Engine/Generator Control Panel**

The definitions below describe the controls and functions of the Engine/Generator Control Panel (Figure 5).

1. **ECU Controller with Gauge Unit Assembly** — This assembly houses the various engine monitoring gauges. These gauges indicate: oil pressure, water temperature, charging voltmeter, fuel level, and engine speed RPM (tachometer).

- A. **Oil Pressure Gauge** — During normal operation this gauge should read approximately 50 psi (345 kPa). When starting the generator the oil pressure may read a little higher, but after the engine warms up the oil pressure should return to the correct pressure range.
- B. **Water Temperature Gauge** — During normal operation this gauge should read approximately 180°F (82°C).
- C. **Charging Voltmeter Gauge** — During normal operation this gauge indicate greater than 14 VDC.
- D. **Fuel Gauge** — Indicates the amount of diesel fuel available.
- E. **Tachometer** — Indicates engine speed in RPM for 60 Hz operation. This meter should indicate 1,800 RPM when the rated load is applied.

## F. Warning LEDs

- **Low Oil Pressure LED** — This LED will light when the engine oil pressure drops to 14.2 psi (98 kPa). This condition will cause the engine to shut down.
  - **High Temperature LED** — This LED will light when the coolant temperature has reached 212°F (100°C). This condition will cause the engine to shut down.
  - **Over Crank LED** — This LED will light when the engine has attempted to start 3 times and failed. The interval between the 3 start cycles is approximately 10 seconds.
  - **Over Speed LED** — This LED will light when the engine is running at an unsafe speed. This condition will cause the engine to shut down.
  - **Low Fuel LED** — This LED will light when the fuel level falls below 20%. Shutdown will activate at 5%.
  - **Engine Started LED** — This LED will light when the engine has started and is operating correctly.
2. **Panel Light Switch** — When activated will turn on the control panel light.
3. **Panel Light** — For operation at night, the panel light illuminates the control panel for ease of reading meters and gauges. Make sure the panel light switch is in the **OFF** position when the light is not in use.

## ENGINE/GENERATOR CONTROL PANEL

---

4. **Frequency Meter** — Indicates the output frequency in hertz (Hz). Normally 60 Hz.
5. **AC Ammeter** — Indicates the amount of current the load is drawing from the generator per leg selected by the ammeter phase-selector switch.
6. **AC Voltmeter** — Indicates the output voltage present at the **U,O, and V Output Terminal Lugs**.
7. **Fuel Leak Detected Alarm Lamp** — This lamp when ON indicates that fluids in the containment area have reached a high level.
8. **Warning Lamp** — This lamp turns ON when an engine fault/failure has occurred. Reference troubleshooting diagnostic section in this manual.
9. **Hour Meter** — Indicates the operational hours of the generator.
10. **Pre-Heat Lamp** — When the Auto Start/Stop Switch is placed in the manual position, this lamp will illuminate to indicate preheating of the engine glow plugs. When the lamp turns off, this indicates that the preheat cycle is complete and the engine can be started.
11. **Auto Start/Stop Switch** — This switch selects either manual or automatic operation. Center position is OFF (reset).
12. **Engine Speed Switch** — This switch controls the speed of the engine, low or high.
13. **Voltage Regulator Control Knob** — Allows  $\pm 5\%$  manual adjustment of the generator's output voltage.
14. **Ammeter Change-Over Switch** — This switch allows the AC ammeter to indicate the current flowing to the load connected to any phase of the output terminals, or to be switched off. This switch does not affect the generator output in any fashion, it is for current reading only.
15. **Main Circuit Breaker** — This three-pole, 90-amp main circuit breaker is provided to protect the **U,O, and V** output terminal lugs from overload.

# OUTPUT TERMINAL PANEL FAMILIARIZATION

## OUTPUT TERMINAL PANEL

The Output Terminal Panel (Figure 6) shown below is located on the right-hand side (left from control panel) of the generator. Lift up on the cover to gain access to receptacles and terminal lugs.

### NOTICE

**Terminal O** is neutral bonded to the ground from the factory.

## OUTPUT TERMINAL FAMILIARIZATION

The “Output Terminal Panel” (Figure 6) is provided with the following:

- Two 120/240 output receptacles @ 50 amps
- Two Aux. Circuit Breakers @ 50 amps
- Two 120V GFCI receptacles @ 20 amp
- Two GFCI Circuit Breakers @ 20 amps
- Four Output Terminal Lugs (U, O, V, and Ground)

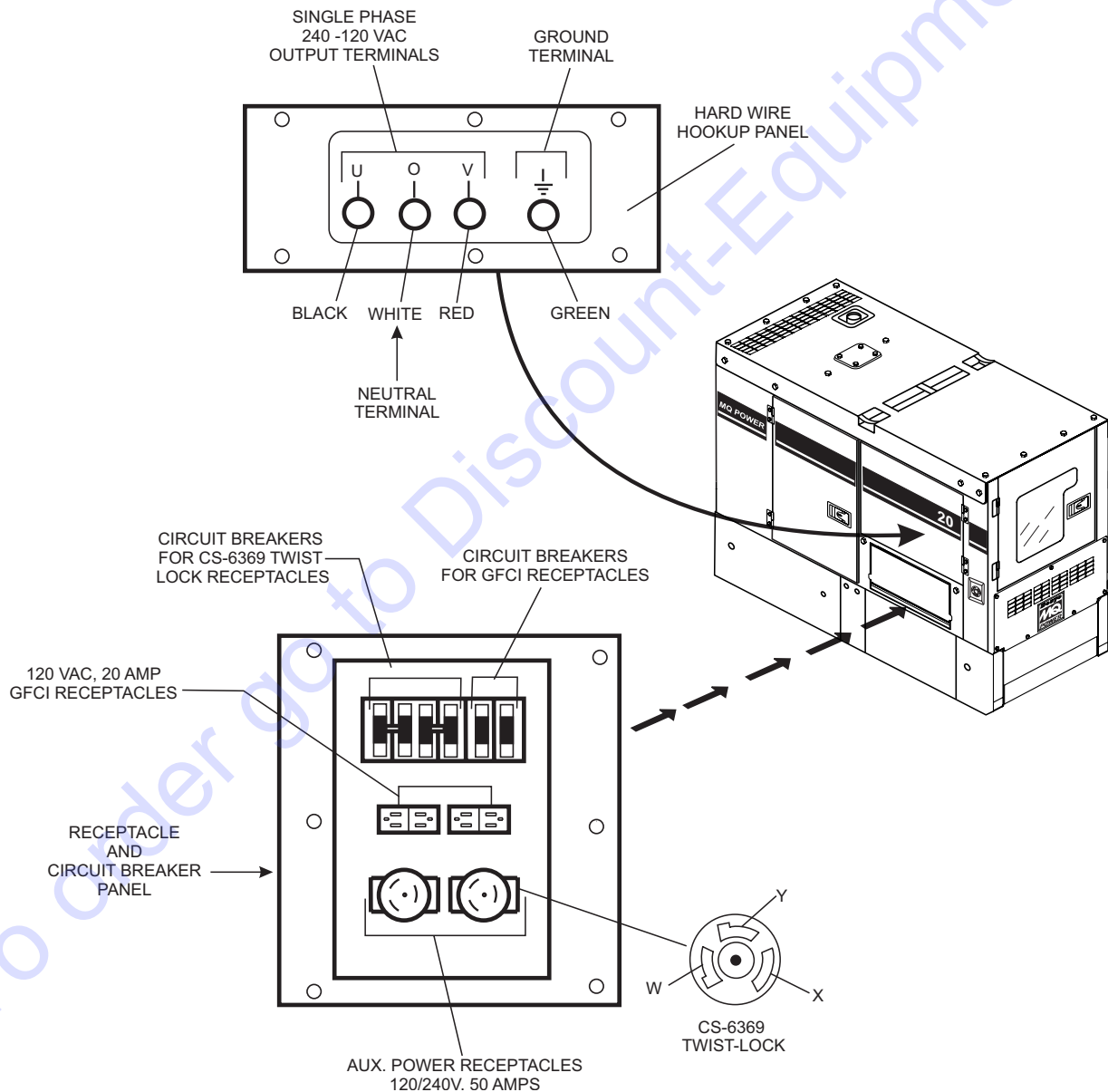

Figure 6. Output Terminal Panel

# OUTPUT TERMINAL PANEL FAMILIARIZATION

## 120 VAC GFCI Receptacles

### NOTICE

It is recommended that the GFCI receptacles be tested when the generator is initially uncrated. The receptacles should then be tested daily at startup.

There are two 120 VAC, 20-amp GFCI (duplex NEMA 5-20R) receptacles provided on the output terminal panel. Each receptacle is protected by a 20-amp circuit breaker. These breakers are located directly above the GFCI receptacles. Remember the load output (current) of both GFCI receptacles is dependent on the load requirements of the U, O, and V output terminal lugs.

Pressing the **reset** button resets the GFCI receptacle after being tripped. Pressing the **test button** (See Figure 7) in the center of the receptacle will check the GFCI function. Both receptacles should be tested at least once a month. Reference the maintenance section in this manual for further testing of the GFCI receptacle.

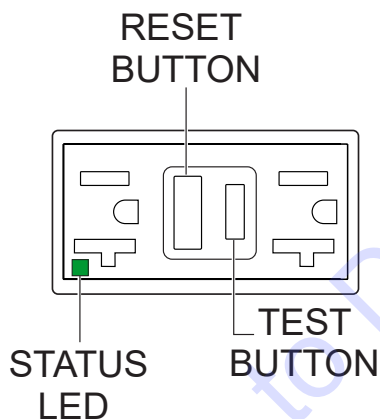

Figure 7. GFCI Receptacle

## Twist-Lock Dual-Voltage 120/240 VAC Receptacles

There are two 120/240V, 50-amp auxiliary twist-lock (CS-6369) receptacles (Figure 8) provided on the output terminal panel. These receptacles can **only** be accessed when the main and auxiliary circuit breakers are in the ON position.

CS6369 TWIST-LOCK RECEPTACLES

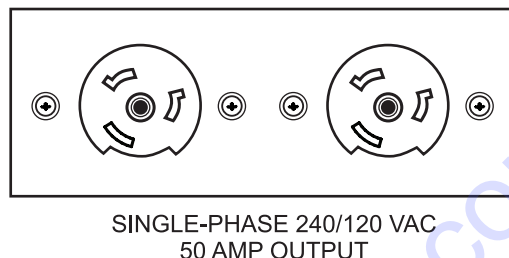

Figure 8. 120/240V Twist-Lock Auxiliary Receptacles

Each auxiliary receptacle is protected by a 50-amp circuit breaker. These breakers are located directly above the GFCI receptacles. Remember the load output (current) on all three receptacles is dependent on the load requirements of the **output terminal lugs**.

## Removing the Plastic Face Plate (Hard Wire Hookup Panel)

The **Output Terminal Lugs** are protected by a plastic face plate cover (Figure 9). Unscrew the securing bolts and lift the plastic terminal cover to gain access to the terminal enclosure.

After the load wires have been securely attached to the terminal lugs, reinstall the plastic face plate.

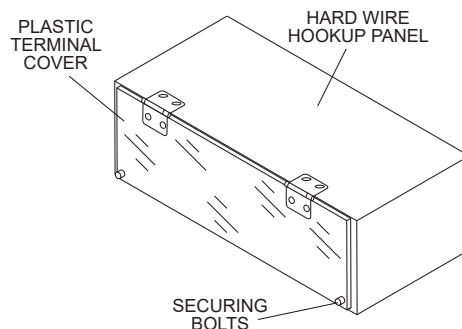

Figure 9. Plastic Face Plate (Output Terminal Lugs)

# OUTPUT TERMINAL PANEL FAMILIARIZATION

## Connecting Loads

Loads can be connected to the generator (Figure 10) by the output terminal lugs, convenience receptacles, or optional cam-locks. Make sure to read the operation manual before attempting to connect a load to the generator.

To protect the output terminals from overload, a 3-pole, 90-amp **main** circuit breaker is provided. Make sure to switch **ALL** circuit breakers to the **OFF** position prior to starting the engine.

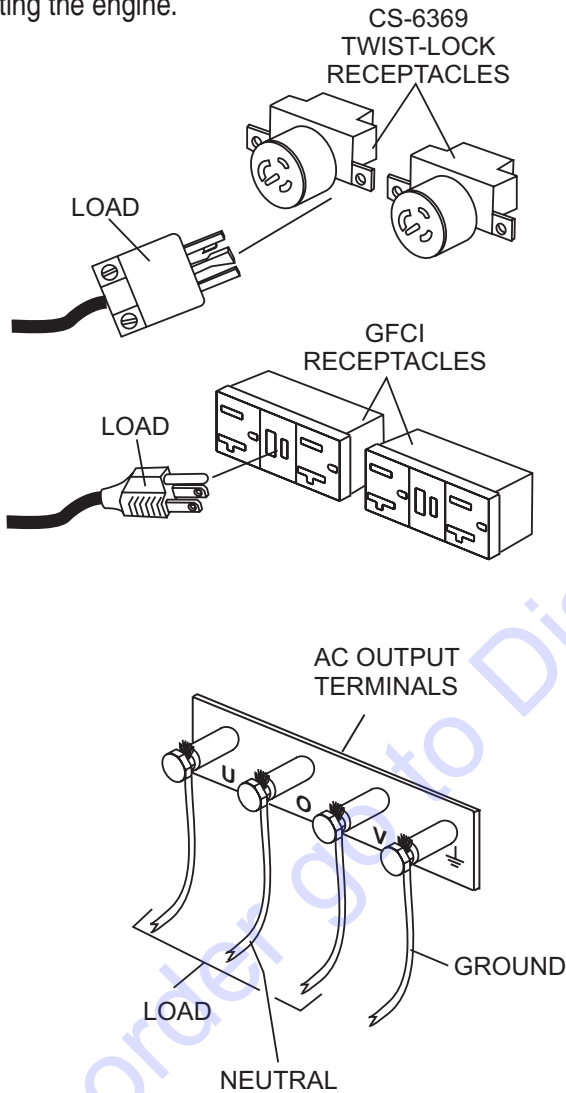

Figure 10. Connecting Loads

## SINGLE-PHASE LOAD

Always be sure to check the nameplate on the generator and equipment to ensure the wattage, amperage, frequency, and voltage requirements are satisfactorily supplied by the generator for operating the equipment.

Generally, the wattage listed on the nameplate of the equipment is its rated output. Equipment may require 130–150% more wattage than the rating on the nameplate, as the wattage is influenced by the efficiency, power factor, and starting system of the equipment.

### NOTICE

If wattage is not given on the equipment's nameplate, approximate wattage may be determined by multiplying the nameplate voltage by the nameplate amperage.

$$\text{WATTS} = \text{VOLTAGE} \times \text{AMPERAGE}$$

The power factor of this generator is 1.0. See Table 5 below when connecting loads.

**Table 5. Power Factor By Load**

Type of Load	Power Factor
Single-phase induction motors	0.4–0.75
Electric heaters, incandescent lamps	1.0
Fluorescent lamps, mercury lamps	0.4–0.9
Electronic devices, communication equipment	1.0
Common power tools	0.8

**Table 11. Cable Selection (60 Hz, Single-Phase Operation)**

Current in Amperes	Load in Watts		Maximum Allowable Cable Length			
	At 100 Volts	At 200 Volts	#10 Wire	#12 Wire	#14 Wire	#16 Wire
2.5	300	600	1,000 ft.	600 ft.	375 ft.	250 ft.
5	600	1,200	500 ft.	300 ft.	200 ft.	125 ft.
7.5	900	1,800	350 ft.	200 ft.	125 ft.	100 ft.
10	1,200	2,400	250 ft.	150 ft.	100 ft.	
15	1,800	3,600	150 ft.	100 ft.	65 ft.	
20	2,400	4,800	125 ft.	75 ft.	50 ft.	

CAUTION: Equipment damage can result from low voltage.

### NOTICE

Cable selection table is a general guideline. **ALWAYS** consult local and national electrical codes when sizing cables.

### NOTICE

Motors and motor-driven equipment draw much greater current for starting than during operation.

An inadequately sized connecting cable which cannot carry the required load can cause a voltage drop which can burn out the appliance or tool and overheat the cable. See Table 6.

- When connecting a resistance load such as an incandescent lamp or electric heater, a capacity of up to the generating set's rated output (kW) can be used.
- When connecting a fluorescent or mercury lamp, a capacity of up to the generating set's rated output (kW) multiplied by 0.6 can be used.
- When connecting an electric drill or other power tools, pay close attention to the required starting current capacity.

When connecting ordinary power tools, a capacity of up to the generating set's rated output (kW) multiplied by 0.8 can be used.

### DANGER

Before connecting this generator to any building's electrical system, a **licensed electrician** must install an **isolation (transfer) switch**. Serious damage to the building's electrical system may occur without this transfer switch.

# AC AMMETER GAUGE READING

## HOW TO READ THE AC AMMETER GAUGE

The AC ammeter gauge is controlled by the AC ammeter change-over switch.

This switch is located on the control panel and **does not** affect the generator output. It is provided to help observe how much current is being supplied at the UOV terminal lugs.

### AC Ammeter Gauge Reading

Place the **AC Ammeter Change-Over Switch** (Figure 11) in the U position and observe the current reading (load drain) on the U terminal as indicated on the **AC Ammeter Gauge**. This process can be repeated for terminal V.

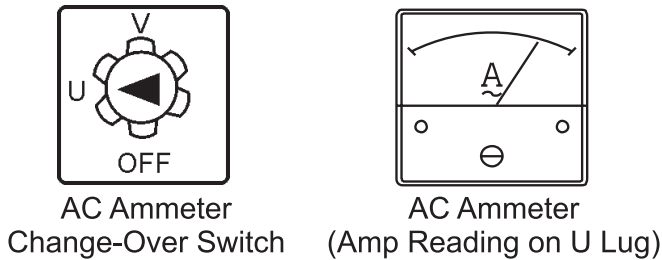

Figure 11. Current Reading (Load Drain)

#### NOTICE

The **ammeter** gauge will only show a reading when the **Output Terminal Lugs** are connected to a load and in use.

# OUTPUT TERMINAL PANEL CONNECTIONS

## UOV TERMINAL OUTPUT VOLTAGES

240/120V output voltages can be obtained using the **output terminal lugs**.

The voltage regulator (Figure 13) allows the user to increase or decrease the selected voltage.

### 1Ø-240V Output Terminal Voltage

1. Connect the load wires to the output terminal lugs as shown in Figure 12.

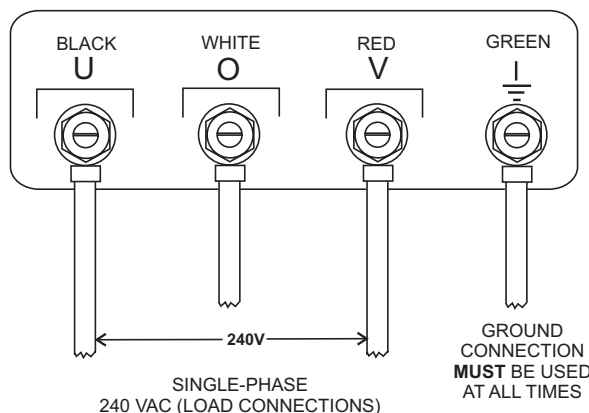

**Figure 12. Output Terminal Lugs  
1Ø-240V Connections**

2. Turn the voltage regulator control knob (Figure 13) clockwise to increase voltage output, turn counterclockwise to decrease voltage output. Use the voltage regulator control knob whenever fine tuning of the output voltage is required.



**Figure 13. Voltage Regulator Control Knob**

### 1Ø-120V Output Terminal Voltage

1. Connect the load wires to the output terminal lugs as shown in Figure 14.

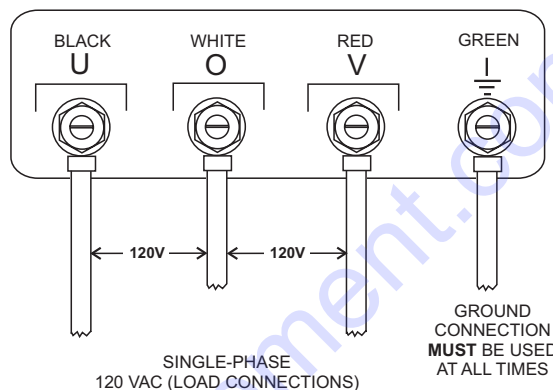

**Figure 14. Output Terminal Lugs  
1Ø-120V Connections**

#### NOTICE

**ALWAYS** make sure that the connections to the UOV terminals are **secure** and **tight**. The possibility of arcing exists that could cause a fire.

2. Turn the voltage regulator control knob (Figure 13) clockwise to increase voltage output, turn counterclockwise to decrease voltage output.

# INSPECTION/SETUP

## ENGINE OIL CHECK

1. To check the engine oil level, place the generator on secure, level ground with the engine stopped.
2. Remove the dipstick from its holder (Figure 15) and wipe it clean.

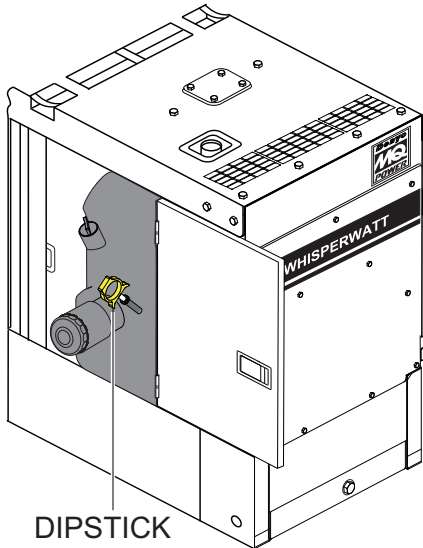

Figure 15. Engine Oil Dipstick

3. Reinsert the dipstick, then remove the dipstick from its holder. Check the oil level shown on the dipstick (Figure 16).

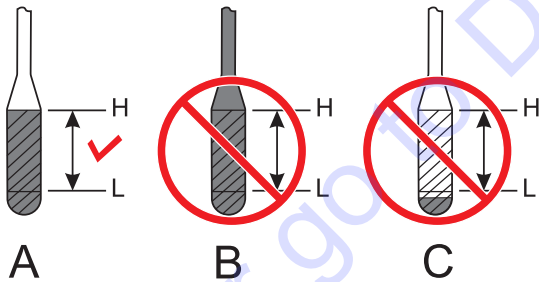

Figure 16. Engine Oil Dipstick

4. Verify that the engine oil level is maintained between the H and L markings on the dipstick as referenced in Figure 16A.

5. If the engine oil level is low (Figure 16C), remove the oil filler cap (Figure 17) and fill to a safe operating level (max) as indicated by the dipstick (Figure 16A). Fill with recommended type oil as listed in Table 6. Maximum oil capacity is 11.2 quarts (10.5 liters).

### NOTICE

When adding engine oil **DO NOT** overfill (Figure 16B).

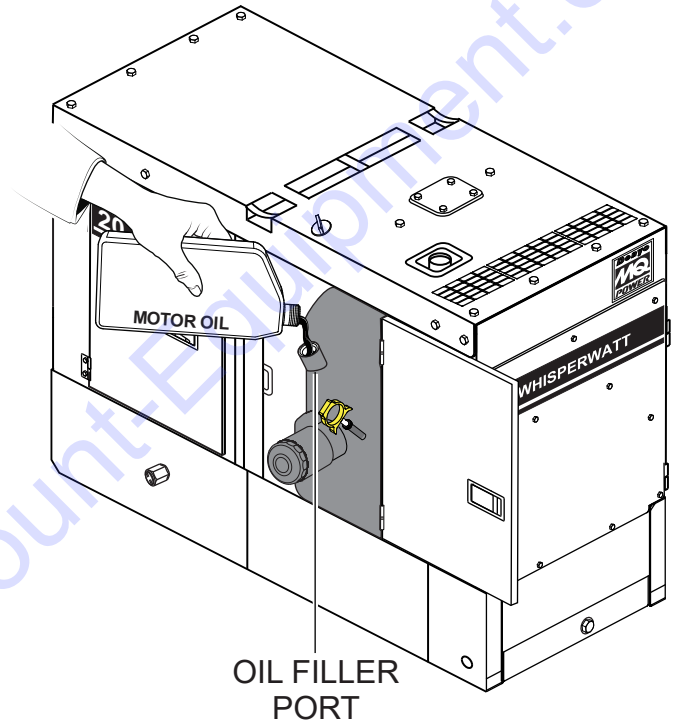
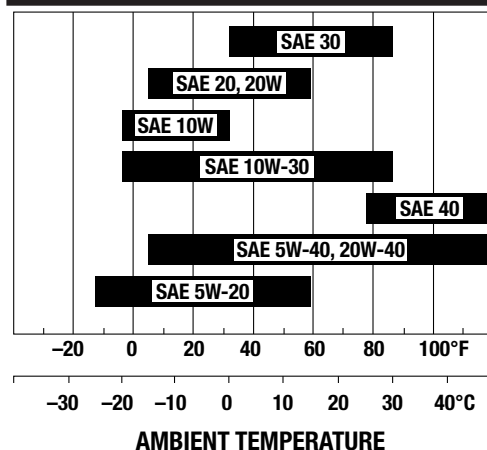

Figure 17. Engine Oil Filler Port

When checking the engine oil, be sure to check if the oil is clean. If the oil is not clean, drain the oil as referenced in the maintenance section of this manual.

Table 6. Recommended Motor Oil



## FUEL CHECK

**! DANGER**



Fuel spillage on a **hot** engine can cause a **fire** or **explosion**. If fuel spillage occurs, wipe up the spilled fuel completely to prevent fire hazards. **NEVER** smoke around or near the generator.

## Refilling The Fuel System

**NOTICE**

**DO NOT** refuel while the engine is running.

**! CAUTION**

**ONLY** properly trained personnel who have read and understand this section should refill the fuel tank system.

This generator has an internal fuel tank (Figure 18) located inside the enclosure and may also be equipped with a trailer-mounted fuel tank. **ALWAYS** fill the fuel tank with clean fresh #2 diesel fuel. **DO NOT** fill the fuel tank beyond its capacity.

Pay attention to the fuel tank capacity when replenishing fuel. The fuel tank cap must be closed tightly after filling. Handle fuel in a safety container. If the container does not have a spout, use a funnel. Wipe up any spilled fuel immediately.

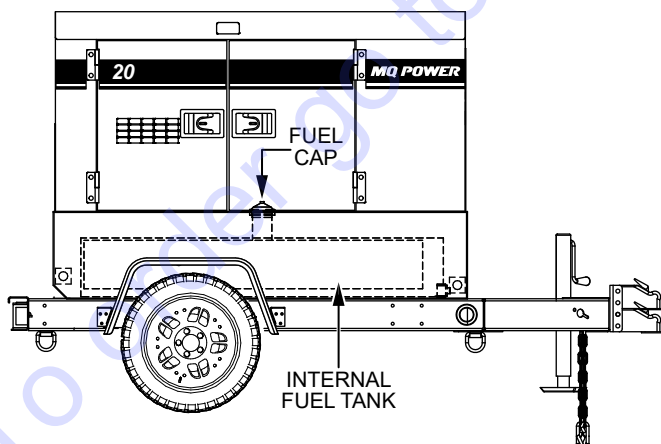



Figure 18. Fuel Tank

## Refueling Procedure

**! WARNING**



**Diesel fuel** and its vapors are dangerous to your health and the surrounding environment. Avoid skin contact and/or inhaling fumes.

1. **Level Tanks** — Make sure fuel cells are level with the ground. Failure to do so will cause fuel to spill from the tank before reaching full capacity (Figure 19).

**! CAUTION**

**ALWAYS** place the trailer on firm, level ground before refueling to prevent spilling and to maximize the amount of fuel that can be pumped into the tank.

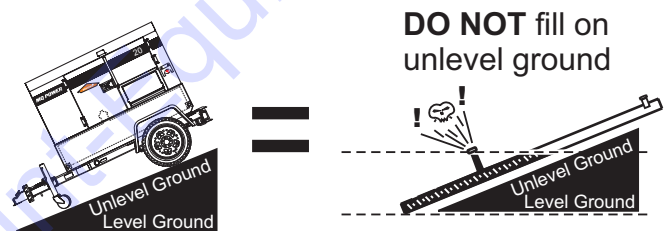

Figure 19. Only Fill On Level Ground

**NOTICE**

**ONLY** use #2 diesel fuel when refueling.

2. Open cabinet doors on the “right side” of the generator (from the generator control panel position). Remove the fuel cap and fill the tank (Figure 20).

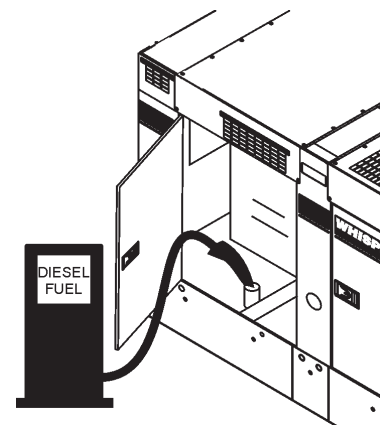

Figure 20. Fueling The Generator

## INSPECTION/SETUP

- NEVER overfill fuel tank** — It is important to read the fuel gauge when filling the trailer fuel tank. **DO NOT** wait for fuel to rise in the filler neck (Figure 21).

FUEL GAUGE LOCATED ON CONTROL PANEL

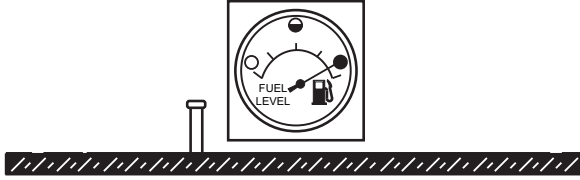

Figure 21. Full Fuel Tank

### CAUTION

**DO NOT OVERFILL** the fuel system. Leave room for fuel expansion. Fuel expands when heated (Figure 22).

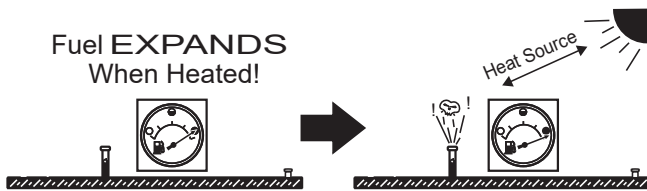

Figure 22. Fuel Expansion

## COOLANT (ANTIFREEZE/SUMMER COOLANT/WATER)

Isuzu recommends antifreeze/summer coolant for use in their engines, which can be purchased in concentrate (and mixed with 50% demineralized water) or pre-diluted. See the **Isuzu Engine Owner's Manual** for further details.

### WARNING



When adding coolant/antifreeze mix to the radiator, **DO NOT** remove the radiator cap until the unit has completely cooled. The possibility of **hot!** coolant exists which can cause severe burns.

Day-to-day addition of coolant is done from the reserve tank. When adding coolant to the radiator, **DO NOT** remove the radiator cap until the unit has completely cooled. See Table 7 for engine, radiator, and reserve tank coolant capacities.

### NOTICE

Normally, only the coolant level in the reserve tank needs to be checked. However, the radiator cap should be opened once a week to verify that coolant is visible (full) inside the radiator.

- Verify that the coolant level in the coolant reserve tank is between the **FULL** and **LOW** markings as shown in Figure 23.

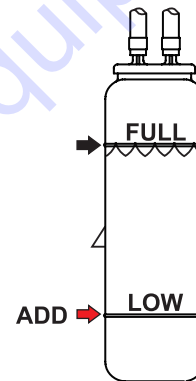

Figure 23. Coolant Reserve Tank

Table 7. Coolant Capacity

Engine and Radiator	2.3 gal (8.8 liters)
Reserve Tank	0.24 gal (0.9 liters)

## Operation in Freezing Weather

When operating in freezing weather, be certain the proper amount of antifreeze (Table 8) has been added.

Table 8. Anti-Freeze Operating Temperatures

Vol % Anti-Freeze	Freezing Point	
	°C	°F
50	-37	-34

### NOTICE

When the antifreeze is mixed with water, the antifreeze mixing ratio **must be** less than 50%.

## Cleaning The Radiator

The engine may overheat if the **radiator cooling fins** (Figure 24) become overloaded with dust or debris. Periodically clean the radiator fins with compressed air. Cleaning inside the machine is dangerous, so clean only with the engine turned **OFF** and the **negative** battery terminal disconnected.

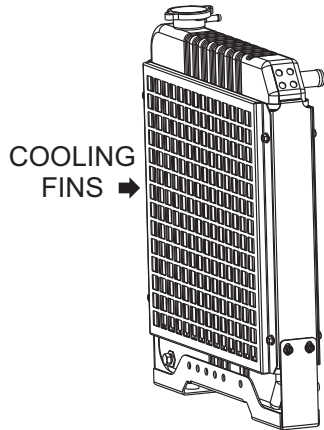

Figure 24. Radiator (Cooling Fins)

## ENGINE AIR CLEANER

Periodic cleaning/replacement of the **engine air cleaner** is necessary. Inspect the air cleaner (Figure 25) in accordance with the **Maintenance** section of this manual or the **Isuzu engine owner's manual**.

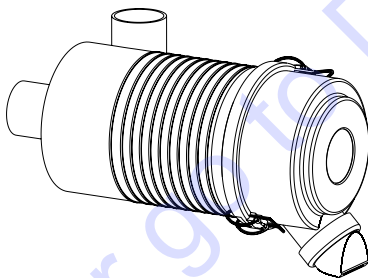

Figure 25. Engine Air Cleaner

## FAN BELT TENSION

A slack fan belt may contribute to overheating, or to insufficient charging of the battery. Inspect the fan belt for damage and wear and adjust it in accordance with the **Isuzu Engine Owner's Manual**.

The fan belt tension is proper if the fan belt bends 0.22–0.24 in. (5.5–6.0 mm) when pressed with the thumb as shown in Figure 26.

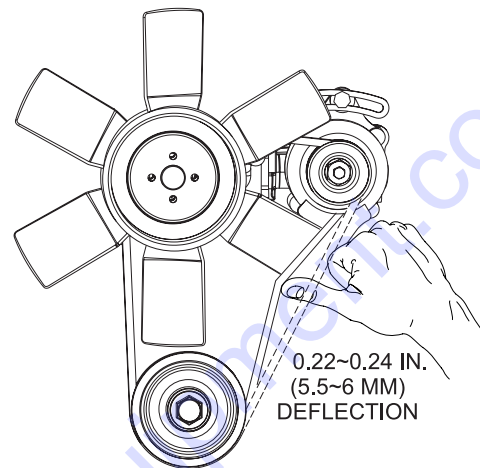

Figure 26. Fan Belt Tension

### CAUTION



**NEVER** place hands near the belts or fan while the generator set is running.

## BATTERY

This unit is of negative ground. **DO NOT** connect in reverse. Always maintain the battery fluid level between the specified marks. Battery life will be shortened if the fluid levels are not properly maintained. Add only distilled water when replenishment is necessary.

**DO NOT** overfill. Check to see whether the battery cables are loose. Poor contact may result in poor starting or malfunctions. **ALWAYS** keep the terminals firmly tightened. Coat the terminals with an approved battery terminal treatment compound. Replace the battery with only the recommended type battery. The battery type used in this generator is BCI Group 27.

The battery is sufficiently charged if the specific gravity of the battery fluid is 1.28 (at 68°F). If the specific gravity should fall to 1.245 or lower, it indicates that the battery is dead and needs to be recharged or replaced.

Before charging the battery with an external electric source, be sure to disconnect the battery cables.

## Battery Cable Installation

**ALWAYS** be sure the battery cables (Figure 27) are properly connected to the battery terminals as shown below. The **red cable** is connected to the positive terminal of the battery, and the **black cable** is connected to the negative terminal of the battery.

### **CAUTION**

**ALWAYS** disconnect the negative terminal **FIRST** and reconnect the negative terminal **LAST**.

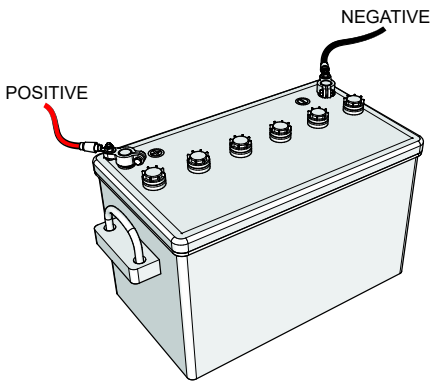

**Figure 27. Battery Connections**

When connecting the battery do the following:

1. **NEVER** connect the battery cables to the battery terminals while the **Auto Start/Stop switch** is in either the **AUTO** or **MANUAL** position. **ALWAYS** make sure that this switch is in the **OFF/RESET** position when connecting the battery.
2. Place a small amount of battery terminal treatment compound around both battery terminals. This will ensure a good connection and will help prevent corrosion around the battery terminals.

### **NOTICE**

If the battery cables are connected incorrectly, electrical damage to the generator will occur. Pay close attention to the polarity of the battery when connecting.

### **CAUTION**

Inadequate battery connections may cause poor starting of the generator or other malfunctions.

## ALTERNATOR

The polarity of the alternator is negative grounding type. When an inverted circuit connection takes place the circuit will be in short circuit instantaneously resulting in alternator failure.

**DO NOT** put water directly on the alternator. Entry of water into the alternator can cause corrosion and damage the alternator.

## WIRING

Inspect the entire generator for bad or worn electrical wiring or connections. If any wiring or connections are exposed (insulation missing), replace wiring immediately.

## PIPING AND HOSE CONNECTIONS

Inspect all piping, oil hose, and fuel hose connections for wear and tightness. Tighten all hose clamps and check hoses for leaks.

If any hose (fuel or oil) lines are defective replace them immediately.

# GENERATOR START-UP PROCEDURE (MANUAL)

## BEFORE STARTING

### CAUTION

The engine's exhaust contains harmful emissions. **ALWAYS** have adequate ventilation when operating. Direct exhaust away from nearby personnel.

### WARNING

**NEVER** manually start the engine with the **main, GFCI, or auxiliary** circuit breakers in the **ON** (closed) position.

- Place the **main, GFCI, and aux.** circuit breakers (Figure 28) in the **OFF** position prior to starting the engine.

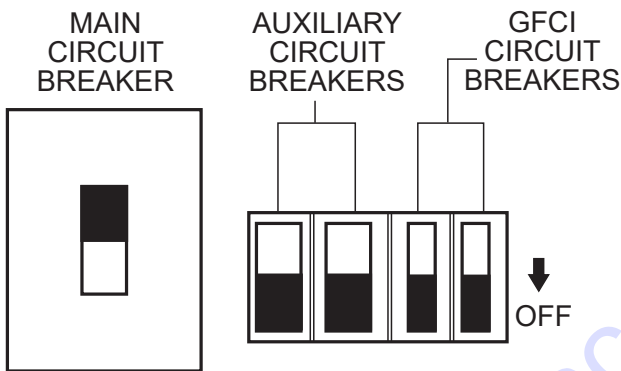

**Figure 28. Main, Aux. and GFCI Circuit Breakers (OFF)**

- Connect the load to the **receptacles** or the **output terminal lugs** as shown in Figure 10. Tighten terminal nuts securely to prevent load wires from slipping out.
- Close all engine enclosure doors (Figure 29).

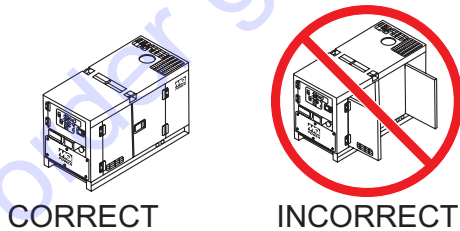

**Figure 29. Engine Enclosure Doors**

## STARTING (MANUAL)

- Make sure the **Diagnostic switch** (located inside the control box) is placed in the **OFF** position. See Figure 30. Make sure the control panel is closed properly before proceeding.

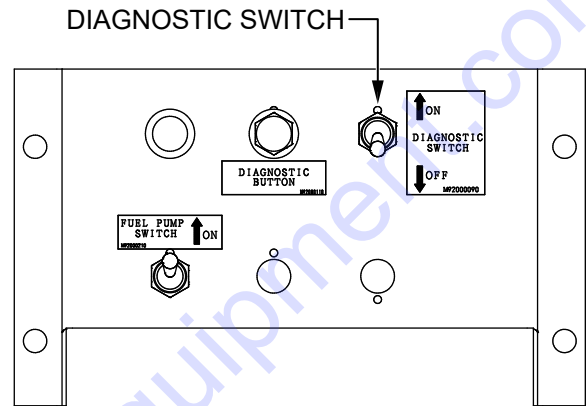

**Figure 30. Diagnostic Switch (OFF Position)**

- Place the engine speed switch (Figure 31) in the **LOW** (down) position.



**Figure 31. Engine Speed Switch (Low)**

- Place the **Auto Start/Stop Switch** in the **MANUAL** position to start the engine (Figure 32).

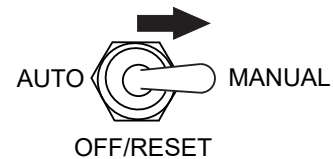

**Figure 32. Auto Start/Stop Switch (Manual Position)**

- Depending on the temperature of the coolant (cold weather conditions), the pre-heat lamp (Figure 33) will light (**ON**) and remain on until the pre-heating cycle has been completed. Upon completion of the pre-heating cycle, the light will turn **OFF** and the engine will start up automatically.

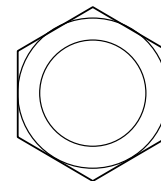

**Figure 33. Pre-Heat Lamp**

# GENERATOR START-UP PROCEDURE (MANUAL)

- Once the engine starts, let the engine run for 1–2 minutes (longer in cold weather conditions). Listen for any abnormal noises. If any abnormalities exist, shut down the engine and correct the problem.

## NOTICE

In cold weather conditions warm up the engine 5–7 minutes before placing the unit into operation.

- Verify that the engine started status LED on the ECU controller is on.

## NOTICE

If the engine fails to start after 3 attempts, the over crank LED on the ECU controller will turn on and the Auto Start/Stop Switch must be placed in the Off/Reset position before the engine can be restarted.

- If the engine is running smoothly, place the engine speed switch (Figure 34) in the **HIGH** (up) position.



**Figure 34. Engine Speed Switch (High)**

- The generator's frequency meter (Figure 35) should display the 60-cycle output frequency in **HERTZ**.

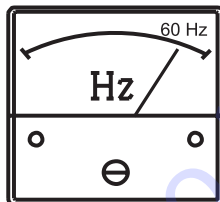

**Figure 35. Frequency Meter**

- The generator's AC voltmeter (Figure 36) will display the generator's output in **VOLTS**.

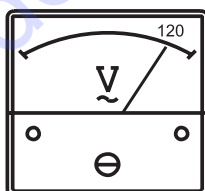

**Figure 36. Voltmeter**

- If the voltage is not within the specified tolerance, use the voltage regulator control knob (Figure 37) to increase or decrease the desired voltage.



**Figure 37. Voltage Regulator Control Knob**

- The ammeter (Figure 38) will indicate **zero amps** with no load applied. When a load is applied, the ammeter will indicate the amount of current that the load is drawing from the generator.



**Figure 38. Ammeter (No Load)**

- The engine oil pressure gauge (Figure 39) will indicate the oil pressure of the engine. Under normal operating conditions the oil pressure is approximately 50 psi (345 kPa).

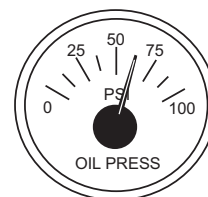

**Figure 39. Oil Pressure Gauge**

- The **coolant temperature gauge** (Figure 40) will indicate the coolant temperature. Under normal operating conditions the coolant temperature should be approximately 180°F (82°C).

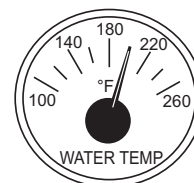

**Figure 40. Coolant Temperature Gauge**

# GENERATOR START-UP PROCEDURE (MANUAL)

14. The **tachometer gauge** (Figure 41) will indicate the speed of the engine when the generator is operating. Under normal operating conditions this speed is approximately 1,800 rpm.

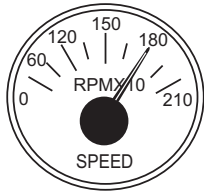

**Figure 41. Engine Tachometer Gauge**

15. Place the **main, GFCI, and aux.** circuit breakers in the **ON** position (Figure 42).

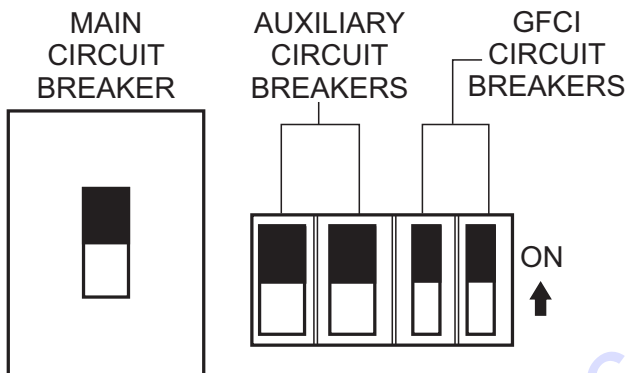

**Figure 42. Main, Aux. and GFCI Circuit Breakers (ON)**

16. Observe the generator's ammeter (Figure 43) and verify it reads the anticipated amount of current with respect to the load. The ammeter will only display a current reading if a load is in use.

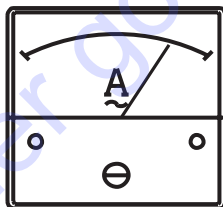

**Figure 43. Ammeter (Load)**

17. The generator will run until manually stopped or an abnormal condition occurs.

# GENERATOR START-UP PROCEDURE (AUTO MODE)

## STARTING (AUTO MODE)

### DANGER



Before connecting this generator to any building's electrical system, a **licensed electrician** must install an **isolation (transfer) switch**. Serious damage to the building's electrical system may occur without this transfer switch.

### NOTICE

When connecting the generator to an isolation (transfer) switch, **ALWAYS** have power applied to the generator's internal battery charger. This will ensure that the engine will not fail due to a dead battery.

### NOTICE

When the generator is set to **AUTO** mode, the generator will **automatically start** in the event of commercial power falling below a prescribed level by means of a contact closure that is generated automatically by a transfer switch.

### WARNING

When running the generator in **AUTO** mode, remember the generator can start up at any time without warning. **NEVER** attempt to perform any maintenance when the generator is in auto mode.

### NOTICE

When the **Auto Start/Stop switch** is placed in the **AUTO** position, the engine glow plugs will be warmed and the engine will start automatically.

### NOTICE

The engine speed switch **must** be set to the "High" position when running in the **auto-start** mode. Failing to set the switch in the proper position can result in damage to your generator when it turns on.

When starting the generator in **AUTO** mode use the "Manual Start-up" procedure except where noted (see below).

1. Perform steps 1 through 5 in the Before Starting section as outlined in the Manual Starting Procedure.
2. Place the **Auto Start/Stop Switch** (Figure 44) in the **AUTO** position.

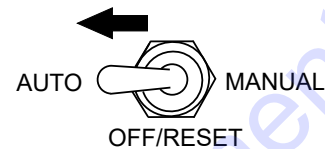

**Figure 44. Auto Off/Reset Manual Switch (AUTO)**

3. Continue operating the generator as outlined in the Manual Start-up procedure (start at step 7).

# GENERATOR SHUTDOWN PROCEDURES

## **WARNING**

**NEVER** stop the engine suddenly except in an emergency.

## NORMAL SHUTDOWN PROCEDURE

To shut down the generator, use the following procedure:

1. Place the **MAIN, GFCI, and LOAD** circuit breakers to the **OFF** position as shown in Figure 45.

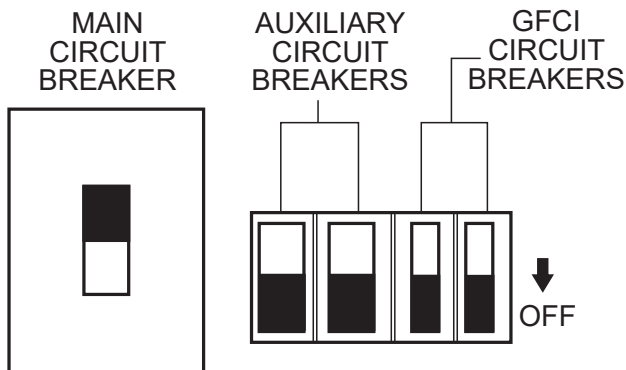

**Figure 45. Main, Aux. and GFCI Circuit Breakers (OFF)**

2. Let the engine cool by running it at low speed for 3–5 minutes with no load applied.
3. Place the **Auto Start/Stop Switch** (Figure 46) in the **OFF/RESET** position.



**Figure 46. Auto Start/Stop Switch (Off/Reset)**

4. Verify that all status LEDs on the ECU control panel are **OFF** (not lit).
5. Remove all loads from the generator.
6. Inspect the entire generator for any damage or loosening of components that may have occurred during operation.

## EMERGENCY SHUTDOWN PROCEDURE

### NOTICE

The Emergency Stop Pushbutton Switch should only be used to stop the engine in case of an emergency or to lock out operation during service. The emergency stop switch should **NEVER** be used for routine stopping of the engine.

1. To stop the engine in the event of an emergency, push the **Emergency Stop Pushbutton Switch** (Figure 47).

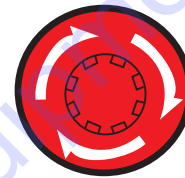

**Figure 47. Emergency Stop Button**

2. The emergency stop switch is a push-locked type switch. The switch contact can only be released by rotating the button in the clockwise direction. The engine can not be restarted until the contact is released (**closed**).
3. Place the **MAIN, GFCI, and LOAD** circuit breakers as shown in Figure 45 to the **OFF** position.

## AUTOMATIC SHUTDOWN SYSTEM

This unit is equipped with safety devices to automatically stop the engine in the event of low oil pressure approximately 14 psi (97 kPa), high water temperature approximately 212°F (100°C), or overspeed approximately +15%. The alarm lamps on the ECU illuminate to signify the reason for the shutdown.

### NOTICE

Before inspecting the generator, check that the Auto Start/Stop switch is in the **OFF/RESET** position, and place all circuit breakers in the **OFF** position. Allow sufficient time for adequate cooling. When ready to restart, complete all steps in the Generator Startup Procedure section of this manual.

# MAINTENANCE

Table 9. Inspection/Maintenance		10 Hrs. DAILY	250 Hrs.	500 Hrs. or Every 12 Months	1,000 Hrs.	OTHER
<b>Engine</b>	Check Engine Oil and Coolant Levels	X				
	Check Fuel Filter/Water Separator Bowl	X				
	Check Air Cleaner	X				
	Check Air Cleaner Element	X				
	Check for Leaks/Hoses/Clamps	X				
	Check for Loosening of Parts	X				
	Drain Water in Fuel	X				
	Change Engine Oil and Oil Filter * 1		X			
	Clean Unit, Inside and Outside		X			
	Replace Fuel Filter Elements			X		
	Check Engine Mounts			X		
	Service Battery			X		
	Check Air Intake Hoses			X		
	Check Fan Belt Condition (Replace if Necessary)	X				
	Check Automatic Belt Tensioner	X				
	Check Electrical Ground Connection			X		
	Clean Radiator, Check Cooling System			X		
	Coolant Solution Analysis, Add SCAs as Required			X		
	Pressure Test Cooling System			X		
	Check Engine Speed			X		
	Test Thermostats					3,000 hrs. or 3 yrs.
	Test Glow Plugs					3,000 hrs. or 3 yrs.
	Flush and Refill Cooling System					2,000 hrs. or 2 yrs.
	Clean Inside of Fuel Tank				X	
	Replace Air Cleaner Elements * 3					As Required
	Check Battery Acid Level	X				
Drain Environmental Tank			X			
Check All Hoses and Clamps				X		
<b>Generator</b>	Measure Insulation Resistance Over 3M Ohms		X			
	Check Rotor Rear Support Bearing			X		

\*1 During initial operation of a new engine, change oil and filter between a minimum of 100 hours and a maximum of 250 hours. Service interval depends on type of oil.

\*2 Add "Supplemental Coolant Additives" (SCAs) to recharge the engine coolant.

\*3 Replace the primary air filter element when the restriction indicator shows a vacuum of 625 mm (25 in. H<sub>2</sub>O).

\*4 If the blowby hose needs to be replaced, ensure that the slope of the blowby hose is at least 1/2 inch per foot, with no sags or dips that could collect moisture and/or oil.

\*5 Accumulation of carbon (soot, unburned fuel) in the exhaust pipe line and muffler could cause not only system derates but also could lead to fire incident. To destroy the soot and unburned fuel, run the unit at rated power for some period of time until the exhaust gas become mostly colorless every 250 hours of operation time. The carbon will be easier to be generated when the unit operates at less than 40% of rated power. In this case, perform the above procedures at a shorter interval time.

\*6 Applying a large load at one time to the unit when carbon deposits have accumulated in the exhaust system could produce fire/sparks which could lead to abnormal combustion. Therefore it is recommended to **apply the load gradually** and observe the exhaust gas color (colorless) during the process.

\*7 Fire or sparks may emit from the exhaust gas outlet during the **carbon emission accumulation check** (load). Make sure the area surrounding the unit is free from any **flammable** material.

## GENERAL INSPECTION

Prior to each use, the generator should be cleaned and inspected for deficiencies. Check for loose, missing or damaged nuts, bolts, or other fasteners. Also check for fuel, oil, and coolant leaks. Use Table 9 as a general inspection and maintenance guideline. For more detailed engine maintenance instructions, refer to the engine owner's manual.

## ENGINE AIR CLEANER

This Isuzu diesel engine is equipped with a replaceable, high-density, paper air cleaner element (Figure 48). The air cleaner is also equipped with an inner (secondary) element that is used as a backup filter should the primary element become damaged. Check the air cleaner daily or before starting the engine. Replace the air cleaner as needed.

### NOTICE

If the engine is operating in very dusty or dry grass conditions, a clogged air cleaner will result. This can lead to a loss of power, excessive carbon buildup in the combustion chamber, and high fuel consumption. Change the air cleaner more frequently if these conditions exist.

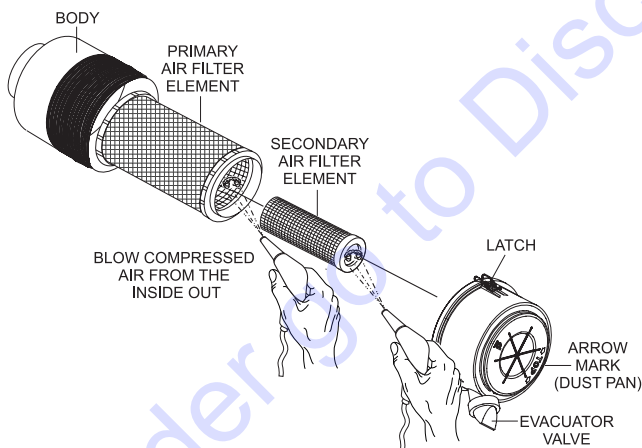

Figure 48. Engine Air Cleaner

## Primary And Secondary Air Cleaner Elements

**Every 250 hours:** Remove the air cleaner elements and clean them with a light spray of compressed air.

### CAUTION



Wear protective equipment such as approved safety glasses or face shields and dust masks or respirators when cleaning air filters with compressed air.

1. Release the latches that secure the cover to the air cleaner body (Figure 48).
2. Remove the **air cleaner cover** (Figure 48) and set it aside.
3. Remove both the primary and secondary air cleaner elements (Figure 48).
4. Check for and correct heavy buildup of dirt and debris along with loose or damaged components.

### NOTICE

Operating the engine with loose or damaged air cleaner components could allow unfiltered air into the engine causing premature wear and failure.

5. To clean the **primary element** (paper air filter) as shown in Figure 48, tap the filter element several times on a hard surface to remove dirt, or blow compressed air, not to exceed 30 psi (207 kPa, 2.1 kgf/cm<sup>2</sup>), through the filter element from the inside out.
6. Clean the **secondary element** (paper air filter) as described in step 5.
7. Replace both elements if they are damaged or excessively dirty.
8. Clean the inside of the **air cleaner body** (Figure 48).
9. Reinstall the primary and secondary air filter elements back into the air cleaner body.
10. Reinstall the air cleaner cover and secure with latches.

### NOTICE

**DO NOT** run the engine with the air cleaner removed or without an element.

## Air Cleaner Restriction Indicator

The air cleaner is equipped with a **restriction indicator** (Figure 49). As the air cleaner element becomes clogged, air intake restriction increases and the indicator signal shows **RED**, indicating that the element needs to be replaced. After replacing the air cleaner element, press the restriction indicator button to reset the indicator.

PUSH BUTTON TO RESET

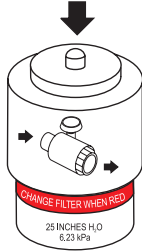

**Figure 49. Air Cleaner Restriction Indicator**

### NOTICE

The air cleaner element should not be changed until the indicator displays **RED**. Dispose of the old element. It cannot be cleaned or reused.

## ENGINE FUEL FILTER

Inspect the **engine fuel filter** daily. If the fuel filter has collected a significant amount of water and sediment at the bottom of the cup, it should be drained off immediately.

## Draining The Fuel Filter

1. Loosen the **air bleeder plug** (Figure 50) on the fuel filter body.

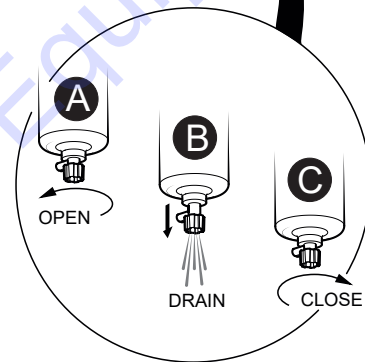
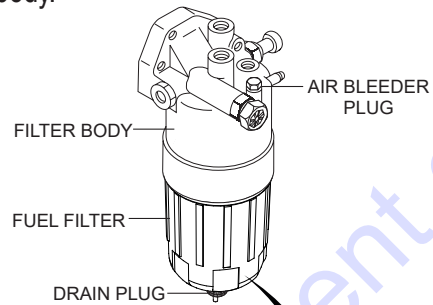
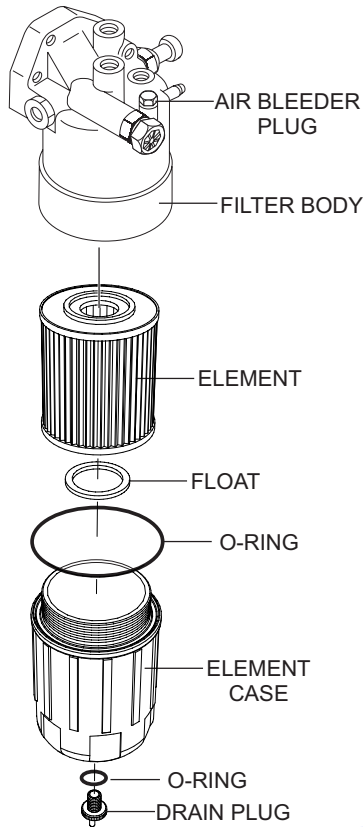

**Figure 50. Draining The Fuel Filter**

2. To discharge the fuel inside the fuel filter cartridge, open the **drain valve** on the fuel filter by turning the knob **counterclockwise** (Figure 50A) approximately 3-1/2 turns until the valve drops down 1 inch (25.4 mm) and draining occurs (Figure 50B).
3. Let the residue or foreign substances inside the fuel filter flow into a suitable container.
4. At completion of draining, close the drain valve (Figure 50C).

## Fuel Filter Element Replacement

- Using a **filter wrench**, remove the **element case** from the **fuel filter body** (Figure 51).



**Figure 51. Fuel Filter Replacement**

- Wipe the inside of the **filter body** (Figure 51) with a clean cloth to remove any foreign matter or debris that may have accumulated.
- Insert the new fuel filter element into the element case.
- Replace both **O-rings**. Coat each O-ring with a small amount of clean 15W-40 engine oil.
- Reinstall the element case first by hand until it makes contact with the fuel filter body surface.
- Torque the element case to 22.4 lbf-ft (30 N·m).
- Torque the drain plug to 1.4 lbf-ft (2.0 N·m).
- Remove the air from the fuel system. Refer to **Bleeding the Fuel System** in the Isuzu engine owner's manual.

## ELECTROMAGNETIC FUEL PUMP (500 HOURS)

The filter inside the **electromagnetic fuel pump** (Figure 52) is either a paper type or steel mesh type depending on the fuel pump type. Clean or replace the fuel pump filter as follows:

- Disconnect any electrical connections that are attached to the fuel pump.
- Prepare a fuel collector to drain the fuel into. Secure any fuel lines to prevent fuel from spilling.
- Remove the fuel pump from the generator enclosure.
- Remove the **filter** and **gaskets** (Figure 52) from the fuel pump housing.

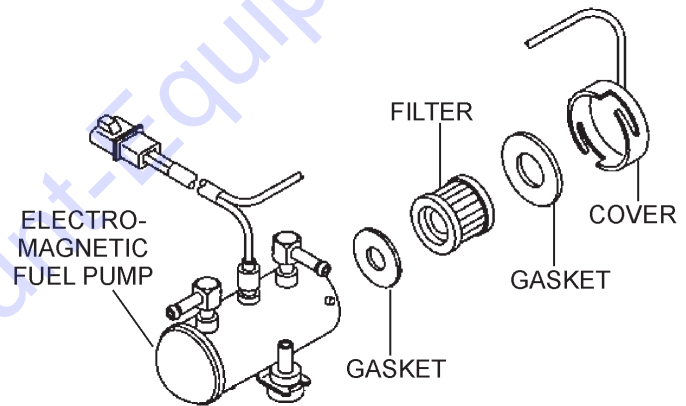

**Figure 52. Electromagnetic Fuel Pump**

### NOTICE

When the fuel pump filter is removed, always make sure to replace both gaskets and clean the magnet portion inside the cover.

- Clean or replace the fuel pump filter. Replace both gaskets.
- Reassemble the fuel pump and mount it back onto the generator enclosure.
- Reconnect all fuel lines and electrical components.
- Check for fuel leaks.

## DRAINING THE CONTAINMENT TANK

1. This generator is equipped with an **environmental containment tank**. Inspect this tank regularly.
2. If the tank becomes full with fluids, remove the **drain bolt** (Figure 53), then allow the fluids to drain into a suitable container.

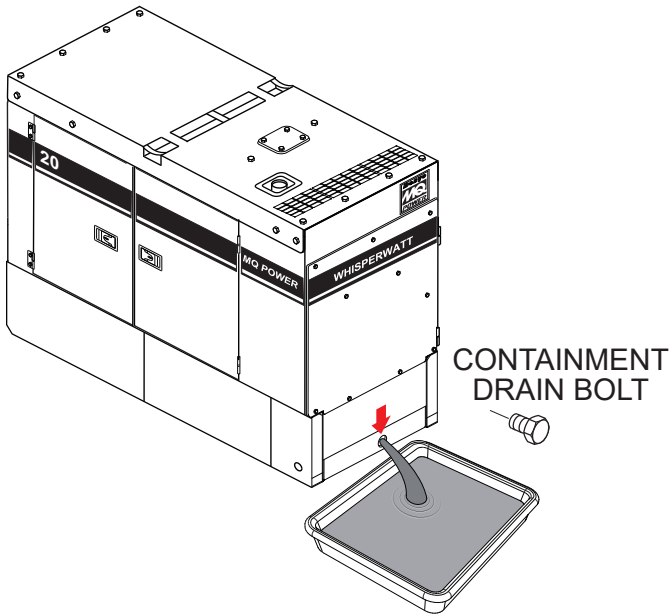

Figure 53. Draining The Containment Tank

## REMOVING WATER FROM THE FUEL TANK

After prolonged use, water and other impurities accumulate in the bottom of the fuel tank. Occasionally inspect the fuel tank for water contamination and drain the contents if required.

During cold weather, the more empty volume inside the tank, the easier it is for water to condense. This can be reduced by keeping the tank full with diesel fuel.

## CLEANING INSIDE THE FUEL TANK

If necessary, drain the fuel inside the fuel tank completely. Using a **spray washer** (Figure 54), wash out any deposits or debris that have accumulated inside the fuel tank.

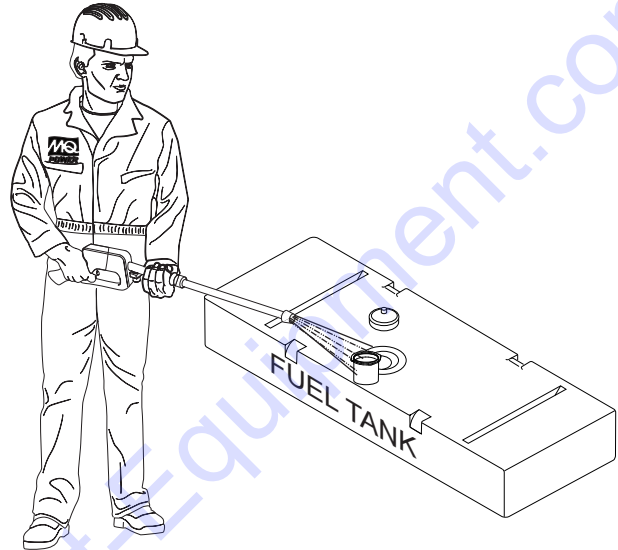

Figure 54. Cleaning The Fuel Tank

## FUEL TANK INSPECTION

In addition to cleaning the fuel tank, inspect the following components for wear:

- **Rubber Suspension** — Look for signs of wear or deformity due to contact with oil. Replace the rubber suspension if necessary.
- **Fuel Hoses** — Inspect nylon and rubber hoses for signs of wear, deterioration, or hardening.
- **Fuel Tank Lining** — Inspect the fuel tank lining for signs of excessive amounts of oil or other foreign matter.

## DRAINING THE ENGINE OIL

1. Run the engine until the engine coolant reaches a temperature of 140°F (60°C).
2. Turn the engine **OFF**.
3. Remove the oil dipstick from its holder.
4. Remove the **oil drain cap** (Figure 55).

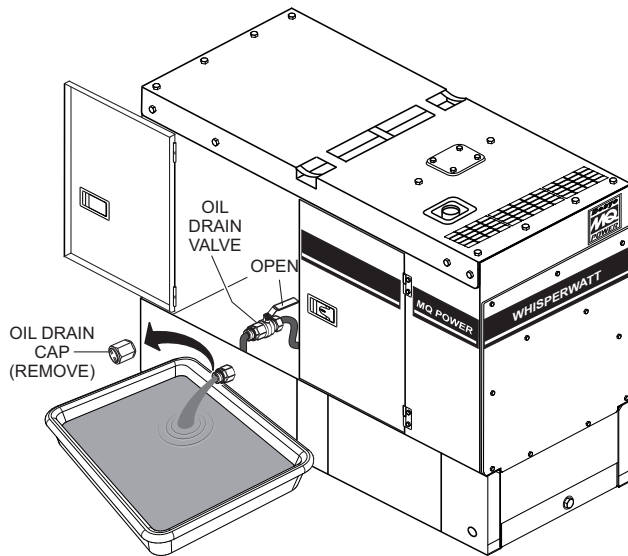
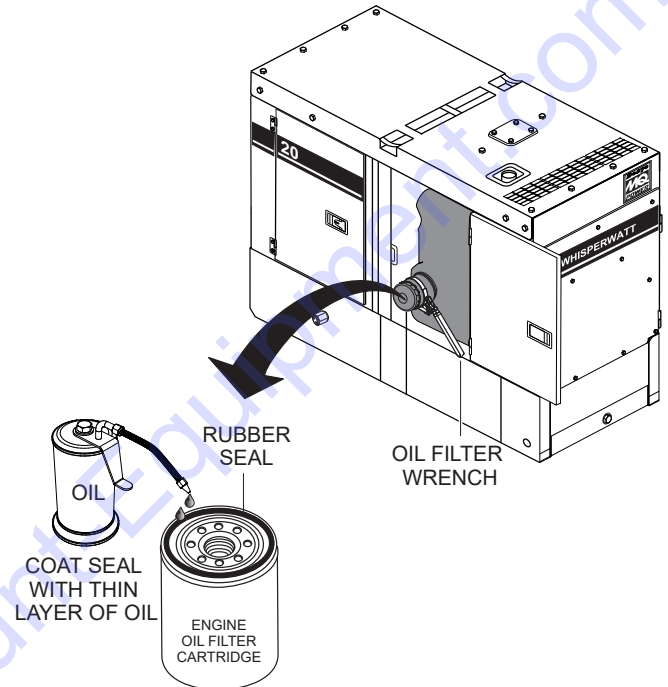

**Figure 55. Draining Engine Oil**

5. Place the **oil drain valve** in the open position (Figure 55) and allow the oil to drain into a suitable container.
6. After the engine oil has completely drained, reinstall the oil drain cap and tighten securely.
7. Place the oil drain valve in the closed position.

## ENGINE OIL FILTER REPLACEMENT

1. Clean the area around the oil filter head.
2. Using an **oil filter wrench** (Figure 56), remove the **engine oil filter**.



**Figure 56. Oil Filter Replacement**

3. Coat the rubber seal (gasket) surface of the new oil filter with clean 15W-40 engine oil (Figure 56).
4. Install the new oil filter (main) first by hand until it makes contact with the filter head surface. Tighten it another 3/4 turn using a filter wrench.
5. Fill the engine crankcase with high-quality detergent oil classified "For Service CI-4." Fill to the upper limit of the dipstick. **DO NOT** overfill. Refer to Table 2 for engine oil capacity.
6. Run the engine for several minutes. Watch for oil leakage. Shut the engine down and allow it to sit for several minutes. Top off the oil to the upper limit on the dipstick.

## DRAINING THE ENGINE COOLANT

### WARNING



**DO NOT** remove the pressure cap from the radiator when the engine is hot! Wait until the coolant temperature is below 120°F (50°C) before removing the pressure cap. Heated coolant spray or steam can cause severe scalding and personal injury.

1. Remove the **radiator pressure cap** (Figure 57) only when the coolant temperature is below 120°F (50°C).

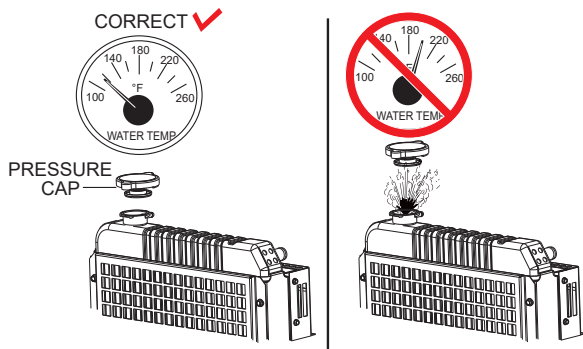

**Figure 57. Radiator Pressure Cap Removal**

2. Open the cabinet door and remove the **coolant drain bolt and O-ring** (Figure 58), then allow the coolant to drain into a suitable container.

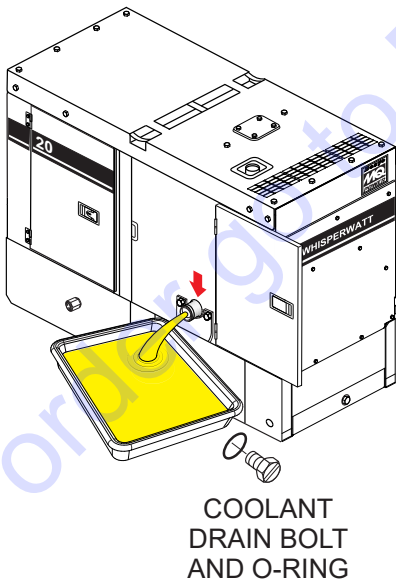

**Figure 58. Draining Engine Coolant**

3. After the coolant has completely drained, reinstall the coolant drain bolt and O-ring.
4. Reinstall the radiator pressure cap and tighten securely.

5. Flush out the radiator and replace the coolant. Refer to *Cleaning the Coolant Passages* and *Filling the Coolant System* in the Isuzu engine owner's manual.

## RADIATOR CLEANING

The radiator (Figure 59) should be spray-cleaned with a high-pressure washer when excessive amounts of dirt and debris have accumulated on the cooling fins or tube. When using a high-pressure washer, stand at least 5 feet (1.5 meters) away from the radiator to prevent damage to the fins and tube.

### NOTICE

It may be necessary to remove additional generator components in order to access the radiator for cleaning.



**Figure 59. Radiator Cleaning**

## DRIVE BELT

### Drive Belt Tension

A slack drive belt may contribute to overheating or insufficient charging of the battery. Adjust the drive belt in accordance with the Isuzu engine owner's manual.

### Drive Belt Inspection

Inspect the **drive belt** (Figure 60) for damage and wear. Horizontal cracks (across the belt) are acceptable. Vertical cracks (direction of belt ribs) that intersect with horizontal cracks are not acceptable.

Also, examine the belt and determine if it is **oil soaked** or **glazed** (a hard shiny appearance on the sides of the belt). Either of these two conditions can cause the belt to run hot, which can weaken it and increase the danger of it breaking.

If the drive belt exhibits any of the above wear conditions, replace the drive belt immediately.

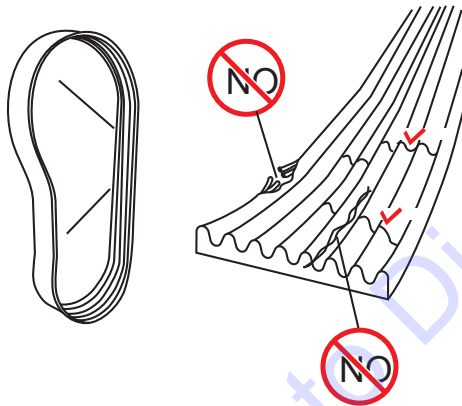

Figure 60. Drive Belt Inspection

## TESTING THE GFCI RECEPTACLE

### NOTICE

The GFCI receptacle is designed to interrupt power when a ground fault exists to prevent injuries and shock hazards. **DO NOT** use the GFCI receptacle if the test below fails. Consult a qualified electrician for repair or replacement of the GFCI receptacle. Test the GFCI receptacle **at least once a month**.

1. Start the generator as outlined in the start-up procedure in this manual.
2. Place a **GFCI circuit breaker** (Figure 61) in the **ON** position.

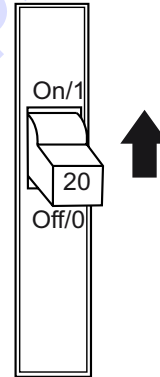

Figure 61. GFCI Circuit Breaker

3. Verify that the **status LED** on the corresponding **GFCI receptacle** (Figure 62) is **ON (GREEN)**.

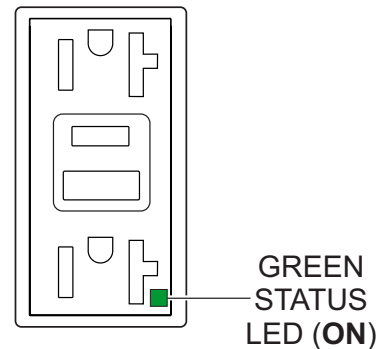
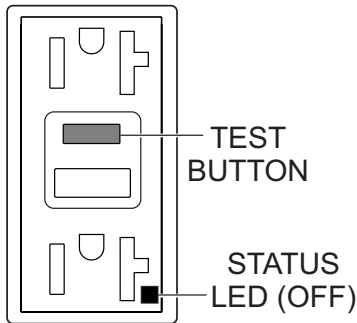

Figure 62. GFCI Receptacle (ON)

4. Press the **TEST button** (Figure 63) on the GFCI receptacle and verify that the status LED turns **OFF**.



**Figure 63. GFCI Receptacle (OFF)**

5. Press the **RESET button** (Figure 64) to restore power to the GFCI receptacle and verify that the status LED is **ON (GREEN)**.

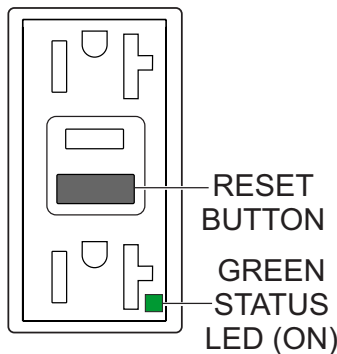

**Figure 64. GFCI Receptacle (ON/Restore)**

6. If the status LED (Figure 65) is **flashing (RED)**, **DO NOT** use the GFCI receptacle. Replace it immediately.

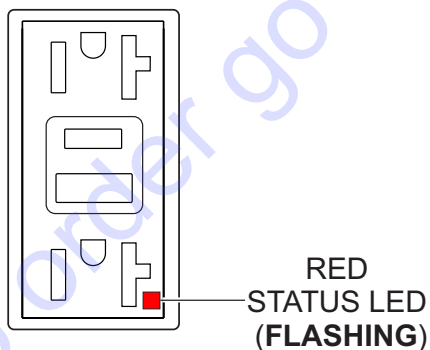

**Figure 65. GFCI Receptacle (Red Flashing LED)**

7. Repeat the above procedure for all other GFCI receptacles.

## GENERATOR STORAGE

For long-term storage of the generator the following is recommended:

- Drain the fuel tank completely. Treat with a fuel stabilizer if necessary.
- Completely drain the oil from the crankcase and refill if necessary with fresh oil.
- Clean the entire generator, internal and external.
- Disconnect the battery.
- Make sure engine coolant is at the proper level.
- Cover the generator and store it in a clean, dry place.
- If the generator is mounted on a trailer, jack the trailer up and place it on blocks so the tires do not touch the ground, or block and completely remove the tires.

## OPTIONAL ENGINE BLOCK HEATER AND INTERNAL BATTERY CHARGER 120 VAC INPUT RECEPTACLES

This generator can be equipped with an **engine block heater** and an **internal battery charger** as **options**. They are provided with electrical cords to connect to a commercial power source.

The engine block heater and internal battery charger both require 120 VAC in order to operate. A receptacle (Figure 66) has been provided on the output terminal panel to allow commercial power to be applied.

These receptacles will **ONLY** function when commercial power has been supplied to them (Figure 66). When using extension cords, refer to Table 6 for the correct size and length.

When using the generator in hot climates there is no reason to apply power to the engine block heater. However, if the generator will be used in cold climates it is always a good idea to apply power to the heater at all times.

If the generator will be used daily, the battery should normally not require charging. If the generator will be idle (not used) for long periods of time, apply power to the battery charger receptacle via commercial power using a power cord of adequate size.

### NOTICE

If the generator will be idle (not used) for long periods of time, **ALWAYS** keep power supplied to the generator's internal battery charger to ensure adequate starting capability.

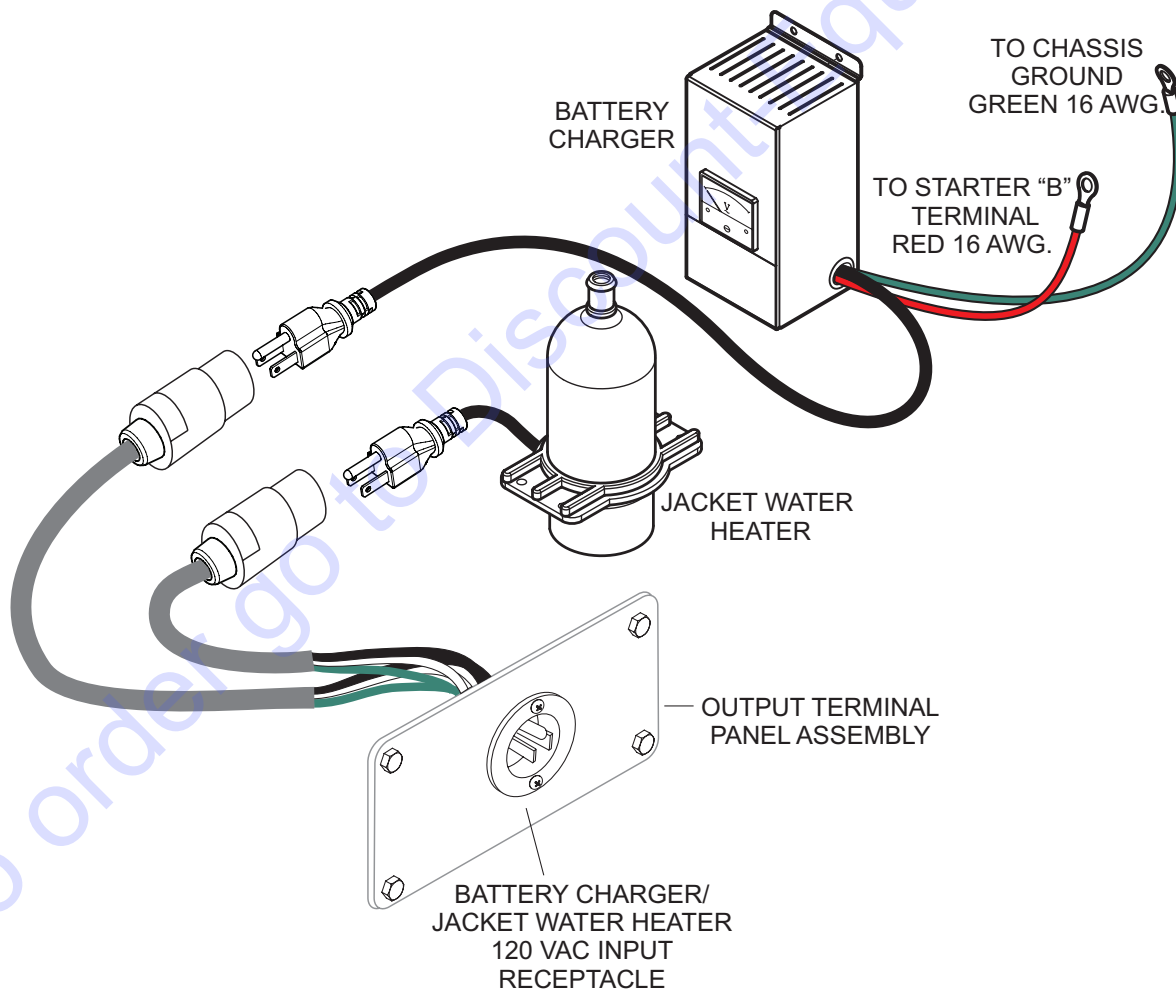

Figure 66. Engine Block Heater And Battery Charger (Options)

## EMISSION CONTROL

The emission control system employed with the Isuzu 4LE2T diesel engine consists of a Diesel Oxidation Catalyst (DOC).

This device oxidizes large amounts of harmful nitrogen oxides (NO<sub>x</sub>) and particulate matter (PM) which are emitted by diesel engines. These exhaust emissions pose serious environmental and health risks. No maintenance or service is required for the DOC device used on this generator.

### Diesel Oxidation Catalyst (DOC)

The DOC (Figure 67) does not filter particles, it oxidizes them. This catalyst (honeycomb-like structure) uses a chemical process to break down pollutants in the exhaust stream into less harmful components. In general this catalyst collects/burns accumulated particulates. The DOC contains palladium and platinum which serve as catalysts to oxidize hydrocarbons and carbon monoxide.

## PREVENTIVE MAINTENANCE PROGRAMS

Most challenging to a rental organization is the fact that a customer's power assumptions may not meet the minimum load requirements of the power equipment selected. When in doubt, it is always recommended to apply a **load bank application** to the equipment following a longer rental period.

Equipment on extended, long-term contracts needs periodic on-site inspection. If possible, interview the operator and survey the equipment hooked up to the generator to estimate load conditions.

Preventive maintenance and a few extra steps prevent downtime and protect your investment and business. A well-planned preventive maintenance program will reward you with years of service.

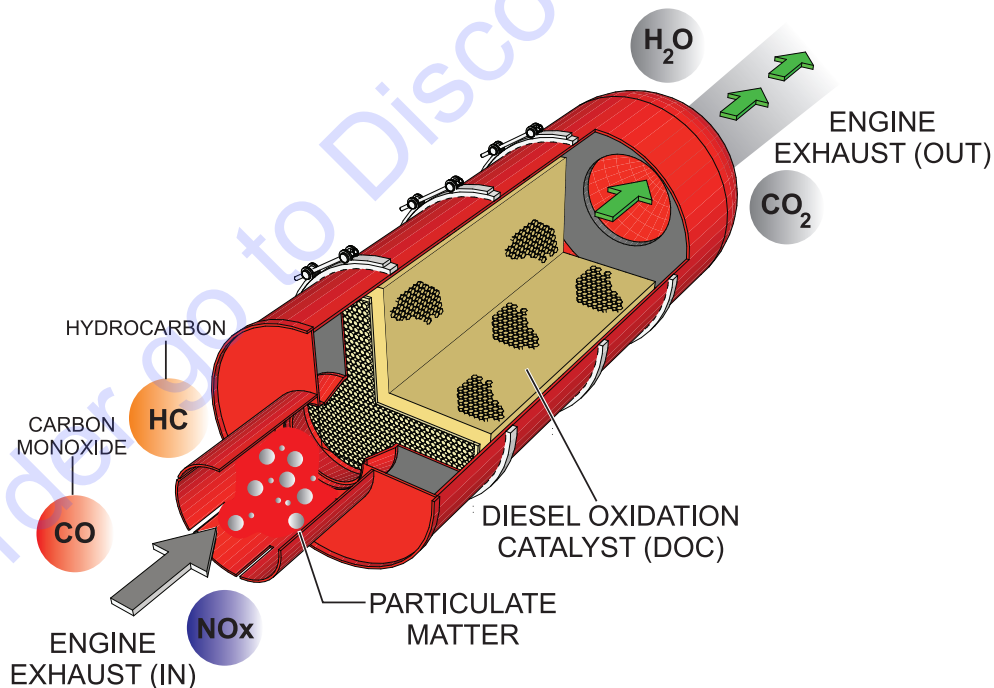

Figure 67. Diesel Oxidation Catalyst (DOC)

# TROUBLESHOOTING (DIAGNOSTICS)

The engine controller of this generator diagnoses problems (faults/errors) that arise from the engine control system and the engine itself.

When any engine faults occur during operation of the generator the **warning lamp** (diagnostic lamp) located on the control panel will turn on. If this condition occurs please perform immediately the engine fault code diagnostic procedure below.

## ENGINE FAULT CODE DIAGNOSTIC PROCEDURE

1. Remove all loads from the generator and place all circuit breakers in the **OFF** position.
2. Stop the engine.
3. Release the retaining screws that secure the control panel to the generator frame.
4. Slowly let the control panel fall forward so that the control box is exposed.
5. To start the diagnostic process, place the **diagnostic switch** to the **ON** (Figure 68) position.

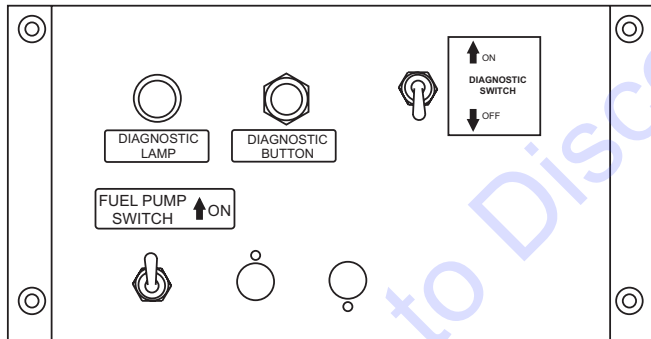

Figure 68. Diagnostic Panel

### NOTICE

Make sure to place the diagnostic switch back to the **OFF** position after completing engine fault code diagnostic procedures.

6. Verify that the **diagnostic lamp** is **ON**. This indicates that there is a fault/error in the engine or the engine control system.
7. Push and hold the **diagnostic button** to identify the fault and verify the following:
  - The diagnostic lamp will start blinking with a pattern according to the detected fault code 3 times at an interval rate of 2.4 seconds.
  - If two or more fault codes are detected the diagnostic lamp will repeat the detected fault codes' blinking patterns in ascending order. After all the detected fault codes are shown, the process will repeat starting with the first fault code.
  - If no fault is detected the diagnostic lamp will blink repeatedly at an interval rate of 2.4 seconds.

### NOTICE

For a complete understanding of error codes and troubleshooting procedures, refer to the enclosed engine instruction manual.

### NOTICE

The diagnostic lamp will indicate the current fault code with the previous fault code in ascending order.

Also when a fault is detected the fault code will automatically be saved as the previous code in the ECM even after the fault has been repaired.

### NOTICE

If a fault occurs while the engine is running the diagnostic lamp will turn on indicating only the current fault. Please note that the fault code (blinking pattern) cannot be shown while the engine is running.

## TROUBLESHOOTING (GENERATOR)

Practically all breakdowns can be prevented by proper handling and maintenance inspections, but in the event of a breakdown, use Table 10 shown below for diagnosis of the Generator. If the problem cannot be remedied, consult our company's business office or service plant.

<b>Table 10. Generator Troubleshooting</b>		
<b>Symptom</b>	<b>Possible Problem</b>	<b>Solution</b>
No Voltage Output	Defective AC voltmeter?	Check output voltage and replace if necessary.
	Loose wiring connection?	Check wiring and repair.
	Defective AVR?	Replace if necessary.
	Defective rotating rectifier?	Check and replace.
Low Voltage Output	Loose wiring connection?	Check wiring and repair.
	Defective AVR?	Replace if necessary.
High Voltage Output	Loose wiring connection?	Check wiring and repair.
	Defective AVR?	Replace if necessary.
Circuit Breaker Tripped	Short circuit in load?	Check load and repair.
	Over current?	Confirm load requirement and reduce.
	Defective circuit breaker?	Check and replace.
	Overcurrent relay actuated?	Confirm load requirement and reset.

## TROUBLESHOOTING (ENGINE)

Troubleshooting (Engine)		
Symptom	Possible Problem	Solution
Engine will not start or start is delayed, although engine can be turned over.	No Fuel reaching injection pump?	Add fuel. Check entire fuel system.
	Defective fuel pump?	Replace fuel pump.
	Fuel filter clogged?	Replace fuel filter and clean tank.
	Faulty fuel supply line?	Replace or repair fuel line.
	Compression too low?	Check piston, cylinder and valves. Adjust or repair per engine repair manual.
	Fuel pump not working correctly?	Repair or replace fuel pump.
	Oil pressure too low?	Check engine oil pressure.
	Low starting temperature limit exceeded?	Comply with cold starting instructions and proper oil viscosity.
	Defective battery?	Charge or replace battery.
	Air or water mixed in fuel system?	Check carefully for loosened fuel line coupling, loose cap nut, etc.
At low temperatures engine will not start.	Engine oil too thick?	Refill engine crankcase with correct type of oil for winter environment.
	Defective battery?	Replace battery.
Engine fires but stops soon as starter is switched off.	Fuel filter blocked?	Replace fuel filter.
	Fuel supply blocked?	Check the entire fuel system.
	Defective fuel pump?	Replace fuel pump.
Engine stops by itself during normal operation.	Fuel tank empty?	Add fuel.
	Fuel filter blocked?	Replace fuel filter.
	Defective fuel pump?	Replace fuel pump.
	Mechanical oil pressure shutdown sensor stops the engine due to low oil?	Add oil. Replace low oil shutdown sensor if necessary.
Low engine power, output and speed.	Fuel tank empty?	Replace fuel filter.
	Fuel filter clogged?	Replace fuel filter.
	Fuel tank venting is inadequate?	Ensure that tank is adequately vented.
	Leaks at pipe unions?	Check threaded pipe unions tape and tighten unions as required.
	Speed control lever does not remain in selected position?	See engine manual for corrective action.
	Engine oil level too full?	Correct engine oil level.
	Injection pump wear?	Use No. 2-D diesel fuel only. Check the fuel injection pump element and delivery valve assembly and replace as necessary.

## TROUBLESHOOTING (ENGINE)

Troubleshooting (Engine) - continued		
Symptom	Possible Problem	Solution
Low engine power output and low speed, black exhaust smoke.	Air filter blocked?	Clean or replace air filter.
	Incorrect valve clearances?	Adjust valves per engine specification.
	Malfunction at injector?	See engine manual.
Engine overheats.	Too much oil in engine crankcase?	Drain off engine oil down to uppermark on dipstick.
	Entire cooling air system contaminated/ blocked?	Clean cooling air system and cooling fin areas.
	Fan belt broken or elongated?	Change belt or adjust belt tension.
	Coolant insufficient?	Replenish coolant.
	Radiator net or radiator fin clogged with dust?	Clean net or fin carefully.
	Fan, radiator, or radiator cap defective?	Replace defective part.
	Thermostat defective?	Check thermostat and replace if necessary.
	Head gasket defective or water leakage?	Replace parts.

# GENERATOR WIRING DIAGRAM (M1814000603B)

SYMBOL	DESIGNATION
Ar	MAIN GENERATOR ARMATURE WINDING
Fg	MAIN GENERATOR FIELD WINDING
ExAr	EXCITER ARMATURE WINDING
ExFg	EXCITER FIELD WINDING
Re	RECTIFIER
AVR	AUTOMATIC VOLTAGE REGULATOR
VR	VOLTAGE REGULATOR (RHOOSTAT)
CT 1,2	CURRENT TRANSFORMER
AS	CHANGE-OVER SWITCH-AMMETER
A	AC. AMMETER
V	AC. VOLTMETER
F	FREQUENCY METER
CB1	CIRCUIT BREAKER 3P 90A
CB2,3	CIRCUIT BREAKER 2P 50A
CB4,5	CIRCUIT BREAKER 1P 20A
CON1,2	RECEPTACLE 250V 50A
CON3,4	RECEPTACLE 125V 20A*2 (G. F. C. I.)
R1	RESISTOR
Re1	RECTIFIER
•••••	••••• TERMINAL

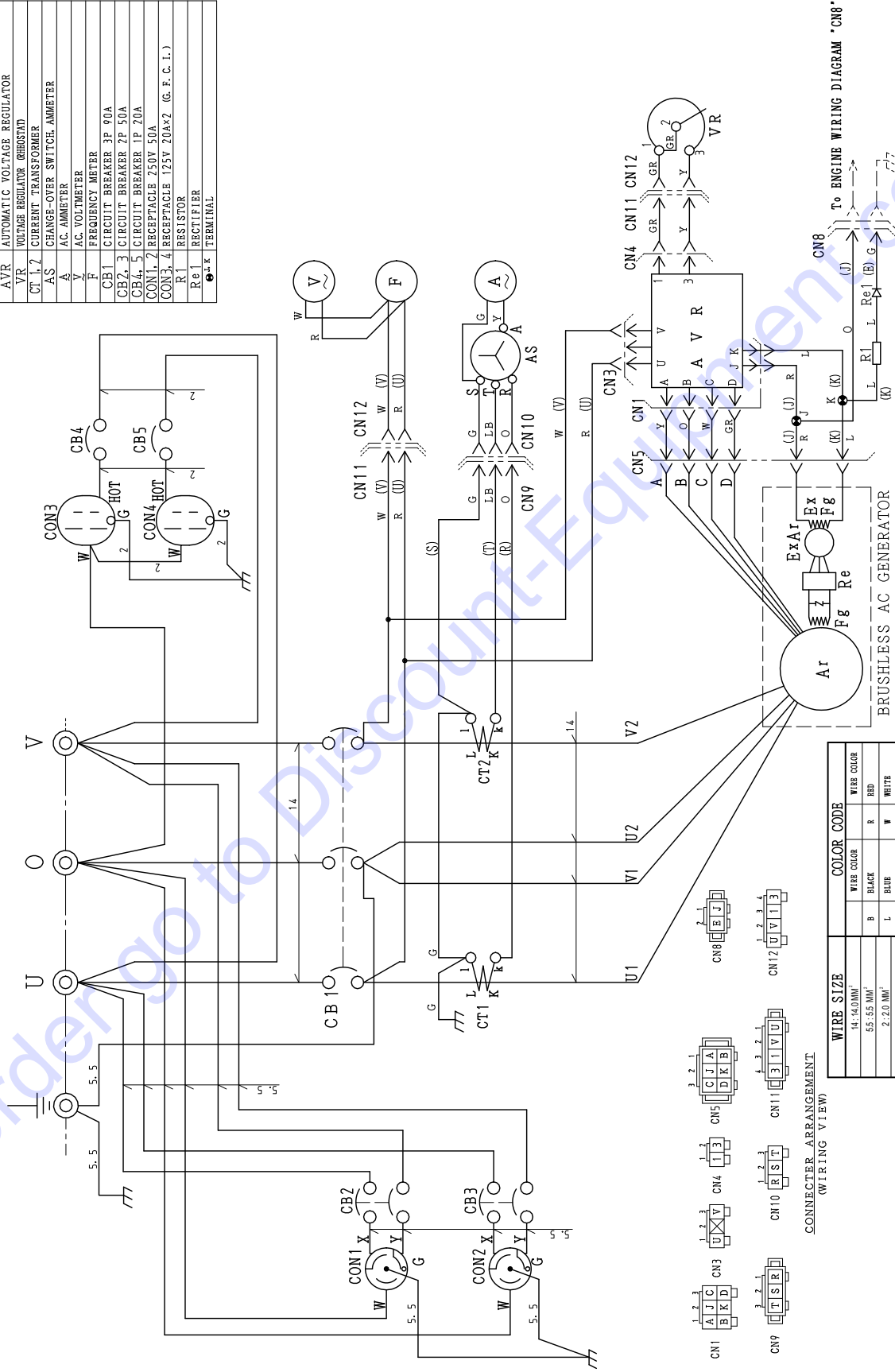

WIRE SIZE	WIRE COLOR	COLOR CODE	WIRE COLOR
14-14.0MM <sup>2</sup>	BLACK	R	RED
55-55.5MM <sup>2</sup>	BLUE	W	WHITE
2-2.0MM <sup>2</sup>	BROWN	Y	YELLOW
	GREEN	LB	LIGHT BLUE
	GRAY	LG	LIGHT GREEN
	FOURST	O	ORANGE
	PINK	P	PINK

WIRE COLOR/LINE COLOR  
 \*WIRE designation was 1.5 mm<sup>2</sup>/lead with designated color.

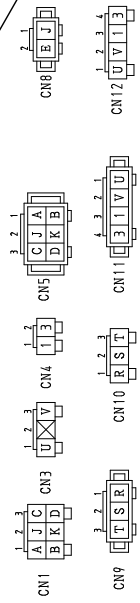

GENERATOR WIRING DIAGRAM NO. M1814000603B

# ENGINE WIRING DIAGRAM (M1814100723)

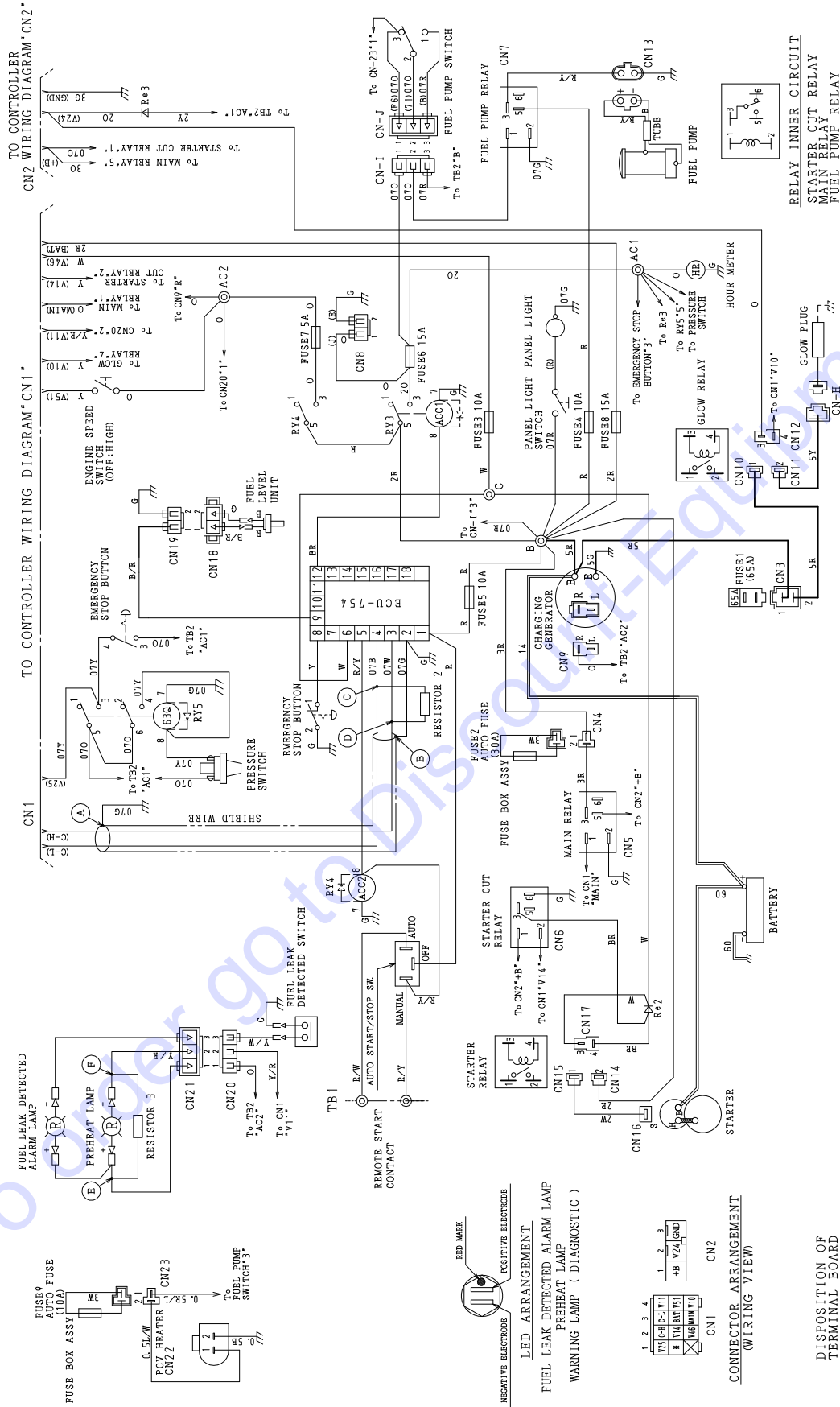

ENGINE WIRING DIAGRAM NO. M1814100723

# CONTROLLER WIRING DIAGRAM (M1814100803C)

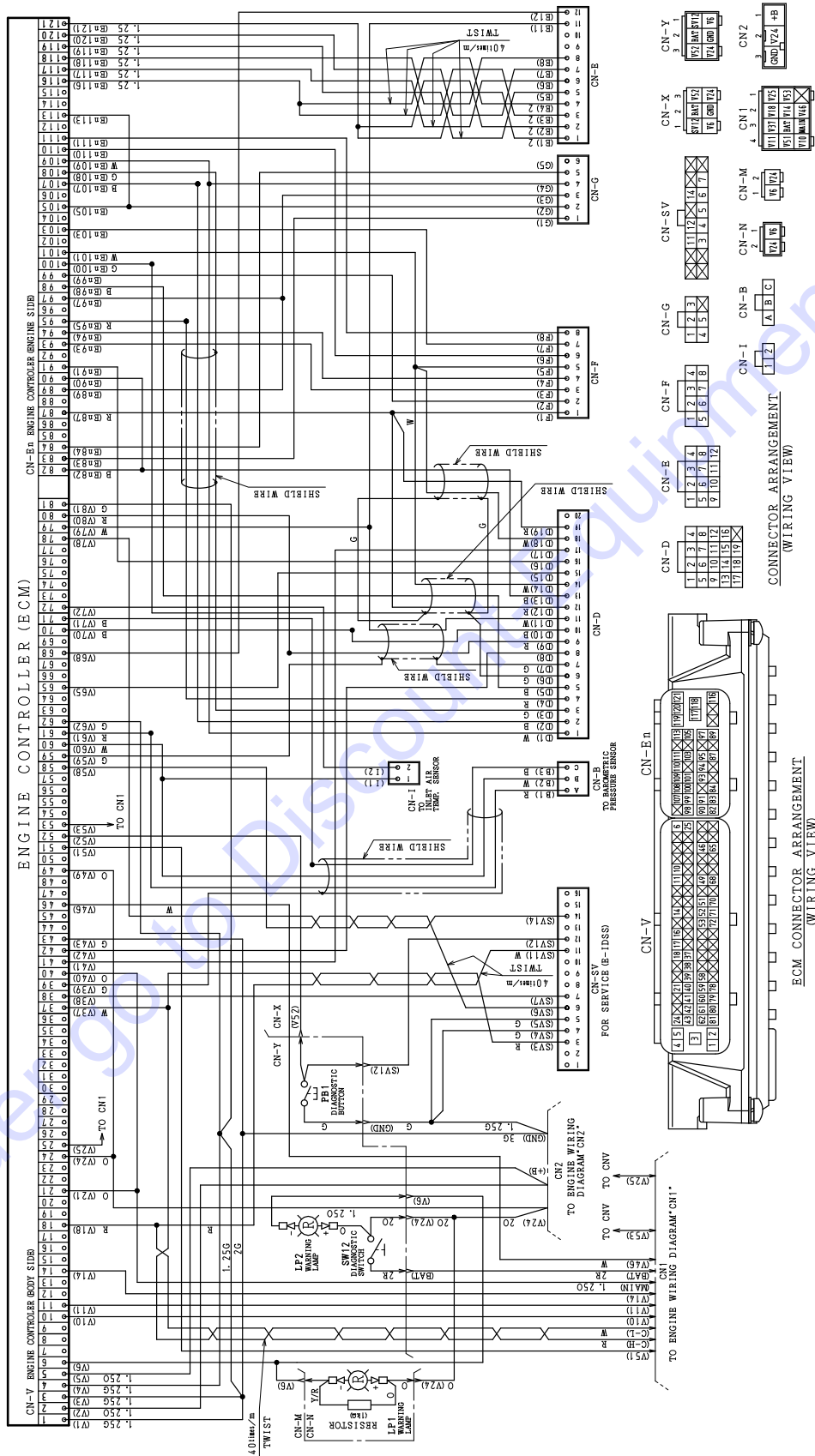

CONTROLLER WIRING DIAGRAM NO. M1814100803C

# BATTERY CHARGER WIRING DIAGRAM (OPTION)

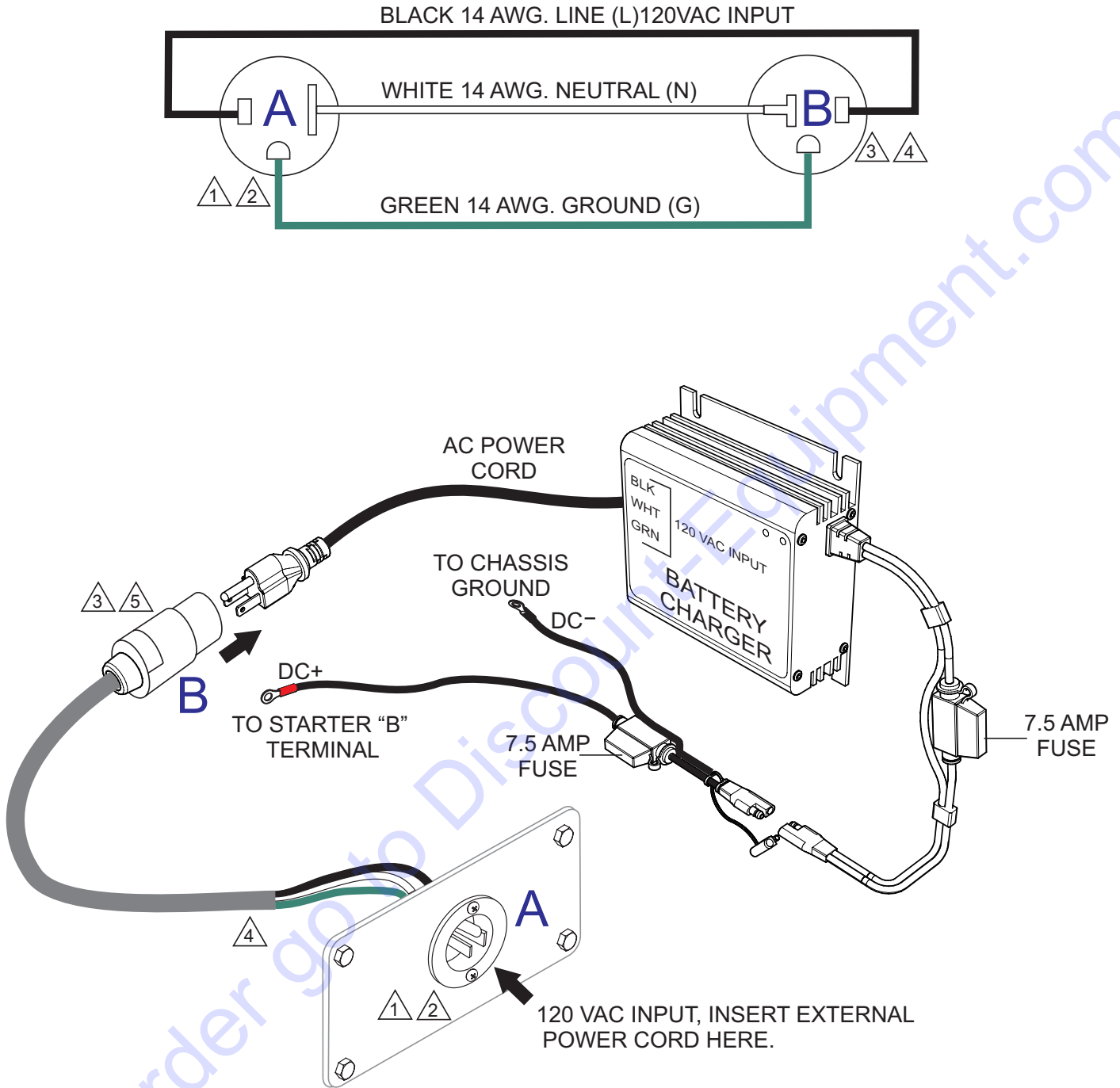

**NOTES:**

- ① NEMA 5-15, 15A, 120 VAC, P/N EE6176 (HBL5278C/HUBBLE RECEPTACLE).
- ② RECEPTACLE IS MOUNTED ON OUTPUT TERMINAL PANEL ASSY.
- ③ 20 AMP, 5-20R RECEPTACLE, P/N EE6131 (HBL5369C/HUBBLE RECEPTACLE).
- ④ CORD, CAROL 3/C 14 AWG., P/N EE56557.
- ⑤ RECEPTACLE IS MOUNTED UNDERNEATH CONTROL BOX.

# ENGINE BLOCK HEATER WIRING DIAGRAM (OPTION)

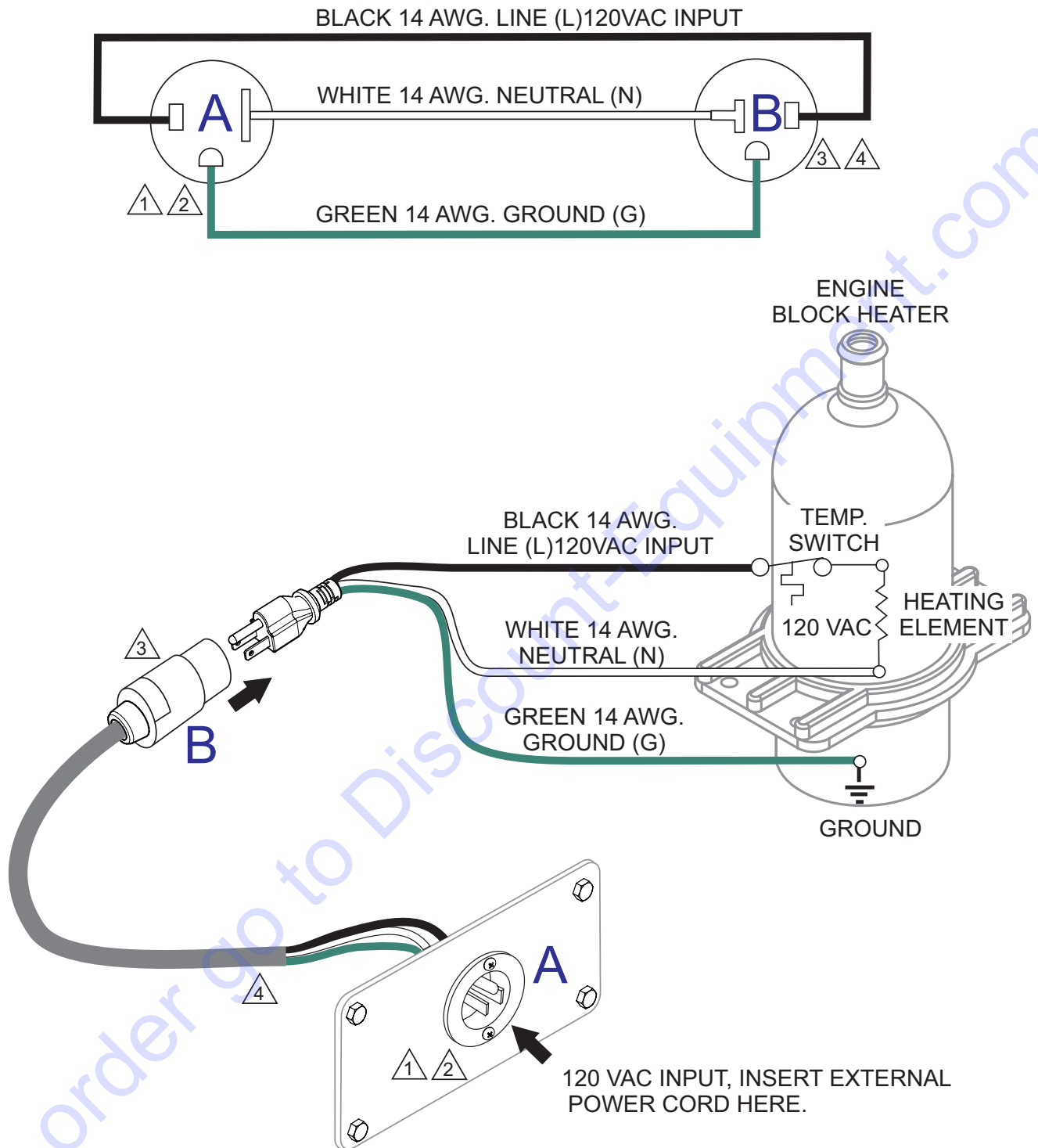

## NOTES:

- ① NEMA 5-15, 15A, 120 VAC, P/N EE6176 (HBL5278C/HUBBLE RECEPTACLE).
- ② RECEPTACLE IS MOUNTED ON OUTPUT TERMINAL PANEL ASSY.
- ③ 20 AMP, 5-20R RECEPTACLE, P/N EE6131 (HBL5369C/HUBBLE RECEPTACLE).
- ④ CORD, CAROL 3/C 14 AWG., P/N EE56557.

**TO PURCHASE THIS PRODUCT PLEASE CONTACT US**



**Equipment Financing and  
Extended Warranties Available**



**Discount-Equipment.com is your online resource for  
commercial and industrial quality parts and equipment sales.**

**561-964-4949**

**visit us on line @ [www.discount-equipment.com](http://www.discount-equipment.com)**

Select an option below to find your Equipment

**Search by Manufacturer**

**Search by Product Type**

**Request a Quote**

We sell worldwide for the brands: Genie, Terex, JLG, MultiQuip, Mikasa, Essick, Whiteman, Mayco, Toro Stone, Diamond Products, Generac Magnum, Airman, Haulotte, Barreto, Power Blanket, Nifty Lift, Atlas Copco, Chicago Pneumatic, Allmand, Miller Curber, Skyjack, Lull, Skytrak, Tsurumi, Husquvarna Target, Stow, Wacker, Sakai, Mi-T-M, Sullair, Basic, Dynapac, MBW, Weber, Bartell, Bennar Newman, Haulotte, Ditch Runner, Menegotti, Morrison, Contec, Buddy, Crown, Edco, Wyco, Bomag, Laymor, EZ Trench, Bil-Jax, F.S. Curtis, Gehl Pavers, Heli, Honda, ICS/PowerGrit, IHI, Partner, Imer, Clipper, MMD, Koshin, Rice, CH&E, General Equipment, Amida, Coleman, NAC, Gradall, Square Shooter, Kent, Stanley, Tamco, Toku, Hatz, Kohler, Robin, Wisconsin, Northrock, Oztec, Toker TK, Rol-Air, APT, Wylie, Ingersoll Rand / Doosan, Innovatech, Con X, Ammann, Mecalac, Makinex, Smith Surface Prep, Small Line, Wanco, Yanmar