

A96

APEX[®] SHOT BLASTER

OPERATING & SERVICE MANUAL



CE

A96 230V

A96 400V



Read Manual Before Operating or
Servicing Machine

405249 Rev D



TO PURCHASE THIS PRODUCT PLEASE CONTACT US



**Equipment Financing and
Extended Warranties Available**



**Discount-Equipment.com is your online resource for
commercial and industrial quality parts and equipment sales.**

561-964-4949

visit us on line @ www.discount-equipment.com

Select an option below to find your Equipment

Search by Manufacturer

Search by Product Type

Request a Quote

We sell worldwide for the brands: Genie, Terex, JLG, MultiQuip, Mikasa, Essick, Whiteman, Mayco, Toro Stone, Diamond Products, Generac Magnum, Airman, Haulotte, Barreto, Power Blanket, Nifty Lift, Atlas Copco, Chicago Pneumatic, Allmand, Miller Curber, Skyjack, Lull, Skytrak, Tsurumi, Husquvarna Target, Stow, Wacker, Sakai, Mi-T-M, Sullair, Basic, Dynapac, MBW, Weber, Bartell, Bennar Newman, Haulotte, Ditch Runner, Menegotti, Morrison, Contec, Buddy, Crown, Edco, Wyco, Bomag, Laymor, EZ Trench, Bil-Jax, F.S. Curtis, Gehl Pavers, Heli, Honda, ICS/PowerGrit, IHI, Partner, Imer, Clipper, MMD, Koshin, Rice, CH&E, General Equipment, Amida, Coleman, NAC, Gradall, Square Shooter, Kent, Stanley, Tamco, Toku, Hatz, Kohler, Robin, Wisconsin, Northrock, Oztec, Toker TK, Rol-Air, APT, Wylie, Ingersoll Rand / Doosan, Innovatech, Con X, Ammann, Mecalac, Makinex, Smith Surface Prep, Small Line, Wanco, Yanmar

Table of Contents

| | |
|--|-----------|
| Table of Contents | 2 |
| Description | 4 |
| Specifications | 5 |
| Safety | 6 |
| Safety Warnings Used in Manual..... | 6 |
| Safety Labels Placed on Machine | 7 |
| General Rules for Safe Operation | 8 |
| Shot Blaster Safety Guidelines | 9 |
| Electrical Practices | 10 |
| Components and Assembly | 12 |
| Operating Controls..... | 12 |
| Separator | 14 |
| Shot Valve..... | 14 |
| Blast Wheel Drive | 15 |
| Blast Head Seals | 15 |
| Front Wheel Drive..... | 16 |
| Cord Manager..... | 16 |
| Shot Selection..... | 17 |
| Airflow | 18 |
| Manually Moving the Machine | 19 |
| Hoisting the Machine | 20 |
| Transporting the Machine with Vehicle | 20 |
| Operation | 21 |
| Cleaning Debris from Hopper | 21 |
| Adding Shot | 21 |
| Securing the Power Cord and Dust Hose..... | 22 |
| Verifying the Correct Motor Direction..... | 22 |
| Preparing for Operation | 23 |
| Startup Procedure..... | 24 |
| Engaging the Front Wheel Drive..... | 24 |
| Starting the Machine..... | 24 |
| Adjusting the Blast Pattern | 26 |
| Working Direction | 28 |
| Travel Speed..... | 28 |
| Adjusting the Height of Magnets and Brushes..... | 29 |
| Turning Off the Machine | 30 |
| Emergency Stop | 30 |
| Preparing the Machine for Transport or Storage | 30 |
| Troubleshooting Guide | 31 |
| General Errors | 31 |
| Electrical Errors | 32 |
| Maintenance Schedule | 33 |
| Maintenance and Inspection List | 33 |
| Maintenance Intervals..... | 33 |
| Maintenance | 35 |
| Removing the Blast Wheel | 35 |
| Replacing the Blast Wheel..... | 35 |
| Removing the Liners..... | 36 |
| Replacing the Liners | 36 |
| Belt Drive | 38 |
| Chain Drive | 40 |
| Filter Maintenance | 41 |
| Replacing Work Lights..... | 42 |
| Replacing Fuse..... | 42 |
| Removing the Shot Valve Control Cable | 43 |
| Replacing the Shot Valve Control Cable..... | 43 |
| Setting the Amperage | 44 |
| Recommended Spare Parts List..... | 45 |

Table of Contents

| | |
|--|-----------|
| Parts List and Diagrams | 46 |
| Overall | 46 |
| Liners | 47 |
| Blast Wheel Drive and Cord Manager | 48 |
| Separator and Shot Valve | 52 |
| Plenums | 54 |
| Rear Wheels | 55 |
| Magnets, Brushes and Rear Seal | 56 |
| Handle and Joystick | 58 |
| Front Wheel Drive | 60 |
| Electrical Collector - 405244 | 62 |
| 230V Control Box - 405063 | 64 |
| 230V Sub-Panel Assembly - 405064 | 65 |
| 230V Power Cord - 405246 | 66 |
| 230V Wiring Diagrams | 67 |
| 400V Control Box - 405770 | 70 |
| 400V Sub-Panel Assembly - 405769 | 71 |
| 400V Power Cord - 405614 | 72 |
| 400V Wiring Diagrams | 73 |
| Warranty | 77 |

Description

MACHINE DESCRIPTION

The A96 shot blaster is designed to shot blast concrete surfaces and either remove material from the concrete surface or texture the concrete surface so material can adhere to the concrete—these steps can sometimes happen concurrently. Removing mastic or epoxy may plug the machine. The machine may be operated indoors or outdoors and can be operated in dusty conditions. The machine must not be operated in precipitation (rain or snow).

An appropriate dust collector must be connected to the machine in order to separate the dust from the shot.



FEATURES

1. **Adjustable Handle** - Provides ergonomic adjustability.
2. **Joystick** - Provides convenient access to drive controls.
3. **Front Wheel Drive** - Allows for easy maneuverability and control.
4. **8" Blast Pattern** - Allows a blasting capacity up to 861 ft²/hr.
5. **Curved Rebound Plenum** - Allows for efficient shot flow and removal of dust and debris.
6. **In-Line Air Wash Separation System** - Maximizes separation of dust from the reclaimed shot resulting in prolonged part life.
7. **Shot Control Lever** - Precision heavy-duty shot flow control lever.
8. **Rear-Facing Vacuum Port** - Improves airflow during operation.
9. **Cord Manager** - Conveniently clamps power cord and dust hose to help prevent tangling.
10. **Front Work Lights** - Illuminate the unblasted surface.
11. **Rear Work Lights** - Illuminate the blasted surface.

Specifications

| Product Specifications | | | | | | |
|------------------------|------------------|----------------|-----------------------|---------------|-------------------------------|---------------|
| Width | Length | Height | Weight | Working Width | Blasting Capacity | Power |
| 13.5" (34.3 cm) | 57.5" (146.1 cm) | 44" (111.8 cm) | 349 lbs (158.3 kg) | 8" (20.3 cm) | Up to 861 ft ² /hr | 5.3 HP (4 kW) |

| Machine Variants | | | |
|-----------------------------|---------------|----------------------|---------------------------|
| Region | Serial Number | Max. Operating Amps* | Input Power** |
| Domestic (North America) | A96-10XXXX | 25A | 230V, 1 Phase, 60 Hz, 30A |
| International | A96-11XXXX | 9A | 400V, 3 Phase, 50 Hz, 16A |

*Indicates the maximum amp draw under typical conditions.

**Indicates the expected source/supply connection rating.

Power Cord (Included):

- 405246 (A96 230V)
- 405614 (A96 400V)

Recommended Dust Collector: DL3000 or DL4000

Safety

SAFETY WARNINGS USED IN MANUAL

Look for the safety hazard warning symbol.



This symbol is used to alert the operator of safety hazards. It is used along with the words DANGER, WARNING and CAUTION.



“DANGER” identifies immediate hazards which will result in serious injury or death.



“WARNING” identifies potential hazards which could result in serious injury or death.



“CAUTION” identifies hazardous situations which may result in minor injury and/or could result in damage or destruction of equipment.

SAFETY LABELS PLACED ON MACHINE



Pinch Point Hazard



Shock Hazard



Burn Hazard



Ear Protection Warning



Eye Protection Warning



Silica Dust Warning
Possible Asbestos Exposure
Warning

GENERAL RULES FOR SAFE OPERATION

Before use, anyone operating or performing maintenance on this equipment must read and understand this manual, as well as any labels packaged with or attached to the machine and its components. Read the manual carefully to learn equipment applications and limitations, as well as potential hazards associated with this type of equipment. Keep manual near machine at all times. If your manual is lost or damaged, contact Discount-equipment for a replacement.

Personal

Dress properly and use safety gear.

Anyone in the work area is required to wear eye protection, hearing protection, a dust mask and safety shoes. Hard hats, face shields, etc. should be worn when specified or necessary. Do not wear loose clothing; it may be caught in moving parts.

Maintain control; stay alert.

Keep proper footing and balance, and maintain a firm grip. Observe surroundings at all times. Do not use when tired, distracted, or under the influence of drugs, alcohol, or any medication that may cause decreased control.

Keep hands away from all moving parts and tooling.

Wear gloves when changing tooling.

Do not force equipment.

Equipment will perform best at the rate for which it was designed. Excessive force only causes operator fatigue, increased wear, and reduced control.

Environment

Avoid use in dangerous environments.

Do not use in rain, damp or wet locations, or in the presence of explosive atmospheres (gaseous fumes, dust, or flammable materials). Remove materials or debris that may be ignited by sparks. Keep work area tidy and well-lit - a cluttered or dark work area may lead to accidents.

Protect others in the work area and be aware of surroundings.

Provide barriers or shields as needed to protect others from debris and machine operation. Children and other bystanders should be kept at a safe distance from the work area to avoid distracting the operator and/or coming into contact with the machine. Operator should be aware of who is around them and their proximity. Support personnel should never stand next to, in front of, or behind the machine while the machine is running. Operator should look behind them before backing up.

Guard against electric shock.

Ensure that machine is connected to a properly grounded outlet. Prevent bodily contact with grounded surfaces, e.g. pipes, radiators, ranges, and refrigerators.

Maintenance & Repairs

Begin maintenance work only when the machine is shut down, unplugged, and cooled down. Maintenance work should only be performed by qualified personnel.

Use proper cleaning agents.

Ensure that all cleaning rags are fiber-free; do not use any aggressive cleaning products.

Schedule regular maintenance check-ups.

Ensure machine is properly cleaned and serviced. Remove all traces of oil, combustible fuel, or cleaning fluids from the machine and its connections and fittings. Retighten all loose fittings found during maintenance and repair work. Loose or damaged parts should be replaced immediately; use only NFE parts.

Do not weld or flame-cut on the machine during repairs, or make changes to machine without authorization from NFE.

Equipment

Use proper parts and accessories.

Only use NFE-approved or recommended parts and accessories. Using any that are not recommended may be hazardous.

Ensure accessories are properly installed and maintained.

Do not permanently remove a guard or other safety device when installing an accessory or attachment.

Inspect for damaged parts.

Check for misalignment, binding of moving parts, loose fasteners, improper mounting, broken parts, and any other conditions that may affect operation. If abnormal noise or vibration occurs, turn the machine off immediately. Do not use damaged equipment until repaired. Do not use if power switch does not turn machine on and off. For all repairs, insist on only identical NFE replacement parts.

Maintain equipment and labels.

Keep handles dry, clean, and free from oil and grease. Keep cutting edges sharp and clean. Follow instructions for lubricating and changing accessories. Motor and switches should be completely enclosed at all times with no exposed wiring. Inspect cord regularly. Labels carry important information; if unreadable or missing, contact Discount-equipment for a free replacement.

Avoid accidental starting; store idle equipment.

When not in use, ensure that the machine is unplugged; do not turn on before plugging in. Store in a dry, secured place. Remove tooling when storing, and keep away from children.

Safety

SHOT BLASTER SAFETY GUIDELINES

Before use, anyone operating this equipment must read and understand these safety instructions.

Shot Blasting

Beware of hidden protrusions.

Watch out for hidden dangers and protrusions in flooring. Do not use on largely uneven surfaces.

Provide barriers, shields, or safety glasses as needed to protect others from debris.

Use for correct applications.

Do not force equipment to do heavier duty work than it was made for.

Use a magnetic sweep immediately after blasting.

Steel shot that is left on the walking surfaces creates a slipping hazard which could cause unexpected falls.

Dust Collection

Turn off machine before working with dust collector.

Do not switch off or remove the dust collector while the machine is running.

Use with appropriate dust collecting system.

Do not operate machine designed for use with a dust collector without the dust collector. Ensure dust collector is on and operating properly while grinding.

Dispose of collected waste.

Do not leave the dust collector bag full of waste. Handle and dispose of bag and waste in accordance with all applicable local, state, and federal regulations. The dust bin of a connected dust collector must be emptied before transportation.



WARNING: AVOID CONTACT WITH THE HOT PLENUMS. DO NOT TOUCH PLENUMS WITHOUT PROPER HAND PROTECTION. THE PLENUMS BECOME HOT DURING OPERATION AND REMAIN HOT AFTER STOPPING THE MACHINE.

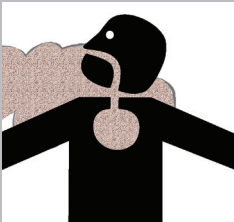

WARNING: GRINDING/CUTTING/DRILLING OF MASONRY, CONCRETE, METAL AND OTHER MATERIALS CAN GENERATE DUST, MISTS AND FUMES CONTAINING CHEMICALS KNOWN TO CAUSE SERIOUS FATAL INJURY OR ILLNESS, SUCH AS RESPIRATORY DISEASE, CANCER, BIRTH DEFECTS OR OTHER REPRODUCTIVE HARM. IF YOU ARE UNFAMILIAR WITH THE RISKS ASSOCIATED WITH THE PARTICULAR MATERIAL BEING CUT, REVIEW THE MATERIAL SAFETY DATA SHEET AND/OR CONSULT YOU EMPLOYER, THE MATERIAL MANUFACTURER/SUPPLIER, GOVERNMENTAL AGENCIES SUCH AS OSHA AND NIOSH AND OTHER AUTHORITIES ON HAZARDOUS MATERIALS. CALIFORNIA AND SOME OTHER AUTHORITIES, FOR INSTANCE, HAVE PUBLISHED LISTS OF SUBSTANCES KNOWN TO CAUSE CANCER, REPRODUCTIVE TOXICITY, OR OTHER HARMFUL EFFECTS. CONTROL DUST, MIST AND FUMES AT THE SOURCE WHERE POSSIBLE. IN THIS REGARD USE GOOD WORK PRACTICES AND FOLLOW THE RECOMMENDATIONS OF THE MANUFACTURER/SUPPLIER, OSHA/NIOSH, AND OCCUPATIONAL AND TRADE ASSOCIATIONS. WHEN THE HAZARDS FROM INHALATION OF DUST, MISTS AND FUMES CANNOT BE ELIMINATED, THE OPERATOR AND ANY BYSTANDERS SHOULD ALWAYS WEAR A RESPIRATOR APPROVED BY OSHA/MSHA FOR THE MATERIAL BEING CUT.

ELECTRICAL PRACTICES



WARNING: ELECTRICAL CORDS CAN BE HAZARDOUS. MISUSE CAN RESULT IN FIRE OR DEATH BY ELECTRICAL SHOCK. READ CAREFULLY AND FOLLOW ALL DIRECTIONS.



CAUTION: ALWAYS FOLLOW APPLICABLE ELECTRICAL CODES, STANDARDS AND/OR REGULATIONS. CONSULT YOUR LOCAL ELECTRICAL AUTHORITY OR A LICENSED ELECTRICIAN BEFORE ATTEMPTING TO MODIFY AN ELECTRICAL INSTALLATION. ENSURE THAT CIRCUIT AND GROUND FAULT PROTECTION DEVICES AND ALL OTHER ELECTRICAL SAFETY EQUIPMENT ARE FUNCTIONING PROPERLY.

Extension Cord Requirements

- Ensure the cord type is suitable for the application and location. If you are unsure about your cord type, consult a qualified electrical professional or electrician.
- Ground your equipment. The equipment must be plugged into an appropriate outlet, one which is properly installed and grounded in accordance with all codes and ordinances. Do NOT modify the plug provided with the equipment. Never remove the grounding prong from the plug.
- Do not remove, bend or modify any metal prongs or pins of the plug. Modifications to power cords and/or plugs may result injury and/or equipment damage.
- FULLY INSERT plug into outlet.
- Do not use excessive force to make connections.
- Never unplug by pulling the cord from the outlet. Pull plug rather than cord to reduce the risk of damage.
- Regularly examine your extension cord and ensure it is in good electrical condition. Never use a damaged cord—either replace it or have it repaired by a qualified person.
- Protect your extension cords from sharp objects, excessive heat and damp or wet areas. Keep the cord away from oil, cutting edges and moving parts.
- Do not drive, drag or place objects over cord.
- Avoid overheating. Uncoil cord and do not cover it with any material.
- Avoid accidental starting. Be sure equipment is turned off before plugging in. Do not use equipment if the power switch does not turn the equipment on and off.
- Make sure equipment is not running before disconnecting cord.
- Unplug equipment. When not in use and before changing accessories or performing maintenance, unplug the machine.

Extension Cord Selection

All cords should be sized appropriately to reduce the risk of damage, fire or reduced performance. Reference the tables in this section for cord sizes.

How to Use the Tables

1. Determine the phase, then choose the proper table.
2. Determine your supply voltage.
3. Determine the total length of your cord including all extension cords.
4. Determine the maximum amp draw for your machine.
5. Trace your voltage across the top of the table to the first length that is greater than or equal to your cord length.

Safety

ELECTRICAL PRACTICES—CONTINUED

- Follow the column down to the first row that contains a maximum amp draw greater than or equal to yours.
- This cell contains the minimum wire size for your application.

Example

Application: Max Amps = 11A, Length = 80ft, Voltage = 230V

Solution: 80ft is between the 50ft and 100ft columns, so the larger of the two columns is chosen. Likewise, 11A is between the 10A and 12A rows, so the larger of the two rows is chosen. 14 AWG (2.5mm²) is the minimum wire size for this example.

| | | Single Phase Equipment | | | |
|------------|-------------|------------------------------|------------------------------|------------------------------|------------------------------|
| Max Length | 120V Supply | 25ft (7.5m) | 50ft (15m) | 75ft (25m) | |
| | 230V Supply | 50ft (15m) | 100ft (30m) | 150ft (45m) | |
| Max Amps | | Minimum Wire Size | | | |
| 8 | | 16 AWG (1.5mm ²) | 16 AWG (1.5mm ²) | 16 AWG (1.5mm ²) | 16 AWG (1.5mm ²) |
| 10 | | 16 AWG (1.5mm ²) | 16 AWG (1.5mm ²) | 16 AWG (1.5mm ²) | 16 AWG (1.5mm ²) |
| 12 | | 14 AWG (2.5mm ²) | 14 AWG (2.5mm ²) | 14 AWG (2.5mm ²) | 14 AWG (2.5mm ²) |
| 14 | | 14 AWG (2.5mm ²) | 14 AWG (2.5mm ²) | 14 AWG (2.5mm ²) | 14 AWG (2.5mm ²) |

Extension Cord Sizes

| Single Phase Equipment | | | | | | | |
|------------------------|-------------|------------------------------|------------------------------|------------------------------|------------------------------|------------------------------|------------------------------|
| Max Length | 120V Supply | 25ft (7.5m) | 50ft (15m) | 75ft (25m) | 100ft (30m) | 150ft (45m) | 200ft (60m) |
| | 230V Supply | 50ft (15m) | 100ft (30m) | 150ft (45m) | 200ft (60m) | 300ft (90m) | 400ft (120m) |
| Max Amps | | Minimum Wire Size | | | | | |
| 8 | | 16 AWG (1.5mm ²) | 16 AWG (1.5mm ²) | 16 AWG (1.5mm ²) | 16 AWG (1.5mm ²) | 14 AWG (2.5mm ²) | 14 AWG (2.5mm ²) |
| 10 | | 16 AWG (1.5mm ²) | 16 AWG (1.5mm ²) | 16 AWG (1.5mm ²) | 16 AWG (1.5mm ²) | 14 AWG (2.5mm ²) | 12 AWG (4mm ²) |
| 12 | | 14 AWG (2.5mm ²) | 14 AWG (2.5mm ²) | 14 AWG (2.5mm ²) | 14 AWG (2.5mm ²) | 12 AWG (4mm ²) | 12 AWG (4mm ²) |
| 14 | | 14 AWG (2.5mm ²) | 14 AWG (2.5mm ²) | 14 AWG (2.5mm ²) | 14 AWG (2.5mm ²) | 12 AWG (4mm ²) | 10 AWG (6mm ²) |
| 16 | | 14 AWG (2.5mm ²) | 14 AWG (2.5mm ²) | 14 AWG (2.5mm ²) | 14 AWG (2.5mm ²) | 12 AWG (4mm ²) | 10 AWG (6mm ²) |
| 18 | | 14 AWG (2.5mm ²) | 14 AWG (2.5mm ²) | 14 AWG (2.5mm ²) | 12 AWG (4mm ²) | 12 AWG (4mm ²) | 10 AWG (6mm ²) |
| 20 | | 12 AWG (4mm ²) | 12 AWG (4mm ²) | 12 AWG (4mm ²) | 12 AWG (4mm ²) | 10 AWG (6mm ²) | 10 AWG (6mm ²) |
| 25 | | 12 AWG (4mm ²) | 12 AWG (4mm ²) | 12 AWG (4mm ²) | 12 AWG (4mm ²) | 10 AWG (6mm ²) | 8 AWG (10mm ²) |
| 30 | | 10 AWG (6mm ²) | 10 AWG (6mm ²) | 10 AWG (6mm ²) | 10 AWG (6mm ²) | 8 AWG (10mm ²) | 8 AWG (10mm ²) |

| 3 Phase Equipment | | | | | | | |
|-------------------|-------------|-----------------------------|-----------------------------|-----------------------------|-----------------------------|-----------------------------|-----------------------------|
| Max Length | 230V Supply | 25ft (7.5m) | 50ft (15m) | 75ft (25m) | 100ft (30m) | 150ft (45m) | 200ft (60m) |
| | 400V Supply | 40ft (12m) | 80ft (25m) | 120ft (35m) | 160ft (50m) | 250ft (75m) | 325ft (100m) |
| | 480V Supply | 50ft (15m) | 100ft (30m) | 150ft (45m) | 200ft (60m) | 300ft (90m) | 400ft (120m) |
| Max Amps | | Minimum Wire Size | | | | | |
| 20 | | 10 AWG (6mm ²) | 10 AWG (6mm ²) | 10 AWG (6mm ²) | 10 AWG (6mm ²) | 10 AWG (6mm ²) | 10 AWG (6mm ²) |
| 30 | | 8 AWG (10mm ²) | 8 AWG (10mm ²) | 8 AWG (10mm ²) | 8 AWG (10mm ²) | 8 AWG (10mm ²) | 8 AWG (10mm ²) |
| 40 | | 6 AWG (16mm ²) | 6 AWG (16mm ²) | 6 AWG (16mm ²) | 6 AWG (16mm ²) | 6 AWG (16mm ²) | 6 AWG (16mm ²) |
| 50 | | 4 AWG (25mm ²) | 4 AWG (25mm ²) | 4 AWG (25mm ²) | 4 AWG (25mm ²) | 4 AWG (25mm ²) | 4 AWG (25mm ²) |
| 60 | | 4 AWG (25mm ²) | 4 AWG (25mm ²) | 4 AWG (25mm ²) | 4 AWG (25mm ²) | 4 AWG (25mm ²) | 4 AWG (25mm ²) |
| 70* | | 6 AWG (16mm ²)* | 6 AWG (16mm ²)* | 6 AWG (16mm ²)* | 6 AWG (16mm ²)* | 6 AWG (16mm ²)* | 6 AWG (16mm ²)* |
| 80* | | 4 AWG (25mm ²)* | 4 AWG (25mm ²)* | 4 AWG (25mm ²)* | 4 AWG (25mm ²)* | 4 AWG (25mm ²)* | 4 AWG (25mm ²)* |
| 90* | | 4 AWG (25mm ²)* | 4 AWG (25mm ²)* | 4 AWG (25mm ²)* | 4 AWG (25mm ²)* | 4 AWG (25mm ²)* | 4 AWG (25mm ²)* |
| 100* | | 4 AWG (25mm ²)* | 4 AWG (25mm ²)* | 4 AWG (25mm ²)* | 4 AWG (25mm ²)* | 4 AWG (25mm ²)* | 4 AWG (25mm ²)* |

* 75°C TYPE W CORD OR EQUIVALENT

Note: Tables are based on a <10% voltage loss, data from the U.S. National Electrical Code Tables 400.5(A) & 400.5(B) and typical resistances for copper wire.

THIS PAGE INTENTIONALLY LEFT BLANK

To order go to Discount-Equipment.com

Components and Assembly

OPERATING CONTROLS

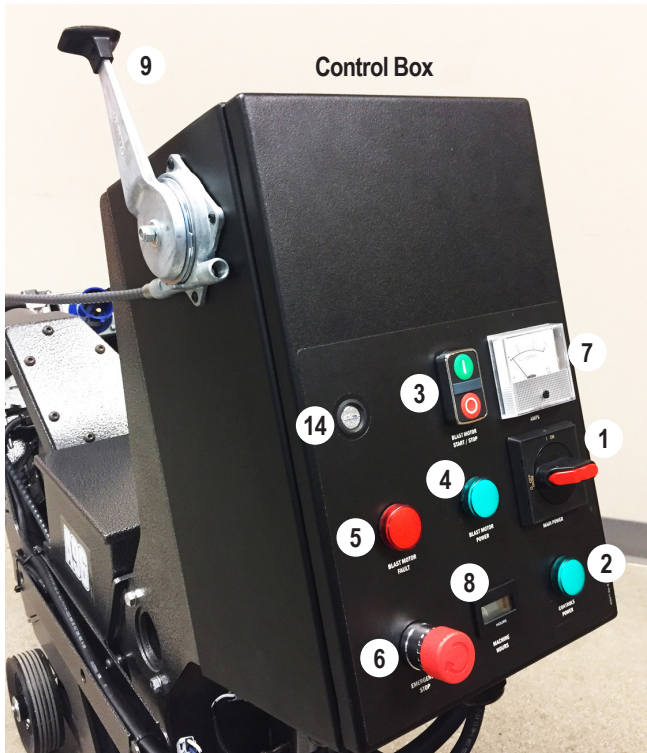

Components and Assembly

OPERATING CONTROLS (FIGURES 1-2)

Main Power Switch (1)

Must be switched ON before starting operation.

Main Power Indicator (2)

Indicates the main power switch is turned ON.

Blast Wheel Start/Stop Buttons (3)

Pushing the START button starts the blast wheel motor, pushing the STOP button stops the motor.

Blast Wheel Power Indicator (4)

Indicates the blast wheel motor is ON.

Blast Motor Fault Indicator (5) – 230V Machine Only

Indicates a fault in the blast motor circuit.

Emergency Stop Switch (6)

In case of an emergency push the emergency stop switch to simultaneously deactivate the blast wheel motor and front wheel drive motor. To release the emergency stop switch, twist the red button and pull it upwards.

***A96 230V Machine Only:** If the emergency stop switch is released while the main power switch is ON, the blast wheel STOP button must be pushed before the blast motor can be restarted.*

Ammeter (7)

Indicates the total amp draw of the machine. The reading increases as the shot valve is opened. See Specifications section for the maximum operating amps rating.

Hour Meter (8)

Displays the actual working hours performed by the blast wheel.

Shot Control Lever (9)

Controls the shot valve which regulates the flow of shot to the blast wheel. The shot throughput is set by changing the lever position. Pushing the lever opens the feed valve, pulling the lever closes the valve.

Shot Valve Stop (Not Shown)

Limits the maximum opening setting of the shot valve.

Speed Control (10)

Controls the drive speed. Scales between 1-10 to indicate relative speed. Allows operator to set the appropriate speed.

Drive Trigger (11)

Pulling the drive trigger moves the machine forward. Pushing the reverse button with the drive trigger pulled moves the machine in reverse.

Reverse Button (12)

Pushing the reverse button (blue) with the drive trigger pulled moves the machine in reverse.

Overdrive Button (13)

Pushing the overdrive button (gray) while driving in forward or reverse bypasses the speed control and moves the machine at maximum speed. Used to move quickly between work areas, not to be used while shot blasting.

Latch (14)

To open the control box door, use a slotted screwdriver to unlock the latch.

Front and Rear Work Lights (Not Shown)

Front work lights illuminate the unblasted surface, rear work lights illuminate the blasted surface.

Components and Assembly

SEPARATOR (FIGURE 3)

The separator is mounted to the end of the rebound plenum. The deflector (1) and flap (2) stop the deflected shot. The lid (3) seals the separator. The dust collector, connected to the hose connector (4), generates the appropriate airflow within the separator to separate dust from the shot.

The shot passes through the wire mesh tray (5) and drops back into the hopper. The mesh tray prevents coarse contaminants from getting to the blast wheel. The mesh tray can be pulled from the side of the separator for cleaning.

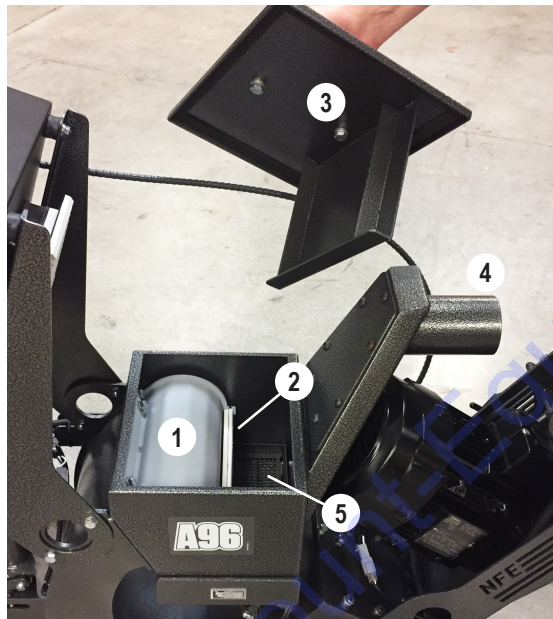

FIG. 3

SHOT VALVE (FIGURE 4-5)

The shot valve (1) regulates the flow of shot to the blast wheel and is located between the hopper (2) and the feed spout (3). The valve is controlled by the shot control lever via the control cable (4). Maximum feed occurs with the shot lever completely pushed forward. The shot valve stop (5) limits the maximum opening of the shot valve if needed.

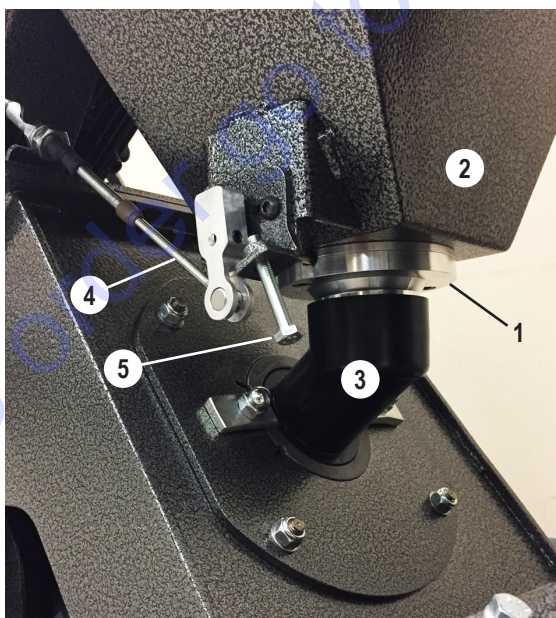

FIG. 4

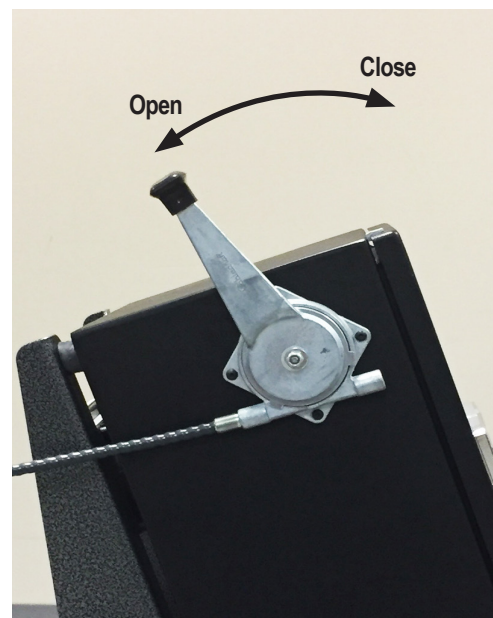

FIG. 5

Components and Assembly

BLAST WHEEL DRIVE (FIGURE 6)

The blast wheel (1) throws shot at the surface to be treated. It is surrounded by replaceable liners (2) and is driven by an electric motor (3) via the wheel hub (4). Shot is fed to the blast wheel through the feed spout (5).

The position of the control cage (5) determines the direction shot is thrown to the surface and the evenness of the blast pattern.

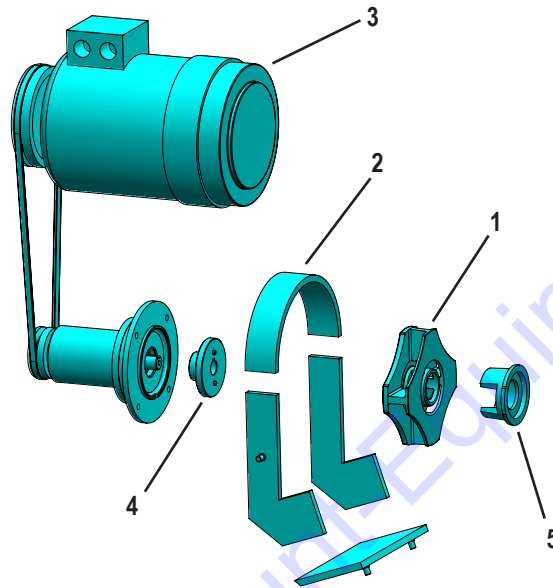

FIG. 6

BLAST HEAD SEALS (FIGURE 7)

On the front and sides of the blast head opening are magnets (1) surrounded by brushes (2). On the rear side is a drag seal (3). The magnets, brushes and drag seal regulate the airflow inside the machine and seal against shot spraying out from the blast head. Airflow enters the machine through the drag seal and travels through the plenum carrying shot and dust upwards to the separator.

The correct height adjustment is .13-.38" (3-10 mm) from the bottom of the magnets to the surface and is important for optimum machine performance. In general, the magnets should be set at the maximum height of .38" (10 mm) for very rough surfaces and set at the minimum height of .13" (3 mm) for very smooth surfaces. See Adjusting the Height of Magnets and Brushes section for the adjustment procedure.

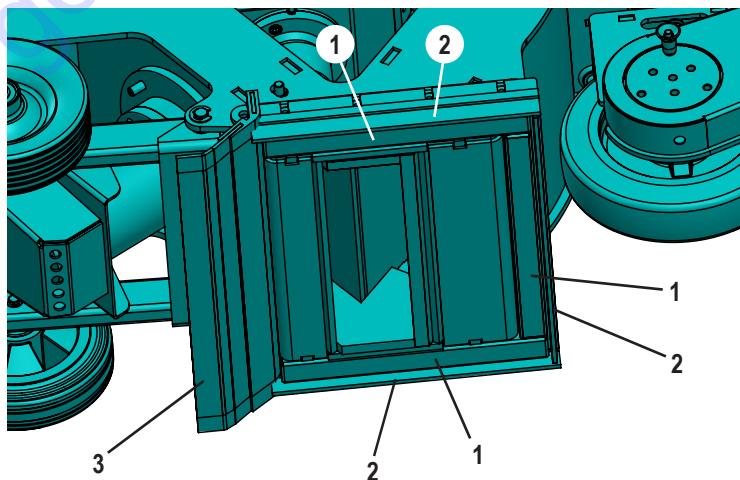

FIG. 7

Components and Assembly

FRONT WHEEL DRIVE (FIGURE 8)

The machine is driven by an electric drive motor which transmits power via a chain drive to the drive sprocket. A quick release pin (1) directly connects the drive sprocket to the drive wheel.

Note: The quick release pin must be inserted into the drive sprocket in order for the machine to be driven by the drive motor.



WARNING: NEVER OPERATE THE MACHINE WITHOUT THE CHAIN GUARD IN PLACE AS SERIOUS INJURY COULD OCCUR.

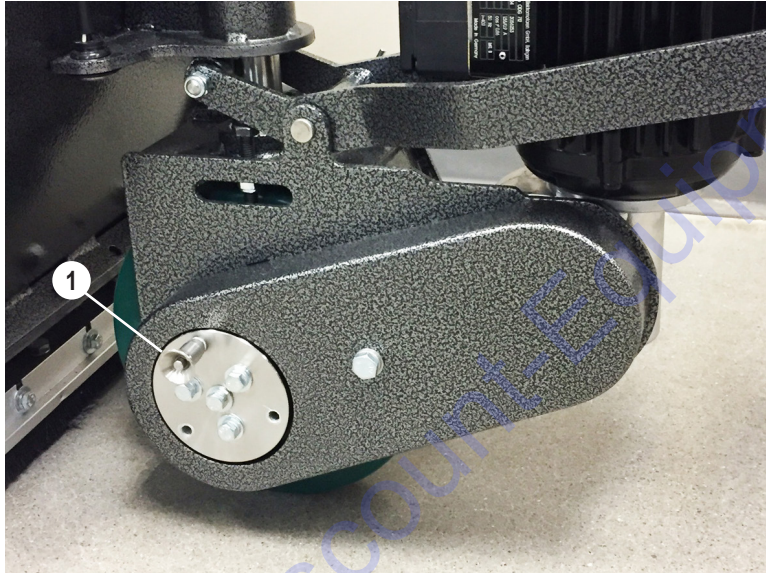

FIG. 8

CORD MANAGER (FIGURE 9)

The cord manager helps prevent the power cord and dust hose from getting in the way of the work path and from getting tangled. It also serves as a strain relief to protect the connection points.



FIG. 9

Components and Assembly

SHOT SELECTION

Selection of shot is important, as this is the material that profiles the surface. As a general rule, use the smallest size shot necessary to achieve the desired profile. Small shot sizes S230 and S280 are used for achieving a CSP (concrete surface profile) of 3. Medium to large shot sizes S330 and S390 are recommended for a CSP from 4 to 6. Travel speed of the machine also plays a major factor in the surface profile. Contact Discount-equipment regarding the best shot to use for your application.

S230 Shot (Approx. Size: .023")

Applications:

- Removing dirt, thin paint coatings and sealers

S280 Shot (Approx. Size: .028")

Often used when the surface is to be sealed afterwards.

Applications:

- Creating fine profiles on surfaces such as concrete and non-glazed tiles
- Removing thin layers of paint

S330 Shot (Approx. Size: .033")

Standard abrasive suitable for about 50-60% of all applications.

Applications:

- Creating a fine to medium texture on concrete
- Removing glazing from tiles prior to sealing with anti-skid coating
- Removing old impregnations and coatings about .04" (1 mm) thick

S390 Shot (Approx. Size: .039")

Creates a medium to aggressive profile on concrete. Fulfills the same purpose as S330 shot when a higher CSP is required.

Applications:

- Removing laitance from new concrete
- Roughening of smooth concrete or natural stone
- Removing thicker coatings
- Cleaning of steel surfaces

Components and Assembly

AIRFLOW (FIGURE 10)

During the operation of the machine the airflow performs the following functions:

- Moves the shot and dust through the machine
- Separates the dust from the shot
- Carries the dust to the dust collector
- Cools the blast wheel, shot and plenum

The following illustration shows the airflow through the machine.

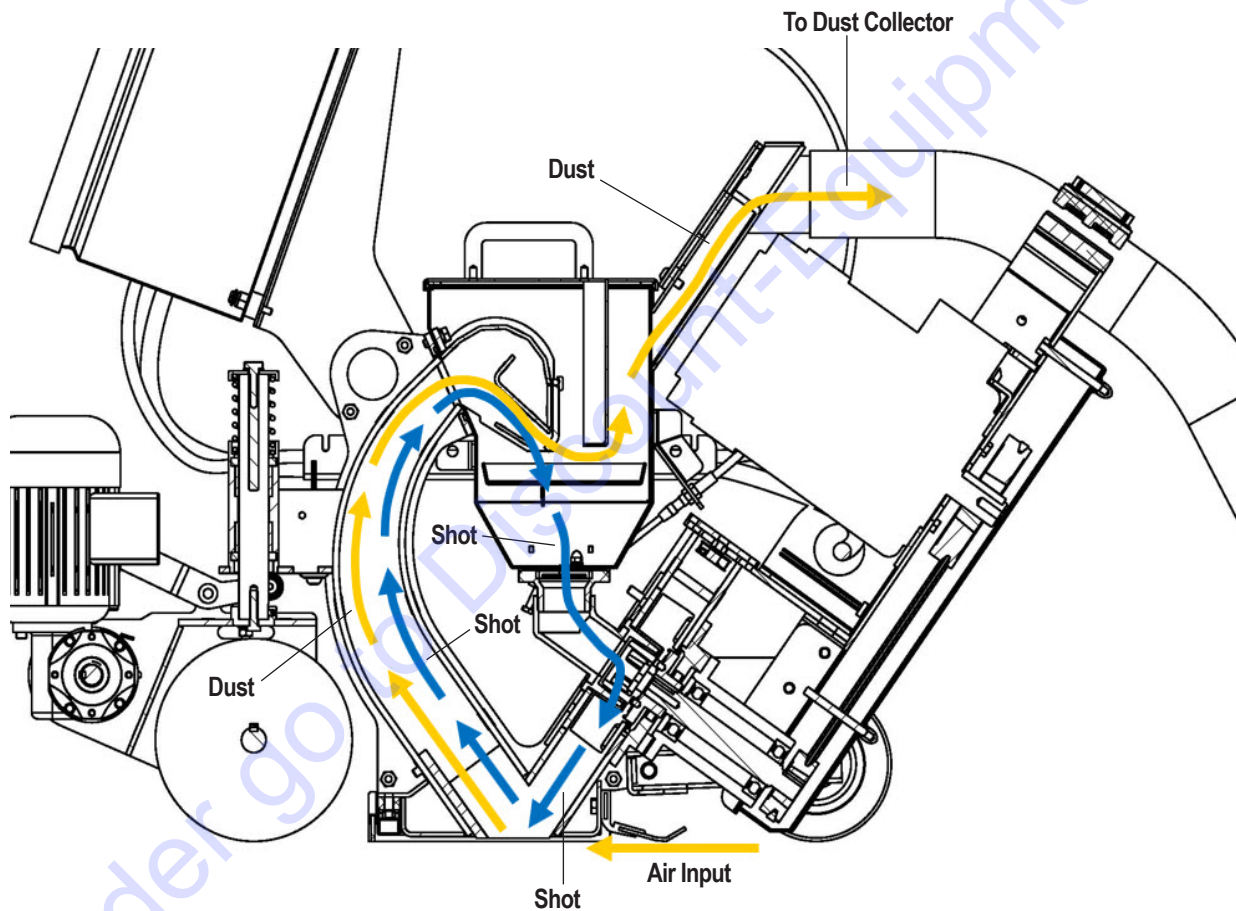

FIG. 10

Components and Assembly

MANUALLY MOVING THE MACHINE (FIGURES 11-12)

To manually move the machine around the jobsite:

1. Remove the quick release pin from the drive sprocket. Insert the pin into the support plate for safe keeping.
2. Use the indicated handle to push or pull the machine. Do NOT use the joystick to push or pull the machine, as this could damage the joystick.
3. When moving the machine over uneven floors, pushing down the handle will raise the blast head to avoid dragging over the uneven surface.

Note: Keep the shot valve closed while moving the machine otherwise shot will drop onto the floor.



CAUTION: WHEN MOVING THE MACHINE MANUALLY, DO NOT USE THE JOYSTICK TO PUSH OR PULL THE MACHINE, AS THIS COULD DAMAGE THE JOYSTICK.

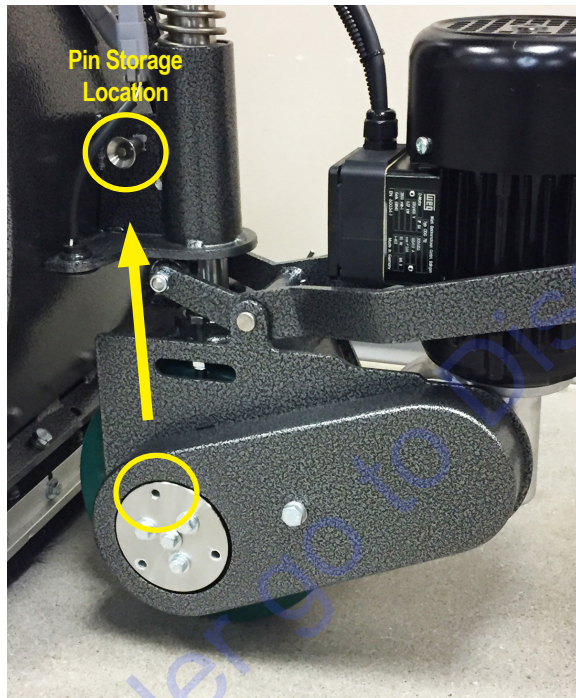

FIG. 11



FIG. 12

Components and Assembly

HOISTING THE MACHINE (FIGURE 13)

When hoisting the machine with a crane or lift, check the total weight permitted. The weight of the machine can be found in the Specifications section or on the serial number plate on the machine. Only use appropriate and qualified hoisting equipment.

Note: Do not fix any ropes or chains to the handle. Fix ropes and chains only at the lifting points shown.



WARNING: THE MACHINE IS VERY HEAVY. WEIGHT OF MACHINE IS SHOWN IN SPECIFICATIONS SECTION OR ON SERIAL NUMBER PLATE. WHEN LIFTING MACHINE, FOLLOW YOUR COMPANY'S SAFETY GUIDELINES TO AVOID INJURY. THE MACHINE MAY ONLY BE LIFTED BY THE LIFTING POINTS SHOWN.



WARNING: WHEN LIFTING MACHINE, PREVENT HANDLE FROM SWINGING TO AVOID INJURY AND DAMAGE TO MACHINE. BEWARE OF PINCH POINTS.

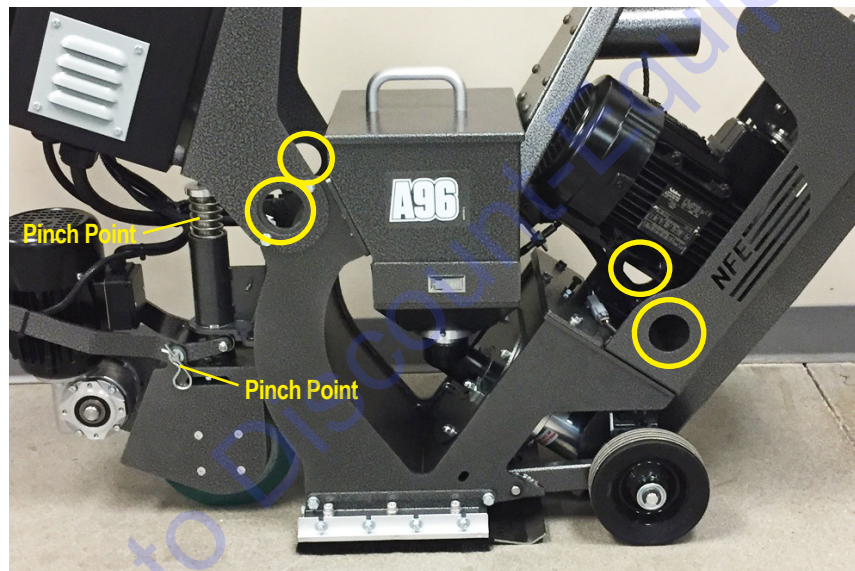

FIG. 13

TRANSPORTING THE MACHINE WITH VEHICLE

When transporting the machine with a vehicle, be careful to avoid damaging the machine. Use straps to secure the machine to the vehicle, routing the straps through the lifting points shown in Figure 13. Make sure all parts of the machine are fixed.



WARNING: BEFORE PERFORMING MAINTENANCE, ALWAYS DISCONNECT THE MACHINE FROM POWER TO PREVENT ACCIDENTAL START-UP.

CLEANING DEBRIS FROM HOPPER (FIGURE 14)



WARNING: USE GLOVES WHEN REMOVING DEBRIS FROM HOPPER. STAPLES, NAILS OR OTHER SHARP OBJECTS THAT MAY HAVE BEEN PICKED UP DURING USE COULD CAUSE INJURY TO BARE HANDS.

1. Remove the lid from the separator.
2. Pull the mesh tray from the separator and empty the debris.
3. Reinsert the tray.
4. Replace the lid.

ADDING SHOT (FIGURE 15)

1. Make sure the shot valve is closed before filling hopper.
2. Remove the lid (1) from the separator.
3. Ensure the wire mesh tray (2) is in place.
4. Fill the hopper with shot up to the bottom of the mesh tray.
5. Replace the lid.

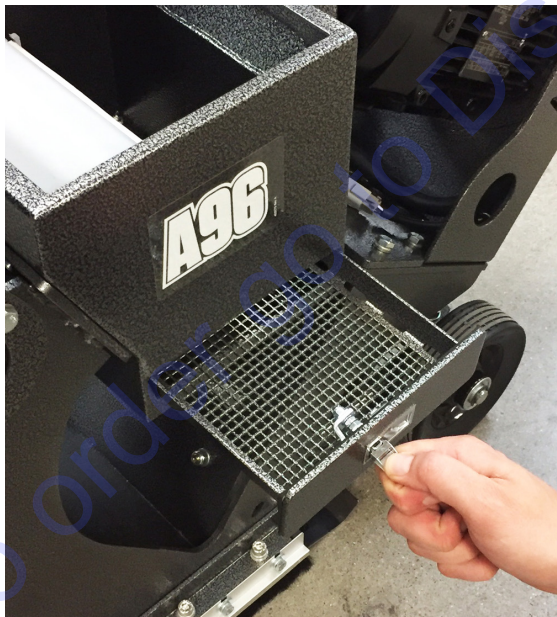

FIG. 14

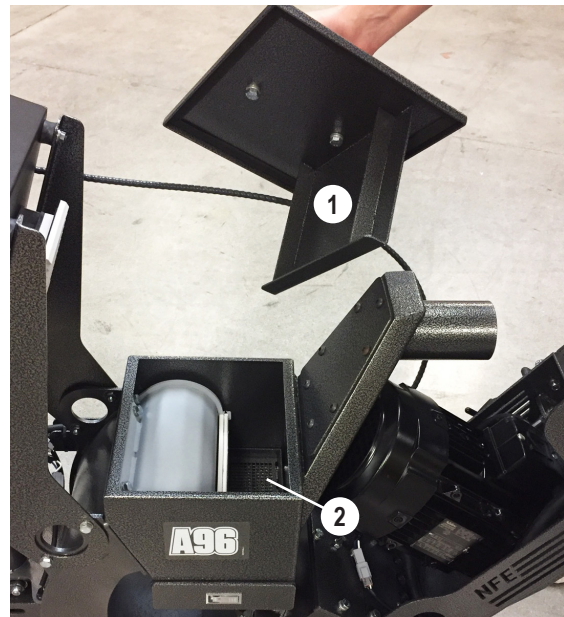

FIG. 15

Operation

SECURING THE POWER CORD AND DUST HOSE (FIGURE 16)

Secure the power cord and dust hose with the cord manager before beginning operation.

Note: Make sure to use the power cord included with the machine.



FIG. 16

VERIFYING THE CORRECT MOTOR DIRECTION (FIGURE 17)

Before operating the machine, verify the direction of the blast wheel motor. The motor must rotate in the direction indicated by the arrow on the fan cover. Motor rotation can be observed through the openings in the fan cover. Reverse rotation will result in poor performance and premature wear. If the direction is wrong, see the Troubleshooting Guide.



FIG. 17

PREPARING FOR OPERATION

Complete the following before startup:

- Ensure all protective covers are attached correctly.
- Check that all parts are assembled correctly.
- Check that all fasteners are tight.
- Check parts for damage and wear; replace if necessary.
- Make sure the hopper is free of debris and that the shot valve functions properly.
- Check the level of shot in the hopper; fill if necessary.
- Secure the power cord and dust hose with the cord manager.
- Verify the correct motor direction.
- It is important to operate the dust collector on a separate circuit from the shot blaster. The shot blaster needs the full amp draw to operate effectively.
- Check that the dust collector is connected correctly and all hose connections are tight.
- Empty dust collector container.
- Check that the magnet height is approximately .13-.38" (3-10 mm) from surface. See Adjusting the Height of Magnets and Brushes section for the adjustment procedure.
- Sweep surface for loose debris prior to operation. Ensure that machine can travel over all high and low spots on the surface; small high and low spots like weld seams or floor joints are not an issue.
- Run magnetic sweep over surface to remove any metallic debris.
- Preload the magnets—Place a small amount of shot on the floor in front of the machine and push the machine back and forth over the shot to create a seal.

Note: Whenever the machine is not used for blasting, the shot valve must be closed.

Operation

STARTUP PROCEDURE

Engaging the Front Wheel Drive (Figure 18)

1. Locate the quick release pin—the pin is stored in the support plate for safe keeping.
2. While pushing the button, insert the quick release pin into any one of the three bores of the drive sprocket.
3. Continue pushing the pin inward while manually moving the machine forward or backward until the pin is fully engaged—the machine is now driven by the front wheel drive motor.



WARNING: BEWARE OF PINCH POINTS.

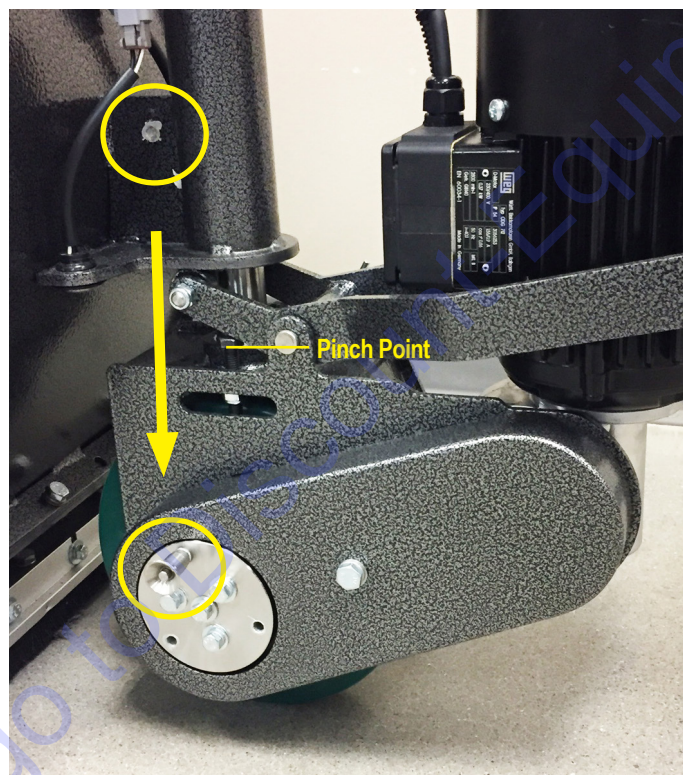

FIG. 18

Starting the Machine (Figure 19)

1. Turn on the dust collector.
2. Check that the shot valve is closed. The shot control lever should be completely pulled back.
3. Ensure the emergency stop switch is released.
4. Turn on the main power switch. The main power indicator will light up.
5. Push the blast wheel START button to start the blast wheel motor and allow the motor to reach a steady state.

A96 230V Machine Only: If the emergency stop switch is released while the main power switch is ON, the blast wheel STOP button must be pushed before the blast motor can be restarted.

6. Adjust the speed using the speed control.
7. Pull the drive trigger to start the front wheel drive and move the machine forward.

Starting the Machine—continued

- Once the machine is moving forward, push the shot control lever forward so the shot valve opens and shot flows to the blast wheel.

Note: The ammeter reading will increase as the shot valve opens. See Specifications section for the maximum amp rating.

- Continue to slowly move the machine forward and watch the blast area carefully. See Figure 19. If necessary, readjust the blast pattern (see Adjusting the Blast Pattern), use the shot valve stop to adjust the maximum opening of the shot valve, or change the travel speed of the machine to achieve the desired profile.

When encountering a raised portion of the floor, the blast head can be raised by pushing down the handle—push down just enough to clear the raised surface.

Note: Pushing down the handle too far will allow shot to spray out the sides of the blast head.



WARNING: WHEN THE BLAST HEAD IS LIFTED FROM THE FLOOR, SHOT COULD SPRAY OUT THE SIDES OF THE BLAST HEAD AT HIGH SPEED.



CAUTION: WHEN BLASTING CONCRETE THE SHOT VALVE MUST ONLY BE OPENED WHEN THE MACHINE IS MOVING FORWARD! IF THE MACHINE IS NOT MOVING WHEN THE VALVE IS OPENED, DEEP GROOVES WILL BE BLASTED INTO THE CONCRETE SURFACE WITHIN SECONDS.



CAUTION: EMPTY THE DUST COLLECTOR REGULARLY.

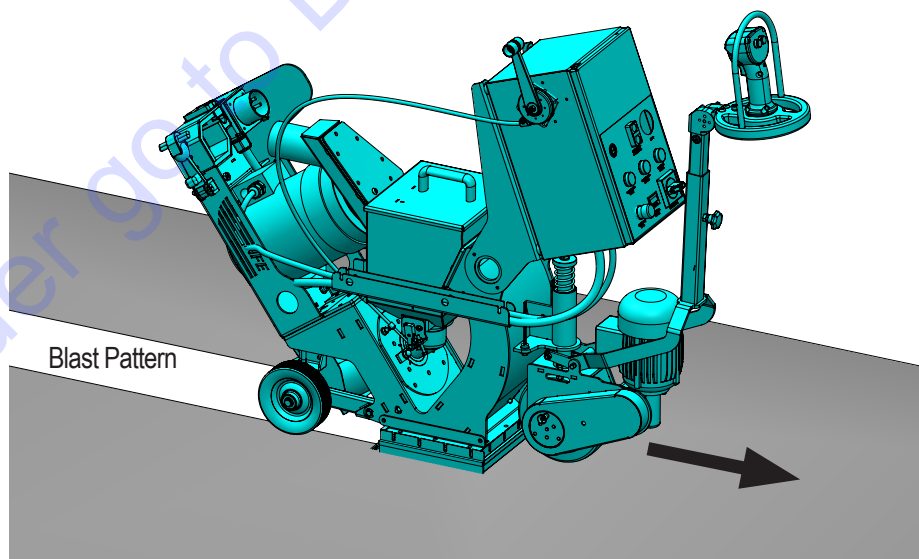

FIG. 19

Operation



WARNING: BEFORE PERFORMING MAINTENANCE, ALWAYS DISCONNECT THE MACHINE FROM POWER TO PREVENT ACCIDENTAL STARTUP.

ADJUSTING THE BLAST PATTERN

Factors That Affect the Blast Pattern

- **Position of the control cage:** The correct adjustment of the control cage is the most important factor in achieving an even blast pattern and optimum machine performance. The position of the control cage determines the direction shot is thrown to the surface and the evenness of the blast pattern. Incorrect adjustment of the control cage results in premature wear and reduced blasting performance.
- **Changing blast wheel and control cage:** After changing the blast wheel and control cage, the blast pattern must be checked and readjusted.
- **Worn blast wheel and control cage:** The blast pattern changes with increased wear of the blast wheel and control cage.
- **Shot size:** The size of shot affects the blast pattern. Check the blast pattern whenever the shot is changed and readjust if needed.

Adjusting the Control Cage (Figures 20-23)

When blasting the surface, material should be removed within the whole width of the blast opening and the blast pattern should be even. Evenness of the blast pattern is determined by the position of the control cage. The control cage grooves indicate the position of the opening through which the shot is fed onto the blast wheel. As a starting point, the control cage grooves should be aligned with the corresponding grooves in the cage support plate as shown in Figure 21. If the machine produces a one-sided, uneven blast pattern, adjust the control cage as follows:

1. Loosen the cage clamps (1). Remove the feed spout (2) for easier adjustment of the control cage.
2. Observe the evenness of the blast pattern to determine the direction of adjustment. View from the front of machine—this is the view from the operator's position facing backwards. Make adjustments in fine increments.
 - If the blast pattern is too heavy to the left, adjust control cage (3) counterclockwise to achieve an even pattern.
 - If the blast pattern is too heavy to the right, adjust control cage (3) clockwise to achieve an even pattern.
3. Tighten the cage clamps. Create a blast pattern to check the adjustment.
4. If blast pattern is even, proceed with blasting. If blast pattern is still uneven, repeat the process.

Note: The control cage must be centered with the blast wheel to reduce wear and avoid grinding shot. If a grinding noise can be heard after the control cage has been adjusted, it must be centered: loosen the cage clamps; move the control cage within the opening to understand the play in the system; center the control cage; tighten the cage clamps; start the machine. Repeat process until the grinding noise can no longer be heard—this may take several attempts. (If the grinding noise is still present, remove the control cage and inspect for wear marks to help determine the adjustment direction.)

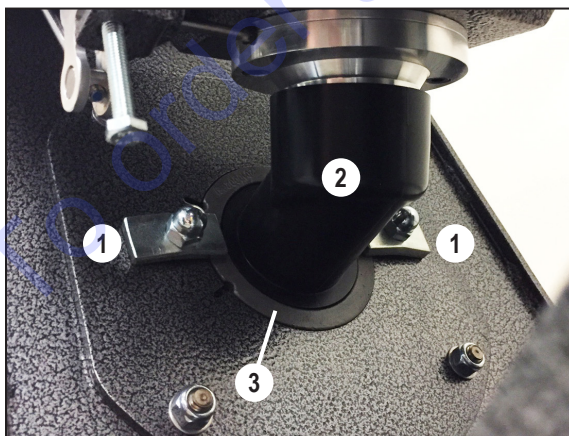

FIG. 20

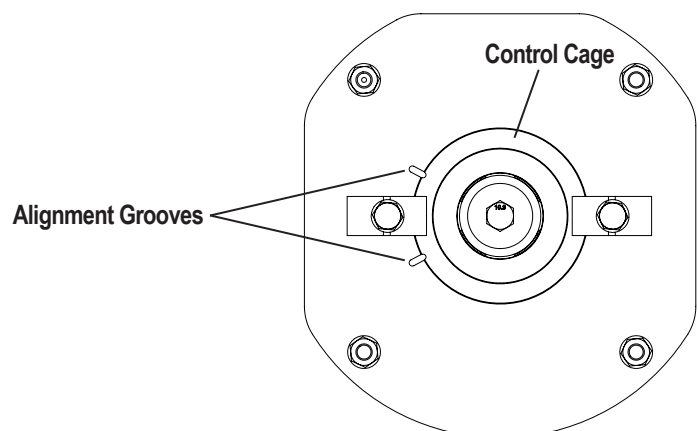

FIG. 21

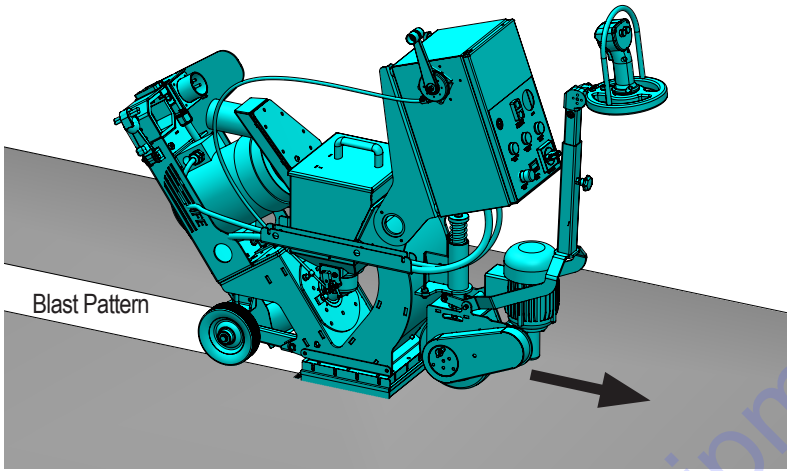

FIG. 22



DIRECTION OF TRAVEL



DIRECTION OF TRAVEL



DIRECTION OF TRAVEL

FIG. 23

Operation

WORKING DIRECTION (FIGURE 24)

1. Carry out blasting in parallel back-and-forth tracks working away from the dust collector. Make sure the power cord and dust hose do not become twisted. Keep an eye on the maximum cord and hose lengths and reposition if needed.
2. When the end of a track is reached, close the shot valve while keeping the blast wheel motor running and turn the machine around.
3. Align the machine for the next track, reopen the shot valve and proceed to blast the new track with minimal overlapping.
4. Repeat this process to complete the surface, moving away from the dust collector to the unblasted surface. When finished, move the dust collector to the completed surface and blast the area where the dust collector was located.

Note: If a fine blasting result is required, it is necessary to blast in the same direction.



CAUTION: TAKE CARE NOT TO TRIP OVER THE POWER CORD AND DUST HOSE.



CAUTION: CLOSE THE SHOT VALVE BEFORE TURNING THE MACHINE AROUND TO MAINTAIN AN EVEN BLAST PATTERN AND AVOID DAMAGING THE FLOOR.

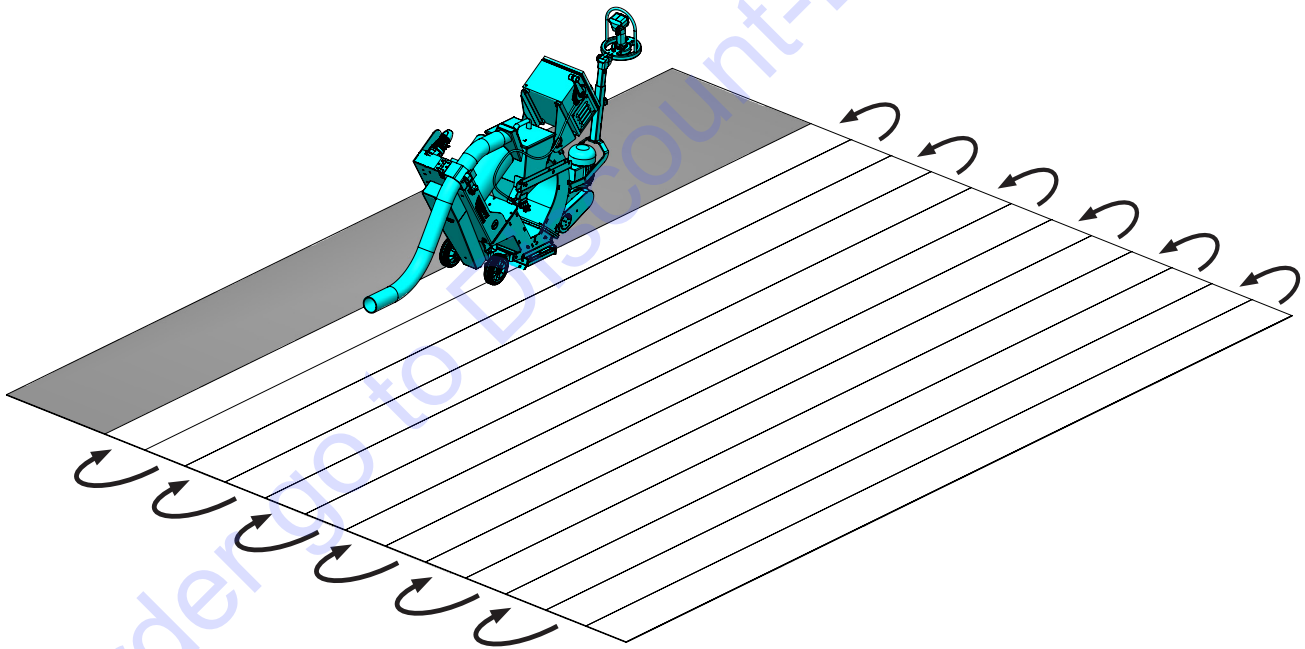

FIG. 24

TRAVEL SPEED

Selecting the right travel speed is important for achieving a good blasting result and depends on the type of surface material and desired profiling. Determine the right travel speed by observing the blasted surface and varying the travel speed during operation.

- Slight profiling on concrete requires a higher travel speed than coarse profiling.
- Blasting on steel requires a very low travel speed.



WARNING: BEFORE PERFORMING MAINTENANCE, ALWAYS DISCONNECT THE MACHINE FROM POWER TO PREVENT ACCIDENTAL STARTUP.

ADJUSTING THE HEIGHT OF MAGNETS AND BRUSHES (FIGURE 25)

The correct height adjustment of the magnets is .13-.38" (3-10 mm) and is important for regulating airflow through the machine and creating a good seal. The magnets should be set at the maximum height of .38" (10 mm) for very rough surfaces. For very smooth surfaces the magnets should be set at the minimum height of .13" (3 mm).

1. Loosen the front and side brushes.
2. Adjust the adjuster bolts on the rear wheels and steering column so the bottom of the magnets are .13-.38" (3-10 mm) above the floor.
3. Tighten the front and side brushes flush with the floor.

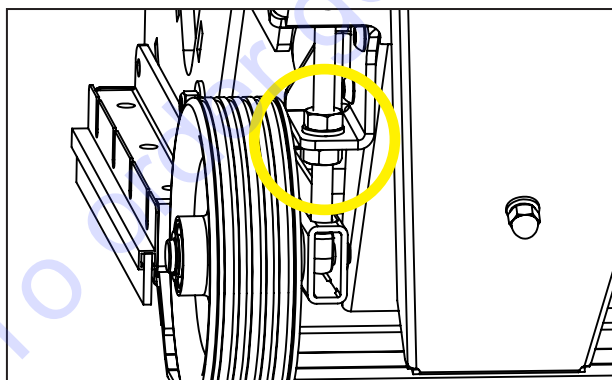
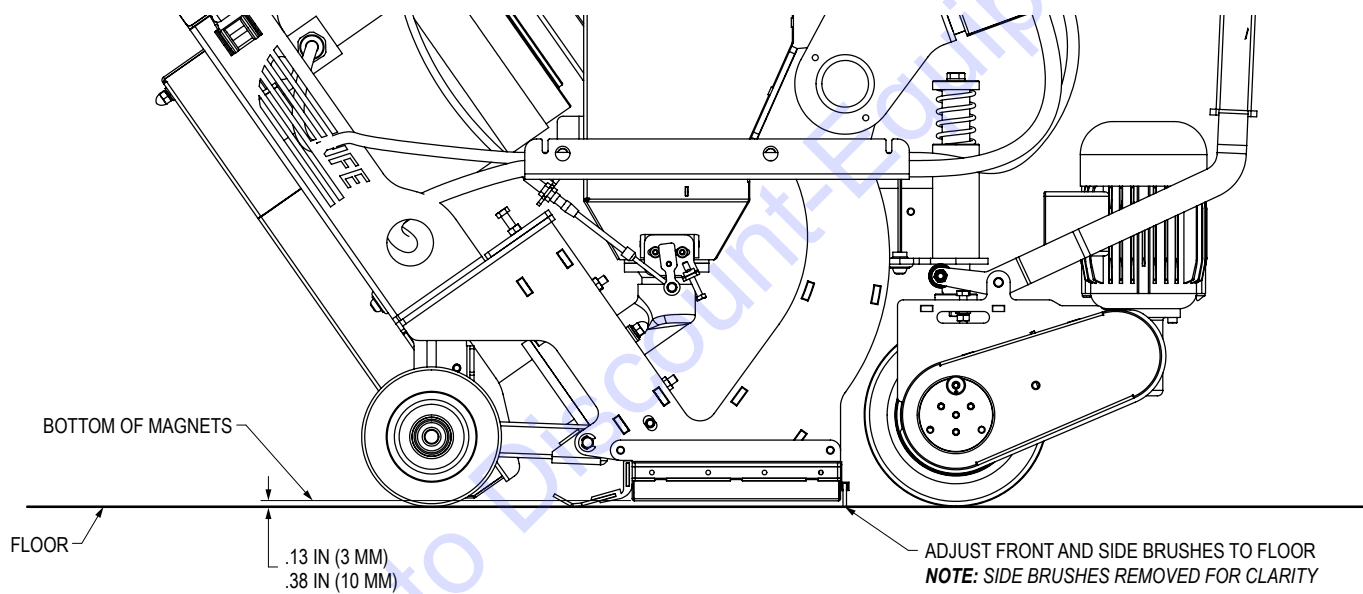

REAR WHEEL ADJUSTER BOLTS

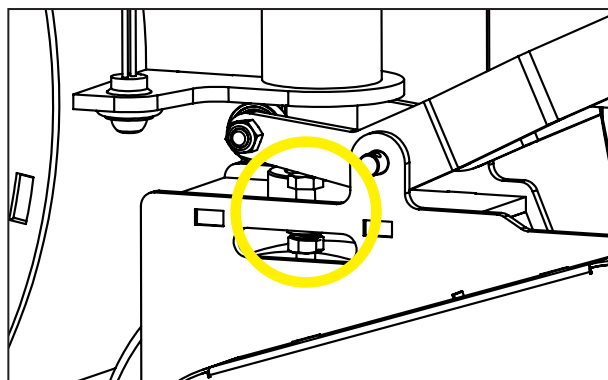

STEERING COLUMN ADJUSTER BOLTS

FIG. 25

Operation

TURNING OFF THE MACHINE

1. Close the shot valve by pulling the shot control lever to the closed position.
2. Keep the machine moving forward until the shot valve is closed to prevent holes from being blasted into the floor.
3. Release the drive trigger to stop the front wheel drive.
4. Push the blast wheel stop button to stop the blast wheel motor.
5. Turn off the main power switch. The main power light will go out.
6. Unplug the machine from the power source.
7. Turn off dust collector.



WARNING: USE A MAGNETIC SWEEP IMMEDIATELY AFTER BLASTING. STEEL SHOT THAT IS LEFT ON THE WALKING SURFACES CREATES A SLIPPING HAZARD WHICH COULD CAUSE UNEXPECTED FALLS.

EMERGENCY STOP (FIGURE 26)

In case of emergency you can immediately stop the machine by pushing the emergency stop switch. To release the emergency stop switch, twist the red button and pull it upwards.

A96 230V Machine Only: If the emergency stop switch is released while the main power switch is ON, the blast wheel STOP button must be pushed before the blast motor can be restarted.



FIG. 26

PREPARING THE MACHINE FOR TRANSPORT OR STORAGE

Before transporting the machine by vehicle or storing the machine for a long period, complete the following:

1. Remove all shot from the machine. It is effective to use the dust collector hose to vacuum out the hopper.
2. Scrape shot from the magnets using a putty knife or similar tool.



WARNING: DO NOT USE YOUR BARE HANDS TO REMOVE SHOT FROM MAGNETS. STAPLES, NAILS OR OTHER SHARP OBJECTS THAT MAY HAVE BEEN PICKED UP DURING USE COULD CAUSE INJURY.

3. Clean the machine.
4. Store the machine in a dry area.
5. Cover the machine.

Troubleshooting Guide



WARNING: BEFORE PERFORMING MAINTENANCE, ALWAYS DISCONNECT THE MACHINE FROM POWER TO PREVENT ACCIDENTAL STARTUP. DO NOT OPEN THE CONTROL BOX OR TOUCH MOTOR WIRING UNTIL THE MACHINE HAS BEEN TURNED OFF, UNPLUGGED AND AT A STANDSTILL FOR APPROXIMATELY FIVE MINUTES TO PREVENT THE POSSIBILITY OF ELECTRIC SHOCK.

GENERAL

| Problem | Cause | Solution |
|-----------------------------|--|---|
| Unusual vibrations or noise | Control cage not centered. | Center control cage. |
| | Blast wheel installed incorrectly. | Check pin on wheel hub. |
| | Loose blast wheel bolt. | Replace and/or tighten bolt. |
| | Wheel hub worn out. | Replace wheel hub. |
| | Unbalance due to broken blast wheel blade. | Replace blast wheel. Check inside of machine and remove broken blade. |
| | Worn motor bearings or shaft. | Replace motor and/or load adaptor. |
| | Uneven wear of blast wheel. | Replace blast wheel. |
| Reduced or no performance | Uneven blast pattern. | Adjust control cage. |
| | Not enough shot in hopper. | Add shot. |
| | Insufficient shot fed to blast wheel. | Clean mesh tray. Check valve for blockage. |
| | Loose shaft clamp. | Tighten set screw to secure clamp to shaft. |
| | Broken belt. | Replace belt. |
| | Valve out of adjustment. | Inspect valve for proper opening and closing. |
| | Too much dust in hopper. | Check dust collector filters and replace if needed. Purge more frequently. Verify CFM rating of dust collector is sufficient. |
| | Blast wheel or control cage is worn out. | Replace worn parts. |
| | Valve does not close properly. | Clear valve of debris. |
| | Too much shot fed when turned on. | Ensure motor reaches a steady state before opening the valve. |
| | Travel speed is too fast. | Reduce travel speed to achieve desired profile. |
| | Blast motor rotating in wrong direction. | See Electrical section. |
| Dropping shot | Too much dust in shot hopper. | Check filters and size of dust collector (CFM). Concrete is too soft, building up too much dust in hopper. |
| | Separator cover is not sealed. | Check cover seal for air leaks. Adjust cover position or replace seal. |
| | Shot hopper is over-filled. | Remove excess shot to level just below the mesh tray. |
| | Magnet height out of adjustment. | Verify the magnet height is not above .38" (10 mm). |
| | Control cage not rotated correctly. | Adjust control cage to achieve even blast pattern. |
| | Blast wheel worn. | Replace blast wheel. |
| | Liners worn. | Replace liners. |
| | Magnets lost field. | Replace magnets. |
| | Blast motor rotating in wrong direction. | See Electrical section. |

Troubleshooting Guide

GENERAL—CONTINUED

| Problem | Cause | Solution |
|-----------------------|---|--|
| Losing shot | Shot being sucked out of vacuum port. | Use a smaller dust collector or reduce suction and flow. |
| Too much dust present | Insufficient air flow towards dust collector. | Verify CFM rating of the dust collector is sufficient. |
| | | Check all seals and dust hoses. |
| | | Check dust collector filters and replace if needed. Purge more frequently. |
| Machine won't move | Quick release pin not inserted. | Insert pin. |
| | Broken chain. | Replace chain. |

ELECTRICAL

| Problem | Cause | Solution |
|--|--|--|
| Blast wheel motor does not start. Blast wheel motor stops during operation. | Emergency stop is depressed. | Release emergency stop button. For 230V machine only, push the blast wheel STOP button. |
| | Motor power cable damaged. | Check cable, replace if needed. |
| | Internal circuit breaker tripped. | Check for blast wheel obstruction. Ensure control box air filters and fan filter are clean. Reset circuit breaker. |
| | Faulty switch or relays. | Contact Discount-equipment for service. |
| | Motor damaged. | Contact Discount-equipment for service. |
| Blast motor rotating in wrong direction. | Improper motor wiring. | Contact Discount-equipment for service. |
| Control box does not power on. | Ground fault related failure. | Ensure ground fault protection device is functioning properly. |
| | Cord unplugged. | Plug in cord. |
| | Branch circuit breaker tripped. | Make sure you are using an appropriately sized circuit for the amperage requirements. |
| | Internal circuit breaker tripped. | Reset breaker. If breaker trips again, contact Discount-equipment. |
| | Internal fuse blown (230V machine only). | Replace fuse. If fuse blows again, contact Discount-equipment. |
| | Faulty switch or relays. | Contact Discount-equipment for service. |
| | Internal electrical fault. | Contact Discount-equipment for service. |
| Front wheel drive motor stops during operation. | Motor power cable damaged. | Check cable, replace if needed. |
| | Variable frequency drive (VFD) fault. | Reset main power switch. If problem persists, contact Discount-equipment. |
| | Speed control damaged. | Replace speed control. |
| | Joystick damaged. | Replace joystick. |
| | Motor damaged. | Contact Discount-equipment for service. |
| Blast motor fault indicator illuminated (230V machine only). | Motor wires damaged. | Replace motor cord. |
| | Variable frequency drive (VFD) overheated. | Ensure control box air filter and fan filter are clean. Reset power. |
| | Motor damaged. | Contact Discount-equipment for service. |

Maintenance Schedule



WARNING: BEFORE PERFORMING MAINTENANCE, ALWAYS DISCONNECT THE MACHINE FROM POWER TO PREVENT ACCIDENTAL STARTUP. DO NOT OPEN THE CONTROL BOX OR TOUCH MOTOR WIRING UNTIL THE MACHINE HAS BEEN TURNED OFF, UNPLUGGED AND AT A STANDSTILL FOR APPROXIMATELY FIVE MINUTES TO PREVENT THE POSSIBILITY OF ELECTRIC SHOCK.

MAINTENANCE AND INSPECTION LIST

| Operating Hours/Time Period | Inspection Points and Maintenance Instructions |
|-------------------------------------|---|
| After repairing | <ul style="list-style-type: none"> Ensure all safety devices are functioning properly. Check that all accessible fasteners are tight. |
| Before, during, and after operation | <ul style="list-style-type: none"> Check for any foreign matter in the hopper, feed spout or the blast wheel. Check the amount of shot in the hopper. Refill if necessary. |
| Daily and prior to starting work | <ul style="list-style-type: none"> Check the hose connection for tightness and fixed seals. Check dust hose and filter for damage. Ensure dust collector has been emptied. Check blast wheel, feed spout, liners, and fasteners for wear and damage. Check the separator parts for wear and damage. Remove foreign parts and dust deposits. Check magnets and brushes for wear. Check the electrical connections for dirt and contaminants. Check the electrical motor for dirt and other contaminants. Verify direction of blast wheel motor is correct. |
| Annually | <ul style="list-style-type: none"> Full overhaul and cleaning of the machine. |

MAINTENANCE INTERVALS

| Inspections Interval | Part | Sign of Wear | Repairing Action |
|----------------------|------------------------------------|--|---|
| 10-20 hours | Brushes | Wear at the lower end | Readjust brushes flush with floor or replace if needed. |
| 30-40 hours | Blast wheel and control cage | Blades of the blast wheel are worn 1/3, deep grooves | Replace blast wheel and control cage. |
| 50 hours | Liners | Liner thickness less than .12" (3 mm) thick | Replace liners. |
| | Control box air filter(s) | Dirty or clogged filter(s) | Clean or replace filter(s). |
| | Fan filter (A96 230V machine only) | Dirty or clogged filter | Replace filter. |
| 100 hours | Deflector in the separator | Significant wear of the deflector or inside components | Replace deflector. |
| | Check belt tension | Tension too loose, slipping belt | Tighten belt. |
| 200 hours | Feed spout | Cracked or worn out feed spout | Replace feed spout. |
| | Clean front wheel drive chain | Dirty chain | Clean chain. |

THIS PAGE INTENTIONALLY LEFT BLANK

To order go to Discount-Equipment.com



WARNING: BEFORE PERFORMING MAINTENANCE, ALWAYS DISCONNECT THE MACHINE FROM POWER TO PREVENT ACCIDENTAL STARTUP.

REMOVING THE BLAST WHEEL (FIGURE 1)

1. Remove the feed spout (1) from the housing.
2. Loosen the control cage clamps (2) and remove the control cage (3).
3. Remove the four nuts (4) of the cage support plate (5) and remove the plate.
4. Prevent the blast wheel (8) from turning. Remove the blast wheel bolt (6) and adapter (7).
5. Remove the blast wheel (8).

REPLACING THE BLAST WHEEL (FIGURE 1)

1. Place the blast wheel (8) through the housing opening and onto the wheel hub (9) aligning it with the pins of the hub. Spin wheel to ensure it is properly seated on the pins and doesn't wobble.
2. Clean the threads of the motor shaft and blast wheel bolt (6) removing any shot.
3. Prevent the blast wheel (8) from turning. Install the blast wheel bolt (6) and adapter (7) and tighten the bolt. Spin the blast wheel to ensure it doesn't wobble.
4. Reattach the front cage support plate (5) with the four nuts (4). Spin blast wheel to ensure it doesn't wobble.
5. Install the control cage (3) aligning the control cage grooves with the corresponding grooves in the cage support plate (5). Spin blast wheel and listen for any grinding noises.
6. Tighten the cage clamps to secure the control cage (3). Make sure the blast wheel can rotate freely.
7. Replace the feed spout (1).
8. Adjust the control cage to achieve an even blast pattern. See Adjusting the Control Cage procedure.

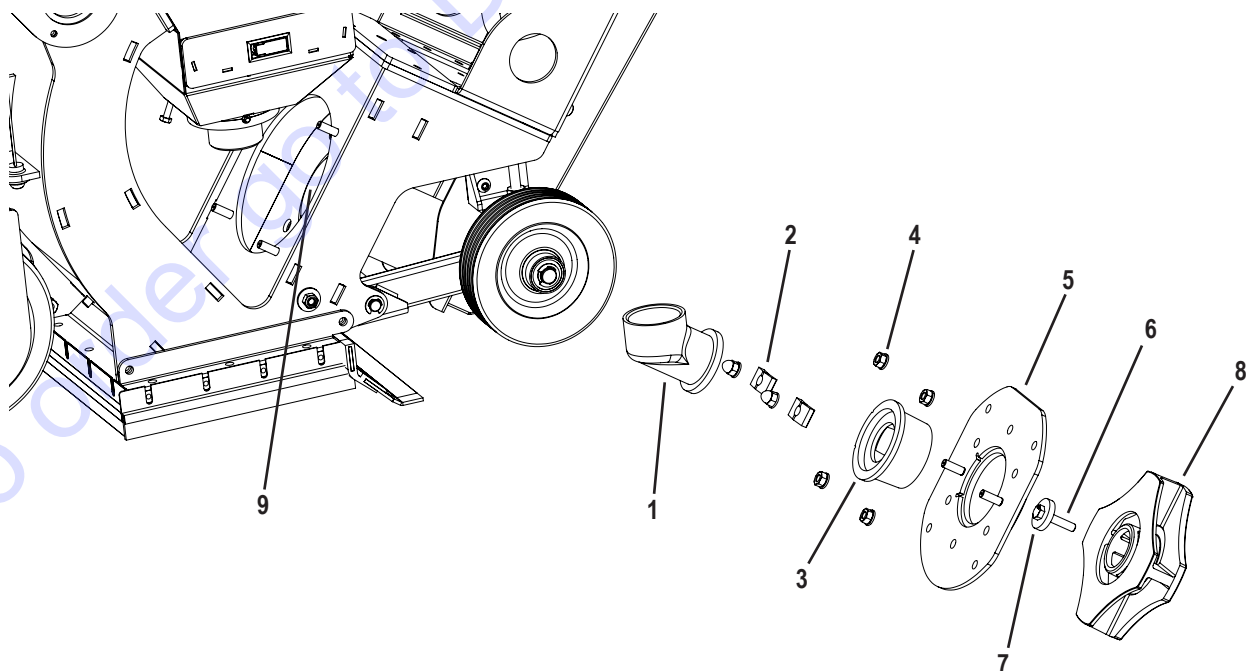

FIG. 1

Maintenance



WARNING: BEFORE PERFORMING MAINTENANCE, ALWAYS DISCONNECT THE MACHINE FROM POWER TO PREVENT ACCIDENTAL STARTUP.



WARNING: THE MACHINE IS VERY HEAVY. WEIGHT OF MACHINE IS SHOWN IN SPECIFICATIONS SECTION OR ON SERIAL NUMBER PLATE. WHEN LIFTING MACHINE, FOLLOW YOUR COMPANY'S SAFETY GUIDELINES TO AVOID INJURY. SEE HOISTING THE MACHINE SECTION IN OPERATING MANUAL.



WARNING: WHEN LAYING THE MACHINE DOWN OR LIFTING UPRIGHT, PREVENT HANDLE FROM SWINGING TO AVOID INJURY AND DAMAGE TO MACHINE. BEWARE OF PINCH POINTS.



WARNING: USE GLOVES WHEN HANDLING THE LINERS AS THE SHARP EDGES COULD CAUSE INJURY TO BARE HANDS.

REMOVING THE LINERS (FIGURE 2)

1. Before removing the liners, remove the blast wheel for easier liner removal and replacement. See Removing the Blast Wheel procedure.
2. Loosen the jam nut and pressure screw (1). Then remove the cover (2) by removing the four screws.
3. Remove the fasteners of the side liners and bottom liner.
4. Lay the machine down on the right side exposing the underside of the machine.
5. Turn the side liners (3 and 4) toward the inside of the blast housing and remove them through the bottom opening of the housing.
6. Remove the bottom liner (5) through the bottom opening.
7. Rotate the top liner (6) around the wheel hub and remove it through the bottom opening.

REPLACING THE LINERS (FIGURE 2)

Note: When replacing the liners, a hammer may be needed.

1. Before installing the new liners, check the wheel housing and its corners for wear.
2. Insert the top liner (6) through the bottom opening and rotate it around the wheel hub into the upper part of the housing.
3. Replace the bottom liner (5) through the bottom opening, pushing the studs through the side of the housing. Hand tighten the nuts.
4. Replace the side liners (3 and 4) through the bottom opening, pushing the studs through the side of the housing. Hand tighten the nuts.
5. Lift the machine upright onto its wheels.
6. Tighten the nuts.

Note: Do not overtighten the nuts, as the threaded studs can be damaged.

7. Replace the cover (2) and reinstall the four screws.
8. Tighten the pressure screw (1) until the edges of the top liner are in contact with the upper edges of the side liners. Lock with jam nut.
9. Replace the blast wheel following the Replacing the Blast Wheel procedure.
10. Adjust the control cage to achieve an even blast pattern. See Adjusting the Control Cage procedure.

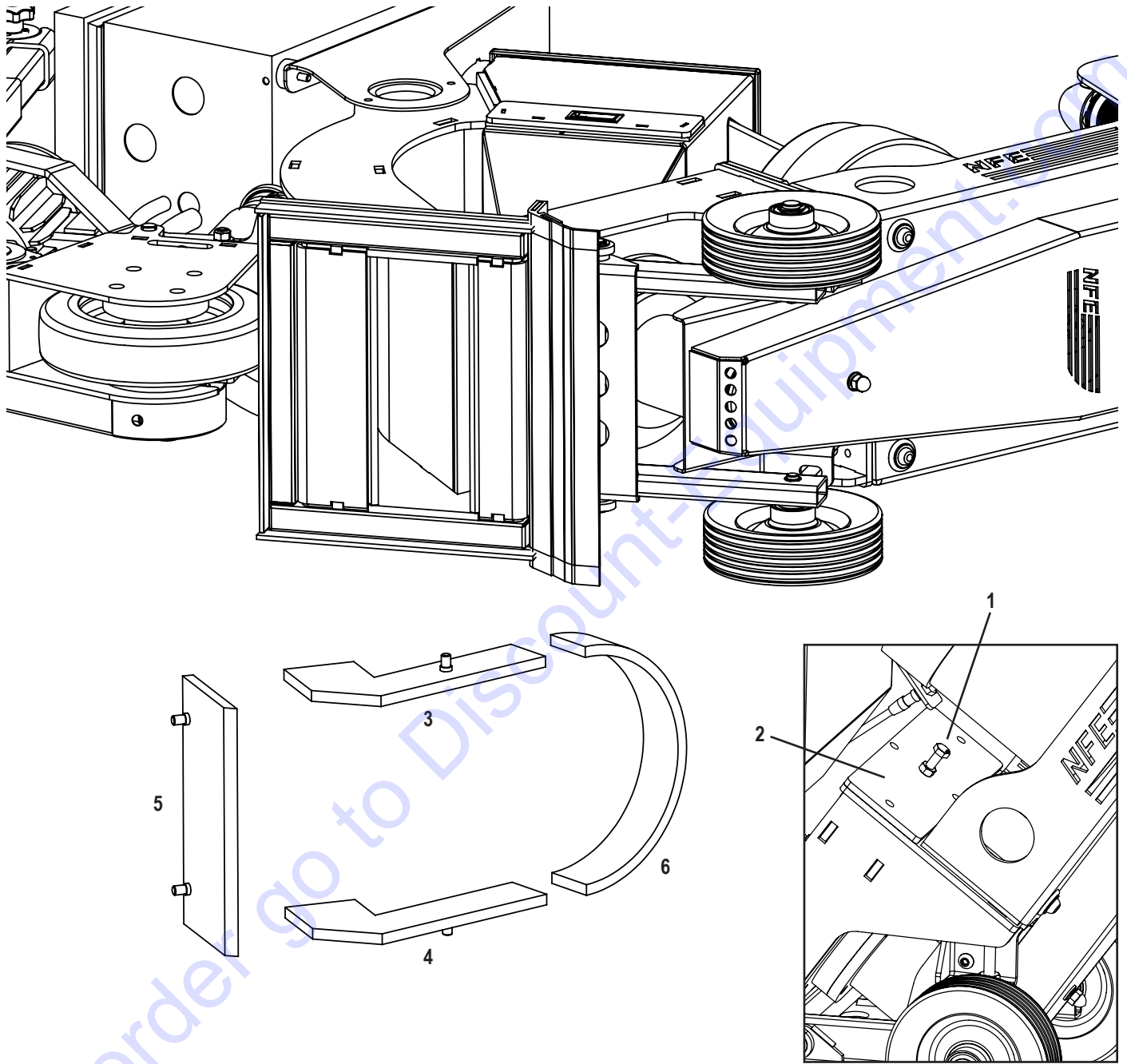

FIG. 2

Maintenance

BELT DRIVE

Key Points

The belt drive transfers power from the blast wheel motor to the blast wheel. The correct belt tension is essential to achieving maximum power transfer and service life. The following points are key to the belt drive running efficiently:

- Too little tension results in slippage, increased belt temperature and shortened belt life.
- Too much tension can result in belt breaks, bearing damage and lower efficiency.
- Temperatures exceeding 158°F (70°C) for a long period of time reduce the service life and performance of the V-belt.
- The grooves of the V-belt pulleys must be free from rust, grease, dirt and damage.
- The use of belt wax or similar substances to increase the friction coefficient is unnecessary and can damage the V-belts. Avoid contamination by oil, grease or chemicals.



WARNING: BEFORE PERFORMING MAINTENANCE, ALWAYS DISCONNECT THE MACHINE FROM POWER TO PREVENT ACCIDENTAL STARTUP.



WARNING: NEVER OPERATE THE MACHINE WITHOUT THE BELT GUARD IN PLACE AS SERIOUS INJURY COULD OCCUR.

Adjusting Belt Tension (Figures 3 and 4)

Check for proper belt tension by measuring the belt deflection in the middle of the belt span. Belt deflection should be .16-.24" (4-6 mm).

To adjust the belt tension:

1. Remove the belt guard.
2. Loosen the four motor mounting bolts. Do not remove.
3. Loosen the jam nuts on the adjustment bolts.
4. Adjust the belt tension by turning the two adjuster bolts in the appropriate direction. Make sure to adjust each bolt the same amount.
5. Retighten the jam nuts on the adjuster bolts.
6. Retighten the motor mounting bolts.
7. Replace the belt guard.

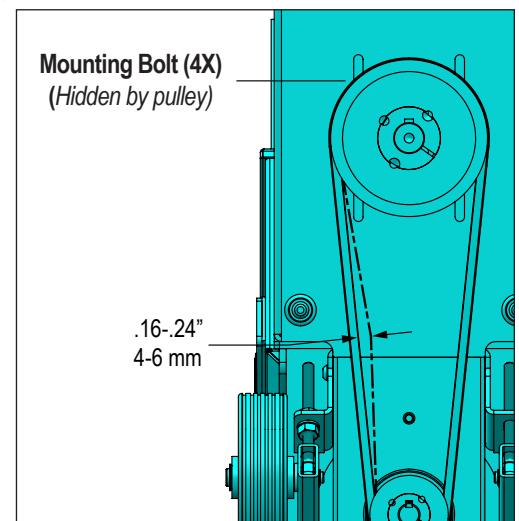

FIG. 3

Removing/Replacing the Belt (Figures 3 and 4)

1. Remove the belt guard.
2. Reduce the distance between the pulleys following the above procedure.
3. Remove the worn belt.
4. Insert the new belt into the pulley grooves. Do not force the belt.
5. Tighten the belt by increasing the distance between the pulleys following the above procedure.
6. Check for proper belt tension.
7. Reinstall the belt guard.

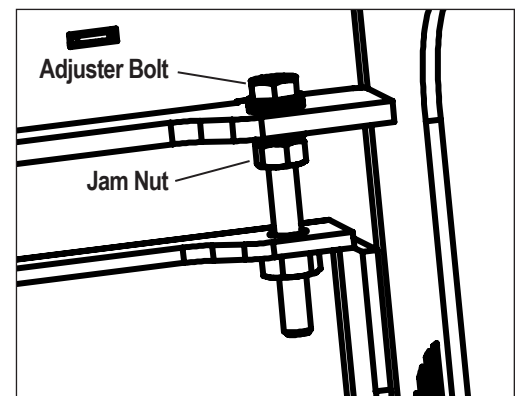

FIG. 4

TO PURCHASE THIS PRODUCT PLEASE CONTACT US



**Equipment Financing and
Extended Warranties Available**



**Discount-Equipment.com is your online resource for
commercial and industrial quality parts and equipment sales.**

561-964-4949

visit us on line @ www.discount-equipment.com

Select an option below to find your Equipment

Search by Manufacturer

Search by Product Type

Request a Quote

We sell worldwide for the brands: Genie, Terex, JLG, MultiQuip, Mikasa, Essick, Whiteman, Mayco, Toro Stone, Diamond Products, Generac Magnum, Airman, Haulotte, Barreto, Power Blanket, Nifty Lift, Atlas Copco, Chicago Pneumatic, Allmand, Miller Curber, Skyjack, Lull, Skytrak, Tsurumi, Husquvarna Target, Stow, Wacker, Sakai, Mi-T-M, Sullair, Basic, Dynapac, MBW, Weber, Bartell, Bennar Newman, Haulotte, Ditch Runner, Menegotti, Morrison, Contec, Buddy, Crown, Edco, Wyco, Bomag, Laymor, EZ Trench, Bil-Jax, F.S. Curtis, Gehl Pavers, Heli, Honda, ICS/PowerGrit, IHI, Partner, Imer, Clipper, MMD, Koshin, Rice, CH&E, General Equipment, Amida, Coleman, NAC, Gradall, Square Shooter, Kent, Stanley, Tamco, Toku, Hatz, Kohler, Robin, Wisconsin, Northrock, Oztec, Toker TK, Rol-Air, APT, Wylie, Ingersoll Rand / Doosan, Innovatech, Con X, Ammann, Mecalac, Makinex, Smith Surface Prep, Small Line, Wanco, Yanmar

Taper-Lock Bushings (Figure 5)

Taper-lock bushings are tapered non-flanged split bushings that utilize set screws to mount the pulleys onto the shafts of the blast wheel motor and bearing unit. The same set screws used for installation are used for removal. A hex key wrench is required for tightening and loosening the set screws.

Removing Pulleys

1. Remove the drive belt.
2. Using the hex key wrench, remove the two set screws from the installation holes (1).
3. Thread a set screw into the removal hole (2), tightening in small increments until the pulley is loosened from the bushing.

Note: Each installation and removal hole is only threaded on one side. Installation holes (1) have the pulley side threaded, the bushing side is not threaded. The removal hole (2) has the bushing side threaded, the pulley side is not threaded.

Replacing Pulleys

1. Clean dirt, oil and other contaminants from all contact surfaces. Do NOT use any lubricants on the contact surfaces!
2. Insert the taper-lock bushing into the pulley, matching the hole pattern.
3. Using the hex key wrench, lightly thread the two set screws into the installation holes (1).
4. Mount the assembly onto the shaft, lining up the shaft key with the keyway in the taper-lock bushing.
5. Make sure the pulleys are aligned.
6. Alternately tighten the set screws to secure the pulley to the bushing.

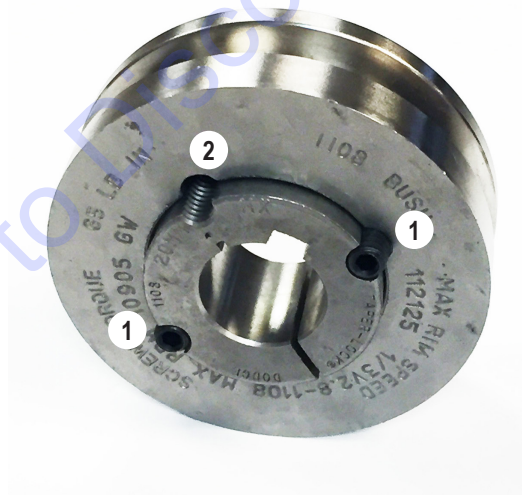

FIG. 5

Maintenance

CHAIN DRIVE

The chain drive transfers power from the front wheel drive motor to the drive sprocket. Proper installation and maintenance of the chain and sprockets contribute to a long service life, while incorrect mounting and insufficient maintenance cause premature wear.



WARNING: BEFORE PERFORMING MAINTENANCE, ALWAYS DISCONNECT THE MACHINE FROM POWER TO PREVENT ACCIDENTAL STARTUP.



WARNING: NEVER OPERATE THE MACHINE WITHOUT THE CHAIN GUARD IN PLACE AS SERIOUS INJURY COULD OCCUR.

Adjusting Chain Tension (Figure 6)

The correct chain tension is set when the chain can be deflected about .39-.59" (10-15 mm) in the middle of the chain sprockets.

Note: Do not adjust chain tension tight otherwise sprocket could be damaged.

To adjust the chain tension:

1. Remove the chain guard.
2. Loosen the four mounting bolts of the front wheel drive motor.
3. Shift the motor in the direction needed to achieve proper tension.
4. Tighten the mounting bolts.
5. Replace the chain guard.

Replacing the Chain (Figure 6-7)

The chain is supplied as a string and must be installed as follows:

1. Degrease the chain to prevent any abrasive particles from adhering.
2. Remove the chain guard.
3. Place the chain string on the chain sprockets.
4. Close the chain using the master link. Install the master link assembly (1), then install the master link plate (2). Install the spring clip (3) by placing it over the grooves in the pins, then using a screwdriver or pliers to push the clip into place. The closed end of the clip should point in the forward direction of the chain.

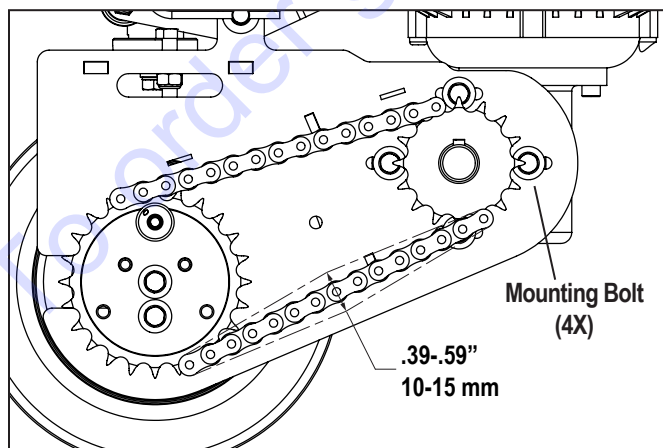

FIG. 6

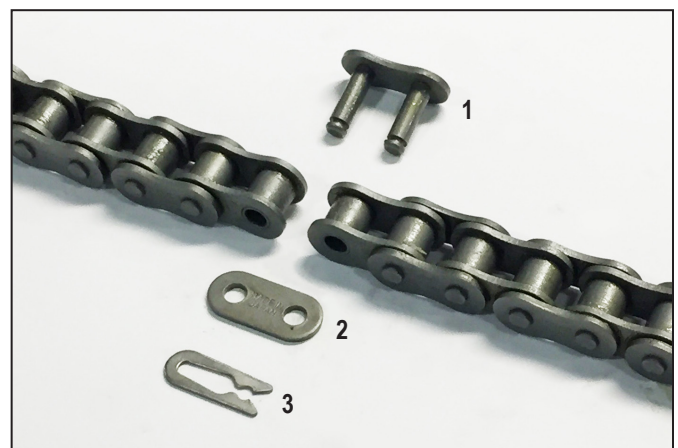

FIG. 7

5. Check for proper chain tension.
6. Replace the chain guard.

Sprocket Alignment

The shafts and chain sprockets must be aligned for optimal drive performance and chain life. If the smaller sprocket is replaced, make sure to install the sprocket completely onto the shaft until it hits the retaining ring. Incorrect mounting causes premature wear of the drive chain.

Chain Drive Maintenance

Always make sure the chain guard is installed before beginning operation. The chain guard protects the drive chain, prevents excessive contamination and prevents injury.

The chain drive needs little maintenance if mounted correctly and not lubricated with grease. The chain drive should be cleaned every three months. Check chain tension at this time.

In order to clean thoroughly:

- Remove the dirt on the outside of the chain drive using a wire brush.
- Wash the chain in petroleum ether or similar.
- Clean the dirt from the internal parts of the chain by putting the chain in petroleum ether, diesel or another solvent for approximately 24 hours. This will soften the dirt in the chain joints and the hardened lubricant remnants. Move the chain several times back and forward in the bath to clean the joints.

FILTER MAINTENANCE (FIGURE 8)



WARNING: BEFORE PERFORMING MAINTENANCE, ALWAYS DISCONNECT THE MACHINE FROM POWER TO PREVENT ACCIDENTAL STARTUP. DO NOT OPEN THE CONTROL BOX OR TOUCH MOTOR WIRING UNTIL THE MACHINE HAS BEEN TURNED OFF, UNPLUGGED AND AT A STANDSTILL FOR APPROXIMATELY FIVE MINUTES TO PREVENT THE POSSIBILITY OF ELECTRIC SHOCK.

Cleaning Control Box Air Filters

The 400V machine has two air filters (one per side); the 230V machine has one air filter on the right side. The air filters are located inside the control box. To check the air filters and clean if necessary, complete the following steps:

1. Use a screwdriver or coin to open the control box door.
2. Remove filters.
3. To clean filters, rinse with water and allow to air dry.
4. Replace filters.

Replacing Fan Filter – 230V Machine Only

The 230V machine has a fan filter located outside the control box. The fan filter is NOT washable and should be replaced with a new filter if clogged. To check the filter and replace if necessary, complete the following steps:

1. Remove the fan louver.
2. Remove the clogged filter.
3. Install the new filter.



A96 230V machine shown

FIG. 8

Maintenance

REPLACING WORK LIGHTS (FIGURE 9)



WARNING: BEFORE PERFORMING MAINTENANCE, ALWAYS DISCONNECT THE MACHINE FROM POWER TO PREVENT ACCIDENTAL STARTUP.

To replace a front or rear work light, complete the following steps:

1. Unplug the connector.
2. Push the LED out of the grommet.
3. Push the grommet out of the hole.
4. Feed the plug through the hole.
5. Reverse the process to install the new light.

| Part# | Description |
|--------|---------------------------------------|
| 404919 | Light, Work, 24VDC, Deutsch Connector |



FIG. 9

REPLACING FUSE – 230V MACHINE ONLY (FIGURE 10)



WARNING: BEFORE PERFORMING MAINTENANCE, ALWAYS DISCONNECT THE MACHINE FROM POWER TO PREVENT ACCIDENTAL STARTUP. DO NOT OPEN THE CONTROL BOX UNTIL THE MACHINE HAS BEEN TURNED OFF, UNPLUGGED AND AT A STANDSTILL FOR APPROXIMATELY FIVE MINUTES TO PREVENT THE POSSIBILITY OF ELECTRIC SHOCK.

The fuse is located inside the control box. To check the fuse, and change if necessary, complete the following steps:

1. Use a screwdriver or coin to open the control box door.
2. Flip open the fuse holder and remove fuse.
3. Use a continuity tester to test the fuse.
4. Install new fuse.

| Position | Part# | Description | Rated Current |
|----------|--------|----------------------------|---------------|
| F1 | 405130 | Fuse, 5x20mm, 2A, Time Lag | 2A |



FIG. 10



WARNING: BEFORE PERFORMING MAINTENANCE, ALWAYS DISCONNECT THE MACHINE FROM POWER TO PREVENT ACCIDENTAL STARTUP. DO NOT OPEN THE CONTROL BOX OR TOUCH MOTOR WIRING UNTIL THE MACHINE HAS BEEN TURNED OFF, UNPLUGGED AND AT A STANDSTILL FOR APPROXIMATELY FIVE MINUTES TO PREVENT THE POSSIBILITY OF ELECTRIC SHOCK.

REMOVING THE SHOT VALVE CONTROL CABLE (FIGURE 11)

1. Remove shot from hopper.
2. Loosen the two adjustment nuts (1) to loosen cable from bracket.
3. Loosen set screw on linkage (2) and slide linkage from shaft.
4. Unscrew swivel (3) from cable (4).
5. Remove shot control lever from side of control box.

REPLACING THE SHOT VALVE CONTROL CABLE (FIGURE 11)

1. Replace shot control lever onto side of control box.
2. With swivel (3) inserted into linkage (2), thread the swivel (3) onto cable (4) until threads protrude from swivel.
3. Slide cable into bracket. Do not tighten the adjustment nuts (1) at this time.
4. Slide linkage (2) onto shaft and tighten set screw on flat of shaft. Linkage should be flush with end of shaft.
5. Pull shot control lever back completely so shot valve is closed.
6. Hand tighten the adjustment nuts (1) making sure that the shot valve flap (5) is horizontal (fully closed position).
7. Move shot control lever back and forth several times verifying the shot valve opens and closes.
8. Tighten the adjustment nuts (1) so the cable is secured to bracket.
9. Set the amperage. See *Setting the Amperage* procedure.

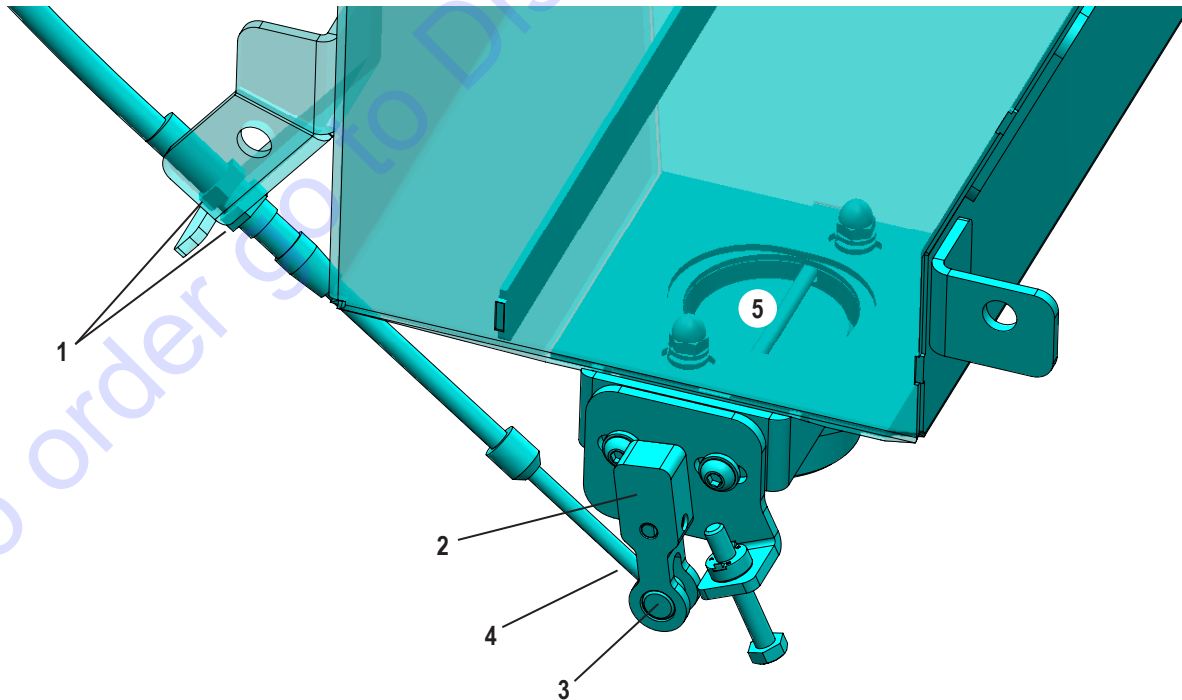

FIG. 11

Maintenance

SETTING THE AMPERAGE (FIGURE 12)

The amperage must be set whenever the shot valve control cable has been damaged or replaced.

1. Move the machine to an area where blasting can be performed.
2. Start the machine following the Preparing for Operation and Startup Procedure sections in the operating manual.
3. Once the blast wheel motor has reached a steady state and the machine is moving forward, slowly push the shot control lever forward while watching the ammeter. The ammeter reading will increase as the shot valve is opened.
4. Continue slowly pushing the lever forward until the ammeter reading matches the Maximum Operating Amps (shown in Specifications section). STOP PUSHING THE LEVER IMMEDIATELY WHEN THE MAXIMUM OPERATING AMPS IS REACHED—DO NOT EXCEED THE MAXIMUM OPERATING AMPS!
5. The shot valve stop must be adjusted to stop the valve at the Maximum Operating Amps. Do NOT adjust at this time.
Note: If the shot valve already stops at the Maximum Operating Amps, then no adjustment is needed.
6. Stop the machine following the Turning Off the Machine procedure in the operating manual.
7. Adjust the shot valve stop. Turning CW decreases amps, CCW increases amps. Adjust in fine increments.
 - If the Maximum Operating Amps is reached before the shot valve stops, turn the stop CW to close the valve slightly.
 - If the shot valve stops before the Maximum Operating Amps is reached, turn the stop CCW to open the valve slightly.
8. Repeat Steps 2-7 until the shot valve stop is adjusted properly—this may take several attempts. The stop is adjusted properly when the shot valve stops at the Maximum Operating Amps.



FIG. 12

RECOMMENDED SPARE PARTS LIST

To avoid downtime, NFE recommends keeping the following spare parts in stock. NFE offers maintenance kits (A96KIT for 230V 60 Hz and A96KIT-400 for 400V 50 Hz) which contain the indicated parts as well as tools needed for some maintenance work.

| Part Number | Description | Quantity | Included In Kit? | |
|-------------|--|----------|------------------------|----------------------------|
| | | | A96KIT (230V 60 Hz) | A96KIT-400 (400V 50 Hz) |
| 404330 | Service Kit, Blast Wheel, 20mm x 165mm, NFE | 1 | Yes | Yes |
| 404400 | Liner, Top, 8 inch | 1 | Yes | Yes |
| 405110 | Liner, Side LH, w Stud, 8 inch | 1 | Yes | Yes |
| 405111 | Liner, Side RH, w Stud, 8 inch | 1 | Yes | Yes |
| 405112 | Liner, Bottom, w Stud, 8 inch | 1 | Yes | Yes |
| 404603 | Assy Brush, Side, 10 inch | 2 | Yes | Yes |
| 404392 | Assy Brush, Front, 8 inch | 1 | Yes | Yes |
| 404870 | Adapter, Blast Wheel | 1 | Yes | Yes |
| 405003 | Bolt, Hex, M8x1.25 x 40mm Long, Class 10.9 | 1 | Yes | Yes |
| 405010 | Belt, V, 3VX Style, 40" (230V 60 Hz only) | 1 | Yes | - |
| 406299 | Belt Poly V, J8 x 1059 (41.5") (400V 50 Hz only) | 1 | - | Yes |
| 404380 | Seal, Hub, Blast Wheel | 1 | No | No |
| 404844 | Assy Cable, Feed Valve, w Lever | 1 | No | No |
| 405295 | Filter, Fan, 92mm (230V 60 Hz only) | 1 | No | - |

Parts List and Diagrams

OVERALL

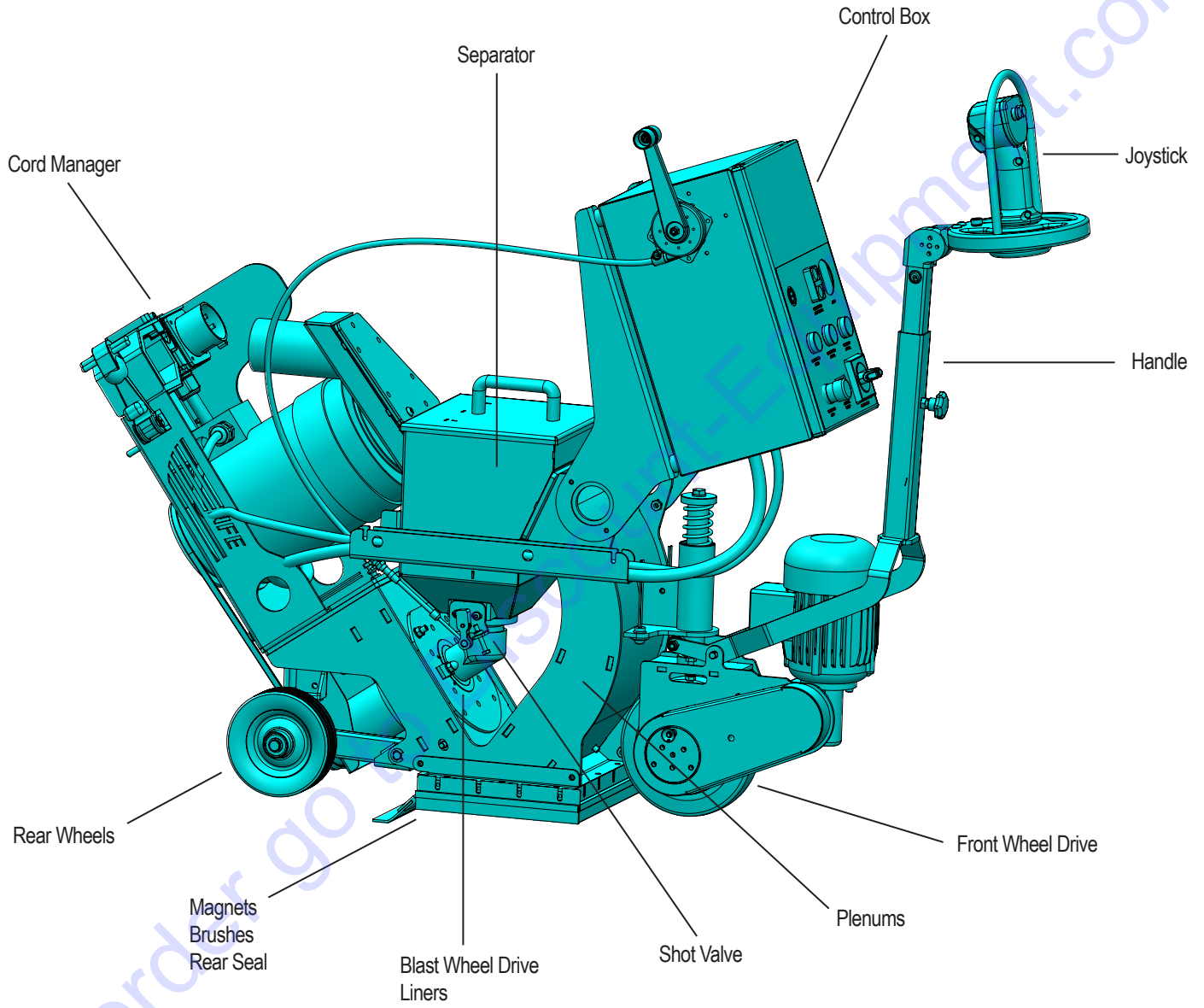

A96 230V machine shown

Parts List and Diagrams

LINERS

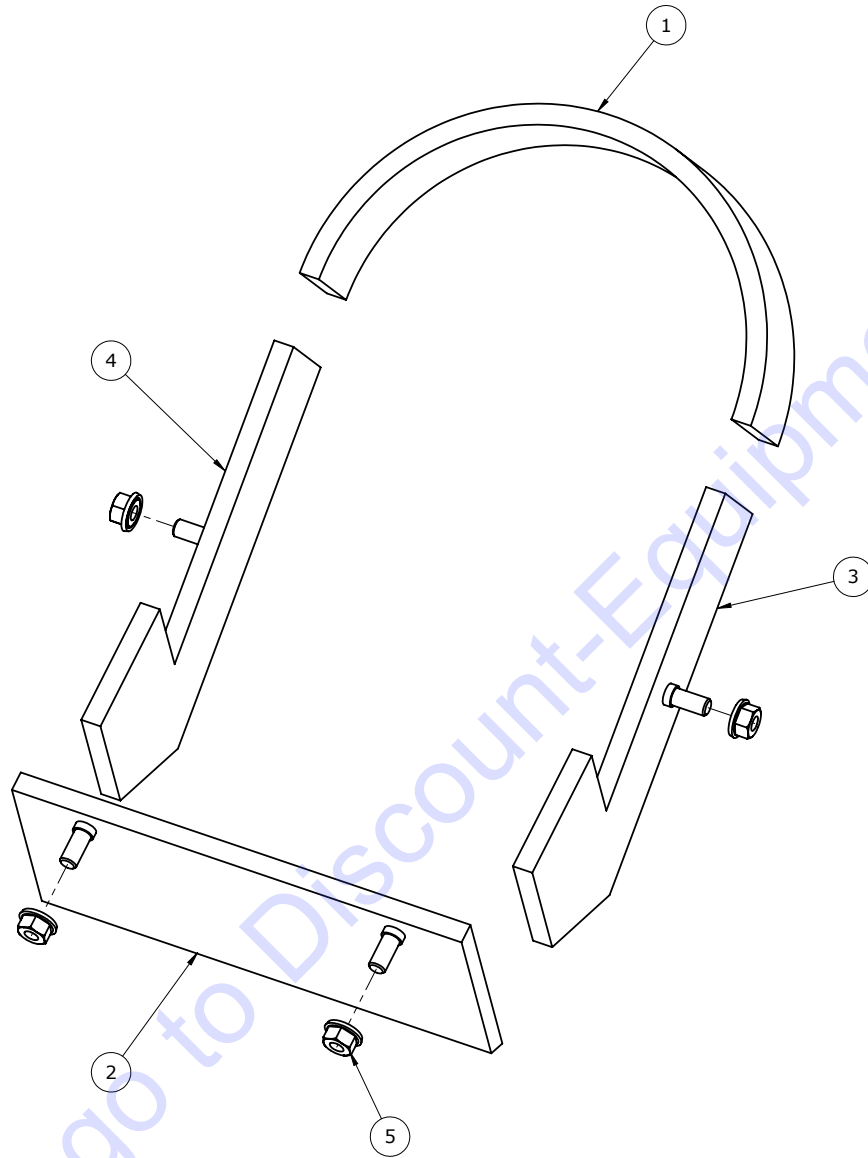

| Item# | Part# | Description | QTY |
|-------|--------|---|-----|
| 1 | 404400 | Liner, Top, 8 Inch | 1 |
| 2 | 405112 | Liner, Bottom, w Studs, 8 Inch | 1 |
| 3 | 405111 | Liner, Side, RH, w Stud, 8 inch | 1 |
| 4 | 405110 | Liner, Side, LH, w Stud, 8 inch | 1 |
| 5 | 405286 | Nut, Hex, w Spring Lock Washer, M8x1.25, Clear Zinc | 4 |

Parts List and Diagrams

BLAST WHEEL DRIVE AND CORD MANAGER

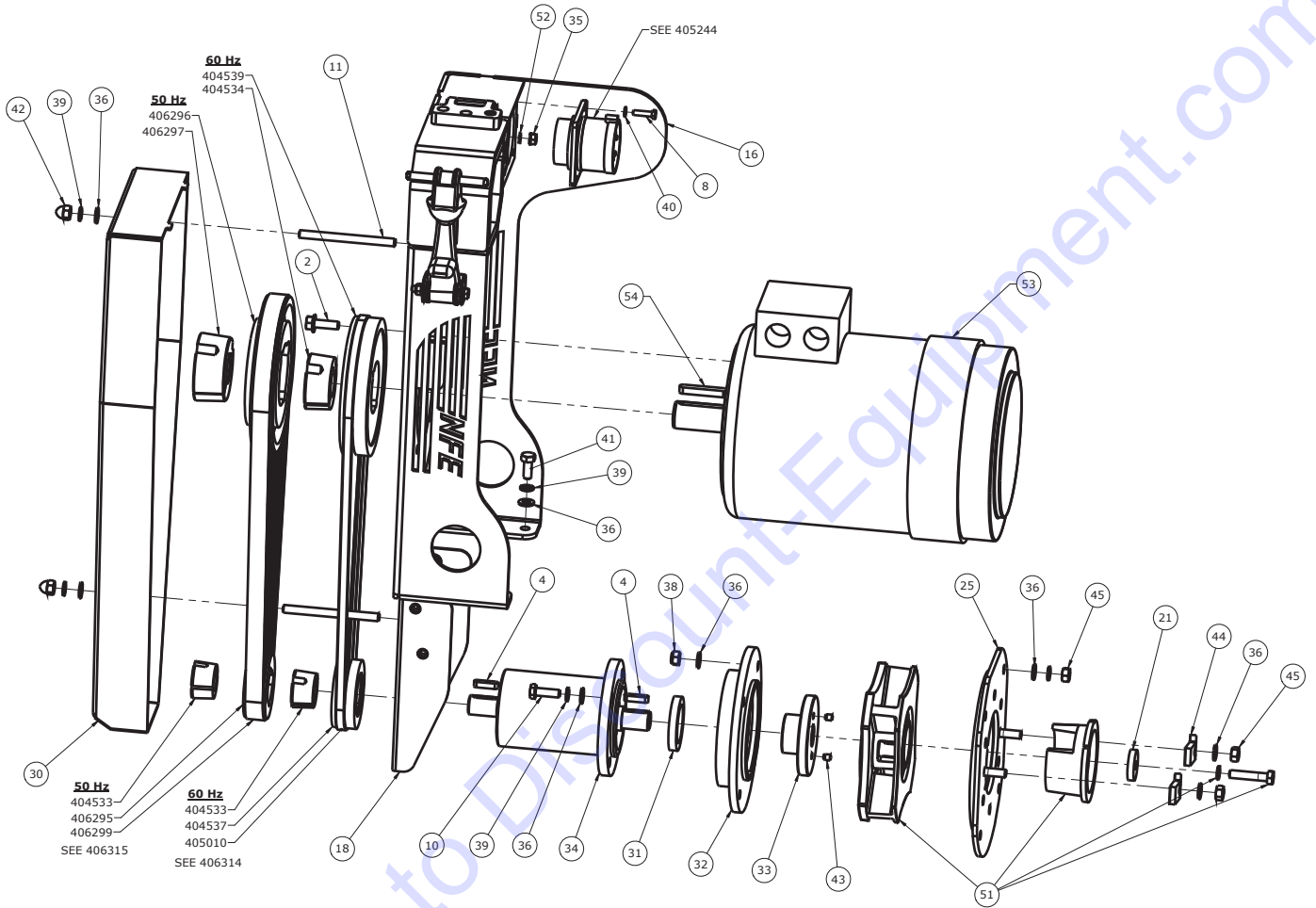

Parts List and Diagrams

BLAST WHEEL DRIVE AND CORD MANAGER (CONT'D)

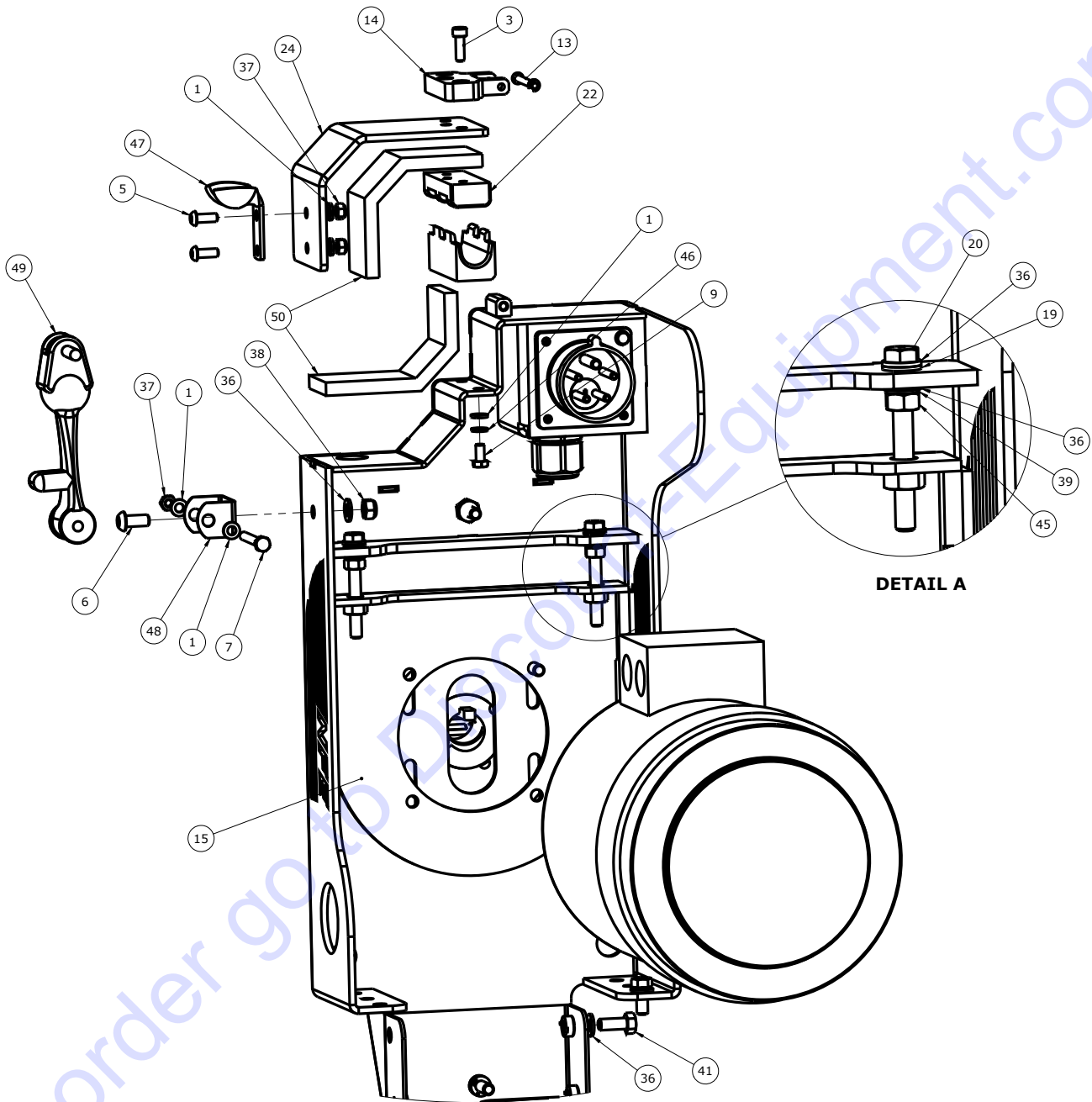

Parts List and Diagrams

BLAST WHEEL DRIVE AND CORD MANAGER (CONT'D)

| Item# | Part# | Description | QTY |
|-------|------------|---|-----|
| 1 | 405486 | Washer, Flat, M6, Clear Zinc | 6 |
| 2 | 405282 | Screw, Hex Flange, M8x1.25 x 25, Clear Zinc | 4 |
| 3 | 405280 | Screw, Socket Head Cap, M6x1.0 x 18, Clear Zinc | 3 |
| 4 | 405263 | Key, Metric, Rounded, 6 W x 6 H x 25 L, Steel | 2 |
| 5 | 405262 | Screw, Button Head Cap, M6x1.0 x 16, Clear Zinc | 2 |
| 6 | 405261 | Screw, Button Head Cap, M8x1.25 x 18, Clear Zinc | 1 |
| 7 | 405260 | Screw, Hex Head Cap, M6x1.0 x55, Partial Thrd, Clear Zinc | 1 |
| 8 | 405259 | Screw, Hex Head Cap, M5-0.8 x 20, Clear Zinc | 4 |
| 9 | 405258 | Screw, Hex Head Cap, M6x1.0 x12, Clear Zinc | 2 |
| 10 | 74638 | Bolt, Hex Head Cap Full Thread Zinc M8-1.25x25mm8.8 | 4 |
| 11 | 405012 | Rod, Threaded, M8-1.25 x 100, Steel, Clear Zinc | 2 |
| 13 | 405008 | Pin, Clevis, 3/16x1-7/8" usable, w Retaining Ring, Clear Zinc | 1 |
| 14 | 405006 | Hinge, Clamp, Dust Tube | 1 |
| 15 | 405005 | Assy Plate, Tensioner, Motor, 8 inch | 1 |
| 16 | 405004-SV | Assy Weldment Brkt, Motor Mount 8 Inch | 1 |
| 18 | 405001-SV | Assy Guard, Lower, Rear Belt, 8 inch | 1 |
| 19 | 404954 | Washer, Thrust 8x16x1.5mm, Oil Embedded | 2 |
| 20 | 404953 | Screw, Hex Head Cap, M8x1.25 x 70, Clear Zinc | 2 |
| 21 | 404870 | Adapter, Blast Wheel | 1 |
| 22 | 404639 | Clamp, Upper, Power Cord | 1 |
| 24 | 404637-SV | Clamp, Dust Tube | 1 |
| 25 | 404619-SV | Assy Weldment Plate, Cage Support | 1 |
| 30 | 404407-SV | Guard, Motor Belt, 8 inch | 1 |
| 31 | 404380 | Seal, Hub, Blast Wheel | 1 |
| 32 | 404379 | Plate, Support, OHLA | 1 |
| 33 | 404378 | Hub, Blast Wheel, 8 inch | 1 |
| 34 | 404373 | Over-Hung Load Adapter, 8 inch | 1 |
| 35 | 403235 | Nut, Keps, M6-1.0, Clear Zinc | 1 |
| 36 | 401803 | Washer, Flat, M8, Clear Zinc | 29 |
| 37 | 401516 | Nut, Hex, Nylon Insert, M6-1.0, Clear Zinc | 3 |
| 38 | 401509 | Nut, Hex, Nylon Insert, M8-1.25, Clear Zinc | 5 |
| 39 | 401332 | Washer, Lock, M8, Clear Zinc | 13 |
| 40 | 401327 | Washer, Flat, M5, Clear Zinc | 4 |
| 41 | 401315 | Screw, Hex Head Cap, M8-1.25 x 20, Clear Zinc | 8 |
| 42 | 401301 | Nut, Acom, M8x1.25, Clear Zinc | 2 |
| 43 | 400579 | Pin, Hub Wheel | 2 |
| 44 | 400536 | Clamp, Control Cage | 2 |
| 45 | 74635 | Nut, Hex, M8-1.25 | 8 |
| 46 | 74619 | Washer, Lock, M6 | 2 |
| 47 | 5200QL-34 | Bracket, Reverse Catch | 1 |
| 48 | 5200QL-32 | Bracket, Hood Lever | 1 |
| 49 | 5200QL-31 | Lever, Hood | 1 |
| 50 | 5200QL-28A | Foam, 3/8 thick x 2 x 6 | 2 |
| 51 | 404330 | Service Kit, NFE Blast Wheel, 20mm x 165mm | 1 |
| 52 | 403917 | Washer, External Tooth, M6, Clear Zinc | 1 |
| 53 | 404404 | Motor, 5.3 HP, 230V, 3 Phase | 1 |
| 54 | 405283 | Key, Rounded, 8 x 7 x 50mm, Steel | 1 |

Parts List and Diagrams

BLAST WHEEL DRIVE AND CORD MANAGER (CONT'D)

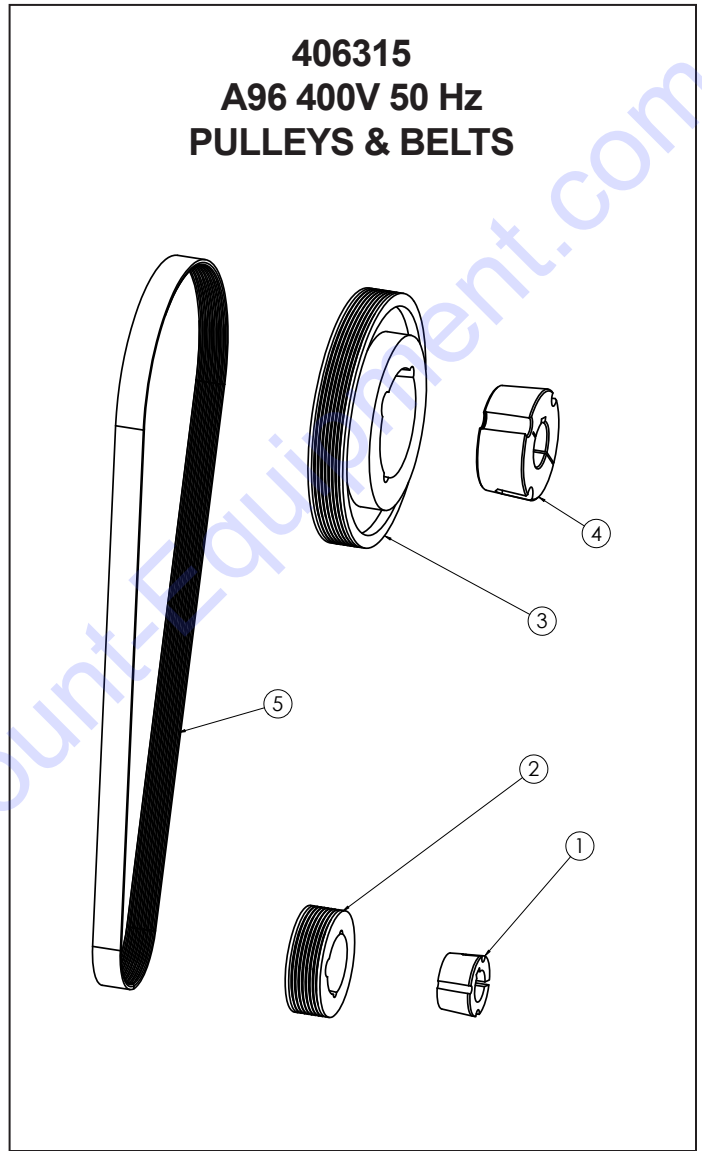
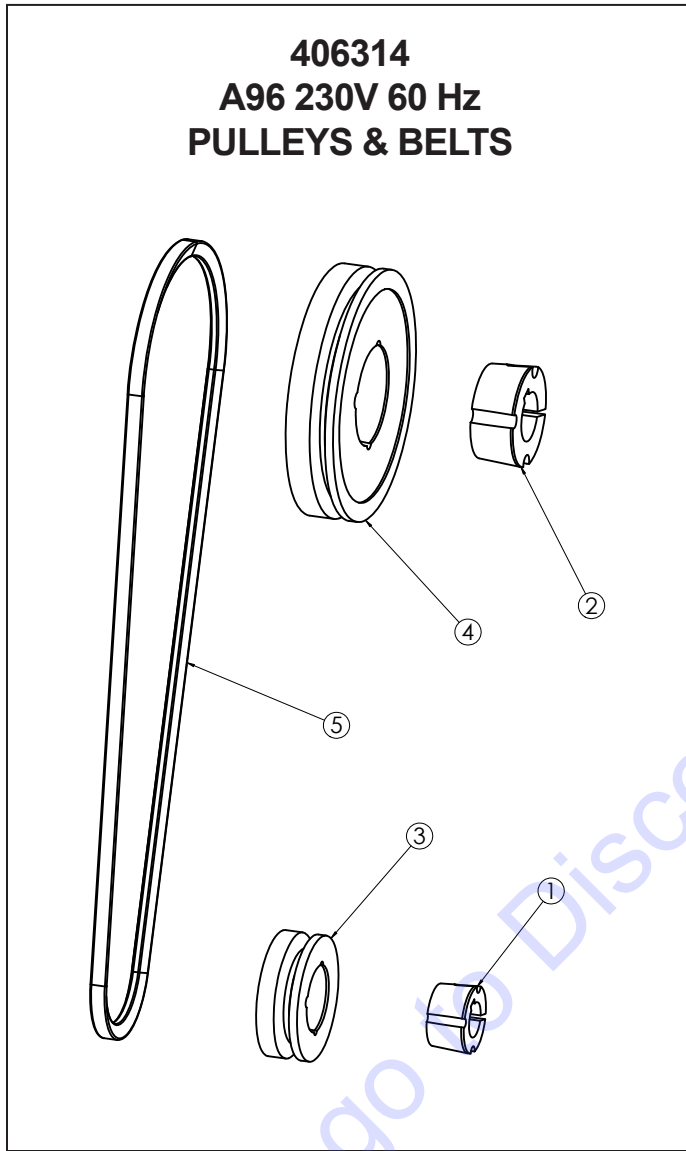

| Item# | Part# | Description | QTY |
|-------|--------|--|-----|
| 1 | 404533 | Bushing, Taper Lock, 1108, 20mm Bore, 6mm Key | 1 |
| 2 | 404534 | Bushing, Taper Lock, 1610, 28 mm Bore, 8mm Key | 1 |
| 3 | 404537 | Pulley, 2.75" PD, Sheave, Single, 3V Style, Taper Lock | 1 |
| 4 | 404539 | Pulley, 5.5" PD, Sheave, Single, 3V Style, Taper Lock | 1 |
| 5 | 405010 | Belt, V, 3VX Style, 40 inch Long | 1 |

| Item# | Part# | Description | QTY |
|-------|--------|--|-----|
| 1 | 404533 | Bushing, Taper Lock, 1108, 20mm Bore, 6mm Key | 1 |
| 2 | 406295 | Pulley, 67 mm Dia, Poly V, J8, 1108 Taper Lock | 1 |
| 3 | 406296 | Pulley, 160 mm Dia, Poly V, J8, 2012 Taper Lock | 1 |
| 4 | 406297 | Bushing, Taper Lock, 2012, 28 mm Bore, 8w x 7h mm Keyway | 1 |
| 5 | 406299 | Belt, Poly V, J8 x 1059 (41.5") | 1 |

Parts List and Diagrams

SEPARATOR AND SHOT VALVE

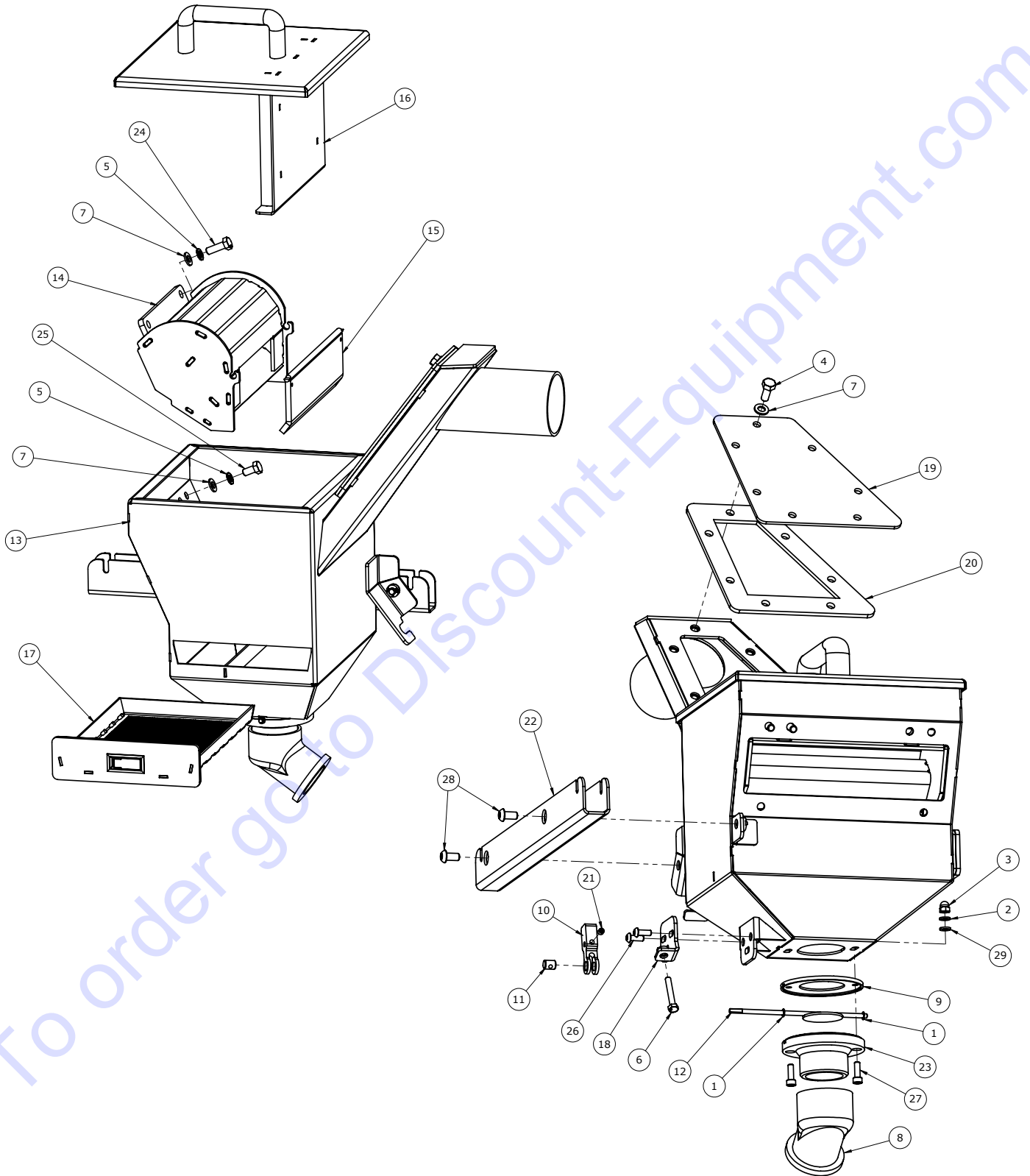

Parts List and Diagrams

SEPARATOR AND SHOT VALVE (CONT'D)

| Item# | Part# | Description | QTY |
|-------|-----------|--|-----|
| 1 | 73910 | E-clip, 3/16 | 2 |
| 2 | 74619 | Washer, Lock, M6 | 2 |
| 3 | 401300 | Nut, Acorn, M6X1 | 2 |
| 4 | 401315 | Screw, Hex Head Cap, M8-1.25 x 20, Clear Zinc | 7 |
| 5 | 401332 | Washer, Lock, M8, Clear Zinc | 6 |
| 6 | 401654 | REPLACE Bolt, Hex Head M6x1.0 x 40mm Long | 1 |
| 7 | 401803 | Washer, Flat, M8, Clear Zinc | 13 |
| 8 | 404423 | Spout, Feed Valve | 1 |
| 9 | 404426 | Plate, Feed Valve | 1 |
| 10 | 404427 | Linkage, Shaft, Feed Valve | 1 |
| 11 | 404430 | Swivel, Feed Valve | 1 |
| 12 | 404431 | Assy Weldment Butterfly, Feed Valve | 1 |
| 13 | 404482-SV | Assy Weldment Hopper, 8 Inch-SV | 1 |
| 14 | 404491 | Assy Weldment Deflector | 1 |
| 15 | 404497 | Assy Weldment Flap, Deflector | 1 |
| 16 | 404510-SV | Assy Lid, Hopper-SV | 1 |
| 17 | 404511-SV | Assy Tray, Hopper-SV | 1 |
| 18 | 404831-SV | Assy Plate, Adjust, Feed Valve-SV | 1 |
| 19 | 404848-SV | Panel, Access, Hopper-SV | 1 |
| 20 | 404849 | Seal, Access Panel, Hopper | 1 |
| 21 | 404850 | Screw, Set, Flat, M6x1.0 x 6mm Long | 1 |
| 22 | 404874-SV | Tray, Electrical Wires-SV | 1 |
| 23 | 405124 | Assy Housing w/Magnet, Feed Valve | 1 |
| 24 | 405254 | Screw, Hex Head Cap, M8x1.25 x 25, Clear Zinc | 2 |
| 25 | 405255 | Screw, Hex Head Cap, M8x1.25 x 16, Clear Zinc | 4 |
| 26 | 405262 | Screw, Button Head Cap, M6x1.0 x 16, Clear Zinc | 2 |
| 27 | 405280 | Screw, Socket Head Cap, M6x1.0 x 18, Clear Zinc | 2 |
| 28 | 405281 | Screw, Button Head Cap, M8x1.25 x 16, Clear Zinc | 2 |
| 29 | 405486 | Washer, Flat, M6, Clear Zinc | 2 |

Parts List and Diagrams

PLENUMS

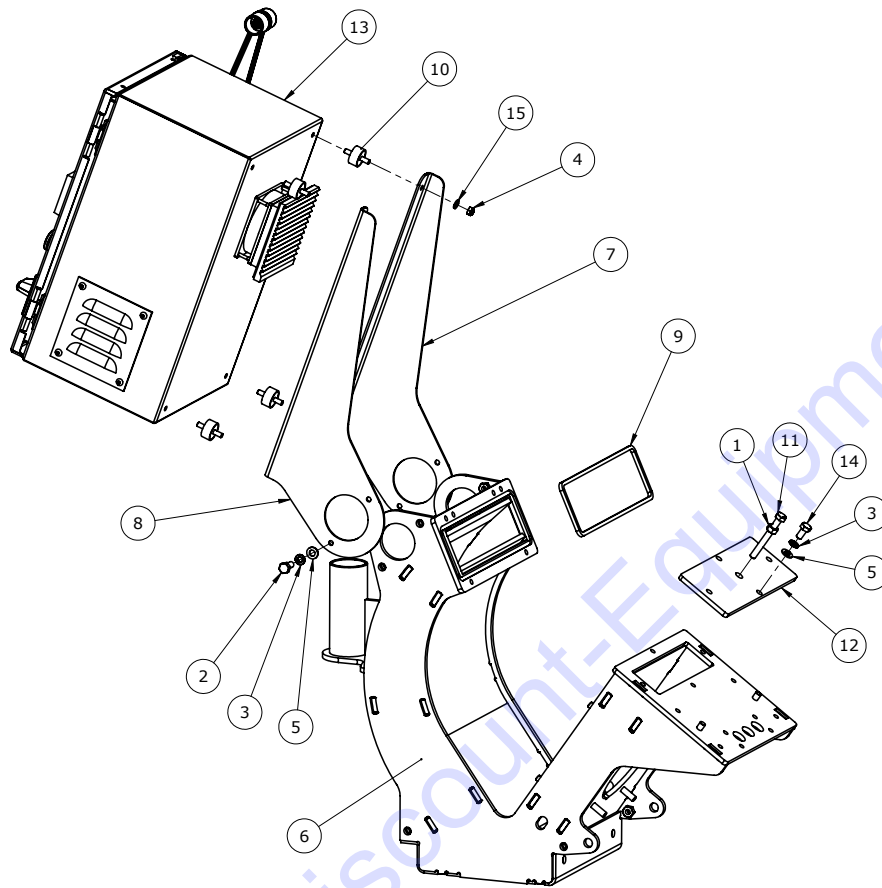

| Item# | Part# | Description | QTY |
|-------|-----------|---|-----|
| 1 | 74635 | Nut, Hex, M8-1.25 | 1 |
| 2 | 401315 | Screw, Hex Head Cap, M8-1.25 x 20, Clear Zinc | 4 |
| 3 | 401332 | Washer, Lock, M8, Clear Zinc | 8 |
| 4 | 401516 | Nut, Hex, Nylon Insert, M6-1.0, Clear Zinc | 4 |
| 5 | 401803 | Washer, Flat, M8, Clear Zinc | 8 |
| 6 | 404350-SV | Assy Rebound Plenum Weldment, 8 inch-SV | 1 |
| 7 | 404626-SV | Mount, LH, Elec Enc, 8 inch-SV | 1 |
| 8 | 404627-SV | Mount RH, Elec Encl, 8 inch-SV | 1 |
| 9 | 404880 | Seal, Hopper-Return Plenum | 1 |
| 10 | 404893 | Mount, Vibration, M6x1, 1 Dia x 500 Long | 4 |
| 11 | 404953 | Screw, Hex Head Cap, M8x1.25 x 70, Clear Zinc | 1 |
| 12 | 405030-SV | Assy Retainer, Top Liner, 8 inch-SV | 1 |
| 13 | 405063 | Assembly, Control Box, 230V, A96 | 1 |
| | 405770 | Assembly, Control Box, 400V, A96 | |
| 14 | 405255 | Screw, Hex Head Cap, M8x1.25 x 16, Clear Zinc | 4 |
| 15 | 405486 | Washer, Flat, M6, Clear Zinc | 4 |

Parts List and Diagrams

REAR WHEELS

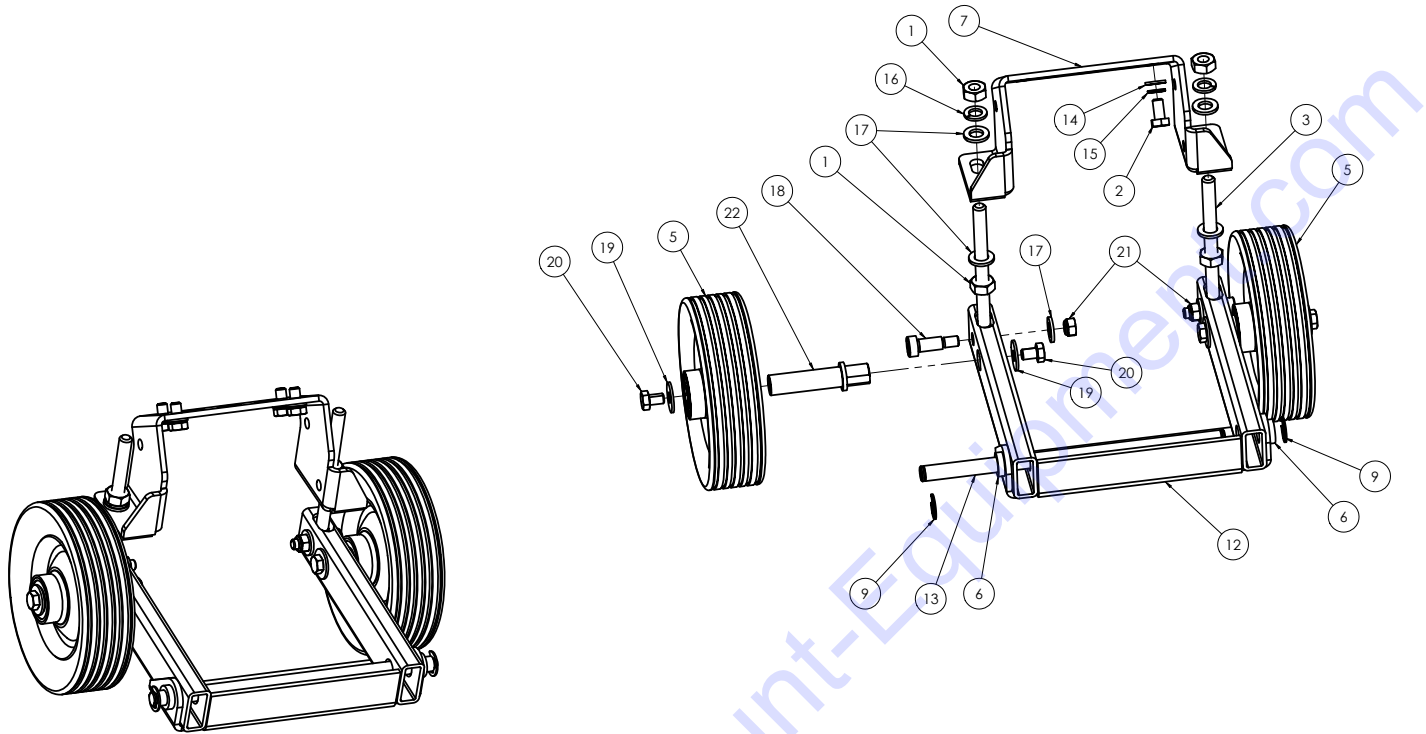

| Item# | Part# | Description | QTY |
|-------|-----------|--|-----|
| 1 | 405266 | Nut, Hex, M10x1.5, Clear Zinc | 4 |
| 2 | 405255 | Screw, Hex Head Cap, M8x1.25 x 16, Clear Zinc | 4 |
| 3 | 405129 | Rod End, 10 x 125mm, Steel | 2 |
| 5 | 405120 | Wheel, 6 in Dia x 5/8 Bore x 2.25 Hub, Ball Bearing, Black | 2 |
| 6 | 405002 | Spacer, Round, 12 x 19 x 5mm, Aluminum | 2 |
| 7 | 404977-SV | Mount, Height Adj, Rear, 8 inch | 1 |
| 9 | 404842 | Ring, Retaining, External, E-Clip, 12mm, Phosphate | 2 |
| 12 | 404360-SV | Assy Weldment Bracket, Rear Wheels, 8 inch | 1 |
| 13 | 404357 | Shaft, Pivot, Rear, 8 Inch | 1 |
| 14 | 401803 | Washer, Flat, M8, Clear Zinc | 4 |
| 15 | 401332 | Washer, Lock, M8, Clear Zinc | 4 |
| 16 | 74657 | Washer, Lock, M10 | 2 |
| 17 | 74655 | Washer, Flat, M10 | 6 |
| 18 | 406554 | Bolt, Shoulder, 10 x 20 x M8-1.25, Alloy Steel | 2 |
| 19 | 401349 | Washer, Fender, M8, Clear Zinc | 4 |
| 20 | 400041 | Screw, Hex Head Cap, M8-1.25 x 12, Clear Zinc | 4 |
| 21 | 401509 | Nut, Hex, Nylon Insert, M8-1.25, Clear Zinc | 2 |
| 22 | 406553 | Shaft, Rear Wheels, Keyed, .625" Dia Nom | 2 |

Parts List and Diagrams

MAGNETS, BRUSHES AND REAR SEAL

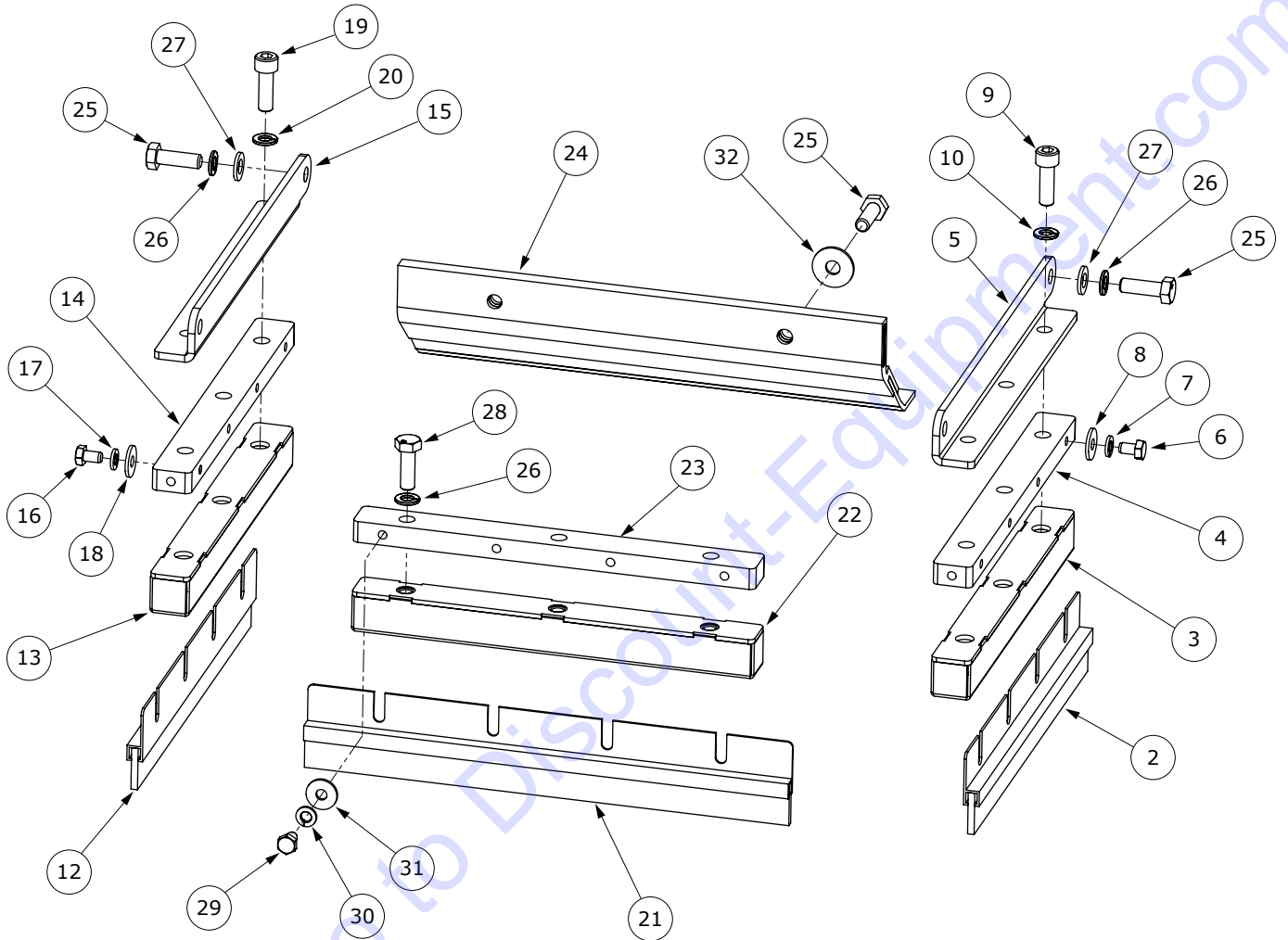

Parts List and Diagrams

MAGNETS, BRUSHES AND REAR SEAL (CONT'D)

| Item# | Part# | Description | QTY |
|-------|--------|---|-----|
| 1* | 404461 | Assy Magnet, Removable RH, 10 inch | 1 |
| 2 | 404603 | Assy Brush, Side, 10 inch | 1 |
| 3 | 404449 | Assy Magnet, Side, 10 inch | 1 |
| 4 | 404457 | Mount, Side Magnet, 10 inch | 1 |
| 5 | 404460 | Bracket RH, Removable Magnet, 10 inch | 1 |
| 6 | 405277 | Screw, Hex Head Cap, M6x1.0 x 16, Stainless Steel | 4 |
| 7 | 405279 | Washer, Lock, M6, Stainless Steel | 4 |
| 8 | 405278 | Washer, Flat, Fender, M6, Stainless Steel | 4 |
| 9 | 405276 | Screw, Socket Head Cap, M8x1.25 x 25, Stainless Steel | 3 |
| 10 | 401332 | Washer, Lock, M8, Clear Zinc | 3 |
| 11* | 404852 | Assy Magnet, Removable LH, 10 inch | 1 |
| 12 | 404603 | Assy Brush, Side, 10 inch | 1 |
| 13 | 404449 | Assy Magnet, Side, 10 inch | 1 |
| 14 | 404457 | Mount, Side Magnet, 10 inch | 1 |
| 15 | 404851 | Bracket, LH, Removable Magnet, 10 inch | 1 |
| 16 | 405277 | Screw, Hex Head Cap, M6x1.0 x 16, Stainless Steel | 4 |
| 17 | 405279 | Washer, Lock, M6, Stainless Steel | 4 |
| 18 | 405278 | Washer, Flat, Fender, M6, Stainless Steel | 4 |
| 19 | 405276 | Screw, Socket Head Cap, M8x1.25 x 25, Stainless Steel | 3 |
| 20 | 401332 | Washer, Lock, M8, Clear Zinc | 3 |
| 21 | 404392 | Assy Brush, Front, 8 Inch | 1 |
| 22 | 404385 | Assy Magnet Front, 8 Inch | 1 |
| 23 | 404399 | Mount, Front Magnet, 8 inch | 1 |
| 24 | 404395 | Flap, Rear Seal, 8 Inch | 1 |
| 25 | 405254 | Screw, Hex Head Cap, M8x1.25 x 25, Clear Zinc | 6 |
| 26 | 401332 | Washer, Lock, M8, Clear Zinc | 7 |
| 27 | 401803 | Washer, Flat, M8, Clear Zinc | 4 |
| 28 | 405274 | Screw, Hex Head Cap, M8x1.25 x 25, Stainless Steel | 3 |
| 29 | 405277 | Screw, Hex Head Cap, M6x1.0 x 16, Stainless Steel | 4 |
| 30 | 405279 | Washer, Lock, M6, Stainless Steel | 4 |
| 31 | 405278 | Washer, Flat, Fender, M6, Stainless Steel | 4 |
| 32 | 401349 | Washer, Fender, M8, Clear Zinc | 2 |

*Item 1 includes Items 2-10. Item 11 includes Items 12-20.

Parts List and Diagrams

HANDLE AND JOYSTICK

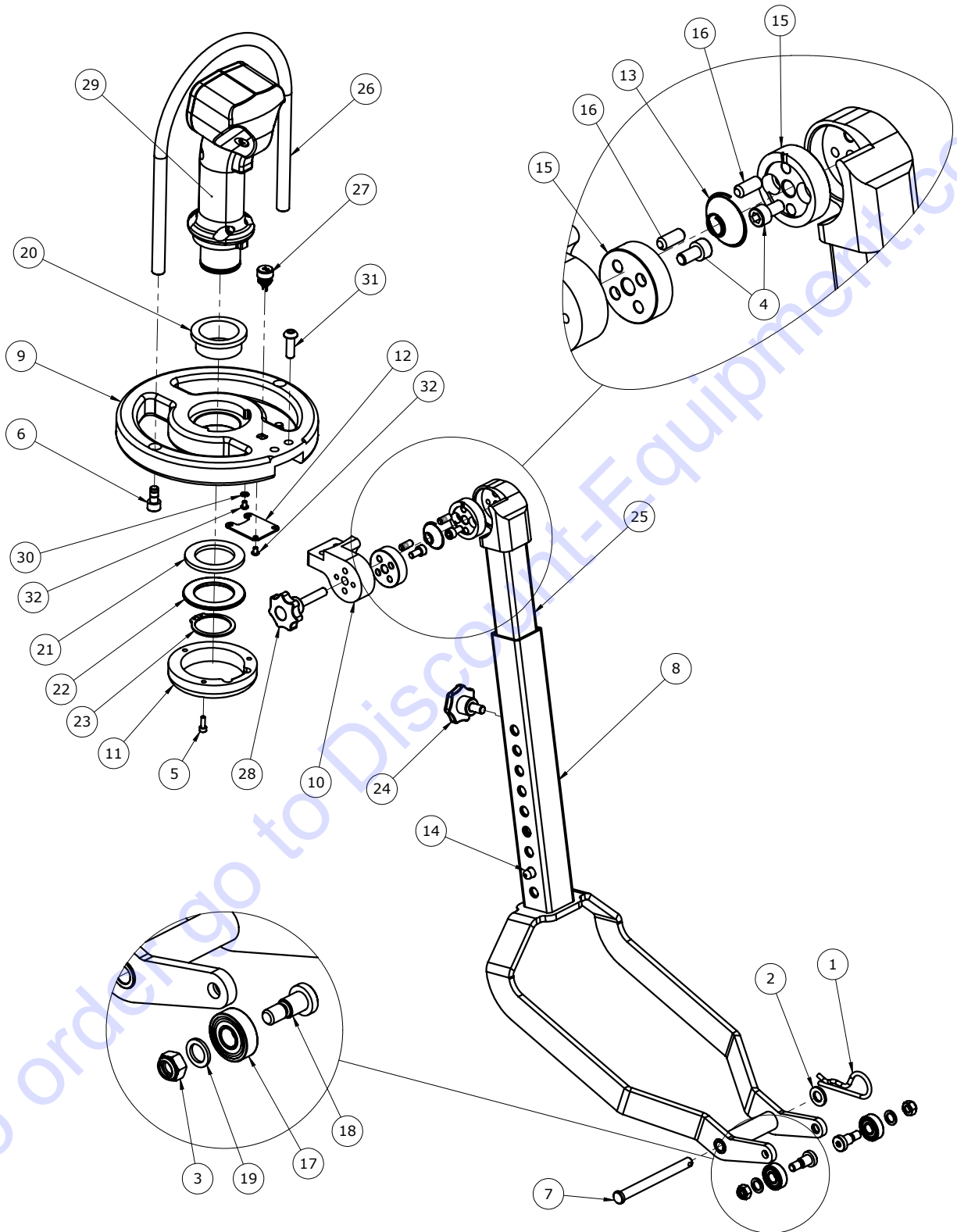

Parts List and Diagrams

HANDLE AND JOYSTICK (CONT'D)

| Item# | Part# | Description | QTY |
|-------|-----------|--|-----|
| 1 | 73536 | 5/8 Hitch Pin Clip | 1 |
| 2 | 74655 | Washer, Flat, M10 | 1 |
| 3 | 401509 | Nut, Hex, Nylon Insert, M8-1.25, Clear Zinc | 2 |
| 4 | 401652 | Screw, Socket Head Cap, M6-1.0 x 12mm | 4 |
| 5 | 401653 | Screw, Socket Head Cap, M4-0.7 x 12 | 3 |
| 6 | 403384 | Screw, Socket Head Cap, M8x1.25 - 16mm, Adhesive Patch | 2 |
| 7 | 404369 | Pin, Clevis, 3/8 Dia x 3.75 Long | 1 |
| 8 | 404513-SV | Assy Weldment Handle, Main-SV | 1 |
| 9 | 404521 | Brace, Joystick, Upper Handle | 1 |
| 10 | 404522 | Mount, Pivot, Joystick Brace | 1 |
| 11 | 404882 | Cover, Joystick Wires | 1 |
| 12 | 404886 | Cap, Joystick, Upper Handle | 1 |
| 13 | 404958 | Spring, Compression, Conical, .43/1.14" OD x .39 x .034, Stainless Steel | 1 |
| 14 | 404968 | Button, Push, Height Adjust, Ø.365x.500 | 1 |
| 15 | 404969 | Plate, Serrated, Locking, 40mm OD x 11.5 Thck | 2 |
| 16 | 404970 | Pin, Spring, 6x16mm, Steel | 4 |
| 17 | 404971 | Bearing, Ball, 10x26x8mm, 6000-2RSH | 2 |
| 18 | 404972 | Bolt, Shoulder, Low Profile, 10x12mm, M8x1.25, Stainless Steel | 2 |
| 19 | 404974 | Washer, Shim, 10 x 15m x .062", Stainless Steel | 2 |
| 20 | 405032 | Bearing, Flange, 40 x 46 x 20mm, Bronze | 1 |
| 21 | 405033 | Washer, Thrust 40x60x4mm, Oil Embedded | 1 |
| 22 | 405034 | Spacer, Round, Joystick | 1 |
| 23 | 405035 | Ring, Retaining, External, Axial, 40mm, Phosphate | 1 |
| 24 | 405039 | Knob, 7 Lobe w stud, M8x1.25 x 15mm long | 1 |
| 25 | 405040 | Assy Weldment Handle, Upper Handle | 1 |
| 26 | 405041 | Guard, Joystick, Upper Handle | 1 |
| 27 | 405088 | Potentiometer, 10K, 20%, 300° Turn | 1 |
| 28 | 405115 | Knob, Plastic, M8 x 40 mm Long Stud | 1 |
| 29 | 405158 | Assy, Joystick, Wired | 1 |
| 30 | 405206 | Washer, External Tooth, M4, Clear Zinc | 1 |
| 31 | 405272 | Screw, Button Head Cap, M8x1.25 x 25, Clear Zinc | 2 |
| 32 | 405273 | Screw, Button Head Cap, M4x0.7 x 6, Clear Zinc | 5 |
| 33* | 404966 | Strain Relief, 90°, Black Nylon, .5" Mount, .25" ID | 1 |

*Not shown

Parts List and Diagrams

FRONT WHEEL DRIVE

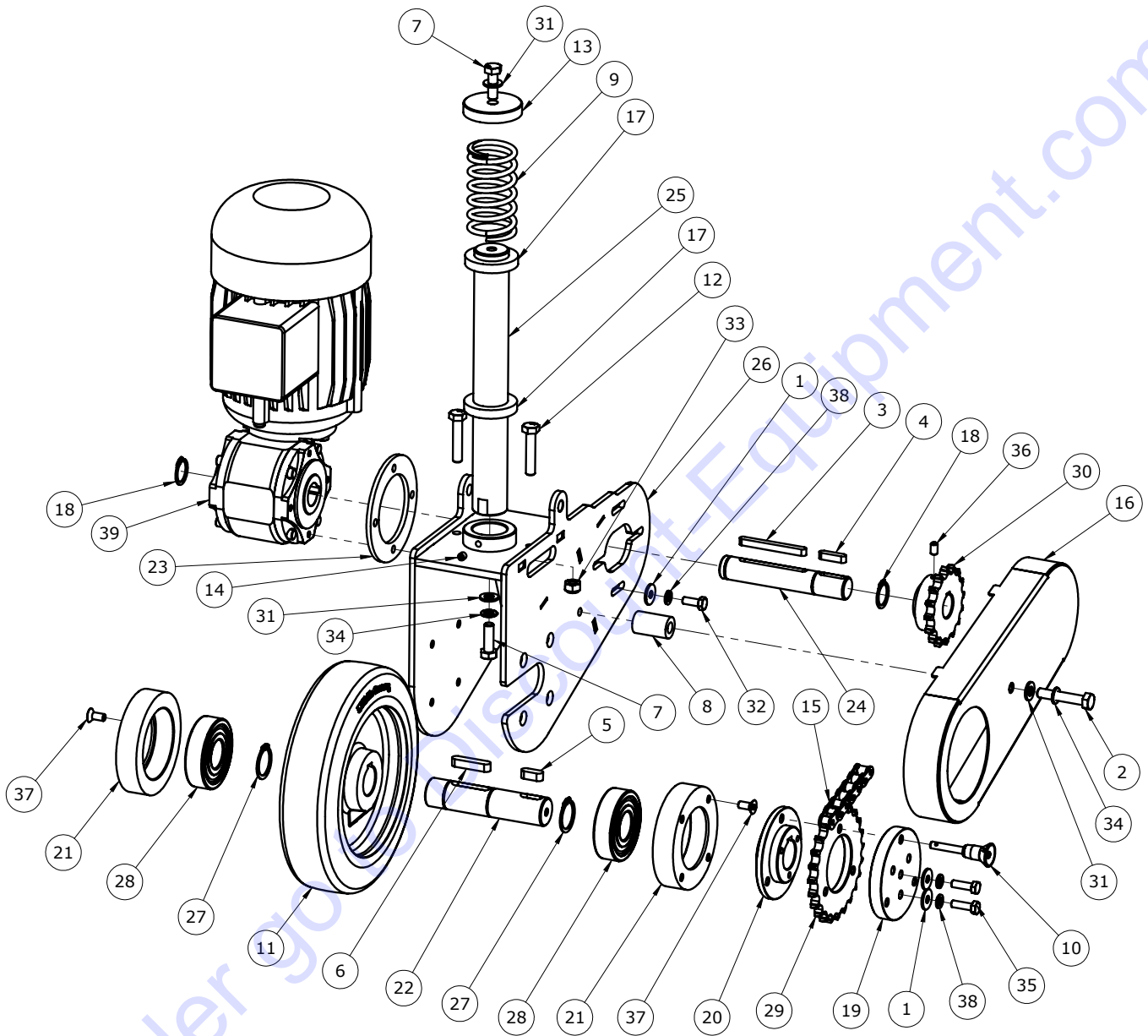

Parts List and Diagrams

FRONT WHEEL DRIVE (CONT'D)

| Item# | Part# | Description | QTY |
|-------|-----------|--|-----|
| 1 | 405278 | Washer, Flat, Fender, M6, Stainless Steel | 8 |
| 2 | 405271 | Screw, Hex Head Cap, M8x1.25 x 45, Clear Zinc | 1 |
| 3 | 405270 | Key, Metric, Rounded, 6 W x 6 H x 63 L, Steel | 1 |
| 4 | 405269 | Key, Metric, Rounded, 6 W x 6 H x 25 L, Steel | 1 |
| 5 | 405268 | Key, Metric, Rounded, 8 W x 7 H x 20 L, Steel | 1 |
| 6 | 405267 | Key, Metric, Rounded, 8 W x 7 H x 36 L, Steel | 1 |
| 7 | 405254 | Screw, Hex Head Cap, M8x1.25 x 25, Clear Zinc | 2 |
| 8 | 405114 | Spacer, Round, .38 x .75 x 1.25", Aluminum | 1 |
| 9 | 405027 | Spring, Compression, 1.68 x 3.50 x .177, Stainless Steel | 1 |
| 10 | 405023 | Pin, Quick Release, 6 x 25mm | 1 |
| 11 | 405022 | Wheel, Modified, 200mm OD x50 W x 25 Bore, w /Keyway | 1 |
| 12 | 405003 | Screw, Hex Head Bolt, M8x1.25 x 40, Class 10.9 | 2 |
| 13 | 404873 | Cap, Lift Shaft | 1 |
| 14 | 404850 | Screw, Set, Flat, M6x1.0 x 6mm Long | 1 |
| 15 | 404609 | Chain, Roller ISO 08B | 1 |
| 16 | 404530-SV | Assy Weldment Chain Guard-SV | 1 |
| 17 | 404481 | Seal, Lower, Lift Shaft | 2 |
| 18 | 404479 | Ring, Retaining, External, 20mm Shaft | 2 |
| 19 | 404475 | Plate, Adapter, Front Wheel | 1 |
| 20 | 404474 | Adapter, Front Wheel | 1 |
| 21 | 404473 | Housing, Bearing, Front Wheel | 2 |
| 22 | 404472 | Shaft, Front Wheel | 1 |
| 23 | 404469 | Spacer, Gearmotor, Front Wheel | 1 |
| 24 | 404468 | Shaft, Gearmotor, Front Wheel | 1 |
| 25 | 404467 | Shaft, Lift, Front Wheel | 1 |
| 26 | 404463-SV | Assy Weldment Bracket, Front Wheel-SV | 1 |
| 27 | 404377 | Ring, Retaining, External, Axial, 25mm, Phosphate | 2 |
| 28 | 404376 | Bearing, Ball, 25mm IDx 62 ODx 17 W, 6305-2RS1 | 2 |
| 29 | 404368 | Sprocket, Modified, 24T, 08B Roller Chain | 1 |
| 30 | 404367 | Sprocket, Modified, 16T, 08B Roller Chain | 1 |
| 31 | 401803 | Washer, Flat, M8, Clear Zinc | 3 |
| 32 | 401657 | Screw, Hex Head Cap, M6-1.0 x16.0, Clear Zinc | 4 |
| 33 | 401509 | Nut, Hex, Nylon Insert, M8-1.25, Clear Zinc | 2 |
| 34 | 401332 | Washer, Lock, M8, Clear Zinc | 2 |
| 35 | 401313 | Screw, Hex Head Cap, M6-1.0 x 20, Clear Zinc | 4 |
| 36 | 74633 | Screw, Cup Point Socket Set M6-1.0x10MM | 1 |
| 37 | 74620 | Screw, Flat Head Socket Cap, M6-1.0 x 14 | 8 |
| 38 | 74619 | Washer, Lock, M6 | 8 |
| 39 | 404370 | Gearmotor, 0.5HP, 230V/400V, 50Hz, 40:1, 3 Phase | 1 |

Parts List and Diagrams

ELECTRICAL COLLECTOR – 405244

230V 60 Hz

400V 50 Hz

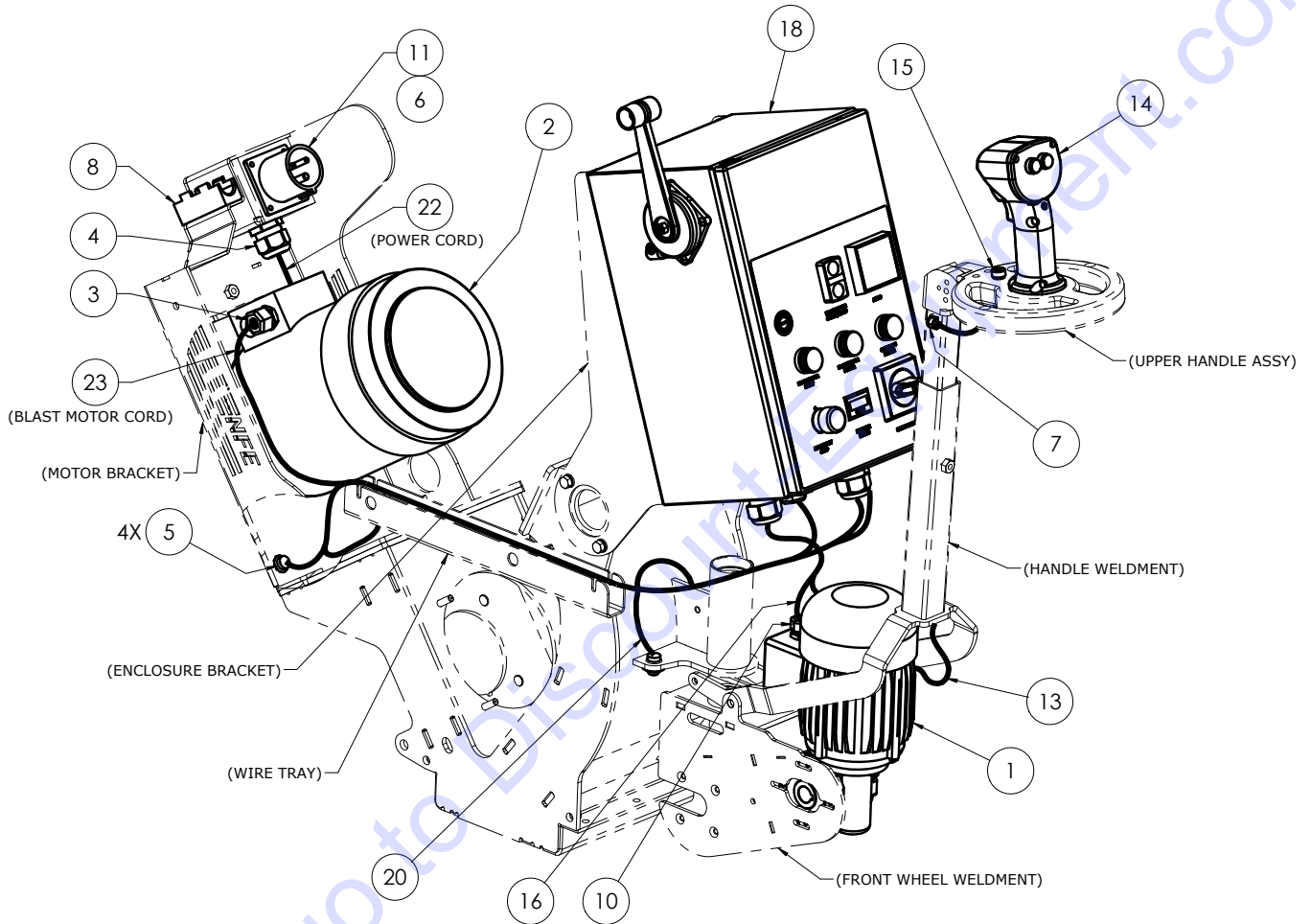

Parts List and Diagrams

ELECTRICAL COLLECTOR – 405244 (CONT'D)

230V 60 Hz

400V 50 Hz

| Item# | Part# | Description | 230V 60 Hz QTY | 400V 50 Hz QTY |
|-------|--------|---|-------------------|-------------------|
| 1 | 404370 | Gearmotor, 0.5HP, 230V/400V, 50Hz, 40:1, 3 Phase | 1 | 1 |
| 2 | 404404 | Motor 5.3 Hp, 230 V, IE2, LSES 112 M | 1 | 1 |
| 3 | 404903 | Strain Relief, M20, Black Nylon, 5-13mm ID | 1 | 1 |
| 4 | 404905 | Strain Relief, M32, Black Nylon, 11-21mm ID | 1 | 1 |
| 5 | 404919 | Work Light, 24VDC, Deutsch Connector | 4 | 4 |
| 6 | 404945 | Assy, Grounding Wire, 10AWG, Green | 1 | 1 |
| 7 | 404966 | Strain Relief, 90°, Black Nylon, .5" Mount, .25" ID | 1 | 1 |
| 8 | 404638 | Clamp, Lower, Power Cord, 10 Inch | 1 | - |
| | 405009 | Clamp, Lower, Power Cord, 8 Inch | - | 1 |
| 10 | 405085 | Strain Relief, M16, Black Nylon, 3-10mm ID | 1 | 1 |
| 11 | 406339 | Inlet, IEC 309, 2P3W, 230V, 32A, 56x56 | 1 | - |
| | 406338 | Inlet, IEC 309, 4P5W, Inverter, 400V, 16A, 56x56 | - | 1 |
| 13 | 405156 | Assy, Cord, Handle Controls, 22/8 | 1 | 1 |
| 14 | 405158 | Assy, Joystick, Wired | 1 | 1 |
| 15 | 405159 | Assy, Potentiometer, Wired | 1 | 1 |
| 16 | 405513 | Assy, Cord, Travel, Motor, 18/4, 230V | 1 | - |
| | 405774 | Assy, Cord, Travel Motor, 20/4, 400V | - | 1 |
| 18 | 405065 | Assy, Control Box, Corded | 1 | - |
| | 405771 | Assy, Control Panel, Corded, 400V, A96 | - | 1 |
| 20 | 406060 | Assy, Lighting Harness | 1 | 1 |
| 21* | 72847 | Tie, Cable, Black Nylon, 50lbs, 8" | 5 | 5 |
| 22** | 405247 | Assembly, Cord, Power, Control Panel, 8/3 | 1 | - |
| | 405790 | Assembly, Cord, Power, Control Box, 12/4 | - | 1 |
| 23** | 405309 | Assembly, Cord, Blast Motor, 12/4 | 1 | - |
| | 406054 | Assembly, Cord, Blast Motor, 16/4 | - | 1 |

*Not shown

**Included with control box (Item 18).

Parts List and Diagrams

230V CONTROL BOX – 405063

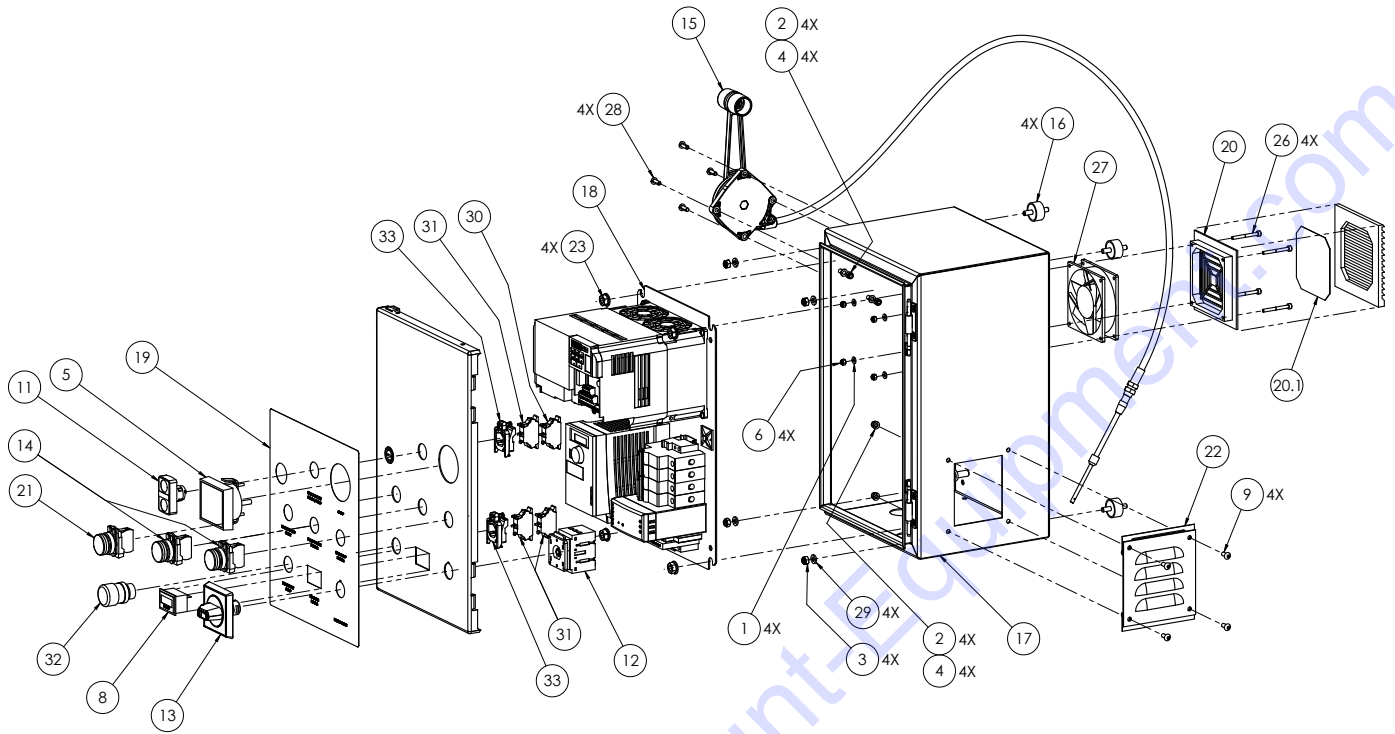

| Item# | Part# | Description | QTY |
|--------|--------|---|-----|
| 1 | 401326 | Washer, Flat, M4, Clear Zinc | 4 |
| 2 | 401327 | Washer, Flat, M5, Clear Zinc | 8 |
| 3 | 401516 | Nut, Hex, Nylon Insert, M6-1.0, Clear Zinc | 4 |
| 4 | 401517 | Nut, Hex, Nylon Insert, M5-.80, Clear Zinc | 8 |
| 5 | 401938 | Ammeter, Analog, 30A | 1 |
| 6 | 403170 | Nut, Hex, Nylon Insert, M4-0.7, Clear Zinc | 4 |
| 7* | 403235 | Nut, Keps, M6-1.0, Clear Zinc | 2 |
| 8 | 403253 | Meter, Hour, Digital, 20-300VAC, 10-300VDC, Snap-on | 1 |
| 9 | 403279 | Screw, Button Head Cap, M5-0.8 x 12, Clear Zinc | 4 |
| 10* | 403917 | Washer, External Tooth, M6, Clear Zinc | 2 |
| 11 | 404773 | Switch, 22mm, Pushbutton, Start/Stop, ZB4 Series | 1 |
| 12 | 404820 | Switch, Disconnect, 3P, 40A, Door Mount | 1 |
| 13 | 404821 | Handle, Disconnect Switch, Door Mount | 1 |
| 14 | 404822 | Indicator, 22mm, Green, 24VDC | 2 |
| 15 | 404844 | Cable, 45" Long, w/ Lever | 1 |
| 16 | 404893 | Mount, Vibration, M6x1, 1 Dia x 500 Long | 4 |
| 17 | 405021 | Enclosure, 16x10x8 | 1 |
| 18 | 405064 | Assy, Sub-Panel, 230V | 1 |
| 19 | 405077 | LABEL, CONTROL BOX, A96 | 1 |
| 20 | 405101 | Filter Assy, Fan, Louvered, 92mm, Grey | 1 |
| 20.1** | 405295 | Filter, Fan, 92mm (Filter Only) | 1 |

| Item# | Part# | Description | QTY |
|-------|--------|---|----------|
| 21 | 405103 | Indicator, 22mm, Red, 24VDC | 1 |
| 22 | 405154 | Kit, Louver, Black, w/Filter, 121x114mm, AVK34 | 1 |
| 23 | 405198 | Nut, Flange, M8-1.25, Clear Zinc | 4 |
| 24* | 405238 | Anchor, Cable Tie, Black Nylon, High Bond Adhesive, 1"x1" | 7 |
| 25* | 405245 | Kit, Wire, Control Panel | 1 |
| 26 | 405253 | Screw, Socket Head, M4 x 0.7 x 40mm, Clear Zinc | 4 |
| 27 | 405299 | Assy, Fan, 92mm, Wired | 1 |
| 28 | 405301 | Screw, Button Head Cap, M5x0.8x14, Clear Zinc | 4 |
| 29 | 405486 | Washer, Flat, M6, Clear Zinc | 4 |
| 30 | 72451 | Contact Block, NO, 10A, Spring Clamp, ZB4 Series | 1 |
| 31 | 72452 | Contact Block, NC, 10A, Spring Clamp, ZB4 Series | 3 |
| 32 | 72453 | Switch, 22mm, E-Stop, ZB4 Series | 1 |
| 33 | 72456 | Collar, Mounting, 22mm, ZB4 Series | 2 |
| 34* | 72840 | Tie, Cable, Black Nylon, 18lbs, 4" | As Req'd |
| 35* | 72842 | Tie, Cable, Black Nylon, 40lbs, 6" | As Req'd |

*Not shown

**Item 20.1 is included with Item 20 but may be ordered separately.

Parts List and Diagrams

230V SUB-PANEL ASSEMBLY – 405064

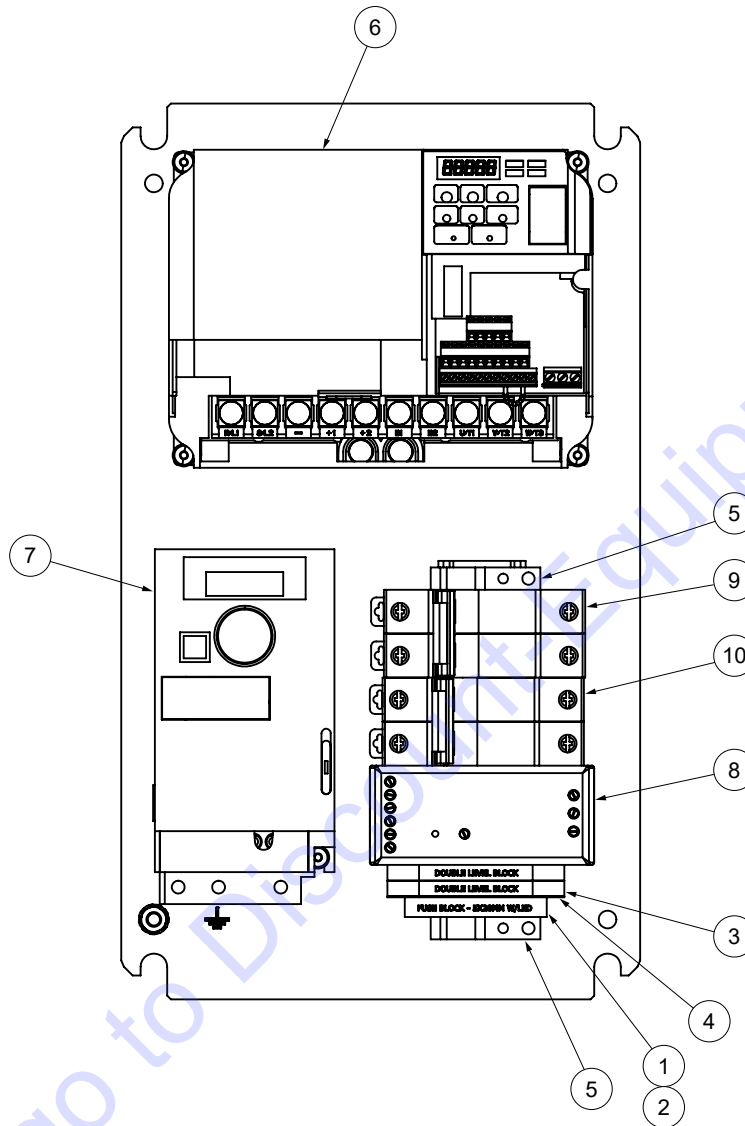

| Item# | Part# | Description | QTY |
|-------|--------|---|-----|
| 1 | 404680 | Fuse Block, 1P, LED, 90-240V, 5x20mm, DIN | 1 |
| 2* | 405130 | Fuse, 5x20mm, 2A, Time Lag | 1 |
| 3 | 404685 | Terminal Block, Double Level, Spring Clamp, CX Series | 2 |
| 4 | 404698 | End Plate, Terminal Block, Double Level, CX Series | 1 |
| 5 | 404718 | End Stop, DIN Rail, 35mm | 2 |
| 6 | 405102 | VFD, 5HP, 1Φ, 200V/240V | 1 |
| 7 | 404776 | VFD, 1/2HP, 1Φ, 200V/240V | 1 |
| 8 | 404798 | Power Supply, 24V, 60W, DIN Rail | 1 |
| 9 | 405093 | MCB, UL1077, 2P, 32A, D Trip | 1 |
| 10 | 404800 | MCB, UL1077, 2P, 5A, D Trip | 1 |

*Not shown

Parts List and Diagrams

230V POWER CORD – 405246

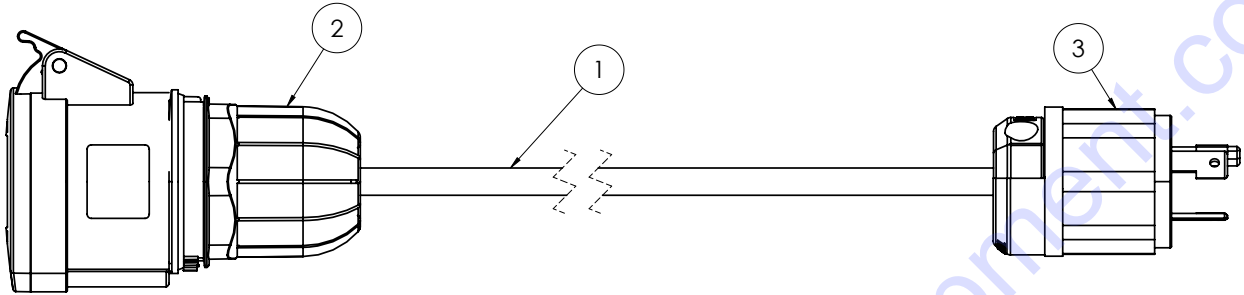

| Item# | Part# | Description | QTY |
|-------|--------|-------------------------------------|------|
| 1 | 405095 | Cord, Power, SOOW, 8/3, Black | 50FT |
| 2 | 405098 | Connector, IEC 309, 2P3W, 230V, 32A | 1 |
| 3 | 800004 | Plug, Male, L6-30P, 250VAC, 30A | 1 |

Parts List and Diagrams

A96 230V MAIN WIRING DIAGRAM

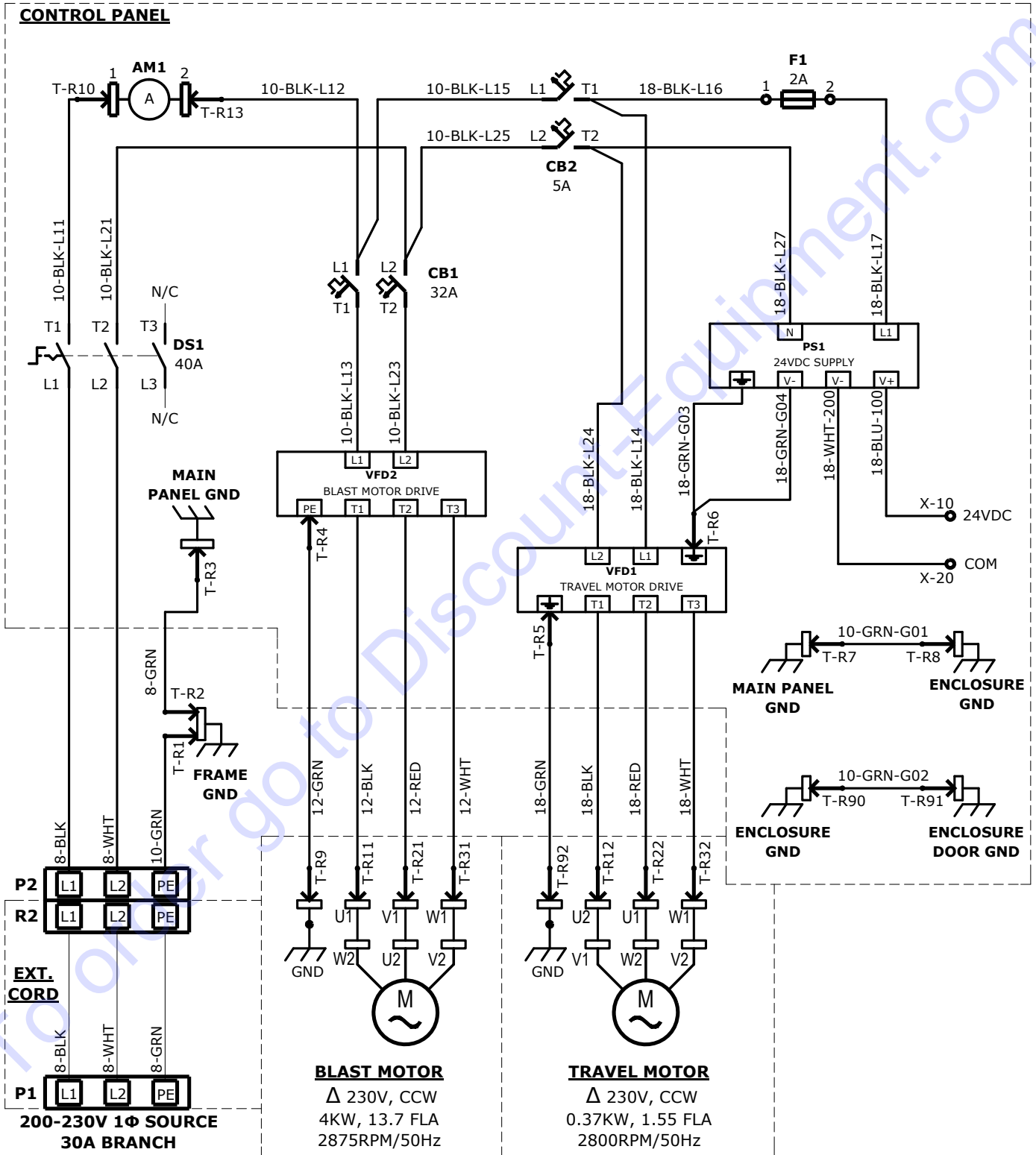

Parts List and Diagrams

A96 230V ACCESSORY WIRING DIAGRAM

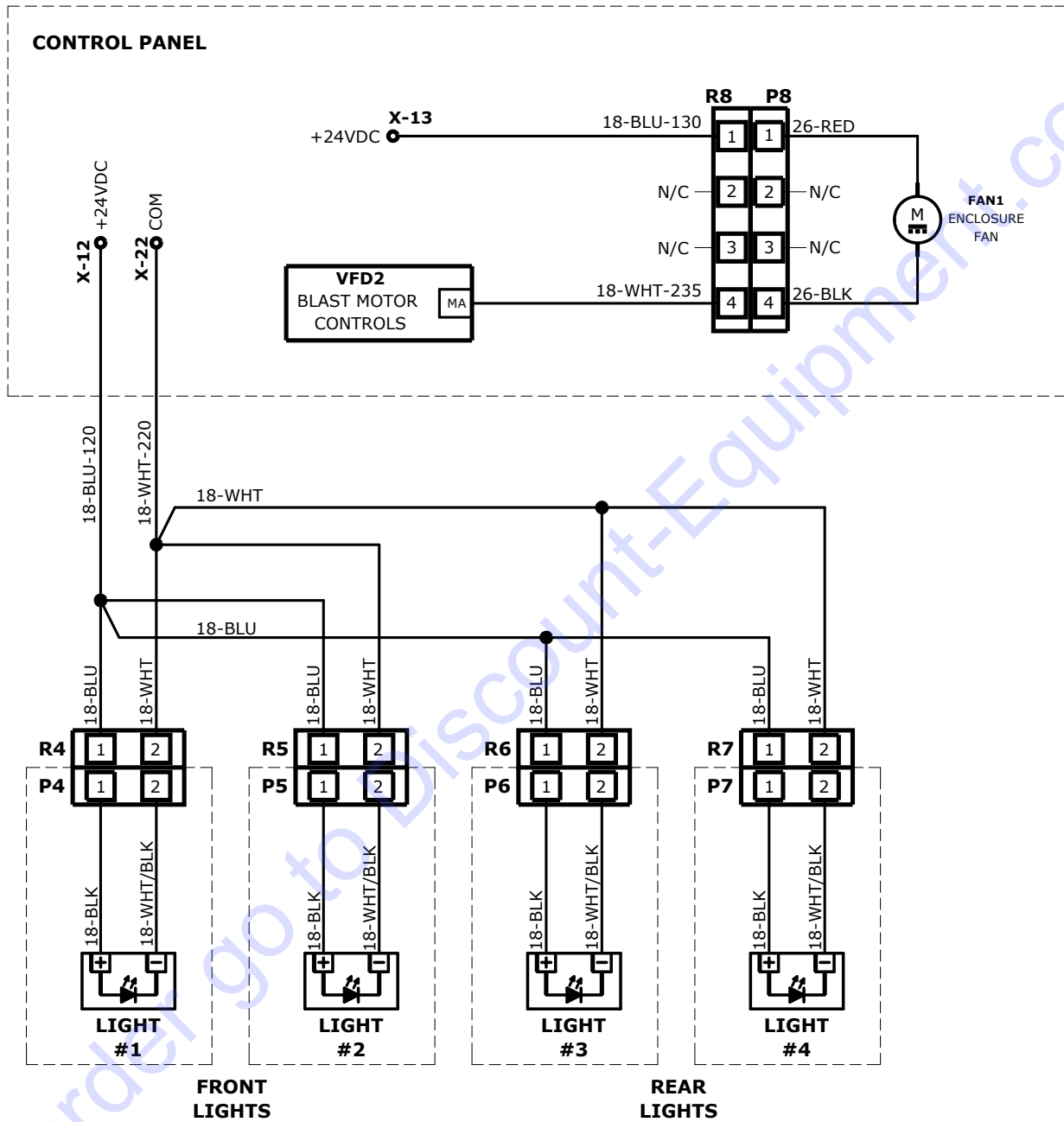

Parts List and Diagrams

A96 230V CONTROLS WIRING DIAGRAM

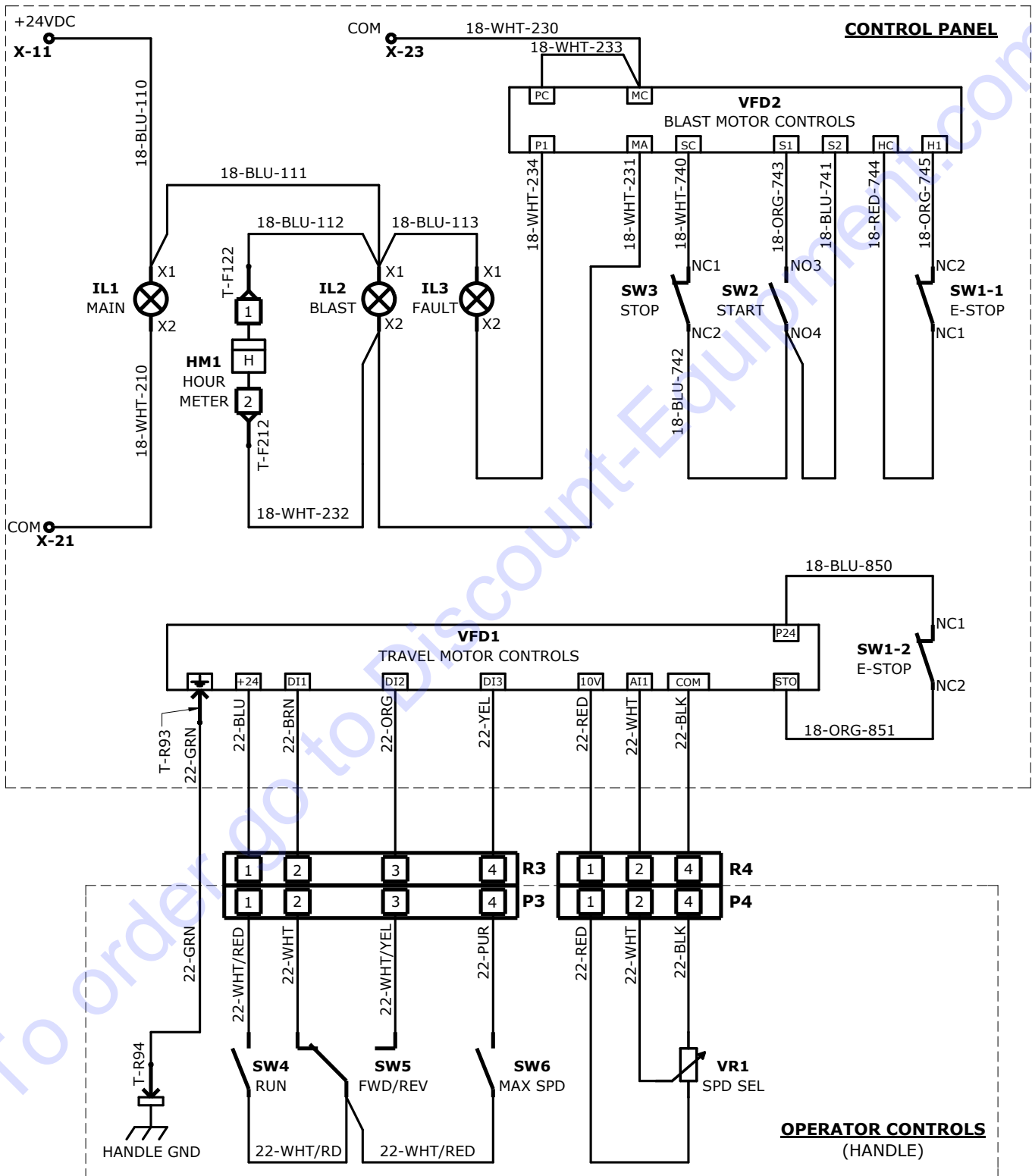

Parts List and Diagrams

400V CONTROL BOX – 405770

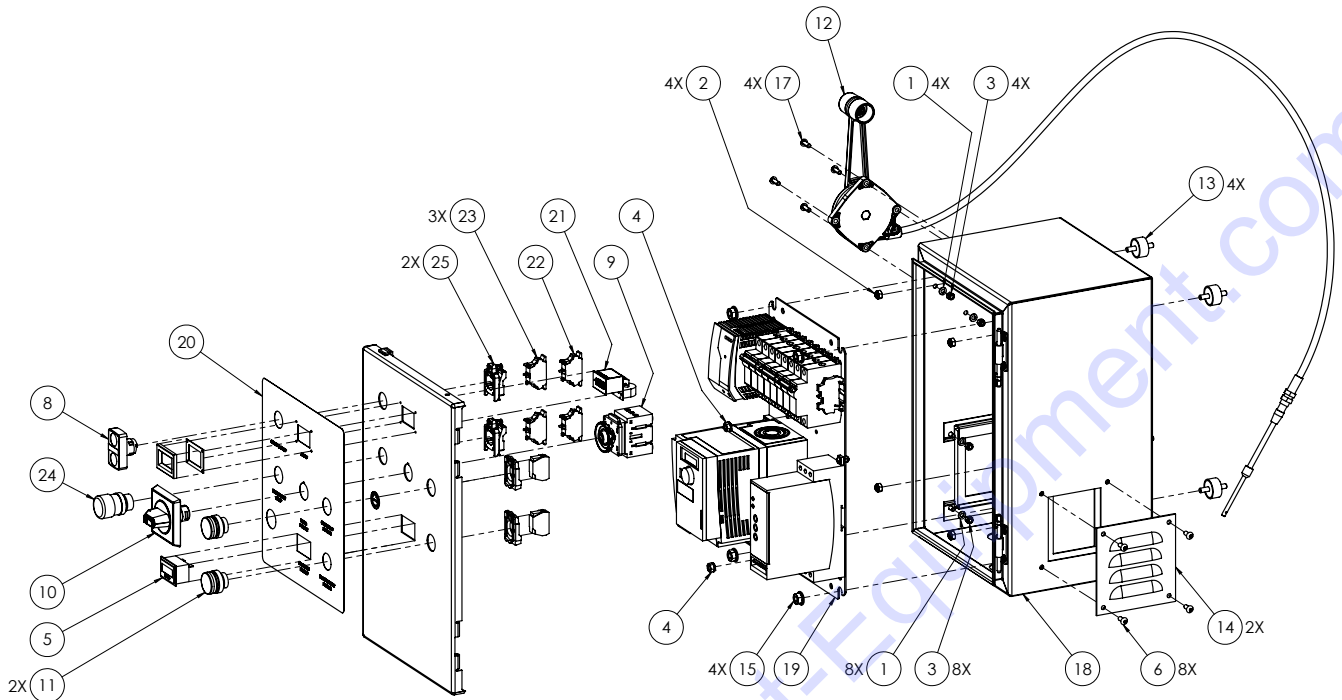

| Item# | Part# | Description | QTY |
|-------|--------|---|-----|
| 1 | 401327 | Washer, Flat, M5, Clear Zinc | 12 |
| 2 | 401516 | Nut, Hex, Nylon Insert, M6-1.0, Clear Zinc | 4 |
| 3 | 401517 | Nut, Hex, Nylon Insert, M5-.80, Clear Zinc | 12 |
| 4* | 403235 | Nut, Keps, M6-1.0, Clear Zinc | 4 |
| 5 | 403253 | Meter, Hour, Digital, 20-300VAC, 10-300VDC, Snap-on | 1 |
| 6 | 403279 | Screw, Button Head Cap, M5-0.8 x 12, Clear Zinc | 8 |
| 7* | 403917 | Washer, External Tooth, M6, Clear Zinc | 2 |
| 8 | 404773 | Switch, 22mm, Pushbutton, Start/Stop, ZB4 Series | 1 |
| 9 | 404820 | Switch, Disconnect, 3P, 40A, Door Mount | 1 |
| 10 | 404821 | Handle, Disconnect Switch, Door Mount | 1 |
| 11 | 404822 | Indicator, 22mm, Green, 24VDC | 2 |
| 12 | 404844 | Cable, 45" Long, w/ Lever | 1 |
| 13 | 404893 | Mount, Vibration, M6x1, 1 Dia x 500 Long | 4 |
| 14 | 405154 | Kit, Louver, Steel, Black, 121mm x 114mm | 2 |
| 15 | 405198 | Nut, Flanged, M8-1.25mm, Zinc Plated | 4 |
| 16* | 405238 | Anchor, Cable Tie, Black Nylon, High Bond Adhesive, 1"x1" | 1 |
| 17 | 405301 | Screw, Button Head Cap, M5x0.8x14, Clear Zinc | 4 |
| 18 | 405760 | Enclosure, 16x10x9, 400V | 1 |
| 19 | 405769 | Assembly, Sub-Panel, 400V | 1 |
| 20 | 405768 | Label, Door, 16"x10", 400V | 1 |
| 21 | 405784 | Ammeter, Digital, 20A, 5-40VDC | 1 |
| 22 | 72451 | Contact Block, NO, 10A, Spring Clamp, ZB4 Series | 1 |
| 23 | 72452 | Contact Block, NC, 10A, Spring Clamp, ZB4 Series | 3 |
| 24 | 72453 | Switch, 22mm, E-Stop, ZB4 Series | 1 |
| 25 | 72456 | Collar, Mounting, 22mm, ZB4 Series | 2 |
| 26* | 72840 | Tie, Cable, Black Nylon, 18lbs, 4" | 1 |
| 27* | 72842 | Tie, Cable, Black Nylon, 40lbs, 6" | 1 |

*Not shown

Parts List and Diagrams

400V SUB-PANEL ASSEMBLY – 405769

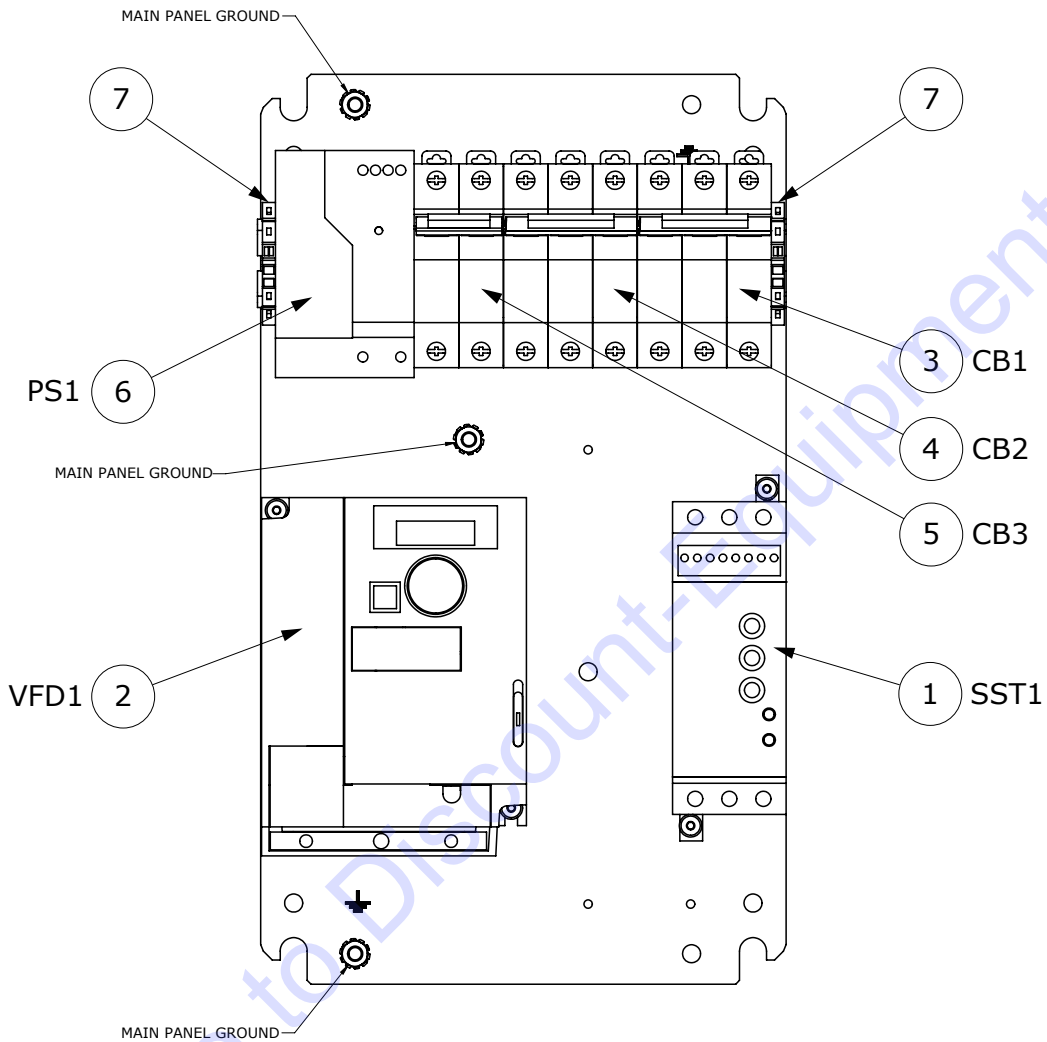

| Item# | Part# | Description | QTY |
|-------|--------|--|-----|
| 1 | 405775 | Soft Starter, 9A, 400V | 1 |
| 2 | 406265 | VFD, 1/2HP, 3Φ, 400V, Programmed | 1 |
| 3 | 405778 | Circuit Breaker, MCB, UL1077, 3P, 10A, D Trip | 1 |
| 4 | 405780 | Circuit Breaker, MCB, UL1077, 3P, 2A, D Trip | 1 |
| 5 | 405781 | Circuit Breaker, MCB, UL1077, 2P, 1A, D Trip | 1 |
| 6 | 405782 | Power Supply, 24VDC, 264-575VAC, 90W, DIN Rail | 1 |
| 7 | 405783 | End Stop, DIN Rail, 35mm, Slim | 2 |

Parts List and Diagrams

400V POWER CORD – 405614

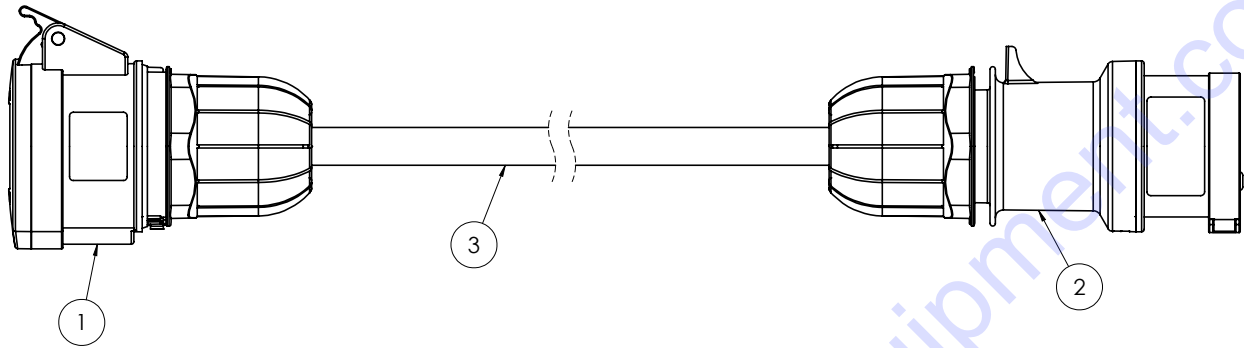

| Item# | Part# | Description | QTY |
|-------|--------|--|------|
| 1 | 405525 | Connector, IEC 309, 4P5W, 400V, 16A | 1 |
| 2 | 405526 | Plug, IEC 309, 4P5W, 400V, 16A | 1 |
| 3 | 405948 | Cord, Power, H07RN-F, 2.5mm ² /5, Black CPE | 50FT |

Parts List and Diagrams

400V MAIN WIRING DIAGRAM

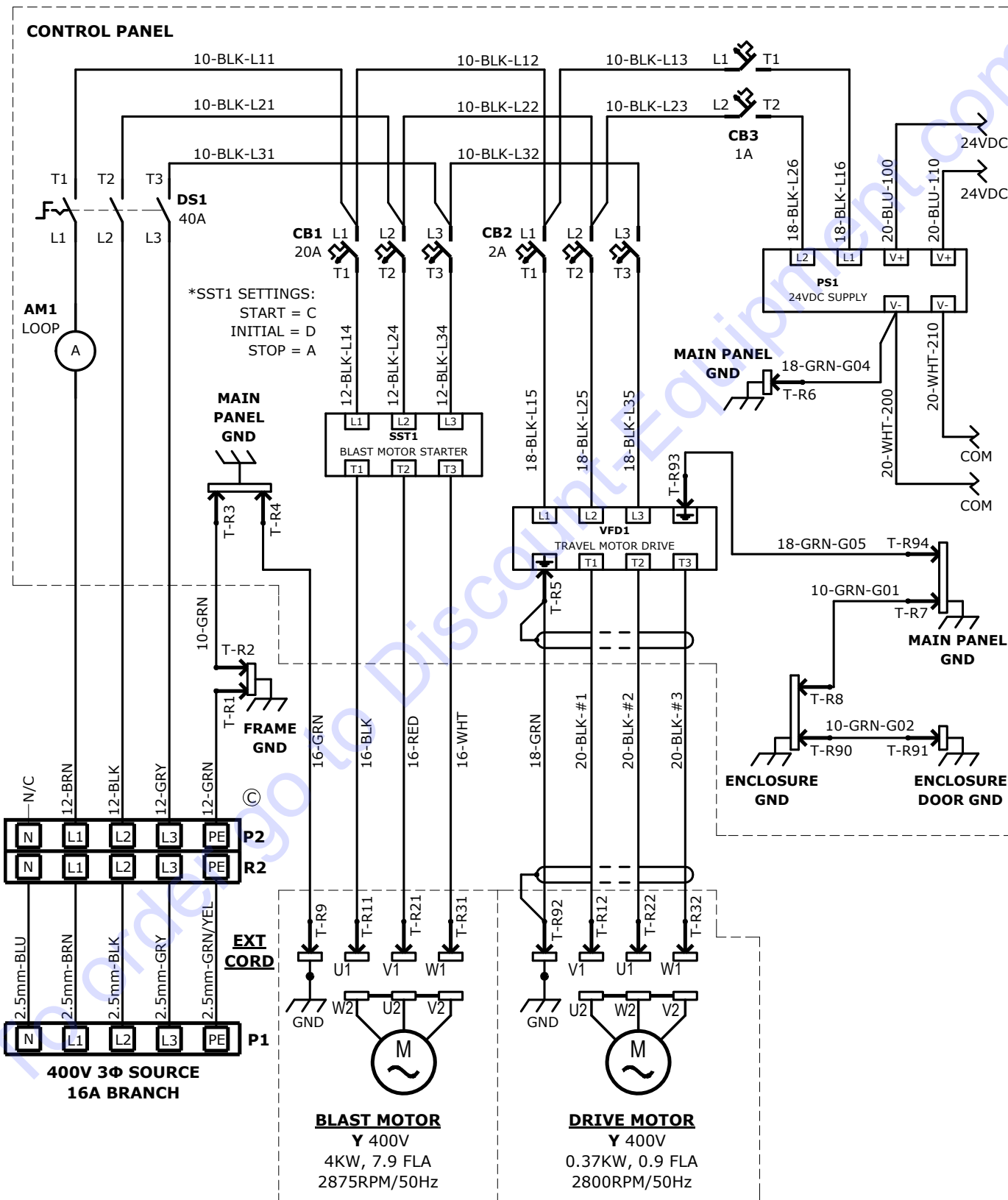

Parts List and Diagrams

400V CONTROLS WIRING DIAGRAM 1

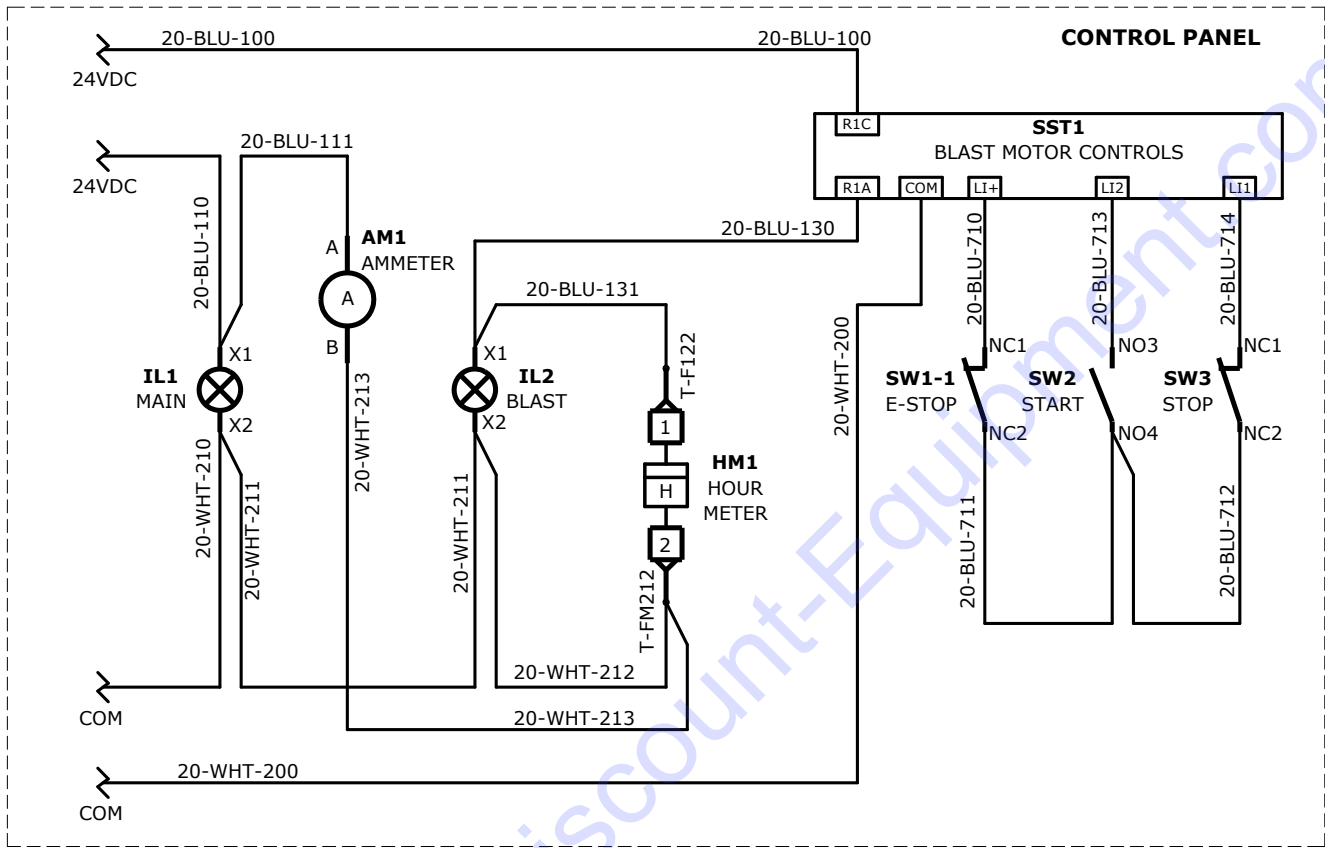

Parts List and Diagrams

400V CONTROLS WIRING DIAGRAM 2

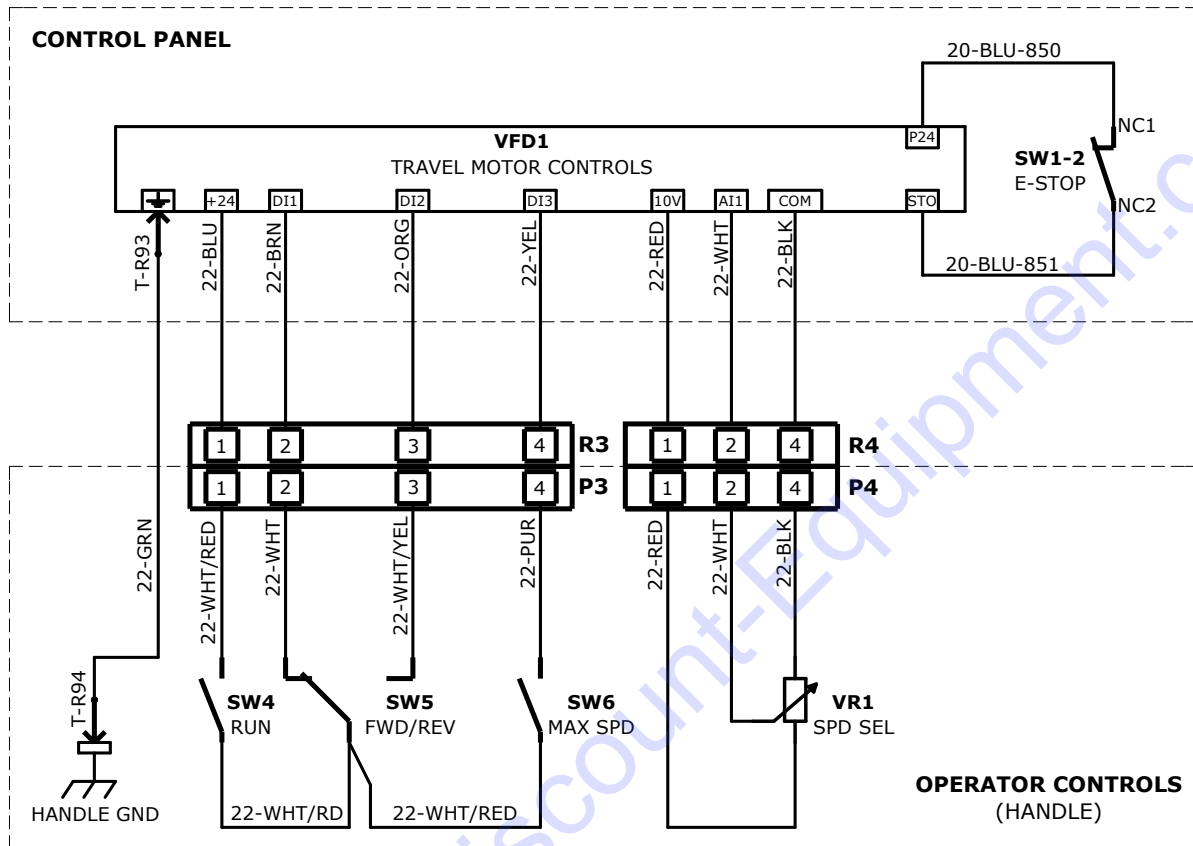

Parts List and Diagrams

400V ACCESSORIES WIRING DIAGRAM

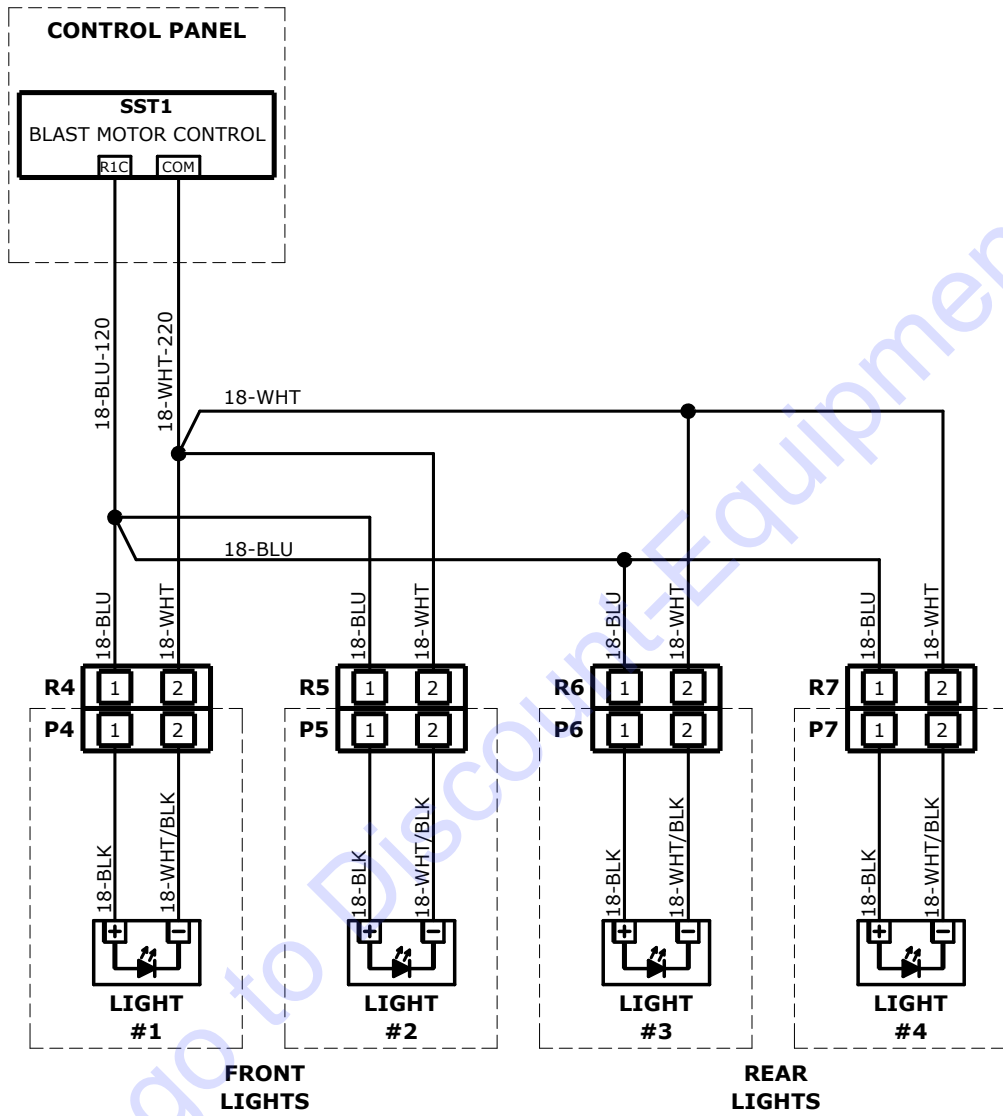

TO PURCHASE THIS PRODUCT PLEASE CONTACT US



**Equipment Financing and
Extended Warranties Available**



**Discount-Equipment.com is your online resource for
commercial and industrial quality parts and equipment sales.**

561-964-4949

visit us on line @ www.discount-equipment.com

Select an option below to find your Equipment

Search by Manufacturer

Search by Product Type

Request a Quote

We sell worldwide for the brands: Genie, Terex, JLG, MultiQuip, Mikasa, Essick, Whiteman, Mayco, Toro Stone, Diamond Products, Generac Magnum, Airman, Haulotte, Barreto, Power Blanket, Nifty Lift, Atlas Copco, Chicago Pneumatic, Allmand, Miller Curber, Skyjack, Lull, Skytrak, Tsurumi, Husquvarna Target, Stow, Wacker, Sakai, Mi-T-M, Sullair, Basic, Dynapac, MBW, Weber, Bartell, Bennar Newman, Haulotte, Ditch Runner, Menegotti, Morrison, Contec, Buddy, Crown, Edco, Wyco, Bomag, Laymor, EZ Trench, Bil-Jax, F.S. Curtis, Gehl Pavers, Heli, Honda, ICS/PowerGrit, IHI, Partner, Imer, Clipper, MMD, Koshin, Rice, CH&E, General Equipment, Amida, Coleman, NAC, Gradall, Square Shooter, Kent, Stanley, Tamco, Toku, Hatz, Kohler, Robin, Wisconsin, Northrock, Oztec, Toker TK, Rol-Air, APT, Wylie, Ingersoll Rand / Doosan, Innovatech, Con X, Ammann, Mecalac, Makinex, Smith Surface Prep, Small Line, Wanco, Yanmar