

2900 HIGH-SPEED RIDE-ON SCRAPER OPERATING & SERVICE MANUAL



Read Manual Before Operating or
Servicing Machine

401878 Rev J

**Discount
Equipment**

TO PURCHASE THIS PRODUCT PLEASE CONTACT US



**Equipment Financing and
Extended Warranties Available**



**Discount-Equipment.com is your online resource for
commercial and industrial quality parts and equipment sales.**

561-964-4949

visit us on line @ www.discount-equipment.com

Select an option below to find your Equipment

Search by Manufacturer

Search by Product Type

Request a Quote

We sell worldwide for the brands: Genie, Terex, JLG, MultiQuip, Mikasa, Essick, Whiteman, Mayco, Toro Stone, Diamond Products, Generac Magnum, Airman, Haulotte, Barreto, Power Blanket, Nifty Lift, Atlas Copco, Chicago Pneumatic, Allmand, Miller Curber, Skyjack, Lull, Skytrak, Tsurumi, Husquvarna Target, Stow, Wacker, Sakai, Mi-T-M, Sullair, Basic, Dynapac, MBW, Weber, Bartell, Bennar Newman, Haulotte, Ditch Runner, Menegotti, Morrison, Contec, Buddy, Crown, Edco, Wyco, Bomag, Laymor, EZ Trench, Bil-Jax, F.S. Curtis, Gehl Pavers, Heli, Honda, ICS/PowerGrit, IHI, Partner, Imer, Clipper, MMD, Koshin, Rice, CH&E, General Equipment, Amida, Coleman, NAC, Gradall, Square Shooter, Kent, Stanley, Tamco, Toku, Hatz, Kohler, Robin, Wisconsin, Northrock, Oztec, Toker TK, Rol-Air, APT, Wylie, Ingersoll Rand / Doosan, Innovatech, Con X, Ammann, Mecalac, Makinex, Smith Surface Prep, Small Line, Wanco, Yanmar

Table of Contents

Table of Contents	3
Features and Specifications	4
Safety	6
General Rules For Safe Operation	6
Ride-On Scraper Safety Guidelines.....	7
Hydraulic Safety.....	8
Components and Assembly	9
Charger Instructions	9
Machine Charging.....	9
Transport.....	10
Jobsite Movement.....	10
Cutting Head and Blades.....	11
Foot Pegs	13
Storage	13
Operation	14
Operating Controls.....	14
Start-Up Procedure.....	14
Shut-Down Procedure	15
Slide Plate Adjustments and Settings.....	15
Application Setup.....	16
Ditching.....	17
Maintenance Schedule	18
Troubleshooting Guide	19
Maintenance	20
Manual Slide Plate Removal.....	20
Dual Slide Plate Removal	20
Leak Maintenance	20
Check Hydraulic Oil Level.....	21
Hydraulic Oil Change Out.....	21
Change Hydraulic Cylinder	21
Change/Remove Hose	21
Change Pump.....	21
Change Valve	21
Change Wheel Motor.....	22
Change Rear Wheel	22
Change Caster.....	22
Change Motor	22
Seat Replacement	23
Remove/Replace Foot Peg.....	23
Clean Wheel Motor Build-Up.....	23
Parts List and Diagrams	24
Wiring Diagrams	40

Features and Specifications



FEATURES

Seat Switch - Ensures the machine will not function without someone in the operator seat.

18" Wheels - Designed to work on all types of applications, including debris build-up and slippery/slimy residue (e.g. double stick).

Onboard Battery Charger - Recharges onboard battery.

Adjustable Slide Plate - Affords maximum versatility in blade settings.

Forklift Cups - Makes it easier to load and unload on jobsites.

Control Levers - Move forward or in reverse, turn, and brake with easy-to-move levers.

DC Motor Pump Compartment - Provides easy access to the motor for maintenance purposes.

Adjustable Foot Rests - Adjusts to operator's level of comfort.

Cutting Head Cylinder Lift - Changes the angle of the cutting head via the control handle next to the operator seat.

Debris Deflector - Redirects debris away from the operator.

Swivel Cutting Head - Ensures continuous blade contact with the floor.

Features and Specifications

Product Specifications			
Serial Number	2900-10XXXX	2900-17XXXX	2900-30XXXX
Region	Domestic	Domestic	International
Width	24.5" (62 cm)	24.5" (62 cm)	24.5" (62 cm)
Length	55" (140 cm)	60" (152 cm)	67" (170 cm)
Height	46.5" (126 cm)	46.5" (126 cm)	46.5" (126 cm)
Unweighted (Machine Only)	1,465 lbs (665 kg)	1,601 lbs (726 kg)	See Supplemental Manual
Net Weight*	1,774 lbs (805 kg)	1,910 lbs (866 kg)	See Supplemental Manual
Power	4 HP	4 HP	4 HP
Input Power	120V / 60 Hz	120V / 60 Hz	100V / 50/60 Hz
Speed	Up to 160 ft/min	Up to 160 ft/min	Up to 160 ft/min
Body Panels	Silver Vein	Silver Vein	Black
Slide Plate	Manual Lift	Dual Lift	Dual Lift

*Net weight includes removable weights, cutting head and transport wheels.

Safety

GENERAL RULES FOR SAFE OPERATION

Before use, anyone operating or performing maintenance on this equipment must read and understand this manual, as well as any labels packaged with or attached to the machine and its components. Read the manual carefully to learn equipment applications and limitations, as well as potential hazards associated with this type of equipment. Keep manual near machine at all times. If your manual is lost or damaged, contact Discount-equipment for a replacement.

Personal

Dress properly and use safety gear.

Do not wear loose clothing; it may be caught in moving parts. Anyone in the work area must wear safety goggles or glasses and hearing protection. Wear a dust mask for dusty operations. Hard hats, face shields, safety shoes, etc. should be worn when specified or necessary.

Maintain control; stay alert.

Keep proper footing and balance, and maintain a firm grip. Observe surroundings at all times. Do not use when tired, distracted, or under the influence of drugs, alcohol, or any medication that may cause decreased control.

Keep hands away from all moving parts and tooling.

Wear gloves when changing tooling. Remove tooling when machine is not in use and/or lower cutting head to the floor.

Do not force equipment.

Equipment will perform best at the rate for which it was designed. Excessive force only causes operator fatigue, increased wear, and reduced control.

Environment

Avoid use in dangerous environments.

Do not use in rain, damp or wet locations, or in the presence of explosive atmospheres (gaseous fumes, dust, or flammable materials). Remove materials or debris that may be ignited by sparks. Keep work area tidy and well-lit - a cluttered or dark work area may lead to accidents. Extreme heat or cold may affect performance.

Protect others in the work area and be aware of surroundings.

Provide barriers or shields as needed to protect others from debris and machine operation. Children and other bystanders should be kept at a safe distance from the work area to avoid distracting the operator and/or coming into contact with the machine. Operator should be aware of who is around them and their proximity. Support personnel should never stand next to, in front of, or behind the machine while the machine is running. Operator should look behind them before backing up.

Do not come within 3 ft. of the machine's perimeter during operation.

Guard against electric shock.

Ensure that machine is connected to a properly grounded outlet. Prevent bodily contact with grounded surfaces, e.g. pipes, radiators, ranges, and refrigerators. When scoring or making cuts, always check the work area for hidden wires or pipes.

Maintenance & Repairs

Begin maintenance work only when the machine is shut down, unplugged, and cooled down.

Use proper cleaning agents.

Ensure that all cleaning rags are fiber-free; do not use any aggressive cleaning products.

Schedule regular maintenance check-ups.

Ensure machine is properly cleaned and serviced. Remove all traces of oil, combustible fuel, or cleaning fluids from the machine and its connections and fittings. Retighten all loose fittings found during maintenance and repair work. Loose or damaged parts should be replaced immediately; use only NFE parts.

Do not weld or flame-cut on the machine during repairs, or make changes to machine without authorization from NFE.

Equipment

Use proper parts and accessories.

Only use NFE-approved or recommended parts and accessories. Using any that are not recommended may be hazardous.

Ensure accessories are properly installed and maintained.

Do not permanently remove a guard or other safety device when installing an accessory or attachment.

Inspect for damaged parts.

Check for misalignment, binding of moving parts, loose fasteners, improper mounting, broken parts, and any other conditions that may affect operation. If abnormal noise or vibration occurs, turn the machine off immediately. Do not use damaged equipment until repaired. Do not use if power switch does not turn machine on and off. For all repairs, insist on only identical NFE replacement parts.

Maintain equipment and labels.

Keep handles dry, clean, and free from oil and grease. Keep cutting edges sharp and clean. Follow instructions for lubricating and changing accessories. Motor and switches should be completely enclosed at all times with no exposed wiring. Inspect cord regularly. Labels carry important information; if unreadable or missing, contact Discount-equipment for a free replacement.

Avoid accidental starting; store idle equipment.

When not in use, ensure that the machine is unplugged and breaker is set to OFF. Store in a dry, secured place. Remove tooling when storing, and keep away from children.

RIDE-ON SCRAPER SAFETY GUIDELINES

Scraping

Do not drive machine along hills or uneven surfaces.

The weight of the machine may become distributed differently if on an uneven surface. Too much of an angle could make the machine unsafe or cause it to tip over. Always keep the front of the machine facing downward while traveling up or down ramps or inclines. Do not run the machine in unsafe environments.

Inspect work area for potential hazards prior to operation.

Observe location of electrical supplies and extension cords.

Do not allow cutting heads to come into contact with any electrical supply or extension cord.

Operator must be seated before starting machine and should stay seated until motor has stopped running.

This machine is equipped with a safety switch under the seat, which requires the operator to be seated before the machine can be operated. Do not attempt the start-up procedure without first being seated on the machine.

Batteries and Chargers

Use caution; risk of explosive gases.

Batteries generate explosive gases during normal operation. Do not use near fuels, grain, dust, solvents, or other flammables; never smoke near the machine, battery, or charger.

Inspect battery and charger regularly.

Disconnect charger from wall outlet before operating. Machine should be off before connecting to a power source. Periodically inspect batteries, cables, charger, and all plug connections. Be extremely cautious when working with batteries. Do not open or tamper with batteries; doing so could cause electrical shock.

Charger Operation

Ensure proper use of charger.

- Once connected and plugged into AC power, the LED will indicate whether or not it is charging. Refer to manufacturer's charger manual.
- Only use charger on branch circuits protected by a circuit breaker or fuse that can carry the power of the charger.
- Do not use charger if it shows signs of physical stress, or if DC output leads or connector feel hot when used.
- Do not disconnect DC output clamps or connector from batteries while charger is on. This could cause an explosion.
- Failure to unplug AC power before moving equipment will damage cords, plugs, and receptacles.
- Do not over-discharge batteries, this could cause batteries to fail. Re-charge as soon as possible after discharge; if they are warm, first allow them to cool.
- Charger is not water proof, only resistant, and cannot withstand immersion, continuous exposure, or heavy rain.
- A drive lockout option will disable the drive mechanism of the machine while the charger is plugged in.
- There is a built-in Low Voltage Interrupter that continuously monitors for low voltage and will sound when voltage falls. At 44V the alarm will sound; stop immediately and recharge. At 43.5V the machine will auto-disconnect and shut down; let machine sit until batteries recover enough to drive to outlet.
- Chargers are equipped with a grounding plug.

Note: Leaving the charger plugged in does not harm the battery and is preferred to leaving the battery in a state of discharge.



WARNING: BE CAUTIOUS WHEN WORKING WITH BATTERY. IF ELECTROLYTIC ACID GETS IN THE EYES, IMMEDIATELY FLUSH OUT WITH COLD, FRESH WATER FOR AT LEAST 10 MINUTES AND GET MEDICAL HELP.



WARNING: ONLY USE BATTERY/CHARGER CONFIGURATIONS SPECIFICALLY APPROVED BY NFE. USE OF A DIFFERENT OR INCORRECT CONFIGURATION HAS A HIGH RISK OF LEADING TO FIRE, PREMATURE BATTERY FAILURE, DAMAGE TO MACHINE, AND/OR BODILY INJURY.



CAUTION: THE RETURN CAPACITY WHEN CHARGING THE BATTERY IS NOT 1-TO-1. ENSURE THAT BATTERY IS ALLOWED TO CHARGE FOR A GREATER PERIOD OF TIME THAN IT WAS USED (IF NOT COMPLETING A FULL CHARGE). FOR MAXIMUM BATTERY LIFE, FULLY RECHARGE BATTERY (LED WILL APPEAR SOLID GREEN) AT LEAST TWICE PER WEEK. FAILURE TO DO SO MAY RESULT IN SHORTER RUNTIMES AND PREMATURE BATTERY FAILURE.



WARNING: GRINDING/CUTTING/DRILLING OF MASONRY, CONCRETE, METAL AND OTHER MATERIALS CAN GENERATE DUST, MISTS AND FUMES CONTAINING CHEMICALS KNOWN TO CAUSE SERIOUS FATAL INJURY OR ILLNESS, SUCH AS RESPIRATORY DISEASE, CANCER, BIRTH DEFECTS OR OTHER REPRODUCTIVE HARM. IF YOU ARE UNFAMILIAR WITH THE RISKS ASSOCIATED WITH THE PARTICULAR MATERIAL BEING CUT, REVIEW THE MATERIAL SAFETY DATA SHEET AND/OR CONSULT YOU EMPLOYER, THE MATERIAL MANUFACTURER/SUPPLIER, GOVERNMENTAL AGENCIES SUCH AS OSHA AND NIOSH AND OTHER AUTHORITIES ON HAZARDOUS MATERIALS. CALIFORNIA AND SOME OTHER AUTHORITIES, FOR INSTANCE, HAVE PUBLISHED LISTS OF SUBSTANCES KNOWN TO CAUSE CANCER, REPRODUCTIVE TOXICITY, OR OTHER HARMFUL EFFECTS. CONTROL DUST, MIST AND FUMES AT THE SOURCE WHERE POSSIBLE. IN THIS REGARD USE GOOD WORK PRACTICES AND FOLLOW THE RECOMMENDATIONS OF THE MANUFACTURER/SUPPLIER, OSHA/NIOSH, AND OCCUPATIONAL AND TRADE ASSOCIATIONS. WHEN THE HAZARDS FROM INHALATION OF DUST, MISTS AND FUMES CANNOT BE ELIMINATED, THE OPERATOR AND ANY BYSTANDERS SHOULD ALWAYS WEAR A RESPIRATOR APPROVED BY OSHA/MSHA FOR THE MATERIAL BEING CUT.

Safety

HYDRAULIC SAFETY

Maintaining a Safe Work Environment

Establishing a safe work environment in and around your hydraulic equipment is extremely important. The easiest and most effective way to avoid problems is to make sure associates understand their equipment, know how to operate the machines safely, and recognize the dangers if handled carelessly. A few things to be aware of are:

- **Pressure:** Hydraulic fluid under pressure is dangerous and can cause serious injury. Never look for a leak when unit is under pressure. Using your hand could cause serious injury. A few common ways to encounter hydraulic fluid under pressure include:
 - Pinhole: Fluid under pressure can cause serious injury. It can be almost invisible escaping from a pinhole, and it can pierce the skin into the body.



DANGER: DO NOT TOUCH A PRESSURIZED HYDRAULIC HOSE ASSEMBLY WITH ANY PART OF THE BODY. IF FLUID PUNCTURES THE SKIN, EVEN IF NO PAIN IS FELT, A SERIOUS EMERGENCY EXISTS. OBTAIN MEDICAL ASSISTANCE IMMEDIATELY. FAILURE TO DO SO COULD RESULT IN LOSS OF THE INJURED BODY PART OR DEATH.

- Leak: Keep fittings and hoses tight. Only check and service when not under pressure. Leaking hydraulic fluid is hazardous; in addition to making workplace floors slippery and dangerous, it also contaminates the environment. Before cleaning an oil spill, always check EPA, state, and local regulations.
 - Burst: Whether due to improper selection or damage, a ruptured hose can cause injury. If it bursts, a worker can be burned, cut, injected, or may slip and fall.
 - Coupling Blow-Off: If the assembly is not properly made or installed, the coupling could come off and hit or spray a worker, possibly resulting in serious injury. Never operate machine without guards.
- **Flammability:** When ignited, some hydraulic fluids can cause fires and/or explode. With the exception of those comprised primarily of water, all hydraulic fluid is flammable (including many “fire-resistant” hydraulic fluids) when exposed to the proper conditions. Leaking pressurized hydraulic fluids may develop a mist or fine spray that can flash or explode upon contact with a source of ignition. These explosions can be very severe and could result in serious injury or death. Precautions should be taken to eliminate all ignition sources from contact with escaping fluids, sprays or mists resulting from hydraulic failures. Sources of ignition could be electrical discharges (sparks), open flames, extremely high temperatures, sparks caused by metal-to-metal contact, etc.



CAUTION: NEVER USE YOUR HANDS TO CHECK FOR LEAKS OVER HOSE OR HYDRAULIC CONNECTIONS. USE A PIECE OF CARDBOARD TO LOCATE A PRESSURIZED LEAK. FOR LOW PRESSURE LEAKS (DRIPS), USE A RAG TO CLEAN THE AREA AND DETERMINE WHERE THE LEAK ORIGINATES.

- **Mechanical:** Hydraulic fluid creates movement, which means some equipment may move. Observe surroundings and equipment at all times.
- **Moisture:** Do not use in wet or high moisture conditions.
- **Electrical:** Faulty wiring can be an electrical hazard. A regular preventive maintenance program should always include a wiring check. If applicable, disconnect battery before servicing.
- **Temperature:** Because this machine operates at a relatively low pressure, overheating is not common. If surface of tank becomes too hot to touch by hand (above 130°F or 55°C), shut off machine and allow it to cool.

Hydraulic Fluid

Only use Texaco Rando 46 Hydraulic Oil or compatible fluid like ISO or AW #46 from a brand name manufacturer. Non-compatible fluids could cause damage to unit or serious injury.

Components and Assembly

CHARGER INSTRUCTIONS

See Ride-On Safety Guidelines for charger safety and instructions.

Before making AC connections, refer to the requirements on the charger ID label.

This battery charger must be grounded to reduce the risk of electric shock. Chargers are equipped with a grounding type plug.

If an extension cord must be used, ensure it is in good condition. Use the one provided with the machine. The use of an improper extension cord could result in a risk of a fire or electric shock. Locate all cords so that they will not be stepped on, tripped over, or otherwise subjected to damage or stress.



FIG. 1

MACHINE CHARGING

This machine has an onboard charger (Figure 1).

1. Connect to power source using the properly sized extension cord. **Note:** *Not using the proper extension cord could cause improper charging and/or charger damage. Only use extension cord provided with machine.*
2. Complete charging sequence. Refer to Charger manual for more details.
3. Disconnect cord from the power source. Ensure cord and plug are completely secured to the machine. **Note:** *Cord can fall under machine which could damage cord and/or plug.*
4. Release red emergency stop button.



CAUTION: WHEN ALARM SOUNDS, IMMEDIATELY MOVE MACHINE TO OUTLET FOR CHARGING.



CAUTION: THE CHARGER IS **NOT** WATER PROOF, IT IS WATER RESISTANT. IT CANNOT WITHSTAND IMMERSION, CONTINUOUS EXPOSURE (SUCH AS PRESSURE WASHERS OR HOSES), OR HEAVY RAIN.



WARNING: DISCONNECT FROM POWER SOURCE BEFORE OPERATING. FAILURE TO DO SO WILL RESULT IN MACHINE NOT OPERATING.



WARNING: ELECTRICAL SHOCK HAZARD. ONLY USE NATIONAL'S APPROVED CHARGING SYSTEM.



WARNING: ALWAYS FIND A SAFE PLACE FOR RECHARGING POWER PACKS WITH GOOD VENTILATION AWAY FROM SPARKS OR FLAME SOURCES AND AWAY FROM BYSTANDERS. ROPE OFF IF NECESSARY.

Components and Assembly

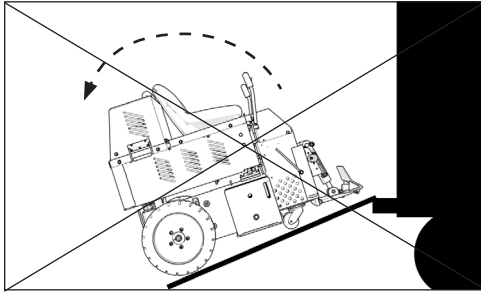

FIG. 2

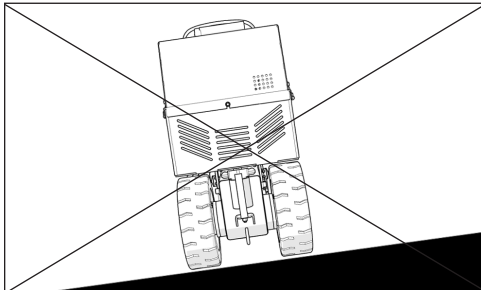
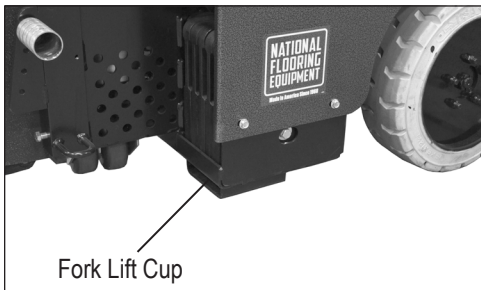

FIG. 3



Fork Lift Cup

FIG. 4



FIG. 4.1

TRANSPORT

- Secure machine with ratchet straps during transport. Proper securing straps need to be rated at least twice the weight of the machine.
- Chock wheels to keep machine from rolling, but do not use them on their own.
- Hydraulic levers should be straight up in the neutral position, not locked in the forward or backward positions.
- Lift machine off swivel caster by lowering cutting head for better stabilization. Use transport wheels when doing this.
- Remove blade, cutting head, and added weights during transport.
- Cutting head and slide plate can be removed to make machine more compact.
- Never leave machine unattended on an incline.



CAUTION: MACHINE IS BACK HEAVY. DO NOT RUN ON STEEP INCLINE THIS COULD CAUSE MACHINE TO TIP OVER! (FIGURE 2). DO NOT USE A RAMP TO MOVE MACHINE.



WARNING: MACHINE HAS A SWIVEL FRONT CASTER. NEVER SIDE HILL (FIGURE 3) THE MACHINE ON AN INCLINE WITHOUT POWER, THE FRONT CASTER WILL CAUSE MACHINE TO SWING TO THE LOWEST POINT. IF IT IS NECESSARY TO RUN MACHINE ON AN INCLINE, RUN MACHINE ON CUTTING HEAD. PLACE AT LEAST A 8" CUTTING HEAD IN MACHINE. TO KEEP FROM DAMAGING FLOOR, CLAMP A PIECE OF CARPET INTO CUTTING HEAD. THIS WILL GIVE POSITIVE CONTACT WITH THE FLOOR WHEN POWER IS DISENGAGED FROM THE WHEELS.

Dock Heights

It is best to load or unload the machine from a level dock height.

Power Gate

A power gate can be used when the dock height is not available. Ensure gate is properly rated for 3,000 lb (1,361 kg). To better secure machine, place onto the lowered cutting head; raise machine off the caster. Tie machine down and chock wheels.

Forklift Cups

There are two forklift cups mounted under the front of the machine (Figure 4). Slide forklift forks through the cups, then slide as far back as possible (Figure 4.1). Before lifting machine, secure it to the forklift with 3,000 lb (1,361 kg) or heavier straps or a chain. Tilt forks back to lift machine.

Palletizing

Only use a solid platform pallet. If a solid platform pallet is not available, place a piece of $\frac{3}{4}$ " plywood on top of a pallet. Using a forklift, with the forks inserted in the forklift cups, place machine on pallet. Use properly rated ratchet straps to secure machine to pallet.

JOBSITE MOVEMENT

Taping Wheels

Taping the wheels with a wide masking tape helps to prevent dirtying or damaging the floors during move-in and move-out.

Components and Assembly

Transport Wheels

The front wheel assembly (Figure 5) is included and very helpful when moving a machine around on a jobsite or loading a machine that is not on a pallet. It allows machine stability and safe transportation over most surfaces. It is quick and easy to attach or detach.

1. Raise slide plate so the bottom of the slide plate is higher or even with the bottom of the guide channels, 6"-8" (15.25-20.3 cm) is ideal.
2. Raise cylinder; insert front wheel assembly into cutting head.
3. Secure with pin.

When finished, the caster wheels should swivel freely and the front wheel plate should be parallel with the floor.



FIG. 5

Moving Machine without Power (Pushing Machine)

Forward: To move the machine forward, levers need to be pushed forward. To lock levers in place, connect a bungee strap from each lever (pushing levers forward), pulling straps down to and connecting to the front plate (Figure 6). Never leave machine unattended with strap holding levers open.



WARNING: PROVIDE BARRIERS OR SHIELDS AS NEEDED TO PROTECT OTHERS FROM DEBRIS AND MACHINE OPERATION. OPERATOR SHOULD BE AWARE OF THE PROXIMITY OF OTHERS.

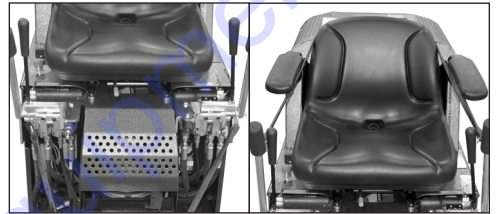

FIG. 6

FIG. 6.1

Backward: To move machine backward, levers need to be pulled backwards. To lock levers in place, connect a bungee-strap from each lever (pushing levers backward), Pulling straps to the back of the machine and connecting behind the seat or the rear of the machine (Figure 6.1). Never leave machine unattended with strap holding levers open.



WARNING: REMOVE STRAPS BEFORE STARTING MOTOR. FAILURE TO DO SO WILL MAKE MACHINE MOVE AND MAY CAUSE DAMAGE AND/OR BODILY INJURY.

Moving Machine on Caster

Moving a weighted machine on only the front caster and not on the cutting head or the front wheel assembly can make the machine sluggish. It may also turn hard to the right or left.

CUTTING HEAD AND BLADES

Matching the correct cutting head, blade size, blade angle, and added weight to the machine is important. For every material being removed, there is an optimum blade width, thickness, sharpness, angle, and bevel (up or down).

The machine is supplied with a 12" cutting head. Having additional cutting heads will save time on the job. Insert blades into the extra cutting heads before starting a job. When the blade is dull, take out the cutting head and replace it with another.

Shear Point

The shear point is the point where material to be removed will cut cleanly from the floor. If the blade is too wide, too dull, or too steep the shear point is lost.

Inserting the Cutting Head

1. With machine off, insert desired cutting head into cutting head holder.
2. Secure with cutting head clip.

Components and Assembly

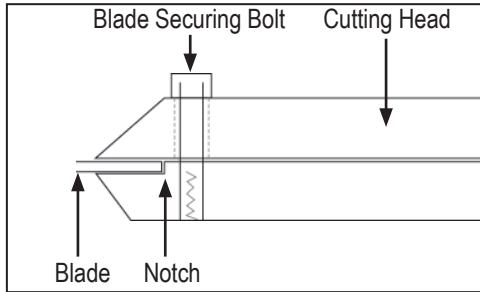

FIG. 7

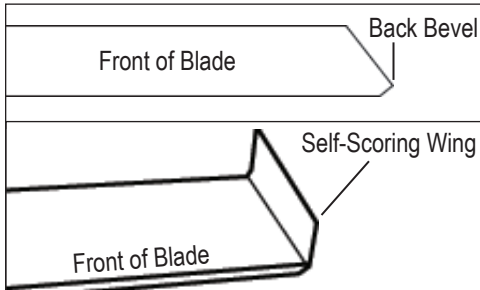

FIG. 8

Swivel Head

The swivel head keeps the blade in contact with the floor even when the floor is uneven. When using a flat blade, turning the head over 180° provides another sharp edge on the blade without having to replace the blade.

Inserting or Changing Blades

Sharp blades are imperative for good performance.

1. Using a 3/4" socket wrench, loosen bolts on cutting head. Quantity of bolts will vary depending upon cutting head size.
2. Insert blade into the cutting head to back of notch (Figure 7); tighten firmly.

Note: A cordless 3/8" drive impact wrench will speed up this process.

Inserting a Shank Blade

Shank blades do not require a cutting head.

1. Insert desired shank blade into cutting head holder.
2. Secure with cutting head clip.

Self-Scoring Blades

Instead of pre-scoring a job for soft goods (e.g. carpet, vinyl, linoleum, membrane), the self-scoring blades automatically do the scoring. It is important to keep the "wings" on a self-scoring blade sharp.



WARNING: BLADES ARE SHARP, USE EXTREME CAUTION. ALWAYS WEAR GLOVES AND SAFETY GLASSES WHEN HANDLING BLADES. NEVER CHANGE CUTTING HEAD OR SERVICE BLADES WHILE MACHINE IS RUNNING.

Components and Assembly

Blade Setting

- Proper blade size and placement, depending on material and sub-floor type, affects performance.
- For better results during difficult removal applications use a smaller blade.
- Start with a narrow blade, then increase blade size to optimize cutting pass. Narrower blades work easier than wider blades and usually clean the floor better. Wider is not always better or faster.
- Normally, bevel on blade is up for concrete (Figure 9); bevel down for wood (Figure 9.1)
- Dull blades greatly affect the performance of the machine and reduce cutting ability, sharpen or replace as needed.
- After removing a portion of material, clear the work area of debris. This will give the machine maximum performance and help to keep the work area safe.

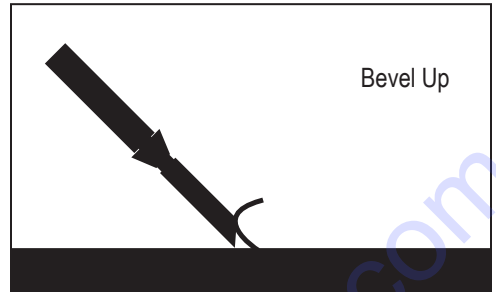

FIG. 9

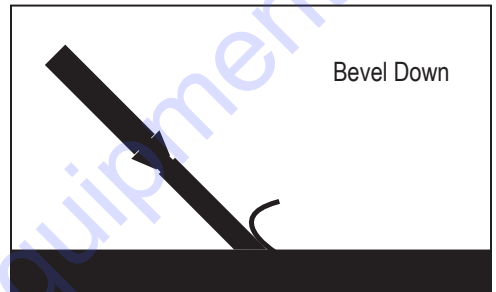

FIG. 9.1

FOOT PEGS

Rest feet on foot pegs while operating machine. Foot pegs are adjustable. Ensure securing knob is tightened.

STORAGE

When the machine is in storage, disconnect the blue plug (Figure 10) and turn circuit breaker to "OFF" (Figure 11).

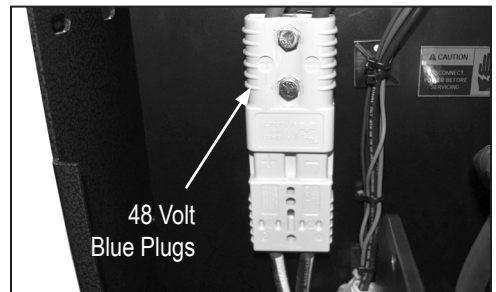

FIG. 10

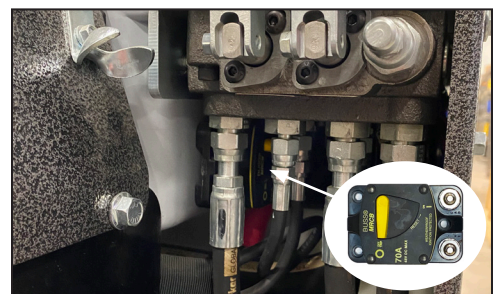

FIG. 11

Operation



FIG. 12



FIG. 13



FIG. 14



FIG. 15

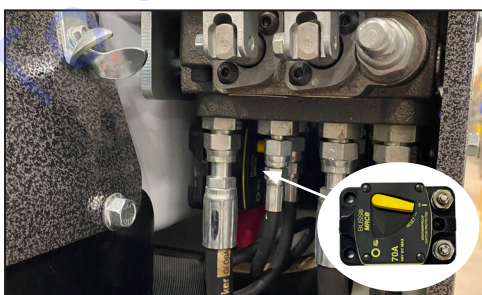

FIG. 16

OPERATING CONTROLS

Power On Button/Key (Figure 12)

Never use the Power On button/key as a method for speed control. Speed control is achieved by the hydraulic valve only. Using the On/Off switch repeatedly will cause excessive wear, causing premature failure of electrical components.

Hydraulic Levers (Figure 13)

The hydraulic levers steer the machine. For even movement, move levers slowly. Fast movement of control levers will result in jerky, uneven movement.

- To move the machine forward, push both levers forward $\uparrow\uparrow$.
- To move the machine in reverse, pull both levers backward $\downarrow\downarrow$.
- To turn the machine quickly to the right, move the left lever forward and the right lever backward $\uparrow\downarrow$.
- To turn the machine quickly to the left, move the left lever backward and the right lever forward $\downarrow\uparrow$.
- To turn the machine slowly to the right or left, push or pull only the right or left lever forward \uparrow or \downarrow .
- Putting the levers in the center/neutral position causes the wheels to lock-up.
- Correcting direction while moving forward is accomplished by slightly reducing pressure on one lever or the other while moving.

Emergency Stop Switch (Figure 14)

The emergency stop switch is designed to immediately cut power to the system. It must be reset in order to restart the machine.

Seat Switch

The seat has a safety switch. Operator must be properly positioned for machine to run.

Cylinder Lift Lever (Figure 15)

The cylinder lift lever raises and lowers the cylinder and cutting head. After setting the slide plate to proper height, use the cylinder lift lever to set blade to proper cutting angle.

- To raise the cutting head, pull back \downarrow on the cylinder lift lever.
- To lower the cutting head, push the cylinder lift lever forward \uparrow .
- Continuing to push the cylinder lift lever forward will adjust the angle of the cutting head. This will also jack up the front of the machine for maintenance purposes.

START-UP PROCEDURE

1. Verify 70 Amp circuit breaker is in "ON" position (Figure 16).
2. Verify 48V blue plugs are firmly connected.
3. Operator should be properly positioned on seat.
4. Twist emergency stop (Figure 14) up.
5. Push green "ON" button (domestic only) or turn the key (international only).
6. Maneuver machine with hydraulic levers (Figure 13).

SHUT-DOWN PROCEDURE

The machine will stop when the operator is no longer seated, or when the emergency stop is engaged.

Remove blade or drop cutting head to the floor when machine is not in use.

SLIDE PLATE ADJUSTMENTS AND SETTINGS

Manual Lift (Figure 17)



WARNING: WHEN ADJUSTING THE SLIDE PLATE, KEEP FEET AND HANDS OUT FROM UNDERNEATH THE CUTTING HEAD AND SLIDE PLATE. FAILURE TO DO SO COULD CAUSE SEVERE BODILY INJURY. WHEN BOLTS ARE REMOVED FROM THE SLIDE PLATE, THE CUTTING HEAD AND SLIDE PLATE WILL DROP TO THE FLOOR.

- Loosen the four bolts on the front of the slide plate with a 1-1/8" wrench. Slide plate up or down to achieve the desired height of the cutting head. Firmly tighten all four bolts when finished.
- A low setting orients the slide plate approximately 1" (2.5 cm) off the floor. This is for normal removal of most materials.
- A high setting orients the slide plate approximately 6" (15 cm) off the floor. This is for re-scraping glue and some thin-soft coatings.

Dual Lift (Figure 18)

- Prior to adjusting the dual lift hydraulic slide plate, ensure the channel guide is free of any debris and the machine is safely positioned on a flat surface.
- To set the height of the hydraulic slide plate start, adjust the angle of the cutting head holder with the cylinder lift lever. Pull back on the cutting head lever and raise the cutting head holder to an angle higher than the bottom of the slide plate.
- The lever adjacent to the right hand control lever raises and lowers the hydraulic slide plate. To lower the slide plate, push forward on this lever. To raise the slide plate, pull back on the lever.

Slide Plate Settings

While the hydraulic slide plate can be adjusted to multiple positions, there are two basic slide plate settings:

- **Low Setting:** The hydraulic slide plate is positioned 1" (2.5 cm) off the floor. This setting is most commonly used during initial scraping or removal applications; such as carpet, VCT, ceramic tile and wood flooring. (Note: The "low" setting on older model hydraulic slide plates may stop the plate within one to two inches of the floors surface.)
- **High Setting:** The hydraulic slide plate is positioned 6" (15 cm) off the floor or in most cases flush with the bottom of the slide plate channel guide. This setting is most often used for re-scraping glues, mastics, thin sets and soft coating.

Steep Cutting Head Angle

A steep cutting head angle is only used for re-scraping. Raise the slide plate so the bottom of the plate is even with or higher than the bottom of the guide channels (Figure 19). If the slide plate is not raised, the operator will not have a clear view of the cutting head and the machine will be raised to an unsafe operating height (Figure 19.1).

Note: Operating the machine with a steep cutting head angle can sometimes cause the machine to jump and buck.



FIG. 17



FIG. 18

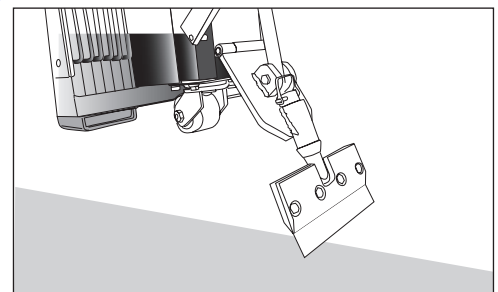

FIG. 19

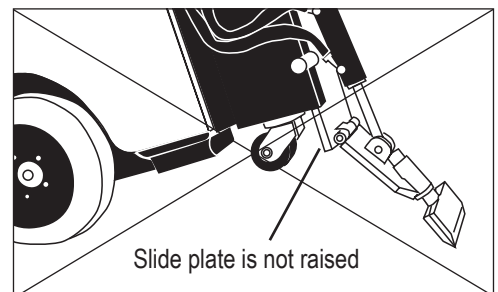

FIG. 19.1

Operation

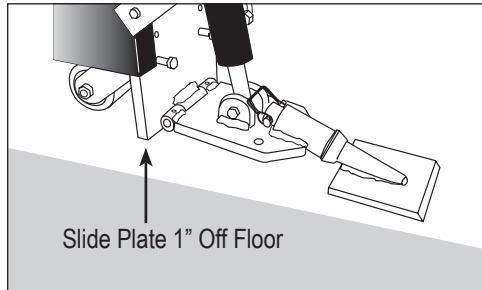

FIG. 20

APPLICATION SETUP

Ceramic (Figure 20)

The slide plate should be adjusted to a low setting 1" (2.5 cm) off the floor. Use a shank blade or a shank blade with a carbide tip.

Wood

The slide plate should be adjusted to a low setting 1" (2.5 cm) off the floor. Use shank blades, shank blades with carbide tips, or a 6" or 8" (15-20 cm) cutting head with heavy duty blades.

Note: Run machine 45° to the grain of the wood.

Secondary Backing Carpet

The slide plate should be adjusted to a low setting 1" (2.5 cm) off the floor. Use a cutting head from 10"-27" (25-68 cm) with heavy duty blades or a cutting head from 10"-14" (25-35 cm) with a self-scoring blade.

Foam Back Carpet

The slide plate should be adjusted to a low setting 1" (2.5 cm) off the floor. Use cutting heads from 10"-14" (25-35 cm) with self-scoring blades. If it is not stuck tight, use a cutting head from 14"-27" (35-68 cm) with a standard blade.

Double Stick Carpet

The slide plate should be adjusted to a low setting 1" (2.5 cm) off the floor. It is best to test to see which is the easiest way to remove double stick. Start with a cutting head from 10"-14" (25-35 cm) with self-scoring blades. Use self-scoring blades with 4" wings, 6" or 12" wide for best results. In some cases, carpet might pull off the pad and then scrape up the pad separately. Usually leaving carpet connected to the pad works the best.

Note: When removing carpet from over VCT tile and the tile needs to be saved, run the machine at a 45° angle over the tile. This should help to save the tile.

VCT Tile

The slide plate should be adjusted to a low setting 1" (2.5 cm) off the floor. If goods come up easily, change to a larger cutting head. If goods come up harder, use a cutting head from 6"-8" (15-20 cm) with a premium high-tempered blade (.062) to match cutting head size. Sometimes a .094 blade may work better. If goods remove easily, a tile box (#7074) can be used. A tile box also works for wind rowing, and assists for a fast clean-up and collection of tile debris for quick removal.

Rubber Tile

The slide plate should be adjusted to a low setting 1" (2.5 cm) off the floor. Use a cutting head from 6"-14" (15-35 cm) with self-scoring blades or use ditching method with a flat blade.

Re-Scraping

Slide plate should be set high, 6"-8" (15-20 cm) off the floor. Use a cutting head from 8"-27" (20-68 cm) with scraper blades to match cutting head size. A 15" (38 cm) scraper blade would use a 14" (34 cm) cutting head. Razor blades are faster but a cutting head from 8"-14" (20-35 cm) can be used with a standard blade. Flip head regularly.

Thin Coating and Glues

Slide plate could be set high, 6"-8" (15-20 cm) or low 1" (2.5 cm) off the floor. Test to see which works best. Use a cutting head from 8"-27" (20-68 cm) with razor blades to match cutting head size.

Concrete

Blade should be bevel up when working over concrete. Pretty much anything over concrete works. Try different setups to see which works best. If goods come up difficult, the slide plate should be at a low setting, 1" (2.5 cm) off the floor. Use a smaller size blade. If goods come up easily, a wider blade can be used.

Wood Sub-Floor

A heavy machine cannot be used on wood subfloors or raised panel computer floors. Keep machine light; remove all weights. A weighted machine could break through the floor. The slide plate should be adjusted to a low setting, 1" (2.5 cm) off the floor. Blades should be as flat of an angle as possible. Use a heavy duty blade (these blades have a bend to them) or a regular blade bevel down. When using a regular blade, bending up the corners of the blade will help from the blade digging into the floor. Sometimes a shank blade or a shank blade with a carbide tip will work. Allow blade to shear material from the floor. The trick on wood floors is to run the blade flat. Approach should be at a 45° angle to the board. This keeps from digging into the board and hanging up at the seams.

Soft Sub-Floor

The slide plate should be adjusted to a low setting 1" (2.5 cm) off the floor. Blades should be as flat of an angle as possible. Use a heavy duty blade (these blades have a bend to them) or a regular blade bevel down. When using a regular blade, bending up the corners of the blade will help from the blade digging into the floor. Sometimes a shank blade or a shank blade with a carbide tip will work.

DITCHING

Cross Room Ditching (Figure 21)

When removing hard to remove ceramic, VCT, or VAT, cross-room ditching will help to make the removal easier. Using a blade 2"-6" (5-15 cm) in width, make ditches 1'-2' (30-60 cm) apart in the same direction the machine will be removing the goods. This relieves the pressure holding the tiles together. If ditching helps and the goods are coming up easy, try using a wider blade to ditch with.

Checkerboard Ditching (Figure 22)

To make carpet removal and debris clean-up easier, checkerboard ditching is very helpful. Using as wide of a self-scoring blade as possible, make ditches 4'-6' (1.25-1.75 m) crossways from the way the machine will be removing the goods. Running the machine crossways from the ditches will make smaller pieces of debris to be hauled away. Instead of large gummy rolls of carpet, there are small squares that can be rolled, palletized, put on a dolly, or folded with the sticky side in. This makes removing the debris easier and reduces the amount of debris.

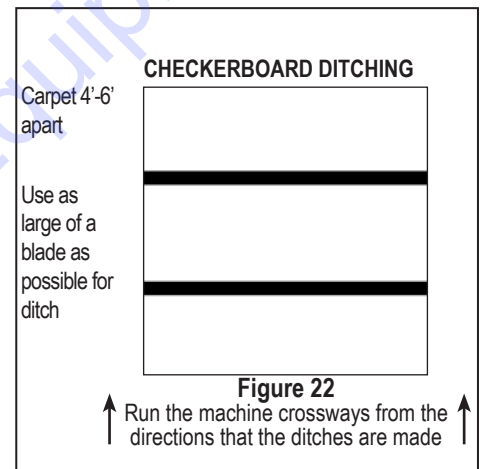
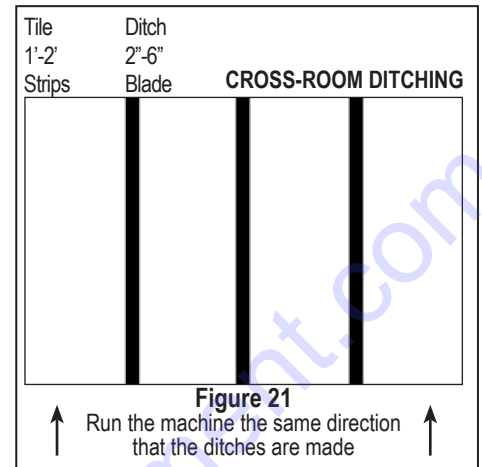

Maintenance Schedule

Maintenance to be performed	Interval					
	Daily	200 hrs	1000 hrs	2000 hrs	After initial 100 hrs	After initial 500 hrs
Inspect extension cord for damage	•					
Check wheels, caster and wheel motors for build up; and clean	•					
Inspect all safety devices (e-stop, backup beeper, seat switch)	•					
Inspects for leaks (hoses and fittings)	•					
Blow out fan cover on the bottom of the motor after each job	•					
Grease front caster wheel			•			
Check hydraulic oil level		•			•	
Replace the spin-on hydraulic oil filter		•			•	
Change hydraulic fluid			•			•

It is recommended to perform initial maintenance during the break-in period when first operating the machine. After the first 100 operating hours the hydraulic oil level should be checked and the spin-on hydraulic oil filter should be replaced, then every 200 hours thereafter. At the 500 operating hour mark the hydraulic fluid should be changed. Regular maintenance should be performed according to the schedule.



WARNING: THE BACK-UP BEEPER IS ON THE MACHINE FOR SAFETY. IT IS IMPORTANT TO KEEP IT IN GOOD WORKING CONDITION. FAILURE TO DO SO COULD CAUSE BODILY INJURY.

Troubleshooting Guide

Problem	Cause	Solution
Machine will not start.	Seat safety switch is disengaged.	Ensure operator is seated.
	Emergency stop (E-Stop) switch is disengaged.	Twist E-Stop so that it is in the "POWER ON" position.
	Circuit breaker is in the "OFF" position.	Verify circuit breaker is in "ON" position.
	48 volt blue plugs are not connected.	Make sure that connection plugs are fully installed.
	"Start" button did not fully engage.	Firmly press down green start button.
	Wire harness is disconnected.	Connect wire harness.
	Batteries are low.	Charge batteries.
Machine doesn't run as long as it used to.	Battery is not fully charging.	Verify that battery is being properly charged. Verify that charger is working properly. Charger has a LED light to indicate.
	The 48 volt blue plugs are not connected.	Check that connection plugs are fully installed.
	Batteries no longer hold a charge.	Call NFE for procedure.
	Motor fan cover plugged with dust or debris.	Blow out fan cover after each job.
Machine is making rattling noises.	Loose hardware on machine.	Inspect and tighten bolts as needed.
Charger is hot.	Charger is in use.	This is normal.
Fluid is leaking from machine.	Hose connections/or fittings have loosened through normal use.	Tighten hydraulic hoses and fittings as needed.
	Pin hole in the hoses.	Replace affected hose.
	Oil and/or oil filter are old.	Replace oil and oil filter yearly on machine.
Tires/Wheel motors make a slight clicking noise.		Normal noise with proper operation.
Machine is jerky or jumpy.	New operator.	Additional time is required to become familiar with machine.
	Control levers are being moved too quickly.	Operate control levers with wrist resting on knees for additional support or purchase arm rest.
Coupling leaks at thread or seat.	Missing or damaged O-rings.	Check for missing or damaged O-rings; replace if necessary.
	Damaged threads due to misalignment or improper seat angle.	Correct seat angle. Check for thread damage; replace if necessary.
	Over or under torquing.	Only hand tighten hardware.
Any issues not listed above.		Contact Discount-equipment.

Maintenance



WARNING: ALWAYS DISCONNECT BATTERY BEFORE PERFORMING MAINTENANCE.

MANUAL SLIDE PLATE REMOVAL



WARNING: SLIDE PLATE WILL DROP TO THE FLOOR WHEN SLIDE PLATE SECURING BOLTS ARE DISENGAGED. KEEP HANDS AND FEET OUT FROM UNDERNEATH SLIDE PLATE, FAILURE TO DO SO COULD CAUSE SEVERE BODILY INJURY.

1. Disconnect machine from power.
2. Remove slide plate pin.
3. Remove cutting head bolt
4. Remove cylinder from slide plate.
5. Remove slide plate.

OR

1. Disconnect machine from power.
2. Disconnect hydraulic lines from cylinder. A small amount of oil leak out of lines, place rag below line to catch fluid. Cap lines or bleed into a container. Wipe up spillage immediately.
3. With lines removed, loosen slide plate bolts. Hold slide plate at the top of the cylinder.
4. Remove slide plate, cylinder and lower cutting head support.

DUAL SLIDE PLATE REMOVAL



WARNING: ASSEMBLY IS VERY HEAVY. USE TEAM LIFT OR FORKLIFT TO LIFT. KEEP HANDS AND FEET OUT FROM UNDER THE ASSEMBLY. FAILURE TO DO SO COULD CAUSE SEVERE INJURY.

1. Lower the slide plate to the floor and place a wood block under the assembly.
2. Remove the front cylinder by taking the 1/2" bolt out of the bottom and removing the hitch clips and pin from the top of the cylinder.
3. Remove the E-clips from the pin at the bottom of the internal cylinder, then remove the pin.
4. Remove the pin from the top of the internal cylinder and then remove the cylinder from the machine.
5. Loosen the pinch bolt from the lower right side of the frame.
6. Remove the lock nut from securing bolts at the top of the slide plate.
7. Remove the socket head screws at the top of the dual slide from both sides of the assembly.
8. Install 3/8-16x5" bolts into the holes the socket head screws were removed from. Once installed the bolts should be used as lifting handles.
9. Lift the frame out of the machine.

LEAK MAINTENANCE

All fittings on this machine are O-ring style.

1. Disconnect machine from power.
2. If a leak is detected, tighten fitting with the proper wrench size. Do not over-tighten. Over-tightening could damage to O-rings.

CHECK HYDRAULIC OIL LEVEL

Check fluid level in the fill hole on the right side of the frame, in front of the rear wheel.

1. Remove filler plug.
2. Oil should be visible 1" below hole.
3. Reinsert plug.

HYDRAULIC OIL CHANGE OUT

1. Disconnect machine from power (charger or battery).
2. Drain fluid by removing the drain plug from side of tank. This unit contains 6 gallons (22.7 liters) of fluid. Ensure the container size is adequate to catch fluid.
3. Replace drain plug.
4. Remove filler plug.
5. Add oil into the fill hole. Total tank capacity is 6 gallons (22.7 liters). Due to a certain amount of retained oil, the oil change refill amount is 5.5 gallons (20.8 liters). *NOTE: Adding more than this amount could cause the oil to overflow from the vent tube.*

CHANGE HYDRAULIC CYLINDER

1. Disconnect machine from power.
2. Disconnect cylinder lines. Have a container ready to catch oil from lines.
3. Remove cylinder securing hexhead bolt from lower cutting head support.
4. Remove clips and pin from cylinder and slide plate.
5. Remove cylinder upper pin.
6. Remove cylinder.

CHANGE/REMOVE HOSE

1. Disconnect machine from power.
2. Remove hood.
3. Using proper wrench size, remove hose from fitting.
4. When replacing, make sure O-ring is properly seated on hose fitting.

CHANGE PUMP

1. Open hood to expose pump.
2. Disconnect hydraulic lines.
3. Remove two 5/16" pump securing bolts.
4. Remove pump by pulling pump straight out from pump motor.

CHANGE VALVE

1. Disconnect machine from power (charger or battery).
2. Lift hood all the way back, resting on the hood bumpers.
3. Remove hoses from valve body. Have a container ready to catch leakage from lines.

Maintenance

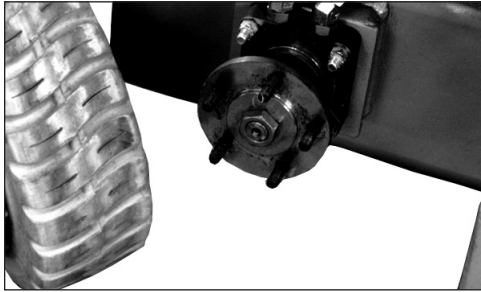

FIG. 1

4. Take notice of angle of valve fittings.
5. Remove two 5/16-18" bolts securing valve body.

CHANGE WHEEL MOTOR

1. Disconnect machine from power.
2. Block up machine to remove wheel.
3. Remove wheel.
4. Remove oil lines from wheel motor. A small amount of oil will run out of the lines. Drain into a container. Wipe up spills immediately.
5. Remove four 1/2" wheel motor securing nuts.
6. Pull out on wheel motor to remove.

CHANGE REAR WHEEL (FIG. 1)

1. Jack machine up by pushing the cylinder lift forward to lower and adjust the angle of the cutting head to raise machine.
2. Place blocks under forklift cups on the side of the machine that wheel is being changed.
3. Let cylinder down resting machine on blocks allowing rear wheel to be lifted off the floor.
4. Remove five 1/2" lug nuts with an extended arm wrench, remove wheel.
5. Replace wheel.
6. Replace five lug nuts and tighten, making sure lug nuts are very tight.
7. Raise cylinder to raise machine off of blocks. Remove blocks and lower machine.
8. Repeat on other side if necessary.

CHANGE CASTER

Keep clean and free of debris; ensure it can move freely.

1. Give a shot of grease in grease fitting on caster every month to keep caster moving freely.
2. To remove caster, machine will need to be raised. Push the cylinder lift lever forward to lower and adjust the angle of the cutting head to jack up the machine. Block up machine with wooden block. Remove four bolts, pull caster off and clean/replace as needed.
3. Replace caster.
4. Pull caster toward rear of machine; re-place and tighten the four bolts.
5. Lower the machine.

CHANGE MOTOR

1. Disconnect motor from power.
2. Lift hood and secure in place.
3. Remove pump.
4. Loosen screws and nuts.

5. Raise motor; disconnect electrical connections.
6. Remove and replace motor.

SEAT REPLACEMENT

1. Rotate hood to bumper stops.
2. Remove four nuts securing seat rails.
3. Replace seat; screw on nuts.

REMOVE/REPLACE FOOT PEG

1. Insert a socket wrench into foot peg and secure bolt head.
2. Remove nut.
3. Remove bolt and foot peg.
4. Replace foot peg before operating machine. Do not operate machine without foot pegs.

CLEAN WHEEL MOTOR BUILD-UP

1. Inspect the wheel motor and wheel motor hub for debris build-up (best accessed from back of machine). Remove any strands of carpet and use compressed air (not high pressure) to clean out dust or glue build-up. If any build-up cannot be removed this way, complete the following steps to remove the wheel hub.
2. Raise the front of the machine up by lowering the front cutting head down all the way, or by using 2 ton jack. Place blocks under the fork lift cup.
3. Slowly raise the cutting head until the machine is resting on the blocks and the wheel on the side that is blocked up is raised off the ground.
4. Remove the cotter pin and loosen the center wheel hub nut.
5. To loosen the wheel from the wheel motor shaft you might need to hit the steel rim from the inside with a rubber mallet.
6. Remove the wheel and remove the build up off of the wheel motor shaft.
7. Re-mount the wheel hub, making sure that the keyway matches on the motor shaft. Tighten down the wheel hub nut to press fit in the wheel hub.
8. Re-insert the cotter pin.
9. Lower the cutting head to raise the machine back off the blocks.
10. Repeat the process for the opposite side if needed.

Parts List and Diagrams

EXTERNAL



Item No.	Part No.	Description	Qty.
1	5200QL-25-SV	Panel, Right, Silver Vein (2900-10XXXX, -17XXXX)	1
	5200QL-25-BLK	Panel, Right, Black (2900-30XXXX)	1
2*	5200QL-26-SV	Panel, Left, Silver Vein (2900-10XXXX, -17XXXX)	1
	5200QL-26-BLK	Panel, Left, Black (2900-30XXXX)	1
3*	5200QL-27	Base, Main	1
4	5200QL-28-SV	Cover, Battery, Silver Vein (2900-10XXXX, -17XXXX)	1
	5200QL-28-BLK	Cover, Battery, Black (2900-30XXXX)	1
5	403131-SV	Cover, Hinged Top, Silver Vein (2900-10XXXX, -17XXXX)	1
	406357-BLK	Cover, Hinged Top, Beacon/Seat Belt, Black (2900-30XXXX)	1
6	5200-30-SV	Doghouse, Weldment, Silver Vein (2900-10XXXX, -17XXXX)	1
	405487-BLK	Doghouse, Worklight, Black (2900-30XXXX)	1
7	5200-603	Guide, Hose	1
8*	2900-101	Hold Down, Rear	1
9*	2900-102	Latch, Rear	1
10	NA	See Charger Assembly	1

*Not shown

Parts List and Diagrams

CASTER WHEEL ASSEMBLY

Item No.	Part No.	Description	Qty.
1	402280	Caster Assy, Kingpinless, 4", Plate-Mount	1
1.1*	403352	Wheel, 4"OD x 2-1/2"W (Wheel Only)	1
1.2*	403353	Axle, Including Nut	1
2	73403	Washer, Lock, 1/2	4
3	73406	Screw, Hex Head Cap, 1/2-13x1-1/4	4
4	73424	Washer, Flat, Zinc SAE 1/2	4

*Items 1.1 and 1.2 are included as part of Item 1 and are also available individually.

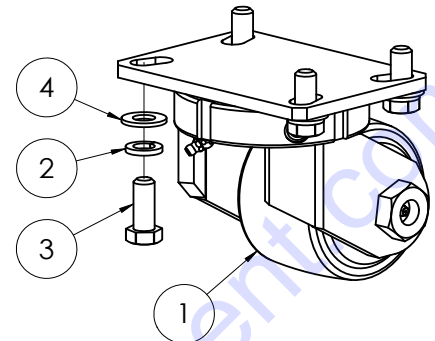

REAR WHEEL ASSEMBLY

ITEM NO.	PART NUMBER	DESCRIPTION	QTY.
1	400133	Motor, Wheel, Hydraulic, 10mm	1
2	73047	1/4 x 1 Woodruff Key	1
3	73402	Nut, Nylock 1/2-13	4
4	5110-117	Wheel, Hub	1
5	73430	Nut, NyLock 1/2-20	5
6	5110-405	Wheel, Rim and Tire, 18"	1
7	5110-117-2	Hub Nut	1
8	401433	Pin, Cotter 1/8 x 1.75	1

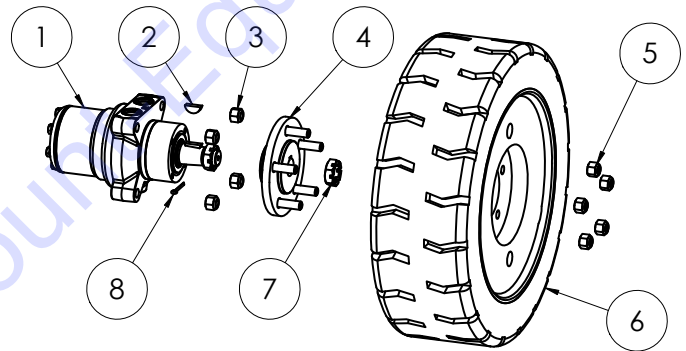

PART#	DESCRIPTION	QTY
1	73014 1/4-20 X 1-1/2 HEXHEAD BOLT	1
2	5200QL-31 HOOD LEVER ONLY	1
3	73008 1/4-20 NYLON LOCK NUT	4
4	5200QL-34 REVERSE CATCH	1
5	73005 1/4-20 X 1/2 HEXHEAD BOLT	3
6	73007 1/4 FLAT WASHER	3

HOOD LEVER

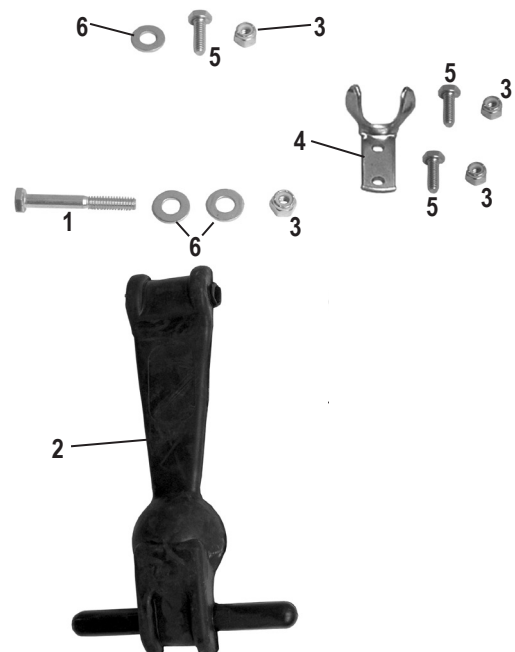

Parts List and Diagrams

BACKUP BEEPER ASSEMBLY



	PART#	DESCRIPTION	QTY
1	5200-116	BACK-UP BEEPER ASSEMBLY	1
2	73020	BOLT, WIZLOCK 1/4-20X5/8	2

INSTRUCTION TUBE

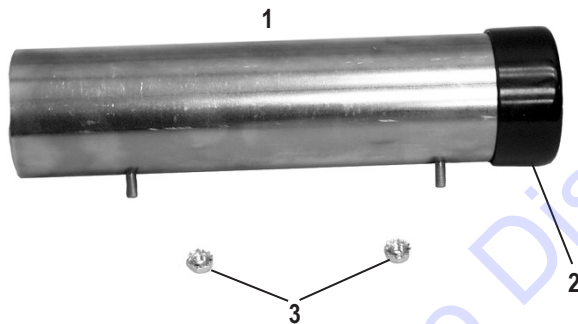

	PART#	DESCRIPTION	QTY
1	70602	TUBE, INSTRUCTION MANUAL	1
2	70603	CAP, INSTRUCTION TUBE	1
3	74425	NUT, KEPS LOCK 10-32	2

SEAT ASSEMBLY



	PART#	DESCRIPTION	QTY
1	5110-111	SEAT, RIDE-ON	1
2	400321	ARM RESTS, KIT FOR SEAT	1
3	402969	BOLT, TRILOBULAR, 5/16-18 X 1.25, FLANGED HEX HEAD (NOT SHOWN)	4
4	5110-207	SWITCH, SEAT	1
5	403137	HARNESS, SEAT, 2900 (NOT SHOWN)	1

Parts List and Diagrams

ELECTRIC BOX & BATTERY CONNECTOR

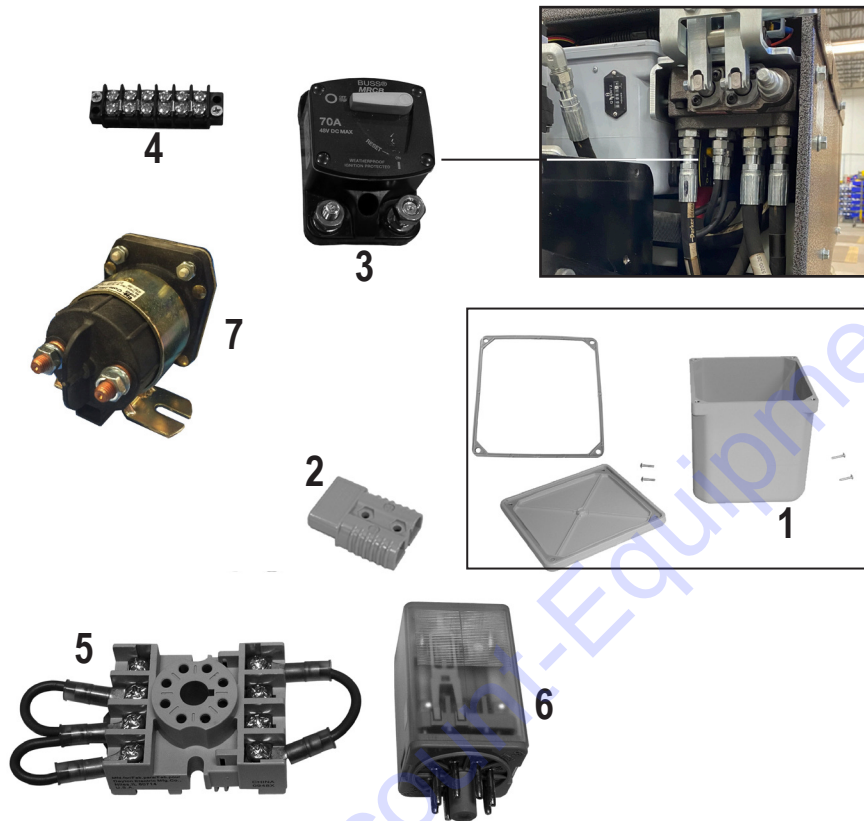

PART#	DESCRIPTION	QTY	PART#	DESCRIPTION	QTY		
1	5200-118-1A	BOX, ELECTRICAL, ONLY	1	5	5700-90	RELAY, SOCKET	1
2	5200-118-9	CONTACTS, TERMINAL, SB175 SERIES	2	6	5700-91	RELAY	1
3	5700-106	BREAKER, CIRCUIT, 70 AMP	1	7	5700-104	SOLENOID	1
4	5200-127	TERMINAL, STRIP	1				

PARTS NOT SHOWN

PART#	DESCRIPTION	QTY	PART#	DESCRIPTION	QTY		
1	400206	WIRE, PRIMARY, 16 GPT-500-BLK	1	15	74761	GROMMET, RUBBER 3/8"	1
2	400207	WIRE, PRIMARY, 16 GA, RED, GPT SERIES	1	16	402886	PROBE, THERMAL	1
3	5700-88	METER, HOUR	1	17	403245	SEAL, CABLE, 16 GA, METRI-PACK 150	12
4	70610	LOOM, CORROGATED, SLIT, BLACK, .250 ID	6	18	403246	TERMINAL, FEMALE, 18-16 GA, METRI-PACK 150	12
5	71703	PROTECTOR, BATTERY TERMINAL, RED	2	19	403247	LOCK, FEMALE, 4 POSITION, METRI-PACK 150	1
6	72580	WIRE, PRIMARY, 16 GPT-500-BLU (TSC)	4.3	20	403248	LOCK, FEMALE, 8 POSITION, METRI-PACK 150	1
7	72581	WIRE, STRANDED, 16 GAUGE, WR16-9	4.3	21	403249	CONNECTOR, FEMALE, 8 POSITION, METRI-PACK 150	1
8	72761	TERMINAL, END, BATTERY 4	4	22	403250	CONNECTOR, FEMALE, 4 POSITION, METRI-PACK 150	1
9	72765	TERMINAL, END, NYLON, 12-10	2	23	403256	TERMINAL, RING, 16-14 GA, 3/8" STUD, NYLON INSULATED	2
10	72778	TERMINAL, 16-14 GAUGE, NYLON, B RING	20	24	400254	WIRE, PRIMARY, 16 GPT-500-YEL	30
11	72815	TERMINAL CONNECTOR, FEMALE, PUSH-ON	2				
12	72821	TERMINAL, RING, 16-14 GAUGE, NYLON, 10 STUD	8				
13	72835	HOUSING, CONTACT, BLUE	1				
14	73504	STRAIN RELIEF, STRAIGHT 3/4 INCH .750"-1.00	3				

Parts List and Diagrams

CHARGER ASSEMBLY

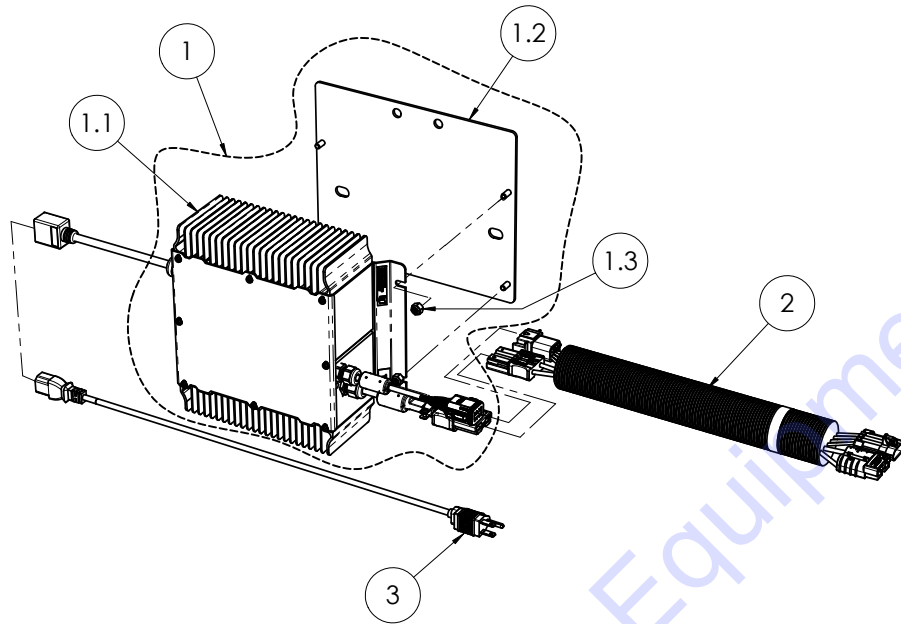

Item No.	2900-10XXXX 2900-17XXXX	2900-30XXXX	Description	Qty.
1	403203		Assembly, Delta-Q Charger Replacement, 1500W, 108-250VAC, Hi-Freq, 160-220AH	1
		406653	Assembly, Delta-Q Charger Replacement, 1000W, 85-265VAC, Hi-Freq, 160-220AH	1
1.1	406470		Assembly, Charger, Battery, 1500W, 108-250VAC, Hi-Freq, 160-200AH	1
		406471	Assembly, Charger, Battery, 1000W, 85-265VAC, Hi-Freq, 160-220AH	1
1.2	402588	402588	Plate, Mounting, High Frequency Charger	1
1.3	73008	73008	Nut, Hex, Nylon Insert, 1/4-20	4
2	403146	403146	Harness, Charger	1
3	402878		Cord, Power, SJTO, 14/3, NEMA 5-15 TO C-13, 2ft	1
		403782	Assembly, Cord, NEMA 5-15 Style, Folding Ground, 7ft	1

CHARGER GUARD (2900-30XXXX ONLY)

Item No.	Part Number	Description	Qty.
1	402577	Guard, Charger	1
2	73020	Bolt, Wizlock, 1/4-20x5/8	2

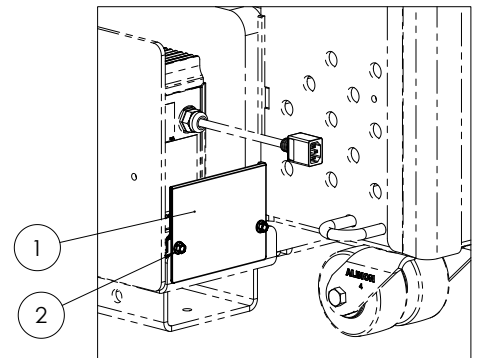

Parts List and Diagrams

SPOOL AND HOSE (DUAL LIFT)

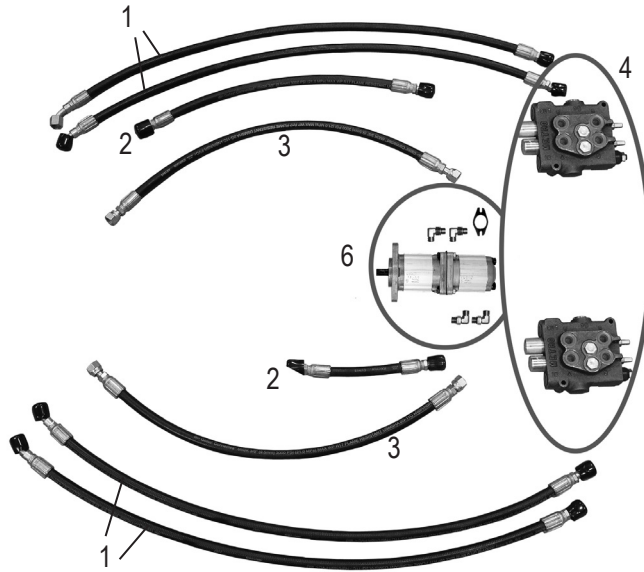

SPOOL AND HOSE (MANUAL LIFT)

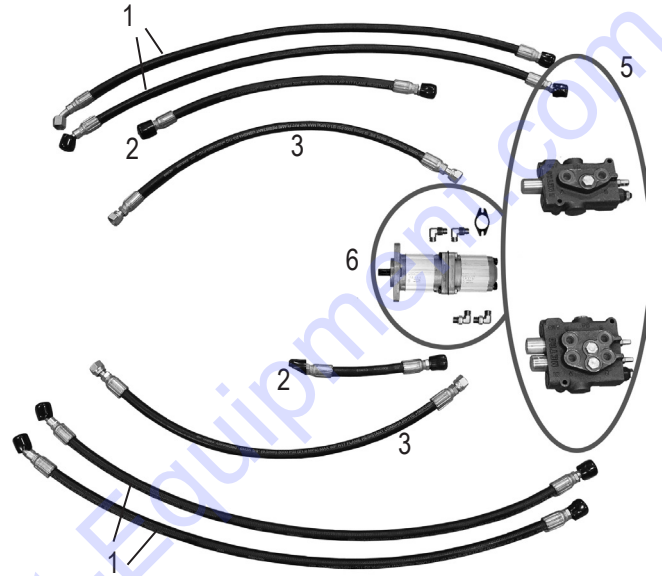

PART#	DESCRIPTION	QTY	PART#	DESCRIPTION	QTY
1	5200-261 HOSE, WHEEL MOTOR	4	9	5700-77 SUCTION HOSE ASSEMBLY (NOT SHOWN)	1
2	5700-72 HOSE, HYDRAULIC, 3/8 X 26, F/F	2	10	5700-81 SUCTION LINE (NOT SHOWN)	1
3	5700-76 HOSE, HYDRAULIC, 3/8 X 21, F/F	2	11	5110-157 PLUG, DRAIN-FILLER (NOT SHOWN)	2
4	SEE CONTROL LEVER (DUAL LIFT) PARTS		12	6280-162G MAGNET, TANK (NOT SHOWN)	2
5	SEE CONTROL LEVER (MANUAL LIFT) PARTS		13	401635 HOSE, HYDRAULIC, 3/4 X 29, F/90F (NOT SHOWN)	1
6	SEE GEAR PUMP ASSEMBLY		14	70351 HOSE, HYDRAULIC, 3/8 X 10, F/90F (NOT SHOWN)	1
7	5110-114-2 WHEEL MOTOR FITTING	4			
8	5700-70 T-FITTING (NOT SHOWN)	1			

Parts List and Diagrams

MOTOR

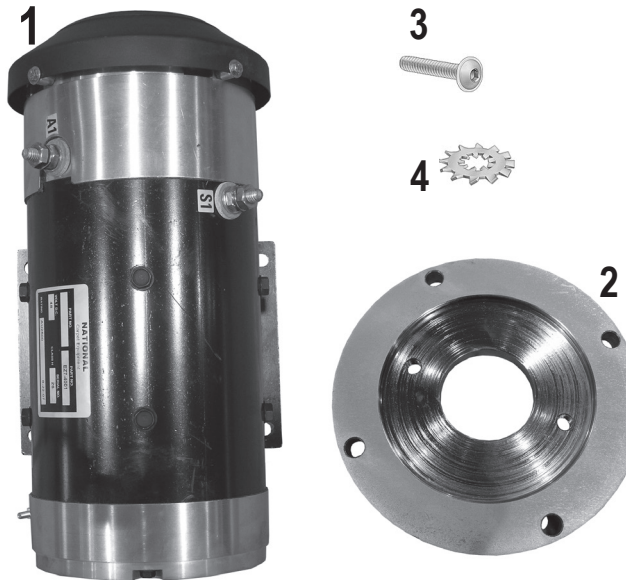

	PART#	DESCRIPTION	QTY
1	72385	4 HP MOTOR	1
2	5200QL-1A	MOTOR PLATE	1
3	73242	SCREW, BUTTON HEAD CAP WITH FLANGE 3/8-16 X 1	4
4	73210	WASHER, INTERNAL/EXTERNAL LOCK 3/8	4
5	73207	NUT, NYLOCK 3/8-16 (NOT SHOWN)	4

GEAR PUMP ASSEMBLY

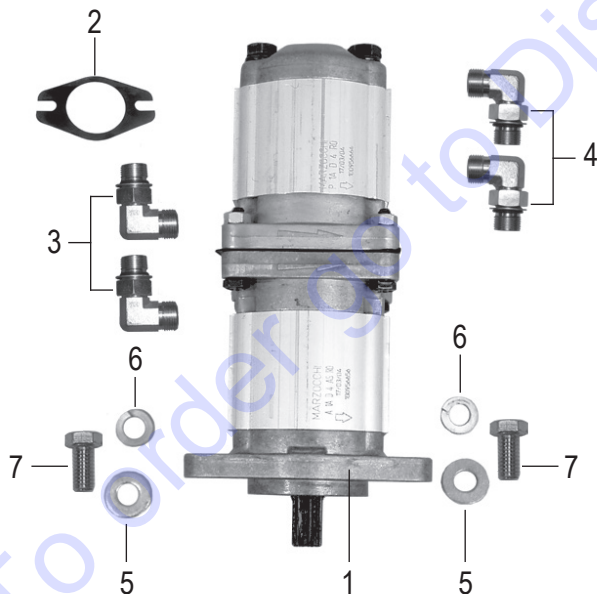

	PART#	DESCRIPTION	QTY
1	70905-D5	PUMP, DOUBLE, MARZOCCHI	1
2	5200-1G	GASKET, PUMP	1
3	72816	FITTING, ELBOW, 90 DEGREE, 3/8"	2
4	6280-118	FITTING, SUCTION HOSE TO PUMP	2
5	73263	WASHER, FLAT SEA ZINC 3/8	2
6	73204	WASHER, SPLIT LOCK 3/8	2
7	403626	SCREW, FERRY CAP, 3/8-16 X 3/4", 12PT	2

Parts List and Diagrams

SUCTION ASSEMBLY & FILTER

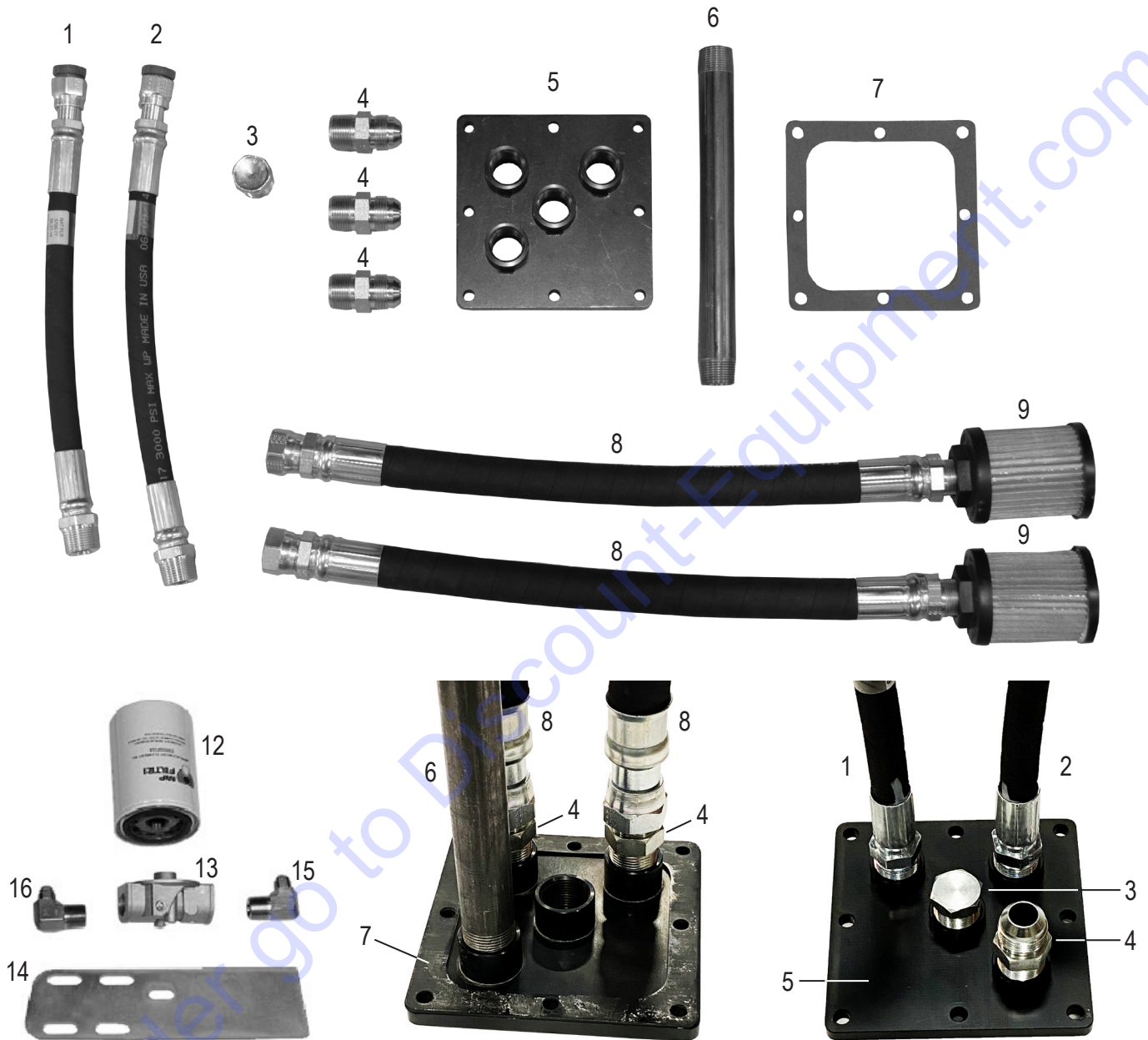

PART#	DESCRIPTION	QTY	PART#	DESCRIPTION	QTY
1	5700-77 ASSEMBLY, HOSE	1	9	5110-237 FILTER, SCREEN	2
2	5700-81 HOSE, SUCTION LINE	1	10	73310 SCREW, SHC, 5/16-18 X 7/8 (NOT SHOWN)	8
3	5700-67 PLUG, TANK	1	11	73303 WASHER, SPLIT LOCK, 5/16 (NOT SHOWN)	8
4	70652 FITTING	3	12	5700-65 FILTER	1
5	401574 PLATE, SUCTION	1	13	5700-66 HEAD	1
6	70655 PIPE, MALE, 10" X 3/4	1	14	70612 BRACKET	1
7	5700-93 GASKET	1	15	5700-64 FITTING, FILTER	1
8	400099 HOSE, SUCTION, 1/2" X 20" W/ FITTING	2	16	70653 FITTING, 90 DEGREE	1

Parts List and Diagrams

CONTROL LEVER (DUAL LIFT)

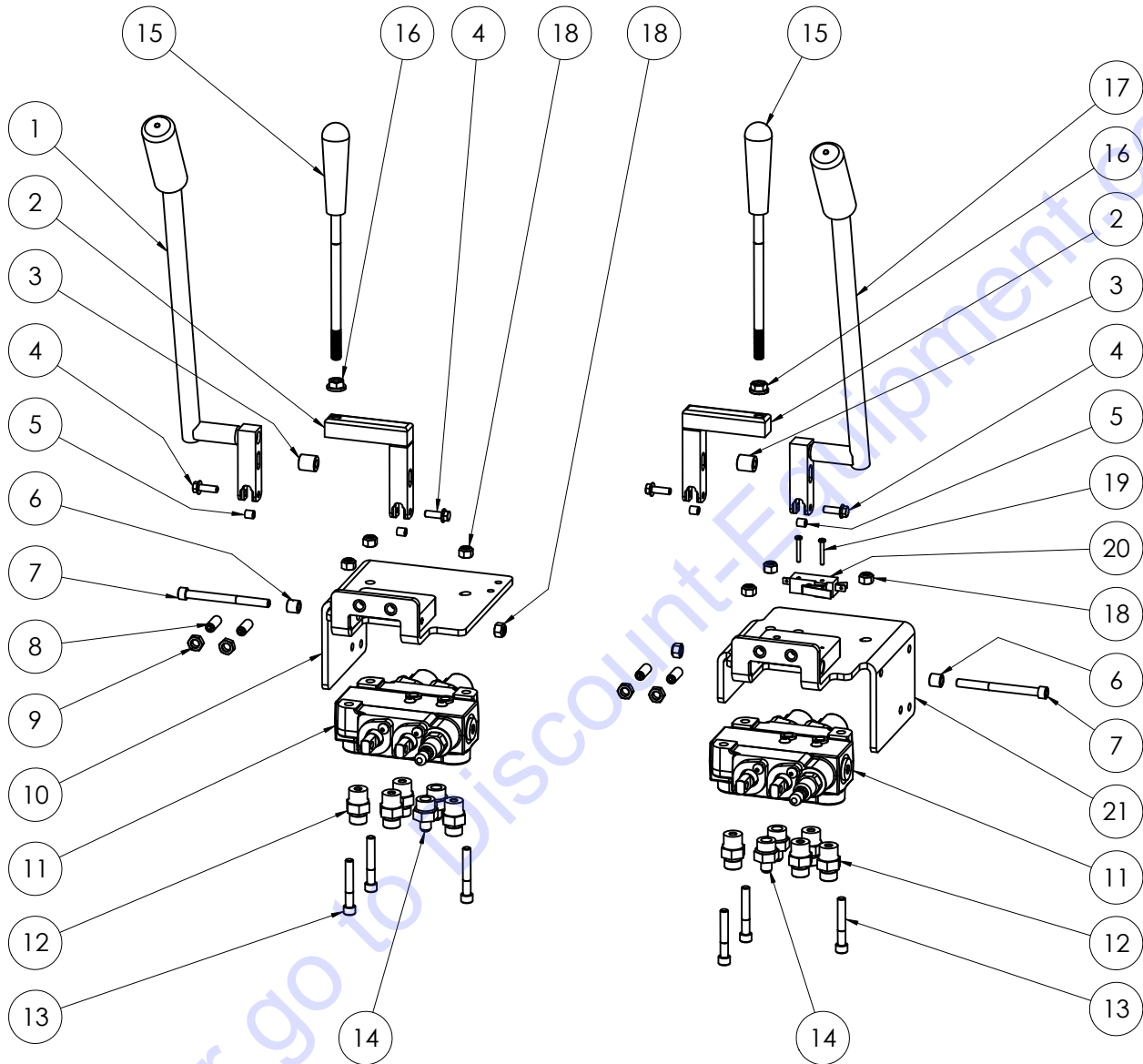

ITEM NO.	PART NUMBER	DESCRIPTION	QTY.	ITEM NO.	PART NUMBER	DESCRIPTION	QTY.
1	402416	Assembly, Valve Handle, Right	1	12	400034	Fitting, FF1231-06-08	8
2	401797	Bracket, Universal, Lever	2	13	73320	Bolt, Socket Head Cap 5/16-18x2	6
3	401408	Spacer, Round, .323 X .625 X .675	2	14	400137	Fitting, 1/2 - 1/4, JIC	4
4	73027	Bolt, Wizlock, 1/4-20 X 3/4	4	15	5700-60	Handle, Valve Adjustment	2
5	401604	Bushing, Lever, Hydro Valve	4	16	73211	Nut, Flange, Serrated, 3/8-16	2
6	402227	Sleeve, Take-up, Valve Brkt	2	17	402415	Assembly, Valve Handle, Left	1
7	73321	Bolt, SHCS, 5/16-18x3.5	2	18	73322	Nut, Nyloc, 5/16-18	8
8	73227	Screw, Set 3/8-24x1	4	19	74517	Screw, PPH-MS, 6-32x1	2
9	73235	Nut, Hex Jam 3/8-24	4	20	5110-218	Switch, Back-up Beeper	1
10	401796	Bracket Wldt, Valve, RH	1	21	401795	Bracket Wldt, Valve, LH	1
11	401832	Valve, Metered, Dual Spool, Low PSI	2				

Parts List and Diagrams

CONTROL LEVER (MANUAL LIFT)

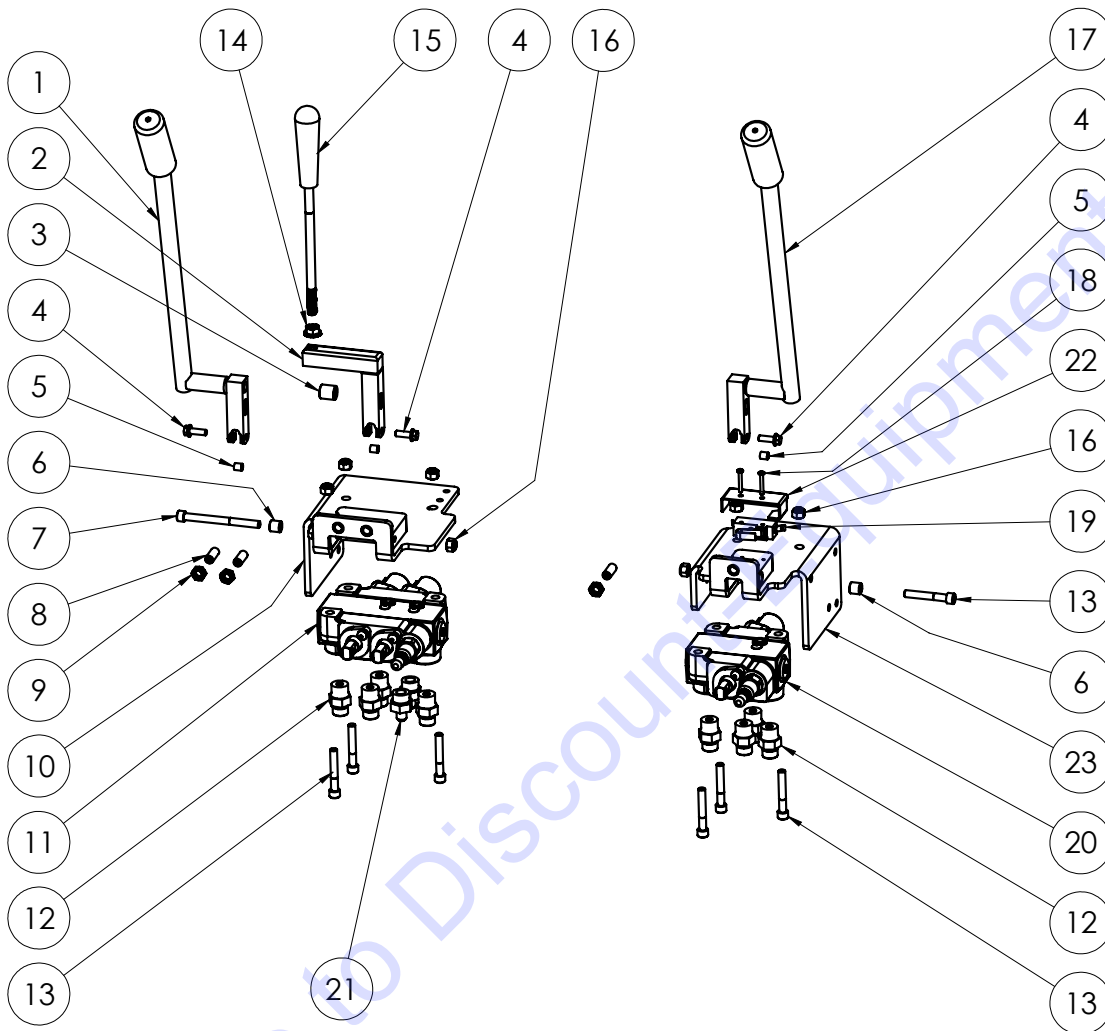

ITEM NO.	PART NUMBER	DESCRIPTION	QTY.
1	402416	Assembly, Valve Handle, Right	1
2	401797	Bracket, Universal, Lever	1
3	401408	Spacer, Round, .323 X .625 X .675	1
4	73027	Bolt, Wizlock, 1/4-20 X 3/4	3
5	401604	Bushing, Lever, Hydro Valve	3
6	402227	Sleeve, Take-up, Valve Brkt	2
7	73321	Bolt, SHCS, 5/16-18x3.5	1
8	73227	Screw, Set 3/8-24x1	3
9	73235	Nut, Hex Jam 3/8-24	3
10	401796	Bracket Wldt, Valve, RH	1
11	401832	Valve, Metered, Dual Spool, Low PSI	1

ITEM NO.	PART NUMBER	DESCRIPTION	QTY.
12	400034	Fitting, FF1231-06-08	8
13	73320	Bolt, Socket Head Cap 5/16-18x2	7
14	73211	Nut, Flange, Serrated, 3/8-16	1
15	5700-60	Handle, Valve Adjustment	1
16	73322	Nut, Nyloc, 5/16-18	8
17	402415	Assembly, Valve Handle, Left	1
18	74517	Screw, PPH-MS, 6-32x1	2
19	403064	Switch, Back-up Beeper	1
20	401833	Valve, Metered, Single Spool, Low PSI	1
21	400137	Fitting, 1/2 - 1/4, JIC	2
22	402949	Cover, Switch, Back-Up	1
23	402253	Bracket Wldt, Valve, Single, LH	1

Parts List and Diagrams

DUAL SLIDE PLATE

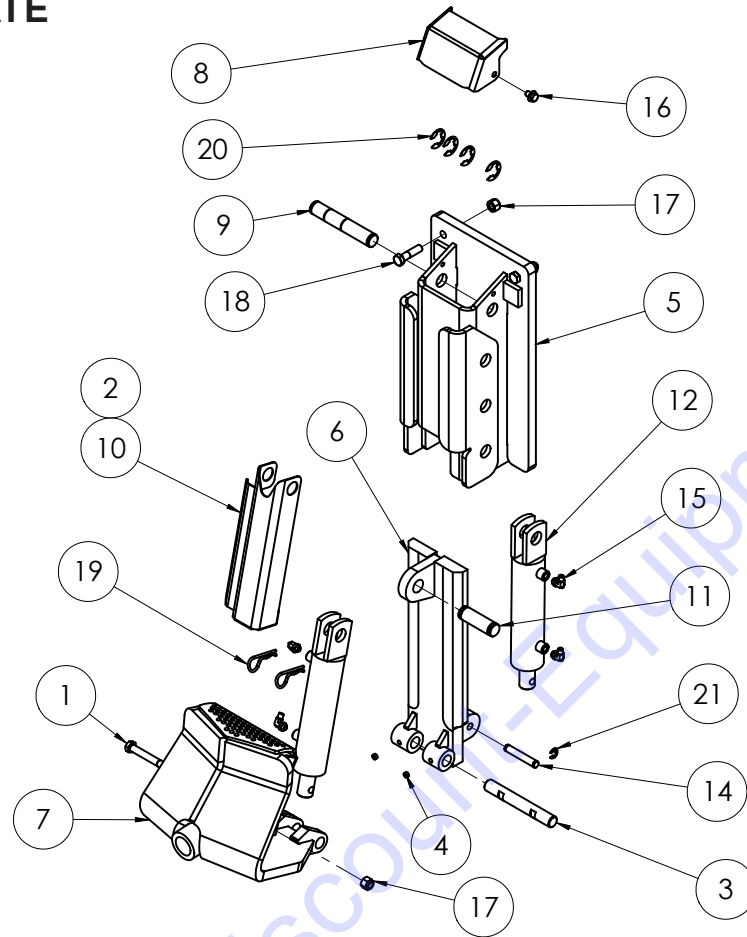

ITEM NO.	PART NO.	DESCRIPTION	QTY.
1	400132	Bolt, Hex Head, 1/2-13 x 4, Grade 8	1
2*	400296	Gasket, EPDM Foam	1
3	401429	Pin, Lower Cutting Head Support	1
4	401876	SSS, 3/8-24 x .25, Black Oxide	2
5	402423	Housing, Hydraulic Adjustment, Wldt	1
6	402432	Slide Plate, Hydraulic Adjustment, Wldt	1
7	402440	Tooling Holder, Weldment	1
8	402513	Cover, Hydraulic Adjustment, Housing	1
9	402542	Pin, Upper, Hydraulic Cylinder	1
10	402574	Shield, Cylinder	1
11	402576	Pin, Cylinder/Guard, Upper	1
12	5110-250	Cylinder NN16	2
13*	5110-267	Hose, Assembly, Hydraulic, 1/8 x 31.75, F/F	2
14	6500-31	Pin Lower Middle	1
15	72801	Fitting, 90 Deg., 1/4"	4
16	73224	Bolt, Wizlock, 3/8-16x1/2	2
17	73402	Nut, Nylock, 1/2-13	3
18	73413	Bolt, Hex Head 1/2-13x2	2
19	73536	5/8 Hitch Pin Clip	2
20	80083	E-Clip, 1" shaft	4
21	80084	E-Clip, 1/2" shaft	2

*Not shown

Parts List and Diagrams

MANUAL SLIDE PLATE

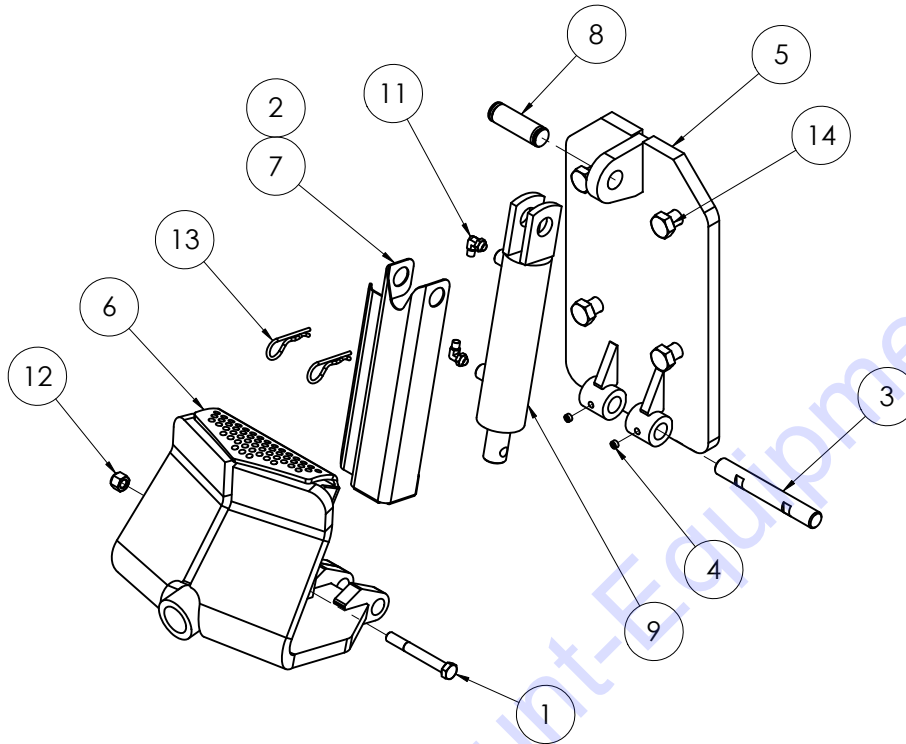

ITEM NO.	PART NO.	DESCRIPTION	QTY.
1	400132	Bolt, Hex Head, 1/2-13 x 4, Grade 8	1
2*	400296	Gasket, EPDM Foam	1
3	401429	Pin, Lower Cutting Head Support	1
4	401876	SSS, 3/8-24 x .25, Black Oxide	2
5	402410	Slide Plate, Steel, Manual Adjustment	1
6	402440	Tooling Holder, Weldment	1
7	402574	Shield, Cylinder	1
8	402576	Pin, Cylinder/Guard, Upper	1
9	5110-250	Cylinder NN16	1
10*	5110-267	Hose, Assembly, Hydraulic, 1/8 x 31.75, F/F	1
11	72801	Fitting, 90 Deg., 1/4"	2
12	73402	Nut, Nylock, 1/2-13	1
13	73536	5/8 Hitch Pin Clip	2
14	73605	Bolt, Hex Head, Grade 8, 3/4-10x1-1/2	4

*Not shown

Parts List and Diagrams

BREATHER DIP STICK

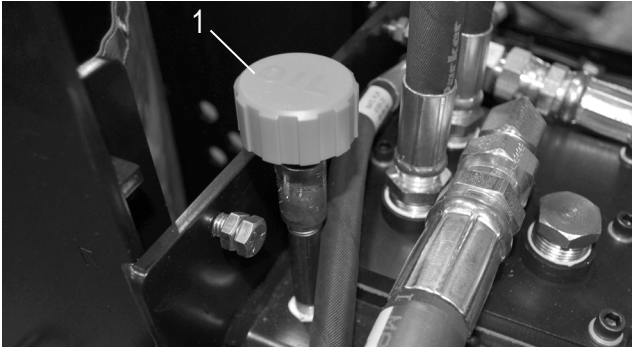

PART#	DESCRIPTION	QTY
1 405291	BREATHER CAP, WITH SPLASH GUARD, 1/4 NPT	1
2 402989	PIPE, RELIEF VALVE, 2-1/2"	1
3 5110-234	COUPLER, RELIEF VALVE	1
4 70655	PIPE, MALE, 10" X 3/4"	1

HOSE CLAMP ASSEMBLY

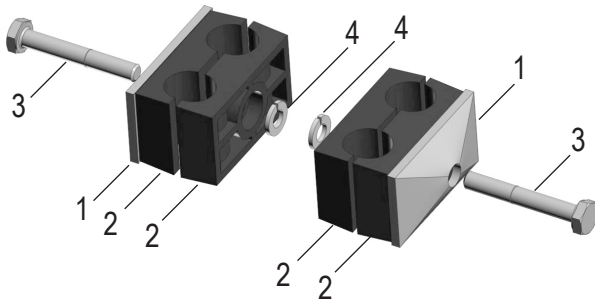

PART#	DESCRIPTION	QTY
1 5200-261-1A	CLAMP	2
2 5200-261-1B	BODY ONLY, CLAMP	4
3 73063	BOLT, HEX HEAD CAP 1/4-20X1-3/4	2
4 73002	WASHER, SPLIT LOCK 1/4	2

FOOT PEGS

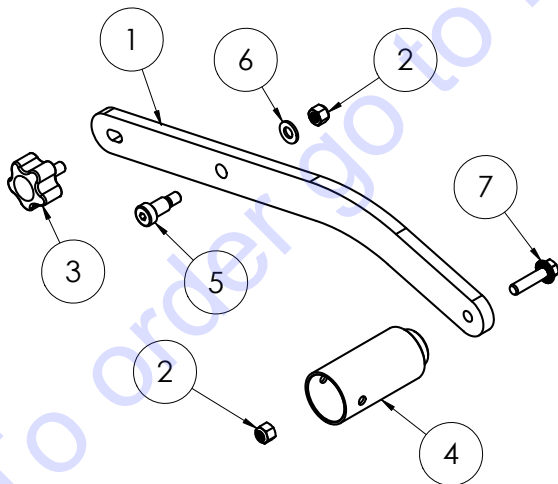

ITEM NO.	PART NUMBER	DESCRIPTION	QTY.
1	402298	Bracket, Pivot, Footrest	1
2	73207	NUT, NYLOCK, 3/8-16	2
3	401999	Knob, Adjustable, 3/4"	1
4	5110-180	Peg, Foot	1
5	402460	Bolt, Shoulder, .500 x .75, 3/8-16	1
6	73263	WASHER, FLAT SAE ZINC 3/8	1
7	73238	Bolt, Flange 3/8-16x1-1/2	1

Parts List and Diagrams

Item#	Part#	Description	Qty
1	5700-103	Switch, Start, Assembly (2900-10XXXX, -17XXXX)	1
1.1	72451*	Contact Block, NO, 10A, Spring Clamp, ZB4 Series	1
1.2	72454	Switch, Start	1
1.3	72456*	Collar, Mounting, 22mm, ZB4 Series	1
2	401415	Assembly, Keyed Switch (2900-30XXXX)	1
2.1	72451*	Contact Block, NO, 10A, Spring Clamp, ZB4 Series	1
2.2	72455	Switch, Keyed	1
2.3	72456*	Collar, Mounting, 22mm, ZB4 Series	1

*Not shown

STARTING CONTROLS

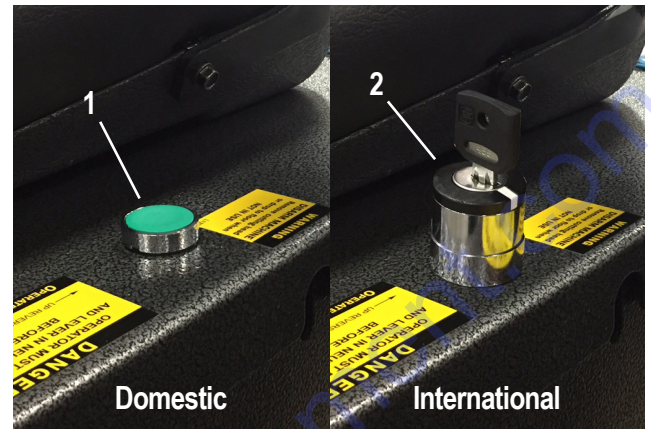

Item#	Part#	Description	Qty
1	5700-102	Assembly, E-Stop (2900-10XXXX, -17XXXX)	1
1.1	72452*	Contact Block, NC, 10A, Spring Clamp, ZB4 Series	2
1.2	72453	Switch, 22mm, E-Stop, ZB4 Series	1
1.3	72456*	Collar, Mounting, 22mm, ZB4 Series	1
1.4	5700-102D	Label, Emergency Stop	1
2	5700-102-JA	Assembly, E-Stop, Japanese (2900-30XXXX)	1
2.1	72452*	Contact Block, NC, 10A, Spring Clamp, ZB4 Series	2
2.2	72453	Switch, 22mm, E-Stop, ZB4 Series	1
2.3	72456*	Collar, Mounting, 22mm, ZB4 Series	1
2.4	5700-102D-JA	Label, Emergency Stop, Japanese	1
3	403042	Alarm, Low Voltage	1
4	74567	Screw, Phillips Pan Head, 8-32x3/8, Zinc-Plated	2

*Not shown

EMERGENCY STOP AND LOW VOLTAGE ALARM



Item#	Part#	Description	Qty
1	5700-88	Meter, Hour	1

Note: Some parts not shown for clarity.

HOUR METER



Parts List and Diagrams

BATTERIES



	PART#	DESCRIPTION	QTY
1	5200-28	SIDE SUPPORT ROD	2
2	5213-2	8 VOLT BATTERY, 180 AH	6
3	5700-62	COVER, BATTERY HOLD DOWN	2
4	5700-56	SPACER, BATTERY	9
5	5200-27	GUIDE, HOOD	2

FRONT WHEEL ASSEMBLY



	PART#	DESCRIPTION	QTY
1	5110-100	TRANSPORT WHEELS	1
2	5110-100W	CASTER ASSY, 5", TRANSPORT WHEEL	2

WEIGHTS

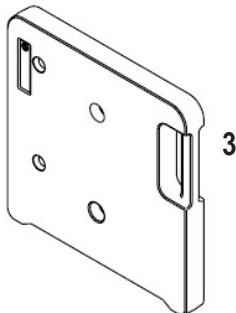

	PART#	DESCRIPTION	QTY
1	5110-404	WEIGHT, REAR	1
2	73406*	SCREW, HEX HEAD CAP, 1/2-13X1-1/4	1
3	74854	WEIGHT, POCKET, CAST, RIDE-ON	5
4	73403*	WASHER, LOCK, 1/2	8
5	73531*	WASHER, .656" X 1.312" X .095", STEEL	2
6	73424*	WASHER, FLAT, ZINC SAE 1/2	2
7	73414*	SCREW, HEX HEAD CAP, 1/2-13X7	2

*NOT SHOWN

Parts List and Diagrams

LABELS



Item	Part No.	Description	Qty.
1	406358-XX**	Kit, Label, Complete, 2900	1
2	L08-1	Label, Stand Clear	2
3	L33B	Label, Caution Moving Part	1
4	L137	Label, Disarm Machine	3
5*	L38	Label, Disconnect Power	2
6	L66	Label, Large Caution	1
7	L95F	Label, Fluid Leak	2
8	L106	Label, Pinch Point	2
9	L118	Label, Operator Must Be Seated	2
10	L142	Label, Trailer Hitch	1
11	L155	Label, General Warning	1
12	L98	Label, Blade Lift	2
13	402464	Label, National Logo, 5.5 x 6	2
14	402015	Label, 2900 Logo	2
15*	L223	Label, Patent	1

Item	Part No.	Description	Qty.
16	402149	Label, Forklift Point	2
17	L33C	Label, Instruction Manual	1
18	402376	Label, Ride-On Lift (2900-10XXXX, -17XXXX Only)	1
19	402462	Label, National Logo, 3 x 3	1
20*	L309	Label, "A"	6
21*	L311-2	Label, Battery	6
22	5700-102D	Label, Emergency Stop	1
23	L305	Label, Do Not Get Charger Wet	1
24	402926	Label, Charger, QuiQ1500 (2900-10XXXX, -17XXXX)	1
	402927	Label, Charger, QuiQ 1000 (2900-30XXXX)	1
25*	406360-JA	Label, CE, 2900, 100V, 50/60Hz, Japanese (2900-30XXXX Only)	1

*Not shown

**Kit includes Items 2-24. Suffix (-XX) denotes language: None=English; -JA=Japanese.

Wiring Diagrams

MAIN WIRING DIAGRAM

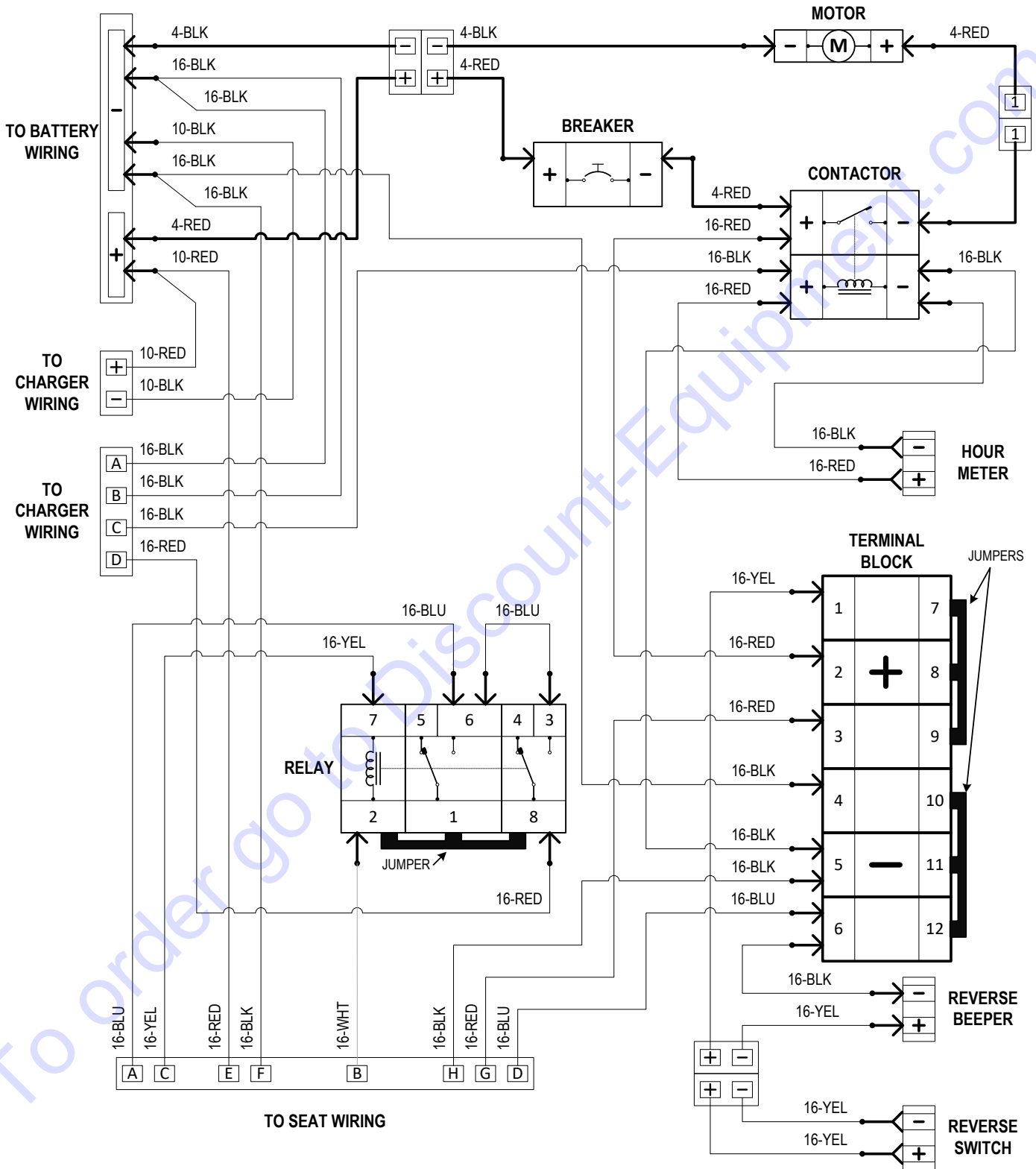

Wiring Diagrams

SEAT WIRING DIAGRAM

TO BODY WIRING

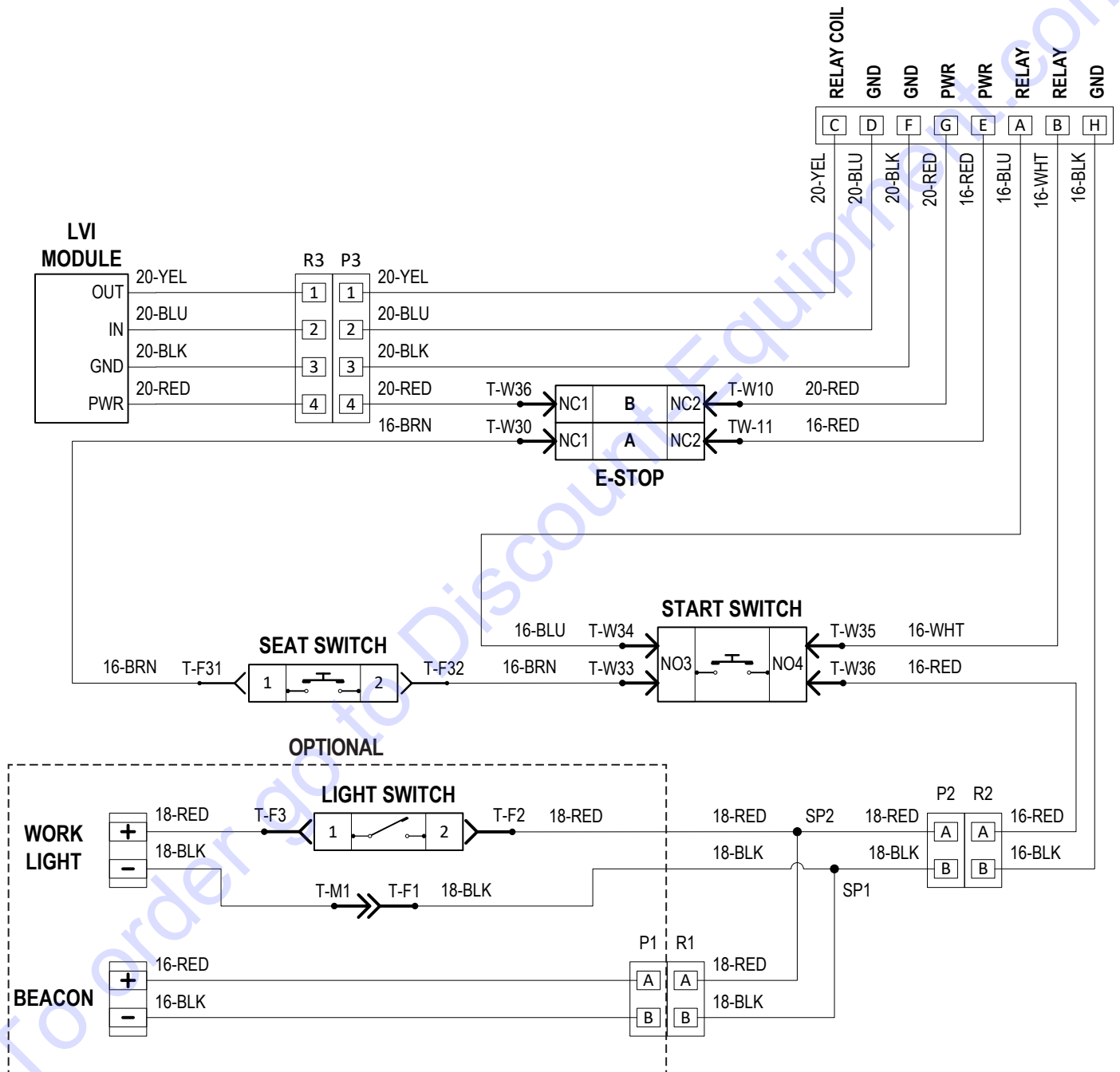

Wiring Diagrams

CHARGER WIRING DIAGRAM

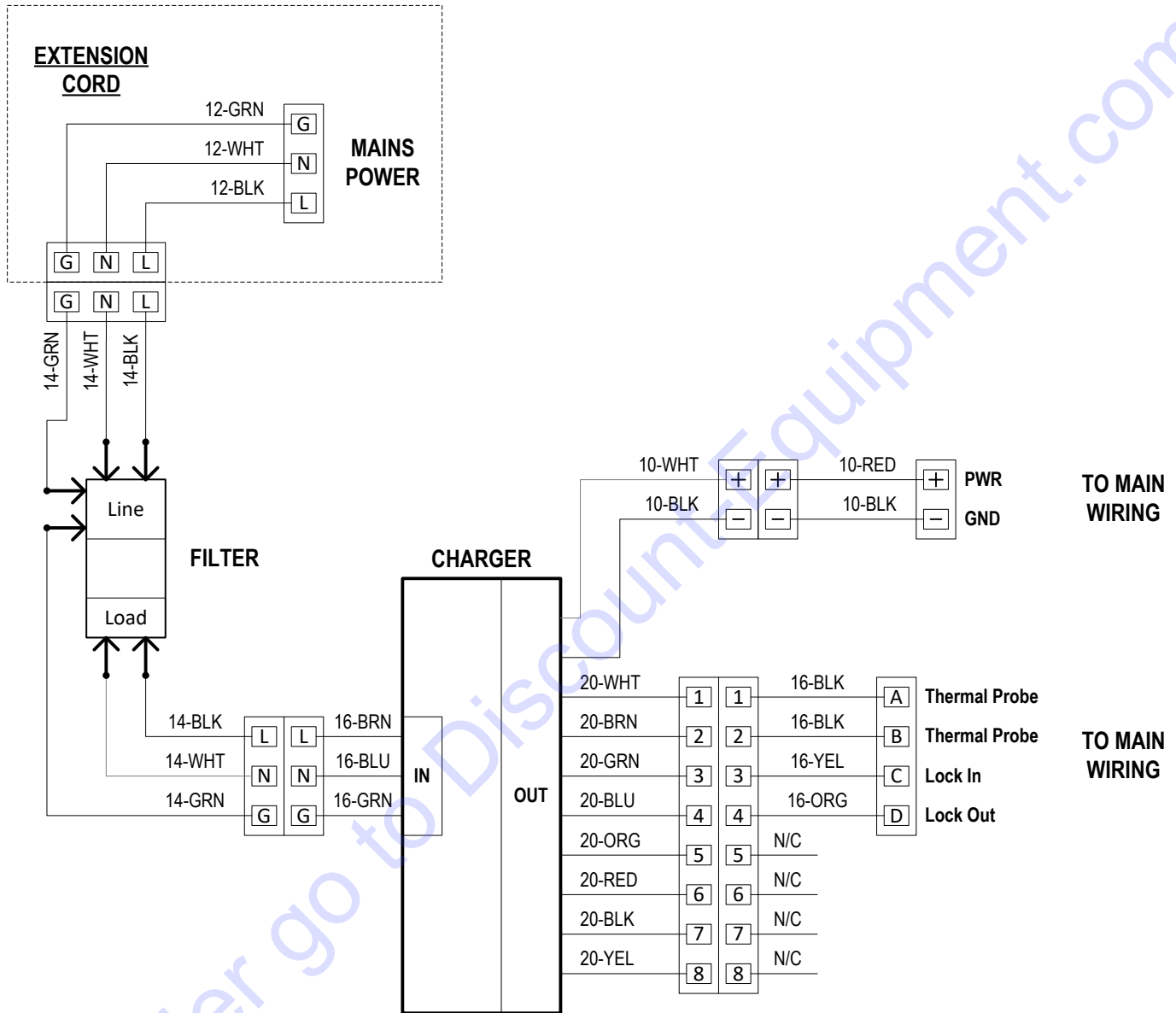

Wiring Diagrams

BATTERIES WIRING DIAGRAM

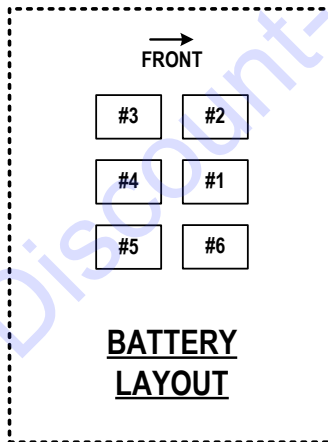
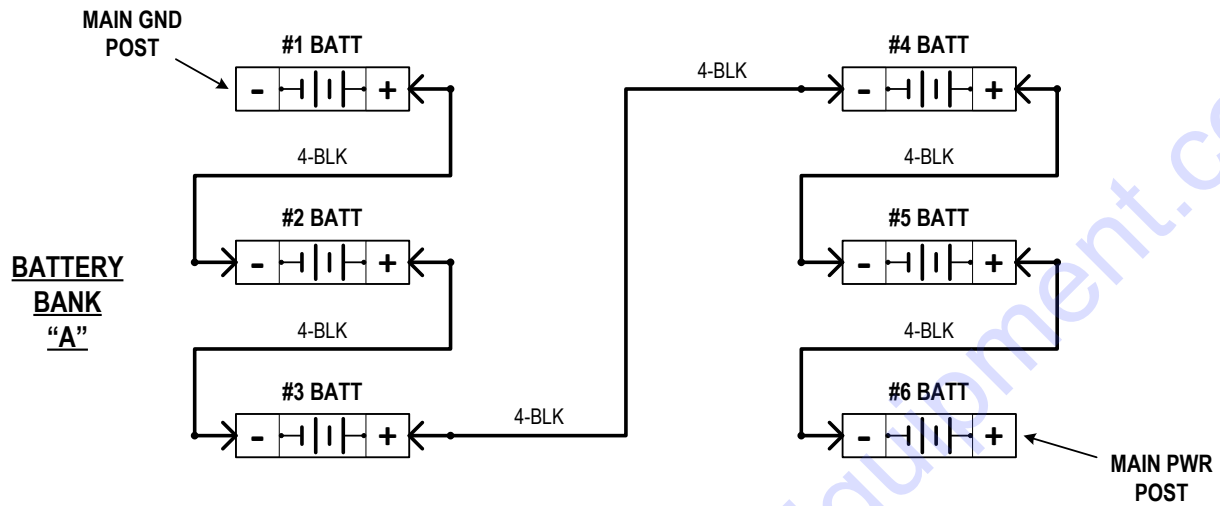

TO PURCHASE THIS PRODUCT PLEASE CONTACT US



**Equipment Financing and
Extended Warranties Available**



**Discount-Equipment.com is your online resource for
commercial and industrial quality parts and equipment sales.**

561-964-4949

visit us on line @ www.discount-equipment.com

Select an option below to find your Equipment

Search by Manufacturer

Search by Product Type

Request a Quote

We sell worldwide for the brands: Genie, Terex, JLG, MultiQuip, Mikasa, Essick, Whiteman, Mayco, Toro Stone, Diamond Products, Generac Magnum, Airman, Haulotte, Barreto, Power Blanket, Nifty Lift, Atlas Copco, Chicago Pneumatic, Allmand, Miller Curber, Skyjack, Lull, Skytrak, Tsurumi, Husquvarna Target, Stow, Wacker, Sakai, Mi-T-M, Sullair, Basic, Dynapac, MBW, Weber, Bartell, Bennar Newman, Haulotte, Ditch Runner, Menegotti, Morrison, Contec, Buddy, Crown, Edco, Wyco, Bomag, Laymor, EZ Trench, Bil-Jax, F.S. Curtis, Gehl Pavers, Heli, Honda, ICS/PowerGrit, IHI, Partner, Imer, Clipper, MMD, Koshin, Rice, CH&E, General Equipment, Amida, Coleman, NAC, Gradall, Square Shooter, Kent, Stanley, Tamco, Toku, Hatz, Kohler, Robin, Wisconsin, Northrock, Oztec, Toker TK, Rol-Air, APT, Wylie, Ingersoll Rand / Doosan, Innovatech, Con X, Ammann, Mecalac, Makinex, Smith Surface Prep, Small Line, Wanco, Yanmar