

A95

APEX® SHOT BLASTER

OPERATING & SERVICE MANUAL



Read Manual Before Operating or
Servicing Machine

402306 Rev H



TO PURCHASE THIS PRODUCT PLEASE CONTACT US



**Equipment Financing and
Extended Warranties Available**



**Discount-Equipment.com is your online resource for
commercial and industrial quality parts and equipment sales.**

561-964-4949

visit us on line @ www.discount-equipment.com

Select an option below to find your Equipment

Search by Manufacturer

Search by Product Type

Request a Quote

We sell worldwide for the brands: Genie, Terex, JLG, MultiQuip, Mikasa, Essick, Whiteman, Mayco, Toro Stone, Diamond Products, Generac Magnum, Airman, Haulotte, Barreto, Power Blanket, Nifty Lift, Atlas Copco, Chicago Pneumatic, Allmand, Miller Curber, Skyjack, Lull, Skytrak, Tsurumi, Husquvarna Target, Stow, Wacker, Sakai, Mi-T-M, Sullair, Basic, Dynapac, MBW, Weber, Bartell, Bennar Newman, Haulotte, Ditch Runner, Menegotti, Morrison, Contec, Buddy, Crown, Edco, Wyco, Bomag, Laymor, EZ Trench, Bil-Jax, F.S. Curtis, Gehl Pavers, Heli, Honda, ICS/PowerGrit, IHI, Partner, Imer, Clipper, MMD, Koshin, Rice, CH&E, General Equipment, Amida, Coleman, NAC, Gradall, Square Shooter, Kent, Stanley, Tamco, Toku, Hatz, Kohler, Robin, Wisconsin, Northrock, Oztec, Toker TK, Rol-Air, APT, Wylie, Ingersoll Rand / Doosan, Innovatech, Con X, Ammann, Mecalac, Makinex, Smith Surface Prep, Small Line, Wanco, Yanmar

Table of Contents

Table of Contents	3
Description	4
Specifications	5
Safety	6
Safety Warnings Used in Manual.....	6
Safety Labels Placed on Machine	6
General Rules for Safe Operation	7
Shot Blaster Safety Guidelines	8
Electrical Practices	9
Components and Assembly	11
Handle Assembly	11
Operating Controls.....	12
Separator	13
Shot Valve.....	13
Blast Wheel Drive	14
Blast Head Seals	14
Shot Selection.....	15
Airflow	15
Manually Moving the Machine	16
Operation	17
Cleaning Debris from Hopper	17
Adding Shot	17
Preparing for Operation	18
Start-Up Procedure.....	19
Adjusting the Blast Pattern	20
Working Direction	22
Travel Speed.....	22
Turning Off the Machine	23
Storage	23
Adjusting the Height of Magnets and Brushes.....	24
Troubleshooting Guide	25
General	25
Electrical	26
Maintenance Schedule	27
Maintenance and Inspection List.....	27
Maintenance Intervals.....	27
Maintenance	28
Removing the Blast Wheel	28
Installing the Blast Wheel	28
Removing the Liners.....	30
Installing the Liners.....	30
Adjusting Separator Cover.....	32
Removing the Shot Valve Control Cable	33
Installing the Shot Valve Control Cable	33
Setting the Amperage	34
Recommended Spare Parts List.....	35
Parts Lists	36
Overall	36
Shot Valve Control Cable Assembly	37
Separator	38
Blast Wheel Drive	40
Liners.....	42
Magnets and Brushes.....	43
Upper Handle.....	44
Lower Handle.....	46
Rear Wheels and Front Caster	47

Table of Contents

Labels 48

Wiring Diagrams 49

 Handle 49

 Blast Motor..... 50

To order go to Discount-Equipment.com

Description

MACHINE DESCRIPTION

The A95 shot blaster is designed to shot blast concrete surfaces and either remove material from the concrete surface or texture the concrete surface so material can adhere to the concrete—these steps can sometimes happen concurrently. Removing mastic or epoxy may plug the machine. The machine may be operated indoors or outdoors and can be operated in dusty conditions. The machine must not be operated in precipitation (rain or snow).

An appropriate dust collector must be connected to the machine in order to separate the dust from the shot.



FEATURES

1. **Shot Control Lever** - Precision heavy-duty shot flow control lever.
2. **Adjustable Handle** - Greatly reduces operator fatigue.
3. **8" Blast Pattern** - Allows a blasting capacity up to 400 ft²/hr.
4. **Air Wash System** - A superior in-line air wash separation system maximizes the separation of dust from the reclaimed shot resulting in prolonged part life.
5. **Rear-Facing Vacuum Port** - Improves airflow during operation.
6. **Front Swivel Caster** - Front swivel caster increases maneuverability and control.
7. **Dustless** - Operates virtually dust-free when connected to a dust collector.
8. **Curved Rebound Plenum** - Allows for more efficient shot flow and removal of dust and debris.

Specifications

Product Specifications						
Width	Length	Height	Weight	Working Width	Blasting Capacity	Power
12" (30.5 cm)	45" max. (114.3 cm) 37" min (94.0 cm)	41" max. (104.1 cm) 34" min. (86.4 cm)	121 lbs (54.9 kg)	8" (20.3 cm)	Up to 400 ft ² /hr	1.5 HP (1.12 kW)

Machine Variants			
Region	Serial Number	Max. Operating Amps*	Input Power**
Domestic (North America)	A95-10XXXX	17A	120V / 60 Hz
	A95-23XXXX	17A	120V / 60 Hz
International	A95-11XXXX	12A	230V / 50 Hz
	A95-20XXXX	16A	110V / 50 Hz

*Indicates the maximum amp draw under typical conditions.

**Indicates the expected source/supply connection rating.

Recommended Dust Collector: DL2000 or other with 200 CFM minimum rating

Safety

SAFETY WARNINGS USED IN MANUAL

Look for the safety hazard warning symbol.



This symbol is used to alert the operator of safety hazards. It is used along with the words DANGER, WARNING and CAUTION.



“DANGER” identifies immediate hazards which will result in serious injury or death.



“WARNING” identifies potential hazards which could result in serious injury or death.



“CAUTION” identifies hazardous situations which may result in minor injury and/or could result in damage or destruction of equipment.

SAFETY LABELS PLACED ON MACHINE



Wear Personal Protective Equipment
Read Manual

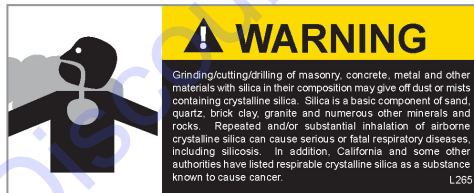

Silica Dust Warning



Electrical Hazard

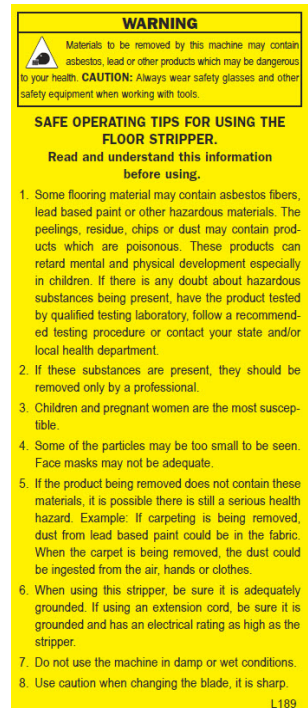

Possible Asbestos Exposure
Warning

GENERAL RULES FOR SAFE OPERATION

Before use, anyone operating or performing maintenance on this equipment must read and understand this manual, as well as any labels packaged with or attached to the machine and its components. Read the manual carefully to learn equipment applications and limitations, as well as potential hazards associated with this type of equipment. Keep manual near machine at all times. If your manual is lost or damaged, contact Discount-equipment for a replacement.

Personal

Dress properly and use safety gear.

Do not wear loose clothing; it may be caught in moving parts. Anyone in the work area must wear safety goggles or glasses and hearing protection. Wear a dust mask for dusty operations. Hard hats, face shields, safety shoes, etc. should be worn when specified or necessary.

Maintain control; stay alert.

Keep proper footing and balance, and maintain a firm grip. Observe surroundings at all times. Do not use when tired, distracted, or under the influence of drugs, alcohol, or any medication that may cause decreased control.

Keep hands away from all moving parts and tooling.

Wear gloves when changing tooling. Remove tooling when machine is not in use and/or lower cutting head to the floor.

Do not force equipment.

Equipment will perform best at the rate for which it was designed. Excessive force only causes operator fatigue, increased wear, and reduced control.

Environment

Avoid use in dangerous environments.

Do not use in rain, damp or wet locations, or in the presence of explosive atmospheres (gaseous fumes, dust, or flammable materials). Remove materials or debris that may be ignited by sparks. Keep work area tidy and well-lit - a cluttered or dark work area may lead to accidents.

Protect others in the work area and be aware of surroundings.

Provide barriers or shields as needed to protect others from debris and machine operation. Children and other bystanders should be kept at a safe distance from the work area to avoid distracting the operator and/or coming into contact with the machine. Operator should be aware of who is around them and their proximity. Support personnel should never stand next to, in front of, or behind the machine while the machine is running. Operator should look behind them before backing up.

Guard against electric shock.

Ensure that machine is connected to a properly grounded outlet. Prevent bodily contact with grounded surfaces, e.g. pipes, radiators, ranges, and refrigerators. When scoring or making cuts, always check the work area for hidden wires or pipes.

Maintenance & Repairs

Begin maintenance work only when the machine is shut down, unplugged, and cooled down.

Use proper cleaning agents.

Ensure that all cleaning rags are fiber-free; do not use any aggressive cleaning products.

Schedule regular maintenance check-ups.

Ensure machine is properly cleaned and serviced. Remove all traces of oil, combustible fuel, or cleaning fluids from the machine and its connections and fittings. Retighten all loose fittings found during maintenance and repair work. Loose or damaged parts should be replaced immediately; use only NFE parts.

Do not weld or flame-cut on the machine during repairs, or make changes to machine without authorization from NFE.

Equipment

Use proper parts and accessories.

Only use NFE-approved or recommended parts and accessories. Using any that are not recommended may be hazardous.

Ensure accessories are properly installed and maintained.

Do not permanently remove a guard or other safety device when installing an accessory or attachment.

Inspect for damaged parts.

Check for misalignment, binding of moving parts, loose fasteners, improper mounting, broken parts, and any other conditions that may affect operation. If abnormal noise or vibration occurs, turn the machine off immediately. Do not use damaged equipment until repaired. Do not use if power switch does not turn machine on and off. For all repairs, insist on only identical NFE replacement parts.

Maintain equipment and labels.

Keep handles dry, clean, and free from oil and grease. Keep cutting edges sharp and clean. Follow instructions for lubricating and changing accessories. Motor and switches should be completely enclosed at all times with no exposed wiring. Inspect cord regularly. Labels carry important information; if unreadable or missing, contact Discount-equipment for a free replacement.

Avoid accidental starting; store idle equipment.

When not in use, ensure that the machine is unplugged; do not turn on before plugging in. Store in a dry, secured place. Remove tooling when storing, and keep away from children.

Safety

SHOT BLASTER SAFETY GUIDELINES

Before use, anyone operating this equipment must read and understand these safety instructions.

Shot Blasting

Beware of hidden obtrusions.

Watch out for hidden dangers and protrusions in flooring. Do not use on largely uneven surfaces.

Avoid contact with hot shroud.

Do not touch the shroud without proper hand protection. Both become hot during operation and remain hot after stopping the machine.

Provide barriers, shields, or safety glasses as needed to protect others from debris.

Use for correct applications.

Do not force equipment to do heavier duty work than it was made for.

Use a magnetic sweep immediately after blasting.

Steel shot that is left on the walking surfaces creates a slipping hazard which could cause unexpected falls.

Dust Collection

Turn off machine before working with dust collector.

Do not switch off or remove the dust collector while the machine is running.

Use with appropriate dust collecting system.

Do not operate machine designed for use with a dust collector without the dust collector. Ensure dust collector is on and operating properly while grinding.

Dispose of collected waste.

Do not leave the dust collector bag full of waste. Handle and dispose of bag and waste in accordance with all applicable local, state, and federal regulations. The dust bin of a connected dust collector must be emptied before transportation.



WARNING: GRINDING/CUTTING/DRILLING OF MASONRY, CONCRETE, METAL AND OTHER MATERIALS CAN GENERATE DUST, MISTS AND FUMES CONTAINING CHEMICALS KNOWN TO CAUSE SERIOUS FATAL INJURY OR ILLNESS, SUCH AS RESPIRATORY DISEASE, CANCER, BIRTH DEFECTS OR OTHER REPRODUCTIVE HARM. IF YOU ARE UNFAMILIAR WITH THE RISKS ASSOCIATED WITH THE PARTICULAR MATERIAL BEING CUT, REVIEW THE MATERIAL SAFETY DATA SHEET AND/OR CONSULT YOU EMPLOYER, THE MATERIAL MANUFACTURER/SUPPLIER, GOVERNMENTAL AGENCIES SUCH AS OSHA AND NIOSH AND OTHER AUTHORITIES ON HAZARDOUS MATERIALS. CALIFORNIA AND SOME OTHER AUTHORITIES, FOR INSTANCE, HAVE PUBLISHED LISTS OF SUBSTANCES KNOWN TO CAUSE CANCER, REPRODUCTIVE TOXICITY, OR OTHER HARMFUL EFFECTS. CONTROL DUST, MIST AND FUMES AT THE SOURCE WHERE POSSIBLE. IN THIS REGARD USE GOOD WORK PRACTICES AND FOLLOW THE RECOMMENDATIONS OF THE MANUFACTURER/SUPPLIER, OSHA/NIOSH, AND OCCUPATIONAL AND TRADE ASSOCIATIONS. WHEN THE HAZARDS FROM INHALATION OF DUST, MISTS AND FUMES CANNOT BE ELIMINATED, THE OPERATOR AND ANY BYSTANDERS SHOULD ALWAYS WEAR A RESPIRATOR APPROVED BY OSHA/MSHA FOR THE MATERIAL BEING CUT.

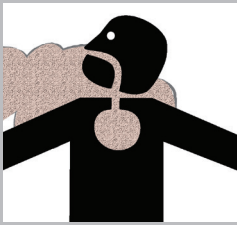

ELECTRICAL PRACTICES



WARNING: ELECTRICAL CORDS CAN BE HAZARDOUS. MISUSE CAN RESULT IN FIRE OR DEATH BY ELECTRICAL SHOCK. READ CAREFULLY AND FOLLOW ALL DIRECTIONS.



CAUTION: ALWAYS FOLLOW APPLICABLE ELECTRICAL CODES, STANDARDS AND/OR REGULATIONS. CONSULT YOUR LOCAL ELECTRICAL AUTHORITY OR A LICENSED ELECTRICIAN BEFORE ATTEMPTING TO MODIFY AN ELECTRICAL INSTALLATION. ENSURE THAT CIRCUIT AND GROUND FAULT PROTECTION DEVICES AND ALL OTHER ELECTRICAL SAFETY EQUIPMENT ARE FUNCTIONING PROPERLY.

Extension Cord Requirements

- Ensure the cord type is suitable for the application and location. If you are unsure about your cord type, consult a qualified electrical professional or electrician.
- Ground your equipment. The equipment must be plugged into an appropriate outlet, one which is properly installed and grounded in accordance with all codes and ordinances. Do NOT modify the plug provided with the equipment. Never remove the grounding prong from the plug.
- Do not remove, bend or modify any metal prongs or pins of the plug. Modifications to power cords and/or plugs may result injury and/or equipment damage.
- FULLY INSERT plug into outlet.
- Do not use excessive force to make connections.
- Never unplug by pulling the cord from the outlet. Pull plug rather than cord to reduce the risk of damage.
- Regularly examine your extension cord and ensure it is in good electrical condition. Never use a damaged cord—either replace it or have it repaired by a qualified person.
- Protect your extension cords from sharp objects, excessive heat and damp or wet areas. Keep the cord away from oil, cutting edges and moving parts.
- Do not drive, drag or place objects over cord.
- Avoid overheating. Uncoil cord and do not cover it with any material.
- Avoid accidental starting. Be sure equipment is turned off before plugging in. Do not use equipment if the power switch does not turn the equipment on and off.
- Make sure equipment is not running before disconnecting cord.
- Unplug equipment. When not in use and before changing accessories or performing maintenance, unplug the machine.

Extension Cord Selection

All cords should be sized appropriately to reduce the risk of damage, fire or reduced performance. Reference the table in this section for cord sizes.

Safety

ELECTRICAL PRACTICES (CONT'D)

How to Use This Table

1. Determine your supply voltage.
2. Determine the total length of your cord including all extension cords.
3. Determine the maximum amp draw for your machine.
4. Trace your voltage across the top of the table to the first length that is greater than or equal to your cord length.
5. Follow the column down to the first row that contains a maximum amp draw greater than or equal to yours.
6. This cell contains the minimum wire size for your application.

Example

Application: Max Amps = 11A, Length = 40ft, Voltage = 120V

Solution: 40ft is between the 25ft and 50ft columns, so the larger of the two columns is chosen. Likewise, 11A is between the 10A and 12A rows, so the larger of the two rows is chosen. 14 AWG (2.5mm²) is the minimum recommended wire size for this example.

		Single Phase Equipment			
Max Length	120V Supply	25ft (7.5m)	50ft (15m)	75ft (22.5m)	100ft (30m)
	230V Supply	50ft (15m)	100ft (30m)	150ft (45m)	200ft (60m)
Max Amps		Minimum Wire Size			
8		16 AWG (1.5mm ²)	16 AWG (1.5mm ²)	16 AWG (1.5mm ²)	16 AWG (1.5mm ²)
10		16 AWG (1.5mm ²)	16 AWG (1.5mm ²)	16 AWG (1.5mm ²)	16 AWG (1.5mm ²)
12		14 AWG (2.5mm ²)	14 AWG (2.5mm ²)	14 AWG (2.5mm ²)	14 AWG (2.5mm ²)
14		14 AWG (2.5mm ²)	14 AWG (2.5mm ²)	14 AWG (2.5mm ²)	14 AWG (2.5mm ²)

Extension Cord Sizes

Single Phase Equipment							
Max Length	120V Supply	25ft (7.5m)	50ft (15m)	75ft (25m)	100ft (30m)	150ft (45m)	200ft (60m)
	230V Supply	50ft (15m)	100ft (30m)	150ft (45m)	200ft (60m)	300ft (90m)	400ft (120m)
Max Amps		Minimum Wire Size					
8		16 AWG (1.5mm ²)	16 AWG (1.5mm ²)	16 AWG (1.5mm ²)	16 AWG (1.5mm ²)	14 AWG (2.5mm ²)	14 AWG (2.5mm ²)
10		16 AWG (1.5mm ²)	16 AWG (1.5mm ²)	16 AWG (1.5mm ²)	16 AWG (1.5mm ²)	14 AWG (2.5mm ²)	12 AWG (4mm ²)
12		14 AWG (2.5mm ²)	14 AWG (2.5mm ²)	14 AWG (2.5mm ²)	14 AWG (2.5mm ²)	12 AWG (4mm ²)	12 AWG (4mm ²)
14		14 AWG (2.5mm ²)	14 AWG (2.5mm ²)	14 AWG (2.5mm ²)	14 AWG (2.5mm ²)	12 AWG (4mm ²)	10 AWG (6mm ²)
16		14 AWG (2.5mm ²)	14 AWG (2.5mm ²)	14 AWG (2.5mm ²)	14 AWG (2.5mm ²)	12 AWG (4mm ²)	10 AWG (6mm ²)
18		14 AWG (2.5mm ²)	14 AWG (2.5mm ²)	14 AWG (2.5mm ²)	12 AWG (4mm ²)	12 AWG (4mm ²)	10 AWG (6mm ²)
20		12 AWG (4mm ²)	12 AWG (4mm ²)	12 AWG (4mm ²)	12 AWG (4mm ²)	10 AWG (6mm ²)	10 AWG (6mm ²)
25		12 AWG (4mm ²)	12 AWG (4mm ²)	12 AWG (4mm ²)	12 AWG (4mm ²)	10 AWG (6mm ²)	8 AWG (10mm ²)
30		10 AWG (6mm ²)	10 AWG (6mm ²)	10 AWG (6mm ²)	10 AWG (6mm ²)	8 AWG (10mm ²)	8 AWG (10mm ²)

Note: The table is based on a <10% voltage loss, data from the U.S. National Electrical Code Tables 400.5(A) & 400.5(B) and typical resistances for copper wire.

Components and Assembly

HANDLE ASSEMBLY (FIGURES 1-2)



CAUTION: THE HANDLE IS ONLY FIXED WITH TWO PULL-OUT PINS AND CANNOT BE USED AS A LIFTING POINT FOR HOISTING.

The machine comes with the handle disassembled. To assemble the handle:

1. Insert handle into handle frame and align holes to the desired position keeping the motor cable behind the handle.
2. Insert the two pull-out pins.
3. Attach shot control lever using the screws provided.



FIG. 1

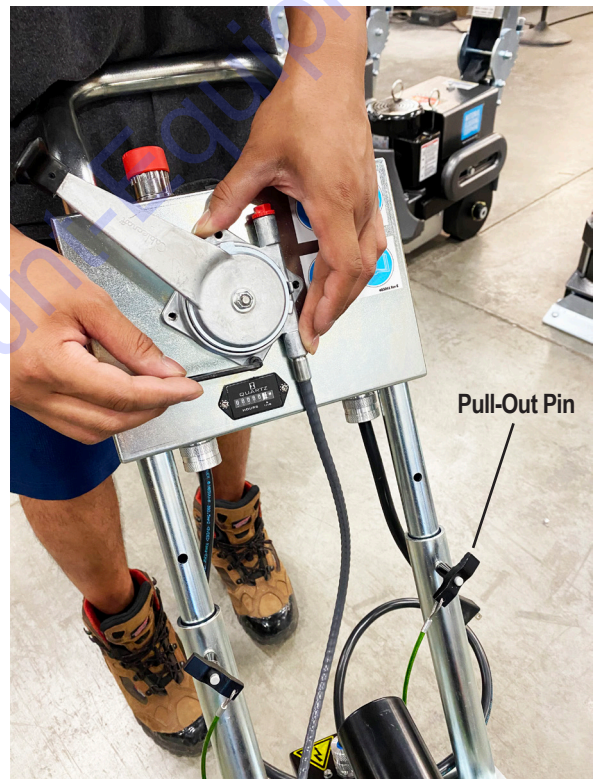

FIG. 2

Components and Assembly

OPERATING CONTROLS (FIGURE 3)

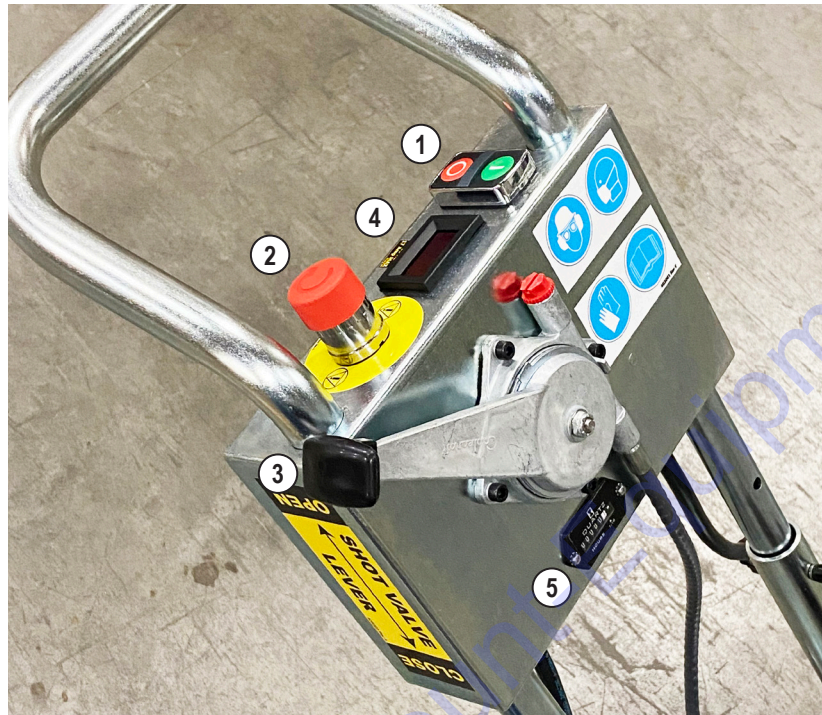

FIG. 3

[1] Blast Wheel Start/Stop Buttons

Pushing the START button starts the blast wheel motor, pushing the STOP button stops the motor.

[2] Emergency Stop Switch

In case of an emergency push the emergency stop switch to immediately stop the blast wheel motor. To release the emergency stop switch, twist the red button and pull it upwards. The emergency stop switch must be released before the blast wheel motor can be started.

[3] Shot Control Lever

Controls the shot valve which regulates the flow of shot to the blast wheel. The shot throughput is set by changing the lever position.

[4] Ammeter

Indicates the total amp draw of the machine. The ammeter illuminates when the blast wheel START button is pushed. The reading increases as the shot valve is opened. See label located near ammeter for the maximum operating amps rating.

[5] Hour Meter

Displays the actual working hours performed by the blast wheel.

[6] Shot Valve Stop (Not Shown)

Limits the maximum opening of the shot valve.

Components and Assembly

SEPARATOR (FIGURE 4)

The separator (1) is mounted inside the cover (2). The dust collector is connected to the hose connector (3) and generates the appropriate airflow within the separator to separate the dust from the shot. The dust flows to the dust collector, while the shot passes through the removable mesh tray (4) and drops back into the hopper (5). The mesh tray prevents coarse contaminants from getting to the blast wheel.

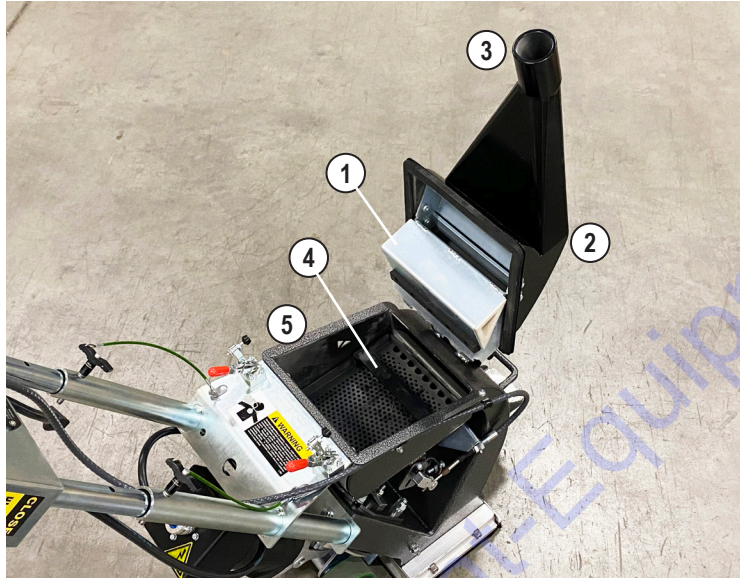

FIG. 4

SHOT VALVE (FIGURES 5-6)

The shot valve (1) regulates the flow of shot to the blast wheel and is located between the hopper (2) and the feed spout (3). The valve is controlled by the shot control lever (4) via the control cable (5). Maximum feed occurs with the lever completely open. The shop valve stop (6) sets the maximum opening of the shot valve.

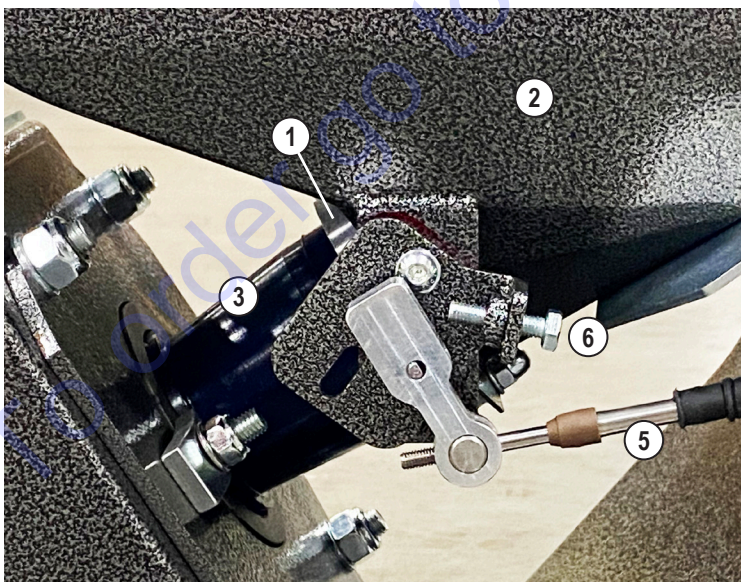

FIG. 5

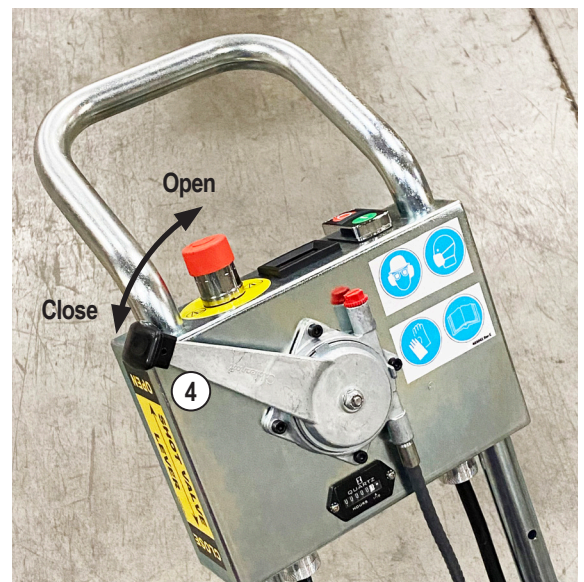

FIG. 6

Components and Assembly

BLAST WHEEL DRIVE (FIGURE 7)

The blast wheel (1) throws shot at the surface to be treated. It is surrounded by replaceable liners (2) and is driven by an electric motor (3) via the wheel hub (4). Shot is fed to the blast wheel through the feed spout. The position of the control cage (5) determines the direction shot is thrown to the surface and the evenness of the blast pattern.

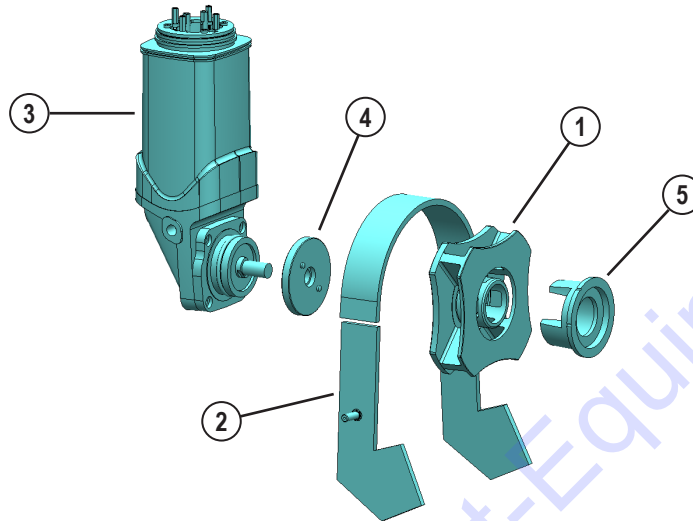

FIG. 7

BLAST HEAD SEALS (FIGURE 8)

The blast head opening has magnets (1) on the front and sides with brushes (2) on the outside. The rear has a brush only (3). Together the magnets and brushes regulate the airflow inside the machine and seal against shot spraying out from the blast head. Airflow enters the machine through the rear brush and travels through the plenum transporting shot and dust upwards to the separator.

The correct height adjustment is .25-.32" (6-8 mm) from the bottom of the magnets to the surface and is important for optimum machine performance. In general, the magnets should be set at the maximum height of .32" (8 mm) for very rough surfaces and set at the minimum height of .25" (6 mm) for very smooth surfaces. See *Adjusting the Height of Magnets and Brushes* for the adjustment procedure.

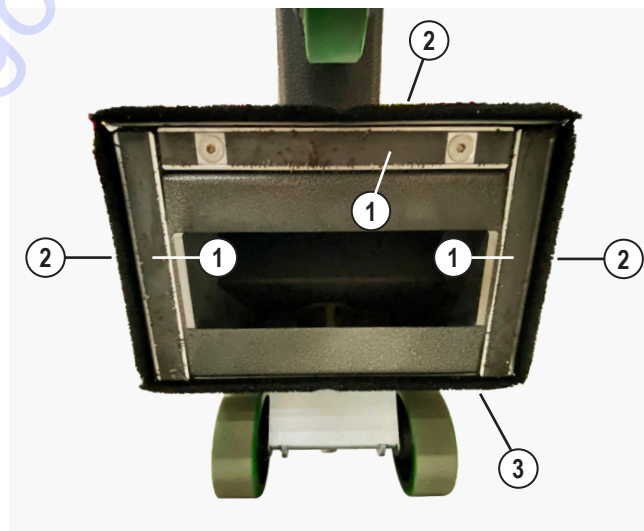

FIG. 8

Components and Assembly

SHOT SELECTION

Selection of shot is important, as this is the material that profiles the surface. The use of incorrect shot increases wear on the machine. Contact Discount-equipment regarding the best shot to use for your application.

S280 Shot (Approx. Size: .028")

Often used when the surface is to be sealed afterwards.

Applications:

- Creating fine profiles on surfaces such as vacuum concrete and non-glazed tiles
- Removing thin layers of paint

S330 Shot (Approx. Size: .033")

Applications:

- Creating a fine to medium texture on concrete
- Removing glazing from tiles prior to sealing with anti-skid coating
- Removing old impregnations and coatings about .04" (1 mm) thick

AIRFLOW (FIGURE 9)

The following illustration shows the airflow through the machine.

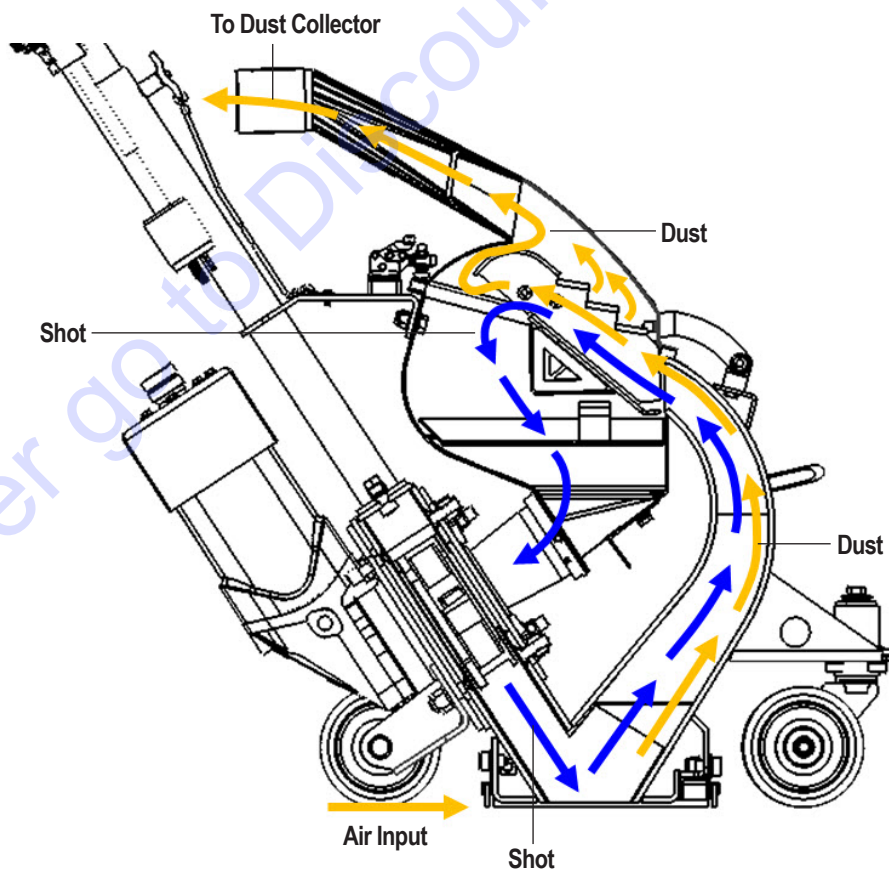

FIG. 9

Components and Assembly

MANUALLY MOVING THE MACHINE (FIGURE 10)



CAUTION: WHEN MOVING MACHINE, DO NOT DROP ON REAR WHEELS AS THIS COULD CAUSE THEM TO GO OUT OF ADJUSTMENT.

When manually moving the machine around the jobsite, keep the machine tilted back so the front caster is about 4-8" (10-20 mm) off the floor. Moving the machine using the rear wheels helps to keep the magnets from picking up debris.

Note: Keep the shot valve closed while moving the machine otherwise shot will drop onto the floor.



FIG. 10



WARNING: BEFORE PERFORMING MAINTENANCE, ALWAYS DISCONNECT THE MACHINE FROM POWER TO PREVENT ACCIDENTAL START-UP.

CLEANING DEBRIS FROM HOPPER (FIGURE 11)



WARNING: USE GLOVES WHEN REMOVING DEBRIS FROM HOPPER. STAPLES, NAILS OR OTHER SHARP OBJECTS THAT MAY HAVE BEEN PICKED UP DURING USE COULD CAUSE INJURY TO BARE HANDS.

1. Release the clamps (1), then open the cover (2).
2. Remove the mesh tray (3) from the hopper and empty the debris.
3. Replace the tray.
4. Close the cover and secure the clamps.

ADDING SHOT (FIGURE 11)

1. Make sure the shot valve is closed.
2. Release the clamps (1), then open the cover (2).
3. Ensure the mesh tray (3) is in place.
4. Fill the hopper (4) with shot to a level just below the mesh tray (3).
5. Close the cover and secure the clamps.

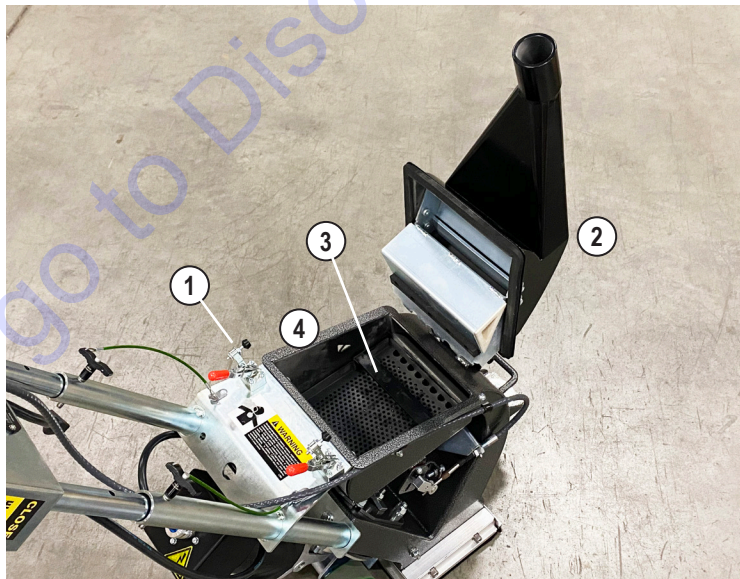

FIG. 11

Operation

PREPARING FOR OPERATION

Complete the following before start-up:

- Ensure all protective covers are attached correctly.
- Check that all parts are assembled correctly.
- Check that all fasteners are tight.
- Check parts for damage and wear; replace if necessary.
- Make sure the hopper is free of debris and that the shot valve functions properly.
- Check the level of shot in the hopper; fill if necessary.
- It is important to operate the dust collector on a separate circuit from the shot blaster. The shot blaster needs the full amp draw to operate effectively.
- Check that the dust collector is connected correctly and all hose connections are tight.
- Empty dust collector container.
- Check that the magnet height is approximately .25-.32" (6-8 mm) from surface. See *Adjusting the Height of Magnets and Brushes* for the adjustment procedure.
- Sweep surface for loose parts prior to operation. Ensure that machine can travel over all inequalities on the surface; small inequalities like weld seams or floor joints are not an issue.
- Run magnetic sweep over surface to remove any metallic debris.
- Preload the magnets—Place a small amount of shot on the floor in front of the machine and push the machine back and forth over the shot until gone to create a seal.

Note: Whenever the machine is not used for blasting, the shot valve must be closed.

START-UP PROCEDURE (FIGURE 12-13)



WARNING: DO NOT TILT BACK THE MACHINE WHILE BLASTING. TILTING MACHINE WILL CAUSE SHOT TO SPRAY OUT AND COULD CAUSE INJURY.



CAUTION: WHEN BLASTING CONCRETE OR ASPHALT, ONLY OPEN THE SHOT VALVE WHEN THE MACHINE IS MOVING. IF THE MACHINE IS NOT MOVING AND THE VALVE IS OPENED, DEEP HOLES WILL BE BLASTED INTO THE SURFACE WITHIN SECONDS.



CAUTION: EMPTY THE DUST COLLECTOR REGULARLY.

1. Turn on the dust collector.
2. Plug machine into the power source.
3. Check that the shot valve is closed. The shot control lever (1) should be in the closed position.
4. Release the emergency stop switch (2) by twisting the red button and pulling it upwards.
5. Push the blast wheel START button (3) to start the blast wheel motor and allow the motor to reach a steady state.
Note: The ammeter (4) illuminates when the blast wheel START button is pushed.
6. Start pushing the machine forward slowly.
7. With the machine moving forward, gradually open the shot valve allowing shot to flow to the blast wheel.
Note: The ammeter reading will increase as the shot valve opens. See label located near ammeter for the maximum operating amps rating.
8. Continue to slowly push the machine forward and watch the blasted area carefully. If necessary, readjust the blast pattern, use the shot valve stop to adjust the maximum opening of the shot valve, or change the travel speed to achieve the desired profile.



FIG. 12

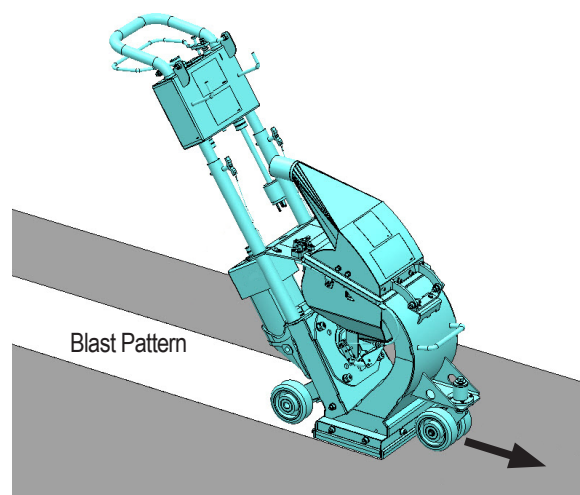

FIG. 13

Operation

ADJUSTING THE BLAST PATTERN



WARNING: BEFORE ADJUSTING THE MACHINE, ALWAYS DISCONNECT THE MACHINE FROM POWER TO PREVENT ACCIDENTAL STARTUP.

Factors That Affect the Blast Pattern

- **Position of the control cage:** The correct adjustment of the control cage is the most important factor in achieving an even blast pattern and optimum machine performance. The position of the control cage determines the direction shot is thrown to the surface and the evenness of the blast pattern. Incorrect adjustment of the control cage results in premature wear and reduced blasting performance.
- **Changing blast wheel and control cage:** After changing the blast wheel and control cage, the blast pattern must be checked and readjusted.
- **Worn blast wheel and control cage:** The blast pattern changes with increased wear of the blast wheel and control cage.
- **Shot size:** The size of shot affects the blast pattern. Check the blast pattern whenever the shot is changed and readjust if needed.

Adjusting the Control Cage (Figures 14-17)

When blasting the surface, material should be removed within the whole width of the blast opening and the blast pattern should be even. Evenness of the blast pattern is determined by the position of the control cage. The control cage grooves indicate the position of the opening through which the shot is fed onto the blast wheel. As a starting point, the control cage grooves should be aligned as shown. If the machine produces a one-sided, uneven blast pattern, adjust the control cage as follows:

1. Loosen the cage clamps (1). Remove the feed spout (2) for easier adjustment of the control cage.
2. Observe the evenness of the blast pattern to determine the direction of adjustment. View from the front of machine. Make adjustments in fine increments.
 - If the blast pattern is too heavy to the left, adjust control cage (3) counterclockwise to achieve an even pattern.
 - If the blast pattern is too heavy to the right, adjust control cage (3) clockwise to achieve an even pattern.
3. Tighten the cage clamps. Create a blast pattern to check the adjustment.
4. If blast pattern is even, proceed with blasting. If blast pattern is still uneven, repeat the process.

Note: The control cage must be centered with the blast wheel to reduce wear and avoid grinding shot. If a grinding noise can be heard after the control cage has been adjusted, it must be centered: loosen the cage clamps; move the control cage within the opening to understand the play in the system; center the control cage; tighten the cage clamps; start the machine. Repeat process until the grinding noise can no longer be heard—this may take several attempts. (If the grinding noise is still present, remove the control cage and inspect for wear marks to help determine the adjustment direction.)

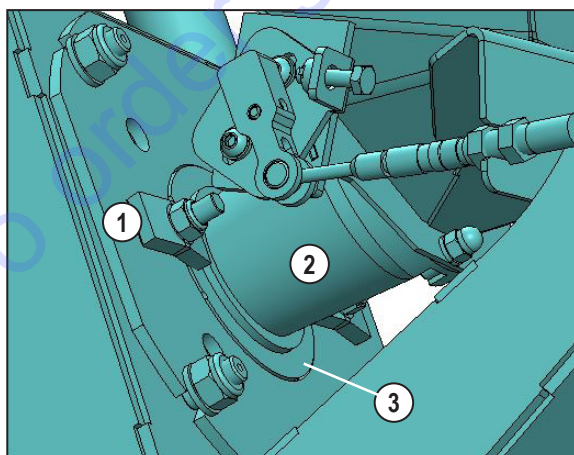

FIG. 14

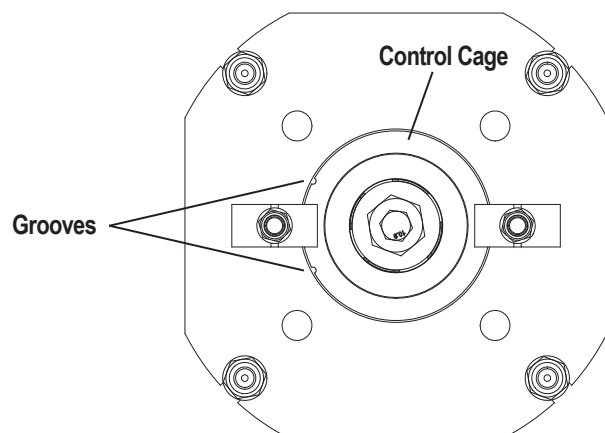

FIG. 15

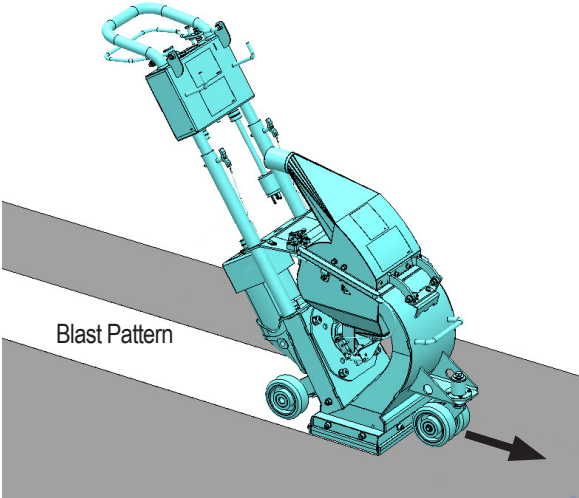

FIG. 16



DIRECTION OF TRAVEL



DIRECTION OF TRAVEL



DIRECTION OF TRAVEL

FIG. 17

Operation

WORKING DIRECTION (FIGURE 18)



CAUTION: TAKE CARE NOT TO TRIP OVER THE POWER CORD AND DUST HOSE.



CAUTION: CLOSE THE SHOT VALVE BEFORE TURNING THE MACHINE AROUND TO MAINTAIN AN EVEN BLAST PATTERN AND AVOID DAMAGING THE FLOOR.

1. Carry out blasting in parallel back-and-forth tracks working away from the dust collector. Make sure the power cord and dust hose do not become twisted. Keep an eye on the maximum cord and hose lengths and reposition if needed.
2. When the end of a track is reached, close the shot valve while keeping the blast motor running. Turn the machine around by swinging the front end in a loop going forward.

Note: When turning the machine around, do NOT back up. Rather, swing the front end in a loop going forward to prevent losing the bottom shot seal and causing the front caster to swivel backwards.

3. Align the machine for the next track, reopen the shot valve and proceed to blast the new track with minimal overlapping.
4. Repeat this process to complete the surface, moving away from the dust collector to the unblasted surface. When finished, move the dust collector to the completed surface and blast the area where the dust collector was located.

Note: If a fine blasting result is required, it is necessary to blast in the same direction.

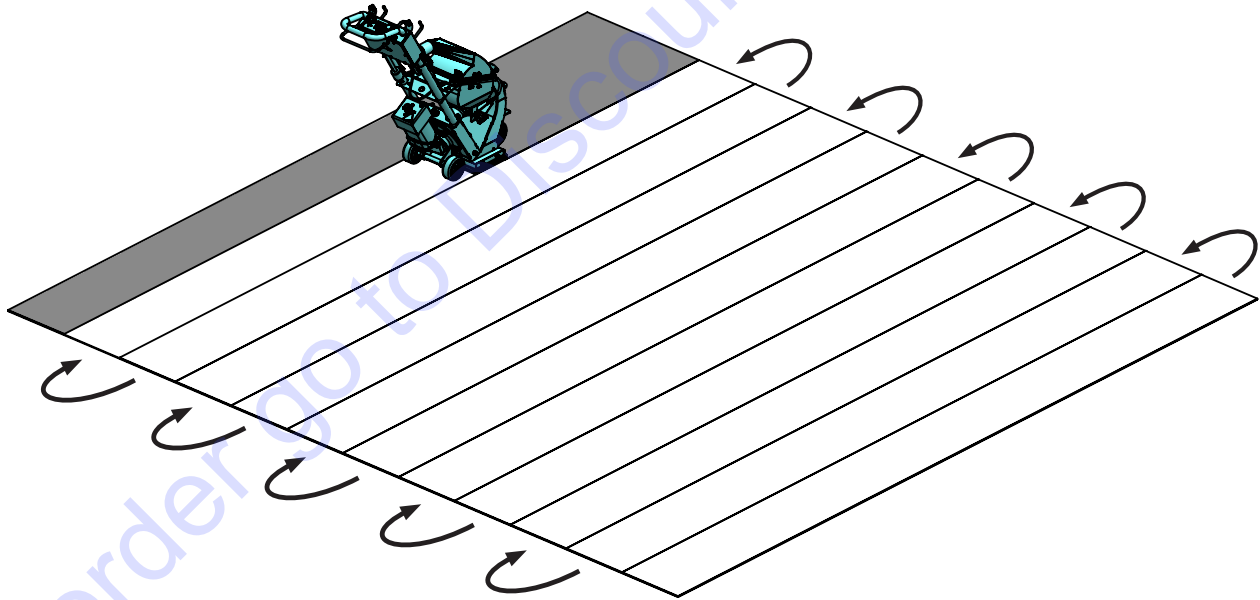

FIG. 18

TRAVEL SPEED

Selecting the right travel speed is important for achieving a good blasting result and depends on the type of surface material and desired profiling. Determine the right travel speed by observing the blasted surface and varying the travel speed during operation.

- Slight profiling on concrete requires a higher travel speed than coarse profiling.
- Blasting on steel requires a very low travel speed of the machine.

TURNING OFF THE MACHINE (FIGURE 19)



WARNING: USE A MAGNETIC SWEEP IMMEDIATELY AFTER BLASTING. STEEL SHOT THAT IS LEFT ON THE WALKING SURFACES CREATES A SLIPPING HAZARD WHICH COULD CAUSE UNEXPECTED FALLS.

1. Close the shot valve by moving the shot control lever (1) to the closed position.
2. Continue pushing the machine forward until the shot valve is closed to prevent holes from being blasted into the floor.
3. Push the blast wheel STOP button (2) to stop the blast wheel motor.
4. Push down the emergency stop switch (3) to avoid starting the machine unexpectedly.
5. Unplug the machine from the power source.
6. Turn off dust collector.

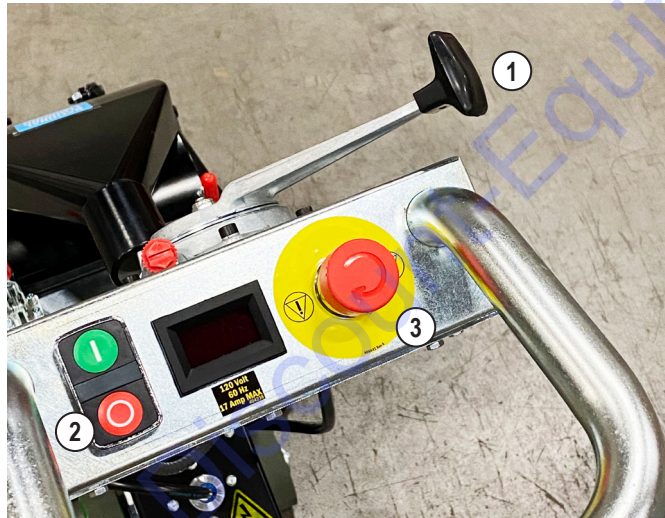

FIG. 19

STORAGE



WARNING: DO NOT USE YOUR BARE HANDS TO REMOVE SHOT FROM MAGNETS. STAPLES, NAILS OR OTHER SHARP OBJECTS THAT MAY HAVE BEEN PICKED UP DURING USE COULD CAUSE INJURY.

Before storing the machine for a long period, complete the following:

1. Remove all shot from the machine. It is effective to use the dust collector hose to vacuum out the hopper.
2. Scrape shot from the magnets using a putty knife or similar tool.
3. Clean the machine.
4. Store the machine in a dry area.
5. Cover the machine.

Operation

ADJUSTING THE HEIGHT OF MAGNETS AND BRUSHES (FIGURE 20)



WARNING: BEFORE ADJUSTING THE MACHINE, ALWAYS DISCONNECT THE MACHINE FROM POWER TO PREVENT ACCIDENTAL STARTUP.



WARNING: DO NOT USE YOUR BARE HANDS TO REMOVE SHOT FROM MAGNETS. STAPLES, NAILS OR OTHER SHARP OBJECTS THAT MAY HAVE BEEN PICKED UP DURING USE COULD CAUSE INJURY.

The correct height adjustment of the magnets is .25-.32" (6-8 mm) and is important for regulating airflow through the machine and creating a good seal. The magnets should be set at the maximum height of .32" (8 mm) for very rough surfaces. For very smooth surfaces the magnets should be set at the minimum height of .25" (6 mm).

1. Remove the front and side brushes from the machine.
2. Tip the machine up and scrape the shot from the magnets using a putty knife or similar tool.
3. Adjust the rear wheel bracket so the bottom of the magnets are .25-.32" (6-8 mm) above the floor.
4. Adjust the washer stack height of the front caster so the bottom of the magnets are .25-.32" (6-8 mm) above the floor.
5. Replace the front and side brushes flush with the floor.
6. Rear brush height should be 0-.125" (0-3 mm) from the floor.

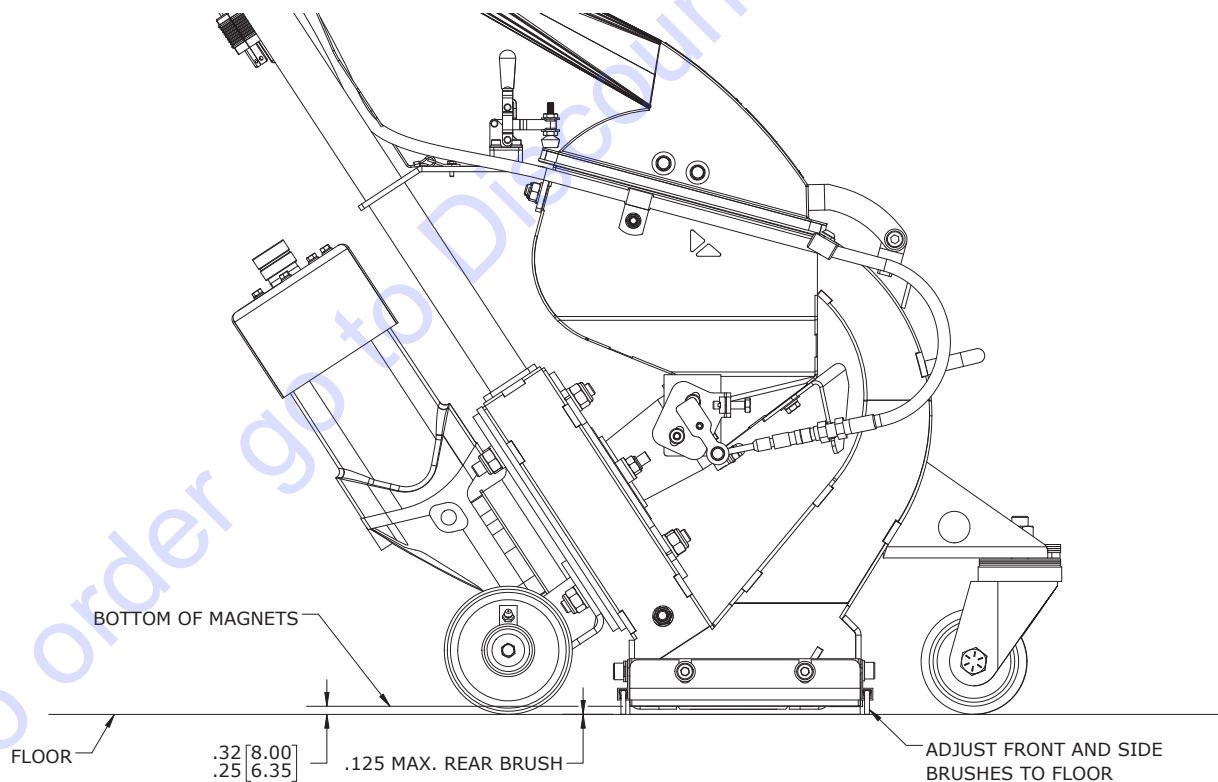

FIG. 20

Troubleshooting Guide



WARNING: BEFORE PERFORMING MAINTENANCE, ALWAYS DISCONNECT THE MACHINE FROM POWER TO PREVENT ACCIDENTAL STARTUP.

GENERAL

Problem	Cause	Solution
Unusual vibrations or noise	Control cage not centered.	Center control cage.
	Blast wheel installed incorrectly.	Check pin on wheel hub.
	Loose blast wheel nut.	Replace and/or tighten nut.
	Wheel hub worn out.	Replace wheel hub.
	Unbalance due to broken blast wheel blade.	Replace blast wheel. Check inside of machine and remove broken blade.
	Worn motor bearings or shaft.	Replace motor.
	Uneven wear of blast wheel.	Replace blast wheel.
Reduced or no performance	Uneven blast pattern.	Adjust control cage.
	Not enough shot in hopper.	Add shot.
	Insufficient shot fed to blast wheel.	Clean mesh tray. Check valve for blockage.
	Loose shaft clamp.	Tighten set screw to secure clamp to shaft.
	Valve out of adjustment.	Inspect valve for proper opening and closing.
	Too much dust in hopper.	Check dust collector filters and replace if needed. Purge more frequently. Verify CFM rating of dust collector is sufficient.
	Blast wheel or control cage is worn out.	Replace worn parts.
	Valve does not close properly.	Clear valve of debris.
	Too much shot fed when turned on.	Ensure motor reaches a steady state before opening the valve.
	Travel speed is too fast.	Reduce travel speed to achieve desired profile.
	Dropping shot	Too much dust in shot hopper.
Concrete is too soft, building up too much dust in hopper.		
Separator cover is not sealed.		Check cover seal for air leaks. Adjust cover position or replace seal.
Shot hopper is over-filled.		Remove excess shot to level just below the mesh tray.
Magnet height out of adjustment.		Verify the magnet height is not above .32" (8 mm).
Control cage not rotated correctly.		Adjust control cage to achieve even blast pattern.
Blast wheel worn.		Replace blast wheel.
Liners worn.		Replace liners.
Magnets lost field.	Replace magnets.	
Losing shot	Shot being sucked out of vacuum port.	Use a smaller dust collector or reduce suction and flow.

Troubleshooting Guide

GENERAL (CONT'D)

Problem	Cause	Solution
Too much dust present	Insufficient air flow towards dust collector.	Verify CFM rating of the dust collector is sufficient.
		Check all seals and dust hoses.
		Check dust collector filters and replace if needed. Purge more frequently.

ELECTRICAL

Problem	Cause	Solution
Blast wheel motor does not start. Blast wheel motor stops during operation.	Emergency stop is depressed.	Release emergency stop button.
	Circuit breaker tripped.	Make sure dust collector and shot blaster are connected on separate circuits.
		Make sure you are using an appropriately sized circuit for the amperage requirements.
		Reset the amperage to factory spec.
		Check for blast wheel obstruction.
		Reset circuit breaker.
	Ground fault related failure.	Ensure ground fault protection device is functioning properly.
	Cord unplugged.	Plug in cord.
	Wires damaged.	Check wires, replace if needed.
	Faulty switch or relays.	Contact Discount-equipment for service.
Motor damaged.	Contact Discount-equipment for service.	

Maintenance Schedule



WARNING: BEFORE PERFORMING MAINTENANCE, ALWAYS DISCONNECT THE MACHINE FROM POWER TO PREVENT ACCIDENTAL START-UP.

MAINTENANCE AND INSPECTION LIST

Operating Hours/Time Period	Inspection Points and Maintenance Instructions
1-12 hours after repairing	<ul style="list-style-type: none"> • Ensure all safety devices are functioning properly. • Check that all accessible fasteners are tight.
Before, during, and after operation	<ul style="list-style-type: none"> • Check for any foreign matter in the hopper, feed spout or the blast wheel. • Check the amount of shot in the hopper. Refill if necessary.
Daily and prior to starting work	<ul style="list-style-type: none"> • Check the hose connection for tightness and fixed seals. • Check dust hose and filter for damage. • Ensure dust collector has been emptied. • Check blast wheel, feed spout, liners, and fasteners for wear and damage. • Check the separator parts for wear and damage. • Remove foreign parts and dust deposits. • Check magnets and brushes for wear. • Check the electrical connections for dirt and contaminants. • Check the electrical motor for dirt and other contaminants.
Annually	<ul style="list-style-type: none"> • Full overhaul and cleaning of the machine.

MAINTENANCE INTERVALS

Inspections Interval	Part	Sign of Wear	Repairing Action
10-20 hours	Brushes	Wear at the lower end	Readjust brushes flush with floor or replace if needed.
30-40 hours	Blast wheel and control cage	Blades of the blast wheel are worn 1/3, deep groves	Replace blast wheel and control cage.
50 hours	Liners	Side liners loose from wear reaching threaded stud	Replace liners.
100 hours	Rebound plate in the separator	Significant wear of the rebound plate	Replace separator.
200 hours	Feed spout	Cracked or worn-out feed spout	Replace feed spout.
	Rear wheels	Out of grease.	Grease wheels.

Maintenance



WARNING: BEFORE PERFORMING MAINTENANCE, ALWAYS DISCONNECT THE MACHINE FROM POWER TO PREVENT ACCIDENTAL STARTUP.

REMOVING THE BLAST WHEEL (FIGURE 1-2)

1. Remove feed spout (1) by pulling it out of the housing.
2. Loosen the control cage clamps (2).
3. Remove the control cage (3).
4. Remove the nuts (4) of the front plate (5) and remove the plate.
5. Fix the blast wheel (7) from rotating by pressing the shaft-locking button on motor (Figure 7).
6. Remove the blast wheel nut (6).
7. Remove the blast wheel (7).
8. Remove the wheel hub (8) and inspect for wear.
9. Inspect the seal (9) for wear.

INSTALLING THE BLAST WHEEL (FIGURE 1-2)

1. Replace seal (9) if it is worn.
2. Place wheel hub (8) on motor shaft making sure it is properly aligned and fully seated.
3. Place blast wheel (7) through the housing opening and onto the wheel hub (8) aligning with the pins of the hub. Spin wheel to ensure it is properly seated on the pins and doesn't wobble.
4. Clean threads of motor shaft and blast wheel nut (6) removing any shot.
5. Fix the blast wheel (7) from rotating by pressing the shaft-locking button on motor (Figure 7).
6. Tighten the blast wheel nut (6) to secure the blast wheel. Spin wheel to ensure it doesn't wobble.
7. Reattach the front plate (5) with the nuts (4). Spin blast wheel to ensure it doesn't wobble.
8. Install the control cage (3). Spin blast wheel and listen for any grinding noises.
9. Tighten the cage clamps (2) to secure the control cage (3). Make sure the blast wheel can rotate freely.
10. Install the feed spout (1).
11. Adjust the control cage (3) to achieve an even blast pattern.

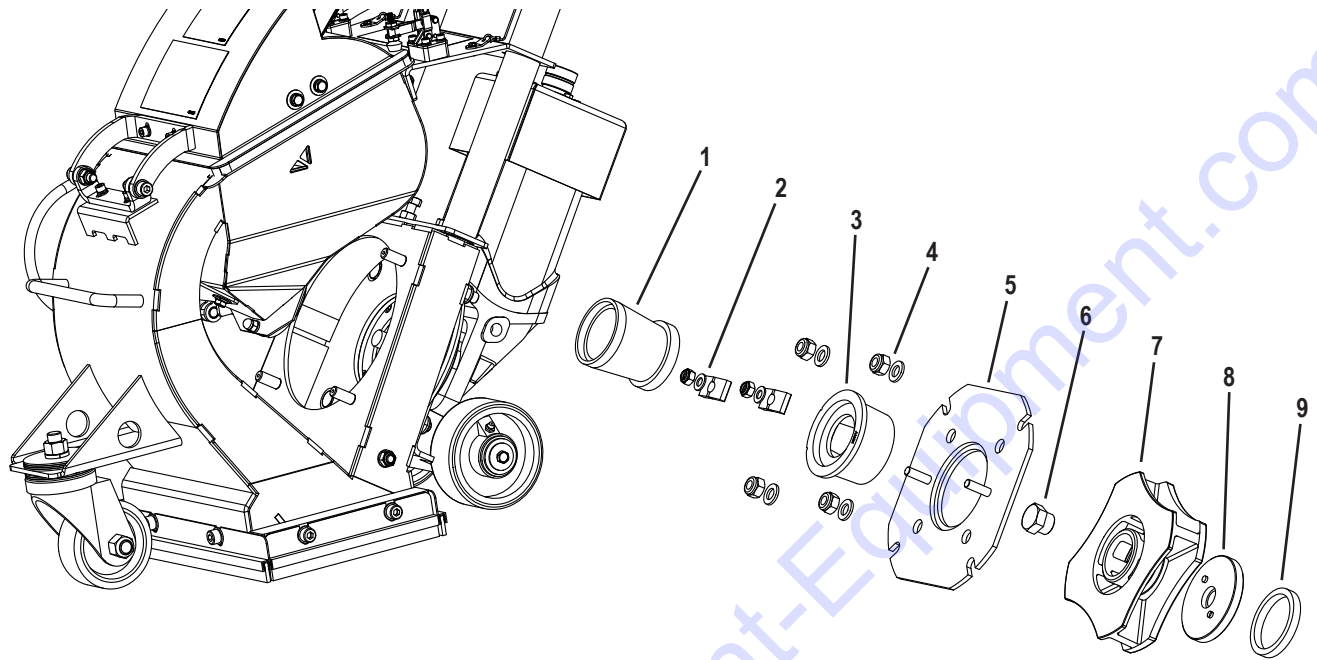

FIG. 1

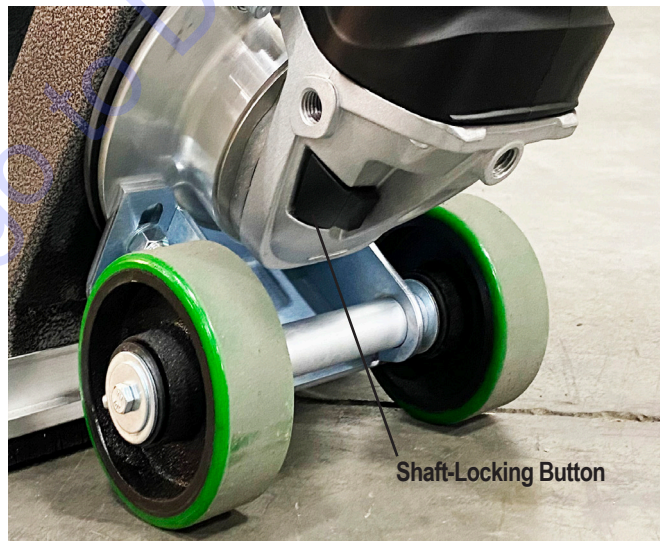

FIG. 2

Maintenance



WARNING: BEFORE PERFORMING MAINTENANCE, ALWAYS DISCONNECT THE MACHINE FROM POWER TO PREVENT ACCIDENTAL STARTUP.

REMOVING THE LINERS (FIGURE 3)

1. Before removing liners, remove the blast wheel and wheel hub for easier liner removal and replacement.
2. Lay the machine down on its back exposing the underside of the machine.
3. Loosen the fastening nuts of the left hand (1) and right hand (2) liners.
4. Turn the liners toward the inside of the blast housing and remove them through the bottom opening of the housing.
5. Tighten the pressure screw (4) against the top liner (3) and tighten it down completely.
6. Loosen the pressure screw (4) and remove it.
7. Insert a punch through the thread opening and tap until the top liner (3) slides out.
8. Turn the top liner around the motor shaft and remove it through the bottom opening of the housing.

INSTALLING THE LINERS (FIGURE 3)

1. Lay the machine down on its back exposing the underside of the machine.
2. Before installing new liners, check the wheel housing and its corners for wear.
3. Install the pressure screw (4) for the top liner (3).
4. Insert the top liner (3) through the bottom and rotate it around the motor shaft into the upper part of the housing.
5. Place the side liners (1 & 2) in the housing, so the threaded studs can be pushed through the holes in the side of the housing.
6. Thread the nuts onto the studs and tighten them slightly.
7. Position the side liners (1 & 2) so the liners stick out at the bottom of the housing approximately .09" (2 mm).
8. Tighten the side liner nuts.
9. Tighten the pressure screw (4) until the edges of the top liner (3) are in contact with the upper edges of the side liners (1 & 2).
10. Reinstall the blast wheel and wheel hub.
11. Adjust the control cage to achieve an even blast pattern.

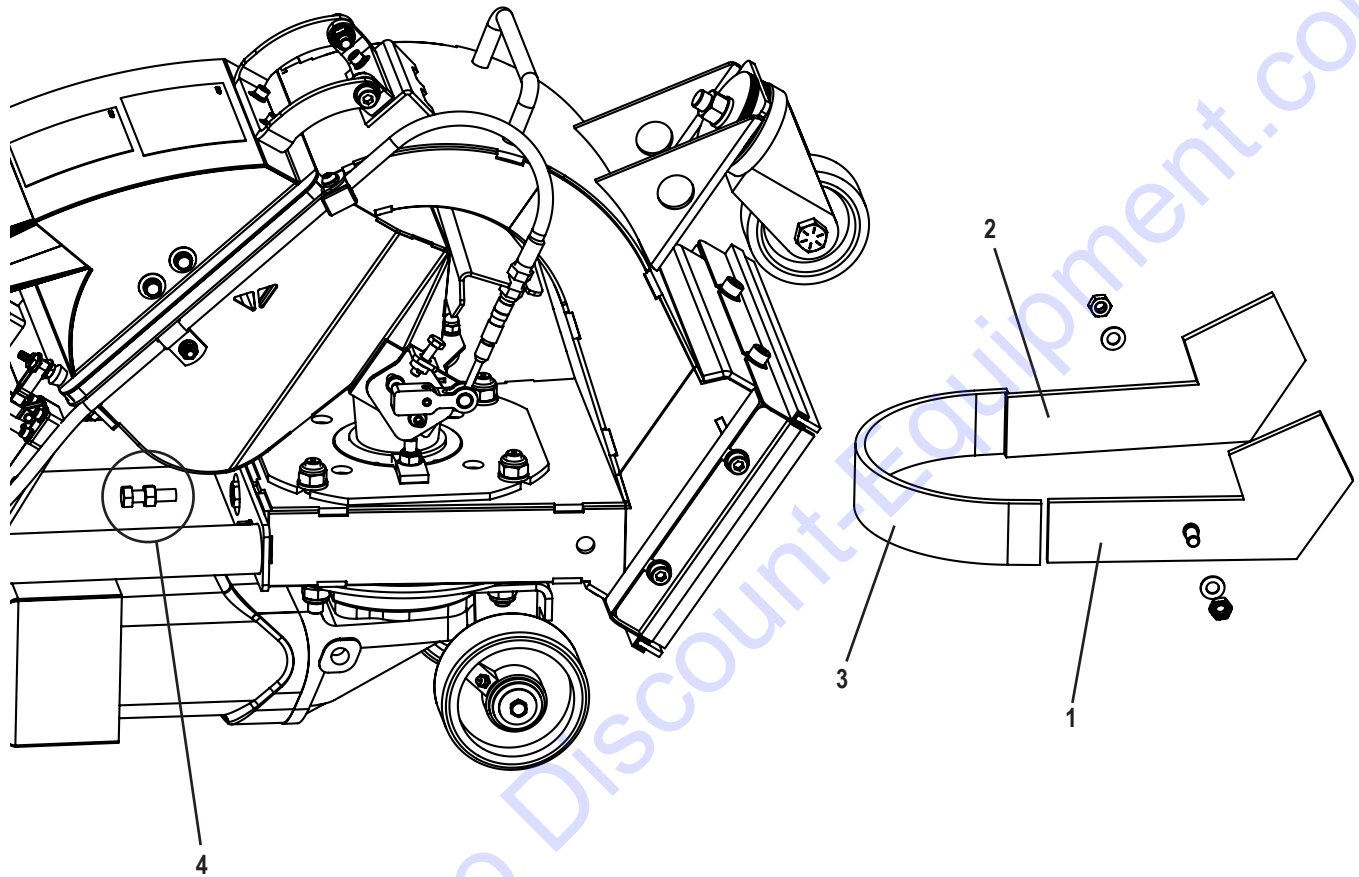

FIG. 3

Maintenance



WARNING: BEFORE PERFORMING MAINTENANCE, ALWAYS DISCONNECT THE MACHINE FROM POWER TO PREVENT ACCIDENTAL STARTUP.

ADJUSTING SEPARATOR COVER (FIGURES 4-5)

The correct adjustment of the separator cover is important for creating a good seal between the cover and the hopper.

1. Loosen screws (1) to adjust separator cover to hopper opening.
2. Loosen screws (2) to adjust the compression of the separator cover gasket to .28" (7 mm).

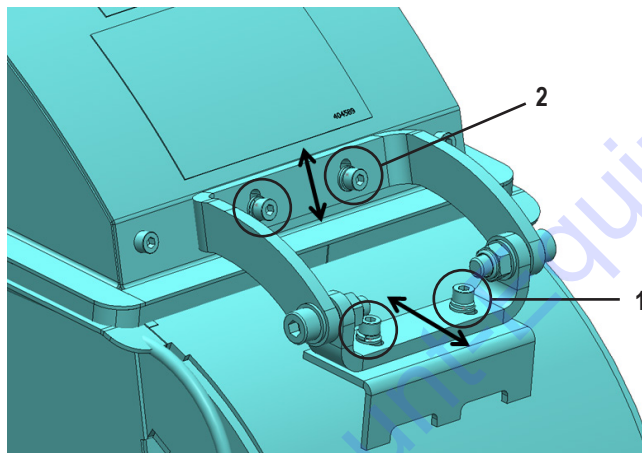

FIG. 4

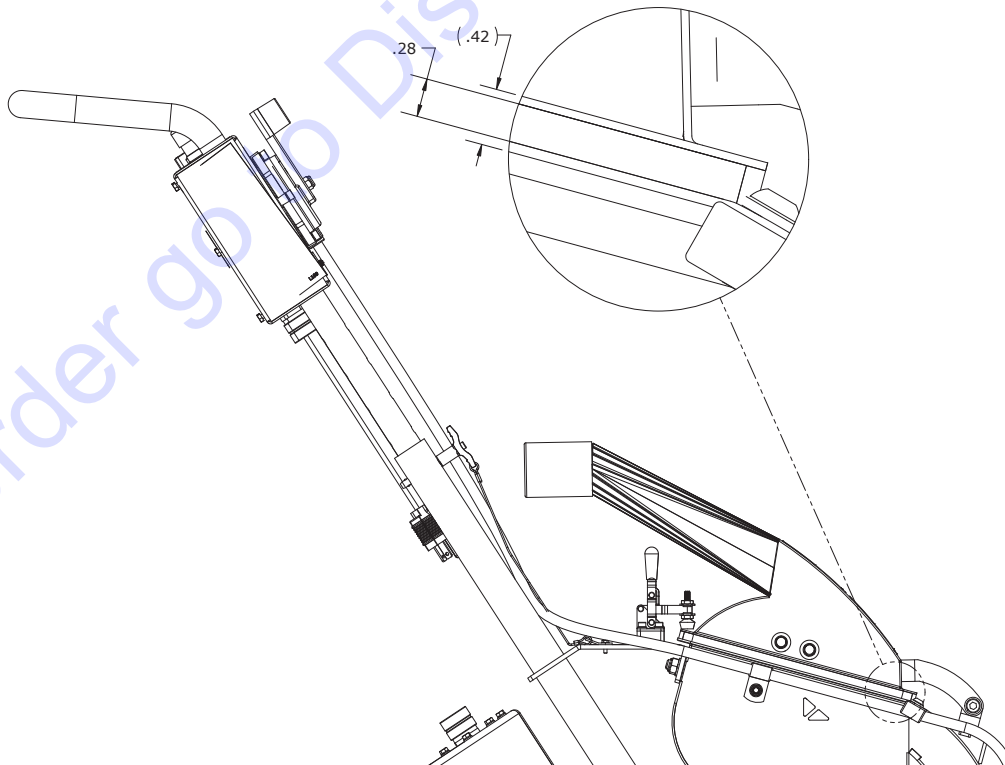

FIG. 5



WARNING: BEFORE PERFORMING MAINTENANCE, ALWAYS DISCONNECT THE MACHINE FROM POWER TO PREVENT ACCIDENTAL STARTUP.

REMOVING THE SHOT VALVE CONTROL CABLE (FIGURE 6)

1. Remove shot from hopper.
2. Loosen the two adjustment nuts (1) to loosen cable from bracket.
3. Loosen set screw on linkage (2) and slide linkage from shaft.
4. Unscrew swivel (3) from cable (4).
5. Remove shot control lever from front of control box.

INSTALLING THE SHOT VALVE CONTROL CABLE (FIGURE 6-7)

1. Replace shot control lever onto front of control box.
2. With swivel (3) inserted into linkage (2), thread the swivel completely onto cable (4) so swivel bottoms out.
3. Slide cable into bracket. Do not tighten the adjustment nuts (1) at this time.
4. Slide linkage (2) onto shaft and tighten set screw on flat of shaft. Linkage should be flush with end of shaft.
5. Close the shot valve by moving the shot control lever to the closed position.
6. Hand tighten the adjustment nuts (1) making sure that the shot valve flap (5) is fully closed.
7. Move shot control lever back and forth several times verifying the shot valve opens and closes.
8. Tighten the adjustment nuts (1) so the cable is secured to the bracket.
9. Set the amperage. See *Setting the Amperage* procedure.

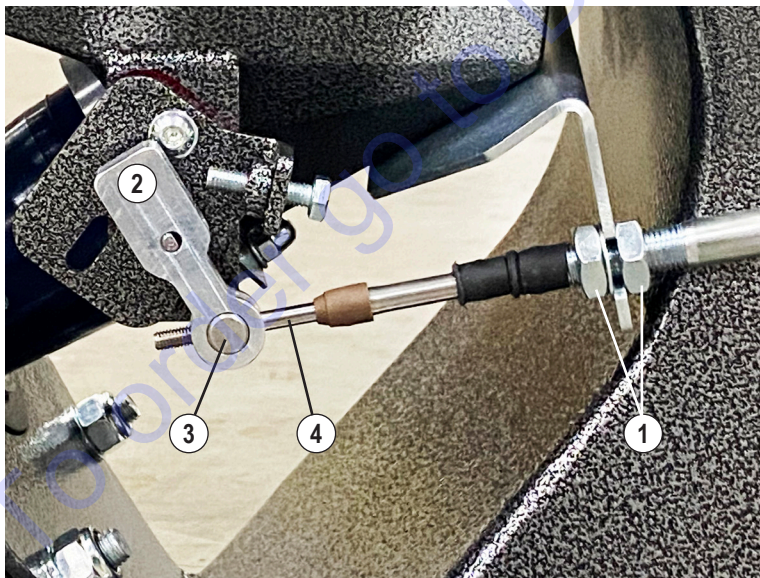

FIG. 6

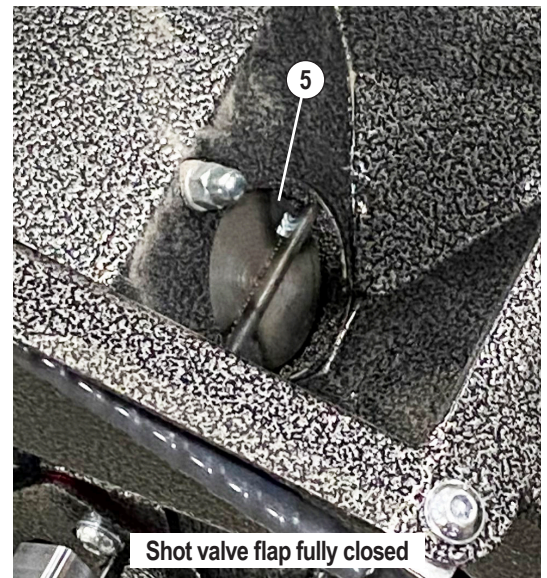

FIG. 7

Shot valve flap fully closed

Maintenance

SETTING THE AMPERAGE (FIGURE 8)

The amperage must be set whenever the shot valve control cable has been damaged or replaced.

1. Move machine to an area where blasting can be performed.
2. Start the machine following the *Preparing for Operation* and *Start-Up Procedure* sections in the operating manual.
3. Once the blast wheel motor has reached a steady state and machine is moving forward, slowly open the shot valve while watching the ammeter. The ammeter reading will increase as the shot valve is opened.
4. Continue to slowly open the shot valve until the ammeter reading matches the maximum operating amps (indicated on label located near ammeter). STOP OPENING THE SHOT VALVE IMMEDIATELY WHEN THE MAXIMUM OPERATING AMPS IS REACHED—DO NOT EXCEED THE MAXIMUM OPERATING AMPS!
5. The shot valve stop must be adjusted to stop the valve at the maximum operating amps. Do NOT adjust at this time.
Note: *If the shot valve already stops at the maximum operating amps, then no adjustment is needed.*
6. Stop the machine following the *Turning Off the Machine* procedure in the operating manual.
7. Adjust the shot valve stop. Turning CW decreases amps, CCW increases amps. Adjust in fine increments.
 - If the maximum operating amps is reached before the shot valve stops, turn the stop CW to close the valve slightly.
 - If the shot valve stops before the maximum operating amps is reached, turn the stop CCW to open the valve slightly.
8. Repeat Steps 2-7 until the shot valve stop is adjusted properly—this may take several attempts. The stop is adjusted properly when the shot valve stops at the maximum operating amps.



FIG. 8

RECOMMENDED SPARE PARTS LIST

To avoid downtime, NFE recommends keeping the following spare parts in stock. NFE offers a maintenance kit (Part# A95KIT) which contains the indicated parts as well as tools needed for some maintenance work.

Part Number	Description	Quantity	Included in Kit?
404330	Service Kit, Blast Wheel, 20mm x 165mm, NFE	1	Yes
400409	Liner, Left (Weldment)	1	Yes
400410	Liner, Right (Weldment)	1	Yes
400457	Brush, Front/Rear	2	Yes
400458	Brush, Side	2	Yes
400473	Liner, Top	1	Yes
400413*	Cable, Valve Control	1	Yes
403623	Nut, Hex, Retaining, 5/8-11 (A95-10XXXX, -20XXXX, -23XXXX ONLY)	1	No
400532	Nut, Blast Wheel, M14 x 2.0 (A95-11XXXX ONLY)	1	No
400575	Seal, Drive Motor, Felt	1	No

* The included cable fits the older version of the machine. If the cable does not match the one on your machine it can be discarded. If the cable matches the one on your machine, contact Discount-equipment for the replacement procedure.

Parts List and Diagrams

OVERALL

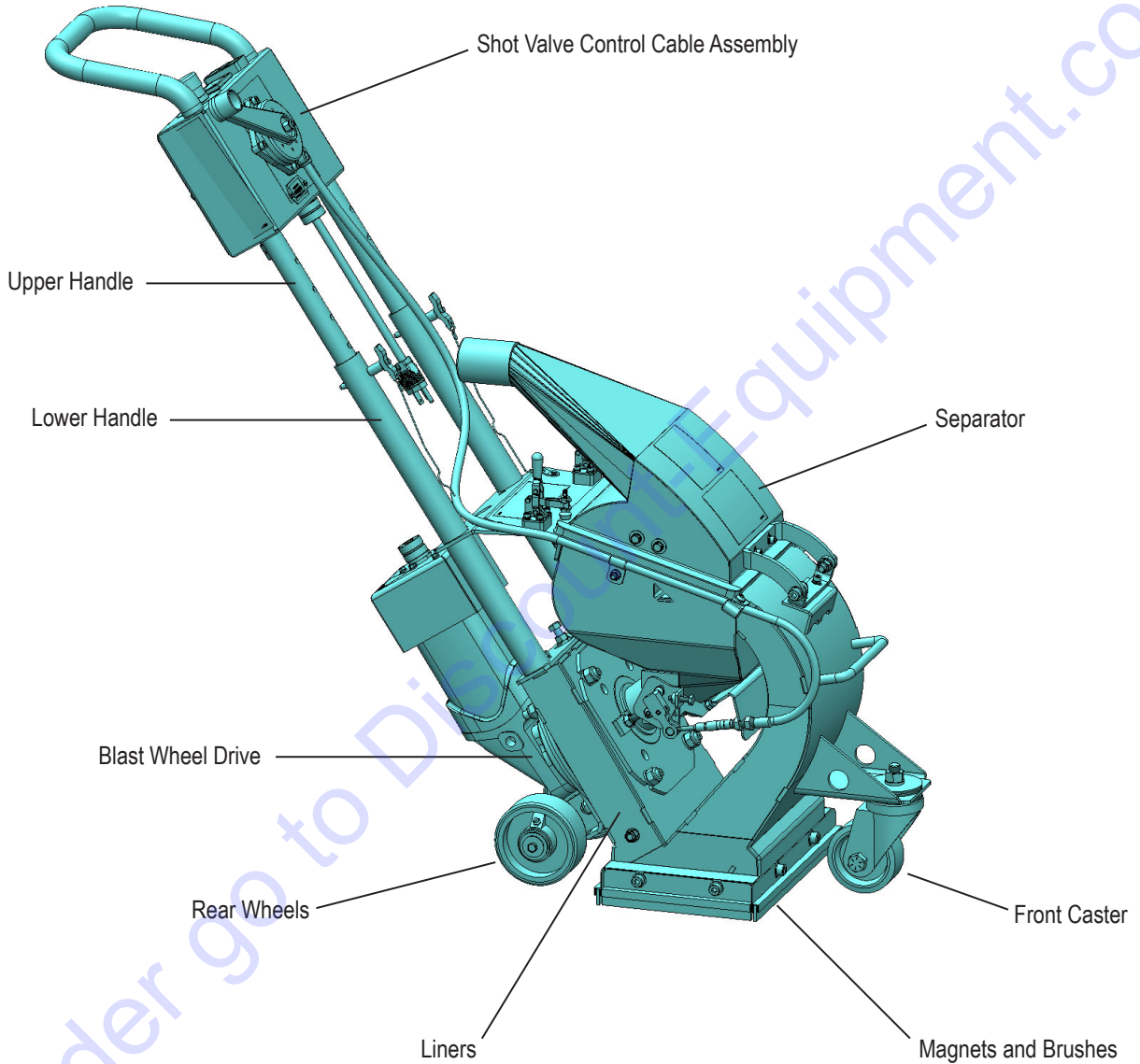

Parts List and Diagrams

SHOT VALVE CONTROL CABLE ASSEMBLY

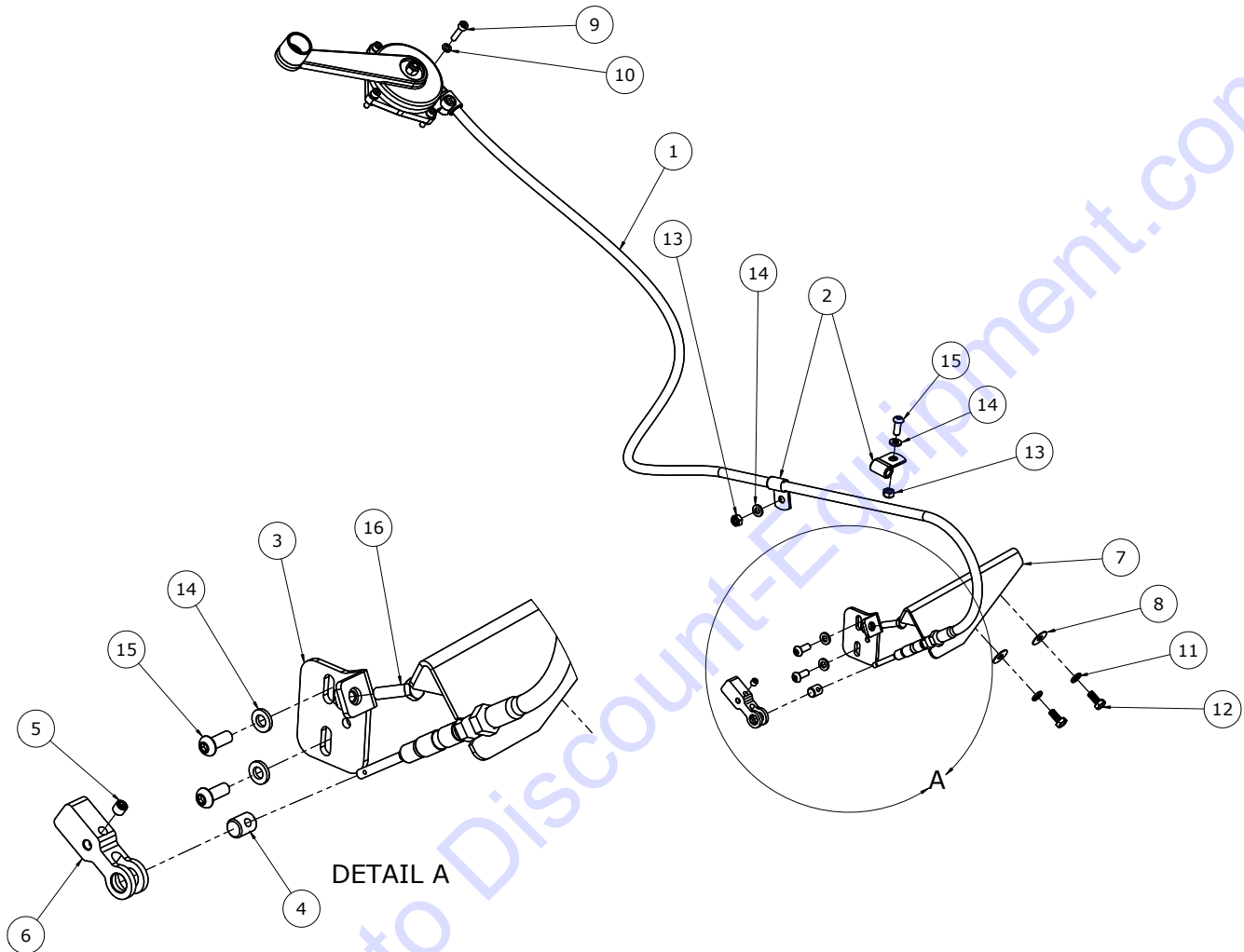

ITEM#	PART#	DESCRIPTION	QTY
1	406650	Cable, 48" Long, w/lever	1
2	72837	Clamp, Cable, Vinyl Coated, 5/16	2
3	404831-SV	Assy Plate, Adjust, Feed Valve	1
4	404430	Swivel, Feed Valve	1
5	404850	Screw, Set, Flat, M6x1.0 x 6mm Long	1
6	404427	Linkage, Shaft, Feed Valve	1
7	406642	Bracket, Feed Valve Cable	1
8	401328	Washer, Flat, Fender, M6, Clear Zinc	2
9	403280	Screw, Socket Head Cap, M5-0.8 x 20, Black Oxide	4
10	401331	Washer, Lock, M5, Clear Zinc	4
11	74619	Washer, Lock, M6	2
12	401312	Screw, Hex Head Cap, M6-1.0 x 14, Clear Zinc	2
13	401516	Nut, Hex, Nylon Insert, M6-1.0, Clear Zinc	2
14	405486	Washer, Flat, M6, Clear Zinc	4
15	405262	Screw, Button Head Cap, M6x1.0 x 16, Clear Zinc	3
16	401660	Screw, Hex Head Cap, M6-1.0 x 25, Class 8.8, Clear Zinc	1

Parts List and Diagrams

SEPARATOR

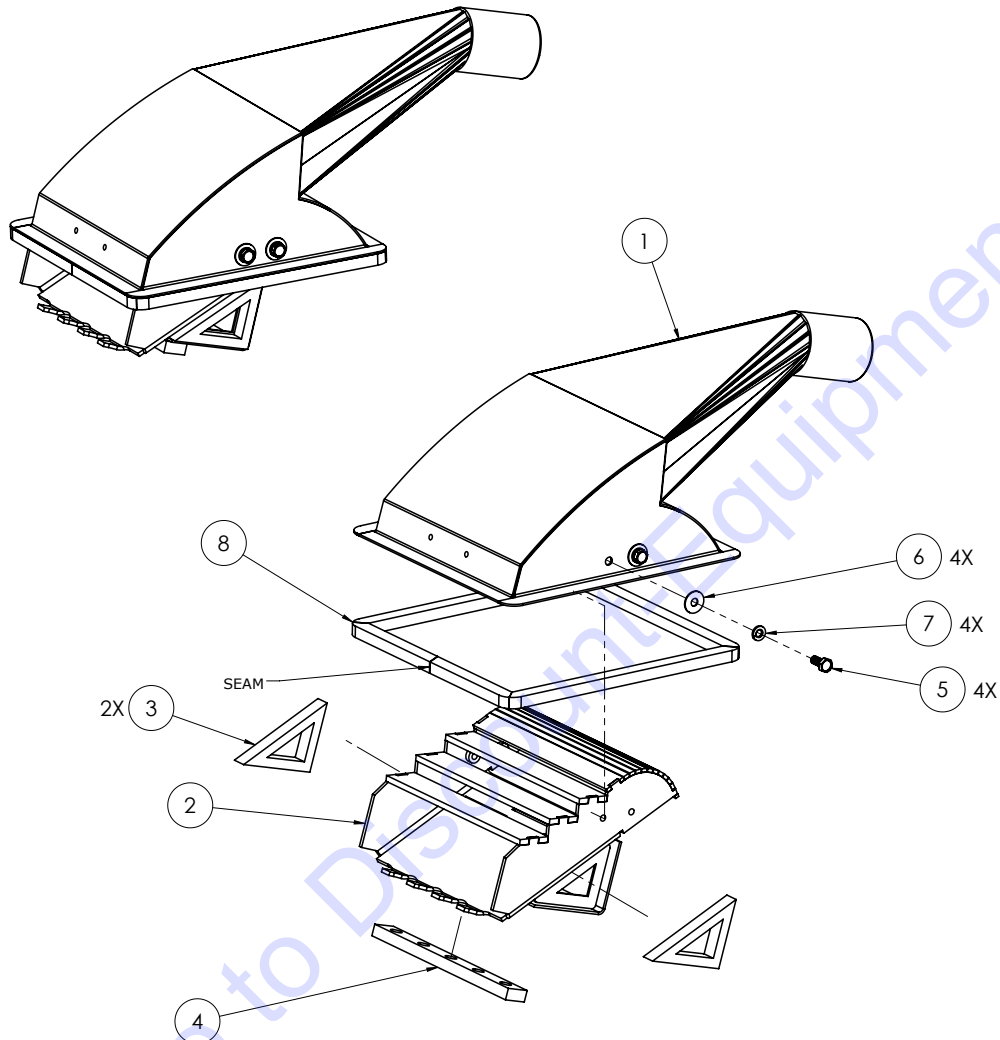

ITEM#	PART#	DESCRIPTION	QTY
1	400406	Weldment, Separator Cover	1
2	400407	Weldment, Separator	1
3	400447	Seal, Separator	2
4	400606	Gasket, Separator	1
5	401312	Screw, Hex Head Cap, M6-1.0 x 14, Clear Zinc	4
6	401328	Washer, Fender, M6, Clear Zinc	4
7	74619	Washer, Lock, M6	4
8	404196	Gasket, Seal, Separator Cover	1

Parts List and Diagrams

SEPARATOR (CONT'D)

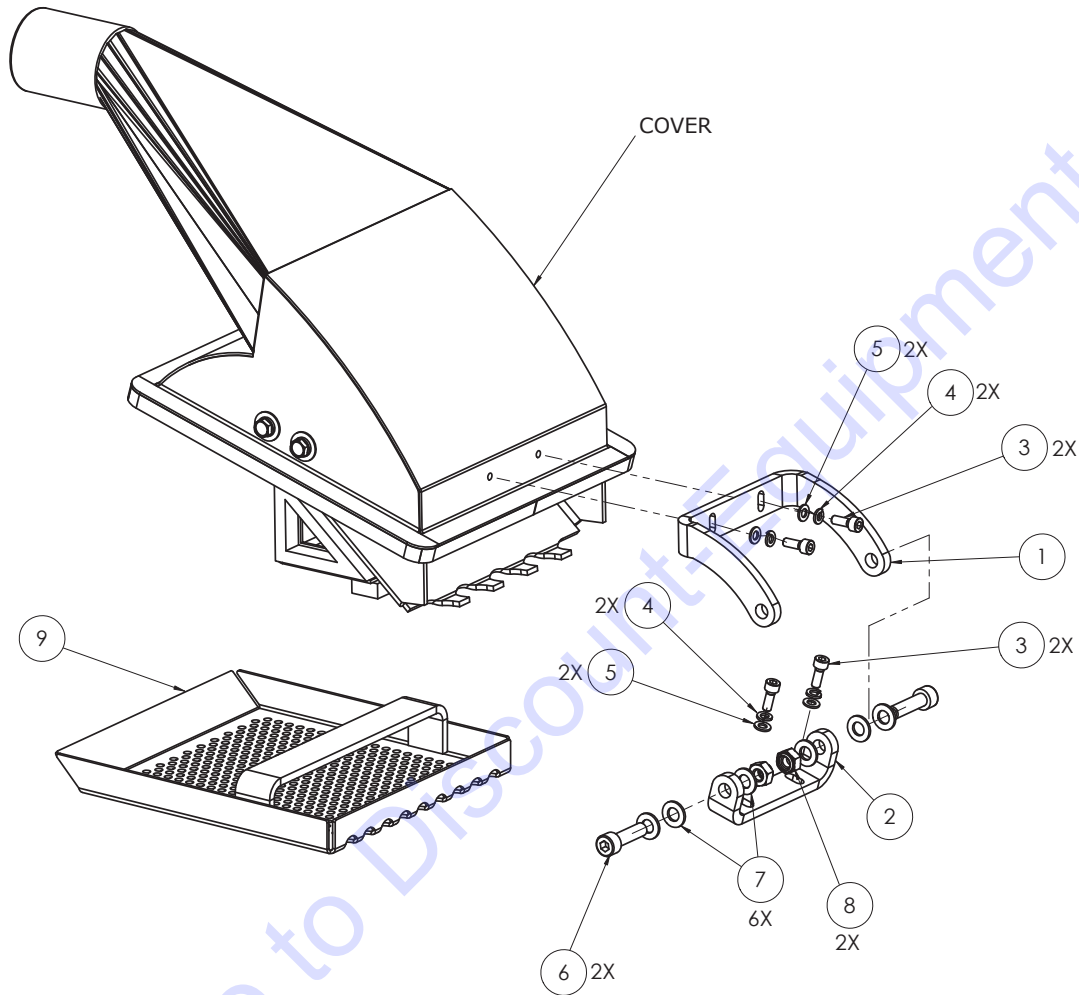

ITEM#	PART#	DESCRIPTION	QTY
1	404193	Plate, Hinge, Hopper Cover	1
2	404194	Plate, Hinge, Chute	1
3	401320	Screw, Socket Head Cap, M5-0.8x14, Black Oxide	4
4	401331	Washer, Lock, M5, Clear Zinc	4
5	401327	Washer, Flat, M5, Clear Zinc	4
6	404329	Screw, Socket Head Cap, M8 x 1.25 x 30, Black Oxide	2
7	401329	Washer, Flat, M8, Stainless Steel	6
8	401509	Nut, Hex, Nylon Insert, M8-1.25, Clear Zinc	2
9	404289	Weldment, Hopper Tray	1

Parts List and Diagrams

BLAST WHEEL DRIVE

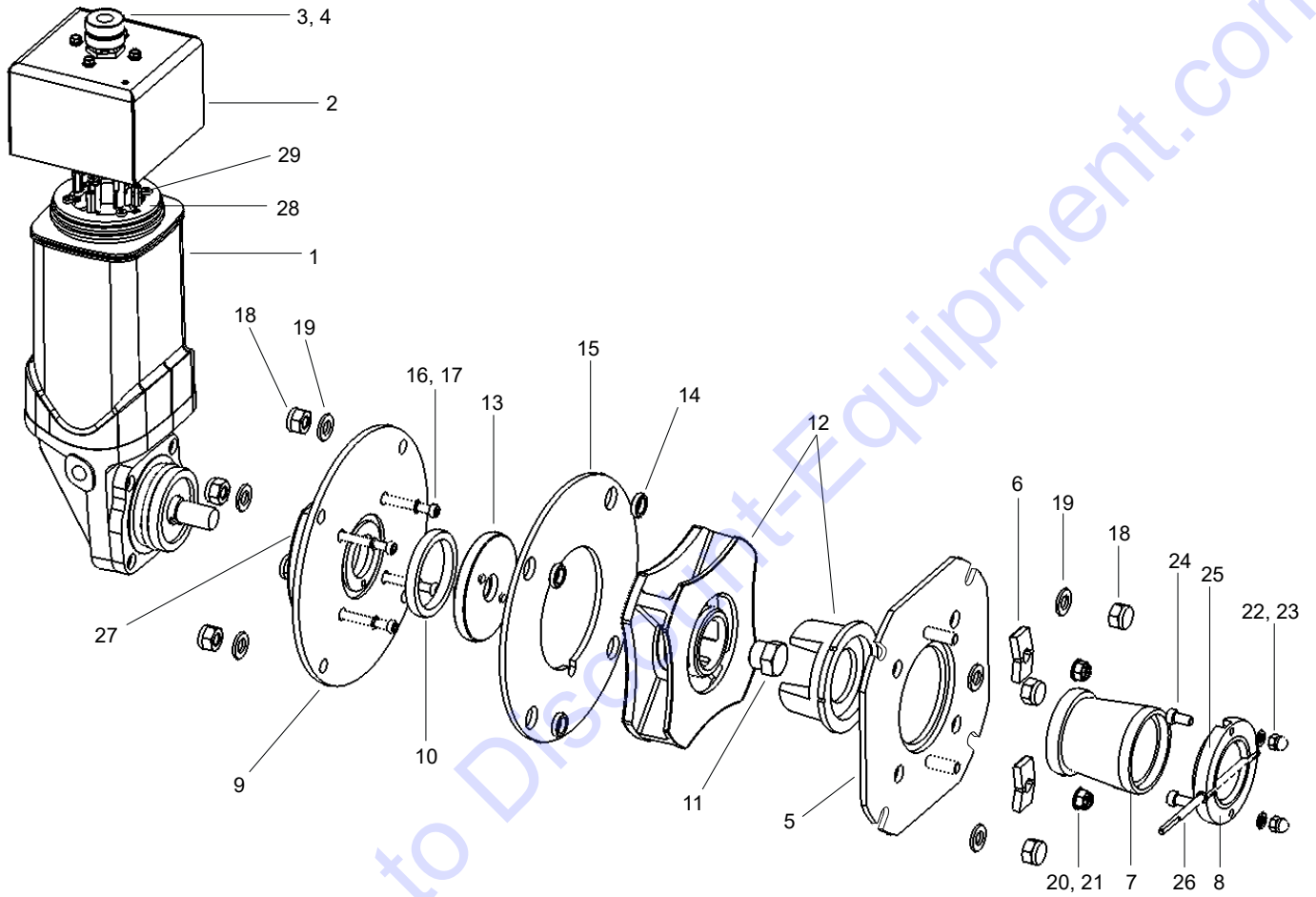

Parts List and Diagrams

BLAST WHEEL DRIVE (CONT'D)

ITEM#	PART#	DESCRIPTION	QTY
1	403622	Assembly, Drive Motor, 120V, 5/8-11 Spindle	1
	402221	Assembly, Drive Motor, 240V (A95-11XXXX Only)	1
2	400573	Cover, Motor Guard	1
3	72804	Strain Relief, Straight, 1/2" NPT, .38"-.50" ID	1
4	73401	Locknut, Conduit, 1/2"	1
5	404593	Plate, Control Cage	1
6	400536	Clamp, Control Cage	2
7	400496	Spout, Shot Feed	1
8	400464	Spacer, Magnet	1
9	400574	Plate, Motor Support	1
10	400575	Seal, Drive Motor, Felt	1
11	403623	Nut, Hex, Retaining, 5/8-11	1
	400532	Nut, Blast Wheel, M14 x 2.0 (A95-11XXXX Only)	1
12	404330	Service Kit, Blast Wheel, 20mm x 165mm, NFE	1
13	403625	Hub, Blast Wheel, 5/8 ID	1
	400425	Hub, Blast Wheel, 9/16 Bore (A95-11XXXX Only)	1
14	400487	Spacer, Seal	4
15	400486	Seal, Ring	1
16	403764	Screw, Socket Head Cap, M5-0.8x45, Black Oxide	4
17	401331	Washer, Lock, M5, Clear Zinc	4
18	402240	Nut, Hex, Nylon Insert, M10-1.5, Heavy, Clear Zinc	8
19	74655	Washer, Flat, M10	8
20	401509	Nut, Hex, Nylon Insert, M8-1.25, Clear Zinc	2
21	401329	Washer, Flat, M8, Stainless Steel	2
22	74619	Washer, Lock, M6	2
23	401300	Nut, Acorn, M6-1.0, Clear Zinc	2
24	401322	Screw, Socket Head Cap, M6-1.0x14, Black Oxide	2
25	400412	Valve, Magnetic, Assembly	1
26	400607	Flapper, Valve	1
27	400570	Spacer, Drive Motor	1
28	400589	Brkt, Motor Guard Mtg	1
29	400590	Standoff, Metric	4

Parts List and Diagrams

LINERS

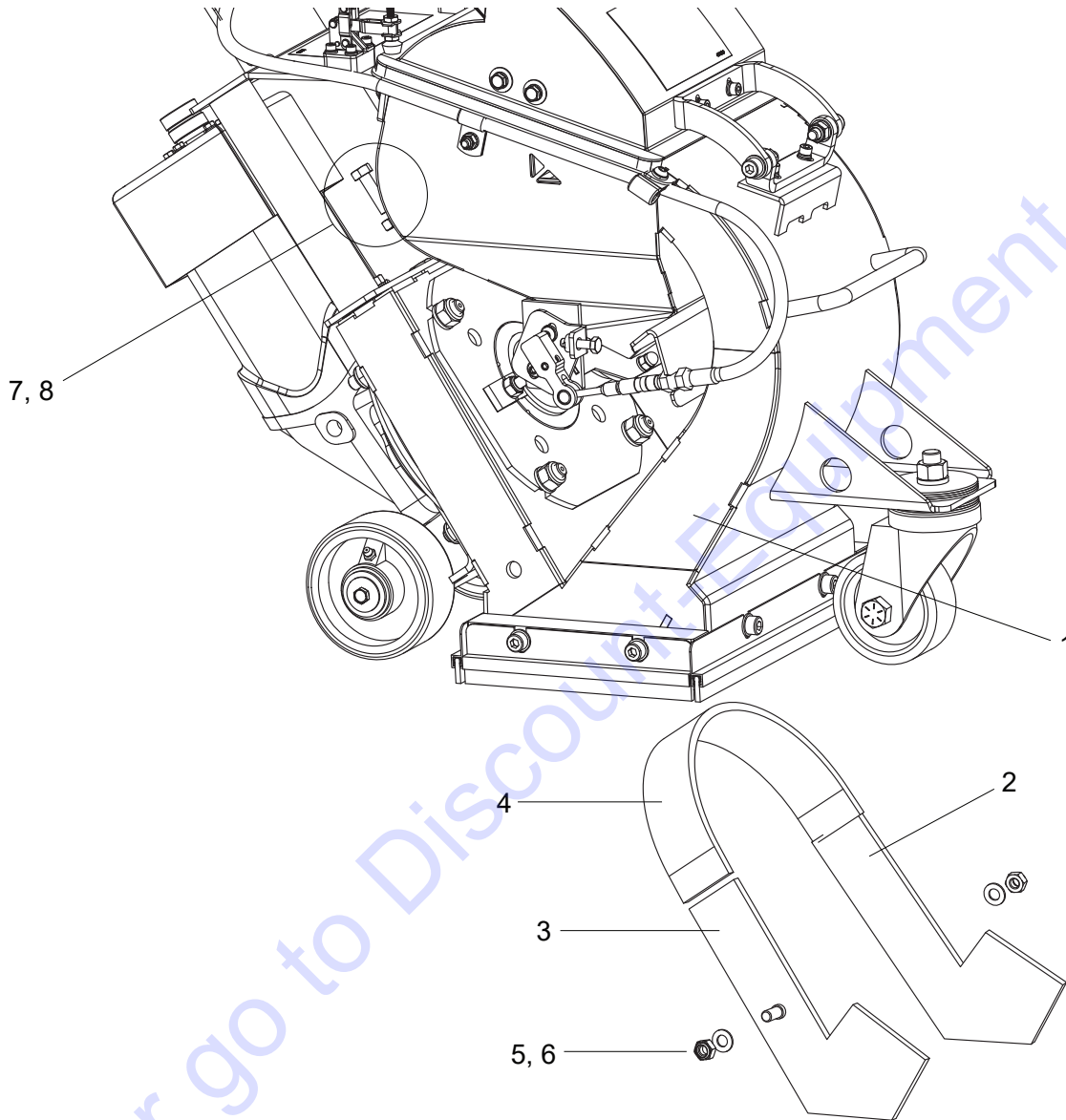

ITEM#	PART#	DESCRIPTION	QTY
1	400408	Weldment, Chute & Hopper	1
2	400410	Liner, Right (Weldment)	1
3	400409	Liner, Left (Weldment)	1
4	400473	Liner, Top	1
5	401509	Nut, Hex, Nylon Insert, M8-1.25, Clear Zinc	2
6	401329	Washer, Flat, M8, Stainless Steel	2
7	401316	Screw, Hex Head Cap, M8-1.25 x 30, Clear Zinc	1
8	74635	Nut, Hex, M8-1.25	1

Parts List and Diagrams

MAGNETS AND BRUSHES

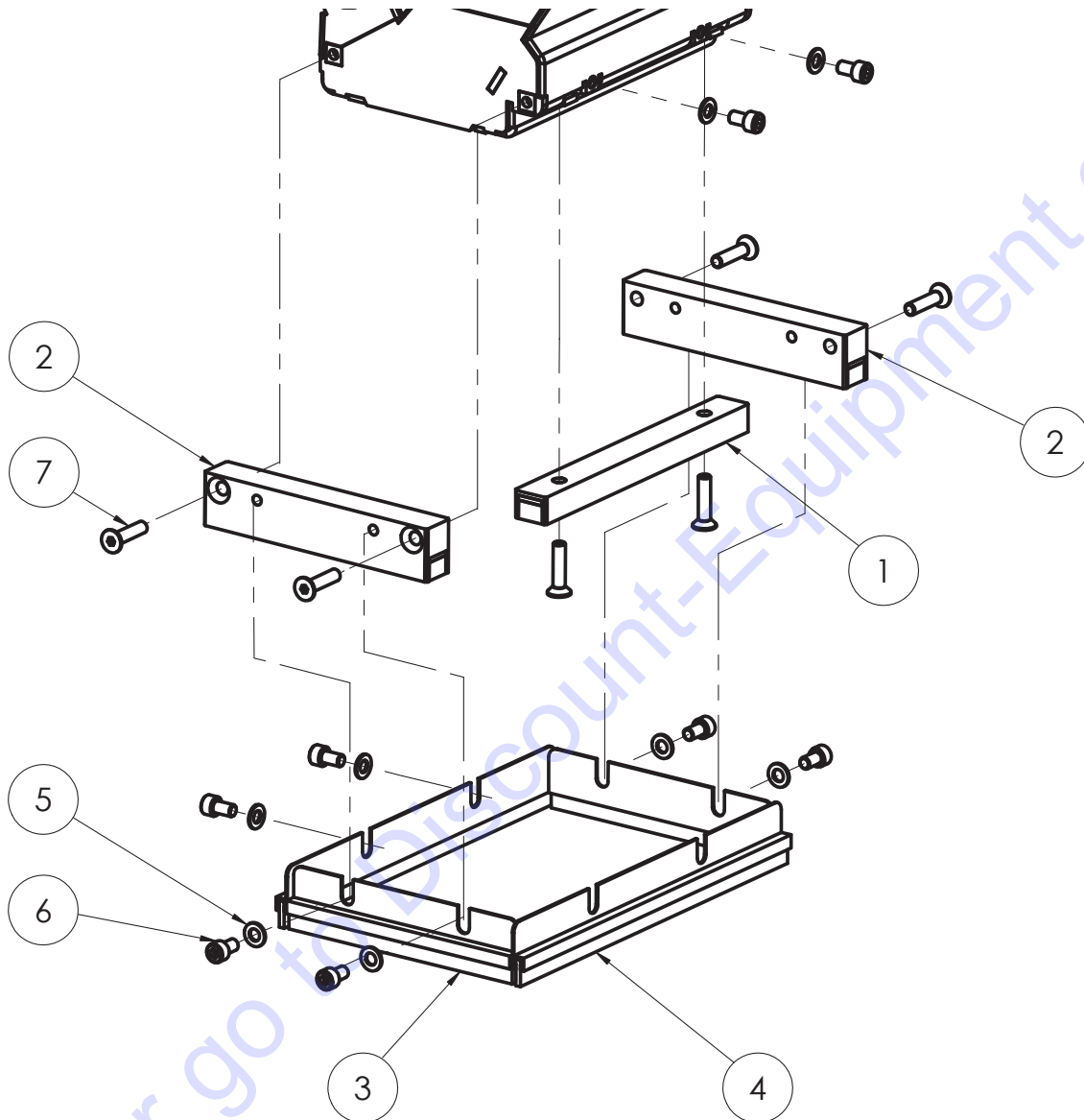

ITEM#	PART#	DESCRIPTION	QTY
1	402316	Assembly, Magnet, Front	1
2	402315	Assembly, Magnet, Side	2
3	400458	Brush, Side	2
4	400457	Brush, Front/Rear	2
5	401329	Washer, Flat, M8, Stainless Steel	8
6	401324	Screw, Socket Head Cap, M8-1.25x14, Stainless Steel	8
7	401308	Screw, Flat Head Socket Cap, M8-1.25 x 35, Stainless Steel	6

Parts List and Diagrams

UPPER HANDLE

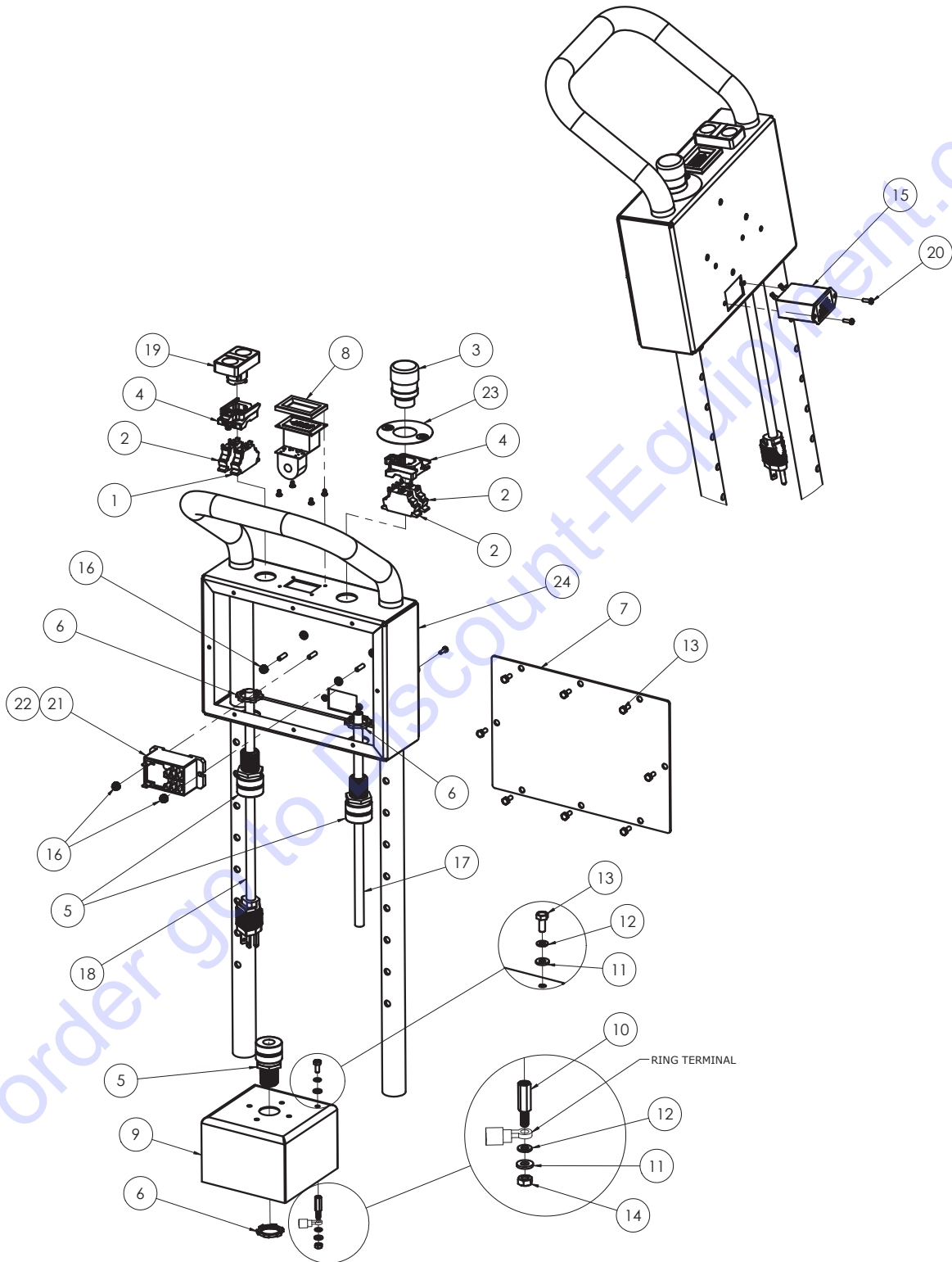

Parts List and Diagrams

UPPER HANDLE (CONT'D)

ITEM#	PART#	DESCRIPTION	QTY
1	72451	Contact Block, NO, 10A, Spring Clamp, ZB4 Series	1
2	72452	Contact Block, NC, 10A, Spring Clamp, ZB4 Series	3
3	72453	Switch, 22mm, E-Stop, ZB4 Series	1
4	72456	Collar, Mounting, 22mm, ZB4 Series	2
5	72804	Strain Relief, Straight, 1/2" NPT, .38"-.50" ID	3
6	73401	Locknut, Conduit, 1/2"	3
7	400455	Cover, Control Box	1
8	400542	Meter, Amp, AC, Digital, 20A	1
9	400573	Cover, Motor Guard	1
10	400590	Standoff, Metric	1
11	401326	Washer, Flat, M4, Clear Zinc	2
12	401330	Washer, Lock, M4, Clear Zinc	2
13	401338	Screw, Hex Head Cap, M4-0.7 x 10, Clear Zinc	9
14	401339	Nut, Hex, M4-0.7	1
15	402873	Meter, Hour, 90-264VAC, 50/60Hz	1
16	403281	Nut, Keps, M4-0.7, Clear Zinc	3
17	406692	Assy Cord, Motor, A95	1
18	406691-120	Assembly, Cord, Power, 12/3, NEMA 5-20P (A95-10XXXX, -23XXXX Only)	1
	406691-230	Assembly, Cord, Power, 2.5mm/3, EU1-16P (A95-11XXXX Only)	1
	406691-110	Assembly, Cord, Power, 2.5mm/3, IEC 309 110V (A95-20XXXX Only)	1
19	404773	Switch, 22mm, Pushbutton, Start/Stop, ZB4 Series	1
20	406177	M3-0.8 x 10 MM LG BHPH SCREW W-EXT TOOTH LOCK WASHER	2
21	406457	Relay, 30A, 120VAC, DPDT (A95-10XXXX, -20XXXX, -23XXXX Only)	1
22	406662	Relay, 30A, 230VAC, DPDT (A95-11XXXX Only)	1
23	406641	Label, E-Stop, Yellow w/Symbol	1
24	406645	Weldment, Top Handle	1
25*	406683	Kit, Wiring, A95	1

* Not shown

Parts List and Diagrams

LOWER HANDLE

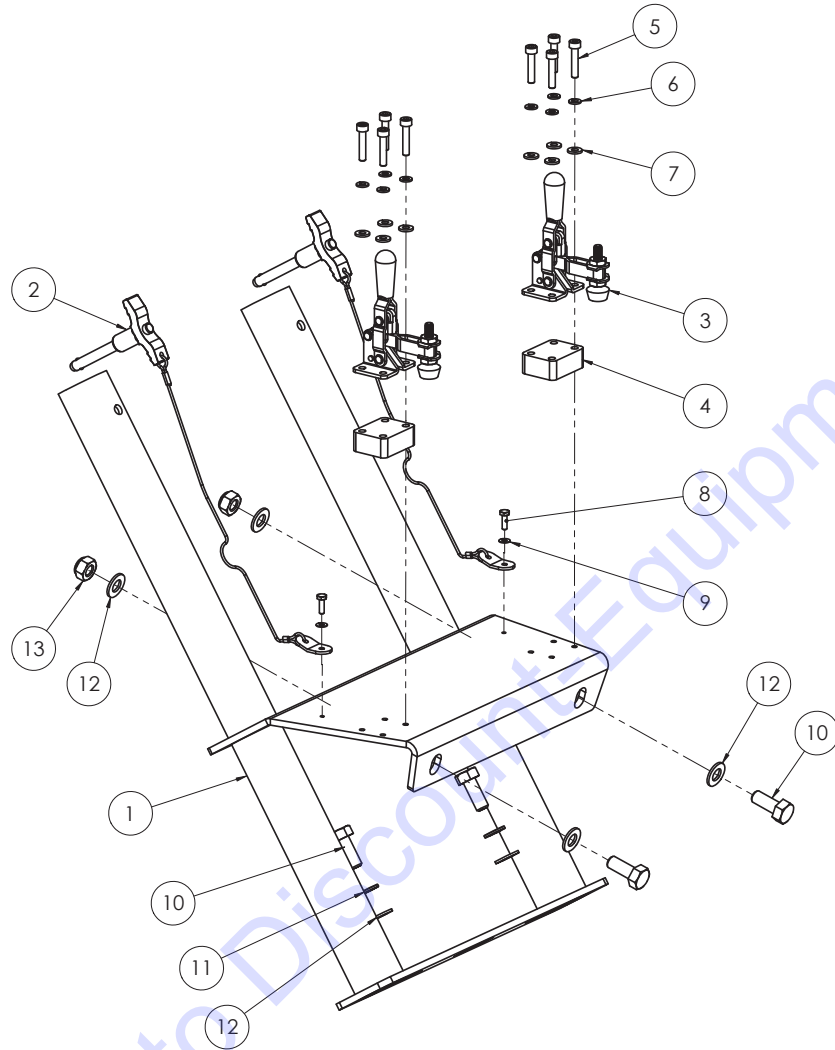

ITEM#	PART#	DESCRIPTION	QTY
1	400416	Weldment, Bottom Handle	1
2	400454	Pin, T-handle, w/tether	2
3	406654	Clamp, Hold-down, Toggle, 100lb	2
4	406656	Spacer, Separator Clamp	2
5	406655	Screw, Socket Head Cap, M4-0.7x20, Zinc	8
6	401330	Washer, Lock, M4, Clear Zinc	8
7	401326	Washer, Flat, M4, Clear Zinc	8
8	401345	Screw, Hex Head Cap, M3-0.5 x 10, Clear Zinc	2
9	401346	Washer, Flat, M3, Clear Zinc	2
10	401315	Screw, Hex Head Cap, M8-1.25 x 20, Clear Zinc	4
11	401332	Washer, Lock, M8, Clear Zinc	2
12	401329	Washer, Flat, M8, Stainless Steel	6
13	401509	Nut, Hex, Nylon Insert, M8-1.25, Clear Zinc	2

Parts List and Diagrams

REAR WHEELS AND FRONT CASTER

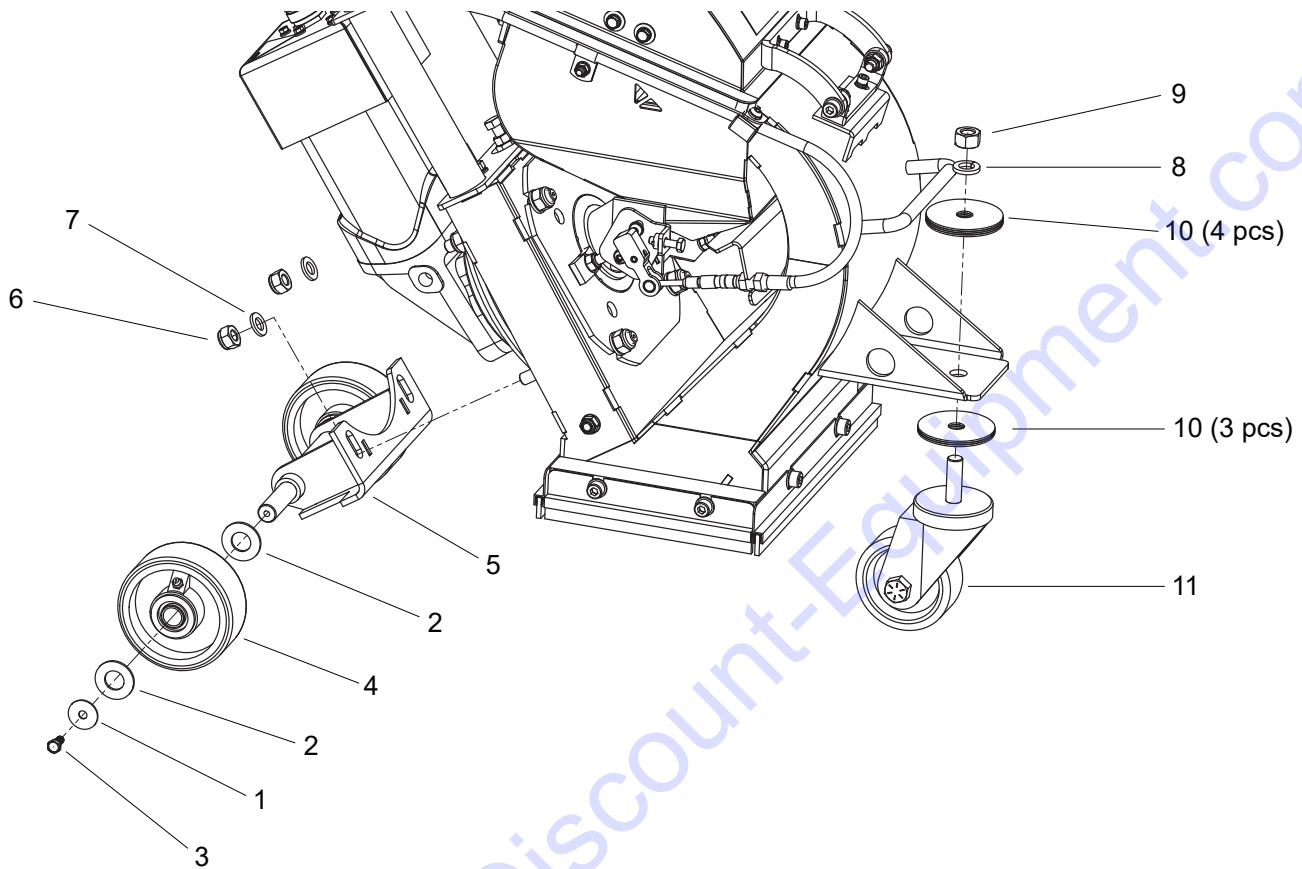

ITEM#	PART#	DESCRIPTION	QTY
1	73031	Washer, Fender, 1/4x1	2
2	73531	Washer, .656" x 1.312" x .095", Steel	4
3	401312	Screw, Hex Head Cap, M6-1.0 x 14, Clear Zinc	2
4	406632	Wheel, Roller Brg, 4" OD x .625" ID x 1.875" Hub Length	2
5	406643	Weldment, Rear Wheel Bracket	1
6	402240	Nut, Hex, Nylon Insert, M10-1.5, Heavy, Clear Zinc	2
7	74655	Washer, Flat, M10	2
8	73403	Washer, Lock, 1/2	1
9	73420	Nut, Hex, 1/2-13	1
10	406623	Washer, Fender, 1/2, 2 1/2" OD, Clear Zinc	7
11	406638	Caster, Swivel, 3.25" Dia, 1/2-13 x 1-1/2" Threaded Stem	1

Parts List and Diagrams

LABELS

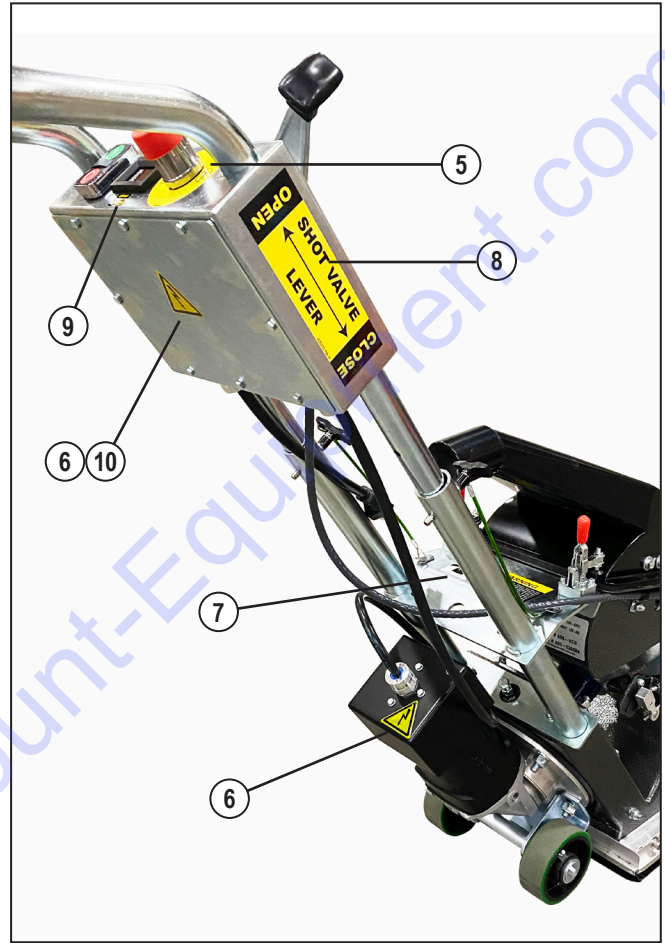
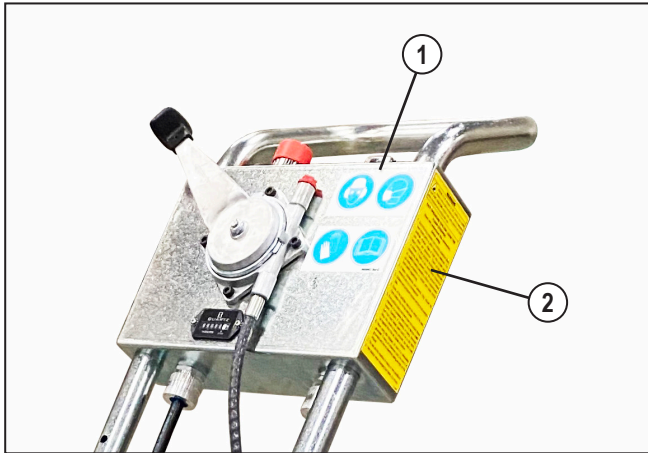

ITEM#	PART#	DESCRIPTION	QTY
1	406603	Label, ISO Pictograms	1
2	L189	Label Asbestos HD	1
3	402462	Label, National Logo, 3 x 3	1
4	404589	Label, A95	1
5	406641	Label, E-Stop, Yellow w/Symbol	1
6	400440	Label, Hazard Shock	2
7	L265	Label, Silica Dust	1
8	405203	Label, Shot Valve, 1.75 x 5.5"	1
9	404236	Label, 17A, 120V, 60Hz (A95-10XXXX, -23XXXX Only)	1
	404599	Label, 12A (A95-11XXXX Only)	1
	404598	Label, 16A (A95-20XXXX Only)	1
10	404669	Label, CE, A95, 230V, 50Hz (A95-11XXXX Only)	1
	404668	Label, CE, A95, 110V, 50Hz (A95-20XXXX Only)	1
11*	402628	Label, Private, 3.5 x 5.5 (A95-23XXXX Only)	2

* Not shown

Wiring Diagrams

**WD
PG 1**

HANDLE WIRING DIAGRAM

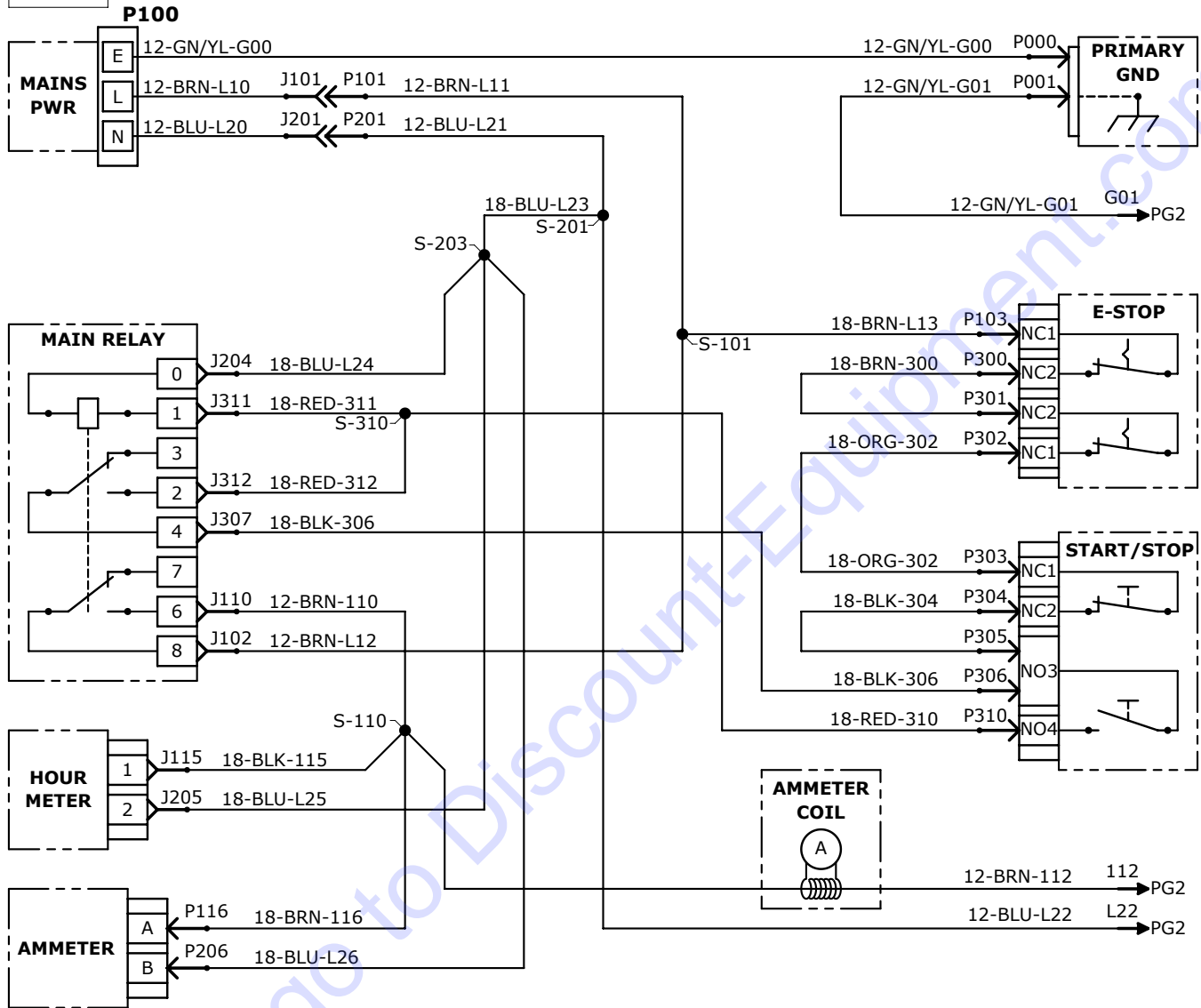

Wiring Diagrams

BLAST MOTOR WIRING DIAGRAM

WD
PG 2

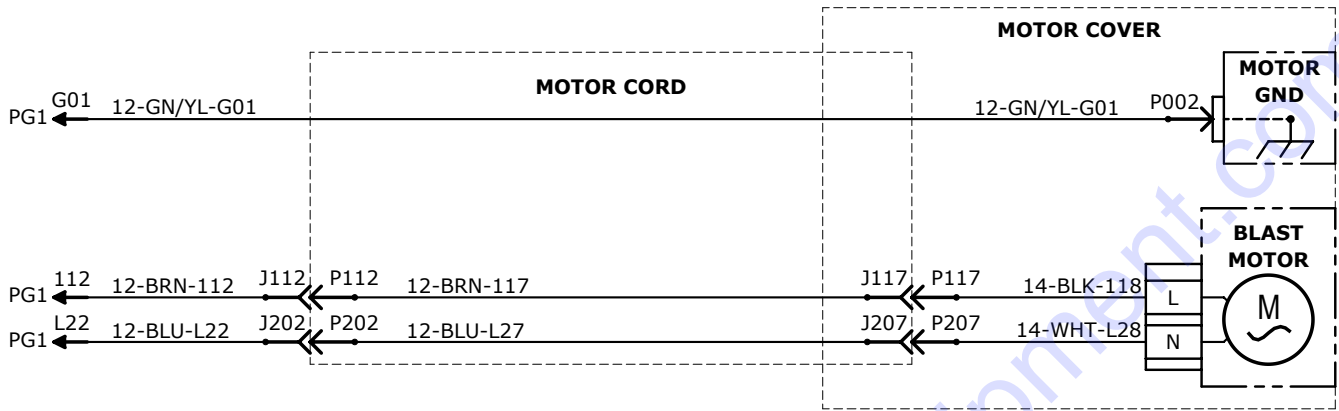

TO PURCHASE THIS PRODUCT PLEASE CONTACT US



**Equipment Financing and
Extended Warranties Available**



**Discount-Equipment.com is your online resource for
commercial and industrial quality parts and equipment sales.**

561-964-4949

visit us on line @ www.discount-equipment.com

Select an option below to find your Equipment

Search by Manufacturer

Search by Product Type

Request a Quote

We sell worldwide for the brands: Genie, Terex, JLG, MultiQuip, Mikasa, Essick, Whiteman, Mayco, Toro Stone, Diamond Products, Generac Magnum, Airman, Haulotte, Barreto, Power Blanket, Nifty Lift, Atlas Copco, Chicago Pneumatic, Allmand, Miller Curber, Skyjack, Lull, Skytrak, Tsurumi, Husquvarna Target, Stow, Wacker, Sakai, Mi-T-M, Sullair, Basic, Dynapac, MBW, Weber, Bartell, Bennar Newman, Haulotte, Ditch Runner, Menegotti, Morrison, Contec, Buddy, Crown, Edco, Wyco, Bomag, Laymor, EZ Trench, Bil-Jax, F.S. Curtis, Gehl Pavers, Heli, Honda, ICS/PowerGrit, IHI, Partner, Imer, Clipper, MMD, Koshin, Rice, CH&E, General Equipment, Amida, Coleman, NAC, Gradall, Square Shooter, Kent, Stanley, Tamco, Toku, Hatz, Kohler, Robin, Wisconsin, Northrock, Oztec, Toker TK, Rol-Air, APT, Wylie, Ingersoll Rand / Doosan, Innovatech, Con X, Ammann, Mecalac, Makinex, Smith Surface Prep, Small Line, Wanco, Yanmar