

PP 455 E

Reservdelar

Spare parts

Ersatzteile

Pieces de rechange

Piezas de repuesto

Ricambi

Peças sobresselente



PARTS FINDER

**Search Website
by Part Number**



**Search Manual
Library For Parts
Manual & Lookup Part
Numbers – Purchase
or Request Quote**

Search Manuals

Enter your information to help us find the right parts manual for your machine.

* Brand:

* Model:

* Serial:

* Part Number:

SEARCH

**Can't Find Part or
Manual? Request Help
by Manufacturer,
Model & Description**

Parts Order Form

Please fill in the following information to help us find the right part for your machine.

Manufacturer:	<input type="text"/>
Model:	<input type="text"/>
Description:	<input type="text"/>
Part Number:	<input type="text"/>
Quantity:	<input type="text"/>
Notes:	<input type="text"/>

Submit

Discount-Equipment.com is your online resource for quality parts & equipment.

Florida: **561-964-4949** Outside Florida TOLL FREE: **877-690-3101**

Need parts?

Click on this link: <http://www.discount-equipment.com/category/5443-parts/> and choose one of the options to help get the right parts and equipment you are looking for. Please have the machine model and serial number available in order to help us get you the correct parts. If you don't find the part on the website or on one of the online manuals, please fill out the request form and one of our experienced staff members will get back to you with a quote for the right part that your machine needs.

We sell worldwide for the brands: Genie, Terex, JLG, MultiQuip, Mikasa, Essick, Whiteman, Mayco, Toro Stone, Diamond Products, Generac Magnum, Airman, Haulotte, Barreto, Power Blanket, Nifty Lift, Atlas Copco, Chicago Pneumatic, Allmand, Miller Curber, Skyjack, Lull, Skytrak, Tsurumi, Husquvarna Target, Stow, Wacker, Sakai, Mi-T-M, Sullair, Basic, Dynapac, MBW, Weber, Bartell, Bennar Newman, Haulotte, Ditch Runner, Menegotti, Morrison, Contec, Buddy, Crown, Edco, Wyco, Bomag, Laymor, EZ Trench, Bil-Jax, F.S. Curtis, Gehl Pavers, Heli, Honda, ICS/PowerGrit, IHI, Partner, Imer, Clipper, MMD, Koshin, Rice, CH&E, General Equipment, Amida, Coleman, NAC, Gradall, Square Shooter, Kent, Stanley, Tamco, Toku, Hatz, Kohler, Robin, Wisconsin, Northrock, Oztec, Toker TK, Rol-Air, APT, Wylie, Ingersoll Rand / Doosan, Innovatech, Con X, Ammann, Mecalac, Makinex, Smith Surface Prep, Small Line, Wanco, Yanmar

No.	Pos.	Description	No.	Pos.	Description
501 36 87-01	A	Motor 400V Water cooled	531 11 72-18	E	Socket
501 36 87-02	A	Motor 230V Water cooled	531 11 72-20	DE	Automatic fuse 4A
501 36 87-03	A	Motor 575V Water cooled	531 11 72-40	G	Gasket
501 36 87-04	A	Motor 200V Water cooled	531 11 72-50	E	Transformer 400V-600V/230V
501 36 89-01	C	Head	531 11 72-51	G	Emergency stop cpl
501 36 92-01	D	Cover	531 11 72-52	G	Circuite breaker
501 36 93-01	BI	Cover	531 11 72-53	G	Batterypack
501 36 94-01	F	Main block	531 11 72-54	G	Charger
504 00 37-01	H	Type plate	531 11 72-64	E	Double phase deq. Sensor 600V
504 00 40-01	G	Type plate	531 11 72-65	D	Electric inlet point 63A 600V
504 02 99-05	H	Label	531 11 72-66	D	Extension socket 600V
504 05 50-01	G	Display label	531 11 72-68	C	Cannon connector (with cable)
504 69 48-01	E	Motor protection 9-45A	531 11 72-75	D	Electric inlet point 63A 200V
504 69 48-02	E	Motor protection 5,4-27A	531 11 72-84	E	Double phase deq. Sensor 200V
504 69 51-01	E	Socket 9-45A	531 11 72-85	D	Extension socket 200V
504 69 51-02	E	Socket 5,4-27A	531 11 73-06	E	Contactora 200V
504 73 80-01	I	Spacing block	531 11 73-64	A	Cap PG21
504 73 81-01	I	Spacing block	531 11 80-23	B	Cutting ring D10L
505 23 80-01	C	Cover	531 11 80-25	B	Cutting ring D15L
505 46 11-01	D	Emergency stop button	531 11 80-41	CJ	Hydraulic coupling
505 46 12-01	D	Adapter	531 11 80-42	CJ	Hydraulic coupling
505 46 13-01	D	Contact block	531 11 80-45	CJ	Hydraulic coupling
505 52 03-01	D	Emergency stop button cpl.	531 11 80-46	CJ	Hydraulic coupling
505 52 67-01	D	Protective shutter	531 11 80-51	D	Level gauge
506 60 67-01	D	Screw	531 11 80-56	B	Hydraulic coupling
510 36 18-01	C	Plug	531 11 80-68	B	Cutting nut M15L
522 67 51-01	A	Washer	531 11 81-13	D	Magnetic plug
531 11 50-12	G	Can bus cable 6m	531 11 81-19	F	Water coupling
531 11 50-20	C	Water valve	531 11 81-20	F	Water coupling
531 11 51-22	DE	Electric plate compl.	531 11 81-21	A	Coupling
531 11 51-40	DE	Electric plate compl.	531 11 81-22	F	Pressure reducing valve
531 11 51-57	B	Pressure pipe compl.	531 11 81-23	F	Load retaining valve
531 11 51-63	DE	Electric plate compl.	531 11 81-24	F	Directional valve
531 11 51-68	A	Shaft coupling compl.	531 11 81-25	F	Flow valve
531 11 51-71	DE	Electric plate compl.	531 11 81-26	F	Flow valve
531 11 51-83	G	Potentiometer knob compl.	531 11 81-27	F	Pilot controlled differential valve
531 11 51-88	I	Saw carriage with cover	531 11 81-28	F	Pilot controlled differential valve
531 11 51-90	J	Hose set complete	531 11 81-32	B	Hydraulic coupling
531 11 52-34	F	Pressure transducer	531 11 81-33	B	Hydraulic coupling
531 11 52-35	B	Pipe	531 11 81-34	B	Hydraulic coupling
531 11 52-36	B	Pipe	531 11 81-38	B	Banjo
531 11 52-37	I	Saw carriage without cover	531 11 81-42	B	Filter insert
531 11 52-38	G	Battery charger 200V	531 11 81-65	J	Feeding hose 1/4"
531 11 70-34	G	Cannon connector	531 11 81-76	D	Nut M26x1,5
531 11 70-36	D	DIN rail	531 11 81-88	B	Cutting nut M10L
531 11 70-38	E	Double phase deq. sensor 400V	531 11 81-90	F	Hose
531 11 70-54	E	Auxiliary contact	531 11 82-00	C	Nipple
531 11 70-55	E	Auxiliary contact	531 11 82-18	J	Quick coupling male 13411
531 11 70-56	E	Main connectors 43A KIT	531 11 82-19	CJ	Quick coupling
531 11 70-57	E	Main connectors 43A KIT	531 11 82-47	J	Rubber band
531 11 70-59	D	Electric inlet point 63A 380V	531 11 82-57	F	Pressure reducing valve SV08
531 11 70-67	G	Connection block NO	531 11 82-81	B	Hydraulic pump (for 50Hz)
531 11 70-68	E	Contactora	531 11 82-83	B	Pump (for 60Hz)
531 11 70-96	G	Potentiometer remote control	531 11 82-90	F	Water coupling steel
531 11 70-97	C	Potentiometer knob	531 11 83-23	J	Hose set without couplings
531 11 71-00	E	Terminal block	531 11 83-36	J	Hydraulic hose 3/4"
531 11 71-01	E	Terminal block	531 11 83-37	C	Adapter
531 11 71-02	E	Relay 12V	531 11 83-41	B	Cooler
531 11 71-32	D	Extension socket	531 11 83-42	B	Check valve
531 11 71-40	D	Transformer	531 11 83-43	B	Hydraulic coupling
531 11 71-44	G	Push-button	531 11 83-44	B	Hydraulic coupling
531 11 71-45	E	Varistor	531 11 83-45	B	Hose
531 11 71-54	D	Socket 230V double	531 11 83-46	F	Water coupling, banjo
531 11 71-59	G	Gasket	531 11 83-47	F	Electromagnetic water valve
531 11 71-68	E	Mechanical interlock	531 11 83-55	A	Water coupling
531 11 71-73	E	End plate	531 11 83-56	C	Adapter
531 11 71-74	E	End support	531 11 90-07	A	Wheel
531 11 71-84	E	Contactora 200V	531 11 90-08	B	Ventilation hose
531 11 71-94	D	Extension socket 63A 230V	531 11 90-30	B	Air filter
531 11 72-08	D	Personal safety guard	531 11 90-31	A	Washer 13x36

No.	Pos.	Description	No.	Pos.	Description
531 11 91-26	G	Strap	531 14 20-82	A	Gauge bracket
531 11 91-31	B	Hose clamp	531 14 20-86	H	Decal
531 11 91-33	C	O-ring string 181x1,78	531 14 20-92	G	Chargercable
531 11 91-34	B	O-ring string 1130x6	531 14 21-06	D	Transformer module
531 11 91-81	B	Washer 10,5x22	531 14 21-10	B	Filter hose
531 11 91-83	A	Washer 13x24x2	531 14 21-12	A	PP455 Chassie
531 11 91-85	CDJ	Sealing ring 1/2"	531 14 21-18	A	Mount
531 11 92-02	A	Screw M6S 12x25	531 14 21-19	A	Handle
531 11 92-07	A	Screw M6S 12x45	531 14 21-20	A	Mount2
531 11 92-19	A	Screw M6S 8x30	531 14 21-26	A	Water hose
531 11 92-20	A	Screw M6S 8x35	531 14 21-43	D	Adapter
531 11 92-24	A	Screw M6SF 8x20	531 14 21-44	F	Water pipe
531 11 92-32	B	Screw MC6S 6x14	531 14 21-45	B	Mounting plate cooler
531 11 92-33	C	Screw MC6S 6x160	531 14 21-46	F	Water pipe
531 11 92-74	C	O-ring 29,2x3	531 14 21-49	B	Hose
531 11 92-93	B	O-ring 80x1,6	574 02 85-01	EG	Radio card
531 11 92-95	B	O-ring 98,02x3,53	575 71 67-01	B	Housing
531 11 92-99	A	Wedge PK 10x8x30	575 71 68-01	B	Ventilation valve
531 11 93-41	BCF	Plug VSTI R1/4"	576 21 49-01	I	Bushing compl.
531 11 93-49	B	Sealing ring 44,45	578 23 20-01	F	Lid
531 11 93-53	B	Screw MLC6S 6x12	578 32 77-01	F	Main board v 2.14
531 11 93-54	B	O-ring 63x2	578 32 77-02	F	Main board v 2.15
531 11 93-85	FG	Spacer mainboard	578 32 77-03	F	Main board v 2.16
531 11 94-26	I	Screw K6S 6x16 10.9 fzb	578 32 77-04	F	Main board v 2.17
531 11 94-53	I	Levell	578 32 78-01	G	Control board v 2.14
531 11 94-54	I	Spring	578 32 78-02	G	Control board v 2.15
531 11 94-56	A	Curled screw	578 32 78-03	G	Control board v 2.16
531 11 95-13	A	Lifting eye bolt M12	578 32 78-04	G	Control board v 2.17
531 11 95-25	BD	Sealing ring 3/4	578 32 79-01	G	Remote control v 2.14
531 11 96-06	A	Lock nut kit	578 32 79-02	G	Remote control v 2.15
531 12 22-52	J	Water hose	578 32 79-03	G	Remote control v 2.16
531 12 30-02	I	Socket	578 32 79-04	G	Remote control v 2.17
531 12 30-03	I	Holder shaft right	578 32 80-01	F	Main board v 2.18
531 12 30-04	I	Holder shaft left	578 32 81-01	G	Control board v 2.18
531 12 30-09	I	Handle	578 32 82-01	G	Remote control v 2.18
531 12 30-10	I	Bar	720 12 71-50	I	Cylindrical pin 4x18
531 12 30-11	I	Excentric locking shaft	720 13 08-50	I	Cylindrical pin 5x16
531 12 30-12	I	Locking clamp	723 12 24-01	CG	Screw MCS 3x10
531 12 30-13	I	Sprint	723 12 87-01	C	Screw MCS 4x8
531 12 30-18	I	Nut	723 12 91-01	D	Screw MCS 4x12
531 12 31-00	J	Aluminium washer red	723 13 28-01	E	Screw MCS 5x14
531 14 11-67	B	Ventilation hose nipple	723 52 22-01	G	Screw MFS 3x8
531 14 11-68	B	Ventilation nipple	723 52 89-01	DF	Screw MFS 4x10
531 14 11-91	H	Electric data label	723 52 92-01	D	Screw MFS 4x14
531 14 12-05	H	Sign flash	723 53 25-01	D	Screw MFS 5x10
531 14 12-11	H	Sign drain cooler	725 24 63-71	A	Screw M6S 8x60H
531 14 12-34	H	Varning sign	725 25 42-51	I	Screw M6S 12x50
531 14 20-04	A	Bearing cover	725 52 20-01	DF	Screw MC6S 3x6
531 14 20-09	B	Filter bracket	725 53 31-01	D	Screw MC6S 5x20
531 14 20-10	B	Screw attachment	725 53 33-55	B	Screw MC6S 5x25
531 14 20-11	G	Control plate	725 53 64-01	A	Screw MC6S 6x10
531 14 20-13	G	Potentiometer nut	725 53 68-01	ACDI	Screw MC6S 6x16
531 14 20-18	B	Pressure block	725 53 70-01	B	Screw MC6S 6x20
531 14 20-19	B	Suction block	725 53 72-01	AD	Screw MC6S 6x25
531 14 20-20	B	Pressure block	725 53 74-01	D	Screw MC6S 6x30
531 14 20-21	B	Cooler connection	725 53 78-01	B	Screw MC6S 6x40
531 14 20-23	D	Cable tubing	725 54 93-01	B	Screw MC6S 10x25
531 14 20-27	F	Electronic box cover	725 63 66-51	CD	Screw MF6S 6x12
531 14 20-28	D	Fuse holder	728 73 60-05	A	Stop screw S6SS 6x6
531 14 20-29	E	Electric plate compl	728 73 64-05	I	Stop screw 6x10
531 14 20-32	B	Filter housing	731 23 10-01	G	Nut M3
531 14 20-43	B	Suction pipe	731 23 16-01	CD	Nut M6
531 14 20-45	B	Pressure pipe	731 23 18-01	A	Nut M8
531 14 20-52	B	Oil cap	732 25 12-01	D	Locking nut M4
531 14 20-53	B	Oil armatures	732 25 14-01	D	Locking nut M5
531 14 20-54	A	Support washer	734 11 46-01	CDE	Washer 5,3x10x1
531 14 20-55	D	Transformer bracket	734 11 52-01	ACD	Washer 6,4x12
531 14 20-62	G	Remote box	734 11 63-01	A	Washer 8,4x16
531 14 20-71	H	Sound label	740 38 08-01	BC	Sealing ring M6
531 14 20-79	F	Hose pressure transducer	740 38 18-01	CDJ	Sealing ring 1/8

No.	Pos.	Description	No.	Pos.	Description
740 38 27-01	AFIJ	Sealing ring 1/4			
740 38 34-01	B	Sealing ring 3/8			
740 42 17-00	G	O-ring 19,1x1,6			
740 43 13-00	B	O-ring 15,3x2,4			
740 44 04-00	BC	O-ring 19,2x3			
740 44 05-00	B	O-ring 22,2x3			
740 44 12-00	C	O-ring 39,2x3			

Go to Discount-Equipment.com to order your parts

A

PP 455 E

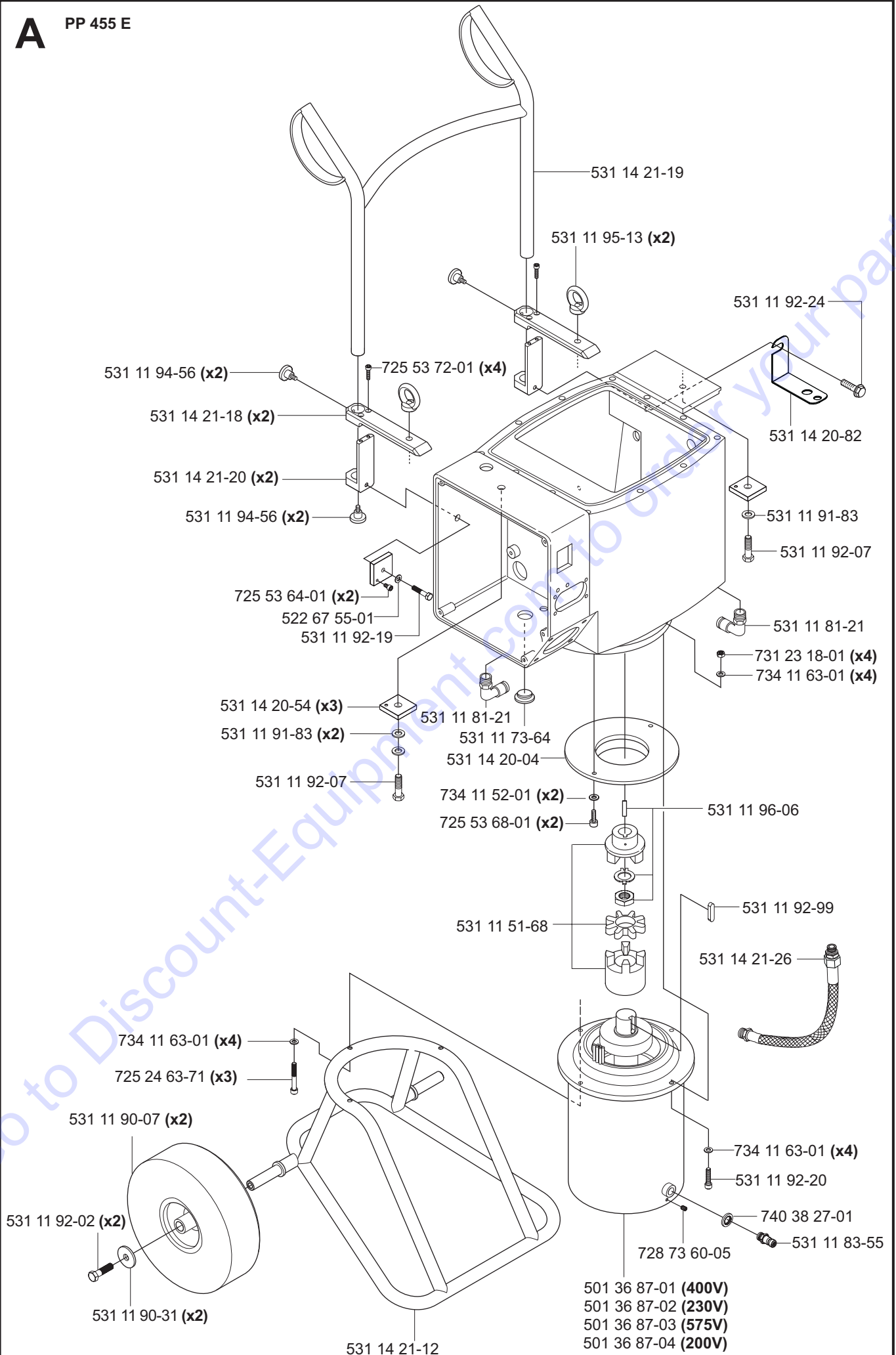

C

PP 455 E

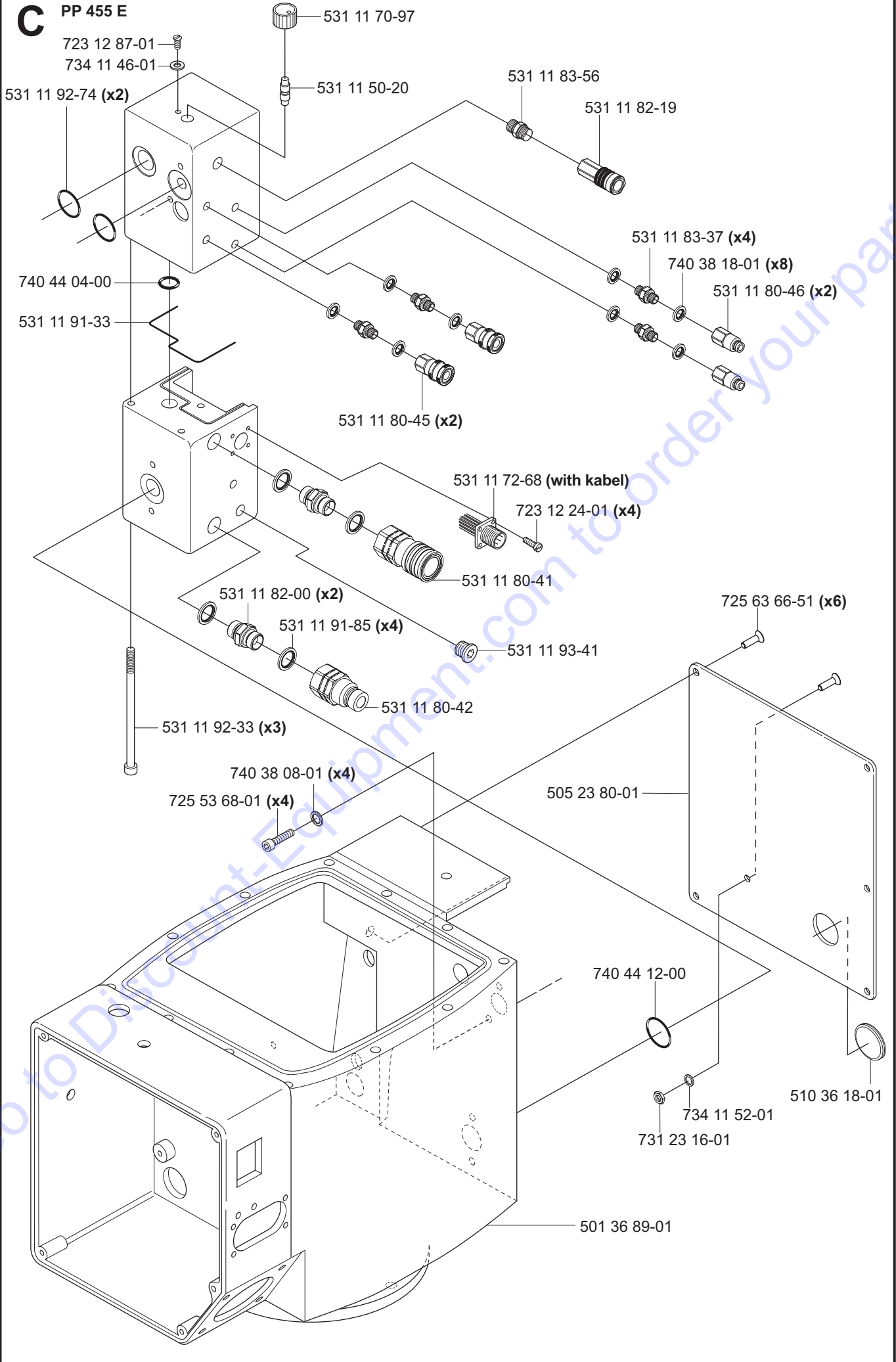

D PP 455 E

**compl 505 52 03-01

compl 531 11 51-40 (EUR 400V/US 440V)
compl 531 11 51-63 (CAN 600V)
compl 531 11 51-22 (NOR 230V/400V)
compl 531 11 51-71 (JAP 200V)

**505 46 11-01

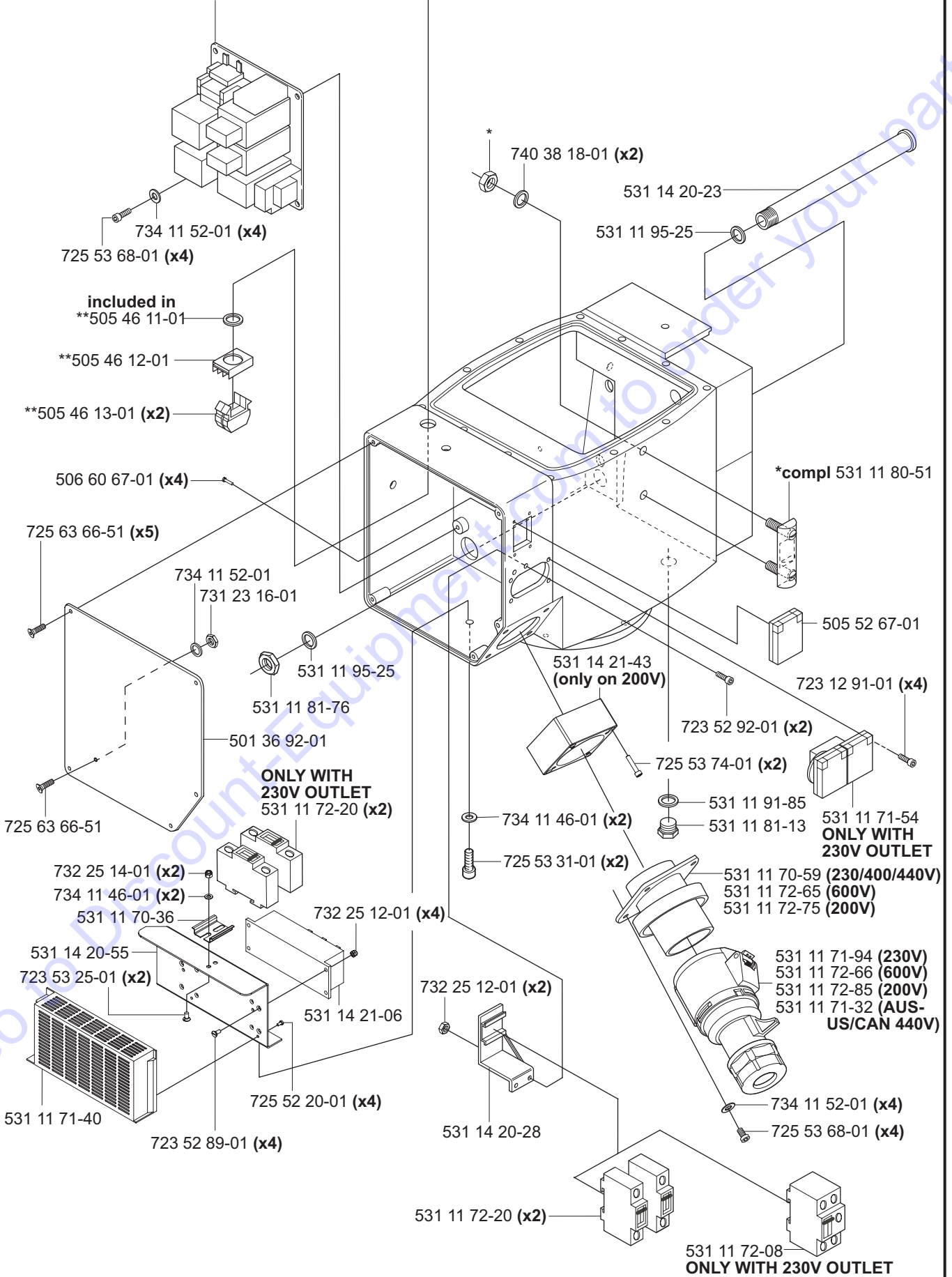

E

PP 455 E

Electric plate

compl 531 11 51-40 (EUR 400V/US 440V)

compl 531 11 51-71 (JAP 200V)

compl 531 11 51-63 (CAN 600V)

compl 531 11 51-22 (NOR 230/400V)

531 14 20-29

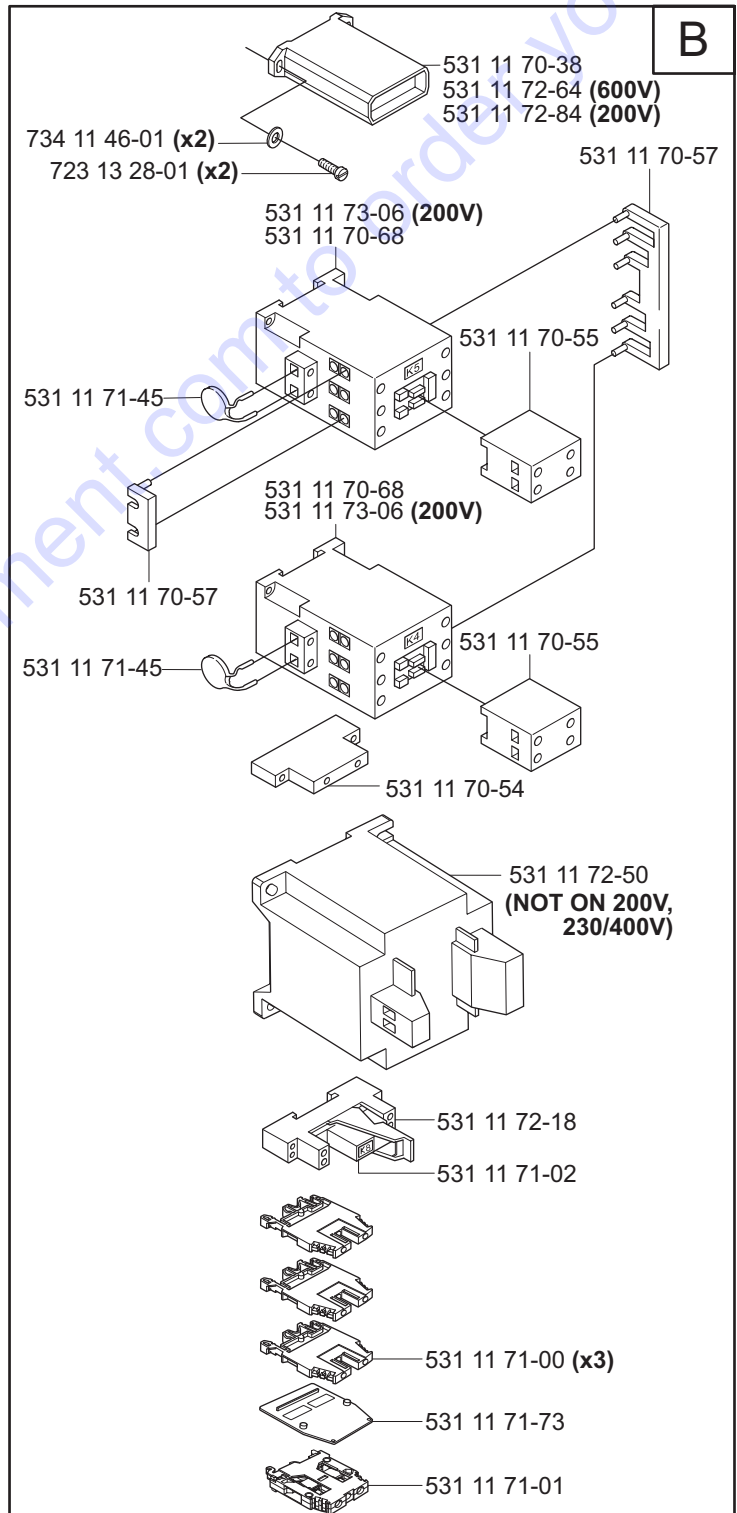
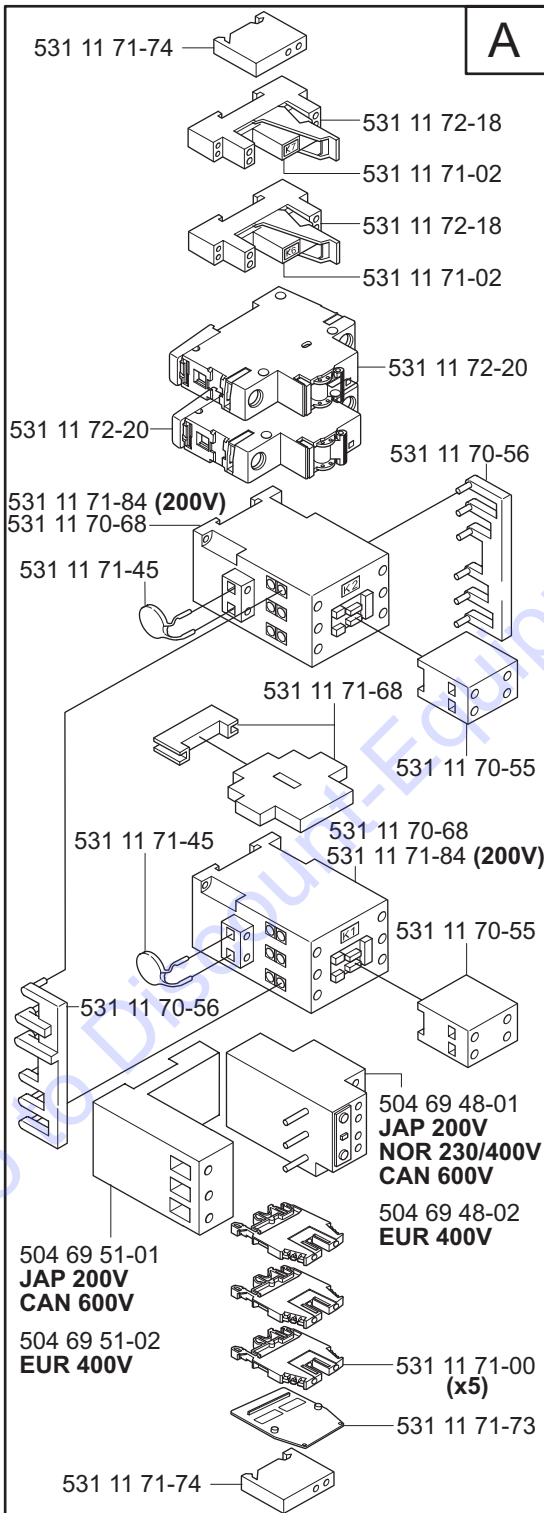
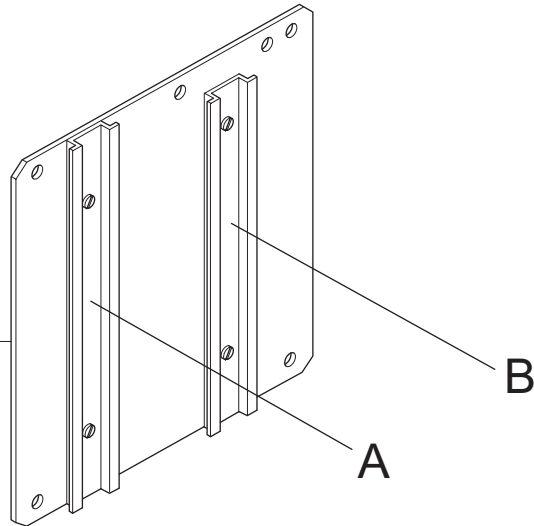
See electric wiring diagram
for cable dimensions etc.

F PP 455 E

Variant	Main board No.	Machine no.	Version
400-440V	578 32 77-01	- 4392	2.14
200V	578 32 77-02	- 4392	2.15
600V	578 32 77-03	- 4392	2.16
230/400V	578 32 77-04	- 4392	2.17
ALL	578 32 81-01	4393 -	2.18

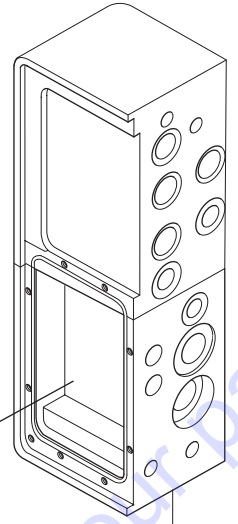

578 23 20-01
723 52 89-01 (x8)

574 02 85-01

531 11 93-85 (x8)

725 52 20-01 (x2)

501 36 94-01

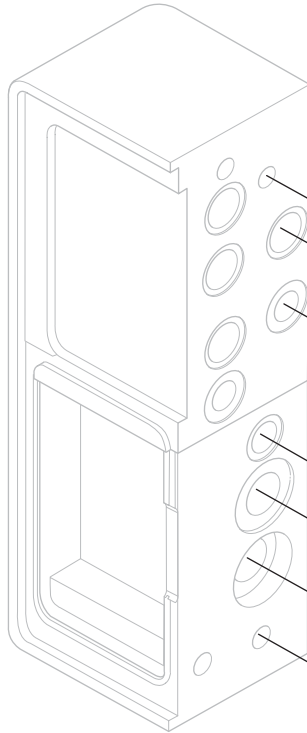

531 11 81-27

531 11 81-19

531 11 81-24

531 11 82-57

531 11 81-28

531 11 83-46

531 11 81-26

740 38 27-01

531 11 83-46

531 11 93-41

531 14 20-79

531 11 81-22

531 11 52-34

531 11 81-25

531 11 83-47

531 11 81-23

531 11 81-20

531 11 81-24

531 11 81-19

531 11 81-19

531 11 81-90
(l=42 mm)

531 11 81-19

531 14 21-46

531 11 82-90

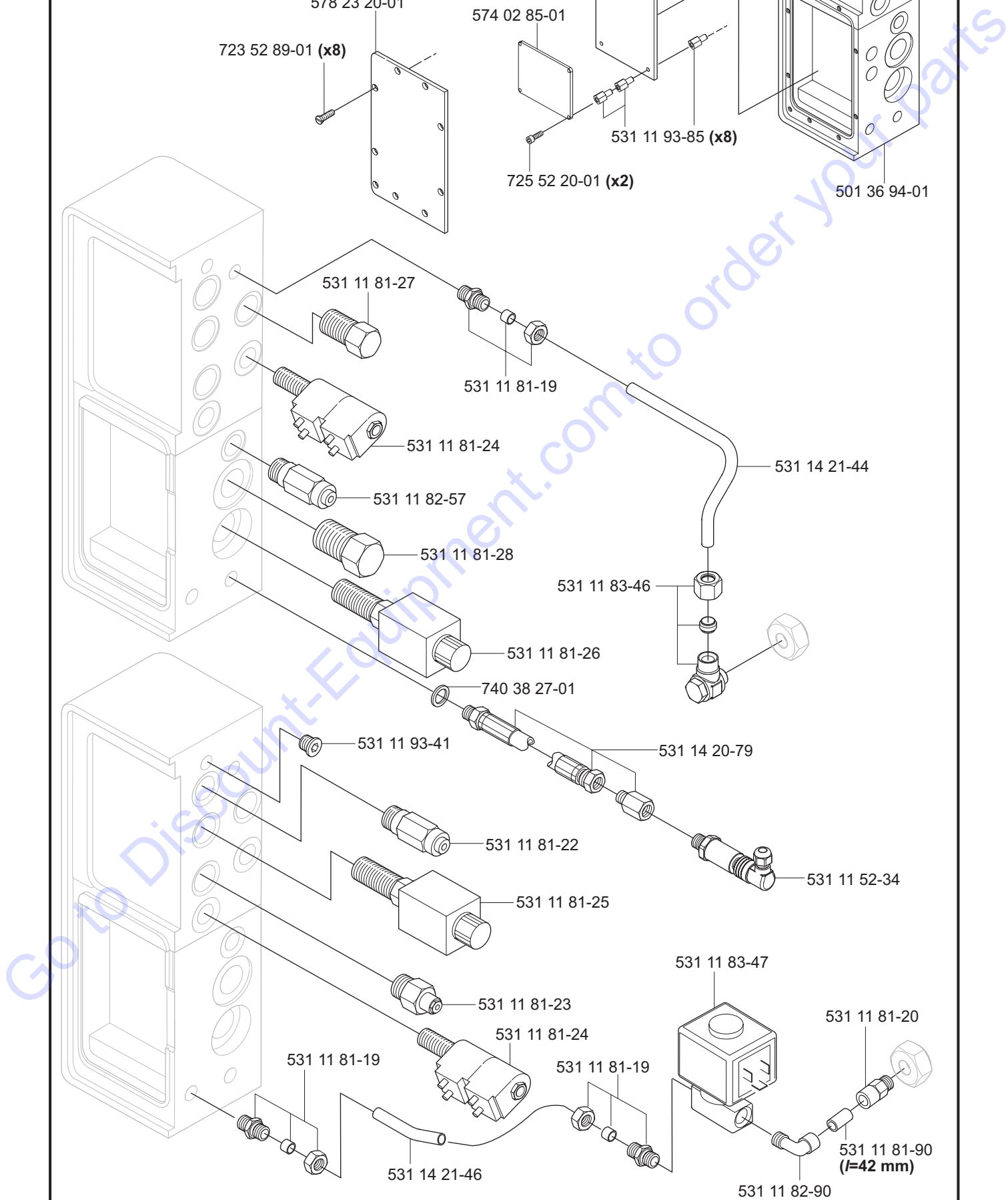

G

PP 455 E

Radio remote control compl.

Variant	Remote control No.	Machine no.	Version
400-440V	578 32 79-01	- 4392	2.14
200V	578 32 79-02	- 4392	2.15
600V	578 32 79-03	- 4392	2.16
230/400V	578 32 79-04	- 4392	2.17
ALL	578 32 82-01	4393 -	2.18

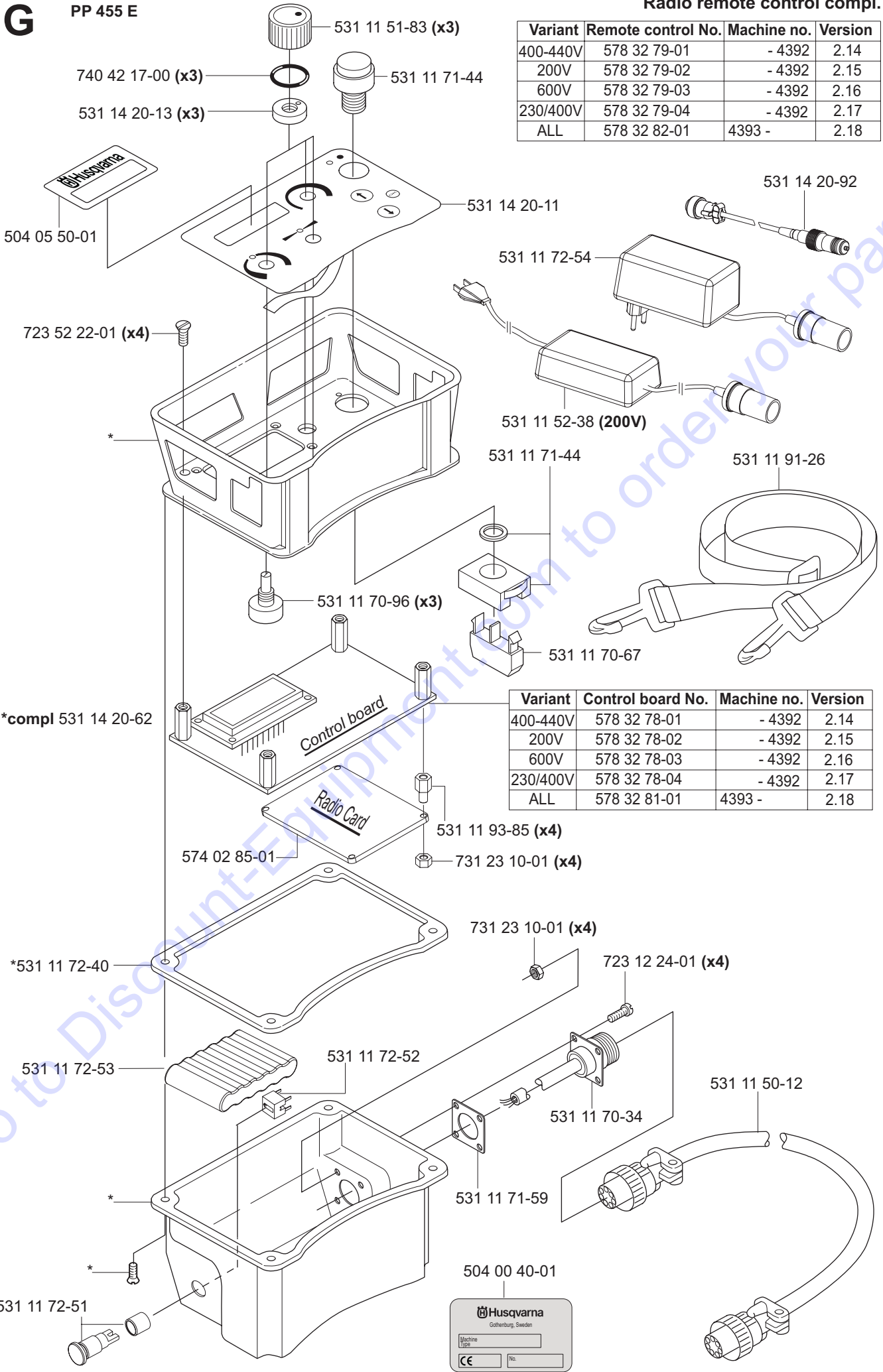

Variant	Control board No.	Machine no.	Version
400-440V	578 32 78-01	- 4392	2.14
200V	578 32 78-02	- 4392	2.15
600V	578 32 78-03	- 4392	2.16
230/400V	578 32 78-04	- 4392	2.17
ALL	578 32 81-01	4393 -	2.18

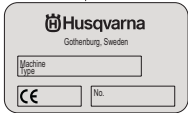

H PP 455 E

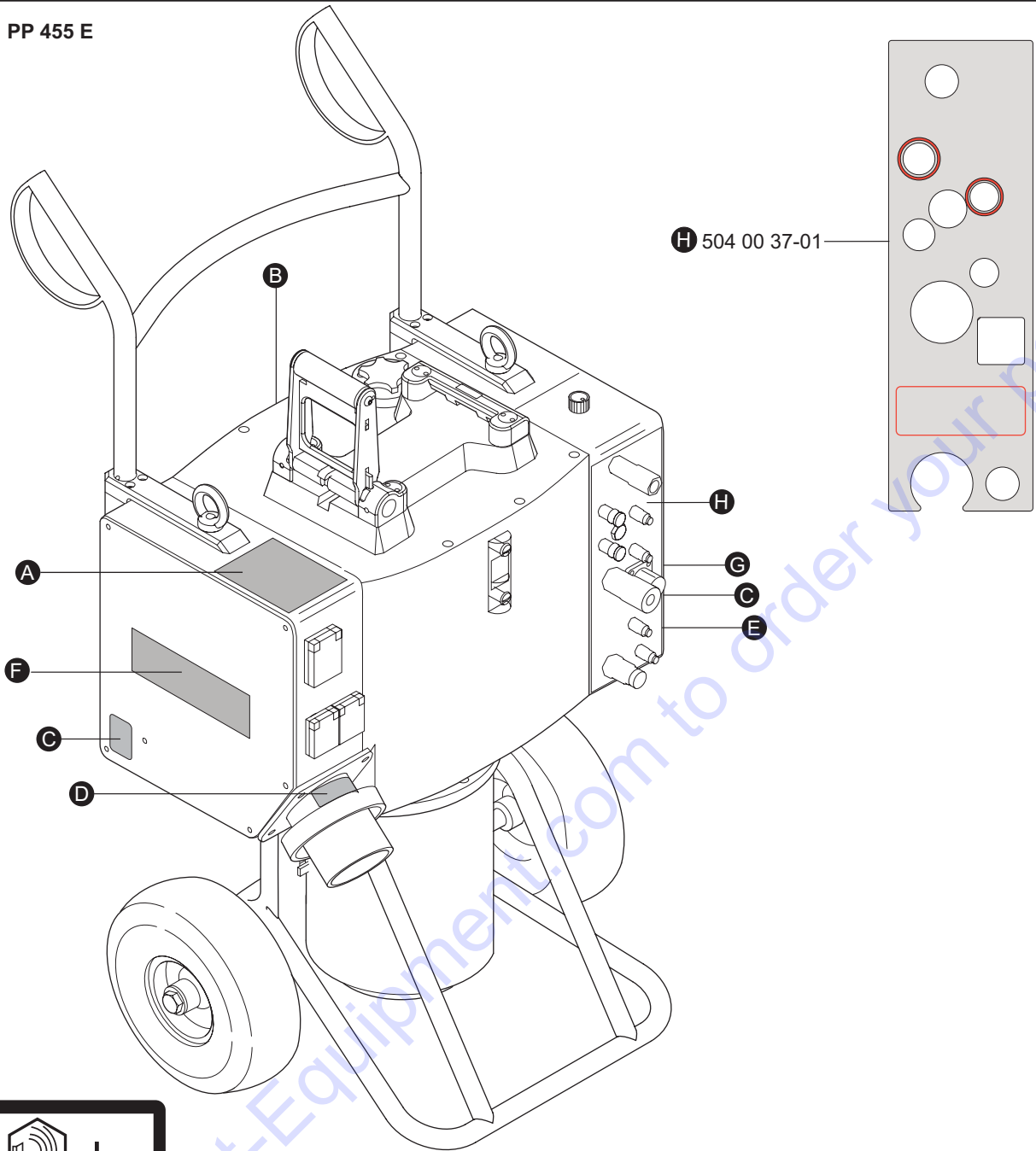

531 14 20-71 **A**



531 14 12-05 (x2) **C**



531 14 12-34 **B**

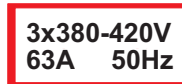

531 14 11-91 **D**

531 14 12-11 **E**

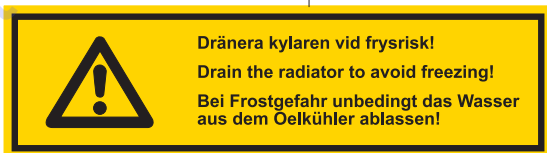

531 14 20-86 **G**



504 02 99-05 **F**

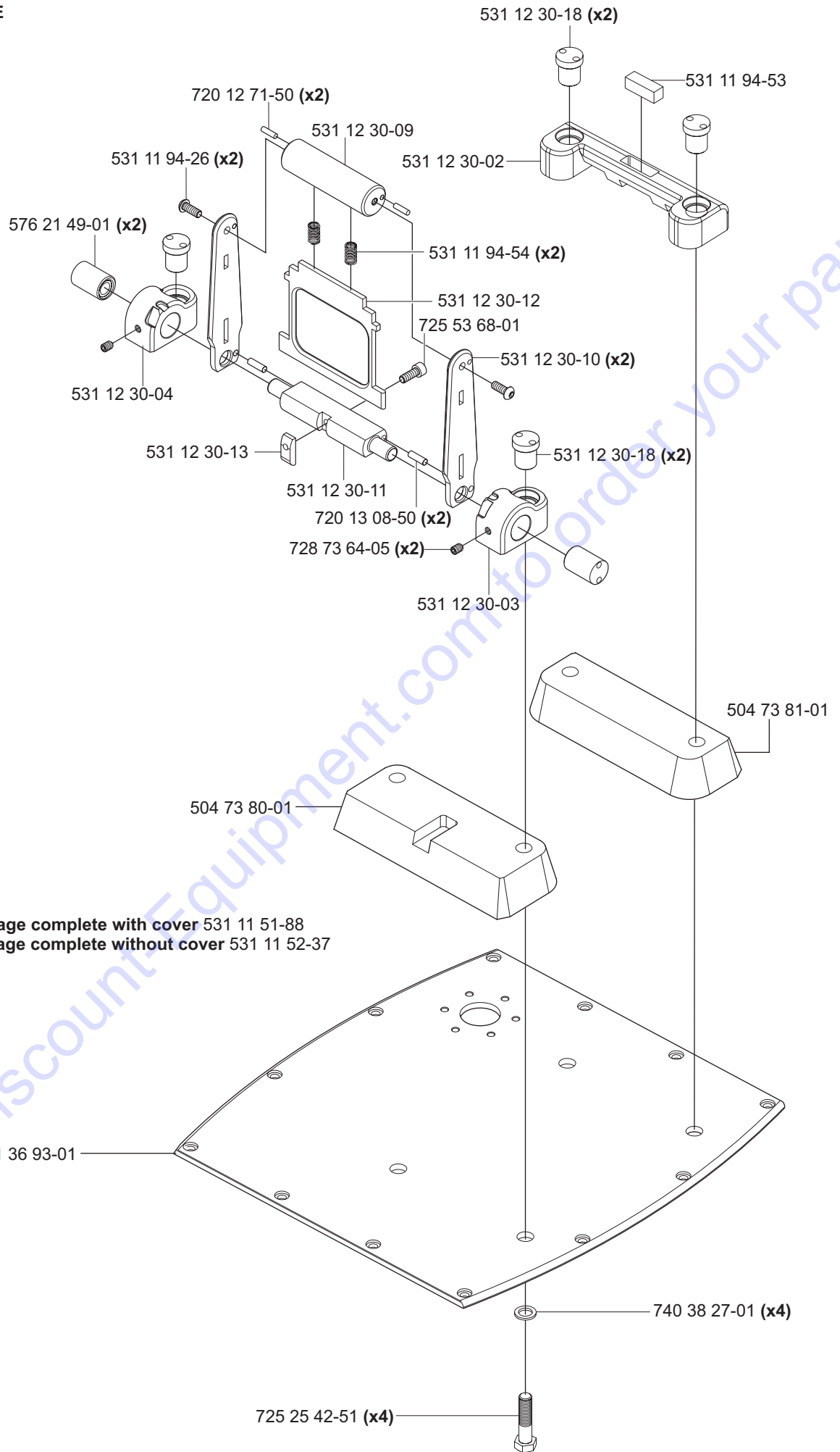

J PP 455 E

Hose set complete 531 11 51-90

Hose set without couplings 531 11 83-23

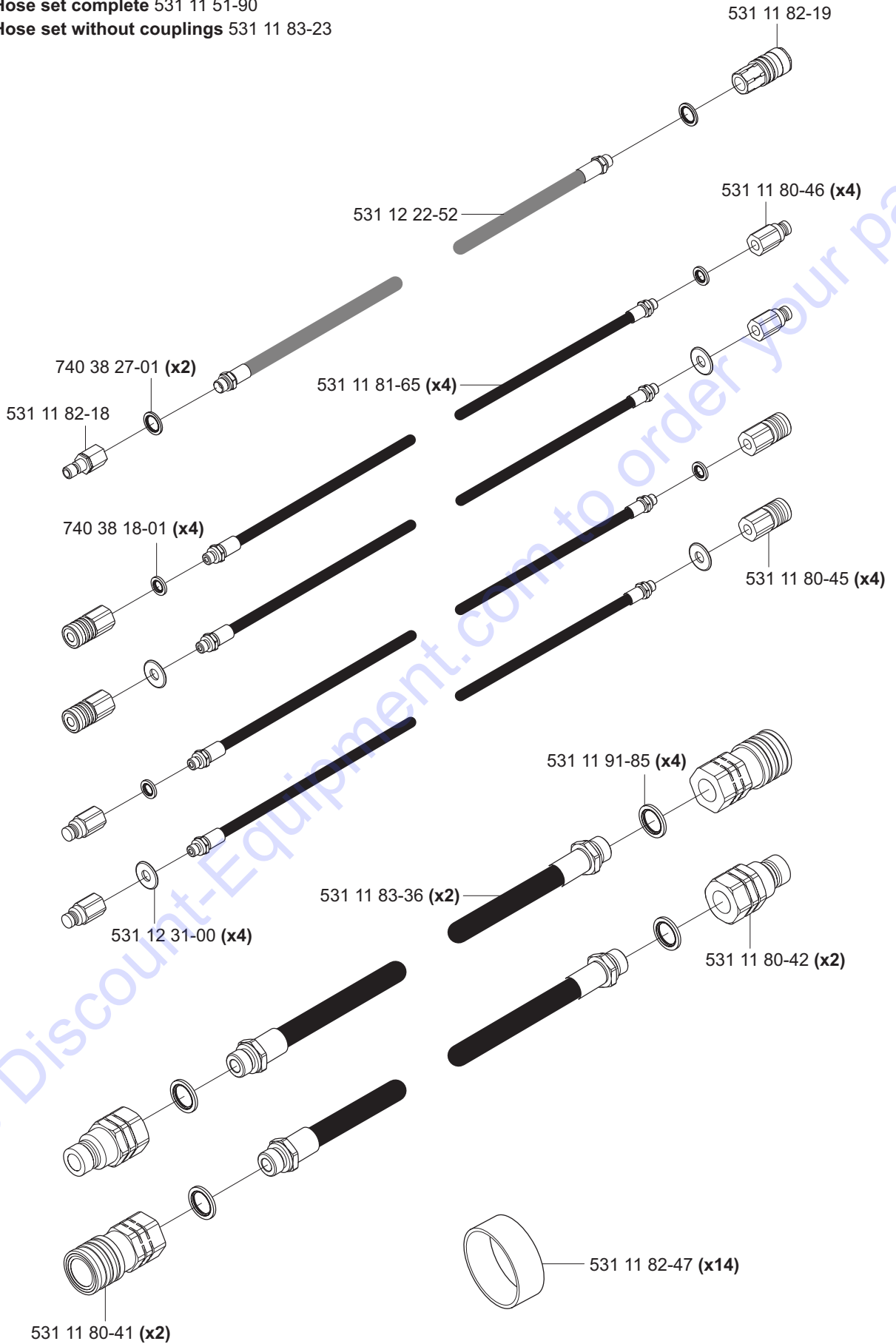

PARTS FINDER

**Search Website
by Part Number**



**Search Manual
Library For Parts
Manual & Lookup Part
Numbers – Purchase
or Request Quote**

Search Manuals

Enter your information to help us find the right parts manual for your machine.

* Brand:

* Model:

* Serial:

* Part Number:

SEARCH

**Can't Find Part or
Manual? Request Help
by Manufacturer,
Model & Description**

Parts Order Form

Please fill in the following information to help us find the right part for your machine.

Manufacturer:	<input type="text"/>
Model:	<input type="text"/>
Description:	<input type="text"/>
Part Number:	<input type="text"/>
Quantity:	<input type="text"/>
Notes:	<input type="text"/>

Discount-Equipment.com is your online resource for quality parts & equipment.

Florida: **561-964-4949** Outside Florida TOLL FREE: **877-690-3101**

Need parts?

Click on this link: <http://www.discount-equipment.com/category/5443-parts/> and choose one of the options to help get the right parts and equipment you are looking for. Please have the machine model and serial number available in order to help us get you the correct parts. If you don't find the part on the website or on one of the online manuals, please fill out the request form and one of our experienced staff members will get back to you with a quote for the right part that your machine needs.

We sell worldwide for the brands: Genie, Terex, JLG, MultiQuip, Mikasa, Essick, Whiteman, Mayco, Toro Stone, Diamond Products, Generac Magnum, Airman, Haulotte, Barreto, Power Blanket, Nifty Lift, Atlas Copco, Chicago Pneumatic, Allmand, Miller Curber, Skyjack, Lull, Skytrak, Tsurumi, Husquvarna Target, Stow, Wacker, Sakai, Mi-T-M, Sullair, Basic, Dynapac, MBW, Weber, Bartell, Bennar Newman, Haulotte, Ditch Runner, Menegotti, Morrison, Contec, Buddy, Crown, Edco, Wyco, Bomag, Laymor, EZ Trench, Bil-Jax, F.S. Curtis, Gehl Pavers, Heli, Honda, ICS/PowerGrit, IHI, Partner, Imer, Clipper, MMD, Koshin, Rice, CH&E, General Equipment, Amida, Coleman, NAC, Gradall, Square Shooter, Kent, Stanley, Tamco, Toku, Hatz, Kohler, Robin, Wisconsin, Northrock, Oztec, Toker TK, Rol-Air, APT, Wylie, Ingersoll Rand / Doosan, Innovatech, Con X, Ammann, Mecalac, Makinex, Smith Surface Prep, Small Line, Wanco, Yanmar