

Wanco® Light Towers



WANCO® The industry leader.

800-972-0755
www.wanco.com



**Working late?
Light up your job site with Wanco® Light Towers.**

Not just another light tower, Wanco Light Towers use state-of-the-art technology to achieve the most efficient illumination, shining a uniform light pattern across the entire job site.

Other advancements include a choice of low-speed engines that provide trouble-free diesel performance and greater longevity, and unsurpassed engine accessibility via a maintenance panel that lifts completely out of the way.

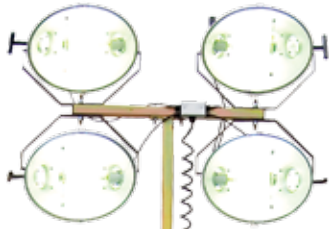

Now get Wanco ingenuity in a portable light tower.

Wanco has been building light towers for 25 years. With this kind of experience, it's no wonder the Wanco Light Tower has turned heads. Our engineering expertise and dedication to quality have made the Wanco Light Tower unique, with innovation the industry has never seen.

Portable light towers are ideal for wide-area outdoor lighting in a variety of construction, commercial and special event applications. Wanco Light Towers feature four 1000-watt light fixtures atop a 30-foot variable-height mast.

- **High-output light fixtures** provide super-bright illumination and uniform light coverage
- **Rotating tower assembly** turns 360 degrees, and the lights operate at any height
- **Multiple low-speed engine options** offer trouble-free diesel performance and greater longevity
- **Unobstructed engine accessibility** with hinged top panel, provides full access to engine, generator and electrical components



With a reputation for service and integrity, Wanco products feature superb functionality, unique features, versatility and dependability.

Light fixtures

The Wanco Light Tower's high-output fixtures feature a high-intensity parabolic reflector that increases illumination and creates a brighter, more uniform light pattern. The result is greater visibility and improved safety for workers. For fast job-site setup and less downtime, each light fixture can be aimed independently without the use of tools—and the fixtures stay in place once positioned.

Tower

The telescoping tower assembly is compact when stored, yet extends to 30 feet when deployed. Two winches raise and extend the mast easily. Power- and hand-operated winches are available. In the upright position, the light tower mast rotates 360 degrees, and the lights can be operated at any height, preventing the trailer from having to be moved frequently.

Power system

The power system includes a choice of rugged, low-RPM, Tier 4i diesel engines and high-quality four-pole generators. A 30-gallon fuel tank provides extended run times of 60 to 70 hours between refueling. The rugged, translucent polyethylene fuel tank is rupture resistant and offers an instant view of fuel level, eliminating the need for a fuel gauge.

Serviceability

Wanco has created a unique innovation that greatly improves serviceability. For complete access to the engine, generator and electrical components, the Wanco Light Tower features a hinged top panel that rises with the mast when maintenance is required. No other light tower makes engine access this easy. The gull-wing side doors may be opened while the maintenance panel is raised, further enhancing access.



Hinged top panel opens fully. The light tower mast attaches to the panel for maintenance and raises the panel using the drawbar winch.



Engine and components are easily accessible with top panel up. Crossbar can be removed and side doors can be opened with panel raised.

Specifications

Physical

Dimensions in inches (cm)

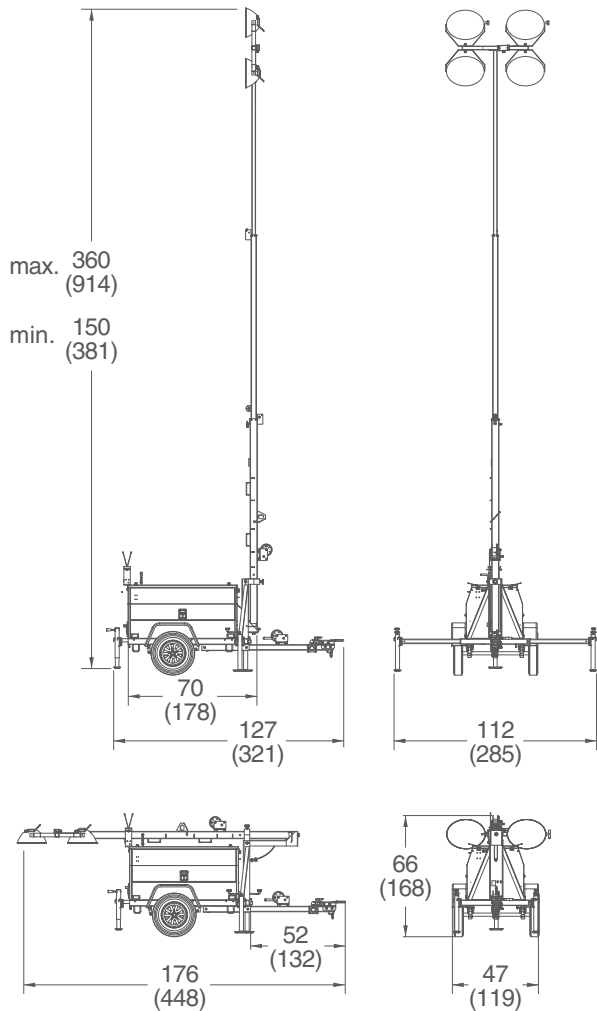

Operating weight	1800 lbs. (815kg)
Shipping weight	1580 lbs. (717kg)
Tires	ST175/80D13
Tow hitch	Combo-type for 2-inch ball and 3-inch pintle hook

Lights

Lamps	Four metal halide lamps
Wattage	1000 watts per lamp
Luminosity	Up to 0.5 fc at 7.5 acres (5.4 lm/m ² at 30,400 m ²)

Output power

Output	6 kW
Voltage	120 V or 240 V*
Amperage	50 A @ 120 V 25 A @ 240 V
Frequency	60 Hz or 50 Hz*
Voltage regulation	±5%, no load to full load

Power system

Engine type	Tier 4 diesel, 3-cylinder, 4-cycle
Engine speed	1800 rpm
Generator type	Brushless
Generator insulation	H
Battery	12 V dc, 550 CCA
Maximum power output	12.1 or 13.6 hp (9 or 10 kW)*
Displacement	56 or 68 cu. in. (916 or 1123cm ³)*
Sound level at maximum load	71 dB at 23 feet (7m)
Fuel tank capacity	30 gal. (114L)
Fuel consumption	0.44 gal./hr. (1.67L/h)
Runtime before refueling	60 to 70 hrs., approx.

Functional

Steel enclosure protects components from the elements. Enclosure is powder-coated, lockable, and weather-resistant.

Two outriggers and four leveling jacks provide stability.

Control panel features elapsed hour meter, 120-volt GFCI receptacle for powering external equipment, and circuit breakers for on/off functionality and protection.

Diesel engine includes glow-plug preheat system for increased service life and improved cold-weather starting.

Automatic engine shutdown system protects engine from damage due to low oil pressure and high coolant temperature.

For maintenance, hinged top panel provides unimpeded access to engine, generator, and electrical components.

Options include a choice of engines, 7.5 or 8 kW generator, 240V Twist-Lock® receptacle, block heater, fuel/water separator and electric winches.

*Depending on model

*Due to Wanco's commitment to continuous improvement of our products, all information is subject to change without notice.
Wanco and the Wanco logo are registered trademarks of Wanco Inc. All other trademarks are property of their respective owners.*



WANCO INC.
5870 Tennyson Street
Arvada, Colorado 80003
800-972-0755
303-427-5700
303-427-5725 fax
www.wanco.com