



SPARE PARTS LIST

SURFACE PREPARATION EQUIPMENT

PG 400, 2018-02

Go to Discount-Equipment.com to order your parts



A PG 400
Motor

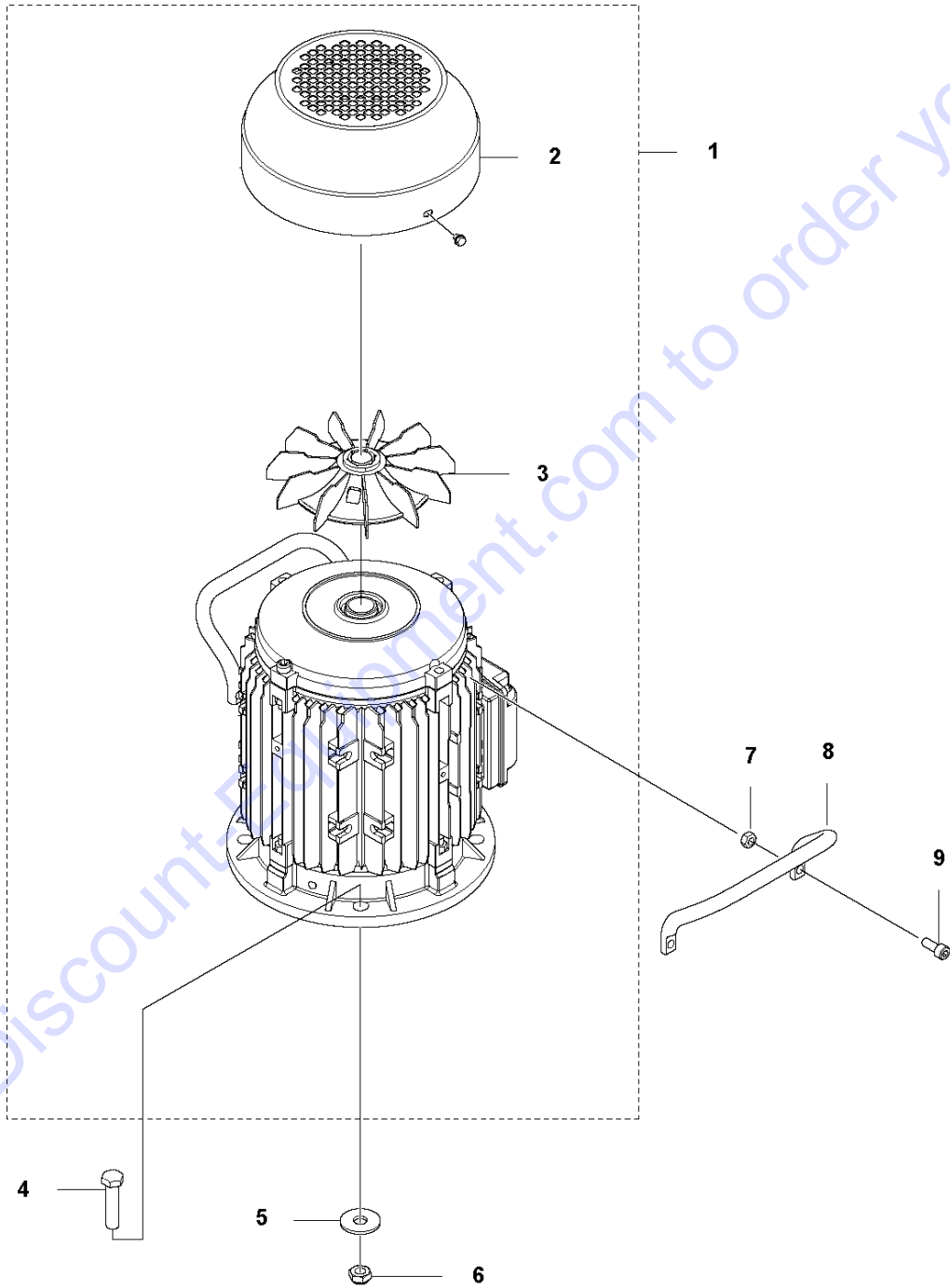

Ref	Part No	Description	Remark	QTY	KIT
1	589 68 63-01	MOTOR	3-Phase	1	
1	585 30 22-02	MOTOR	1-Phase 60Hz	1	
2	594 00 99-01	FAN COVER	3-Phase	1	1
2	587 17 46-02	FAN COVER	1-Phase 60Hz	1	1
3	594 01 00-01	FAN	3-Phase	1	1
3	587 17 47-02	FAN	1-Phase 60Hz	1	1
4	725 25 42-71	SCREW EHHM		4	
5	734 11 80-41	WASHER		4	
6	732 25 22-01	HEXAGON LOCKING NUT		4	
7	731 23 18-01	HEXAGON NUT		4	
8	585 42 33-02	HANDLE		2	
9	725 54 51-01	SCREW IHSCM		4	

Go to Discount-Equipment.com to order your parts

B PG 400
Grinding Head

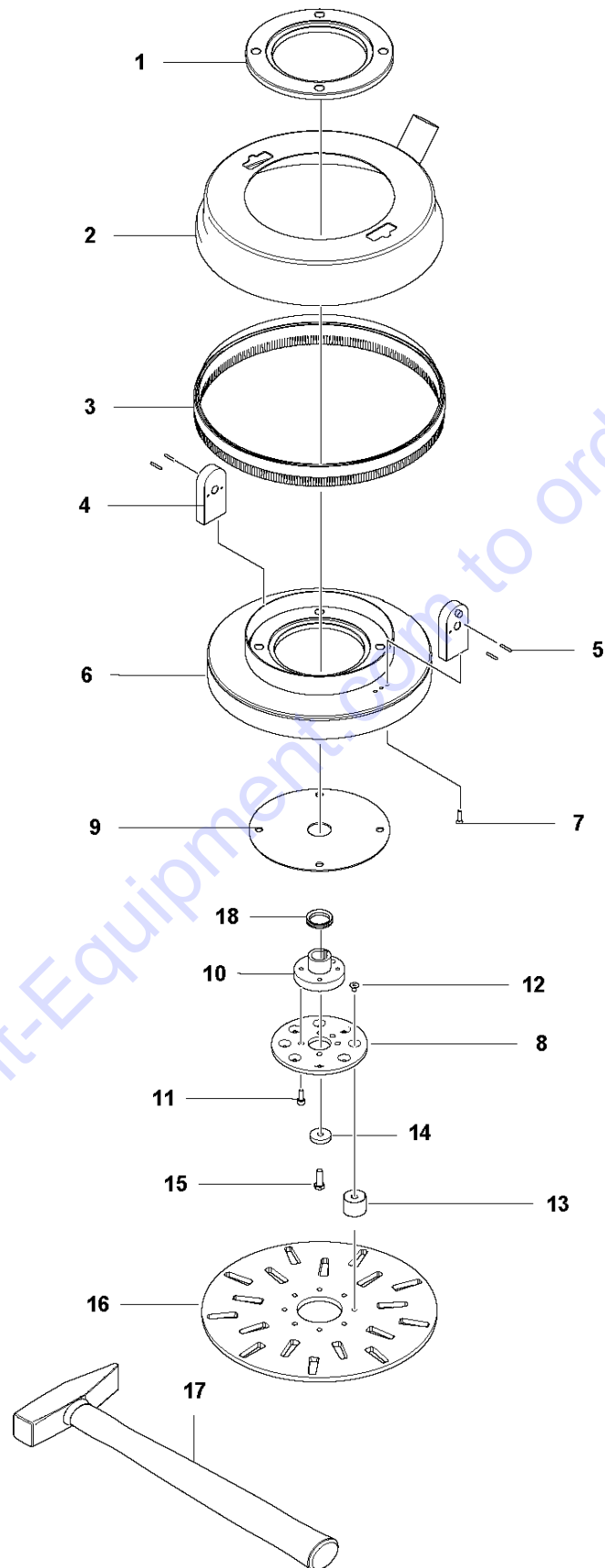

Ref	Part No	Description	Remark	QTY KIT
1	585 08 33-03	SPACER		1
2	585 15 96-01	DUST COVER		1
3	585 13 84-04	BRUSH		1
4	585 54 03-01	BRACKET		2
4	585 54 03-02	BRACKET	HDX variant only	2
5	721 42 59-01	SPRING PIN		4
6	585 15 90-01	MOUNTING PLATE		1
7	725 63 72-51	SCREW IHCSFM		6
8	510 23 43-02	ATTACHMENT PLATE		1
9	589 79 75-01	SEALING PLATE		1
10	585 51 47-01	HUB		1
11	725 54 51-55	SCREW IHSCM		4
12	725 64 47-55	SCREW IHCSFM		8
13	510 21 31-01	DAMPER		8
14	510 23 51-01	WASHER		1
15	725 24 95-71	SCREW EHHM		1
16	587 79 58-01	DISC		1
17	522 03 97-01	HAMMER		1
18	589 92 58-01	V-RING		1

Go to Discount-Equipment.com to order your parts

C PG 400
Chassi

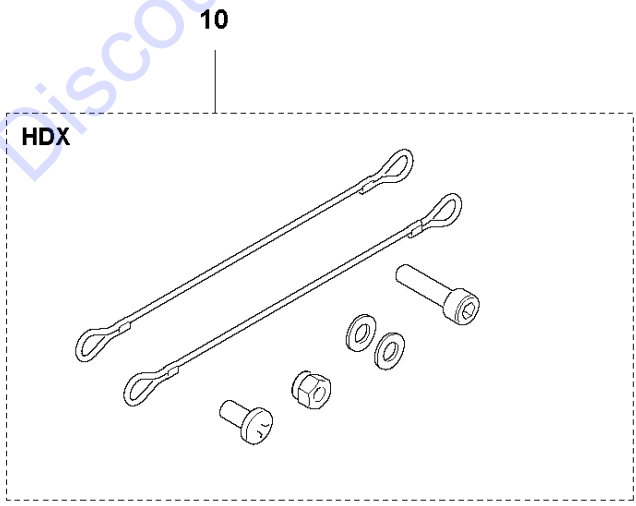
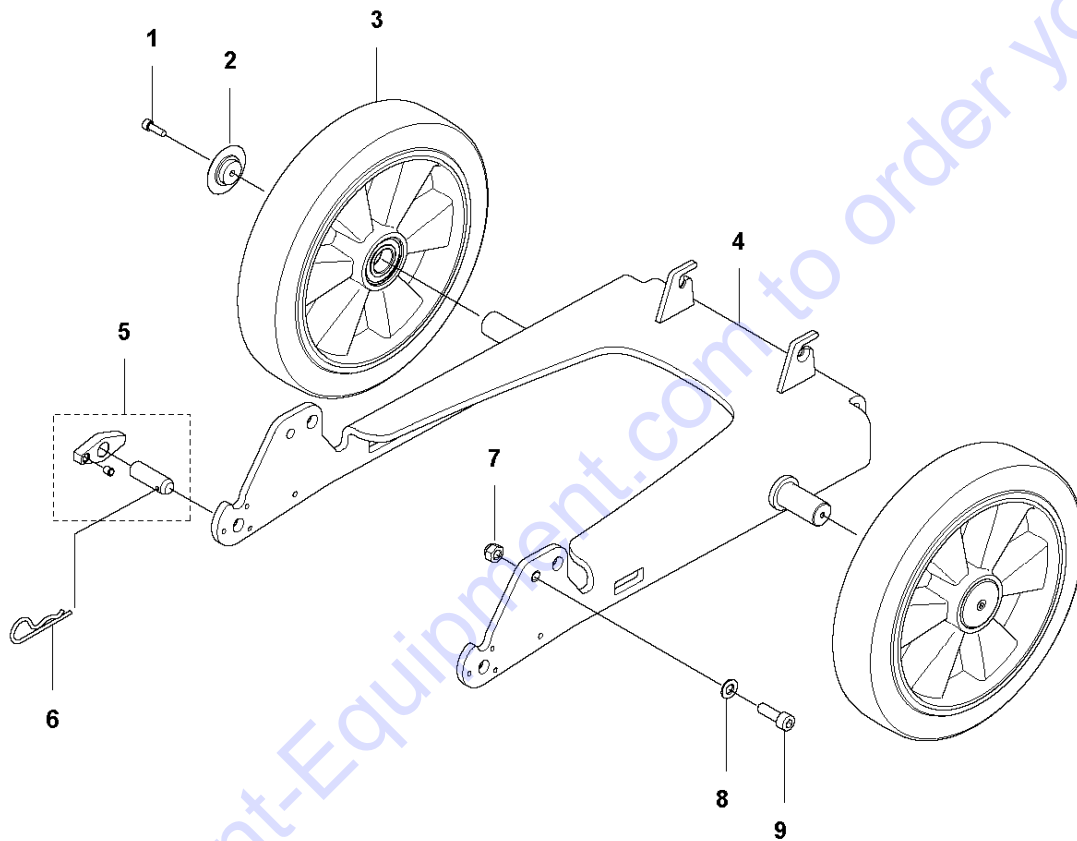

Go to Discount-Equipment.com to order your parts

Ref	Part No	Description	Remark	QTY KIT
1	725 53 68-51	SCREW IHSCM		2
2	575 39 51-01	WASHER		2
3	502 54 50-01	WHEEL		2
4	585 10 91-02	CHASSIS		1
5	586 99 17-02	BOLT		2
5	586 99 17-04	BOLT	HDX variant only	2
6	721 68 02-51	SPRING COTTER		2
7	732 25 20-01	HEXAGON LOCKING NUT		2
8	734 11 72-01	WASHER		2
9	725 54 95-01	SCREW IHSCM		2
10	590 54 00-01	WIRE	HDX variant only	1

Go to Discount-Equipment.com to order your parts

D PG 400
Frame

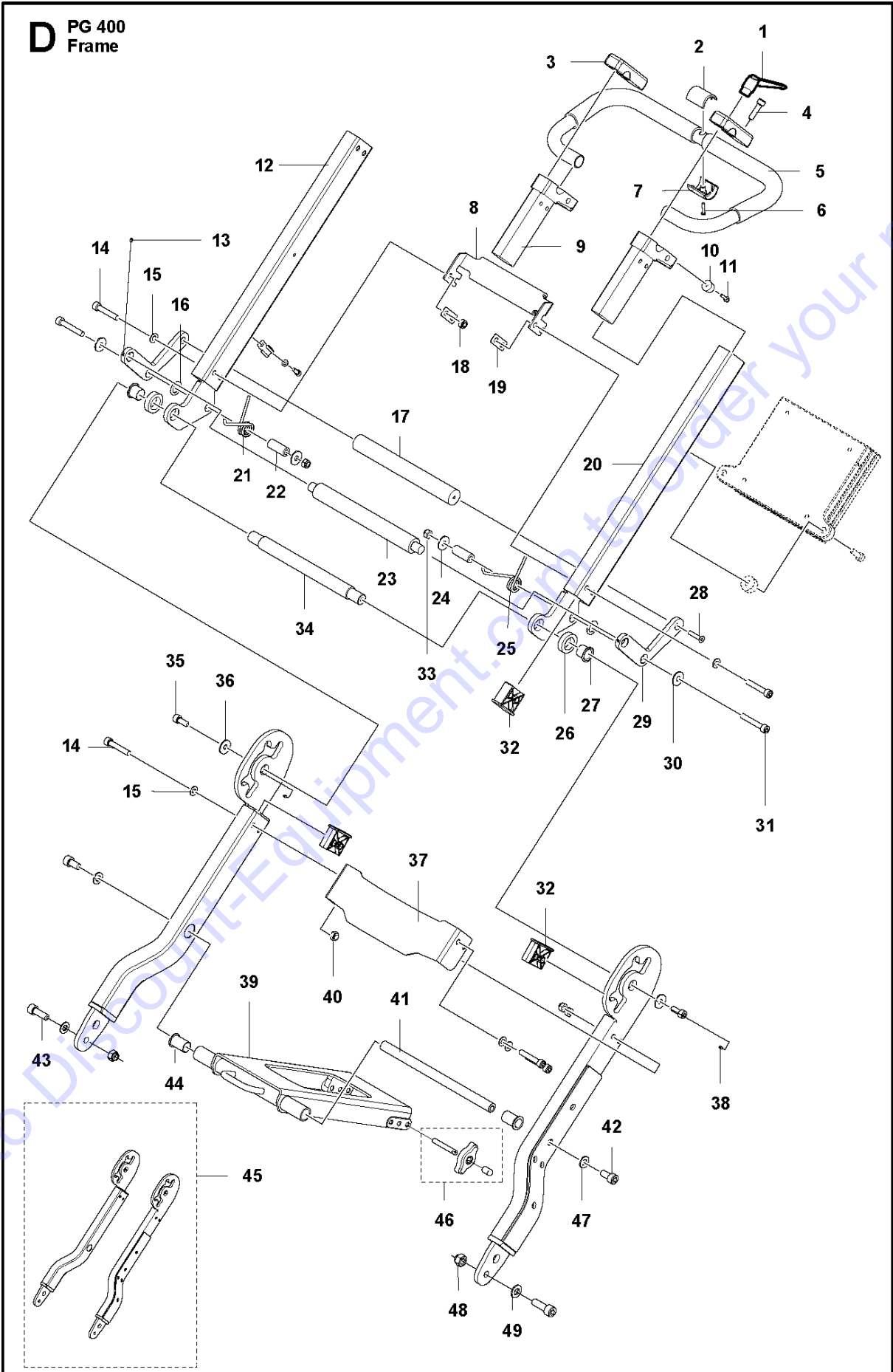

Ref	Part No	Description	Remark	QTY KIT
1	590 37 37-01	LOCKING HANDLE		2
2	587 15 85-01	COVER		1
3	585 51 66-01	BRACKET		2
4	725 54 55-01	SCREW IHSCM		2
5	585 14 40-01	HANDLE		1
6	729 52 61-71	SCREW CRPANT		1
7	587 15 86-01	COVER		1
8	585 38 28-01	BRACKET		1
9	589 83 77-01	BRACKET		2
10	585 51 68-01	RUBBER SHOE		2
11	725 52 95-01	SCREW IHSCM		2
12	585 57 35-11	FORK		1
13	728 82 85-01	SCREW IHSETM		6
14	725 54 60-01	SCREW IHSCM		8
15	734 11 63-01	WASHER		8
16	585 41 62-01	WASHER		2
17	585 13 37-01	HANDLE		1
18	732 21 18-01	LOCK NUT		8
19	585 38 31-01	WASHER		2
20	585 57 35-12	FORK		1
21	585 41 73-01	SPRING		1
22	585 38 33-02	SLEEVE		2
23	585 13 38-01	ROD		1
24	734 11 65-41	WASHER		4
25	585 41 61-01	SPRING		1
26	585 13 35-01	SPACER		2
27	585 41 60-01	BUSH		2
28	725 63 74-51	SCREW		2
29	585 13 33-01	PLATE		2
30	734 11 65-41	WASHER		4
31	725 54 61-01	SCREW IHSCM		2
32	585 13 29-01	SPACER		4
33	732 21 18-01	LOCK NUT		2
34	585 13 38-01	ROD		1
35	725 54 51-01	SCREW IHSCM		2
36	734 11 65-41	WASHER		2
37	585 38 30-01	BRACKET		1
37	585 38 30-03	BRACKET	HDX version only	1
38	728 82 85-01	SCREW IHSETM		6
39	585 10 97-02	SUPPORT		1
40	732 25 18-01	HEXAGON LOCKING NUT		10
41	585 12 90-02	TUBE		1
42	725 54 91-01	SCREW IHSCM		2
43	725 54 95-01	SCREW IHSCM		2
44	585 12 91-01	BUSH		2
45	593 89 71-02	FRAME TUBE		1
46	590 47 22-01	WING KNOB		2
47	734 11 72-01	WASHER		2
48	732 25 20-01	HEXAGON LOCKING NUT		2
49	734 11 72-01	WASHER		2

Go to DiscountEquipment.com to order your parts

D PG 400
Weight Pack

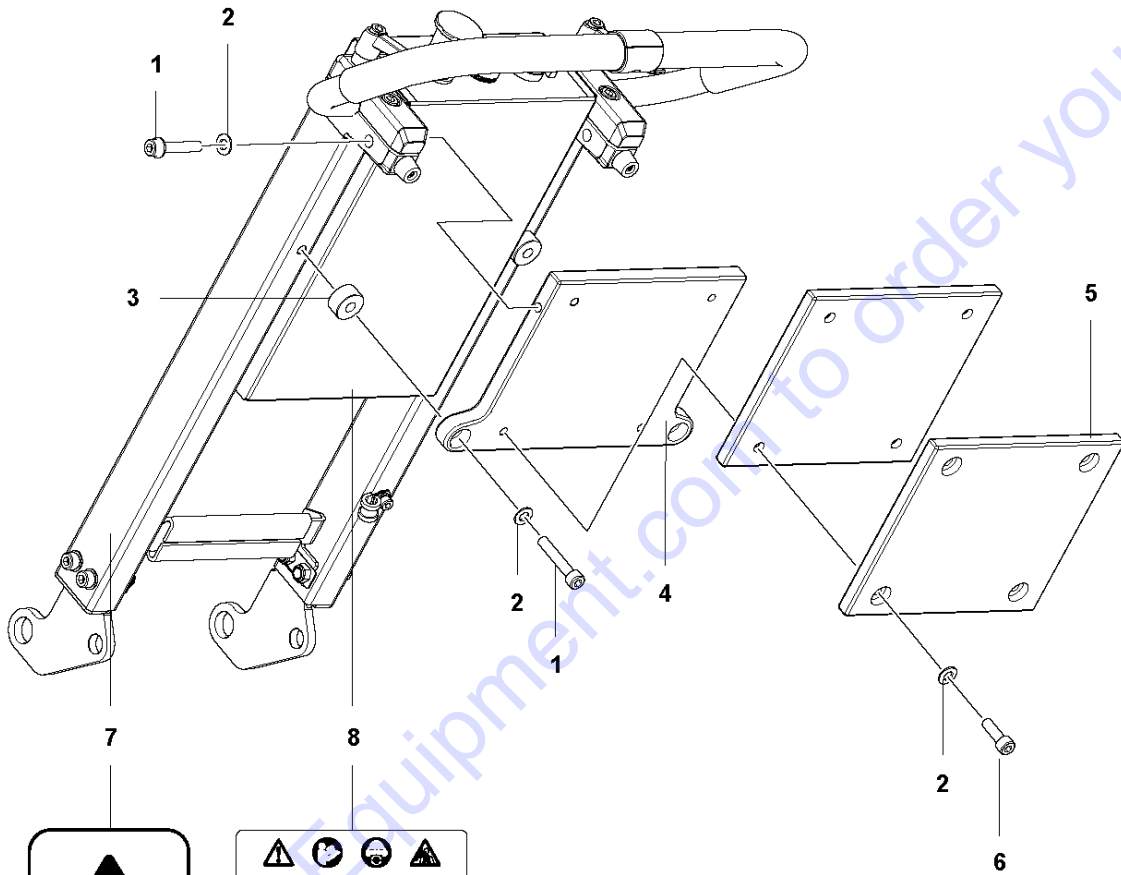

WARNING
CAUTION
To reduce risk of injury from moving parts, unplug before servicing.
ATTENTION
Afin de réduire le risque de blessures, débranchez avant toute réparation.
AVERTISSEMENT
Débranchez le circuit d'alimentation avant le nettoyage ou l'entretien.



Go to DiscountEquipment.com to order your parts

Ref	Part No	Description	Remark	QTY KIT
1	725 54 60-01	SCREW IHSCM		4
2	734 11 63-01	WASHER		8
3	590 20 34-01	BUSHING		2
4	589 83 71-01	COUNTERWEIGHT		1
5	589 83 72-01	COUNTERWEIGHT		1
6	725 54 53-01	SCREW IHSCM		4
7	582 34 72-01	DECAL		1
8	590 51 83-01	DECAL		1
8	590 51 84-01	DECAL		1

Go to Discount-Equipment.com to order your parts

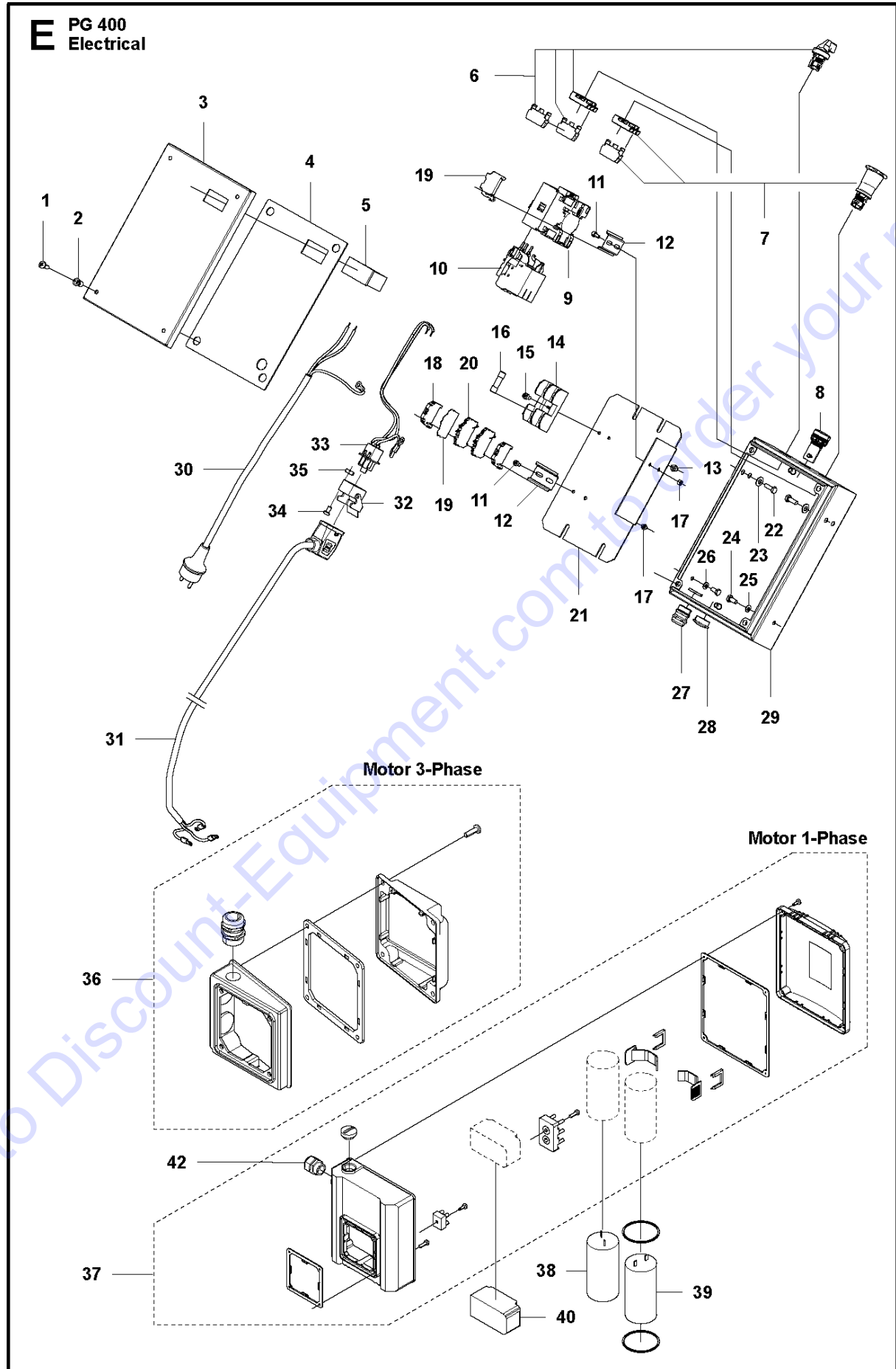

Ref	Part No	Description	Remark	QTY KIT
1	724 13 68-51	SCREW CRPANM		4
2	521 88 66-01	RIVET		4
3	586 47 43-01	LID		1
3	586 47 43-03	LID	HDX variant only	1
4	586 46 70-02	SEALING		1
5	584 29 63-01	HOUR METER		1
6	586 99 15-01	SWITCH KIT		1
7	586 99 16-01	SWITCH KIT		1
8	584 29 71-01	LAMP	230V	1
8	584 29 71-03	LAMP	415V	1
9	585 36 58-03	CONTACTOR	400-480V, 50/60Hz	1
9	585 36 58-01	CONTACTOR	200-230V, 50/60Hz	1
10	584 29 78-02	RELAY	3 phase, 400-480V	1
10	580 62 35-02	PROTECTION	3 phase, 220-240V	1
10	580 62 35-01	PROTECTION	1 phase, 220-240V, 60Hz	1
11	725 53 25-01	SCREW IHSCM		4
12	522 74 70-01	RAIL		2
13	731 23 16-01	HEXAGON NUT		1
14	525 88 26-01	FUSE HOLDER		1
15	725 53 64-55	SCREW IHSCM		1
16	525 63 81-01	FUSE		2
17	732 25 14-01	HEXAGON LOCKING NUT		4
18	585 36 61-05	TERMINAL BLOCK		3
19	585 36 61-03	TERMINAL BLOCK		1
19	585 36 61-07	TERMINAL BLOCK	US, 1 phase, 100-120V	1
20	585 61 35-01	TERMINAL BLOCK	2pcs for 1ph and 3 pcs for 3ph machines	2
20	585 36 61-01	TERMINAL BLOCK	US, 1 phase, 120V	2
21	590 07 58-01	MOUNTING PLATE		1
22	725 24 51-71	SCREW EHHM		4
23	734 11 63-01	WASHER		4
24	725 23 66-51	HEXAGONAL SCREW M6X12		2
25	734 11 52-01	WASHER		1
26	735 21 53-01	LOCKWASHER		1
27	510 43 17-01	CABLE GROMMET		1
28	586 58 69-01	PLUG		1
28	586 58 69-02	PLUG	US, 1 phase	1
29	582 50 69-03	ELECTRONIC BOX		1
29	582 50 69-04	ELECTRONIC BOX	HDX variant only	1
30	586 23 78-01	CABLE	3 phase	1
30	586 23 78-02	CABLE	AUS, 3 phase	1
30	586 23 78-03	CABLE	US, 3 phase, 240V	1
30	586 23 78-05	CABLE	JP	1
30	586 23 68-12	CABLE	US, 1 phase, 230V	1
30	586 23 68-08	CABLE	BR	1
31	585 63 81-07	CABLE	3 phase	1
31	585 63 81-10	CABLE	US/CAN, 1 phase	1
32	585 36 66-05	CONNECTOR		1
33	590 50 35-01	CONNECTOR		1
34	725 52 24-01	SCREW		2
35	732 25 10-01	HEXAGON LOCKING NUT		2
36	587 17 39-02	ELECTRONIC BOX	3 phase	1
37	587 17 39-01	ELECTRONIC BOX	1 phase	1
38	587 17 45-03	CAPACITOR	230V, 50/60Hz, run capacitor 45uF	1
39	587 17 44-04	CAPACITOR	230V, 50/60Hz, start capacitor 250uF	1
40	587 17 43-04	SWITCH	1 ph, 230V, 60Hz	1
42	587 17 42-01	GROMMET		1

PARTS FINDER

**Search Website
by Part Number**



**Search Manual
Library For Parts
Manual & Lookup Part
Numbers – Purchase
or Request Quote**

Search Manuals

Enter your information to help us find the right parts manual for your machine.

* Brand:

* Model:

* Serial:

* Part Number:

SEARCH

**Can't Find Part or
Manual? Request Help
by Manufacturer,
Model & Description**

Parts Order Form

Please fill in the following information to help us find the right part for your machine.

Manufacturer:	<input type="text"/>
Model:	<input type="text"/>
Description:	<input type="text"/>
Part Number:	<input type="text"/>
Quantity:	<input type="text"/>
Notes:	<input type="text"/>

Submit

Discount-Equipment.com is your online resource for quality parts & equipment.

Florida: **561-964-4949** Outside Florida TOLL FREE: **877-690-3101**

Need parts?

Click on this link: <http://www.discount-equipment.com/category/5443-parts/> and choose one of the options to help get the right parts and equipment you are looking for. Please have the machine model and serial number available in order to help us get you the correct parts. If you don't find the part on the website or on one of the online manuals, please fill out the request form and one of our experienced staff members will get back to you with a quote for the right part that your machine needs.

We sell worldwide for the brands: Genie, Terex, JLG, MultiQuip, Mikasa, Essick, Whiteman, Mayco, Toro Stone, Diamond Products, Generac Magnum, Airman, Haulotte, Barreto, Power Blanket, Nifty Lift, Atlas Copco, Chicago Pneumatic, Allmand, Miller Curber, Skyjack, Lull, Skytrak, Tsurumi, Husquvarna Target, Stow, Wacker, Sakai, Mi-T-M, Sullair, Basic, Dynapac, MBW, Weber, Bartell, Bennar Newman, Haulotte, Ditch Runner, Menegotti, Morrison, Contec, Buddy, Crown, Edco, Wyco, Bomag, Laymor, EZ Trench, Bil-Jax, F.S. Curtis, Gehl Pavers, Heli, Honda, ICS/PowerGrit, IHI, Partner, Imer, Clipper, MMD, Koshin, Rice, CH&E, General Equipment, Amida, Coleman, NAC, Gradall, Square Shooter, Kent, Stanley, Tamco, Toku, Hatz, Kohler, Robin, Wisconsin, Northrock, Oztec, Toker TK, Rol-Air, APT, Wylie, Ingersoll Rand / Doosan, Innovatech, Con X, Ammann, Mecalac, Makinex, Smith Surface Prep, Small Line, Wanco, Yanmar