

OPERATION MANUAL



Mikasa SERIES
MODEL MVHeR60
REVERSIBLE PLATE COMPACTOR
(HONDA GXE2.0H DC POWER UNIT
HONDA DP72104Z BATTERY)

Revision #0 (02/09/22)

To find the latest revision of this publication or associated parts manual, visit our website at:
www.discount-equipment.com



THIS MANUAL MUST ACCOMPANY THE EQUIPMENT AT ALL TIMES.

TO PURCHASE THIS PRODUCT PLEASE CONTACT US



**Equipment Financing and
Extended Warranties Available**



**Discount-Equipment.com is your online resource for
commercial and industrial quality parts and equipment sales.**

561-964-4949

visit us on line @ www.discount-equipment.com

Select an option below to find your Equipment

Search by Manufacturer

Search by Product Type

Request a Quote

We sell worldwide for the brands: Genie, Terex, JLG, MultiQuip, Mikasa, Essick, Whiteman, Mayco, Toro Stone, Diamond Products, Generac Magnum, Airman, Haulotte, Barreto, Power Blanket, Nifty Lift, Atlas Copco, Chicago Pneumatic, Allmand, Miller Curber, Skyjack, Lull, Skytrak, Tsurumi, Husquvarna Target, Stow, Wacker, Sakai, Mi-T-M, Sullair, Basic, Dynapac, MBW, Weber, Bartell, Bennar Newman, Haulotte, Ditch Runner, Menegotti, Morrison, Contec, Buddy, Crown, Edco, Wyco, Bomag, Laymor, EZ Trench, Bil-Jax, F.S. Curtis, Gehl Pavers, Heli, Honda, ICS/PowerGrit, IHI, Partner, Imer, Clipper, MMD, Koshin, Rice, CH&E, General Equipment, Amida, Coleman, NAC, Gradall, Square Shooter, Kent, Stanley, Tamco, Toku, Hatz, Kohler, Robin, Wisconsin, Northrock, Oztec, Toker TK, Rol-Air, APT, Wylie, Ingersoll Rand / Doosan, Innovatech, Con X, Ammann, Mecalac, Makinex, Smith Surface Prep, Small Line, Wanco, Yanmar

**MVHeR60
Plate Compactor**

Proposition 65 Warning 2
Safety Information 4-6
Specifications 8-9
Dimensions..... 10
General Information..... 11
Components 12-13
Inspection 14-15
Wheel Kit (Optional) 16-17
Operation..... 18-19
Maintenance 20-21
Long Term Storage 22
Troubleshooting 23
Wiring Diagram..... 24

NOTICE

Specifications and part numbers are subject to change without notice.

SAFETY INFORMATION

Do not operate or service the equipment before reading the entire manual. Safety precautions should be followed at all times when operating this equipment. Failure to read and understand the safety messages and operating instructions could result in injury to yourself and others.



SAFETY MESSAGES

The four safety messages shown below will inform you about potential hazards that could injure you or others. The safety messages specifically address the level of exposure to the operator and are preceded by one of four words: **DANGER**, **WARNING**, **CAUTION** or **NOTICE**.

SAFETY SYMBOLS

! DANGER

Indicates a hazardous situation which, if not avoided, **WILL** result in **DEATH** or **SERIOUS INJURY**.

! WARNING

Indicates a hazardous situation which, if not avoided, **COULD** result in **DEATH** or **SERIOUS INJURY**.







! CAUTION

Indicates a hazardous situation which, if not avoided, **COULD** result in **MINOR** or **MODERATE INJURY**.

NOTICE

Addresses practices not related to personal injury.

Potential hazards associated with the operation of this equipment will be referenced with hazard symbols which may appear throughout this manual in conjunction with safety messages.

Symbol	Safety Hazard
	Lethal exhaust gas hazards
	Explosive fuel hazards
	Burn hazards
	Respiratory hazards
	Accidental starting hazards
	Eye and hearing hazards
	Rotating parts hazards

SAFETY INFORMATION

GENERAL SAFETY

CAUTION

- **NEVER** operate this equipment without proper protective clothing, shatterproof glasses, respiratory protection, hearing protection, steel-toed boots and other protective devices required by the job or city and state regulations.



- **NEVER** operate this equipment when not feeling well due to fatigue, illness or when under medication.



- **NEVER** operate this equipment under the influence of drugs or alcohol.



- **ALWAYS** check the equipment for loosened threads or bolts before starting.
- **DO NOT** use the equipment for any purpose other than its intended purposes or applications.
- **ALWAYS** clear the work area of any debris, tools, etc. that would constitute a hazard while the equipment is in operation.

NOTICE

- This equipment should only be operated by trained and qualified personnel 18 years of age and older.
- Whenever necessary, replace nameplate, operation and safety decals when they become difficult read.
- Manufacturer does not assume responsibility for any accident due to equipment modifications. Unauthorized equipment modification will void all warranties.
- **NEVER** use accessories or attachments that are not recommended by Multiquip for this equipment. Damage to the equipment and/or injury to user may result.
- **ALWAYS** know the location of the nearest **fire extinguisher**.
- **ALWAYS** know the location of the nearest **first aid kit**.
- **ALWAYS** know the location of the nearest phone or **keep a phone on the job site**. Also, know the phone numbers of the nearest **ambulance, doctor and fire department**. This information will be invaluable in the case of an emergency.



SAFETY INFORMATION

COMPACTOR SAFETY

DANGER

- **NEVER** operate the equipment in an explosive atmosphere or near combustible materials. An explosion or fire could result causing severe **bodily harm or even death.**



WARNING

- **NEVER** disconnect any **emergency or safety devices.** These devices are intended for operator safety. Disconnection of these devices can cause severe injury, bodily harm or even death. Disconnection of any of these devices will void all warranties.

CAUTION

- **NEVER** lubricate components or attempt service on a running machine.

NOTICE

- **ALWAYS** keep the machine in proper running condition.
- Fix damage to machine and replace any broken parts immediately.
- **ALWAYS** store equipment properly when it is not being used. Equipment should be stored in a clean, dry location out of the reach of children and unauthorized personnel.

BATTERY SAFETY

CAUTION

- Remove or attach battery in a clear and flat location without any combustible materials nearby.
- After attaching the battery, make sure that the battery hook and fastener are securely attached.

DC POWER UNIT

CAUTION

- **DO NOT** touch the DC power unit during work or soon after work, because it is very hot.

TRANSPORTING SAFETY

CAUTION

- **NEVER** allow any person or animal to stand underneath the equipment while lifting.

NOTICE

- Before lifting, make sure that the equipment parts (hook and vibration insulator) are not damaged and screws are not loose or missing.
- Always make sure crane or lifting device has been properly secured to the lifting bail (hook) of the equipment.
- **ALWAYS** shutdown DC power before transporting.
- **NEVER** lift the equipment with power on.
- Use adequate lifting cable (wire or rope) of sufficient strength.
- Use one point suspension hook and lift straight upwards.
- **DO NOT** lift machine to unnecessary heights.
- **ALWAYS** tie down equipment during transport by securing the equipment with rope.

ENVIRONMENTAL SAFETY

NOTICE

- Dispose of hazardous waste properly. Examples of potentially hazardous waste are used motor oil, fuel and fuel filters.
- **DO NOT** use food or plastic containers to dispose of hazardous waste.
- **DO NOT** pour waste, oil or fuel directly onto the ground, down a drain or into any water source.



SPECIFICATIONS

Table 1. MVHeR60 Specifications

Centrifugal Force	2,698 lbf (12 kN)
Vibration Frequency	6500 vpm (108 Hz)
Lubrication Oil	API Service Categories SE or higher SAE 10W-30
Plate Size (L x W)	18.9 x 13.8 in (480 x 350 mm)
Maximum Travel Speed	0 to 78.7 ft/min (0 to 24 m/min)
Operating Weight	179 lbs. (81 kg)
Vibrating Oil Capacity	0.211 quarts (0.20 liters)
Water Tank Capacity	8.98 quarts (8.5 liters)
V-belt Size	RPF3310
Rated Operating Time	Approximately 25 - 35 min/1.6 kW

Table 2. DC Power Unit Specifications

Model	Honda GXE2.OH
Type	Three-phase brushless DC motor
Weight (without battery)	40.8 lbs. (18.5 kg)
Maximum Output	2.4 HP (1.8 KW) @ 3600 R.P.M.
Voltage	72 V

Table 3. Battery Specifications

Model	Honda DP72104Z
Type	Rechargeable Lithium Ion Battery
Dimensions (L x Wx H)	9.2 x 10.6 x 5.9 in (233 x 268 x 150 mm)
Weight	14.1 lbs. (6.4 kg)
Voltage	72 V
Charging Temperature Range	41 - 86 °F (5 - 30 °C)
Operating Temperature Range	41 - 104 °F (5 - 40 °C)
Storage Temperature Range	23 - 86 °F (-5 - 30 °C)

SPECIFICATIONS

Table 4. Battery Charger Specifications

Model	Honda CV7285Z
Dimensions (L x Wx H)	10.5 x 13.9 x 9.7 in (266 x 352 x 247 mm)
Weight	24.2 lbs. (11 kg)
Cable Length	78.7 in (2000 mm)
Input Voltage	100-240 VAC
Input Frequency	50/60 Hz
Output Voltage	82.8 VDC
Charging Temperature Range	41 - 86 °F (5 - 30 °C)
Charging Time: 80% 100%	1 hour 1.5 hours

Table 5. Noise and Vibration Emissions

Measured Sound Power Level in dB(A)	104
Guaranteed Sound Power Level in dB(A)	105
Guaranteed Sound Pressure Level at Operator Station in dB(A)	89
Hand-Arm Vibration in m/s ²	4.6

NOTES:

1. Products are tested for sound pressure level in accordance with European Directives 2000/14/EC and 2005/88/EC, relating to Noise Emission in the Environment by equipment for use outdoors.
2. Products are tested for hand/arm vibration (HAV) level in accordance with European Directives 2002/44/EC and EN500-4 and ISO 5349-1:2001, ISO 5349-2:2001.

DIMENSIONS

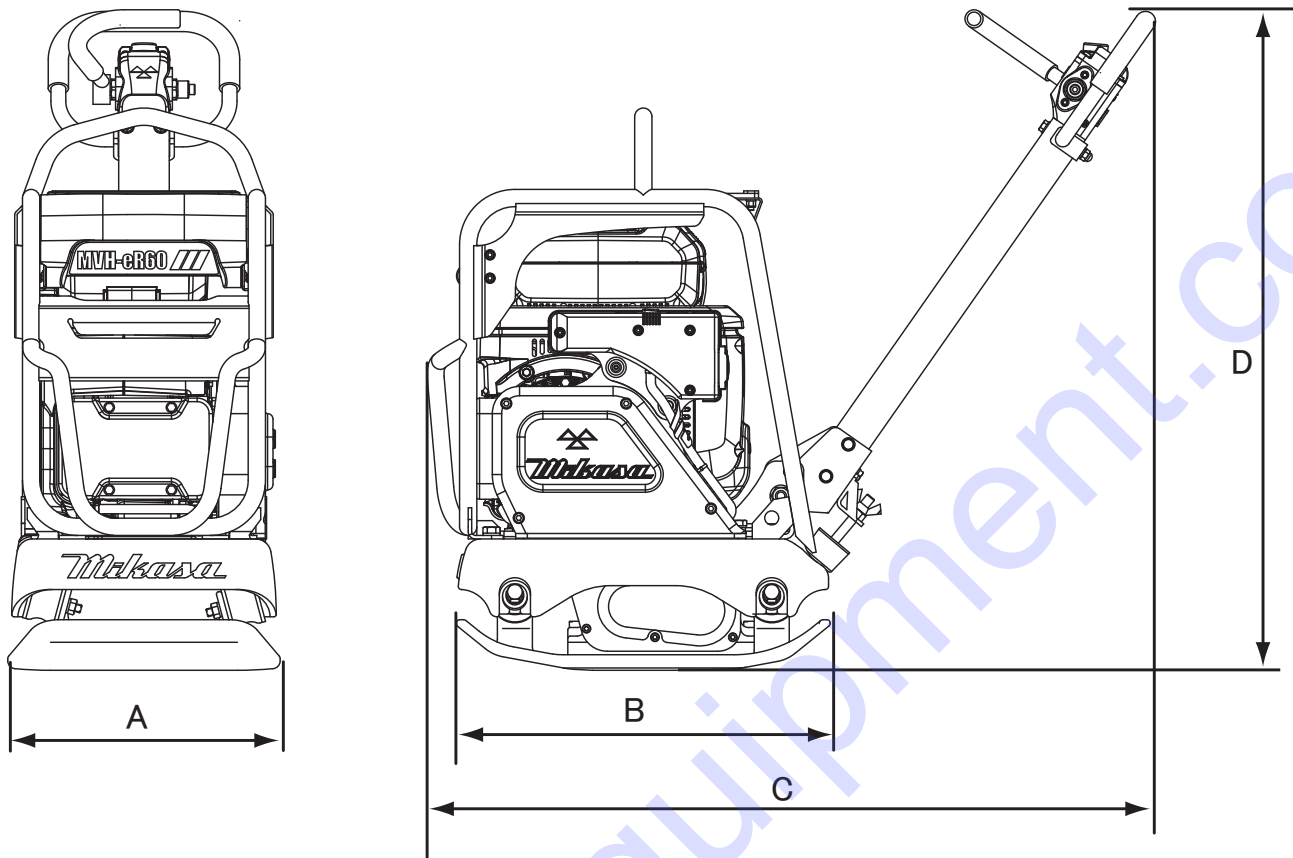

Figure 1. MVHer60 Dimensions

Table 6. Dimensions

Reference	Description	Measurement
A	Width of Plate	13.8 in (350 mm)
B	Length of Plate	18.9 in (480 mm)
C	Length (including handle)	37.0 in (940 mm)
D	Height (including handle)	37.2 in. (945 mm)

GENERAL INFORMATION

DEFINITION OF PLATE COMPACTOR

The Mikasa MVHeR60 is a walk-behind, reversible plate compactor designed for the compaction of sand, mixed soils and asphalt. This plate compactor is a powerful compacting tool capable of applying a tremendous force in consecutive high frequency vibrations to a soil surface. Its applications include soil compacting for road, embankments and reservoirs as well as backfilling for gas pipelines, water pipelines and cable installation work.

The upper part of the machine consists of an engine, handle, belt cover and guard frame. The upper part of the machine is fixed to the compacting board of the lower part via an anti-vibration rubber. The lower part of the machine consists of a compacting board and a vibrator. Inside the vibrator, there are two pendulums. The phase of those pendulums is changed by hydraulic pressure. The hydraulic cylinder for the vibrator is connected with a hydraulic hose to the hydraulic pump, which is directly connected to the drive lever.

VIBRATORY PLATES

The vibratory plates produce low amplitude high frequency vibrations, designed to compact granular soils and asphalt.

The resulting vibrations cause forward and reverse motion. The engine and handle are vibration-isolated from the vibrating plate. The heavier the plate, the more compaction force it generates.

FREQUENCY/SPEED

The compactor's vibrating plate has a frequency of 6,500 vpm (vibrations per minute).

DC POWER UNIT

The plate compactor is equipped with a Honda GXE2.OH 3-phase brushless DC motor.

BATTERY and BATTERY CHARGER

THE MVHeR60 uses a Honda DP72104Z rechargeable lithium ion battery and a Honda DV7285Z battery charger.

WATER TANK

An optional water tank can be used with this compactor. The tank provides lubrication to the base plate when compacting asphalt and may be used for dust control in dry work environments.

COMPONENTS

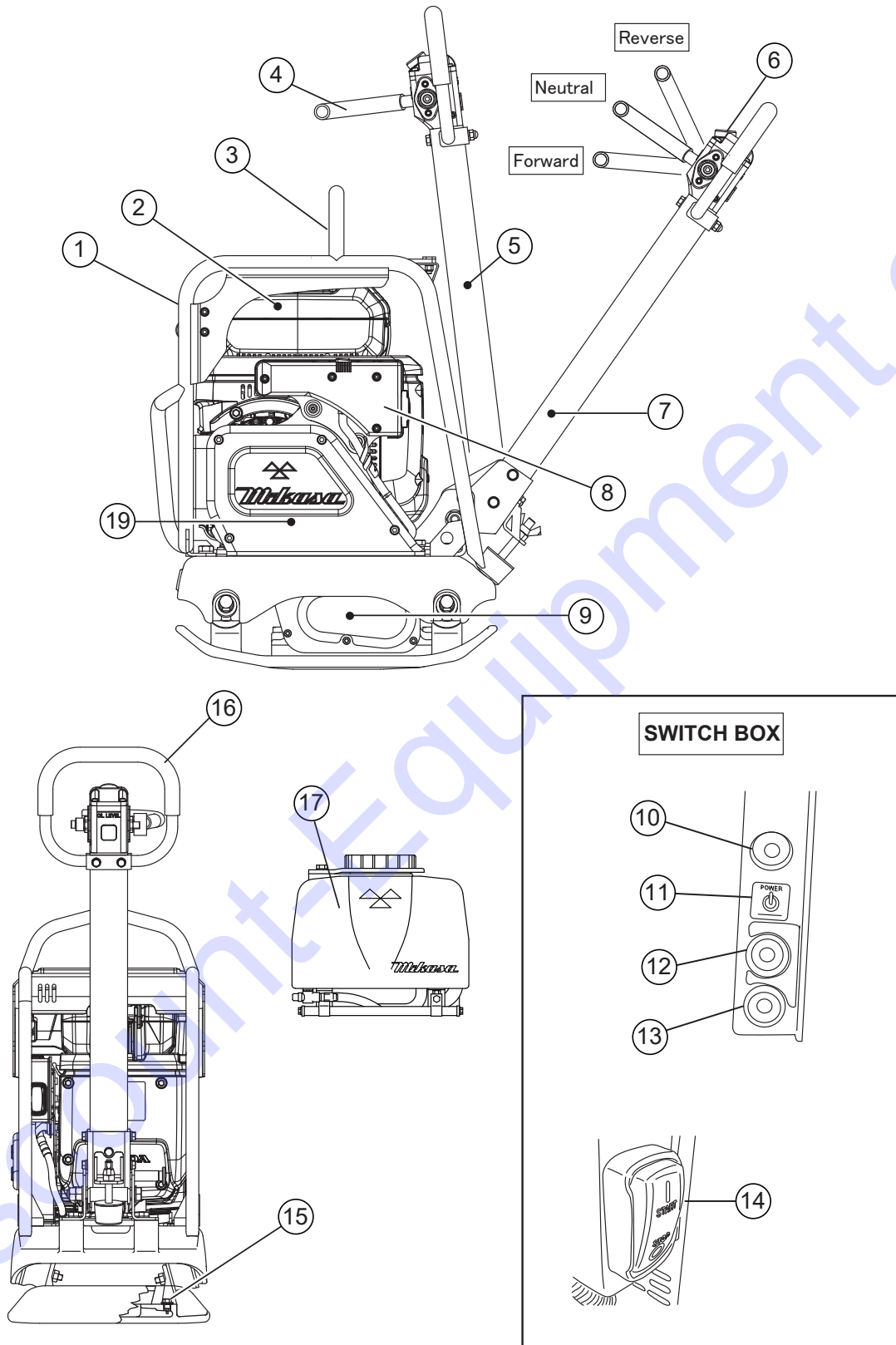

Figure 2. MVHer60 Controls and Components

COMPONENTS

Figure 2 shows the location of the basic controls and components of the MVHeR60 Plate Compactor. The function of each control is described below:

1. **Guard Frame** — Protects the components of the plate compactor.
2. **Battery Pack** — Rechargeable Lithium Ion Battery.
3. **Lifting Bale** — When lifting of the compactor is required either by forklift, crane, etc., tie rope or chain around this lifting point.
4. **Travel Lever** — Push the lever forward, the compactor will move in a forward direction, pull the lever backwards, the compactor will move in backwards direction. Placing the lever in the middle (midway) will cause the compactor not to move (neutral).
5. **Handle (Storing Position)** — When operating the compactor use this handle bar to maneuver the compactor.
6. **Breather Cap** — Remove this cap to bleed (remove air) the hydraulic system.
7. **Handle (Working Position)** — When operating the compactor use this handle bar to maneuver the compactor.
8. **Switch Box** — contains buttons and indicators to operate compactor.
9. **Vibration Case** — Encloses the eccentric, gears and counter weights.
10. **Power Indicator** — Lights green when the power button is pressed.
11. **Power Button** — Used to turn power on and off.
12. **Alert Indicator** — Lights orange to indicate something is wrong with compactor.
13. **Error Indicator** — Lights red when an error is detected.
14. **Start/Stop Button** — Used to start and stop unit.
15. **Vibrator Oil Gauge** — Shows how much oil is in vibration case..
16. **Grip** — Hold to control handle.
17. **Water Tank (Optional)** — Used when your application requires sprinkling. *Do not fill with diesel fuel or gasoline as this creates both a safety and environmental hazard!*

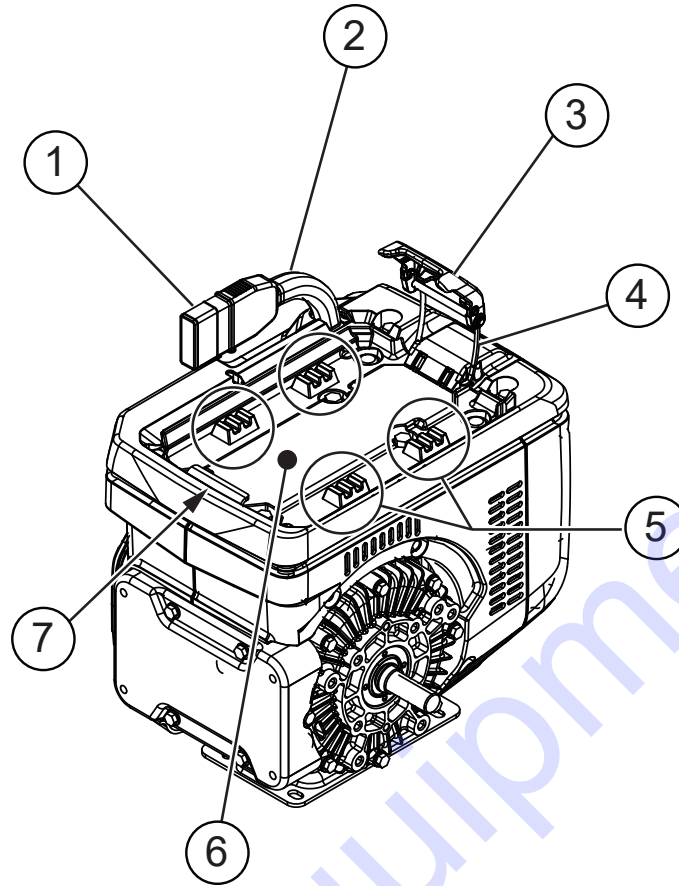

Figure 3. Power Unit Components

1. **Battery Connector Cap** — Protects the battery connector on the power cable.
2. **Power Cable** — Connects the compactor to the battery pack for power.
3. **Battery Fastener Lever** — Locks the battery fastener.
4. **Battery Fastener** — Used to hook the battery pack in place.
5. **Battery Support** — Where the battery pack sits on the battery tray.
6. **Battery Tray** — Holds the battery pack.
7. **Battery Hook** — Attaches the battery pack to the battery tray.

BEFORE STARTING

1. Read safety instructions at the beginning of manual.
2. Clean the compactor, removing dirt and dust.
3. Check fastening nuts and bolts for tightness. Loosened screws or bolts due to vibration, could lead to unexpected accident.
4. Make sure that the guard hook, belt cover and shock absorbers are not damaged. If they are damaged, replace new ones.
5. Replace any missing or damaged safety and operation decals.

VIBRATOR OIL CHECK

1. To check the oil level, place the plate compactor on a level surface with the power off.
2. Remove the oil plug and visually check the oil level (Figure 4).

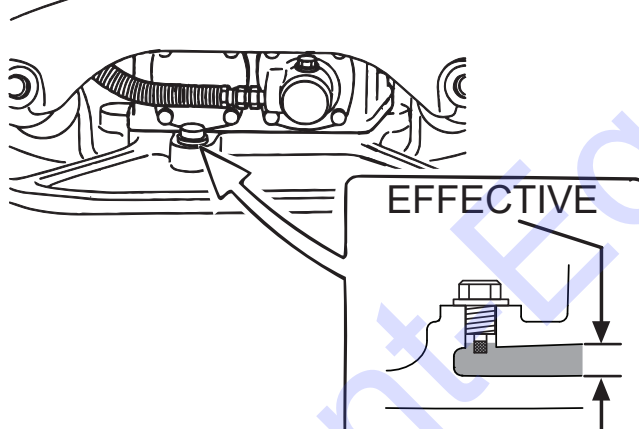

Figure 4. Oil Check

3. If the oil level is low, fill up to the oil plug with the recommended oil type (Table 7). Maximum oil capacity is 0.211 quarts (0.20 liters).

Table 7. Oil Type		
Season	Temperature	Oil Type
Summer	25° C or higher	SAE 10W-30
Spring/Fall	25° C - 10° C	SAE 10W-30/20
Winter	0° C	SAE 10W-10

BATTERY PACK AND BATTERY CHARGER

NOTICE

Follow the owner's manual provided with the battery pack and battery charger for the following operations:

- Charging and Charge Level
- Cleaning
- Storage
- Disposal

NOTICE

Follow the owner's manual provided with the DC power unit when attaching and removing the battery pack.

Attaching the Battery Pack

1. Make sure there are no debris or dirt on the battery tray (Figure 5).

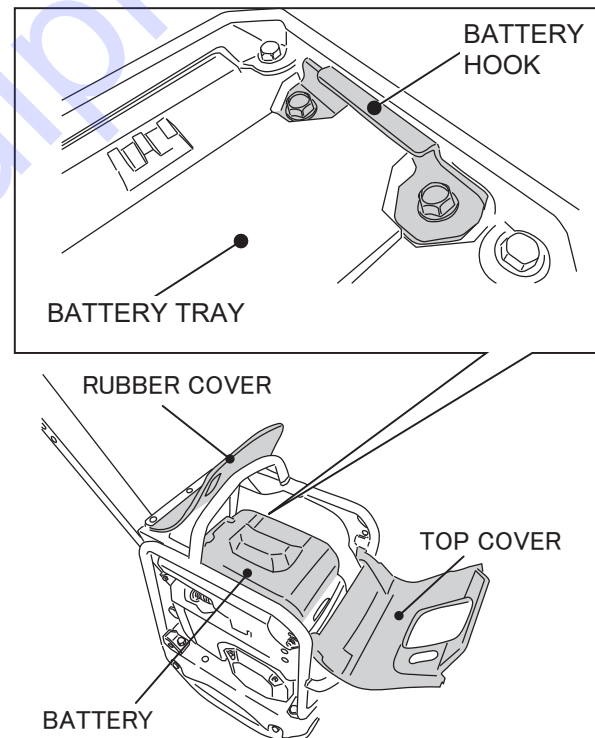

Figure 5. Battery Tray

2. Tilt the battery pack and insert its claw into the battery hook.
3. Push down the battery pack and hook the battery fastener to it (Figure 6).
4. Push the battery fastener lever up and lock the battery pack. Be careful not to catch your fingers.

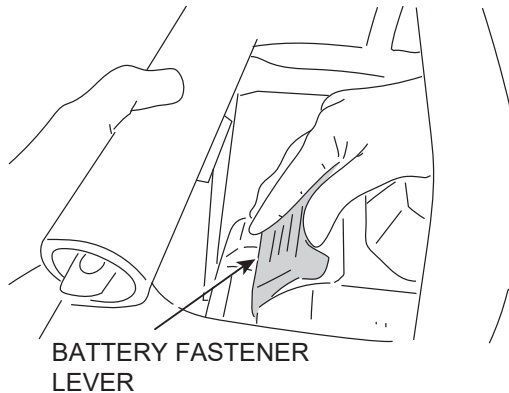

Figure 6. Battery Fastener Lever

5. Remove the battery connector cap from the power cable (Figure 7).

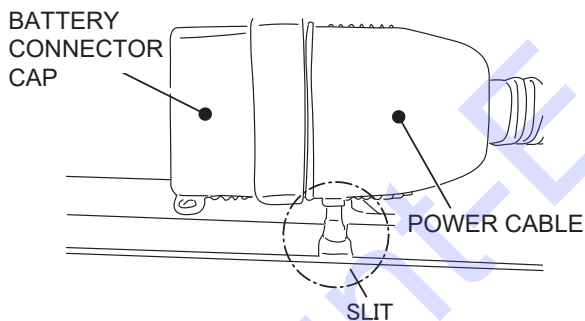

Figure 7. Battery Connector

6. Connect the power cable to the battery connector of the battery pack (Figure 8).

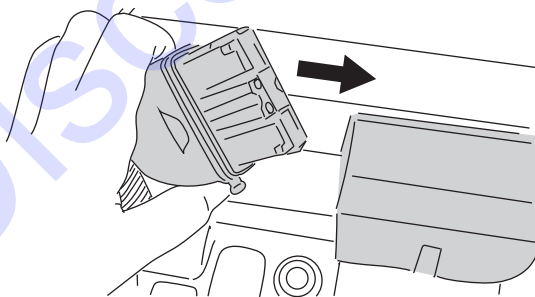

Figure 8. Connecting Power Cable

7. After attaching the battery pack, make sure the battery hook and fastener are securely attached.

Removing the Battery Pack

1. Remove the power cable from the battery pack.
2. Pull the battery fastener down to unlock, tilt the battery pack up, and pull the battery pack claw out from the battery hook.
3. Remove the battery pack.
4. Attach the battery connector cap to the power cable.

CAUTION

Failure to understand the operation of the plate compactor could result in severe damage to the unit or personal injury.

STARTUP

Refer to Figure 9 for location of buttons and indicators on the control panel.

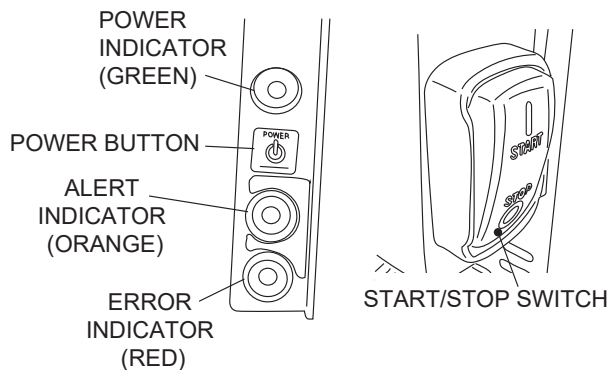

Figure 9. Switch Box

When starting the plate compactor, perform the following:

1. Press STOP on the START/STOP switch.
2. Press the POWER button.
3. All the indicators should illuminate for a few seconds, and then only the POWER indicator remains illuminated.

OPERATION

1. Hold the handle firmly.
2. Press START on the START/STOP switch to start moving forward by starting the DC Power Unit.
3. To stop, press STOP on the START/STOP switch. The DC Power Unit stops and the POWER indicator turns off.
4. Use the forward and reverse travel lever to make the machine move backward and forward. When the lever is pushed forward, the machine moves forward; when pulled backward, the machine moves backward. At neutral, the machine vibrates staying at the same location.

NOTICE

- If the POWER button is pressed when the START/STOP switch is in the START position, the POWER indicator remains off and the ALERT indicator flashes. In this case, the DC Power Unit cannot start. Press STOP on the START/STOP switch then press the POWER button.
- It may take some time for the indicators to light after the POWER button is pressed. If the indicators do not light, press the POWER button again.
- If the DC Power Unit is not operated for about one minute after the POWER button is pressed, the POWER indicator turns off. Press the POWER button again to start the DC Power Unit.

CAUTION

- DO NOT use this machine on ground that is harder than the machine can handle, or for driving pilings or tamping rock beds.
- Furthermore, use of the machine on sloping ground, such as the side of an embankment, may make the machine unstable and can cause an accident. It can also result in premature machine wear due to uneven loads on the machine.
- Only use the machine for compacting earth and sand, soil, and asphalt.
- DO NOT use the machine for other types of jobs.
- In cold weather, the compactor can be warmed up by pressing START and STOP on the START/STOP switch several times until the plate compactor operates smoothly.
- Do not operate continuously when the travel lever is in neutral position, operate at the travel lever is forward or backward.

STOPPING THE DC POWER UNIT

1. Press STOP on the START/STOP switch
2. The DC Power Unit stops and the POWER indicator turns off.

CAUTION

You can also stop the DC Power unit by pressing the POWER button, but it may take some time to stop.

WATER TANK (OPTIONAL)

1. If your unit is equipped with the water tank and your application requires sprinkling work, open the cock of water tank(Figure 10).

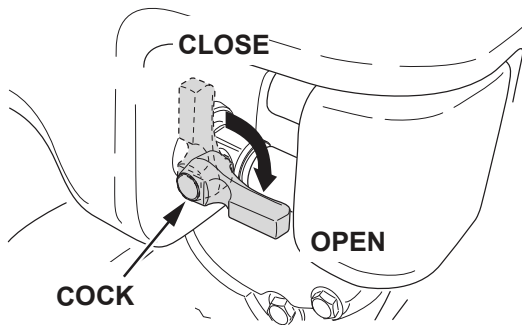

Figure 10. Water Tank Cock (Open)

2. When stopping sprinkling work, close the cock of water tank (Figure 11).

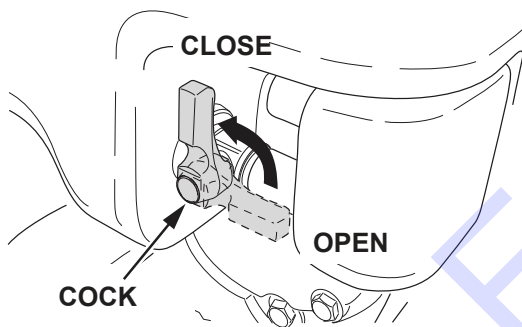

Figure 11. Water Tank Cock (Close)

CAUTION

Inspection and other services should always be carried out on hard and level ground with the engine shut down.

INSPECTION AND MAINTENANCE TABLES

To make sure your plate compactor is always in good working condition before using, carry out the maintenance inspection in accordance with Table 8.

Table 8. Machine Inspection

Item	Frequency of Inspection
Loose or Missing Screws	Every 8 hours (daily)
Damaged Parts	Every 8 hours (daily)
Function of Controlling System Part	Every 100 hours
Vibrator and Hydraulic Oil Check	Every 8 hours (daily)
Vibrator Oil Replacement	Every 300 hours
Hydraulic Oil Replacement	Every 300 hour
V-belt (clutch) Check	Every 200 hours

NOTICE

These inspection intervals are for operation under normal conditions. Adjust your inspection intervals based on the number of hours the plate compactor has been in use, and the type of working conditions it is being used.

DAILY INSPECTION

1. Check for leakage of fuel or oil.
2. Check for loose screws including tightness. See Table 9 (Tightening Torque) for retightening.

Table 9. Tightening Torque (kg cm)

Material	Diameter							
	6mm	8mm	10mm	12mm	14mm	16mm	18mm	20mm
4T	70	150	300	500	750	1,100	1,400	2,000
6-8T	100	250	500	800	1,300	2,000	2,700	3,800
11T	150	400	800	1,200	2,000	2,900	4,200	5,600
*	100	300-350	650-700					

* (for aluminum counterpart)
(Threads in use with this machine are all right-handed)
Material and quality of material is marked on each bolt and screw.

3. Remove soil and clean the bottom of compaction plate.

V-BELT CHECK

CAUTION

NEVER attempt to check the V-belt with the power on. Severe injury can occur if your hand (Figure 12) gets caught between the V-belt and the clutch. Always use safety gloves.

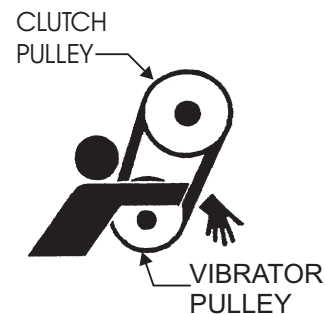

Figure 12. V-Belt Hazard

1. The V-belt tension is proper if the V-belt bends 10 to 15 mm (Figure 13) when depressed with finger midway between the clutch and vibration pulley shafts.

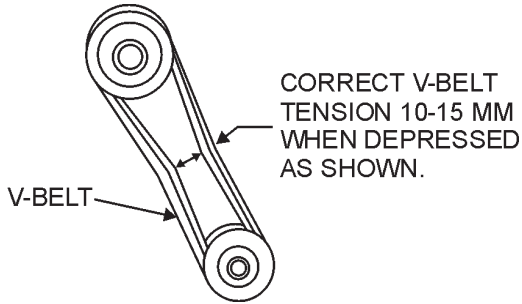

Figure 13. V-Belt Tension

2. A loose V-belt will decrease the power transmission output causing reduced compaction and premature wear of the belt.
3. If the V-belt becomes worn or loose, replace it.

NOTICE

Whenever the compactor's vibration becomes weak or lost during normal operation, regardless of operation hours, check the V-belt and clutch immediately.

VIBRATOR OIL LEVEL CHECK

1. When changing the vibrator oil, remove the drain plug.
2. In every 300 hours of operation, replace oil (capacity - 0.211 quart (0.20 liter).
 - * Use engine oil 10W-30 for this lubrication.

NOTICE

Always clean the area around the vibrator oil level check hole before removing oil check plug. This will prevent dirt and debris from entering the system.

CHECKING HYDRAULIC OIL

CAUTION

The level of the hydraulic oil in the hand pump should always be at OIL LEVEL. If the level is higher, the oil bursts out from the breather plug

NOTICE

Be careful not to let dust enter inside the hand pump.

1. Check the hydraulic oil at every 100 hours of operation.
2. Place the handle bar in vertical position.
3. Remove the breather plug at the top of the hydraulic hand pump to see if the hydraulic oil is at the specified level. See Figure 14.

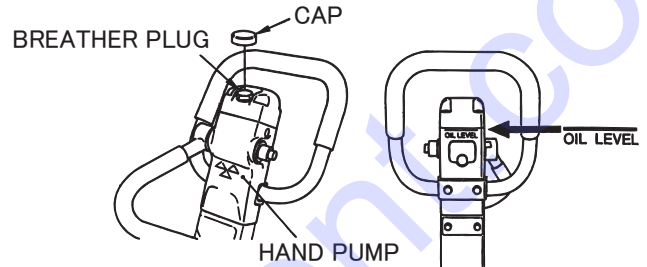

Figure 14. Hydraulic Oil Check

CHANGING HYDRAULIC OIL

4. Remove the hand pump plug cap, then remove the breather plug with a 24 mm wrench. Remove the hydraulic hose that is in the vibrator cylinder. Set the lever to the forward motion to drain the hydraulic oil in the pump.
5. After the hydraulic oil is drained, install the hydraulic hose to the vibrator.
6. Pour hydraulic oil from the hand pump breather plug attachment hole.
7. Remove the air releasing plug of vibrator cylinder. Then oil will come out from the air releasing plug. After air bubbles stop coming out, attach the plug. Tighten securely.
8. Attach the hand pump breather plug, put on the plug cap. After making sure the hydraulic oil in the pump is at OIL LEVEL, attach the breather plug.

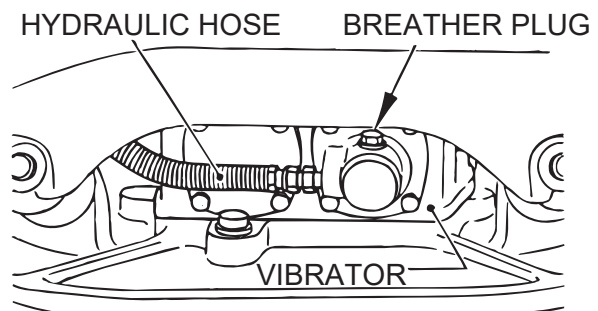

Figure 15. Changing Hydraulic Oil

MAINTENANCE/LONG TERM STORAGE

CHECKING SWITCH BOX

1. Check that the assembly of switch box is not loose (Figure 16).
2. If switch box is loose, it may fall off or be damaged.
3. If loose, remove the switch box and replace the grommet installed on switch box panel with a new one.

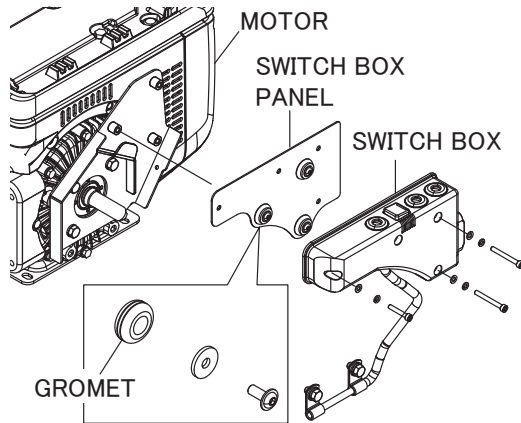

Figure 16. Checking Switch Box

PLATE COMPACTOR STORAGE

For storage of the plate compactor for over 30 days, the following is required:

1. Completely drain oil from the vibrating case.
2. Clean entire plate compactor, especially the bottom plate removing all dirt and foreign matter.
3. Cover plate compactor with plastic covering or equivalent and store in a clean, dry place.

TROUBLESHOOTING

Troubleshooting (Compactor)		
Symptom	Possible Problem	Solution
Travel speed low and vibration weak.	Clutch slips?	Adjust or replace clutch.
	V-belt slips?	Adjust or replace V-belt.
	Excessive oil in vibrator?	Fill to correct level.
	Trouble in vibrator internals?	Check vibrator assembly for any worn or defective parts, replace any defective parts.
	Aeration in hydraulic oil for for travel reversing system?	Purge air in hydraulic oil. (Bleed plug)
	Engine speed incorrect?	Set engine speed to correct RPM.
Travels forward or backward but unable to switch direction.	Hydraulic pump problems?	Check hydraulic pump.
	Direction Control Lever installation wrong?	Correct installation of IDirection Control Lever.
	Broken or defective oil hose?	Replace oil hose.
	Aeration in hydraulic oil?	Purge air in hydraulic oil. (Bleed plug)
	Excessive oil in reversing system?	Fill to correct level.
	Hydraulic pump clogged with trash?	Clean valve inside hydraulic pump.
	Cylinder piston bearing failure?	Check piston bearing in cylinder for leakage.
Does not travel in forward or reverse	V-belt disengaged or slips?	Engage V-belt, adjust or replace.
	Clutch slips?	Adjust clutch, replace if necessary.
	Vibrator locks?	Check vibrator and correct problem.
	Cylinder piston bearing failure?	Check piston bearing in cylinder for leakage at USH packing.
Direction Control Lever operating resistance for reverse is high.	Piston inside hydraulic pump not moving smoothly?	Adjust or replace.
	Vibrator cylinder piston does not move smoothly	Adjust or replace.

NOTICE

For troubleshooting of the DC Power Unit, Battery Pack and Battery Charger, please refer to respective owner's manual.

WIRING DIAGRAM

