

# OPERATION MANUAL



*Mikasa* **SERIES**  
**MODEL MTe55**  
**RAMMER**  
**(HONDA GXE2.0S 2.4 HP ELECTRIC MOTOR)**

Revision #1 (12/15/22)

To find the latest revision of this publication or associated parts manual, visit our website at:  
[www.discount-equipment.com](http://www.discount-equipment.com)



**THIS MANUAL MUST ACCOMPANY THE EQUIPMENT AT ALL TIMES.**

**TO PURCHASE THIS PRODUCT PLEASE CONTACT US**



**Equipment Financing and  
Extended Warranties Available**



**Discount-Equipment.com is your online resource for  
commercial and industrial quality parts and equipment sales.**

**561-964-4949**

**visit us on line @ [www.discount-equipment.com](http://www.discount-equipment.com)**

Select an option below to find your Equipment

**Search by Manufacturer**

**Search by Product Type**

**Request a Quote**

We sell worldwide for the brands: Genie, Terex, JLG, MultiQuip, Mikasa, Essick, Whiteman, Mayco, Toro Stone, Diamond Products, Generac Magnum, Airman, Haulotte, Barreto, Power Blanket, Nifty Lift, Atlas Copco, Chicago Pneumatic, Allmand, Miller Curber, Skyjack, Lull, Skytrak, Tsurumi, Husquvarna Target, Stow, Wacker, Sakai, Mi-T-M, Sullair, Basic, Dynapac, MBW, Weber, Bartell, Bennar Newman, Haulotte, Ditch Runner, Menegotti, Morrison, Contec, Buddy, Crown, Edco, Wyco, Bomag, Laymor, EZ Trench, Bil-Jax, F.S. Curtis, Gehl Pavers, Heli, Honda, ICS/PowerGrit, IHI, Partner, Imer, Clipper, MMD, Koshin, Rice, CH&E, General Equipment, Amida, Coleman, NAC, Gradall, Square Shooter, Kent, Stanley, Tamco, Toku, Hatz, Kohler, Robin, Wisconsin, Northrock, Oztec, Toker TK, Rol-Air, APT, Wylie, Ingersoll Rand / Doosan, Innovatech, Con X, Ammann, Mecalac, Makinex, Smith Surface Prep, Small Line, Wanco, Yanmar

**PROPOSITION 65 WARNING**

---



# TABLE OF CONTENTS

---

## **MTe55 Rammer**

Proposition 65 Warning .....	2
Safety Information .....	5-7
Specifications .....	8-9
Noise And Vibration Emissions.....	9
Dimensions.....	10
General Information.....	11
Components .....	12-13
Transporting And Lifting.....	14
Inspection .....	15-16
Operation.....	17-18
Maintenance .....	19
Troubleshooting .....	20

### **NOTICE**

Specifications and part numbers are subject to change without notice.

# SAFETY INFORMATION

Do not operate or service the equipment before reading the entire manual. Safety precautions should be followed at all times when operating this equipment. Failure to read and understand the safety messages and operating instructions could result in injury to yourself and others.







## SAFETY MESSAGES

The four safety messages shown below will inform you about potential hazards that could injure you or others. The safety messages specifically address the level of exposure to the operator and are preceded by one of four words: **DANGER**, **WARNING**, **CAUTION** or **NOTICE**.

## SAFETY SYMBOLS

 <b>DANGER</b>
Indicates a hazardous situation which, if not avoided, <b>WILL</b> result in <b>DEATH</b> or <b>SERIOUS INJURY</b> .
 <b>WARNING</b>
Indicates a hazardous situation which, if not avoided, <b>COULD</b> result in <b>DEATH</b> or <b>SERIOUS INJURY</b> .
 <b>CAUTION</b>
Indicates a hazardous situation which, if not avoided, <b>COULD</b> result in <b>MINOR</b> or <b>MODERATE INJURY</b> .
<b>NOTICE</b>
Addresses practices not related to personal injury.

Potential hazards associated with the operation of this equipment will be referenced with hazard symbols which may appear throughout this manual in conjunction with safety messages.

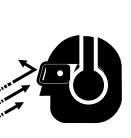
Symbol	Safety Hazard
	Lethal exhaust gas hazards
	Explosive fuel hazards
	Burn hazards
	Respiratory hazards
	Accidental starting hazards
	Eye and hearing hazards

# SAFETY INFORMATION

## GENERAL SAFETY

### CAUTION

- **NEVER** operate this equipment without proper protective clothing, shatterproof glasses, respiratory protection, hearing protection, steel-toed boots and other protective devices required by the job or city and state regulations.





- **NEVER** operate this equipment when not feeling well due to fatigue, illness or when under medication. 
- **NEVER** operate this equipment under the influence of drugs or alcohol.



- **ALWAYS** check the equipment for loosened threads or bolts before starting.
- **DO NOT** use the equipment for any purpose other than its intended purposes or applications.

### NOTICE

- This equipment should only be operated by trained and qualified personnel 18 years of age and older.
- Whenever necessary, replace nameplate, operation and safety decals when they become difficult read.
- Manufacturer does not assume responsibility for any accident due to equipment modifications. Unauthorized equipment modification will void all warranties.
- **NEVER** use accessories or attachments that are not recommended by Multiquip for this equipment. Damage to the equipment and/or injury to user may result.
- **ALWAYS** know the location of the nearest fire extinguisher. 
- **ALWAYS** know the location of the nearest first aid kit. 

- **ALWAYS** know the location of the nearest phone or **keep a phone on the job site**. Also, know the phone numbers of the nearest **ambulance, doctor** and **fire department**. This information will be invaluable in the case of an emergency.

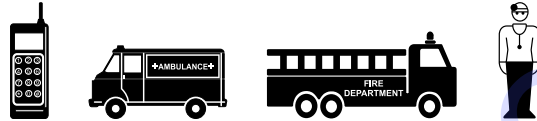

## RAMMER SAFETY

### DANGER

- **NEVER** operate the equipment in an explosive atmosphere or near combustible materials. An explosion or fire could result causing severe **bodily harm or even death**. 

### WARNING

- **NEVER** disconnect any **emergency or safety devices**. These devices are intended for operator safety. Disconnection of these devices can cause severe injury, bodily harm or even death. Disconnection of any of these devices will void all warranties.
- **DO NOT** use this machine on ground that is harder than the machine can handle, or for driving pilings or tamping rock beds. Furthermore, use of the machine on sloping ground, such as the side of an embankment, may make the machine unstable and can cause an accident. It can also result in premature machine wear due to uneven loads on the machine.

Use the machine with confidence for tamping earth and sand, soil, gravel, and asphalt. **DO NOT** use the machine for other types of jobs.

### CAUTION

- **NEVER** lubricate components or attempt service on a running machine.

### NOTICE

- **ALWAYS** keep the machine in proper running condition.
- Fix damage to machine and replace any broken parts immediately.
- **ALWAYS** store equipment properly when it is not being used. Equipment should be stored in a clean, dry location out of the reach of children and unauthorized personnel.

# SAFETY INFORMATION

## BATTERY SAFETY

### CAUTION

- Remove or attach battery in a clear and flat location without any combustible materials nearby.
- After attaching the battery, make sure that the battery hook and fastener are securely attached.

## DC POWER UNIT

### CAUTION

- **DO NOT** touch the DC power unit during work or soon after work, because it is very hot.

## TRANSPORTING SAFETY

### CAUTION

- **NEVER** allow any person or animal to stand underneath the equipment while lifting.

### NOTICE

- Before lifting, make sure that the equipment parts (hook and vibration insulator) are not damaged and screws are not loose or missing.
- Always make sure crane or lifting device has been properly secured to the lifting bail (hook) of the equipment.
- **ALWAYS** shutdown engine before transporting.
- **NEVER** lift the equipment while the DC power is on.
- Remove the battery pack before transporting or storing the machine.
- Use adequate lifting cable (wire or rope) of sufficient strength.
- Use one point suspension hook and lift straight upwards.
- **DO NOT** lift machine to unnecessary heights.
- **ALWAYS** tie down equipment during transport by securing the equipment with rope.
- Never allow any person or animal to stand underneath the equipment while lifting.

## ENVIRONMENTAL SAFETY

### NOTICE

- Dispose of hazardous waste properly. Examples of potentially hazardous waste are used motor oil, fuel and fuel filters. 
- **DO NOT** use food or plastic containers to dispose of hazardous waste.
- **DO NOT** pour waste, oil or fuel directly onto the ground, down a drain or into any water source.

# SPECIFICATIONS

**Table 1. Rammer Specifications**

Overall Height	40.9 in. (1040 mm)
Overall Width	13.8 in. (350 mm)
Over Length	28.2 in. (715 mm)
Plate Size (W x L)	10.4 x 13.4 in. (265 x 340 mm)
Lubrication Oil	AP Service Category SE or higher SAE10W-30
Lubrication Oil Capacity	0.62 qt. (0.66 liter)
No. of Impacts Per Minute: Rated speed (3,600 rpm) Medium speed (3,600 rpm) Low speed (3,600 rpm)	689 BPM (11.5 Hz) 632 BPM (10.5 Hz) 574 BPM (9.6 Hz)
Impact Force	1984-2425 lbf (8.8-10.8 kN)
Shoe Jump Height	1.18-2.76 in (30-70 mm)
Operating Weight	165 lbs. (75 kg)

**Table 2. DC Power Unit Specifications**

Model	Honda GXE2.OS
Type	Three-phase brushless DC motor
Weight (without battery) Controller Motor	15.7 lbs. (7.1 kg) 19.2 lbs. (8.7 kg)
Cooling System	Forced Air
Maximum Output	2.4 HP (1.8 KW) @ 3600 R.P.M.
Voltage	72 V

**Table 3. Battery Specifications**

Model	Honda DP72104Z
Type	Rechargeable Lithium Ion Battery
Dimensions (L x Wx H)	9.2 x 10.6 x 5.9 in (233 x 268 x 150 mm)
Weight	14.1 lbs. (6.4 kg)
Voltage	72 V
Charging Temperature Range	41 - 86 °F (5 - 30 °C)
Operating Temperature Range	41 - 104 °F (5 - 40 °C)
Storage Temperature Range	23 - 86 °F (-5 - 30 °C)



# SPECIFICATIONS/NOISE AND VIBRATION EMISSIONS

**Table 4. Battery Charger Specifications**

Model	Honda CV7285Z
Dimensions (L x Wx H)	10.5 x 13.9 x 9.7 in (266 x 352 x 247 mm)
Weight	24.2 lbs. (11 kg)
Cable Length	78.7 in (2000 mm)
Input Voltage	100-240 VAC
Input Frequency	50/60 Hz
Output Voltage	82.8 VDC
Charging Temperature Range	41 - 86 °F (5 - 30 °C)
Charging Time: 80% 100%	1 hour 1.5 hours

**Table 5. Noise and Vibration Emissions**

Measured Sound Power Level in dB(A)	97
Guaranteed Sound Power Level in dB(A)	100
Guaranteed Sound Pressure Level at Operator Station in dB(A)	84
Hand-Arm Vibration in m/s <sup>2</sup>	3.6

**NOTES:**

1. Products are tested for sound pressure level in accordance with European Directives 2000/14/EC and 2005/88/EC, relating to Noise Emission in the Environment by equipment for use outdoors.
2. Products are tested for hand/arm vibration (HAV) level in accordance with European Directives 2002/44/EC and EN500-4 and ISO 5349-1:2001, ISO 5349-2:2001.

# DIMENSIONS

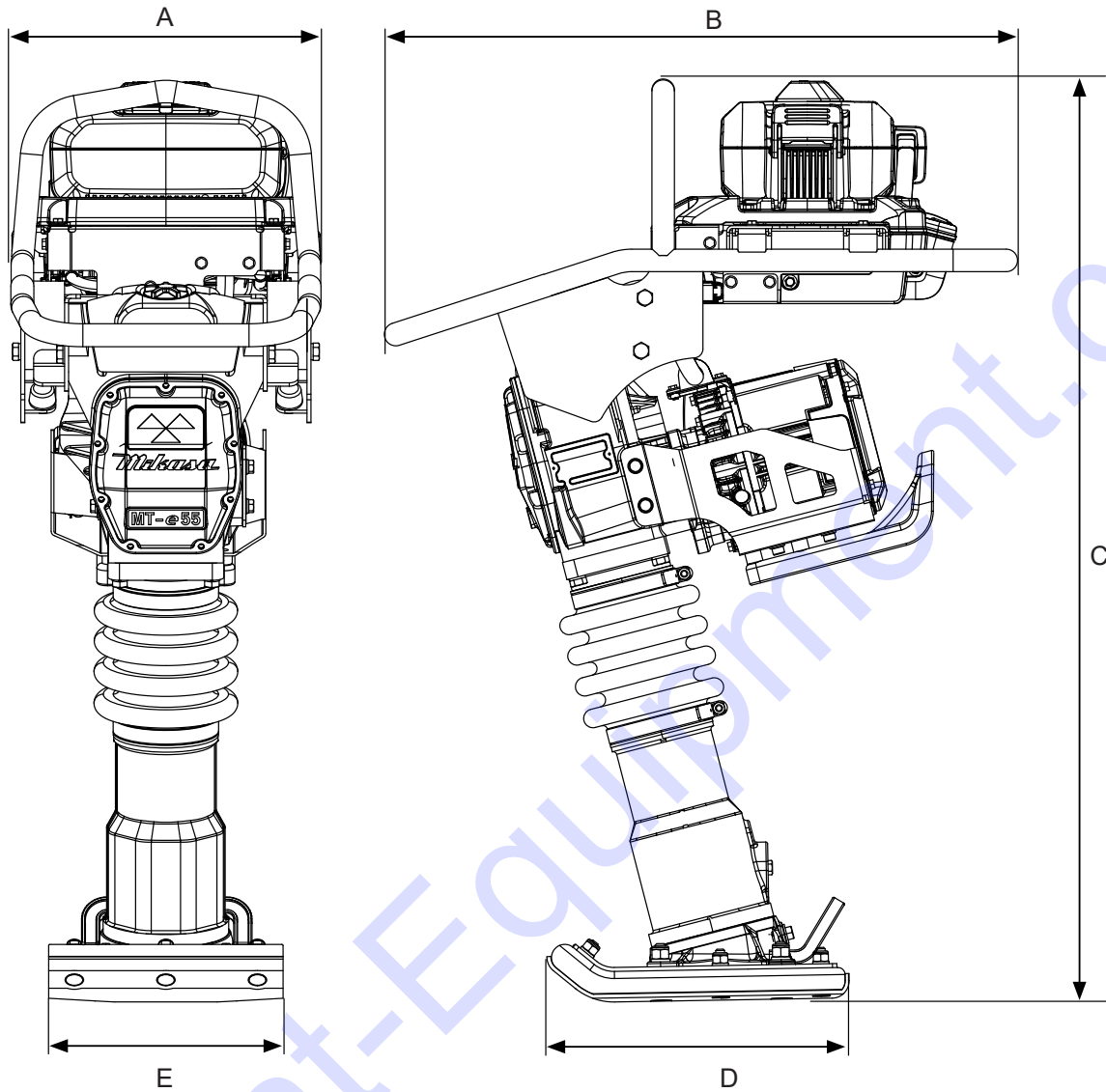

**Table 6. Dimensions**

Reference	Measurement
A	13.78 in (350 mm)
B	28.15 in (715 mm)
C	40.94 in (1040 mm)
D	13.39 in. (340 mm)
E	10.43 in. (265 mm)

The Multiquip MTe55 rammer is a powerful compacting tool capable of applying a tremendous force in consecutive impacts to a soil surface. Its applications include soil compacting for road, embankments and reservoirs as well as backfilling for gas pipelines, water pipelines and cable installation work.

The impact force of the MTe55 levels and uniformly compacts voids between soil particles to increase dry density.

Circular motion is converted to create impact force. The MTe55 tamping rammer develops a powerful compacting force at the foot of the rammer. To maintain optimum performance, proper operation and service are essential.

The MTe55 is equipped with a DC power unit. Transmission of the power takes place by increasing the DC power unit speed to engage the centrifugal clutch.

The DC power unit speed is reduced to the speed required for tamping by the reduction ratio of the pinion gear and crank gear.

Circular motion is converted to create reciprocating motion through the crank gear and connecting rod.

This reciprocating motion creates jumping motion of the foot up and down through the strong coil spring of spring cylinder.

The rammer creates strong impact force to the ground by its own weight and the jumping motion of foot. Before starting the MTe55 Tamping Rammer, identify and understand the function of the controls.

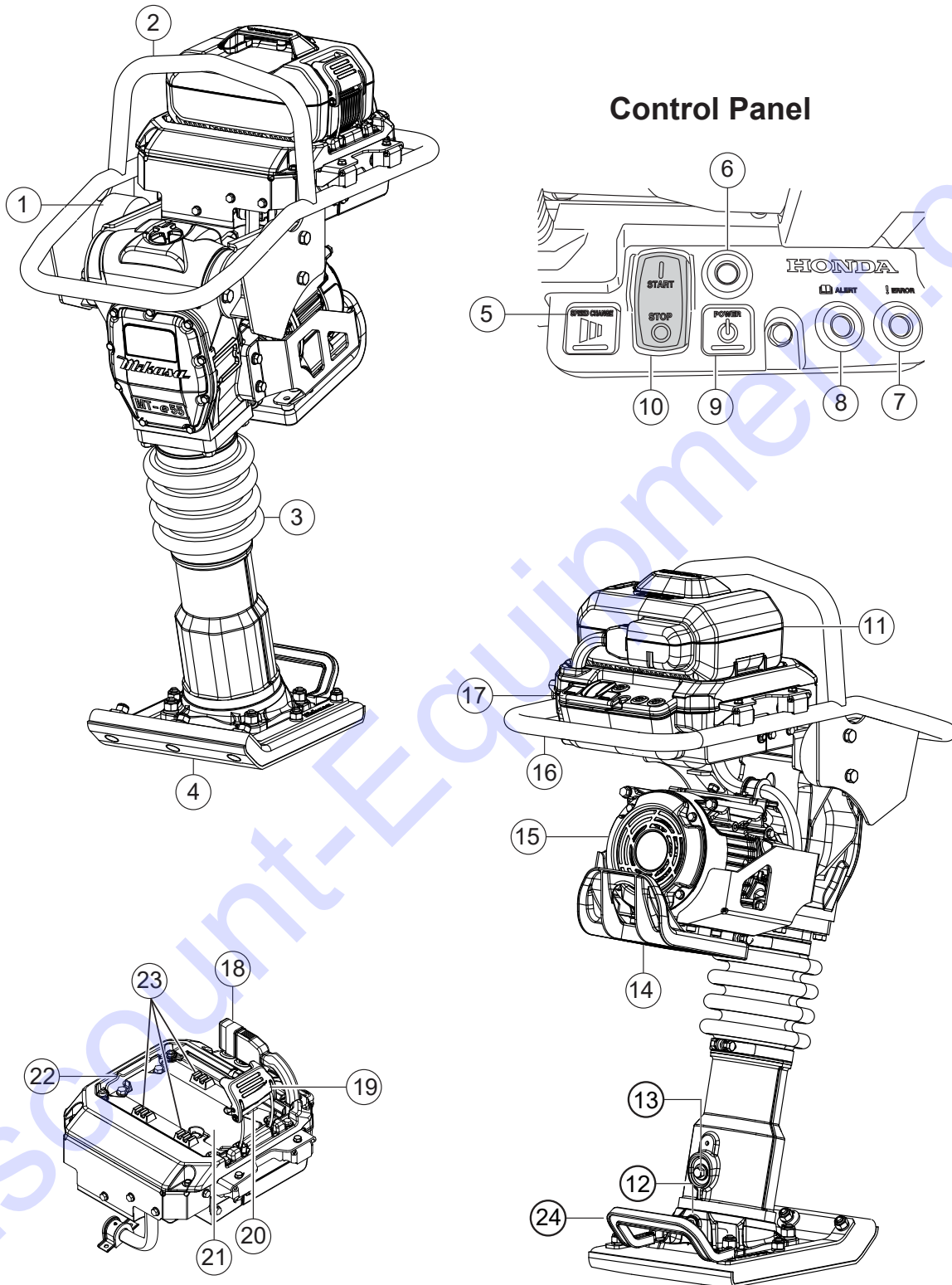

Figure 1. MTe55 Rammer

## COMPONENTS

Figure 1 shows the location of the controls and components for the MTe55 Tamping Rammer. The functions of each control is described below:

1. **Shock Absorber** — Designed to absorb or dampen the compression and rebound of the springs and suspension.
2. **Center Lifting Point** — Connection point for a lifting hook or strap when lifting with a forklift, crane or other machinery.
3. **Bellows** — Reservoir for oil bath.
4. **Foot** — Laminated wood with tempered steel plate for superior shock absorption.
5. **Speed Change Button** — Used to set the DC Power Unit speed as required.
6. **Power Indicator** — Lights green when the power button is pressed.
7. **Error Indicator** — Lights red when an error is detected.
8. **Alert Indicator** — Lights orange to indicate something is wrong with rammer.
9. **Power Button** — Used to turn power on and off.
10. **Start/Stop Button** — Used to start and stop DC Power Unit.
11. **Battery Pack** — Rechargeable Lithium Ion Battery.
12. **Drain Plug** — Open this valve to remove oil from the bellows.
13. **Oil Inlet Plug**— Used to fill rammer with oil.
14. **Motor Guard** — Protects motor.
15. **Motor** —Three-phase brushless DC Power Unit.
16. **Handle** — To operate rammer, **GRIP** handle assembly firmly on both sides.
17. **Control Panel** — contains buttons and indicators to operate rammer.
18. **Battery Connector Cap** — Protects the battery connector on the power cable.
19. **Battery Fastener Lever** — Locks the battery fastener.
20. **Battery Fastener** — Used to hook the battery pack in place.
21. **Battery Tray** — Holds the battery pack.
22. **Battery Hook** — Attaches the battery pack to the battery tray.
23. **Battery Support** — Where the battery pack sits on the battery tray.
24. **Lower Lifting Handle** — Used with rollers (item 6) to facilitate the loading onto tailgate of a truck or transport vehicle.

# TRANSPORTING AND LIFTING

Inspect the **lower lifting handle** (Figure 2) for cracks or damage. If the lifting handle is damaged in any way, replace it immediately. Ensure hardware is properly tightened before use.

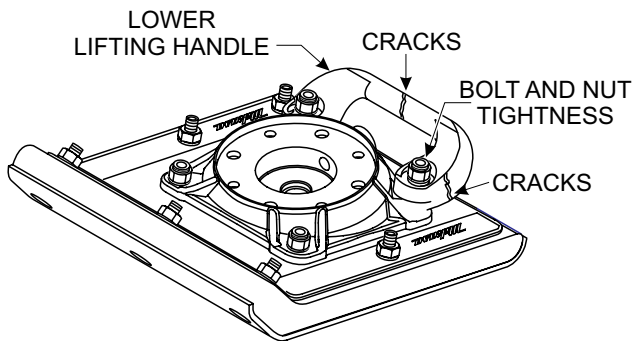

Figure 2. Lower Lifting Handle Inspection

## RAMMER LOADING (TRUCK TAILGATE)

1. Tilt rammer so that the roller makes contact with the edge of the truck tail gate as shown in Figure 3.
2. Next, grab lower lifting handle and **push** rammer forward until rammer is fully positioned onto truck bed.
3. Using straps, secure rammer to truck bed.

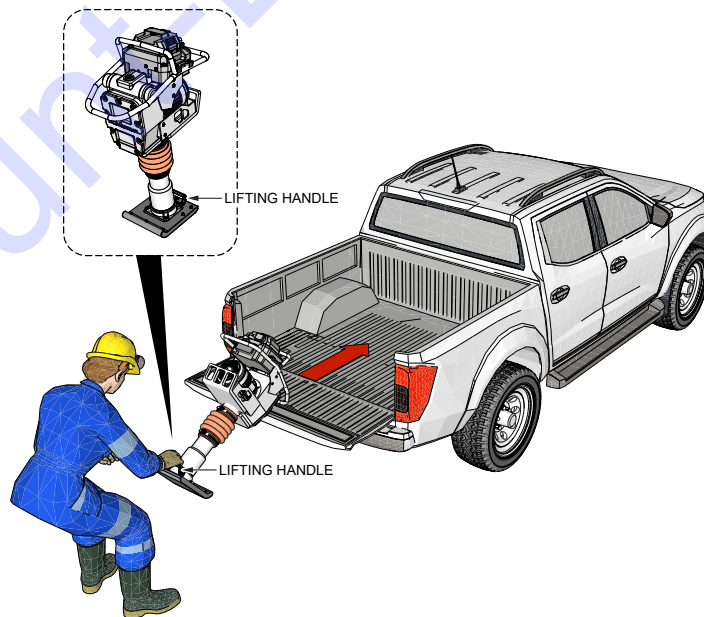

Figure 3. Loading Rammer Onto Truck Bed

## NOTICE

**DO NOT** use the lower lifting handle as a connection point when transporting or lifting with forklifts, cranes or other machinery.

## RAMMER LIFTING

1. When using a forklift or crane to lift the rammer, attach a suitable lifting strap to the **lifting handle** on the rammer as shown in Figure 4.

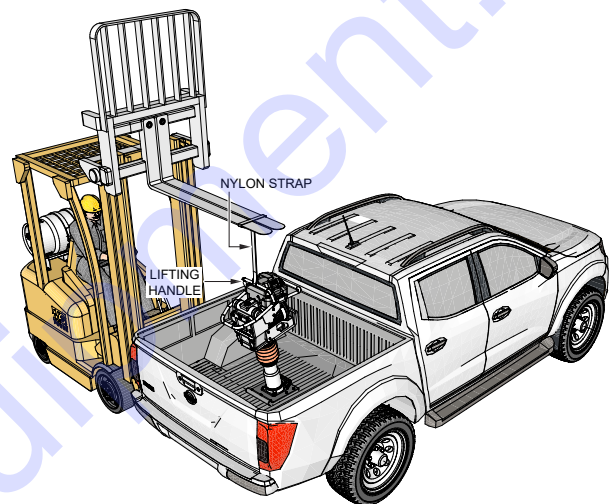

Figure 4. Rammer Lifting (Forklift/Crane)



It is extremely important that this section be read carefully before attempting to operate the rammer. **DO NOT** use your rammer until this section is thoroughly understood.

## GENERAL INSPECTION

1. Clean each parts of the machine.
2. Thoroughly remove dirt and oil from themachine.
3. Make sure that all bolts and nuts are not loose. If they are loose, retighten them to prevent any accidents.
4. Make sure that the handle and shock absorbers are not damaged. If they are damaged, replace with new ones.
5. Replace any missing or damaged safety and operation decals.

## OIL BATH

This unit uses an oil bath lubrication system. Perform the following:

1. Check the oil level at the oil inlet plug (Figure 5).

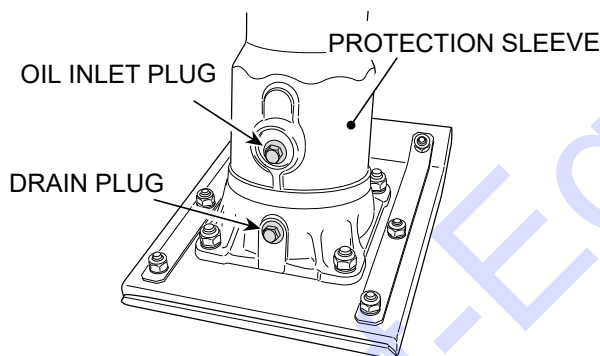

**Figure 5. Oil Inlet Plug**

2. If oil is not visible, add 10W-30 SE or higher grade motor oil (Table 7) into the oil fill plug opening (Figure 5). Fill to the edge of the oil inlet hole The bath contains approximately 0.66 qt. (0.62 liter).

**Table 7. Motor Oil Grade**

Season or Temperature	Grade of motor oil (higher than MS class)
Spring, Summer or Autumn +120° F to +15° F	SAE 30
Winter +40° F to +15° F	SAE 30
Below +15° F	SAE 10W-30

## BATTERY PACK AND BATTERY CHARGER

### NOTICE

Follow the owner's manual provided with the battery pack and battery charger for the following operations:

- Charging and Charge Level
- Cleaning
- Storage
- Disposal

### NOTICE

Follow the owner's manual provided with the DC power unit when attaching and removing the battery pack.

## Attaching the Battery Pack

1. Make sure there are no debris or dirt on the battery tray (Figure 6).

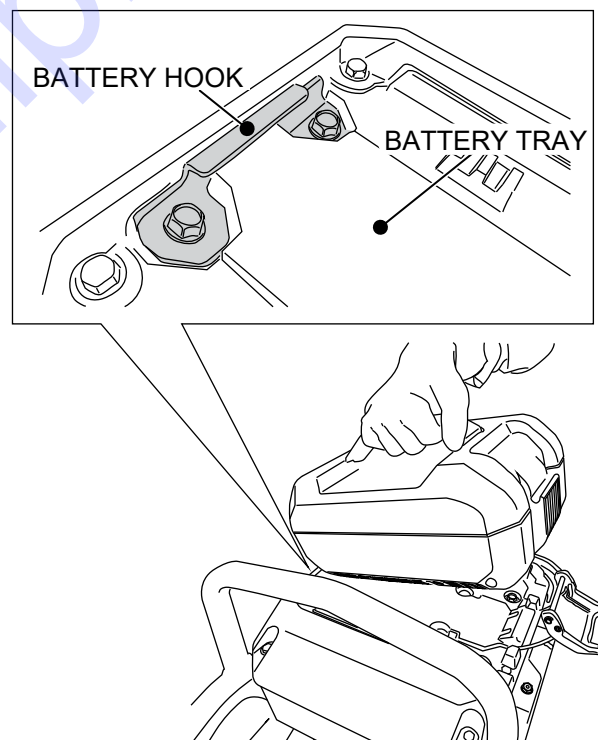

**Figure 6. Battery Tray**

2. Tilt the battery pack and insert its claw into the battery hook.
3. Push down the battery pack and hook the battery fastener to it (Figure 7).

4. Push the battery fastener (Figure 7) lever up and lock the battery pack. Be careful not to catch your fingers.

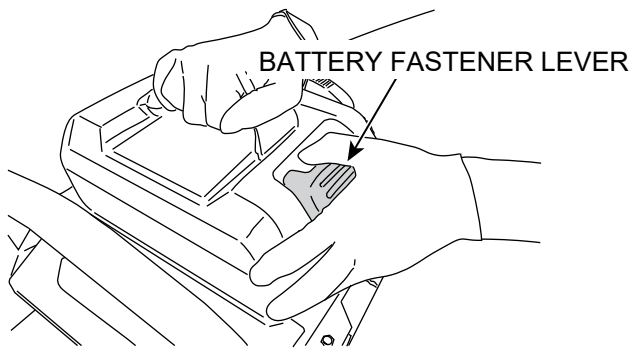

**Figure 7. Battery Fastener Lever**

5. Remove the battery connector cap from the power cable (Figure 8).

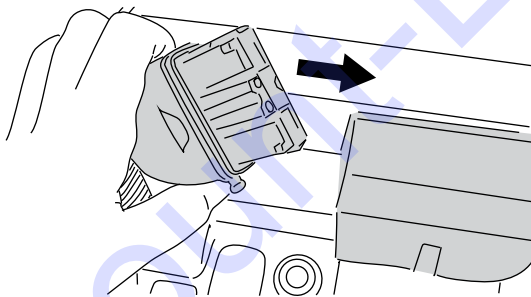
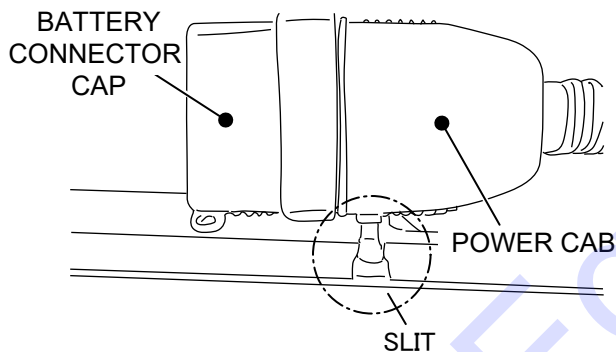

**Figure 8. Battery Connector**

6. Connect the power cable to the battery connector of the battery pack (Figure 8).
7. After attaching the battery pack, make sure the battery hook and fastener are securely attached.

## Removing the Battery Pack

1. Remove the power cable from the battery pack.
2. Pull the battery fastener down to unlock, tilt the battery pack up, and pull the battery pack claw out from the battery hook.
3. Remove the battery pack.
4. Attach the battery connector cap to the power cable.



## CAUTION

Failure to understand the operation of the rammer could result in severe damage to the unit or personal injury.

## CAUTION

Rammer should only be operated while **standing behind the machine, and holding Guide Handle firmly with both hands** (Figure 9A). **NEVER** operate rammer while holding handle/roller at the front of the machine (Figure 9B), damage to the unit could result and personal injury.

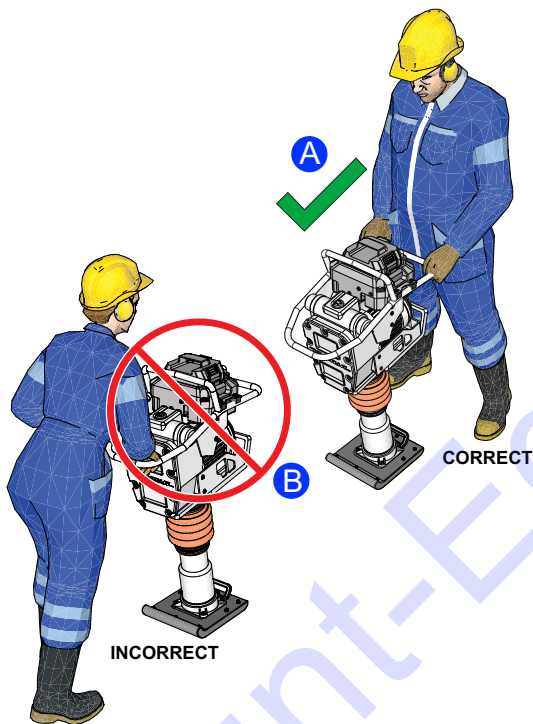

Figure 9. Rammer Operating Position

## STARTUP

Refer to Figure 10 for location of buttons and indicators on the control panel.

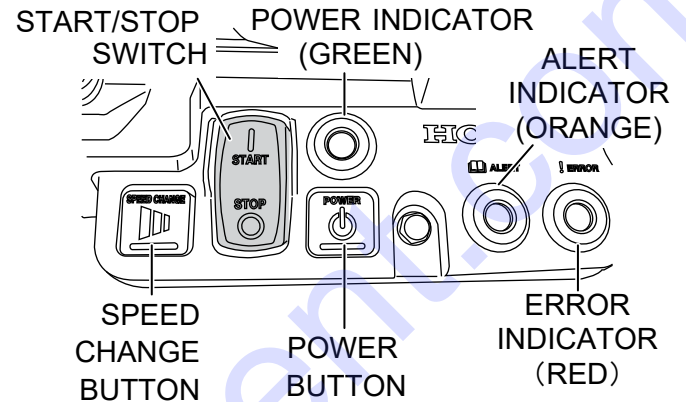

Figure 10. Control Panel

When starting the MTe55 rammer, perform the following:

1. Press STOP on the START/STOP switch.
2. Press the POWER button.
3. All the indicators should illuminate for a few seconds, and then only the POWER indicator remains illuminated.

## OPERATION

1. Hold the handle firmly.
2. Press START on the START/STOP switch to start tamping action by starting the DC Power Unit.
3. Push the SPEED CHANGE button to set the DC Power Unit speed as required. See Table 8 for speed settings.
4. The rammer is designed to advance while tamping.

Table 8. Speed Stages

Number of Pushes (Speed Change Button)	Speed
None (Start)	Rated
Once	Low
Twice	Medium
Thrice	Rated

5. For faster advance, pull back slightly on the handle so that rear of foot contacts soil first.
6. To stop the tamping action, press STOP on the START/STOP switch. The DC Power Unit stops and the POWER indicator turns off.

## NOTICE

- If the POWER button is pressed when the START/STOP switch is in the START position, the POWER indicator remains off and the ALERT indicator flashes. In this case, the DC Power Unit cannot start. Press STOP on the START/STOP switch then press the POWER button.
- It may take some time for the indicators to light after the POWER button is pressed. If the indicators do not light, press the POWER button again.
- If the DC Power Unit is not operated for about one minute after the POWER button is pressed, the POWER indicator turns off. Press the POWER button again to start the DC Power Unit.

## CAUTION

- **DO NOT** use this machine on ground that is harder than the machine can handle, or for driving pilings or tamping rock beds.
- Furthermore, use of the machine on sloping ground, such as the side of an embankment, may make the machine unstable and can cause an accident. It can also result in premature machine wear due to uneven loads on the machine.
- Only use the machine for tamping earth and sand, soil, gravel, and asphalt.
- **DO NOT** use the machine for other types of jobs.
- In cold weather, the rammer can be warmed up by pressing START and STOP on the START/STOP switch several times until the rammer operates smoothly.

## STOPPING THE DC POWER UNIT

1. Press STOP on the START/STOP switch
2. The DC Power Unit stops and the POWER indicator turns off.

## CAUTION

You can also stop the DC Power unit by pressing the POWER button, but it may take some time to stop.

## DAILY

- Thoroughly remove dirt and oil from machine.
- Make sure that all bolts and nuts are not loose. If they are loose, retighten them to avoid any accidents.
- Retighten all nuts for assembling foot.
- 

## OIL REPLACEMENT

- Remove the oil drain plug (Figure 11) on foot housing and drain the main body oil.
- Refill the main body oil from the oil inlet plug on the protection sleeve on level ground. Fill to the edge of the oil inlet hole with the recommended oil type.

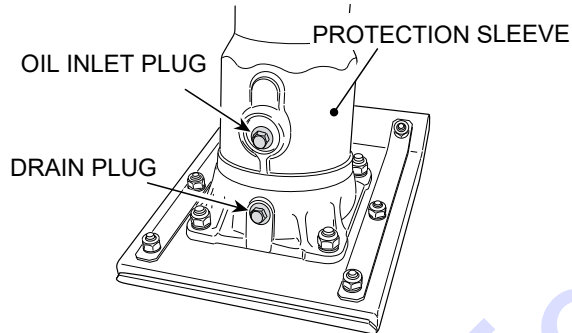

Figure 11. Oil Drain Plug

## CLEANING

Do not use a hose or pressure washer to spray water on the DC Power Unit and Battery Pack while cleaning them. Water entering the components may cause a malfunction.

## STORAGE

1. Stop the DC Power unit before storing the machine.
2. Do not move the machine until the DC Power Unit and main body have cooled down enough.
3. Remove the battery pack.
4. Avoid storage areas with high temperature and high humidity, or environments with severe temperature changes.
5. Keep away from direct sunlight and rain.
6. Put a cover on the machine to avoid exposure to dirt.

## TROUBLESHOOTING

Troubleshooting (DC Power Unit)		
Symptom	Possible Problem	Solution
DC Power Unit starts normally, but tamping stroke is not stable or it does not tamp.	Excessive main body oil?	Correct quantity of oil.
	Clutch slips?	Correct or replace.
	Spring failure?	Replace.
	Bearing failure?	Replace.

