



SPARE PARTS LIST

SURFACE PREPARATION EQUIPMENT

PG 280, 2018-02

Go to Discount-Equipment.com to order your parts



PARTS FINDER

**Search Website
by Part Number**



**Search Manual
Library For Parts
Manual & Lookup Part
Numbers – Purchase
or Request Quote**

Search Manuals

Enter your information to search for a manual or parts manual for your equipment.

* Brand:

* Model:

* Serial:

* Part Number:

SEARCH

**Can't Find Part or
Manual? Request Help
by Manufacturer,
Model & Description**

Parts Order Form

Please fill in the following information to request help finding a part or manual.

Manufacturer:

Model:

Description:

Part Number:

Quantity:

Price:

Submit

Discount-Equipment.com is your online resource for quality parts & equipment.

Florida: **561-964-4949** Outside Florida TOLL FREE: **877-690-3101**

Need parts?

Click on this link: <http://www.discount-equipment.com/category/5443-parts/> and choose one of the options to help get the right parts and equipment you are looking for. Please have the machine model and serial number available in order to help us get you the correct parts. If you don't find the part on the website or on one of the online manuals, please fill out the request form and one of our experienced staff members will get back to you with a quote for the right part that your machine needs.

We sell worldwide for the brands: Genie, Terex, JLG, MultiQuip, Mikasa, Essick, Whiteman, Mayco, Toro Stone, Diamond Products, Generac Magnum, Airman, Haulotte, Barreto, Power Blanket, Nifty Lift, Atlas Copco, Chicago Pneumatic, Allmand, Miller Curber, Skyjack, Lull, Skytrak, Tsurumi, Husquvarna Target, Stow, Wacker, Sakai, Mi-T-M, Sullair, Basic, Dynapac, MBW, Weber, Bartell, Bennar Newman, Haulotte, Ditch Runner, Menegotti, Morrison, Contec, Buddy, Crown, Edco, Wyco, Bomag, Laymor, EZ Trench, Bil-Jax, F.S. Curtis, Gehl Pavers, Heli, Honda, ICS/PowerGrit, IHI, Partner, Imer, Clipper, MMD, Koshin, Rice, CH&E, General Equipment, Amida, Coleman, NAC, Gradall, Square Shooter, Kent, Stanley, Tamco, Toku, Hatz, Kohler, Robin, Wisconsin, Northrock, Oztec, Toker TK, Rol-Air, APT, Wylie, Ingersoll Rand / Doosan, Innovatech, Con X, Ammann, Mecalac, Makinex, Smith Surface Prep, Small Line, Wanco, Yanmar

A PG 280
Motor 1-Phase

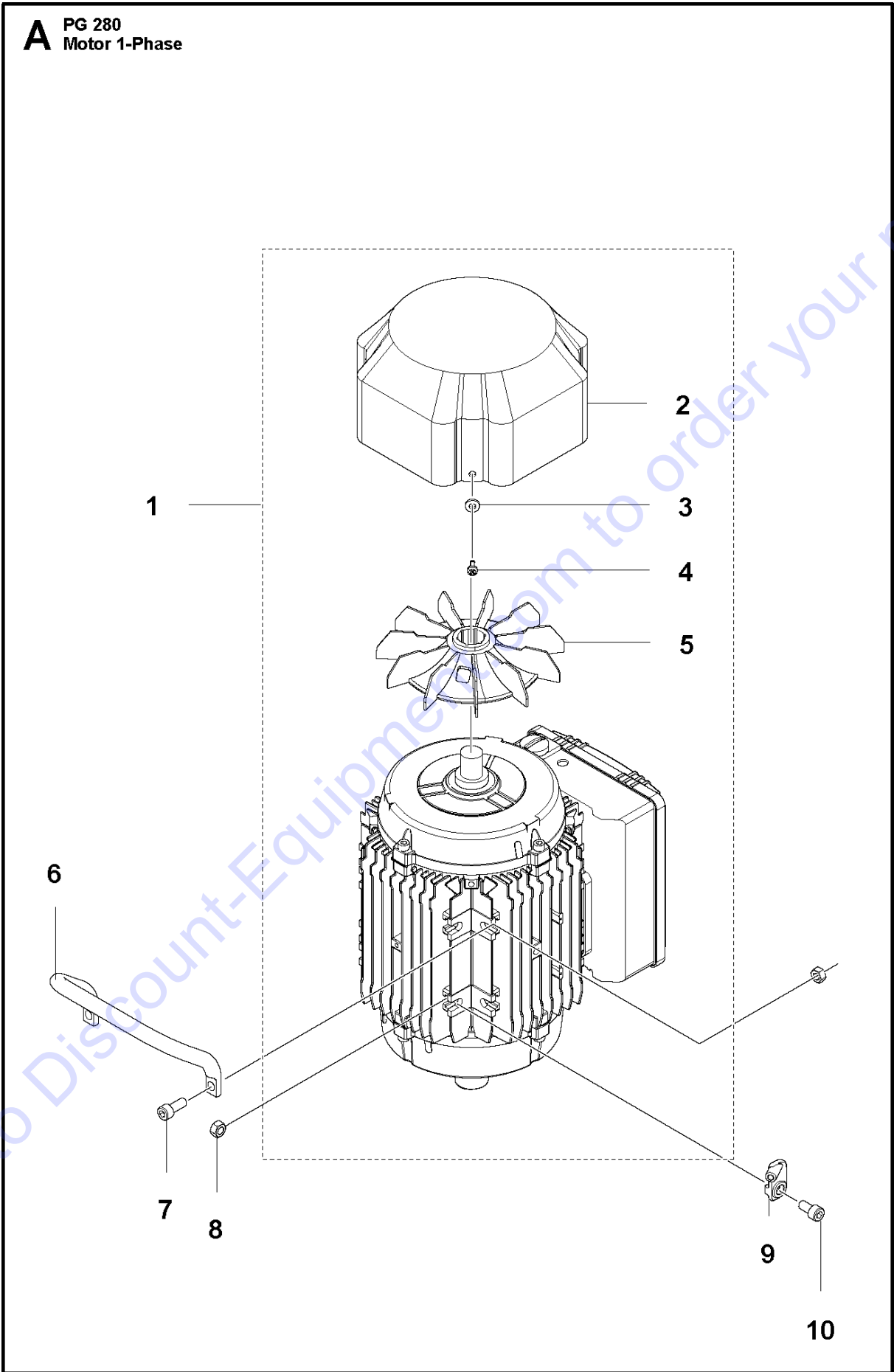

Ref	Part No	Description	Remark	QTY KIT	
1	585 30 19-01	MOTOR	220-240V, 50 Hz	1	
1	585 30 19-02	MOTOR	220-240V, 60 Hz	1	
1	594 73 61-03	MOTOR	100-120V, 50 Hz	1	
1	585 30 21-02	MOTOR	100-120V, 60 Hz	1	
2	587 17 46-01	FAN COVER		1	1
3	734 11 46-01	WASHER		4	1
4	724 13 23-01	SCREW CRPANM		4	1
5	587 17 47-01	FAN		1	1
6	585 42 33-03	HANDLE		1	
7	725 54 53-01	SCREW IHSCM		2	
8	731 23 18-01	HEXAGON NUT		4	
9	588 13 38-01	BRACKET		1	
10	725 54 51-01	SCREW IHSCM		2	

Go to Discount-Equipment.com to order your parts

B PG 280
Grinding Head

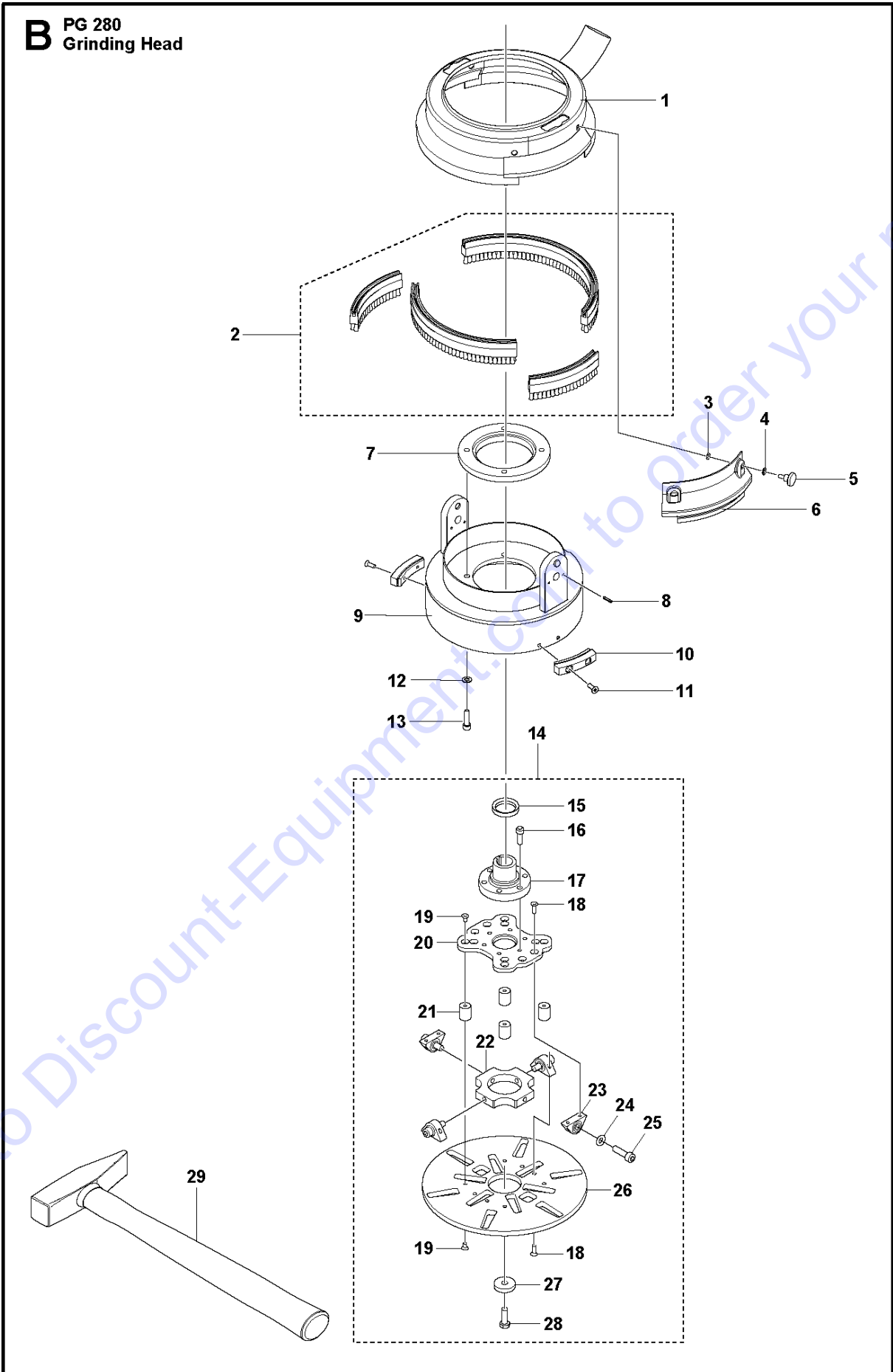

Ref	Part No	Description	Remark	QTY	KIT
1	585 13 87-01	COVER		1	
2	582 63 99-01	BRUSH KIT		1	
3	735 58 35-01	WASHER		4	
4	734 11 52-60	WASHER		4	
5	510 36 16-03	SCREW		4	
6	586 99 93-01	COVER LID		1	
7	585 52 44-02	SPACER		1	
8	721 12 59-30	GROOVED PIN		4	
9	585 12 83-01	MOUNTING PLATE		1	
9	585 12 83-02	MOUNTING PLATE	HDX variant only	1	
10	585 41 11-01	BRACKET		2	
11	725 63 69-01	SCREW IHCSFM		4	
12	734 11 63-01	WASHER		4	
13	734 11 63-01	WASHER		4	
14	597 76 88-01	GRINDING DISC		1	
15	589 92 58-01	V-RING		1	14
16	725 54 53-01	SCREW IHSCM		6	14
17	594 89 54-01	COUPLER		1	14
18	725 63 70-51	SCREW IHCSFM		8	14
19	725 63 66-51	SCREW IHCSFM		8	14
20	597 75 11-01	PLATE		1	14
21	584 81 61-01	ABSORBER		4	14
22	594 89 50-01	PLATE		1	14
23	584 81 64-01	CONNECTION		4	14
24	734 11 72-01	WASHER		4	14
25	725 54 97-01	SCREW IHSCM		4	14
26	598 50 21-01	DISC		1	14
27	510 23 51-01	WASHER		1	14
28	725 24 95-71	SCREW EHHM		1	14
29	522 03 97-01	HAMMER		1	

Go to Discount-Equipment.com to order your parts

C PG 280
Chassi

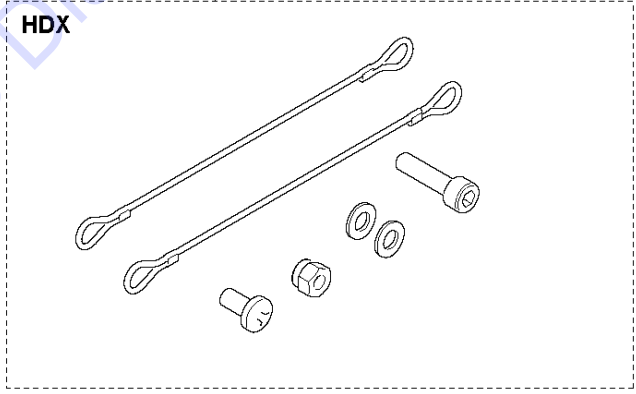
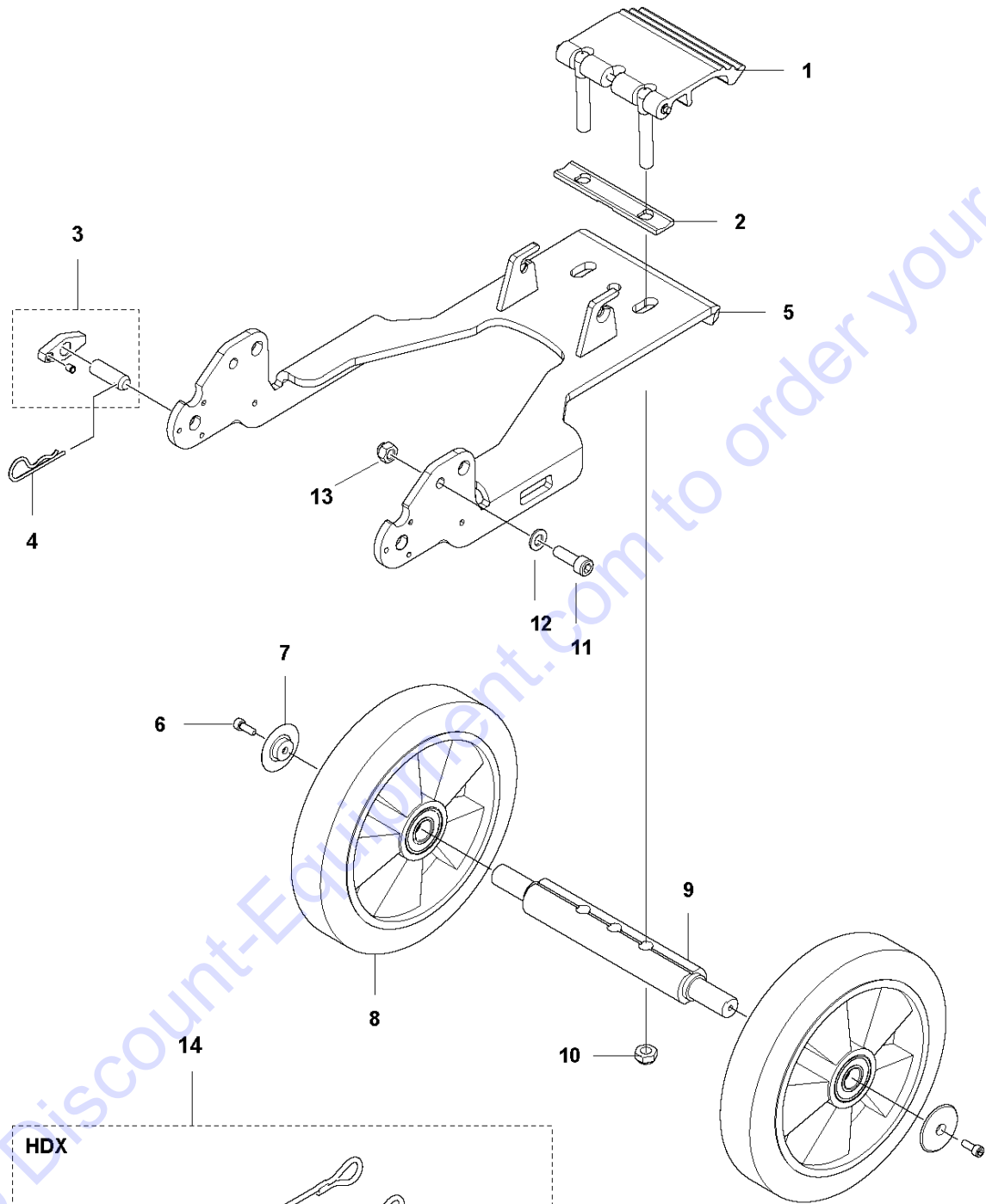

Go to Discount-Equipment.com to order your parts

Ref	Part No	Description	Remark	QTY KIT
1	587 03 29-01	PEDAL ASSY		1
2	586 92 75-01	WASHER		1
3	586 99 17-01	BOLT		2
3	586 99 17-03	BOLT	HDX variant only	2
4	721 68 02-51	SPRING COTTER		2
5	585 14 05-02	FRAME		2
6	725 53 68-51	SCREW IHSCM		2
7	501 32 12-01	WASHER		2
8	504 18 55-01	WHEEL		2
9	585 14 12-01	AXLE		1
10	732 25 22-01	HEXAGON LOCKING NUT		2
11	725 54 95-01	SCREW IHSCM		2
12	734 11 72-01	WASHER		2
13	732 25 20-01	HEXAGON LOCKING NUT		2
14	590 54 00-02	WIRE	HDX variant only	1

Go to Discount-Equipment.com to order your parts

D PG 280
Frame

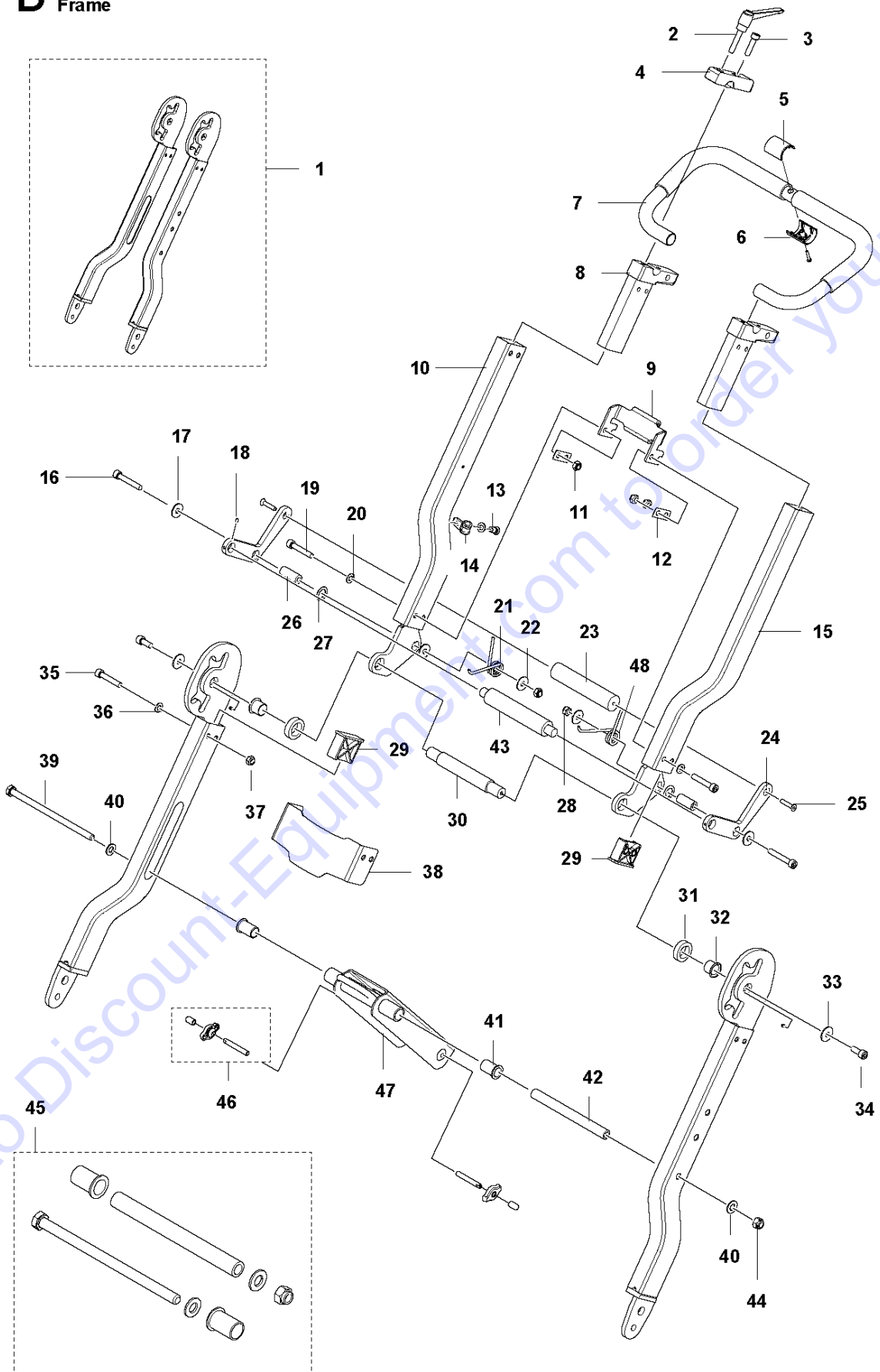

Ref	Part No	Description	Remark	QTY KIT
1	593 89 71-01	FRAME TUBE		1
2	585 12 92-01	LOCKING HANDLE		2
3	725 54 55-21	SCREW IHSCM		2
4	585 51 66-01	BRACKET		2
5	587 15 85-01	COVER		1
6	587 15 86-01	COVER		1
7	585 14 40-01	HANDLE		1
8	589 83 77-01	BRACKET		2
9	585 38 28-02	BRACKET		1
10	585 57 35-07	FORK		1
11	732 21 18-01	LOCK NUT		8
12	585 38 31-01	WASHER		2
13	725 53 68-01	SCREW IHSCM		1
14	589 66 91-01	CLIP	AUS/US/BR 230V	1
14	589 66 91-02	CLIP		1
14	589 66 91-03	CLIP	US 100-120V	1
15	585 57 35-08	FORK		1
16	725 54 60-01	SCREW IHSCM		8
17	734 11 63-01	WASHER		8
18	728 82 85-01	SCREW IHSETM		6
19	725 54 61-01	SCREW IHSCM		2
20	734 11 64-41	WASHER		4
21	585 41 73-01	SPRING		1
22	734 11 65-41	WASHER		4
23	585 13 37-02	HANDLE		1
24	585 13 33-01	PLATE		2
25	725 63 74-51	SCREW		2
26	585 38 33-02	SLEEVE		2
27	585 41 62-01	WASHER		2
28	732 21 18-01	LOCK NUT		2
29	585 13 29-01	SPACER		4
30	585 13 36-02	TUBE		1
31	585 13 35-01	SPACER		2
32	585 41 60-01	BUSH		2
33	734 11 65-41	WASHER		2
34	732 21 18-01	LOCK NUT		2
35	725 54 60-01	SCREW IHSCM		8
36	734 11 63-01	WASHER		8
37	732 25 18-01	HEXAGON LOCKING NUT		10
38	585 38 30-02	BRACKET		1
38	585 38 30-04	BRACKET	HDX variant only	1
39	590 10 50-01	BOLT		1
40	734 11 72-01	WASHER		2
41	585 12 91-01	BUSH		2
42	590 09 29-01	PIPE		1
43	585 13 38-02	ROD		1
44	732 25 20-01	HEXAGON LOCKING NUT		1
45	593 90 94-01	CROSSBAR		1
46	590 47 22-01	WING KNOB		2
47	585 14 18-02	SUPPORT		1
48	585 41 61-01	SPRING		1

Go to Disassembly.com to order your parts

E PG 280
Electrical

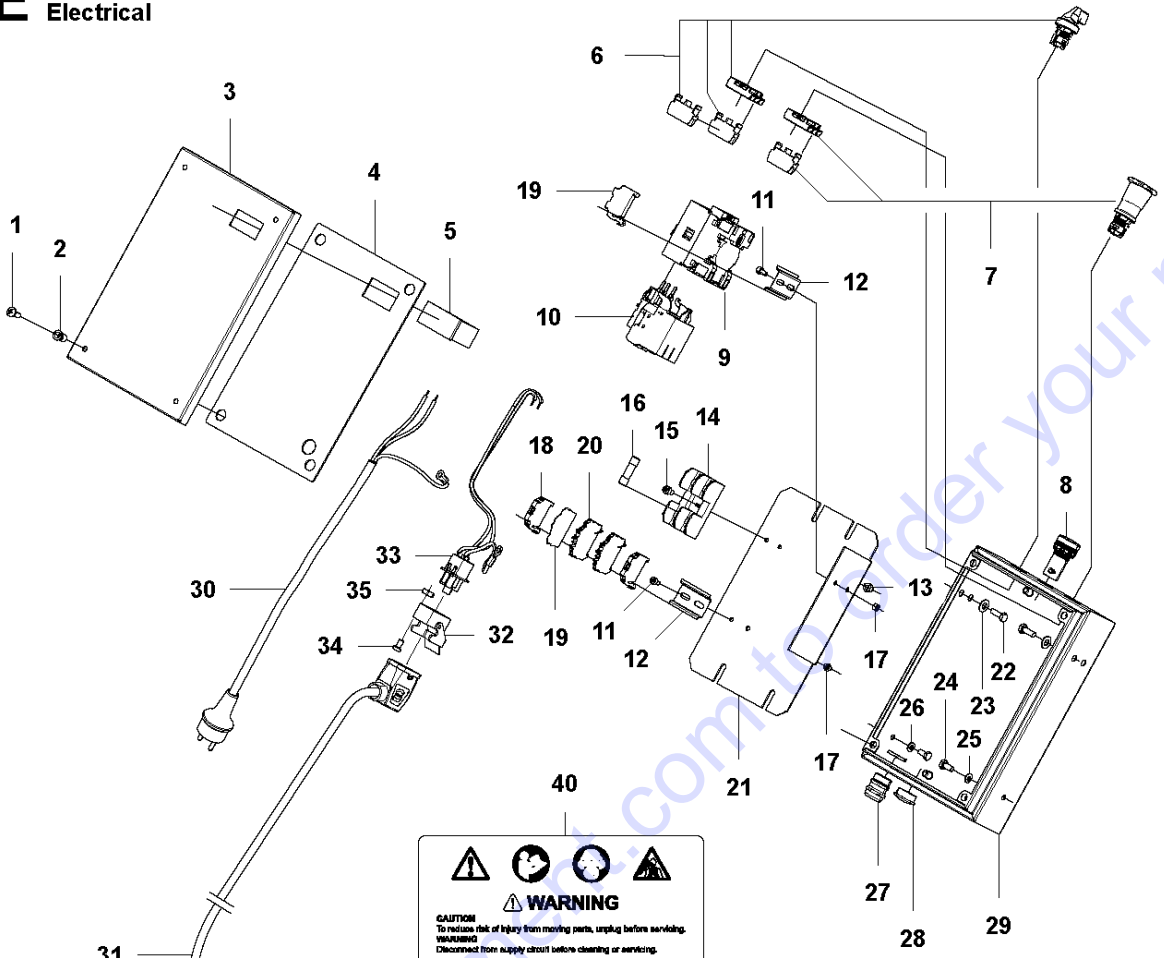

WARNING

CAUTION
To reduce risk of injury from moving parts, unplug before servicing.
Déconnecter du circuit d'alimentation avant le nettoyage ou l'entretien.

ATTENTION
Afin de réduire le risque de blessures liées aux pièces mobiles, déconnecter le matériel avant toute opération d'entretien.

AVERTISSEMENT
Déconnecter du circuit d'alimentation avant le nettoyage ou l'entretien.



Motor 1-Phase

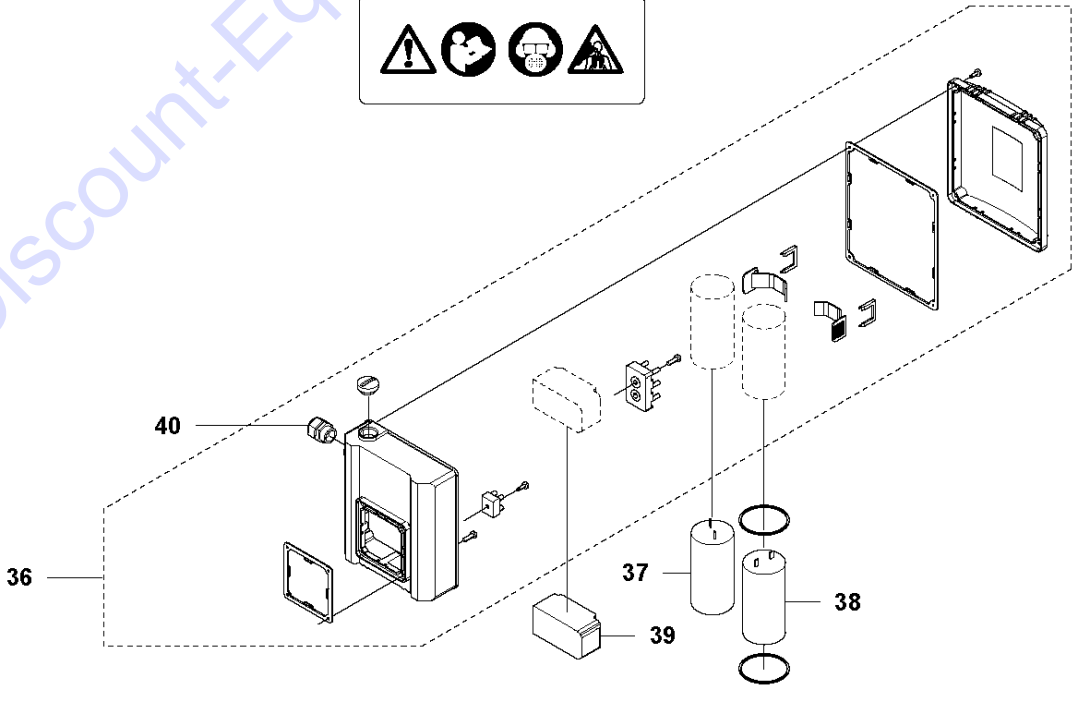

Ref	Part No	Description	Remark	QTY KIT
1	724 13 68-51	SCREW CRPANM		4
2	521 88 66-01	RIVET		4
3	586 47 43-01	LID		1
3	586 47 43-03	LID	HDX variant only	1
4	586 46 70-02	SEALING		1
5	584 29 63-01	HOUR METER		1
6	586 99 15-01	SWITCH KIT		1
7	586 99 16-01	SWITCH KIT		1
8	584 29 71-01	LAMP	230V	1
8	584 29 71-02	LAMP	110V	1
9	585 36 58-01	CONTACTOR	200-230V, 50/60Hz	1
9	585 36 58-02	CONTACTOR	100-120V, 60Hz	1
9	586 99 18-01	CONTACTOR	100-120V, 50Hz	1
10	584 29 78-01	RELAY	1 phase, 220-240V, 50Hz	1
10	580 62 35-02	PROTECTION	1 phase, 220-240V, 60Hz	1
10	580 62 35-01	PROTECTION	1 phase, 100-120V, 50Hz	1
11	725 53 25-01	SCREW IHSCM		4
12	522 74 70-01	RAIL		2
13	731 23 16-01	HEXAGON NUT		1
14	525 88 26-01	FUSE HOLDER		1
15	725 53 64-55	SCREW IHSCM		1
16	525 63 81-01	FUSE		2
17	732 25 14-01	HEXAGON LOCKING NUT		4
18	585 36 61-05	TERMINAL BLOCK		3
19	585 36 61-03	TERMINAL BLOCK		1
19	585 36 61-07	TERMINAL BLOCK	US 1ph 100-120V	1
20	585 61 35-01	TERMINAL BLOCK		2
20	585 36 61-01	TERMINAL BLOCK	US 1ph 100-120V	2
21	590 07 58-01	MOUNTING PLATE		1
22	725 24 51-71	SCREW EHHM		4
23	734 11 63-01	WASHER		4
24	725 23 66-51	HEXAGONAL SCREW M6X12		2
25	734 11 52-01	WASHER		1
26	735 21 53-01	LOCKWASHER		4
27	575 48 98-01	GROMMET		1
27	587 10 12-01	GROMMET	US 1ph 100-120V	1
28	586 58 69-01	PLUG		1
28	587 10 12-01	GROMMET	US variant only	1
29	582 50 69-03	ELECTRONIC BOX		1
29	582 50 69-04	ELECTRONIC BOX	HDX variant only	1
30	586 23 68-03	CABLE		1
30	586 23 68-02	CABLE	AUS	1
30	586 23 68-12	CABLE	US 120V	1
30	586 23 68-13	CABLE	US 240V	1
30	586 23 68-08	CABLE	BR	1
31	585 63 81-08	CABLE	UK and JP	1
31	585 63 81-10	CABLE	US/CAN 220-240V	1
31	585 63 81-11	CABLE	US/CAN 100-120V	1
32	585 36 66-05	CONNECTOR		1
33	590 50 35-01	CONNECTOR		1
34	725 52 24-01	SCREW		2
35	732 25 10-01	HEXAGON LOCKING NUT		2
36	587 17 39-01	ELECTRONIC BOX	1-ph	1
36	587 17 39-02	ELECTRONIC BOX	3-ph	1
37	587 17 45-01	CAPACITOR	208-230V, 50/60Hz	1
37	587 17 45-02	CAPACITOR	110V, 50Hz	1
38	587 17 44-01	CAPACITOR	230V, 50Hz	1
38	587 17 44-02	CAPACITOR	208-230V, 60Hz	1
38	587 17 44-03	CAPACITOR	110V, 50/60Hz	1
39	587 17 43-01	SWITCH	230V, 50Hz	1
39	587 17 43-02	SWITCH	208-230V, 60Hz	1
39	587 17 43-03	SWITCH	110V, 50/60Hz	1
40	590 51 83-01	DECAL	US/CAN only	1
40	590 51 84-01	DECAL	ROW	1

PARTS FINDER

**Search Website
by Part Number**



**Search Manual
Library For Parts
Manual & Lookup Part
Numbers – Purchase
or Request Quote**

Search Manuals

Enter your information to help us find the right parts manual for your machine.

* Brand:

* Model:

* Serial:

* Part Number:

SEARCH

**Can't Find Part or
Manual? Request Help
by Manufacturer,
Model & Description**

Parts Order Form

Please fill in the following information to help us find the right part for your machine.

Manufacturer:	<input type="text"/>
Model:	<input type="text"/>
Description:	<input type="text"/>
Part Number:	<input type="text"/>
Quantity:	<input type="text"/>
Notes:	<input type="text"/>

Submit

Discount-Equipment.com is your online resource for quality parts & equipment.

Florida: **561-964-4949** Outside Florida TOLL FREE: **877-690-3101**

Need parts?

Click on this link: <http://www.discount-equipment.com/category/5443-parts/> and choose one of the options to help get the right parts and equipment you are looking for. Please have the machine model and serial number available in order to help us get you the correct parts. If you don't find the part on the website or on one of the online manuals, please fill out the request form and one of our experienced staff members will get back to you with a quote for the right part that your machine needs.

We sell worldwide for the brands: Genie, Terex, JLG, MultiQuip, Mikasa, Essick, Whiteman, Mayco, Toro Stone, Diamond Products, Generac Magnum, Airman, Haulotte, Barreto, Power Blanket, Nifty Lift, Atlas Copco, Chicago Pneumatic, Allmand, Miller Curber, Skyjack, Lull, Skytrak, Tsurumi, Husquvarna Target, Stow, Wacker, Sakai, Mi-T-M, Sullair, Basic, Dynapac, MBW, Weber, Bartell, Bennar Newman, Haulotte, Ditch Runner, Menegotti, Morrison, Contec, Buddy, Crown, Edco, Wyco, Bomag, Laymor, EZ Trench, Bil-Jax, F.S. Curtis, Gehl Pavers, Heli, Honda, ICS/PowerGrit, IHI, Partner, Imer, Clipper, MMD, Koshin, Rice, CH&E, General Equipment, Amida, Coleman, NAC, Gradall, Square Shooter, Kent, Stanley, Tamco, Toku, Hatz, Kohler, Robin, Wisconsin, Northrock, Oztec, Toker TK, Rol-Air, APT, Wylie, Ingersoll Rand / Doosan, Innovatech, Con X, Ammann, Mecalac, Makinex, Smith Surface Prep, Small Line, Wanco, Yanmar