

PARTS MANUAL



Mikasa **SERIES**
MODEL MTe55
TAMPING RAMMER
(HONDA GXE2.0S 2.1 HP ELECTRIC MOTOR)

Revision #1 (11/17/21)

To find the latest revision of this publication or associated operation manual, visit our website at: www.Discount-Equipment.com



THIS MANUAL MUST ACCOMPANY THE EQUIPMENT AT ALL TIMES.

MTe55 Tamping Rammer

Explanation Of Code In Remarks Column.....	4
Suggested Spare Parts	5

Component Drawings

Nameplate And Decals.....	6-7
Crankcase and Motor Assembly.....	8-11
Handle Assembly.....	12-13
Battery Charger Assembly.....	14-15
Spring and Guide Cylinder Assembly.....	16-17
Foot Assembly	18-19

NOTICE

Specifications and part numbers are subject to change without notice.

TO PURCHASE THIS PRODUCT PLEASE CONTACT US



**Equipment Financing and
Extended Warranties Available**



**Discount-Equipment.com is your online resource for
commercial and industrial quality parts and equipment sales.**

561-964-4949

visit us on line @ www.discount-equipment.com

Select an option below to find your Equipment

Search by Manufacturer

Search by Product Type

Request a Quote

We sell worldwide for the brands: Genie, Terex, JLG, MultiQuip, Mikasa, Essick, Whiteman, Mayco, Toro Stone, Diamond Products, Generac Magnum, Airman, Haulotte, Barreto, Power Blanket, Nifty Lift, Atlas Copco, Chicago Pneumatic, Allmand, Miller Curber, Skyjack, Lull, Skytrak, Tsurumi, Husquvarna Target, Stow, Wacker, Sakai, Mi-T-M, Sullair, Basic, Dynapac, MBW, Weber, Bartell, Bennar Newman, Haulotte, Ditch Runner, Menegotti, Morrison, Contec, Buddy, Crown, Edco, Wyco, Bomag, Laymor, EZ Trench, Bil-Jax, F.S. Curtis, Gehl Pavers, Heli, Honda, ICS/PowerGrit, IHI, Partner, Imer, Clipper, MMD, Koshin, Rice, CH&E, General Equipment, Amida, Coleman, NAC, Gradall, Square Shooter, Kent, Stanley, Tamco, Toku, Hatz, Kohler, Robin, Wisconsin, Northrock, Oztec, Toker TK, Rol-Air, APT, Wylie, Ingersoll Rand / Doosan, Innovatech, Con X, Ammann, Mecalac, Makinex, Smith Surface Prep, Small Line, Wanco, Yanmar

EXPLANATION OF CODE IN REMARKS COLUMN

The following section explains the different symbols and remarks used in the Parts section of this manual. Use the help numbers found on the back page of the manual if there are any questions.

NOTICE

The contents and part numbers listed in the parts section are subject to change **without notice**. Multiquip does not guarantee the availability of the parts listed.

SAMPLE PARTS LIST

NO.	PART NO.	PART NAME	QTY.	REMARKS
1	12345	BOLT	1	INCLUDES ITEMS W/%
2%		WASHER, 1/4 IN.		NOT SOLD SEPARATELY
2%	12347	WASHER, 3/8 IN. ...	1	MQ-45T ONLY
3	12348	HOSE	A/R	MAKE LOCALLY
4	12349	BEARING	1	S/N 2345B AND ABOVE

NO. Column

Unique Symbols — All items with same unique symbol (@, #, +, %, or >) in the number column belong to the same assembly or kit, which is indicated by a note in the “Remarks” column.

Duplicate Item Numbers — Duplicate numbers indicate multiple part numbers, which are in effect for the same general item, such as different size saw blade guards in use or a part that has been updated on newer versions of the same machine.

NOTICE

When ordering a part that has more than one item number listed, check the remarks column for help in determining the proper part to order.

PART NO. Column

Numbers Used — Part numbers can be indicated by a number, a blank entry, or TBD.

TBD (To Be Determined) is generally used to show a part that has not been assigned a formal part number at the time of publication.

A blank entry generally indicates that the item is not sold separately or is not sold by Multiquip. Other entries will be clarified in the “Remarks” Column.

QTY. Column

Numbers Used — Item quantity can be indicated by a number, a blank entry, or A/R.

A/R (As Required) is generally used for hoses or other parts that are sold in bulk and cut to length.

A blank entry generally indicates that the item is not sold separately. Other entries will be clarified in the “Remarks” Column.

REMARKS Column

Some of the most common notes found in the “Remarks” Column are listed below. Other additional notes needed to describe the item can also be shown.

Assembly/Kit — All items on the parts list with the same unique symbol will be included when this item is purchased.

Indicated by:

“INCLUDES ITEMS W/(unique symbol)”

Serial Number Break — Used to list an effective serial number range where a particular part is used.

Indicated by:

“S/N XXXXX AND BELOW”

“S/N XXXX AND ABOVE”

“S/N XXXX TO S/N XXX”

Specific Model Number Use — Indicates that the part is used only with the specific model number or model number variant listed. It can also be used to show a part is NOT used on a specific model or model number variant.

Indicated by:

“XXXXX ONLY”

“NOT USED ON XXXX”

“Make/Obtain Locally” — Indicates that the part can be purchased at any hardware shop or made out of available items. Examples include battery cables, shims, and certain washers and nuts.

“Not Sold Separately” — Indicates that an item cannot be purchased as a separate item and is either part of an assembly/kit that can be purchased, or is not available for sale through Multiquip.

SUGGESTED SPARE PARTS

MTe55 TAMPING RAMMER WITH HONDA GXE2.0S ELECTRIC MOTOR

1 to 3 units

Qty.	P/N	Description
2.....	351316870.....	BELLOWS BAND
1.....	353332870.....	BELLOWS (OR)
1.....	361463840.....	CLUTCH ASSEMBLY
3.....	362456610.....	ELEMENT, BREATHER

NOTICE

Part numbers on this Suggested Spare Parts list may supersede/replace the part numbers shown in the following parts lists.

NAMEPLATE AND DECALS ASSY.

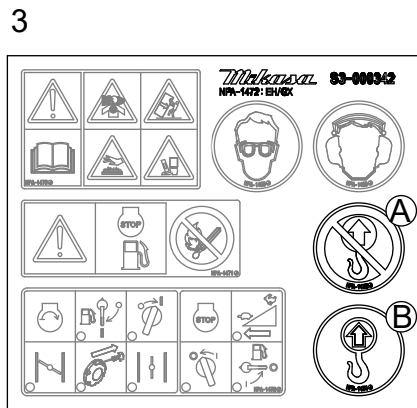
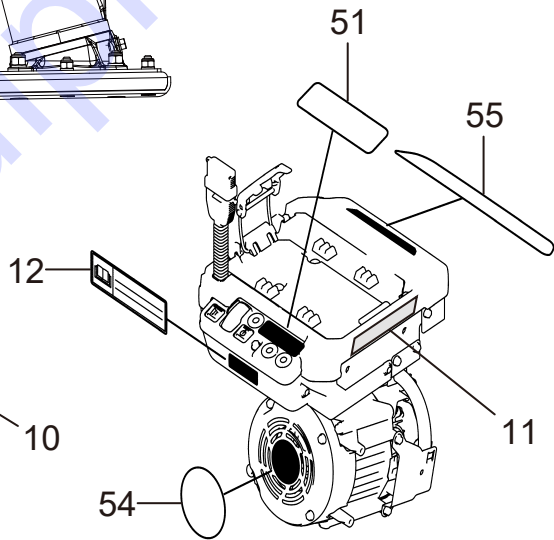
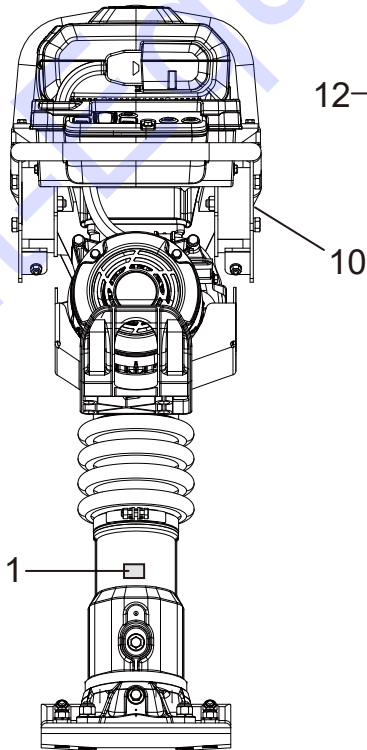
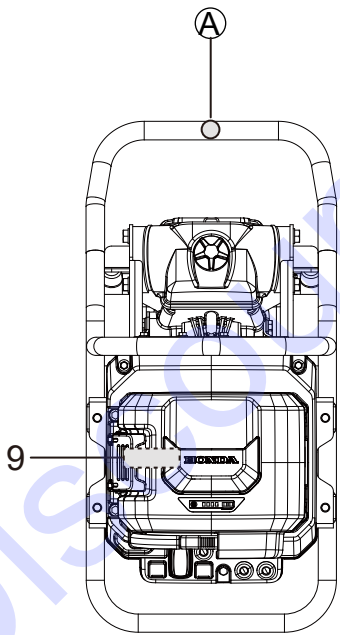
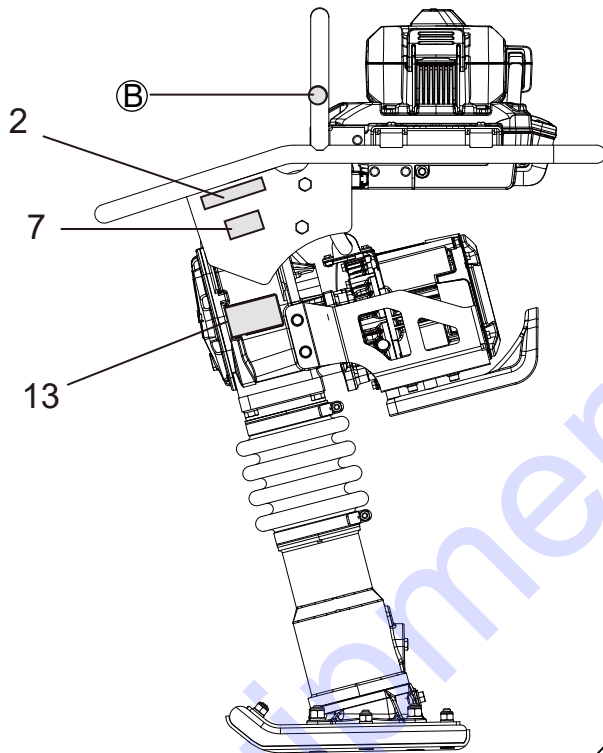
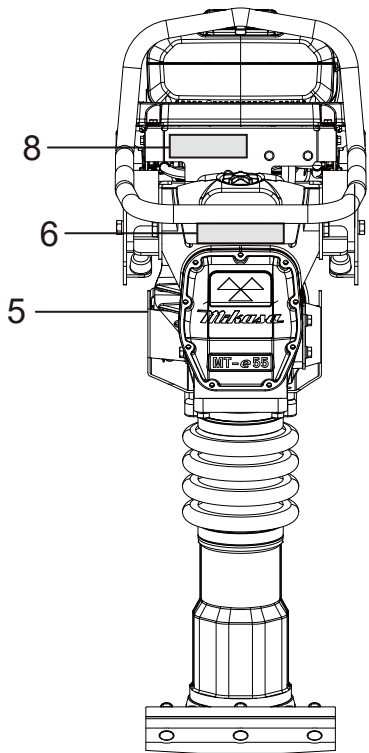

NAMEPLATE AND DECALS ASSY.

<u>NO.</u>	<u>PART NO.</u>	<u>PART NAME</u>	<u>QTY.</u>	<u>REMARKS</u>
1	920201950	DECAL, OIL SAE 10W-30	1.....	NPA-195
2	920210870	DECAL, CAUTION/CONBI PL4	1.....	NPA-1087
3	920900100	DECAL, SET/MT, MTX/EXP, EU	1.....	NPA-1473, 74
5	920222240	DECAL, PROPOSITION 65	1.....	NPA-2224
6	920224690	DECAL, EARTH SMART	1.....	NPA-2469
7	920224540	DECAL, CAUTION/COMBI/E55	1.....	NPA-2454
8	920224550	DECAL, CAUTION HOOK/E55	1.....	NPA-2455
9	920224560	DECAL, FASTENER STORAGE/E55	1.....	NPA-2456
10	920224750	DECAL, MQ, 3 YEARS WARRANTY	1.....	NPA-2475
11	920224760	DECAL, CAUTION RAINY AND WASH	1.....	NPA-2476
12	875168A0620	MARK, OPER CAUTION (E).....	1.....	HONDA
13	920224660	PLATE, SERIAL NO./E55/MQ.....	1.....	NPA-2466
51	872378A0800	MARK, LED IND	1.....	HONDA
54	875218A0800	MARK, EMBLEM	1.....	HONDA
55	875238A0800	MARK, ELECTRIC PW	1.....	HONDA

CRANKCASE AND MOTOR ASSY.

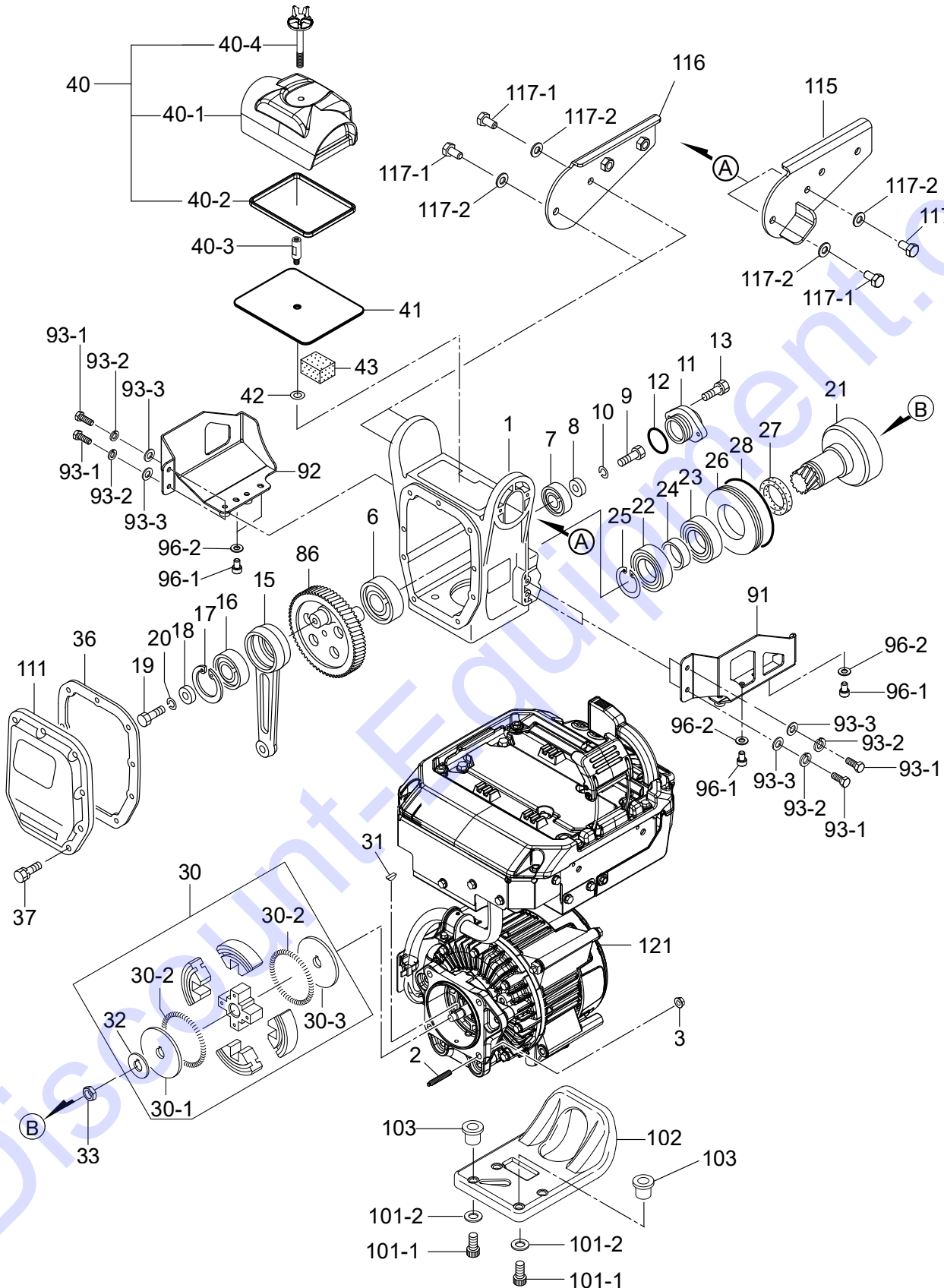

CRANKCASE AND MOTOR ASSY.

<u>NO.</u>	<u>PART NO.</u>	<u>PART NAME</u>	<u>QTY.</u>	<u>REMARKS</u>
1	362116510	CRANK CASE	1	
2	959409790	SOCKET HEAD SCREW, 8X50	4	
3	022910300	FLANGE NUT, M8	4	
6	040006305	BEARING	1	
7	042506203	BEARING.....	1	REPLACES P/N 040006203
8	952401450	WASHER, 8.5X22X3	1	
9	011208025	BOLT, 8X25.....	1	REPLACES P/N 001220825
10	030208200	LOCK WASHER, M8	1	
11	362455660	BEARING COVER	1	
12	050100350	O-RING	1	
13	002200620	BOLT W/ LOCK WASHER, 6X20	2	
15	303010060	CONNECTING ROD	1	
16	040006304	BEARING	1	
17	080100520	STOP RING	1	
18	952400130	WASHER	1	
19	011208025	BOLT, 8X25.....	1	REPLACES P/N 001220825
20	030208200	LOCK WASHER, M8	1	
21	377357370	PINION DRUM	1	
22	040006007	BEARING	1	
23	041006007	BEARING	1	
24	351437750	SPACER	1	
25	080200350	STOP RING	1	
26	351421900	SPACER, CLUTCH DRUM	1	
27	060404010	OIL SEAL	1	
28	050300900	O-RING	1	
30	361463840	CLUTCH ASSEMBLY.....	1	INCLUDES ITEMS W/#
30-1#	943060020	CLUTCH GUIDE, B	1	
30-2#	943030021	CLUTCH SPRING	2	
30-3#	943060100	CLUTCH GUIDE, A	1	
31	0053204201	WOODRUFF KEY	1	
32#	301010210	LOCK WASHER, CLUTCH	1	
33	94002120000S	NUT, M12	1	
36	362341610	PACKING, FRONT COVER	1	
37	002200620	BOLT W/ LOCK WASHER, 6X20	9	
40	377220560	ACCESSORY CASE ASSEMBLY.....	1	INCLUDES ITEMS W/\$
40-1\$	377010010	ACCESSORY CASE	1	
40-2\$	362030020	PACKING, AIR CLEANER	1	
40-3	374010070	CLEANER BOLT	1	
40-4\$	374010110	GRIP BOLT COMPLETE	1	
41	377474170	BREATHER COVER	1	
42	0401450080	FLAT WASHER, M8.....	1	REPLACES P/N 031108160
43	362456610	ELEMENT, BREATHER	1	

CRANKCASE AND MOTOR ASSY. (CONT'D.)

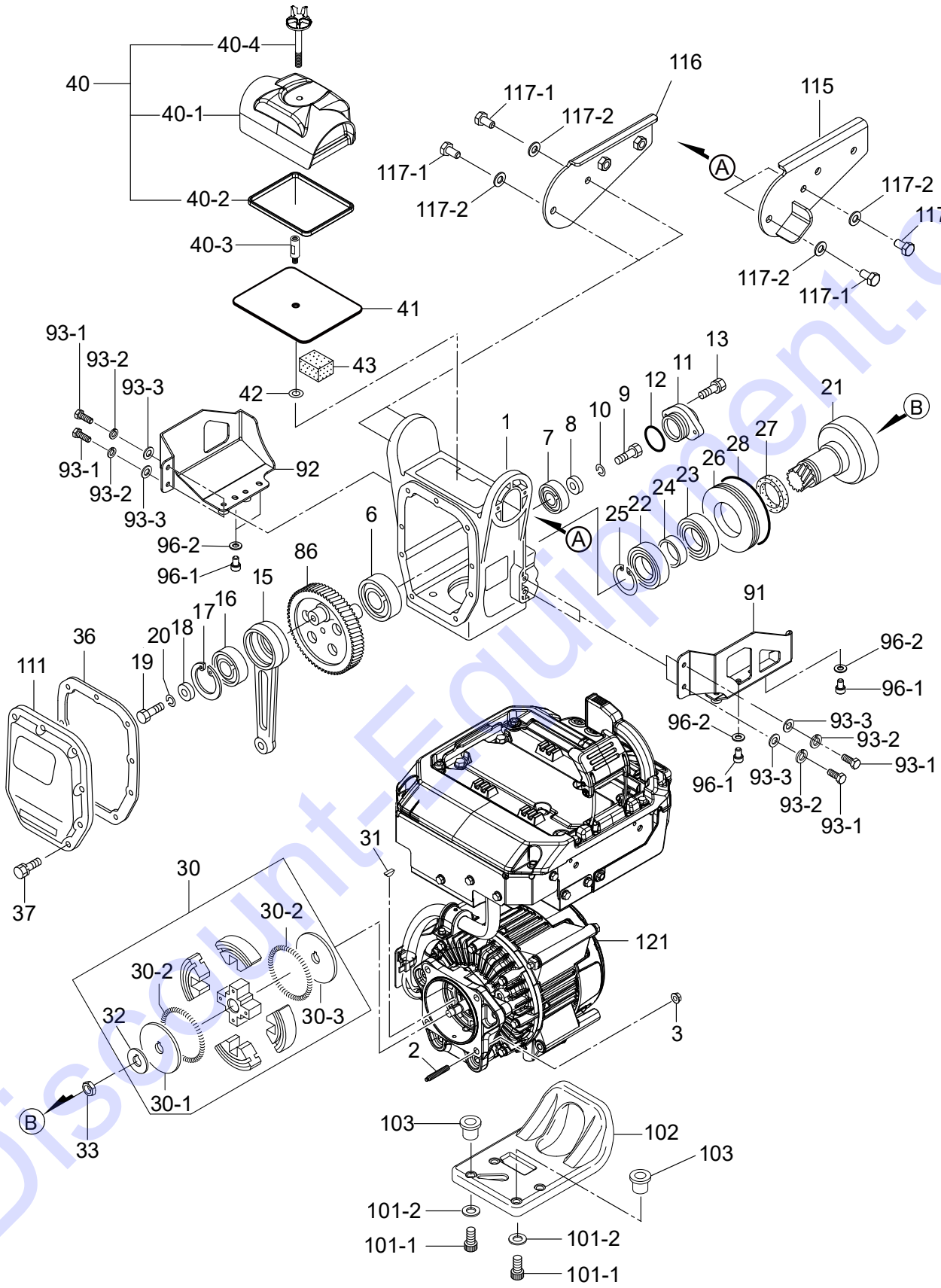

CRANKCASE AND MOTOR ASSY. (CONT'D.)

<u>NO.</u>	<u>PART NO.</u>	<u>PART NAME</u>	<u>QTY.</u>	<u>REMARKS</u>
86	377357360	CRANK GEAR	1	
91	377357800	MOTOR GUARD (L)	1	
92	377357810	MOTOR GUARD (R)	1	
93-1	001220820	BOLT, 8X20	4	
93-2	0401450080	FLAT WASHER, M8	4	REPLACES P/N 031108160
93-3	030208200	LOCK WASHER, M8	4	
96-1	014208020	SOCKET HEAD BOLT, 8X20	4	REPLACES P/N 001520820
96-2	033910220	WASHER, 8.4X15.5X1.6	4	
101-1	014208020	SOCKET HEAD BOLT, 8X20	4	REPLACES P/N 001520820
101-2	033910220	WASHER, 8.4X15.5X1.6	4	
102	374910030	GUARD, RECOIL STARTER	1	
103	366461050	COLLAR, GUARD	4	
111	377010030	FRONT COVER	1	
115	377357820	ABSORBER BRACKET (L)	1	
116	377357830	ABSORBER BRACKET (R)	1	
117-1	012210020	BOLT, 10X20	4	REPLACES P/N 001221020
117-2	030210250	LOCK WASHER, M10	4	
121	912711601	MOTOR ASSEMBLY (DC POWER UNIT)	1	

HANDLE ASSY.

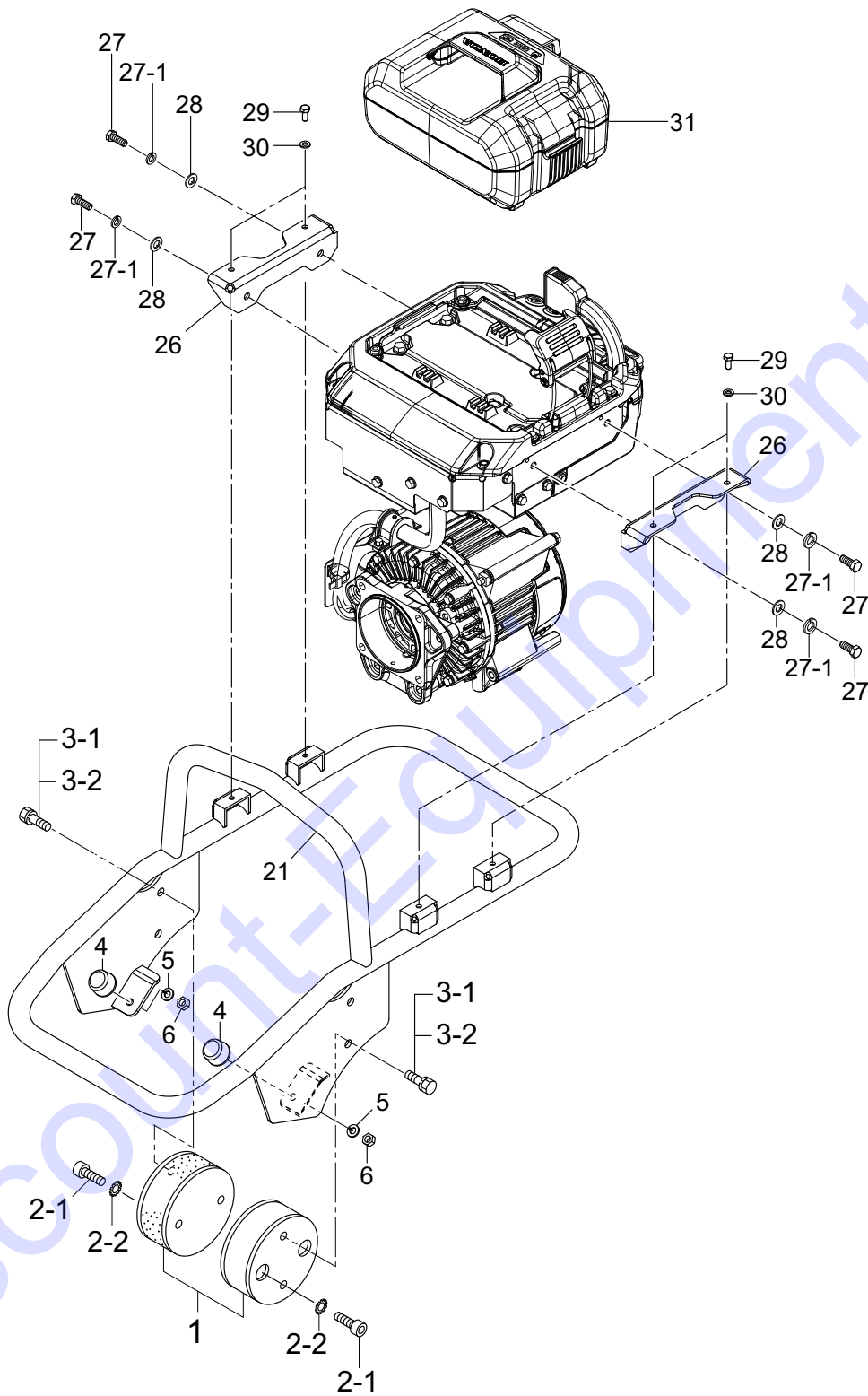

HANDLE ASSY.

<u>NO.</u>	<u>PART NO.</u>	<u>PART NAME</u>	<u>QTY.</u>	<u>REMARKS</u>
1	351325590	SHOCK ABSORBER	2	
2-1	014210020	SOCKET HEAD BOLT, 10X20	4	REPLACES P/N 001521020
2-2	033121009	TOOTHED LOCK WASHER, B M10	4	
3-1	012210020	BOLT, 10X20	4	REPLACES P/N 001221020
3-2	030210250	LOCK WASHER, M10	4	
4	939010270	STOPPER RUBBER	2	
5	030208200	LOCK WASHER, M8	2	
6	020308060	NUT, M8	2	REPLACES P/N 020308060
21	377123120	HANDLE	1	
26	377357840	PDU STAY	2	
27	001220820	BOLT, 8X20	4	
27-1	030208200	LOCK WASHER, M8	4	
28	0401450080	FLAT WASHER, M8	4	REPLACES P/N 031108160
29	0105050616	BOLT, 6X15	4	REPLACES P/N 001220615
30	952404470	FLAT WASHER, M6	4	REPLACES P/N 031106100
31	MCB7210	BATTERY PACK, LITHIUM-ION 72V 10AH	1	

BATTERY CHARGER ASSY.

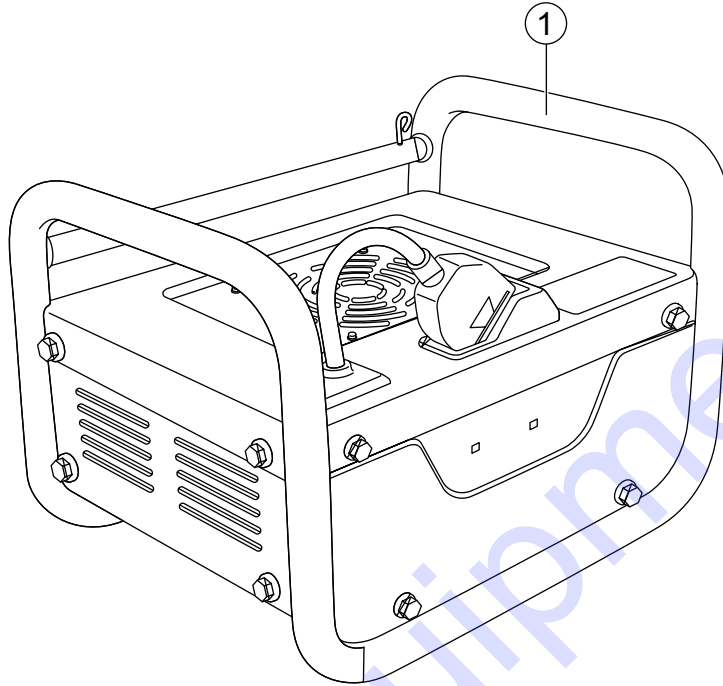

BATTERY CHARGER ASSY.

<u>NO.</u>	<u>PART NO.</u>	<u>PART NAME</u>	<u>QTY.</u>	<u>REMARKS</u>
1	MCB0190	BATTERY CHARGER	1	

Discount-Equipment.com

SPRING AND GUIDE CYLINDER ASSY.

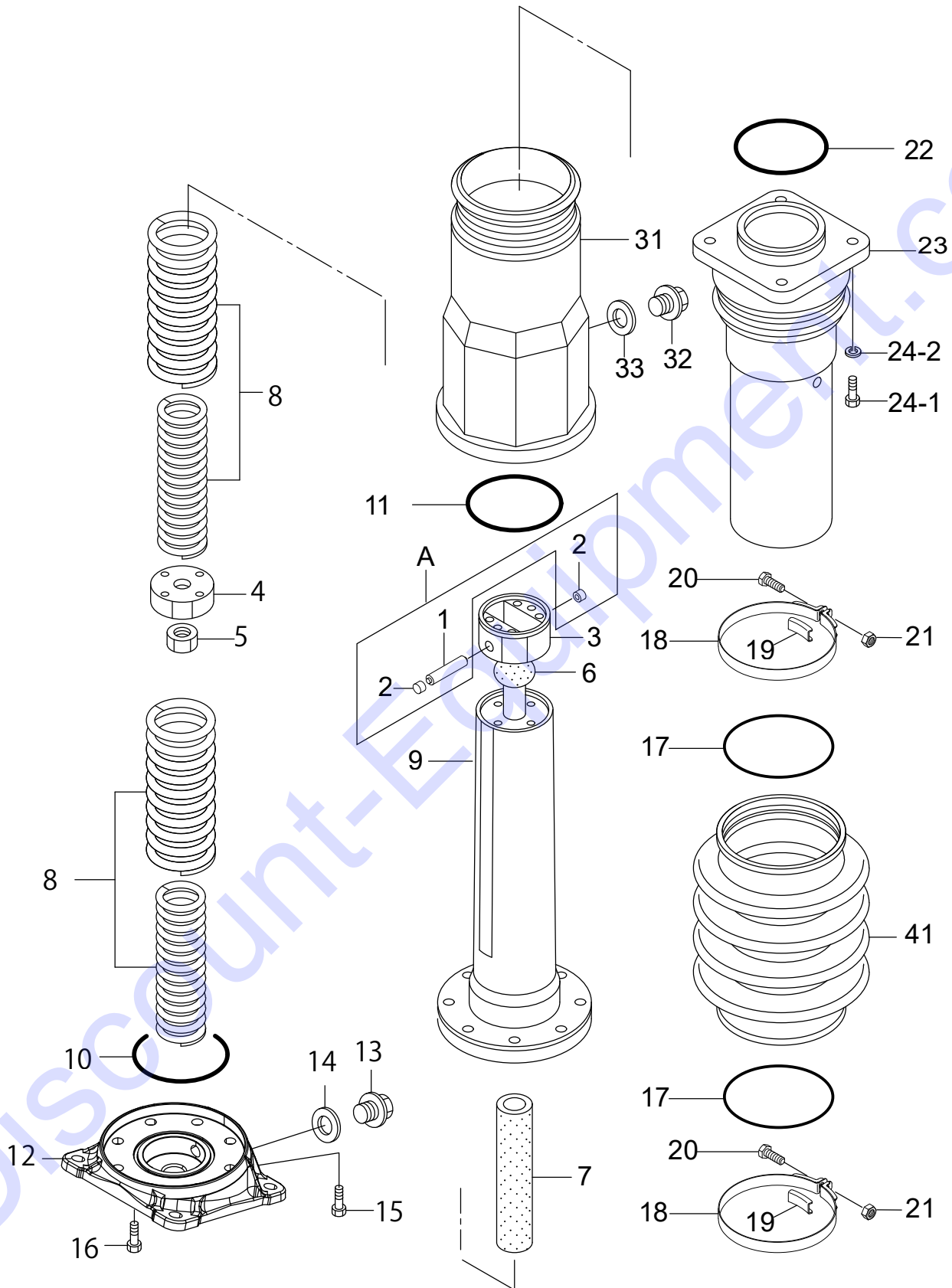

SPRING AND GUIDE CYLINDER ASSY.

<u>NO.</u>	<u>PART NO.</u>	<u>PART NAME</u>	<u>QTY.</u>	<u>REMARKS</u>
A	362910200	PISTON PIN ASSEMBLY	1.....	INCLUDES ITEMS W/%
1%	362464120	PISTON PIN	1	
2%	368459920	PLUG, PISTON PIN	2	
3	362350020	PISTON ROD	1	
4	362455680	PISTON END	1	
5	020116130	NUT M16	1	
6	351434201	STOPPER, UPPER	1	
7	351434212	STOPPER, LOWER	1	
8	377473760	MAIN SPRING	2	
9	362341640	SPRING CYLINDER	1	
10	050100750	O-RING	1	
11	EM915027	O-RING	1.....	REPLACES P/N 050930850
12	377220420	FOOT PLATE, 14.5	1	
13	953405270	PLUG, 1/4X14 13L	1	
14	953405260	PACKING, 1/4 (CU)	1	
15	014210020	SOCKET HEAD BOLT, 10X20	4.....	REPLACES P/N 001521020
16	014210035	SOCKET HEAD BOLT, 10X35	4.....	REPLACES P/N 001521035
17	050100950	O-RING	2	
18	351316870	BELLOWS BAND	2	
19	351433250	BAND GUIDE, BELLOWS	2	
20	011208035	BOLT, 8X35	2.....	REPLACES P/N 001220835
21	020108060	NUT, M8	2.....	REPLACES P/N 020308060
22	050100800	O-RING	1	
23	351209590	GUIDE CYLINDER	1	
24-1	012210040	BOLT, 10X40	4.....	REPLACES P/N 001221040
24-2	030210250	LOCK WASHER, M10	4	
31	351109010	PROTECTION SLEEVE	1	
32	953405270	PLUG, 1/4X14 13L	1	
33	953405260	PACKING, 1/4 (CU)	1	
41	353332870	BELLOWS (OR)	1	

FOOT ASSY.

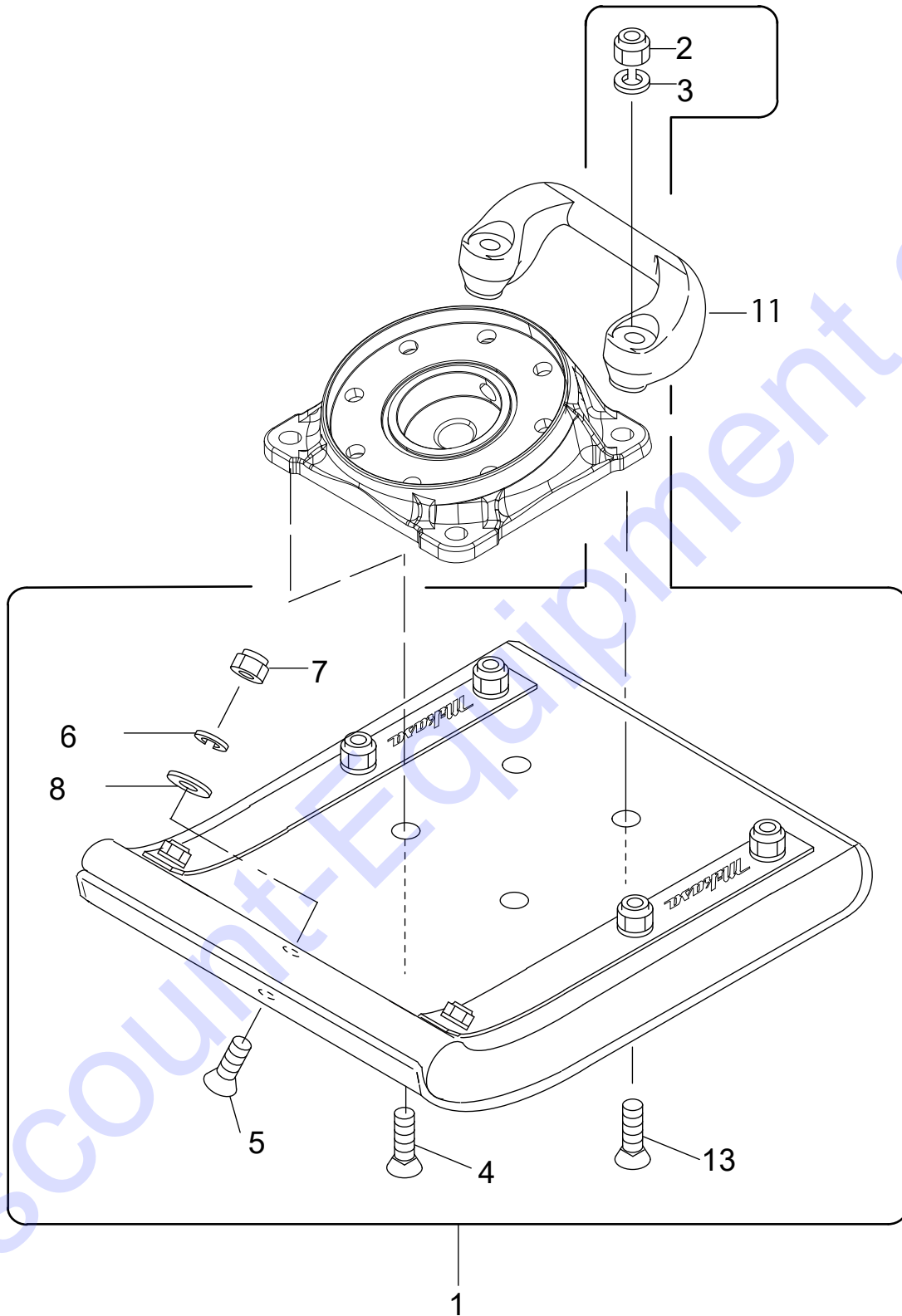

FOOT ASSY.

<u>NO.</u>	<u>PART NO.</u>	<u>PART NAME</u>	<u>QTY.</u>	<u>REMARKS</u>
1	362910150	FOOT ASSEMBLY	1.....	INCLUDES ITEMS W/\$
2\$	021112140	NYLON NUT, M12.....	4.....	REPLACES P/N 022711214
3\$	030212300	LOCK WASHER, M12	4	
4\$	009110034	BOLT, SQUARE NECK, 12X65	2	
5\$	009110036	BOLT, SQUARE NECK, 10X55	7	
6\$	030210250	LOCK WASHER, M10	7	
7\$	021110120	NYLON NUT, M10.....	7.....	REPLACES P/N 022711012
8\$	368460370	WASHER, 11X34X3.2	1	
11	363343390	GRIP HANDLE BAR	1	
13\$	009110035	BOLT, SQUARE NECK, 12X95	2	

PARTS MANUAL

HERE'S HOW TO GET HELP

PLEASE HAVE THE MODEL AND SERIAL
NUMBER ON-HAND WHEN CALLING

UNITED STATES

Multiquip Inc.

(310) 537- 3700
6141 Katella Avenue Suite 200
Cypress, CA 90630
E-MAIL: mq@multiquip.com
WEBSITE: www.multiquip.com

CANADA

Multiquip

(450) 625-2244
4110 Industriel Boul.
Laval, Quebec, Canada H7L 6V3
E-MAIL: infocanada@multiquip.com

UNITED KINGDOM

Multiquip (UK) Limited Head Office

0161 339 2223
Unit 2, Northpoint Industrial Estate,
Globe Lane,
Dukinfield, Cheshire SK16 4UJ
E-MAIL: sales@multiquip.co.uk

© COPYRIGHT 2021, MULTIQUIP INC.

Multiquip Inc, the MQ logo and the Mikasa logo are registered trademarks of Multiquip Inc. and may not be used, reproduced, or altered without written permission. All other trademarks are the property of their respective owners and used with permission.

This manual MUST accompany the equipment at all times. This manual is considered a permanent part of the equipment and should remain with the unit if resold.

The information and specifications included in this publication were in effect at the time of approval for printing. Illustrations, descriptions, references and technical data contained in this manual are for guidance only and may not be considered as binding. Multiquip Inc. reserves the right to discontinue or change specifications, design or the information published in this publication at any time without notice and without incurring any obligations.

Your Local Dealer is:

