



SPARE PARTS LIST

POWER CUTTERS

K1270, K1270 Rail, 2016-07

Go to Discount-Equipment.com to order your parts



PARTS FINDER

**Search Website
by Part Number**



**Search Manual
Library For Parts
Manual & Lookup Part
Numbers – Purchase
or Request Quote**

Search Manuals

Enter your information to help us find the right parts manual for your machine.

* Brand:

* Model:

* Serial:

* Part Number:

SEARCH

**Can't Find Part or
Manual? Request Help
by Manufacturer,
Model & Description**

Parts Order Form

Please fill in the following information to help us find the right part for your machine.

Manufacturer:	<input type="text"/>
Model:	<input type="text"/>
Description:	<input type="text"/>
Part Number:	<input type="text"/>
Quantity:	<input type="text"/>
Notes:	<input type="text"/>

Submit

Discount-Equipment.com is your online resource for quality parts & equipment.

Florida: **561-964-4949** Outside Florida TOLL FREE: **877-690-3101**

Need parts?

Click on this link: <http://www.discount-equipment.com/category/5443-parts/> and choose one of the options to help get the right parts and equipment you are looking for. Please have the machine model and serial number available in order to help us get you the correct parts. If you don't find the part on the website or on one of the online manuals, please fill out the request form and one of our experienced staff members will get back to you with a quote for the right part that your machine needs.

We sell worldwide for the brands: Genie, Terex, JLG, MultiQuip, Mikasa, Essick, Whiteman, Mayco, Toro Stone, Diamond Products, Generac Magnum, Airman, Haulotte, Barreto, Power Blanket, Nifty Lift, Atlas Copco, Chicago Pneumatic, Allmand, Miller Curber, Skyjack, Lull, Skytrak, Tsurumi, Husquvarna Target, Stow, Wacker, Sakai, Mi-T-M, Sullair, Basic, Dynapac, MBW, Weber, Bartell, Bennar Newman, Haulotte, Ditch Runner, Menegotti, Morrison, Contec, Buddy, Crown, Edco, Wyco, Bomag, Laymor, EZ Trench, Bil-Jax, F.S. Curtis, Gehl Pavers, Heli, Honda, ICS/PowerGrit, IHI, Partner, Imer, Clipper, MMD, Koshin, Rice, CH&E, General Equipment, Amida, Coleman, NAC, Gradall, Square Shooter, Kent, Stanley, Tamco, Toku, Hatz, Kohler, Robin, Wisconsin, Northrock, Oztec, Toker TK, Rol-Air, APT, Wylie, Ingersoll Rand / Doosan, Innovatech, Con X, Ammann, Mecalac, Makinex, Smith Surface Prep, Small Line, Wanco, Yanmar

K K1270

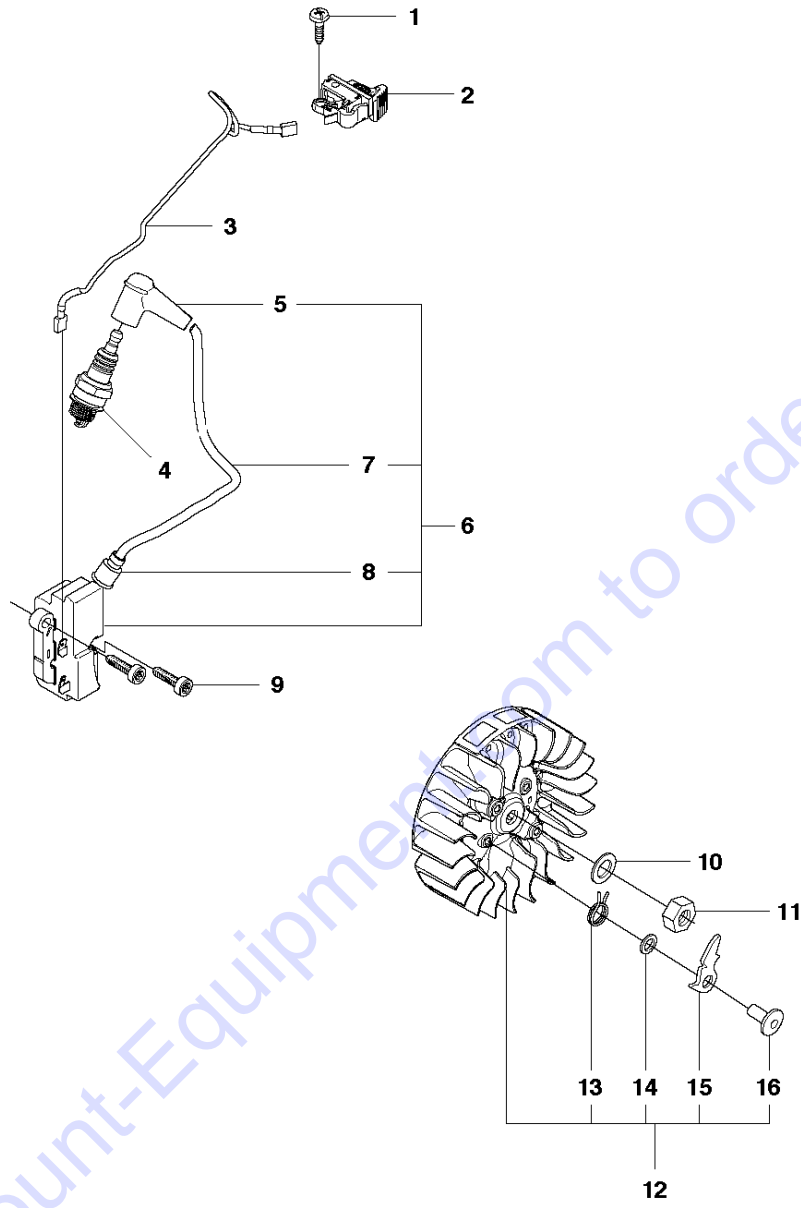

Go to Discount-Equipment.com to order your parts

IGNITION SYSTEM

K1270, K1270 Rail, 2016-07

Ref	Part No	Description	Remark	QTY	KIT
1	525 88 74-03	SCREW CITXPANT		1	
2	506 31 86-04	STOP SWITCH		1	
3	501 83 98-03	CABLE		1	
4	503 23 51-11	SPARK PLUG	RCJ 6Y	1	
5	501 48 54-02	SPARK PLUG CAP		1	
6	580 38 05-03	IGNITION MODULE	Incl. 7 - 8	1	
7	506 38 78-34	IGNITION CABLE		1	6
8	505 27 75-16	ISOLERHATT		1	6
9	503 21 53-20	SCREW ITXSCM		2	
10	735 11 73-50	SPRING WASHER		1	
11	503 22 10-11	HEXAGON NUT		1	
12	587 24 88-01	FLYWHEEL ASSY	Incl. 13 - 16	1	
13	501 63 48-01	SPRING		2	12
14	503 23 00-42	WASHER		2	12
15	501 67 32-03	PAWL		2	12
16	501 81 99-01	SCREW		2	12

Go to Discount-Equipment.com to order your parts

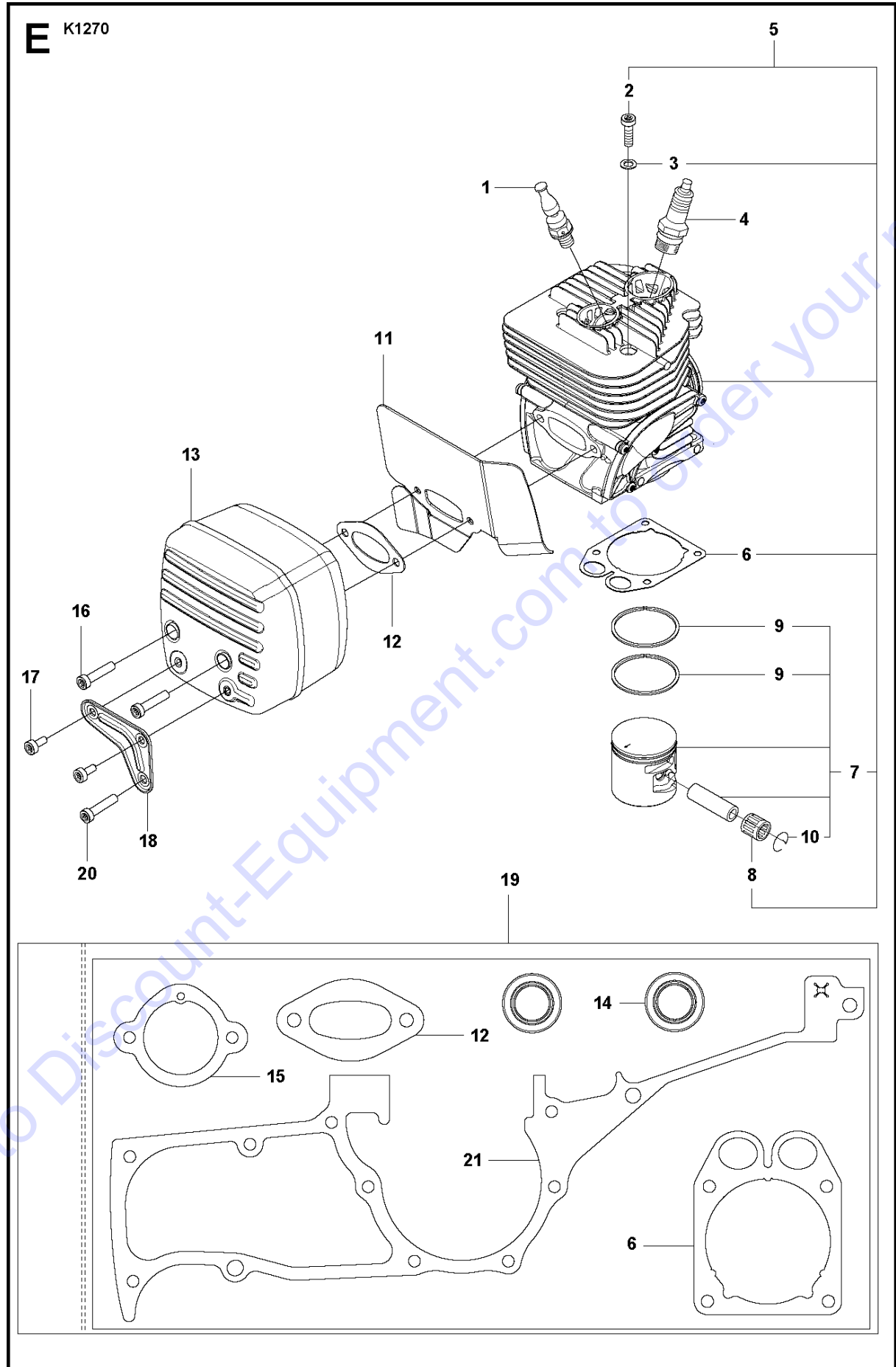

CYLINDER, PISTON & MUFFLER

K1270, K1270 Rail, 2016-07

Ref	Part No	Description	Remark	QTY	KIT
1	584 91 22-04	DECOMPRESSION VALVE		1	
2	516 00 24-01	SCREW UNC		4	5
3	503 23 00-05	WASHER		4	5
4	503 23 51-09	SPARK PLUG	RCJ 6Y	1	
5	582 58 23-01	CYLINDER ASSY	Incl. 6 - 8	1	
6	587 53 62-01	GASKET		1	5,19
7	587 82 98-02	PISTON ASSY	Incl. 9 - 10	1	5
8	503 13 29-01	NEEDLE HOLDER		1	5
9	587 83 00-01	PISTON RING		2	5
10	737 44 13-00	CIRCLIP		2	5
11	587 53 63-01	HEAT DEFLECTOR		1	
12	585 28 09-01	GASKET		1	19
13	505 41 79-05	MUFFLER ASSY	Incl. 14 - 15	1	
14	503 26 02-05	SEALING RING		2	19
15	579 85 11-01	GASKET		1	19
16	544 21 84-07	SCREW ITXSCM		2	
17	503 21 53-12	SCREW ITXSCM		2	
18	502 85 08-01	SUPPORT		1	
19	582 45 48-01	GASKET KIT		1	
20	544 21 84-20	SCREW ITXSCM		1	
21	582 35 00-01	GASKET		1	19

Go to Discount-Equipment.com to order your parts

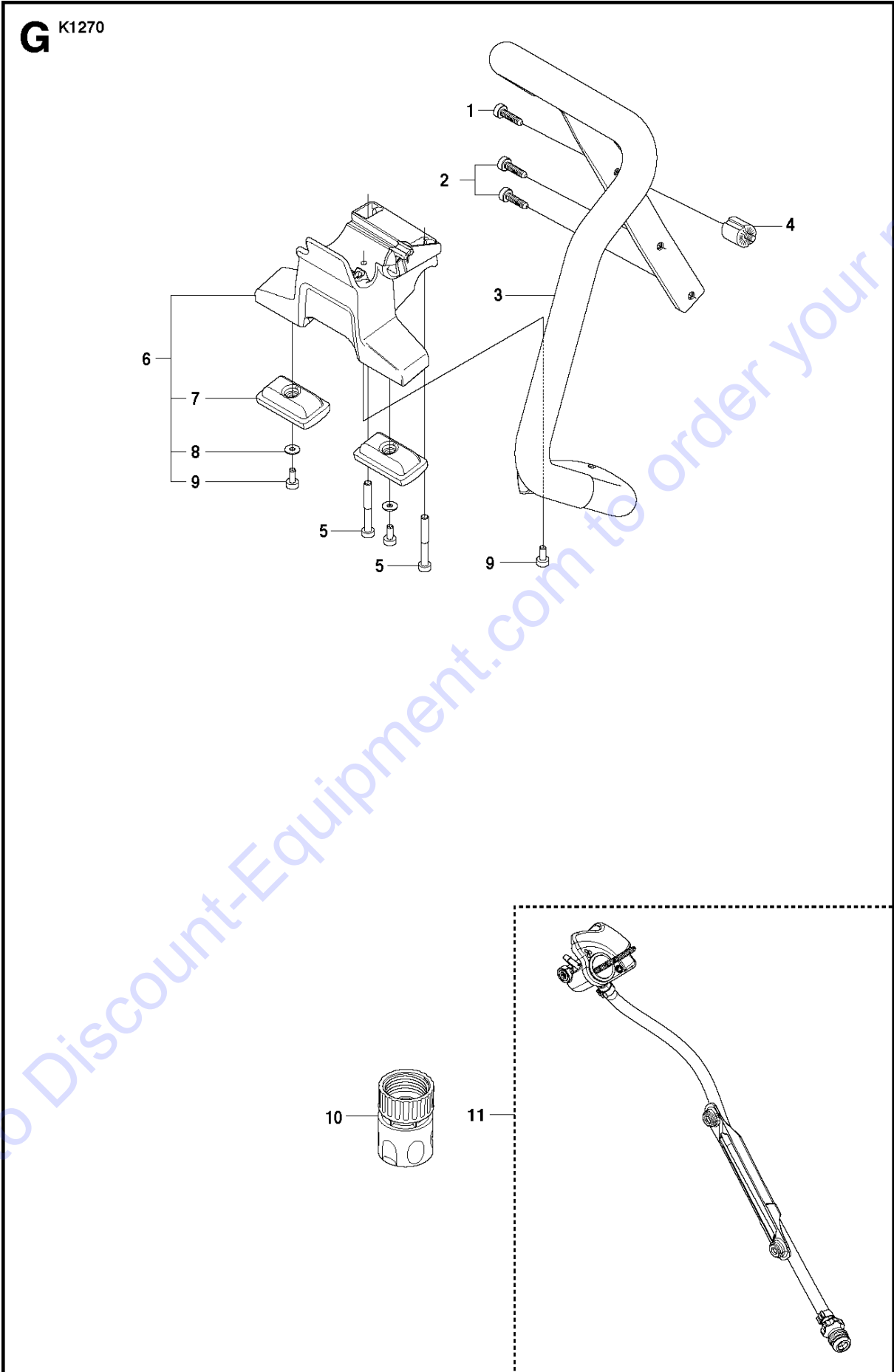

HANDLE

K1270, K1270 Rail, 2016-07

Ref	Part No	Description	Remark	QTY	KIT
1	503 21 53-12	SCREW ITXSCM		1	
2	503 21 54-20	SCREW ITXSCT		2	
3	521 95 48-01	HANDLE		1	
4	501 26 97-05	ANTIVIBRATION ELEMENT		1	
5	544 21 84-47	SCREW ITXSCM		2	
6	525 82 04-02	GROUND SUPPORT	Incl. 7 - 9	1	
7	544 81 16-01	BASE		2	6
8	734 11 47-41	WASHER		2	6
9	504 90 94-14	SCREW ITXSCT		3	6
10	503 26 60-03	COUPLER	USA, Canada	1	
10	503 26 60-04	COUPLER		1	
11	581 47 62-09	HOSE KIT		1	

Go to Discount-Equipment.com to order your parts

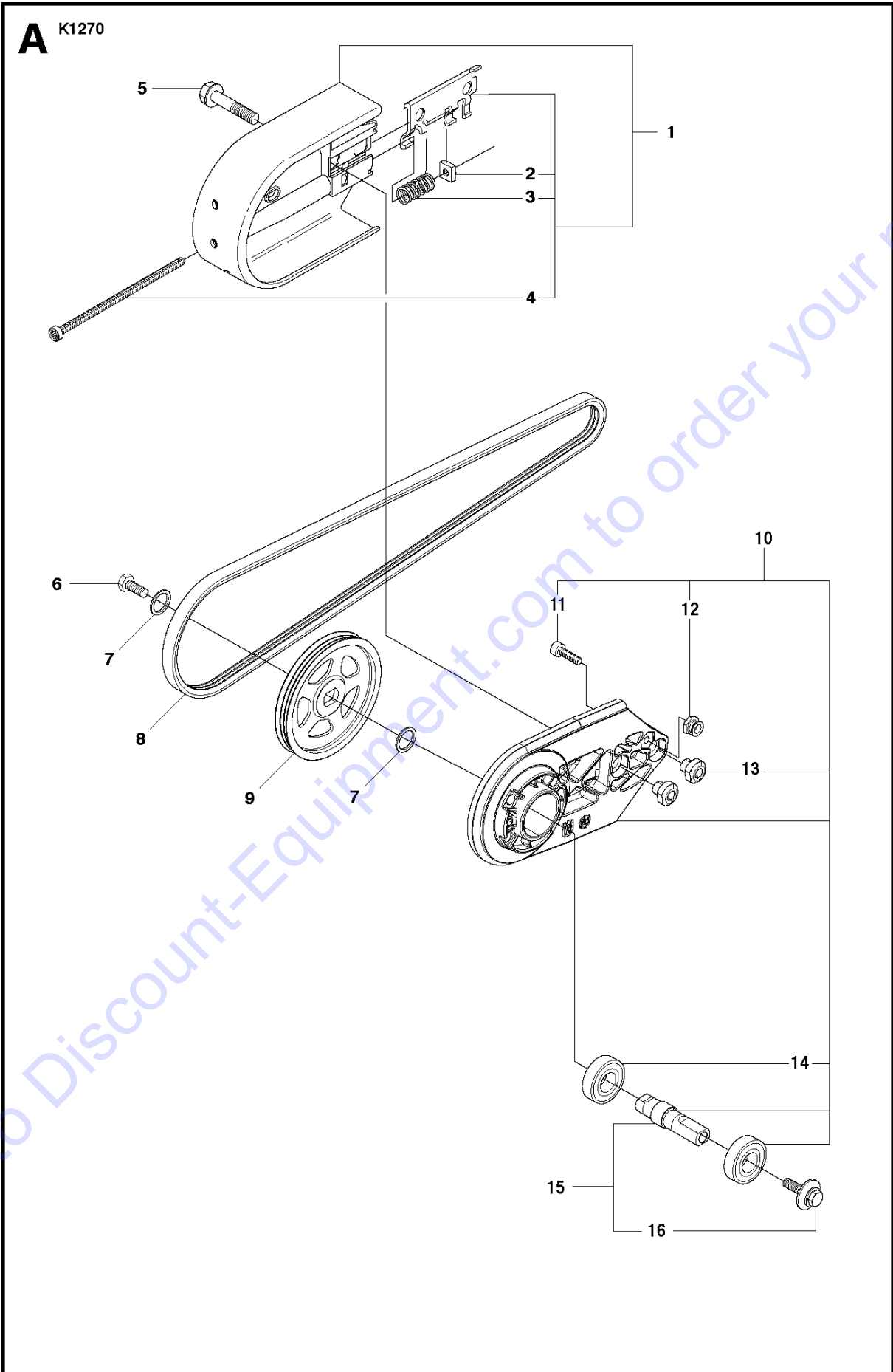

BELT GUARD & PULLEY

K1270, K1270 Rail, 2016-07

Ref	Part No	Description	Remark	QTY KIT	
1	506 27 92-06	BELT GUARD	Incl. 2 - 4	1	
1	506 27 92-07	BELT GUARD	"Rail 14""", Incl. 2 - 4"	1	
1	506 27 92-08	BELT GUARD	"Rail 16""", Incl. 2 - 4"	1	
2	506 40 93-01	NUT		1	1
3	506 26 68-01	COMPRESSION SPRING		1	1
4	503 20 72-05	SCREW CITXSCM		1	1
5	506 28 44-01	SCREW EHHFM		2	
6	503 20 00-45	SCREW EHHFM		1	
7	503 23 01-04	WASHER		2	
8	544 97 63-01	BELT	"14""", 16""", Rail 14"""	1	
8	544 97 63-02	BELT	"Rail 16"""	1	
9	578 11 05-01	PULLEY		1	
10	589 39 03-03	BEARING HOUSING	Incl. 11 - 16	1	
11	505 57 41-16	SCREW ITXSCM		1	10
12	586 41 69-01	STOP		1	10
13	584 78 81-01	NUT		2	10
14	583 95 33-01	BALL BEARING		2	10
15	588 99 24-01	SHAFT	Incl. 16	1	
16	588 65 57-01	SCREW	Included in 10	1	

Go to Discount-Equipment.com to order your parts

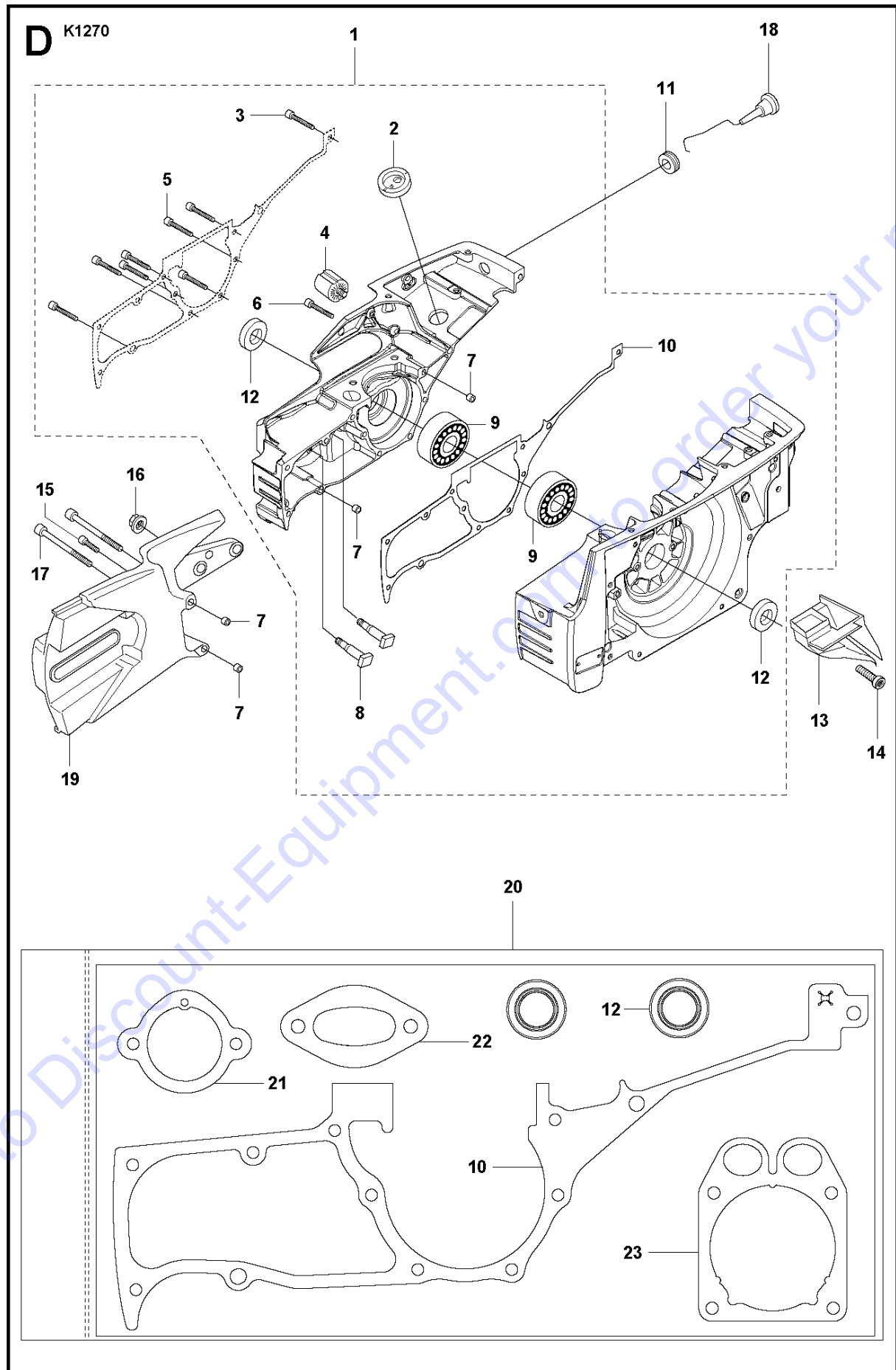

CRANKCASE

K1270, K1270 Rail, 2016-07

Ref	Part No	Description	Remark	QTY	KIT
1	582 60 35-01	CRANKCASE ASSY	Incl. 2-11	1	
2	503 13 20-01	GROMMET		1	1
3	503 21 53-20	SCREW ITXSCM		1	1
4	501 26 97-05	ANTIVIBRATION ELEMENT		1	1
5	503 21 53-41	SCREW ITXSCM		7	1
6	544 21 84-20	SCREW ITXSCM		1	1
7	501 27 08-01	GUIDE BUSHING		4	1
8	501 81 57-01	BAR BOLT		2	1
9	503 25 00-02	BALL BEARING		2	1
10	582 35 00-01	GASKET		1	20,1
11	503 14 54-02	GROMMET		1	
12	503 26 02-05	SEALING RING		2	20,1
13	506 23 70-01	AIR NOZZLE		1	
14	501 98 10-01	SCREW ITXSCM		1	
15	503 21 53-21	SCREW ITXSCM		1	
16	503 22 00-01	HEXAGON NUT		1	
17	503 21 53-65	SCREW ITXSCM		2	
18	506 25 43-02	CHOKE CONTROL		1	
19	506 24 14-04	CUTTER ARM		1	
20	582 45 48-01	GASKET KIT	Incl. 10, 12 21 - 23	1	
21	579 85 11-01	GASKET		1	20
22	585 28 09-01	GASKET		1	20
23	587 53 62-01	GASKET		1	20

Go to Discount-Equipment.com to order your parts

M K1270

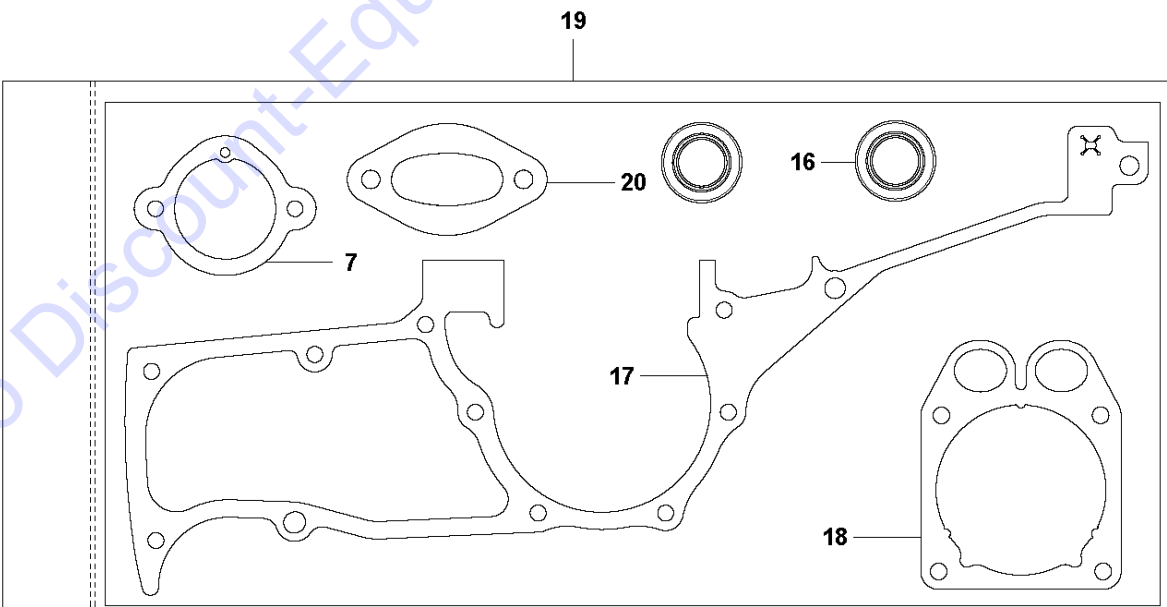
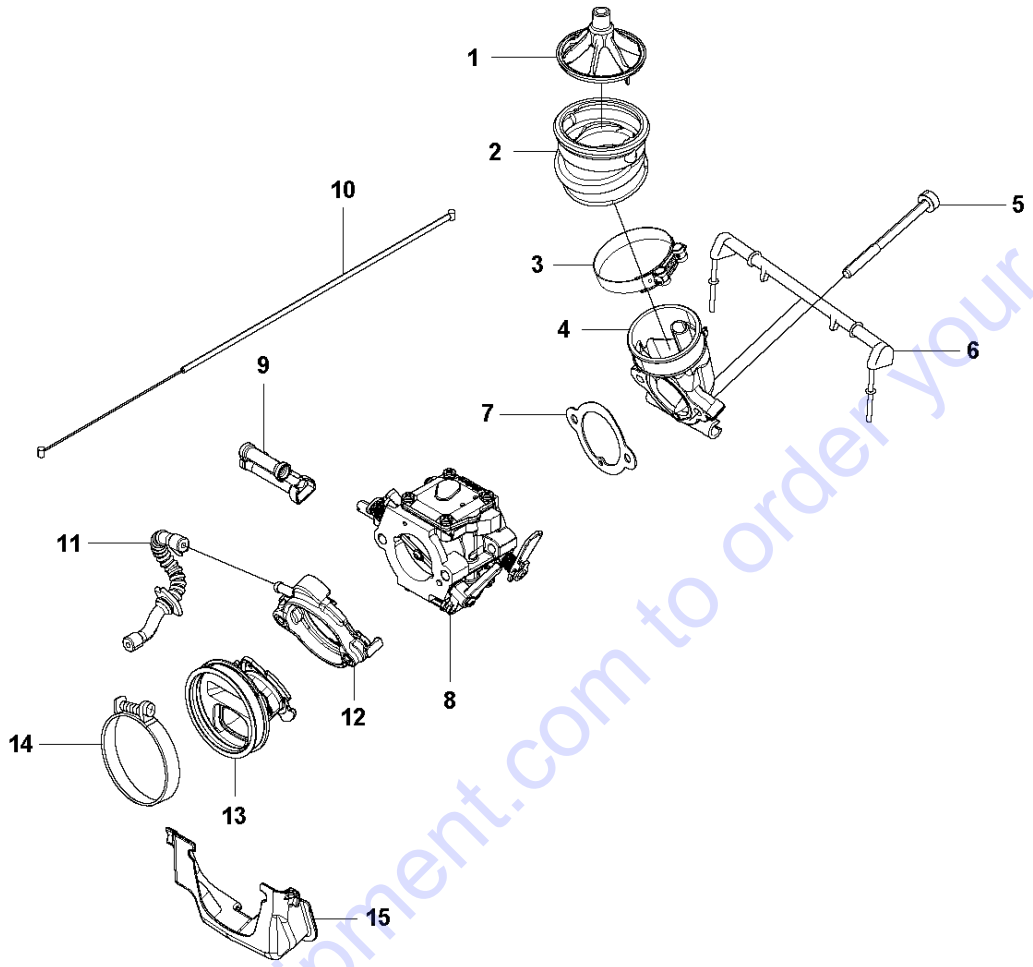

CARBURETOR

K1270, K1270 Rail, 2016-07

Ref	Part No	Description	Remark	QTY	KIT
1	510 24 39-01	FILTER		1	
2	510 24 38-02	BELLOWS		1	
3	505 28 33-07	HOSE CLAMP		1	
4	588 75 07-01	INLET BEND		1	
5	503 21 53-65	SCREW ITXSCM		2	
6	506 25 04-01	SUPPORT		1	
7	579 85 11-01	GASKET		1	20
8	589 02 36-01	CARBURETTOR		1	
9	588 89 20-01	GUIDE SLEEVE		1	
10	506 28 98-02	THROTTLE CABLE ASSY		1	
11	588 70 55-01	IMPULSE HOSE		1	
12	587 53 69-01	FLANGE		1	
13	587 53 68-01	INLET PIPE		1	
14	505 28 33-08	HOSE CLAMP		1	
15	588 63 04-01	INSULATION WALL		1	
16	503 26 02-05	SEALING RING		2	19
17	582 35 00-01	GASKET		1	19
18	587 53 62-01	GASKET		1	19
19	582 45 48-01	GASKET KIT		1	
20	585 28 09-01	GASKET		1	19

Go to Discount-Equipment.com to order your parts

GUARDS

K1270, K1270 Rail, 2016-07

Ref	Part No	Description	Remark	QTY	KIT
1	581 35 19-04	WHEEL GUARD	"14""	1	
1	581 35 19-06	WHEEL GUARD	"16""	1	
2	504 90 94-14	SCREW ITXSCT		2	1
3	578 19 09-01	HANDLE HALF		1	1
4	578 76 09-01	HANDLE HALF		1	1
5	504 90 94-10	SCREW ITXSCT		1	1
6	581 62 03-01	STOP		1	1
7	584 43 77-01	DISC		1	
8	584 43 83-01	SUPPORT FLANGE		1	
9	583 87 44-02	FLANGE	Diam 105mm	1	
9	506 07 09-02	FLANGE WASHER	"Diam 119mm, Japan 14""/16""	1	
10	578 39 82-01	BUSHING	Diam 20/25,4mm	1	
10	581 60 54-03	BUSHING	Diam 30,5mm	1	
10	506 37 96-22	KIT	Diam 22,2mm	1	
11	588 65 57-01	SCREW	M10	1	
12	544 21 84-30	SCREW ITXSCT		4	
13	584 43 82-01	SLEEVE	"14"", Shiny"	4	
13	584 43 82-02	SLEEVE	"16"", Black"	4	
14	584 43 81-01	SPRING		4	
15	584 43 78-01	SHIM		2	
16	584 43 79-01	LINING		1	1
17	584 43 80-01	LINING		1	1
18	581 11 77-06	DECAL	"14""	1	
18	581 11 77-07	DECAL	"16""	1	
19	584 99 26-02	DECAL	"14"", JP"	1	
19	584 99 26-03	DECAL	"16"", JP"	1	
20	582 23 31-01	WASHER		2	
21	582 23 32-01	WASHER		2	

Go to Discount-Equipment.com to order your parts

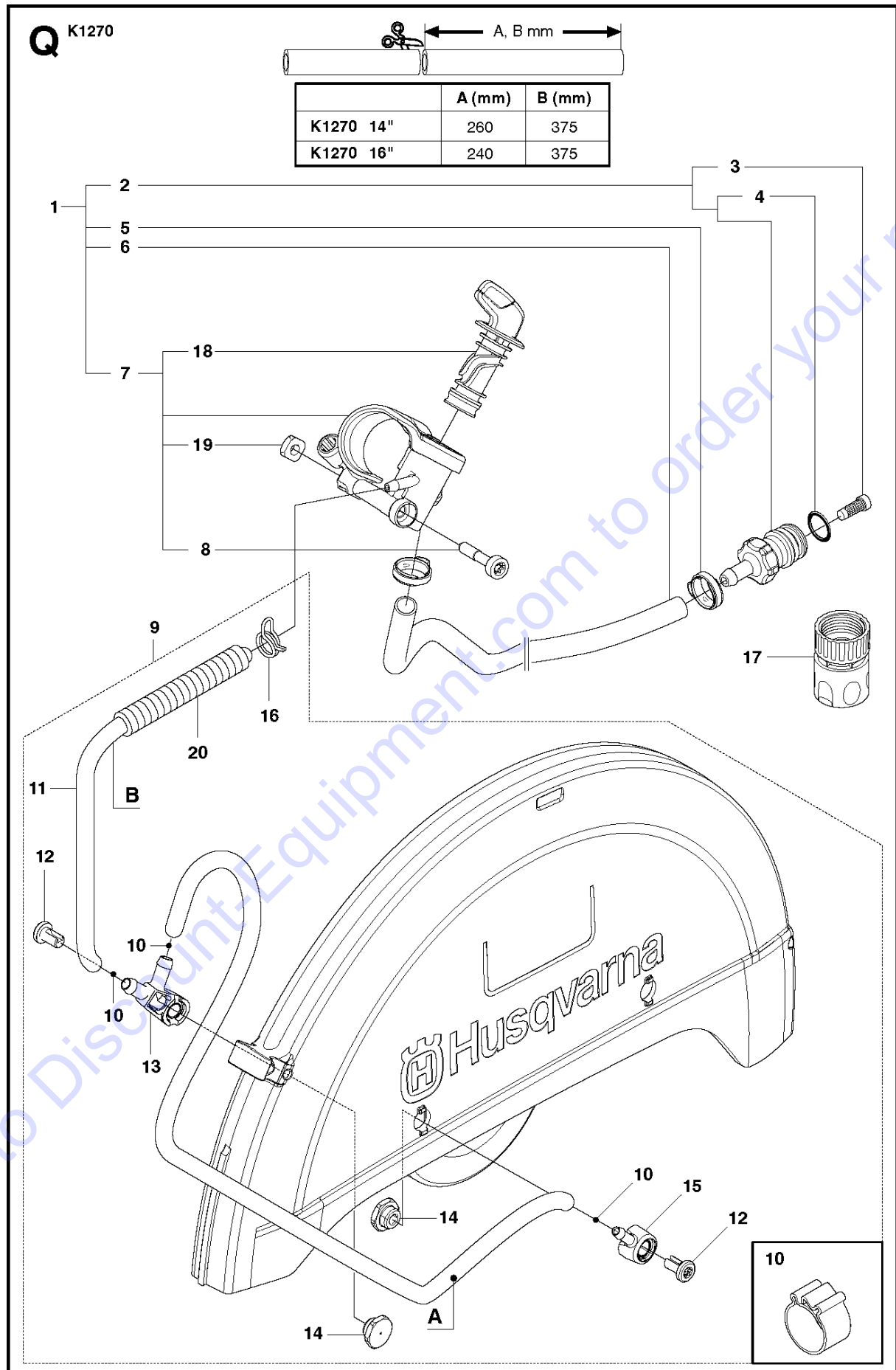

WATER HOSE KIT

K1270, K1270 Rail, 2016-07

Ref	Part No	Description	Remark	QTY KIT
1	581 47 62-09	HOSE KIT		1
2	581 47 83-02	NIPPLE		1 1
3	506 29 88-01	FILTER		1 1,2
4	505 10 35-01	O-RING		1 1,2
5	589 63 86-01	HOSE CLAMP		2 1
6	578 19 81-04	HOSE		1 1
7	578 24 33-04	VALVE ASSY		1 1
8	503 21 53-41	SCREW ITXSCM		1 1,7
9	581 72 15-03	HOSE KIT		1
10	589 63 86-01	HOSE CLAMP		3 9
11	581 89 35-08	HOSE	800mm	1 9
12	504 63 46-01	SCREW ITXSCM		2 9
13	587 38 89-01	HOUSING		1 9
14	576 79 84-02	NIPPLE		2 9
15	587 38 90-01	HOUSING		1 9
16	583 83 30-02	HOSE CLAMP		1 9
17	503 26 60-03	COUPLER	"1/2""	1
17	503 26 60-04	COUPLER	"GHT 3/4""	1
18	581 35 70-01	LEVER ASSY		1 1,7
19	503 22 65-04	SQUARE NUT		1 1,7
20	506 35 27-01	PROTECTIVE SPRING		1

Go to Discount-Equipment.com to order your parts

P K1270

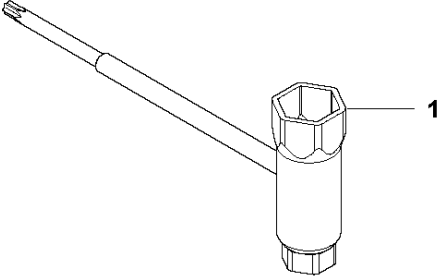

2

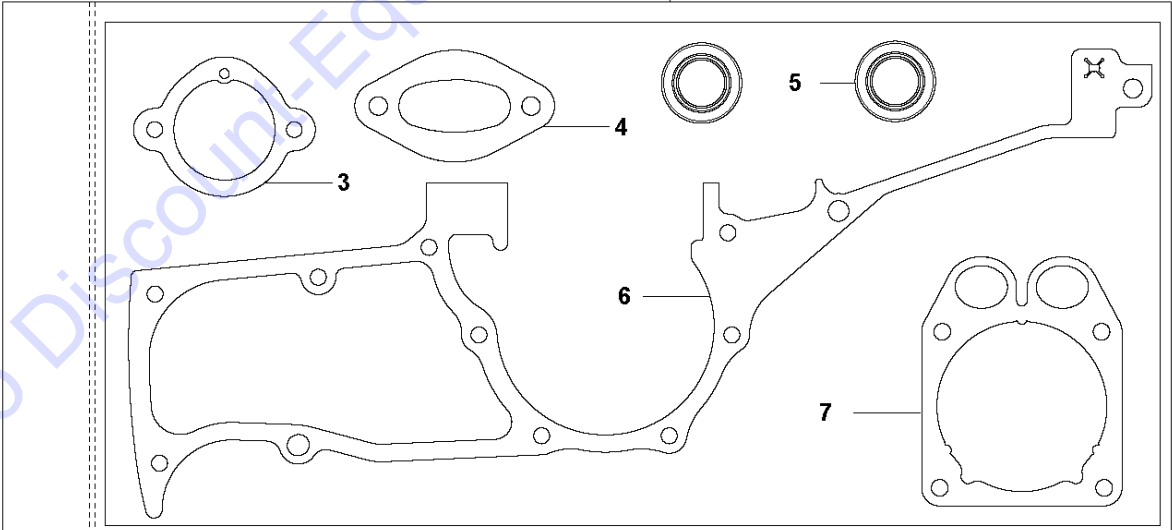

Go to Discount-Equipment.com to order your parts

TOOLS

K1270, K1270 Rail, 2016-07

Ref	Part No	Description	Remark	QTY	KIT
1	506 38 26-01	TOOL	Torx 27	1	
2	582 45 48-01	GASKET KIT	Incl. 3 - 7	1	
3	579 85 11-01	GASKET		1	2
4	585 28 09-01	GASKET		1	2
5	503 26 02-05	SEALING RING		2	2
6	582 35 00-01	GASKET		1	2
7	587 53 62-01	GASKET		1	2

Go to Discount-Equipment.com to order your parts

J K1270

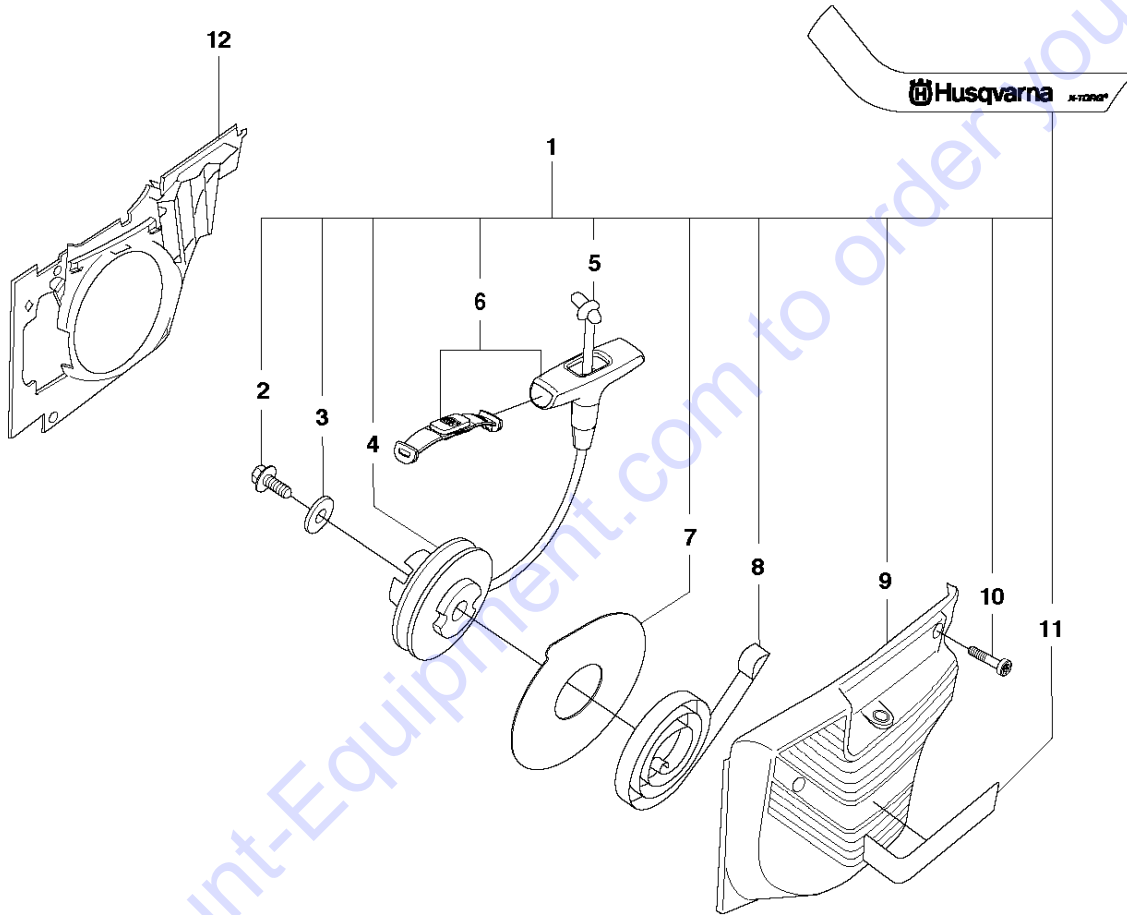

Go to Discount-Equipment.com to order your parts

STARTER

K1270, K1270 Rail, 2016-07

Ref	Part No	Description	Remark	QTY	KIT
1	506 27 55-07	STARTER	Incl. 2 - 11	1	
2	503 21 06-16	SCREW IHST		1	1
3	503 23 43-02	WASHER		1	1
4	501 89 67-04	STARTER PULLEY		1	1
5	506 33 56-25	STARTER CORD		1	1
5	506 33 56-50	STARTER CORD	50 meter	1	1
6	584 25 79-01	STARTER HANDLE ASSY		1	1
7	503 74 36-01	DAMPING DISC		1	1
8	503 13 50-01	RECOIL SPRING		1	1
9	506 25 58-02	STARTER COVER		1	1
10	503 21 53-26	SCREW ITXSCM		4	1
11	582 14 19-01	DECAL		1	1
12	501 89 59-02	AIR CONDUCTOR		1	
12	501 89 59-03	AIR CONDUCTOR	Rail Stop Switch only	1	

Go to Discount-Equipment.com to order your parts

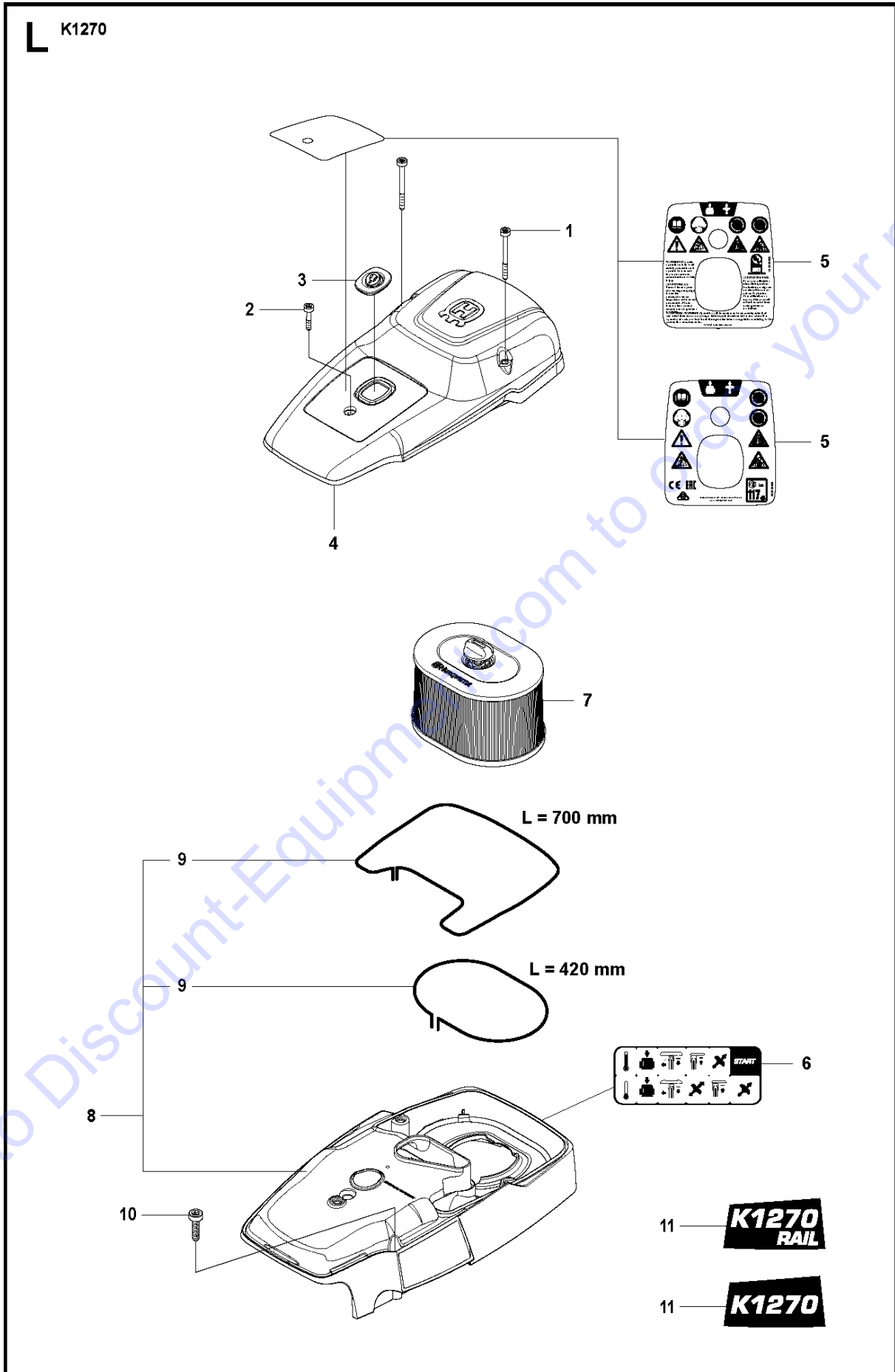

AIR FILTER

K1270, K1270 Rail, 2016-07

Ref	Part No	Description	Remark	QTY	KIT
1	503 21 53-56	SCREW ITXSCM		2	
2	503 21 53-12	SCREW ITXSCM		1	
3	585 42 83-01	PLUG		1	
4	589 02 34-01	FILTER COVER		1	
5	589 02 38-01	DECAL	USA, CANADA, MEXICO	1	
5	589 02 38-03	DECAL	CE	1	
6	544 87 38-02	LABEL		1	
7	510 24 41-03	AIR FILTER	Standard	1	
7	510 24 41-05	AIR FILTER	Rail	1	
8	576 55 32-02	CYLINDER COVER	Incl. 9 - 10	1	
9	525 61 70-04	SEALING		2	8
10	503 21 53-30	SCREW ITXSCM		5	8
11	525 81 69-04	LABEL	K1270 Rail	1	
11	525 81 69-03	LABEL	K1270	1	

Go to Discount-Equipment.com to order your parts

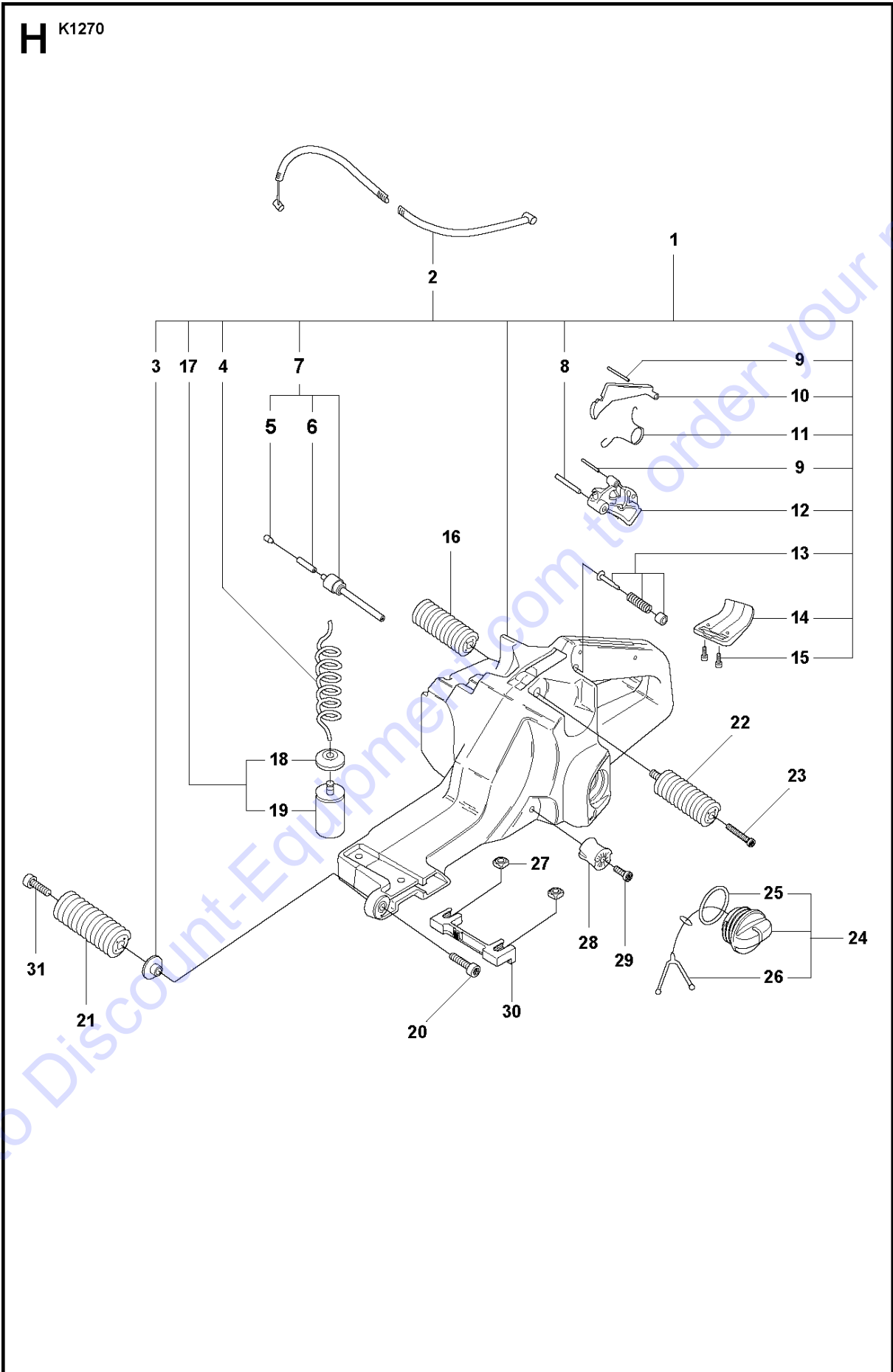

FUEL TANK

K1270, K1270 Rail, 2016-07

Ref	Part No	Description	Remark	QTY	KIT
1	582 62 58-02	FUEL TANK	Incl. 1 - 15, 17	1	
2	506 28 98-02	THROTTLE CABLE ASSY		1	1
3	503 14 08-01	BUSHING		1	1
4	581 75 62-03	FUEL HOSE		1	1
5	504 35 72-01	PLUG		1	1, 7
7	588 99 27-01	TANK VENT ASSY		1	1
8	720 12 78-06	PARALLEL PIN		1	1
9	720 12 40-20	PARALLEL PIN		1	1
10	503 13 16-02	THROTTLE LOCKOUT		1	1
11	503 13 18-01	SPRING		1	1
12	503 13 36-03	THROTTLE CONTROL ASSY		1	1
13	503 14 23-01	SPÄRRSTIFT RES		1	1
14	506 23 34-01	SUPPORT		1	1
15	503 21 45-16	SCREW CRCSFT		2	1
16	585 22 63-01	ANTIVIBRATION ELEMENT		1	
17	506 26 41-11	FUEL FILTER	Incl. 18 - 19	1	1
18	506 27 11-01	HOSE CLAMP		1	17,1
19	506 26 41-01	FUEL FILTER		1	17,1
20	503 21 53-20	SCREW ITXSCM		2	
21	503 13 27-02	ANTIVIBRATION ELEMENT		1	
22	585 22 64-01	ANTIVIBRATION ELEMENT		1	
23	544 21 84-20	SCREW ITXSCM		2	
24	506 25 59-06	TANK CAP ASSY	Incl. 25 - 26	1	
25	506 29 21-01	GASKET		1	24
26	503 57 89-01	HOLDER		1	24
27	505 42 04-01	NUT		2	
28	501 81 47-01	ANTIVIBRATION ELEMENT		1	
29	503 21 53-12	SCREW ITXSCM		1	
30	574 51 22-01	NUT LOCKING		1	
31	503 21 53-25	SCREW ITXSCM		1	

Go to Discount-Equipment.com to order your parts

S K1270

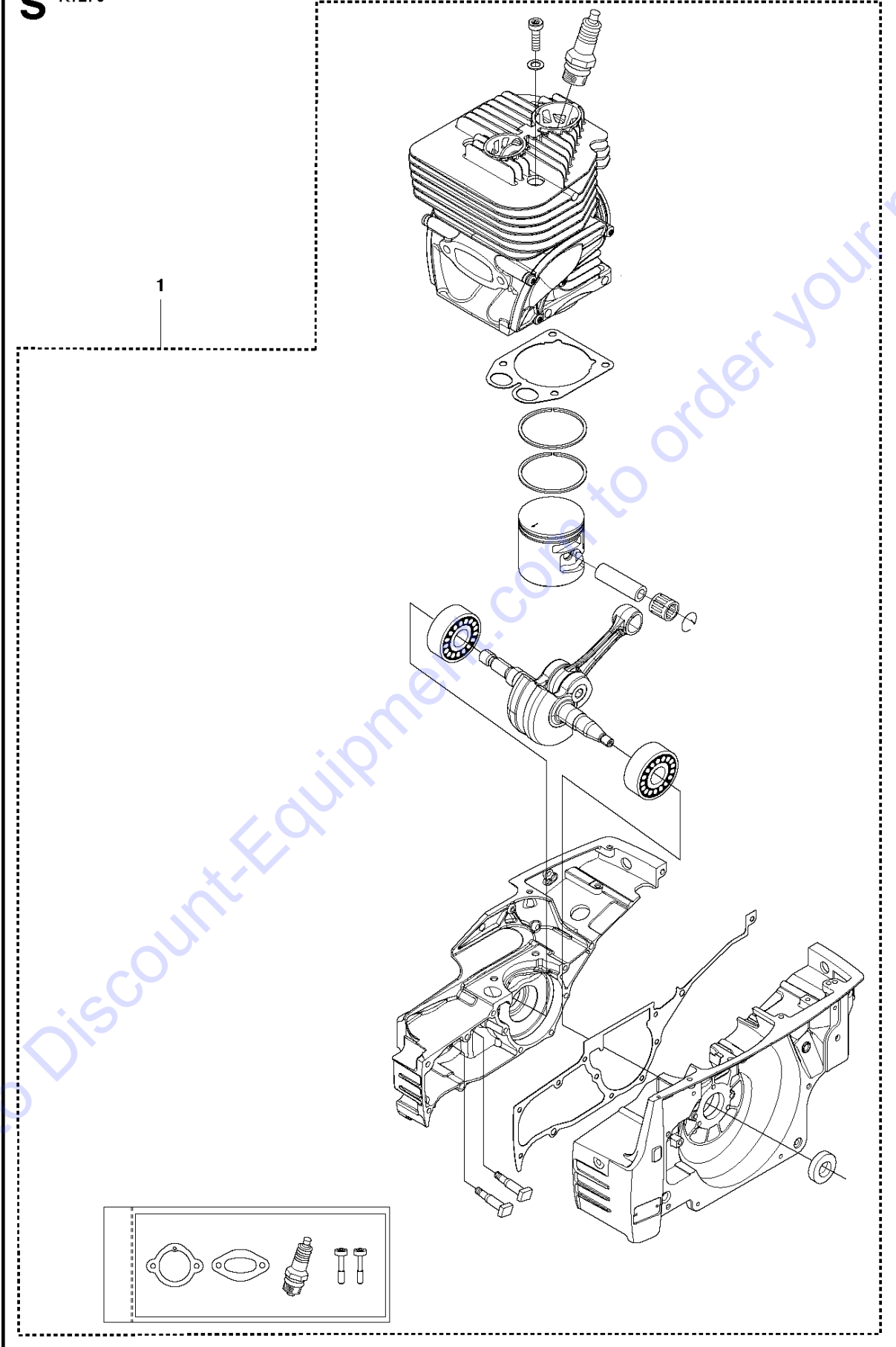

Go to Discount-Equipment.com to order your parts

Ref	Part No	Description	Remark	QTY KIT
1	582 41 50-02	CRANKCASE		1

Go to Discount-Equipment.com to order your parts

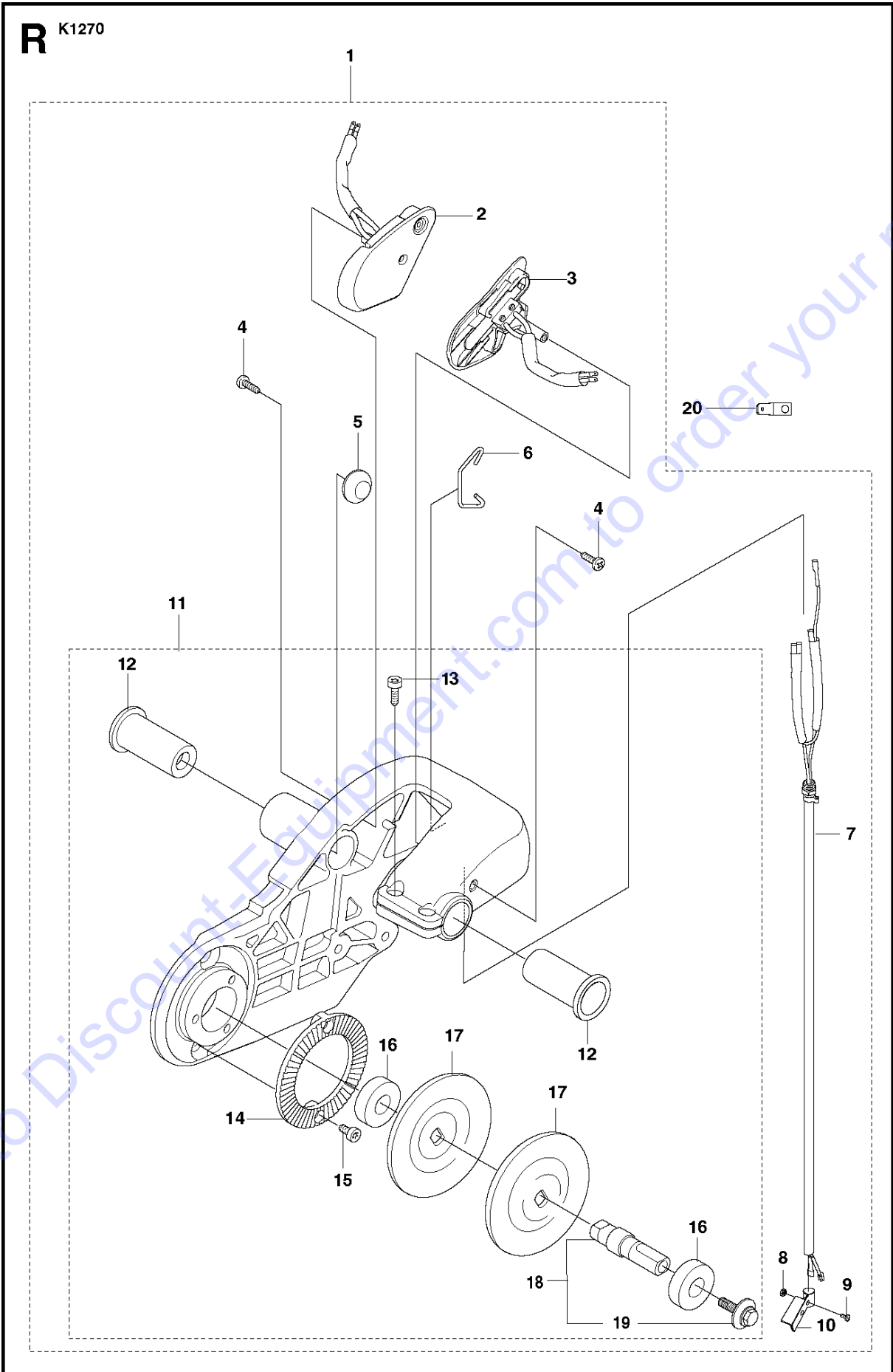

RAIL

K1270, K1270 Rail, 2016-07

Ref	Part No	Description	Remark	QTY	KIT
1	576 66 57-06	BEARING HOUSING ASSY	"14"" Rail Stop Switch,"	1	
2	506 35 91-04	STOP SWITCH	RH	1	1
3	506 35 91-03	STOP SWITCH	LH	1	1
4	729 52 91-71	SCREW CRPANT		2	1
5	506 35 96-01	SPACING BLOCK		1	1
6	501 35 43-01	CLIP		1	1
7	506 35 90-01	WIRING		1	1
8	732 25 12-01	HEXAGON LOCKING NUT		1	1
9	724 12 87-59	SCREW CRPANM		1	1
10	506 35 80-01	BRACKET		1	1
11	576 66 57-05	BEARING HOUSING ASSY	"14"" Rail, "	1	1
11	576 66 57-07	BEARING HOUSING ASSY	"16"" Rail, "	1	1
11	576 66 57-08	BEARING HOUSING ASSY	"16"" Rail USA, "	1	1
12	506 22 75-01	SLEEVE		2	1, 11
13	503 20 02-16	SCREW IHSCFM		2	1, 11
14	506 28 84-01	SCREEN		1	1, 11
15	503 21 53-10	SCREW ITXSCM		2	1, 11
16	583 95 33-01	BALL BEARING		2	1, 11
17	506 07 09-02	FLANGE WASHER	Incl. 18	1	1, 11
18	588 99 24-01	SHAFT		1	1, 11
19	590 50 38-01	SCREW		1	1, 18, 11
20	535 03 94-01	CONNECTION		1	

Go to Discount-Equipment.com to order your parts

F K1270

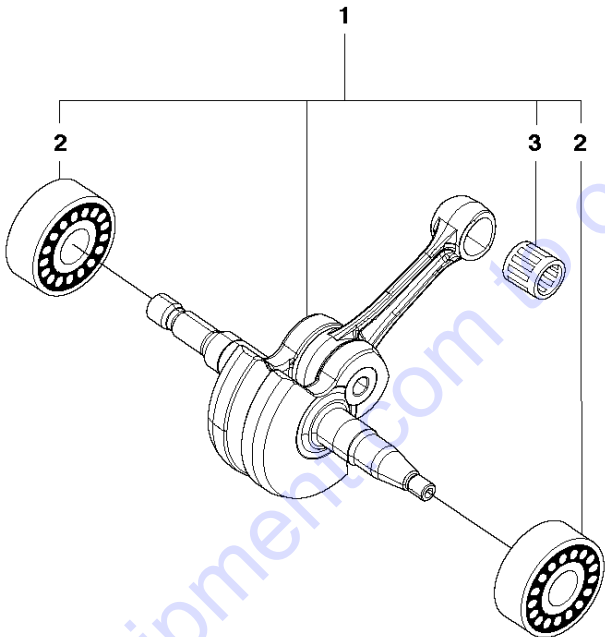

Go to Discount-Equipment.com to order your parts

CRANKSHAFT

K1270, K1270 Rail, 2016-07

Ref	Part No	Description	Remark	QTY	KIT
1	577 34 38-03	CRANKSHAFT	Incl. 2, 3	1	
2	503 25 00-02	BALL BEARING		2	1
3	503 13 29-01	NEEDLE HOLDER		1	1

Go to Discount-Equipment.com to order your parts

N K1270

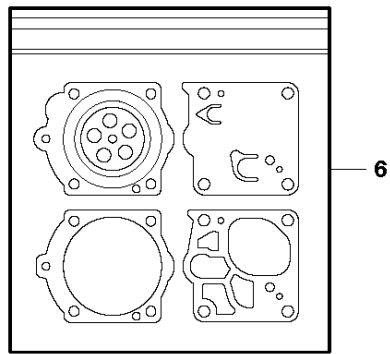
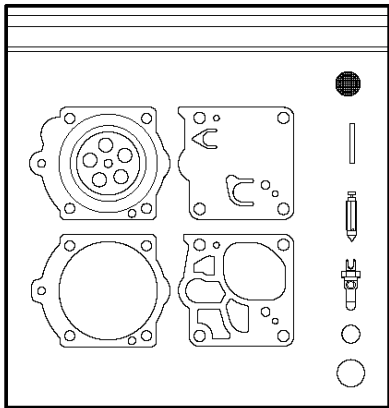
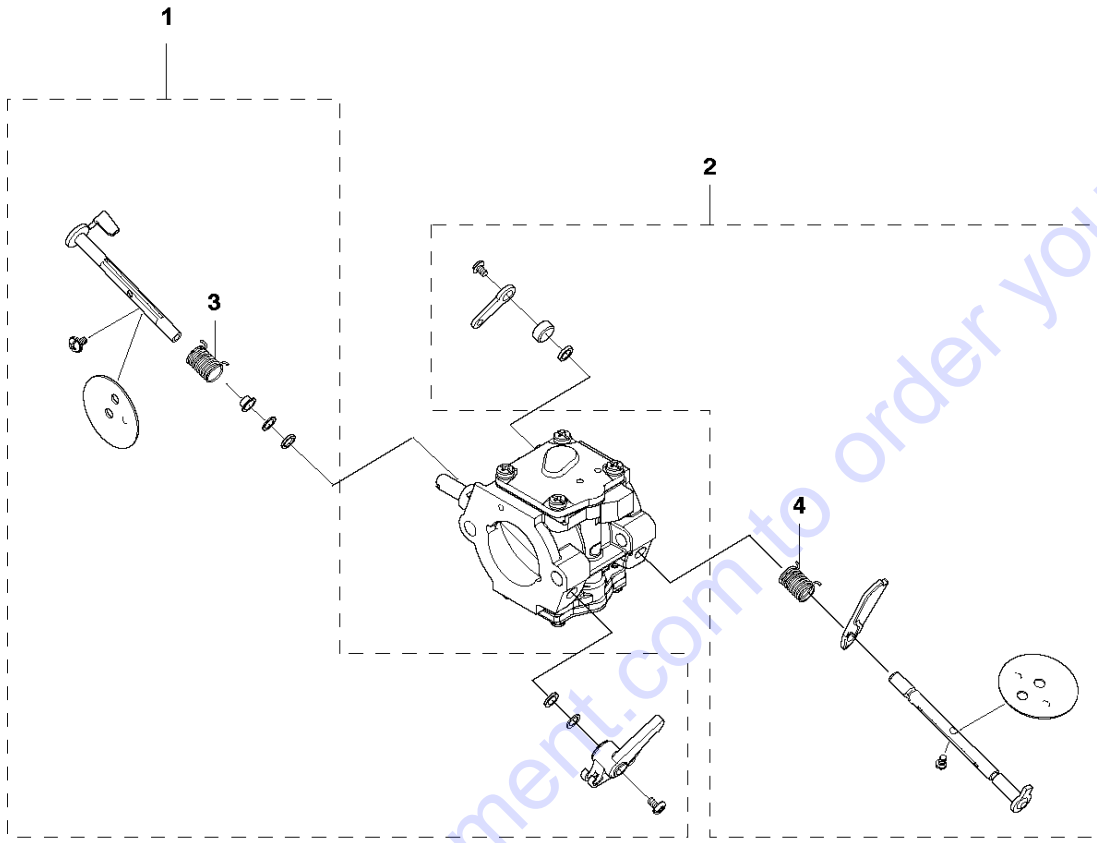

Go to Discount-Equipment.com to order your parts

CARBURETOR DETAILS

K1270, K1270 Rail, 2016-07

Ref	Part No	Description	Remark	QTY	KIT
1	582 72 95-01	THROTTLE SHAFT		1	
2	582 72 97-01	CHOKE SHAFT		1	
3	579 79 15-01	SPRING		1	1
4	579 79 16-01	SPRING		1	2
5	582 60 65-01	REPAIR KIT		1	
6	503 59 74-03	GASKET KIT		1	

Go to Discount-Equipment.com to order your parts

C K1270

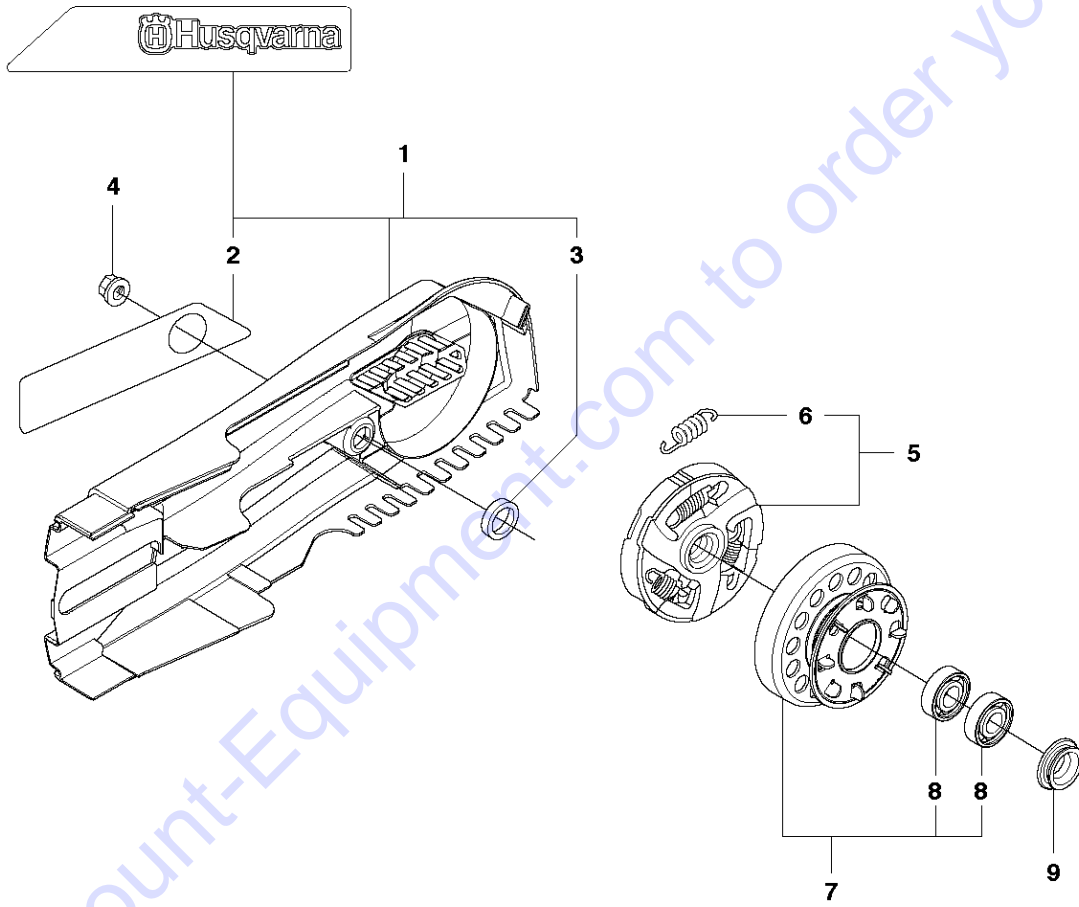

Go to Discount-Equipment.com to order your parts

BELT GUARD

K1270, K1270 Rail, 2016-07

Ref	Part No	Description	Remark	QTY	KIT
1	506 27 17-04	BELT GUARD	Incl. 2, 3	1	
2	544 87 36-01	LABEL		1	1
3	506 26 84-01	SPACING SLEEVE		1	1
4	503 22 00-01	HEXAGON NUT		1	
5	503 14 49-01	CLUTCH ASSY	Incl. 6	1	
6	503 14 51-01	CLUTCH SPRING		3	5
7	588 80 92-01	DRIVING PULLEY ASSY	"14"". Incl. 8"	1	
7	588 80 92-02	DRIVING PULLEY ASSY	"16"". Incl. 8"	1	
8	525 83 18-01	BALL BEARING		2	7
9	587 53 64-01	SPACING SLEEVE		1	

Go to Discount-Equipment.com to order your parts

GUARDS

K1270, K1270 Rail, 2016-07

Ref	Part No	Description	Remark	QTY KIT	
1	506 34 05-54	BLADE GUARD	"14"" Rail"	1	
1	506 34 05-56	BLADE GUARD	"16"" Rail"	1	
2	506 26 63-02	LINING		1	1
3	503 21 53-20	SCREW ITXSCM		1	1
4	506 34 46-02	HANDLE		1	1
5	506 26 64-01	SCREEN		1	
6	506 26 65-01	FLANGE		1	
7	505 57 41-16	SCREW ITXSCM		3	
8	506 32 48-01	SUPPORT FLANGE		1	
9	583 87 44-02	FLANGE	Diam 105	1	
9	506 07 09-02	FLANGE WASHER	Diam 119	1	
10	506 37 96-20	KIT	Diam 20	1	
10	506 37 96-22	KIT	Diam 22,2	1	
10	506 37 96-25	KIT	Diam 25	1	
10	506 02 88-30	BUSHING	DIAM 30,5	1	
11	588 65 57-01	SCREW	M10	1	
12	506 28 41-12	LABEL	"14"" Diam 20 mm"	1	
12	506 28 41-14	LABEL	"14""	1	
12	506 28 41-22	LABEL	"16"" Diam 20 mm"	1	
12	506 28 41-24	LABEL	"16""	1	
13	576 12 10-02	DECAL	"14""	1	
13	576 12 10-03	DECAL	"16""	1	

Go to Discount-Equipment.com to order your parts

PARTS FINDER

**Search Website
by Part Number**



**Search Manual
Library For Parts
Manual & Lookup Part
Numbers – Purchase
or Request Quote**

Search Manuals

Enter your information to help us find the right parts manual for your machine.

* Brand:

* Model:

* Serial:

* Part Number:

SEARCH

**Can't Find Part or
Manual? Request Help
by Manufacturer,
Model & Description**

Parts Order Form

Please fill in the following information to help us find the right part for your machine.

MANUFACTURER:

MODEL:

DESCRIPTION:

DATE:

TIME:

PHONE:

EMAIL:

ADDRESS:

CITY:

STATE:

ZIP:

COUNTRY:

SEARCH

Discount-Equipment.com is your online resource for quality parts & equipment.

Florida: **561-964-4949** Outside Florida TOLL FREE: **877-690-3101**

Need parts?

Click on this link: <http://www.discount-equipment.com/category/5443-parts/> and choose one of the options to help get the right parts and equipment you are looking for. Please have the machine model and serial number available in order to help us get you the correct parts. If you don't find the part on the website or on one of the online manuals, please fill out the request form and one of our experienced staff members will get back to you with a quote for the right part that your machine needs.

We sell worldwide for the brands: Genie, Terex, JLG, MultiQuip, Mikasa, Essick, Whiteman, Mayco, Toro Stone, Diamond Products, Generac Magnum, Airman, Haulotte, Barreto, Power Blanket, Nifty Lift, Atlas Copco, Chicago Pneumatic, Allmand, Miller Curber, Skyjack, Lull, Skytrak, Tsurumi, Husquvarna Target, Stow, Wacker, Sakai, Mi-T-M, Sullair, Basic, Dynapac, MBW, Weber, Bartell, Bennar Newman, Haulotte, Ditch Runner, Menegotti, Morrison, Contec, Buddy, Crown, Edco, Wyco, Bomag, Laymor, EZ Trench, Bil-Jax, F.S. Curtis, Gehl Pavers, Heli, Honda, ICS/PowerGrit, IHI, Partner, Imer, Clipper, MMD, Koshin, Rice, CH&E, General Equipment, Amida, Coleman, NAC, Gradall, Square Shooter, Kent, Stanley, Tamco, Toku, Hatz, Kohler, Robin, Wisconsin, Northrock, Oztec, Toker TK, Rol-Air, APT, Wylie, Ingersoll Rand / Doosan, Innovatech, Con X, Ammann, Mecalac, Makinex, Smith Surface Prep, Small Line, Wanco, Yanmar