



# TRACK LOADERS

**RADIAL LIFT**



**1750RT ▲ 2100RT**



# IN THE BEGINNING

**What began in the 19th century as an agricultural implement manufacturer has grown into a 21st century compact equipment powerhouse – Mustang Compact Equipment.**

Known in the early years as the Owatonna Manufacturing Company, Mustang was among the first to make what is known today as the skid steer loader. Since that time, Mustang has combined old-school experience with innovative processes to offer one of the broadest lines of compact equipment available today.

**MUSTANG. THE ORIGINAL WORKHORSE.**

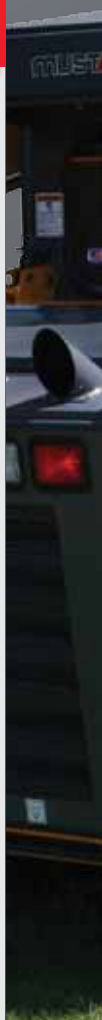

# HOME-RAISED THOROUGHBREDS



Since blazing into the track loader market in 2001, Mustang has learned a thing or two about what it takes to be an industry leader. Combine this expertise with input from some of the market's heaviest track loader users, and you get the all-new, home-raised RT Series Track Loaders from Mustang.

Built with the same level of quality and workmanship found on the Mustang skid steer loaders, the RT Series Track Loaders provide patented, industry-exclusive features sure to blaze a new trail in the track loader market.

**RELIEVE TENSION** ▲ HydraTrac™ Automatic Track Tensioning system automatically tensions the tracks when the engine is started and during operation.

**YANMAR DIESEL ENGINES** ▲ The 1750RT naturally aspirated engine provides 179 ft.-lbs. (242.7 Nm) of torque and 68.4 hp (51 kW) and the 2100RT engine is turbocharged and provides 206 ft.-lbs. (297.3 Nm) of torque and 70.7 hp (52.7 kW) for class leading tractive effort and fuel efficiency.

**RADIAL-LIFT, LOW PROFILE BOOM** ▲ High-strength, low-profile design increases operator visibility and provides additional reach at trailer loading and unloading heights.

**REDESIGNED CAB INTERIOR** ▲ Ergonomic, adjustable environment provides class leading operator comfort and safety.



**1750RT ▲ 2100RT**

# TAKE OUT THE GUESSWORK



## 1750RT 2100RT

Reduce the worries of proper track tension with the HydraTrac™ Automatic Track Tensioning System.

**AUTO TENSION** ▲ The Mustang-patented HydraTrac™ Automatic Track Tensioning System dynamically maintains proper tension during operation and releases tension when the engine is turned off. By ensuring proper track tension, track and bearing life is increased.

**TRACK SERVICE** ▲ Tracks can be easily removed in the field without the use of tools by flipping the track service switch located in the engine compartment.



ENGINE NOT RUNNING



ENGINE RUNNING



**OPTIMIZED RADIAL BOOM DESIGN** ▲ offers increased strength and more than 127.5" (3239 mm) of lift height – higher than any competitor in their respective weight classes.



**5X5 RIDE CONTROL SYSTEM** ▲ offers five control settings that change five parameters to suit operator preference and application requirements.



**DEDICATED, WELDED TRACK LOADER CHASSIS** ▲ aids in superior weight distribution which enhances stability, grading, tractive effort and ride control.

# RAW PERFORMANCE



**ANTISTALL TECHNOLOGY** ▲ senses machine load electronically, monitoring and adjusting the hydrostatic drive pump resulting in tractive effort of 11,840 lbs. (5371 kN) on the 1750RT and 12,349 lbs. (5606 kN) on the 2100RT.



**HYDRAULIC SYSTEM** ▲ pressure of 3,000 psi (207 bar) delivers high performance and fast cycle times. Lift cylinders incorporate cushioning for smoother operation when lowering the lift arm.



**SERVICEABILITY** ▲ is made easy with a large gas-spring assisted engine cover and tiltable ROPS/FOPS assembly. Patented tilt-out foot pod allows for best-in-class foot well cleanout and easy access to components under the cab.

**1750RT ▲ 2100RT**

# CLIMB INTO THE SADDLE



## EXCELLENT VISIBILITY ▲

A cab-forward design enhances the view to the bucket cutting edge from the operator's seat.



## INSTRUMENTATION ▲

Complicated gauges and cluttered dash readouts are eliminated with a customizable multi-function display.



## SIDE RESTRAINT BARS ▲

Side-folding restraint bars and adjustable arm rests provide personalized comfort and increased safety.



## JOYSTICK CONTROLS ▲

Fully adjustable controls mounted to the operator's seat allows them to move with the operator for precise control.



**PRESSURIZED CAB ▲** An optional pressurized, sealed cab enclosure provides a cleaner, quieter operating environment.

The cab is the operational core for any job. Mustang understands this and provides an operator's station with the options needed to customize it to YOUR needs.





### MULTI-TACH® SYSTEM ▲

standard on all models is this universal-style attachment mounting system that is compatible with most allied attachments.



### POWER-A-TACH® SYSTEM ▲

optional on all models, users quickly install and remove attachments electronically, leaving the seat only to connect auxiliary hydraulics.

# TIME IS MONEY GET ATTACHED

With a wide variety of EDGE® attachments available from your dealer, the RT Series Track Loaders are easily transformed to meet the needs of your business.



**EDGE**  
*Attachments*



FEATURES	1750RT	2100RT
<b>PERFORMANCE</b>		
All-Tach® Mounting System	●	●
HydraTrac™ Track Tensioning	●	●
Power-A-Tach® Mounting System	●	●
Self-Leveling Hydraulic Lift Action	●	●
Selectable Self-Leveling Lift Action	●	●
Two-speed Hydrostatic Drive System	●	●
12-volt battery	●	●
<b>ENGINE</b>		
Engine Alert System with Error	●	●
Engine Automatic Shutdown System	●	●
Grid/Manifold Heater Starter Assist	●	●
Dual-Element Air Cleaner with	●	●
<b>HYDRAULIC SYSTEM</b>		
Auxiliary Hydraulics	●	●
High-Flow Auxiliary Hydraulics	●	●
<b>UNDERCARRIAGE</b>		
Elevated Planetary Final Drives	●	●
Maintenance Free Rollers Each Side	3	4
Single Flange Front/Dual Flange Rear	●	●
Rubber Track Undercarriage System	●	●
Servo-Controlled Hydrostatic Drive	●	●
Dedicated Undercarriage	●	●
<b>STRUCTURE</b>		
Tilt-out Foot Pod	●	●
Back-up Alarm	●	●
Combination Radiator & Hydraulic Oil	●	●
ROPS/FOPS Level II Overhead	●	●
Anti-Vandalism Lock Provisions	●	●
Mechanical Lift Cylinder Lock	●	●
<b>OPERATOR'S STATION</b>		
Pressurized Cab Enclosure with A/C	●	●
Multi-Function Function Display	●	●
5x5 Drive Control System	●	●
Electro-Hydraulic Joystick Controls	●	●
Selectable Control Pattern Configuration	●	●
Variable Speed Control, Selectable On	●	●
Foot Throttle	●	●
Full-Suspension Seat	●	●

● STANDARD ● OPTIONAL ● EXCLUSIVE – STD.

**1750RT ▲ 2100RT**

SPECIFICATIONS		1750RT	2100RT
DIMENSIONS	A. Overall Operating Height – Fully Raised (mm)	168" (4267)	172" (4369)
	B. Height to Hinge Pin – Fully Raised (mm)	127.5" (3239)	128" (3251)
	C. Reach – Fully Raised (mm)	34.5" (876)	37" (340)
	D. Dump Angle – Fully Raised	40.2°	39°
	E. Dump Height – Fully Raised (mm)	98" (2489)	95.7" (2431)
	F. Maximum Rollback Angle – Fully Raised	102.5°	102.5°
	G. Overall Height at ROPS (mm)	82.8" (2103)	83.1" (2111)
	H. Overall Length w/ Bucket – Std. c-wt. (mm)	144.0" (3658)	152.3" (3868)
	I. Overall Length w/o Bucket – Std. c-wt. (mm)	110.8" (2814)	114.5" (2908)
	J. Specified Height (mm)	67.5" (1715)	67.7" (1720)
	K. Reach at Specified Height (mm)	31.1" (790)	31.8" (808)
	L. Dump Angle at Specified Height	75°	75°
	M. Maximum Rollback Angle at Ground	30°	30°
	N. Carry Position (mm)	7" (179)	7" (179)
	O. Maximum Rollback Angle at Carry Position	33°	33°
	P. Digging Position – Below Ground (mm)	-0.3" (7.6)	-0.2" (5.1)
	Q. Angle of Departure with Std. c-wt.	30.4°	29.2°
	R. Ground Clearance (mm)	13.3" (343)	13" (330)
	S. Track Gauge (mm)	51.7" (1313)	51.7" (1313)
	T. Track Shoe Width (mm)	12.6" (320)	17.7" (450)
	U. Crawler Base (mm)	54.8" (1392)	58.4" (1483)
	V. Overall Width – Less Bucket (mm)	64.4" (1636)	69.5" (1765)
	W. Bucket Width (mm)	65.9" (1674)	73.9" (1877)
	X. Clearance Radius – Front With Bucket (mm)	91.4" (2322)	98.1" (2492)
	Z. Clearance Radius – Rear w/ Std. c-wt. (mm)	62.1" (1577)	64.6" (1641)
	Maximum Rollback at Specified Height	66.8°	66.8°
Angle of Approach	90°	90°	
Grouser Height (mm)	1" (25)	1" (25)	
CAPACITY	Operating Capacity at 35% Tipping Load (kg)	1750 lbs. (794)	2100 lbs. (953)
	Operating Capacity at 50% Tipping Load (kg)	2500 lbs. (1134)	3000 lbs. (1361)
	Tipping Load (kg)	5000 lbs. (2268)	6000 lbs. (2722)
	Operating Weight (kg)	8605 lbs. (3903)	9890 lbs. (4486)
ENGINE	Make/Model	Yanmar / 4TNV98-ZNTBL	Yanmar / 4TNV98-XNMS
	Type	4-Stroke Naturally Aspirated	4-Stroke Turbo
	Displacement (L) / cylinders	203 cu.in. (3.319) / 4	203 cu.in. (3.319) / 4
	Net Horsepower (kW) @ 2500 rpm	68.4 hp (51)	70.7 hp (52.7)
	Peak Torque (Nm) @ 1600 rpm	179 ft.-lbs. (242.7)	206 ft.-lbs. (279.3)
	Oil Pump Capacity (L)	11 qts. (10.4)	11 qts. (10.4)
	Alternator Voltage/Amperage	12V / 95A	12V / 95A
TRACK DRIVES	Drawbar Pull / Tractive Effort (kN)	11,840 lbs. (5371)	12,359 lbs. (5606)
	Track Type / Track Rollers / Roller Type	Rubber / 4 / Steel	Rubber / 4 / Steel
	Track Width (mm)	12.6" (320)	17.7" (450)
	Ground Pressure (bar)	6.2 psi (0.43)	4.7 psi (0.32)
FORCES	Bucket Breakout – Tilt Cylinder (kg)	5189 lbs. (2354)	5492 lbs. (2491)
	Bucket Breakout – Lift Cylinder (kg)	4840 lbs. (2195)	5398 lbs. (2449)
	Ground Speed – Single Speed (km/hr)	5.1 mph (8.2)	5.4 mph (8.7)
	Ground Speed – Two Speed (km/hr)	7.5 mph (12.1)	7.9 mph (12.7)
VOLUME	Fuel Tank (L)	24.4 gal. (92)	24.4 gal. (92)
	Hydraulic Reservoir Tank (L)	11.0 gal. (41.6)	13.8 gal. (52.2)
	Coolant Capacity (L)	3.5 gal. (13.3)	3.8 gal. (14.4)
HYDRAULICS	Auxiliary Hydraulic Flow – Rated Speed (L/min)	18.5 gpm (70.0)	21.8 gpm (82.5)
	High-Flow Hydraulic Flow – Rated Speed (L/min)	34.0 gpm (128.8)	35.9 gpm (135.8)
	Transmission Pump Type	Axial Piston	Axial Piston
	Motor Type	Axial Piston with Planetary Reduction	
	Battery Volts	12V	12V
Cold Cranking Amps at Temperature	850 CCA @ 0°F (-18°C)	850 CCA @ 0°F (-18°C)	

# ORIGINAL WORKHORSE

Mustang authorized dealers offer a full line of compact equipment, backed up by exceptional sales, service and parts support. To find your nearest authorized Mustang dealer, visit the Dealer Locator on [mustangmfg.com](http://mustangmfg.com)

## REFERENCE DIAGRAMS

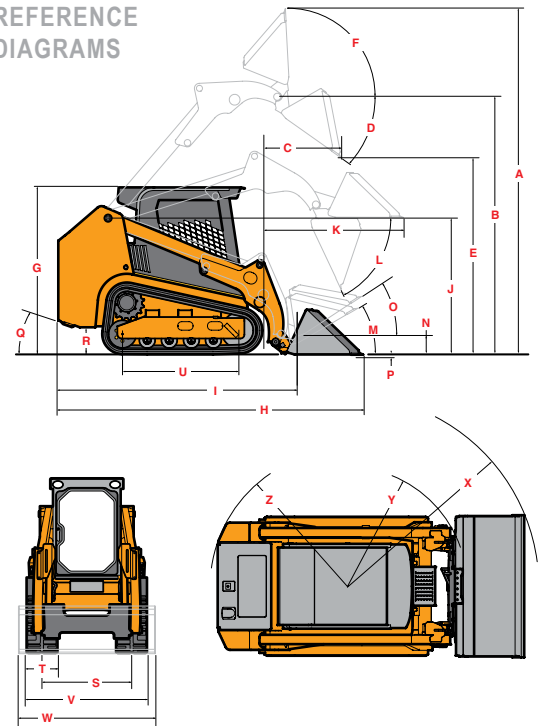

For more information on the RT Series Track Loaders and the rest of the Mustang equipment line, call our hotline at **1-800-628-0491** or visit [mustangmfg.com](http://mustangmfg.com)

# MUSTANG

West Bend, WI 53095 U.S.A. | Tel: 262-334-9461 | Fax: 262-338-7517

FSC

Mustang reserves the right to make changes in specifications at any time without notice or obligation.