



**GB** Operator's manual

Read these instructions carefully and make sure you understand them before using the machine.

**TS 250 X**



**TO PURCHASE THIS PRODUCT PLEASE CONTACT US**



**Equipment Financing and  
Extended Warranties Available**



**Discount-Equipment.com is your online resource for  
commercial and industrial quality parts and equipment sales.**

**561-964-4949**

**visit us on line @ [www.discount-equipment.com](http://www.discount-equipment.com)**

Select an option below to find your Equipment

**Search by Manufacturer**

**Search by Product Type**

**Request a Quote**

We sell worldwide for the brands: Genie, Terex, JLG, MultiQuip, Mikasa, Essick, Whiteman, Mayco, Toro Stone, Diamond Products, Generac Magnum, Airman, Haulotte, Barreto, Power Blanket, Nifty Lift, Atlas Copco, Chicago Pneumatic, Allmand, Miller Curber, Skyjack, Lull, Skytrak, Tsurumi, Husquvarna Target, Stow, Wacker, Sakai, Mi-T-M, Sullair, Basic, Dynapac, MBW, Weber, Bartell, Bennar Newman, Haulotte, Ditch Runner, Menegotti, Morrison, Contec, Buddy, Crown, Edco, Wyco, Bomag, Laymor, EZ Trench, Bil-Jax, F.S. Curtis, Gehl Pavers, Heli, Honda, ICS/PowerGrit, IHI, Partner, Imer, Clipper, MMD, Koshin, Rice, CH&E, General Equipment, Amida, Coleman, NAC, Gradall, Square Shooter, Kent, Stanley, Tamco, Toku, Hatz, Kohler, Robin, Wisconsin, Northrock, Oztec, Toker TK, Rol-Air, APT, Wylie, Ingersoll Rand / Doosan, Innovatech, Con X, Ammann, Mecalac, Makinex, Smith Surface Prep, Small Line, Wanco, Yanmar



EVERY MACHINE IS THOROUGHLY TESTED BEFORE LEAVING THE FACTORY. EACH MACHINE IS SUPPLIED WITH A COPY OF THIS MANUAL. OPERATORS OF THIS EQUIPMENT MUST READ AND BE FAMILIAR WITH THE SAFETY WARNINGS. FAILURE TO OBEY WARNINGS MAY RESULT IN INJURY OR DEATH. FOLLOW INSTRUCTIONS STRICTLY TO ENSURE LONG SERVICE IN NORMAL OPERATION.

## CONTENTS

Symbol Definitions.....	3 - 5
Hearing Hazard Warning.....	5
Dust Warning.....	6
Decal Descriptions and Locations.....	6 - 7
Safety Warnings - DOs & DO NOTs.....	8 - 9

## Figures:

Figure 1.....	10
Figure 2.....	10
Figure 3.....	14
Figure 4.....	16

## Instructions:

1. Features.....	11
2. Benefits.....	11
3. Machine Set-Up.....	11 - 13
4. Operating Procedure.....	13
5. Adjustable Lockbar With Depth Linking Protection.....	14
6. Manual Thermal Overload.....	14
7. Recommended Extension Cords.....	14
8. Alignment Procedures.....	15
9. Profile Wheel Set-Up and Use.....	15
10. Plunge Cutting.....	15
11. Maintenance Procedures.....	15
12. Water Pump, Trouble Shooting Procedure.....	16
13. Repairs & V-Belt Tensioning with Cam Adjustment.....	16
14. Spare Parts.....	16
15. Tile Cutting Accessories.....	17

Wiring Diagrams.....	18 - 19
Warranty.....	21

## NOTE:

**Part Numbers that have an ASTERISK (\*) suffix may not be active 9-digit numbers. The '542' prefix have been added to current 6-digit part numbers and '0' to 8-digit part numbers.**

# Symbol Definitions

## Symboles

### Definición De Los Simbolos

---



- Please read the instructions for use prior to operating the machine for the first time.
- Avant toute mise en service, lire attentivement la notice et se familiariser avec la machine.
- Antes de la puesta en marcha, lea detenidamente las instrucciones y familiarícese con la máquina.



- Mandatory
- Obligatoire
- Obligatorio



- Indication
- Indicazione
- Indicación



- Prohibition
- Interdiction
- Prohibición



- Warning Triangle
- Triangle d'avertissement
- Triángulo De Advertencia



- Wear Eye Protection
- Port obligatoire des lunettes de protection
- Usar Gafas De Protección



- Wear Head Protection
- Port Obligatoire Du Casque Et Des Écouteurs
- Usar Casco De Protección



- Wear Breathing Protection
- Port obligatoire d'un masque respiratoire protecteur
- Usar Máscara De Protección



- The Use Of Ear Protection Is Mandatory
- Port obligatoire da casque antibruit
- Es Obligatorio El Uso De Protección Auditiva



- Wear a Hard Hat
- Port Obligatoire Da Casque Antibruit
- Usar Casco Duro



- Wear Safety Shoes
- Port obligatoire des chaussures de sécurité
- Usar Zapatos De Seguridad



- Wear Appropriate Clothing
- Port obligatoire de la tenue appropriée
- Usar Ropa Adecuada



- Remove The Blade Prior To Hoisting, Loading, Unloading And Transporting The Machine On Jobsite.
- Démontage Obligatoire Du Disque En Cas D'élingage, De Chargement, De Déchargement Et De Transport Sur Le Chantier.
- Desmontar El Disco Antes De Desplazar, Cargar, Descargar O Transportar La Máquina En La Obra.



- Motor Off
- Arrêt Du Moteur
- Parar El Motor



- Use In Well Ventilated Area
- A Utiliser Dans Un Endroit Bien Ventilé
- Usar En Una Área Bien Ventilada



- Do Not Use In Flammable Areas
- Ne Pas Utiliser Dans Des Ambiances Comportant Un Risque D'incendie
- No Usar In Áreas Inflamables



- Machinery Hazard, Keep Hands And Feet Clear.
- Danger! Rester À Distance De La Machine
- Máquina Peligrosa - Mantenga Manos Y Pies Alejados De La Máquina



- No Non-working Personnel In Area
- Zone Interdite Au Personnel Non-Ouvrier
- Prohibido Para Personas Ajenas A La Obra



- No Smoking
- Défense De Fumer
- No Fumar



- Do Not Operate Without All Guards In Place
- Ne Pas Utiliser Avant D'avoir Installé Toutes Les Protections
- No Operar Sin Todas Las Protecciones In Su Sitio



- Always Keep the Blade Guards In Place
- Toujours Vérifier Que Les Protections De Disque Sont Bien En Place
- Mantenga Siempre Las Protecciones De La Hoja En Su Sitio



- Keep Work Area Clean/Well Lit, Remove All Safety Hazards
- La Zone De Travail Doit Toujours Être Propre, Bien Éclairée Et Ne Présenter Aucun Risque
- Mantenga Limpio El Sitio De Trabajo/Bien Iluminado, Elimine Todos Los Riesgos De Seguridad



- Dangerously High Noise Level
- Niveau De Bruit Dangereux
- Nivel De Ruido Elevadamente Peligroso



- Pay Extreme Attention To The Care And Protection Of The Machine Before Starting Up
- Accorder Une Très Grande Attention À La Sécurité Et À La Préparation De La Machine Avant De Commencer À Travailler
- Ponga Extrema Atención Al Cuidado Y Preparación De La Máquina Antes De Ponerla En Marcha



- Remove Tools From Area and Machine
- Enlever Les Outils De La Zone De Travail Et De La Machine
- Elimine Las Herramientas Del Área Y De La Máquina



- Electrical Switch - OFF
- Interrupteur électrique-arrêt
- Conmutador De Apagado Eléctrico



- Electrical Switch - ON
- Interrupteur électrique-marche
- Conmutador De Encendido Eléctrico



- Electrical Switch - Start
- Interrupteur électrique-démarrage
- Conmutador De Arranque Eléctrico



- Repairs Are To Be Done By An Authorized Dealer Only
- Les réparations ne peuvent être exécutées que par un distributeur agréé
- Las Reparaciones Deben Ser Efectuadas Únicamente Por Un Distribuidor Autorizado



- Diamond Blade
- Disque diamanté
- Sierra Diamantada

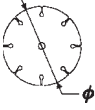

- Blade Diameter
- Diamètre De Disque
- Diámetro De La Hoja

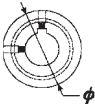

- Pulley Diameter
- Diamètre De Poulie
- Diámetro De La Correa



- Number of Revolutions Per Minute, Rotational Speed
- Nombre De Tours/Minutes, Vitesse De Rotation
- N° De Revoluciones Por Minuto, Velocidad De Rotación



- Blade Flange Diameter
- Diamètre Du Flaque De Disque
- Diámetro De La Brida De La Hoja



- Blade Cutting Depth
- Profondeur De Coupe Du Disque
- Profundidad De Corte De La Hoja

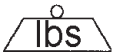

- Machine Mass (lbs)
- Poids De La Machine (en lbs)
- Masa De La Máquina (lbs)



- Electric Motor
- Moteur Électrique
- Motor eléctrico

## WARNING

### HEARING HAZARD

DURING NORMAL USE OF THIS MACHINE, OPERATOR MAY BE EXPOSED TO A NOISE LEVEL EQUAL OR SUPERIOR TO **85 dB (A)**

## ATTENZIONE!!!

RISCHIO DE LESIONE ALL'APPARATO Uditivo  
NELLE NORMALI CONDIZIONI DI UTILIZZO,  
QUESTA MACCHINA PUÒ COMPORTARE PER L'OPERATORE ADDETTO UN ESPOSIZIONE  
ACUSTICA DI LIVELLO PARI O SUPERIORE A

**85 dB (A)**

## ATENCION

### RIESGO DE DAÑO AUDITIVO

EN CONDICIONES NORMALES DE UTILIZACIÓN, EL OPERADOR DE ESTA MÁQUINA PUEDE  
ESTAR EXPUESTO A UN NIVEL DE RUIDO IGUAL O SUPERIOR A **85 dB (A)**



## DUST WARNING

**Cutting, especially when DRY cutting, generates dust that comes from the material being cut, which frequently contains silica.** Silica is a basic component of sand, quartz, brick clay, granite and numerous other minerals and rocks. Exposure to excessive amount of such dust can cause:

- Respiratory diseases (affecting your ability to breath), including chronic bronchitis, silicosis and pulmonary fibrosis from exposure to silica. These diseases may be fatal;
- Skin irritation and rash; and
- Cancer according to NTP\* and IARC\*  
\* National Toxicology Program, International Agency for Research on Cancer

Take precautionary steps

- Avoid inhalation of and skin contact with dust, mist and fumes;
- Wet cut when feasible, to minimize dust;
- Wear and ensure that all bystanders wear appropriate respiratory protection such as dust masks designed to filter out microscopic particles. (See OSHA 29 CFR Part 1910.1200)

### California Prop 65 Warning:

Use of this product can cause exposure to materials known to the State of California to cause cancer and/or birth defects or other reproductive harm.

## DECALS & LOCATIONS ETIQUETAS Y SU UBICACIÓN AUTOCOLLANTS ET LEURS EMPLACEMENTS



542 18 70-43\*  
Location: Top of Belt Guard



542 04 63-26\*  
Location: Motor Assembly



542 18 92-47\*  
Location: Elec. Motor

# DECALS & LOCATIONS ETIQUETAS Y SU UBICACIÓN AUTOCOLLANTS ET LEURS EMPLACEMENTS



**TARGET TILEMATIC TS250X**

542 19 07-41 (x2)

Location: Both Sides of Pan



504 04 02-01 (x2)

Location: Front Top Corner of Blade Guard



542 19 07-36

Location: Rear Handle



542 19 07-39

Location: Front of Pan

**GOOD MOTOR PERFORMANCE DEPENDS ON PROPER VOLTAGE. EXTENSION CORDS THAT ARE TOO LONG AND/OR SMALL REDUCE VOLTAGE TO MOTOR UNDER LOAD. USE EXTENSION CORDS NO SMALLER THAN INDICATED BELOW.**

MOTOR HP	50' CORD		75' CORD		100' CORD	
	115V	230V	115V	230V	115V	230V
1	#12	#14	#10	#14	# 8	#14
1 ½	#10	#14	#10	#14	# 8	#14
2	#10	#12	# 8	#12	# 8	#12
3	# 8	#10	# 8	#10	# 8	#10
5		# 8		# 8		# 8

046327

542 04 63-27\*

Location: Motor Assembly

## NOTICE

LOCATION FOR  
DRAIN HOLE OF  
WATER PAN TO  
BE AT THIS END

P/N 193794

542 19 37-94

Location: On Drain Plug End of  
Frame



# SAFETY FIRST!



**WARNING: FAILURE TO COMPLY WITH THESE WARNINGS AND OPERATING INSTRUCTIONS COULD RESULT IN DEATH OR SERIOUS BODILY INJURY.**

## DO

- DO read this entire operator's manual before operating this machine. Understand all warnings, instructions, and controls.
- DO keep all guards in place and in good condition.
- DO wear safety approved hearing, eye, head and respiratory protection.
- DO read and understand all warnings and instructions on the machine.
- DO read and understand the symbol definitions contained in this manual.
- DO keep all parts of your body away from the blade and all other moving parts.
- DO know how to stop the machine quickly in case of emergency.
- DO turn the "ON/OFF" switch to the "OFF" position prior to connecting the machine to the power source.
- DO inspect the blade, flanges and shafts for damage before installing the blade.
- DO use the blade flange size shown for each blade size.
- DO use only the blade flanges supplied with the saw. Never use damaged or worn blade flanges.
- DO use only blades marked with a maximum operating speed greater than the blade shaft speed. Verify speed by checking blade shaft rpm and pulley diameters and blade flange diameters.
- DO verify saw drive configuration by checking blade shaft RPM, pulley diameters, and blade flange diameter.
- DO read all safety materials and instructions that accompany any blade used with this machine.
- DO inspect each blade carefully before using it. If there are any signs of damage or unusual wear, **DO NOT USE THE BLADE.**
- DO mount the blade solidly and firmly. Wrench tighten the arbor nut.
- DO make sure the blade and flanges are clean and free of dirt and debris before mounting the blade on the saw.
- DO use the correct blade for the type of work being done. Check with blade manufacturer if you do not know if blade is correct.
- DO use caution and follow the instructions when loading and unloading the machine.
- DO operate this machine only in well ventilated areas.
- DO instruct bystanders on where to stand while the machine is in operation.
- DO establish a training program for all operators of this machine.
- DO clear the work area of unnecessary people. Never allow anyone to stand in front of or behind the blade while the motor is running.
- DO make sure the blade is not contacting anything before starting the motor.
- DO use caution when lifting and transporting this machine.
- DO always tie down the machine when transporting.
- DO use caution and follow instructions when setting up or transporting the machine.
- DO have all service performed by competent service personnel.
- DO make sure electric powered machines are plugged into a properly grounded circuit.
- DO make sure power cords are the proper size and in good condition.
- DO maintain a secure grip on the material being cut.
- DO clean the water tray frequently.
- DO verify the blade arbor hole matches the machine spindle before mounting the blade.
- DO clean the machine after each day's use.
- DO follow all electrical codes in your area.
- DO consider work area environment. Don't expose power tools to rain. Don't use power tools in wet locations.
- DO use caution to guard against electric shock. Prevent body contact with grounded surfaces (i.e., pipes, radiators, ranges, refrigerators).
- DO use correct voltage and proper extension cords. Never carry tool by cord or yank it to disconnect it from receptacle. Keep cord away from heat, oil and sharp edges.
- DO always carry the machine with the motor stopped.
- DO disconnect tools from power source when not in use, before servicing and when changing accessories.
- DO carefully maintain and clean for better and safer performance. Follow instructions for changing accessories. Inspect tool cords periodically and, if damaged, have repaired by authorized service facility.
- DO only cut in a straight line.
- DO only saw as deep as the job specifications require.
- DO always give a copy of this manual to the equipment user. If you need extra copies, call TOLL FREE 1-800-288-5040.

# SAFETY FIRST!



**WARNING: FAILURE TO COMPLY WITH THESE WARNINGS AND OPERATING INSTRUCTIONS COULD RESULT IN DEATH OR SERIOUS BODILY INJURY.**

## DO NOT

- DO NOT** operate this machine unless you have read and understood this operator's manual.
- DO NOT** operate this machine without the blade guard, or other protective guards in place.
- DO NOT** stand behind or in front of the blade path while the motor is running.
- DO NOT** leave this machine unattended while the motor is running.
- DO NOT** operate this machine when you are tired or fatigued.
- DO NOT** use a wet blade without adequate water supply to the blade.
- DO NOT** exceed maximum blade speed shown for each blade size. Excessive speed could result in blade breakage.
- DO NOT** operate the machine if you are uncertain of how to run the machine.
- DO NOT** use damaged equipment or blades.
- DO NOT** touch or try to stop a moving blade with your hand.
- DO NOT** cock, jam, wedge or twist the blade in a cut.
- DO NOT** transport a cutting machine with the blade mounted on the machine.
- DO NOT** use a blade that has been dropped or damaged.
- DO NOT** use carbide tipped blades.
- DO NOT** use abrasive blades.
- DO NOT** use conventional abrasive blades with water.
- DO NOT** touch a dry cutting diamond blade immediately after use. These blades require several minutes to cool after each cut.
- DO NOT** use damaged or worn blade flanges.
- DO NOT** allow other persons to be near the machine when starting or when the machine is in operation.
- DO NOT** operate this machine in an enclosed area unless it is properly vented.
- DO NOT** operate this machine in the vicinity of anything that is flammable. Sparks could cause a fire or an explosion.
- DO NOT** allow blade exposure from the guard to be more than 180 degrees.
- DO NOT** operate this machine with the belt guard or blade guard removed.
- DO NOT** operate this machine unless you are specifically trained to do so.
- DO NOT** use a blade that has been over heated (Core has a bluish color).
- DO NOT** jam material into the blade.
- DO NOT** grind on the side of the blade.
- DO NOT** lay power cords in or near the water.
- DO NOT** replace the motor with any motor that does not have a special grounding connection.
- DO NOT** cut deeper than 1" per pass with a dry blade. Step out to achieve deeper cuts.
- DO NOT** start cutting with a saw until you have a clear work area and secure footing.
- DO NOT** operate this machine while using drugs or alcohol.

\*\*\*\*\*

This saw was designed for certain applications only. **DO NOT** modify this saw or use for any application other than for which it was designed. If you have any questions relative to its application, **DO NOT** use the saw until you have written Husqvarna Construction Products and we have advised you.

**FIGURE 1**

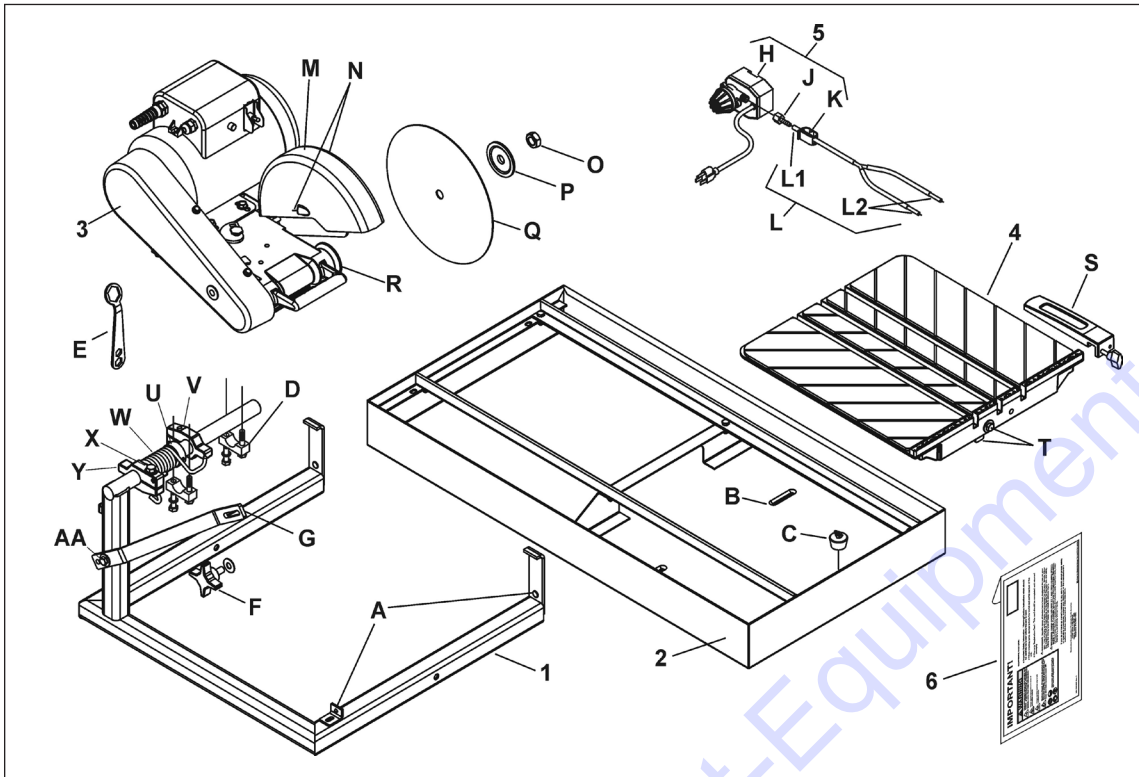

**Assembly Component Identification**

**Major Assemblies in Shipping Carton**

- A. Pan Guides
- B. Pan Stops
- C. Drain Plug
- D. Bearing Cap & Fasteners
- E. Tile Saw Wrench (15/16" x 9/16" x 1/2")
- F. Locking Knob
- G. Lockbar
- H. Water Pump
- J. Hose Barb Fitting
- K. Water Valve
- L. Water Tube Assy
- L1. Fitting End - Tube Assy
- L2. Plastic Nozzles - Tube Assy
- M. Blade Guard
- N. Ports - Water Tube Nozzle
- O. Arbor Nut
- P. Blade Flange - Outer
- Q. Blade
- R. Blade Flange - Inner
- S. Rip Fence
- T. Cart Stop
- U. Set Collar
- V. Adjustable Position Limiter
- W. Torsion Spring (W1 & W2)
- X. Capscrew - Tension Adjuster
- Y. Tension Adjuster
- Z. Roll Pin - Tension Adjuster
- AA. Capscrew - Lockbar Adjustment

- 1. Cutting Head Assembly: Includes Water Tube Assembly (L)}
- 2. Frame Assembly
- 3. Water Pan Assembly
- 4. Conveyor Cart Assembly (4) with Rip Fence (S) included.
- 5. Water Pump and Accessory Carton: Includes Water Pump (H), Hose Barb (J), Water Valve (K), 15/16"-9/16"-1/2" Wrench (E), Drain Plug (C), Locking Knob (F) with 5/16" Flatwashers, Bearing Caps (D) w/ 5/16" Fasteners.
- 6. Literature Envelope - Important to open and read thoroughly.

**FIGURE 2**

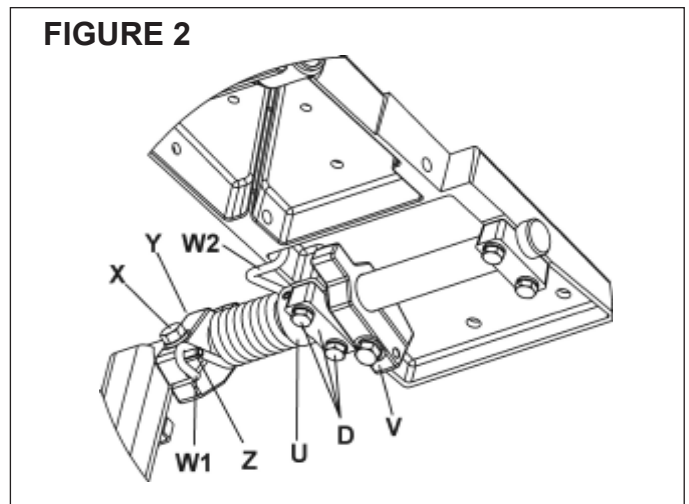



**INSTRUCTION  
INDICATION  
INFORMATION**



**WARNING**



**PROHIBITION**

These signs will give  
advice for your safety



Use only blades marked with a maximum operating speed greater than the blade shaft speed.



Before starting up the machine, make sure you read this entire manual and are familiar with the operation of this machine.



The working area must be completely clear, well lit and all safety hazards removed.

Before leaving our factory every machine is thoroughly tested.



Follow our instructions strictly and your machine will give you long service in normal operating conditions.

## 1 Features

**Use:** Sawing of any kind of tile, up to 24" (610mm).  
Diagonal on 16" x 16" (406 x 406mm) tile.

**Tools:** Rip Guide comes standard on all tile saws. See **Tile Cutting Accessories** on page 19.

(For information or availability of other accessories contact Discount-equipment.)

**Blade Capacity:** Rim Ø 10" (254mm) - bore 5/8" (15,9mm).

**Profile Wheel:** Rim Ø 6" (152mm) - bore 5/8" (15,9mm).

**Blade Rotation:** Counter-Clockwise (CCW).

**Depth of Cut:** 3-3/4" (95mm) with 10" (254mm) blade.

<b>Horsepower:</b>	1-1/2	1-1/2
<b>Voltage:</b>	115	115/230
<b>Hertz:</b>	60	60
<b>F.L. Amperages:</b>	14.6	17.2/8.6

<b>Blade Shaft RPM:</b>	2760	3880
<b>Weight: lb. (kg.)</b>	105 (48)	110 (50)
<b>Dimensions - L x W x H: in (mm)</b>	34-3/16" x 21-1/8" x 19-3/4" (861 x 537 x 502)	

**Conveyor Cart - L x W: in (mm)** 16-1/2" x 16" (419x406)

**Pan Holding Capacity:** 6.5 gallons (24.7 liters)

**Water Pump Output:** 100 gal/hr. (378 l /hr.) Standard  
300 gal/hr. (1135 l/hr.) Optional



The operator must wear protective clothing appropriate to the work he is doing.



Any persons not involved in the work should leave the area.

## 2 Benefits

- The new, improved blade guard offers simplified blade installation and removal - maximum 10" (254mm) blade capacity. The external water tube assembly (L) is removable for easy maintenance.
- 1-1/2 HP, High Torque (HT) 115V/60/1 motor on standard saw.
- The dependable, high volume, submersible coolant pump features a screened intake.
- The motor and pump power cords are securely mounted directly into the Motor Housing.
- The removable Drain Plug (C) at the back end of the pan permits easy coolant draining and quick sludge clean out. The Water Pan (2) is removable for easy cleaning.
- The free-rolling Conveyor Cart (4) is aligned for straight, smooth cuts. The Back stop with ruler allows fast mounting and adjustment of the Rip Fence (S) and optional accessories.
- Makes diagonal cuts on 16" x 16" (406 x 406 mm) tile. Can make 24" (610mm) rip cuts.
- Full-size belt shield and belt protection.
- The adjustable Water Pan (2) allows the operator to cut tile comfortably with a full view and control of work with minimum stretching.

## 3 Machine Set-Up

See Figure 1

- Remove all items from the shipping carton and identify:
  1. Cutting Head Assembly (3) including Water Tube Assembly (L)
  2. Frame Assembly (1) with Lockbar (G) & Spring-assisted Plunge Assembly.
  3. Water Pan Assembly (2)
  4. Conveyor Cart Assembly (4) and Rip Fence (S)
  5. Water Pump and Accessory Carton: Includes Water Pump (H), Hose Barb (J), Water Valve (K), 15/16" Wrench (E), Drain Plug (C), Locking Knob (F) with 5/16" flatwasher, Bearing Caps (D) with 5/16" Capscrews & Flatwashers.
  6. Literature Assembly Envelope

**NOTE:** Check the carton and all packing filler for loose parts and optional accessories (if ordered).

**IF ANY PARTS ARE MISSING OR DAMAGED, PLEASE CONTACT Discount-equipment FOR INSTRUCTIONS.**

**Tools required:** Your new saw can be completely assembled with the Wrench (E) provided.

Qty	Part Number	Description	Size
1	542 16 16-41	Wrench	15/16" x 9/16" x 1/2"

- Set the Frame Assembly (1) on a flat surface or on a **Husqvarna®** folding stand.
- Install the Water Pan Assembly (2) between the four Pan Guides (A) on the Frame Assembly (1). Locate the Pan (2) with the Drain Plug (B) at the operating end with the Pan Stops (C) located on the bottom of the Pan (2) straddling the front leg of the Frame (1). The Water Pan Assembly (2) should slide freely back and forth between the Guides (A) with little lateral movement. Adjust Guides if needed.

### **Install the Cutting Head Assembly (1):**

1. Set the Cutting Head Assembly (3) on the pivot bar up between the Set Collar (U) and the adjustable Cutting Head Position Limiter (V). See **Figures 2a & 2b**. These components have been pre-set at the factory to align the blade with the slot in the center of the cart; this is adjustable. See **Alignment Procedures**, section 8.
2. Using the 5/16" Capscrews and Lockwashers provided, install the two Bearing Caps (D) to the bottom of the Cutting Head (3). To secure the Cutting Head (3) to the pivot bar, tighten the Capscrews with a 1/2" wrench or use the Wrench (E). For plunge cutting, leave the Bearing Caps (D) free enough to allow the Cutting Head limited movement up or down.
3. Insert the Locking Knob (F) with 5/16" flatwasher through the slotted Lockbar (G) into the tapped hole in the belt guard. This is used to set the cutting depth of the blade. See section 5.

#### **Set-up with the Torsion Spring (W):**

With the Cutting Head installed on the pivot bar, rotate the Torsion Spring (W) until the inside spring loop (W1) engages around the lower edge of the motor platform. Loosen the 5/16" Capscrew (X) in the spring Tension Adjuster (Y) and move it to engage the Roll Pin (Z) into the outside spring loop (W2). Set the desired tension for your plunge cutting and tighten the Capscrew (X) to secure the Tension Adjuster to the pivot bar. Use the flats on the back of the Tension Adjuster with a adjustable wrench if extra tension is needed.

### **Water Pump Assembly (5) Set-up:**

1. Remove the Water Pump (H), Hose Barb (J), the Water Control Valve (K) and Water Tube Assembly (L) from their carton. Thread the Hose Barb

- (J) on the water pump outlet, hand tighten.
2. Slide the Control Valve (K) onto the flexible plastic tubing and push the open end onto the Hose Barb (J).
3. Set the Water Pump Assembly (5) in the deep end of the pan beneath the belt guard. **Note: The water pump inlet screen must be submerged in order to properly pick up water.**
4. Place the Water Tube Assembly (L) to the back of the Blade Guard (M) and insert the two 1/4" plastic nozzles (L2) into the two water Ports (N) on the side of Blade Guard (M). Route water tubing so as to prevent interference with the full movement of the Cart (4).
5. Insert the male plug into the dedicated receptacle on the motor. The Water Pump (H) will start when the motor is turned on. For dry cutting, the water pump should be unplugged or removed to prevent damage to the pump.

**NOTE: THE MOTOR WATER PUMP OUTLET IS NOT TO BE USED AS A GENERAL PURPOSE CONVENIENCE OUTLET. USE FOR CONNECTION OF THE SUPPLIED WATER PUMP ONLY.**

### **WATER PUMP SAFETY GUIDELINES**



**Always plug the saw power cord into a GFCI outlet when using. If a GFCI type outlet is not available, use a plug-in type GFCI plugged into a properly grounded outlet. Do not use any temporary plug adapters.**

- The water pump is equipped with a ground electrical plug, to reduce the risk of possible shock. Be sure to connect to a properly grounded type receptacle.
- Never pick the water pump up out of the water when it is plugged in.
- **DO NOT EVER** use the water pump to pump anything but water.
- Never service the pump when it is still plugged in.
- Never let the pump operate dry. It is self-cooled by pumping water. Dry use will cause the pump to fail.
- Maintain regularly and clean out debris from intake screen.
- Check the power cord for nicks or frays and never try to alter the power cord in any way.

### **Installation & Removal of Cutting Blade:**



**Always set the Motor Switch to OFF prior to mounting the blade.**

Be sure you are using the correct blade for the material being cut. For example, blades are available for cutting materials such as wall tile, quarry tile, marble, slate and similarly hard materials. For the best results, always use genuine **Husqvarna®** diamond blades. Contact Discount-equipment to select the correct blade for your specific cutting needs.

1. Raise the Blade Guard (M) to fully up and tighten the wing nut on the side to hold it in the raised position.
2. Remove the Arbor Nut (O) and the Outer Blade Flange (P). Use Blade Shaft Lock if needed. See **Using the Bladeshaft Lock**.
3. Check the Blade (Q) for Counter Clockwise rotation (CCW) and install on the spindle shaft against the Inner Blade Flange (R).



Rotation direction is indicated by an arrow on one side of the blade. Make sure the blade contact surfaces are clean, free of debris.



Do not over-tighten Bladeshaft Nut. Do not use Bladeshaft Lock to tighten Arbor Nut.

5. Install the Outer Flange (P) putting the large surface against the Blade (Q). Hand tighten the Arbor Nut (O) with the 15/16" Wrench (E) provided. Do not over-tighten, Hand tight is sufficient.
6. Lower the Blade Guard (M) and retighten the wing nut to securely hold the guard in place.

### Using the Bladeshaft Lock

An easy-to-use Bladeshaft Lock system can be used to loosen the Arbor Nut (O). With one hand, push the Bladeshaft lock Lever back toward the Motor while rotating the Arbor Nut Counter Clockwise (CCW) with the 15/16" wrench until the Lock engages the Bladeshaft. The Lock will then stay engaged, preventing the Bladeshaft from turning while the Arbor Nut is removed. The Lock will spring-return to the unlocked position when Lever and Bladeshaft are released.

- Install the Drain Plug (B) into the drain hole in pan and fill the Pan with clean water until inlet filter of water pump is covered. See **Features** for capacity.
- Adjust the Pan Assembly (2) to accommodate the size of the tile to be cut and to obtain the most comfortable position for the operator.
  1. When cutting smaller tile units, adjust the pan all the way to the rear. The operator has full view and control of the work with minimum stretching.
  2. For cutting intermediate sized units, such as 8" or 10" tile, the pan can be placed somewhere between the maximum forward and maximum rear positions.
  3. When cutting larger units, the pan should be moved to the maximum forward position, thus giving the operator the best and most comfortable position, even when cutting 12" x 12" or larger units.
  4. When cutting smaller tile, adjust cart stop to limit cart travel. When cutting larger tile, adjust cart stop to allow for extended travel.

4

## OPERATING PROCEDURE



**WARNING:** Read the Operating Procedure completely before operating your tile saw.



Take into account the working conditions from the health and safety point of view.



Always pay extreme care and attention to the preparation of the machine before starting.



Remove all wrenches and tools from the machine.



Always keeps blade guard in place.

- Fill the Pan (2) with enough water to fully submerge the water pump screen.
- Before connecting the power cord:
  - \* Check that the Blade Shaft Nut (O) is secure and that the Blade (Q) rotates freely.

**WARNING:** Check that the ON/OFF switch is in the OFF position. Then connect the power cord to a properly grounded outlet of the correct voltage. See the decal near the power cord for power requirements. If needed, use the correct size three (3) conductor extension cord to avoid excessive voltage drop. Never use lamp cord type extensions. Refer to the **Recommended Extension Cords**, Section 7.



- Turn the switch to **ON**. The blade is to turn counter-clockwise, when looking at the blade guard side. The water pump starts automatically with the motor. Adjust the water supply with the Control Valve (K).
- Follow the blade manufacturer's recommendations for wet or dry cutting. Wet cutting blades can be damaged or destroyed without sufficient water. Only blades specifically designed for dry cutting can be used without coolant.



**The water supply should be adequate, with water flowing on both sides of the blade. Keep the water clean and make certain the WATER LEVER IS ALWAYS ABOVE THE PUMP INLET. Do not run the water pump dry!! Unplug for dry cutting.**

- For straight cuts, position the tile squarely against the back edge of the conveyor cart. Keep the cart clean and free of cuttings. The standard Rip Fence (S) is supplied for setting cutting lengths.
- Move the conveyor cart slowly and carefully until the blade is in contact with the tile. For best cutting, a new blade needs a chance to "break-in" or "wear-in" slightly. It may take several cuts to open (expose diamonds) of a new blade.

## 5 ADJUSTABLE LOCKBAR WITH DEPTH LINKING PROTECTION

FIGURE 3

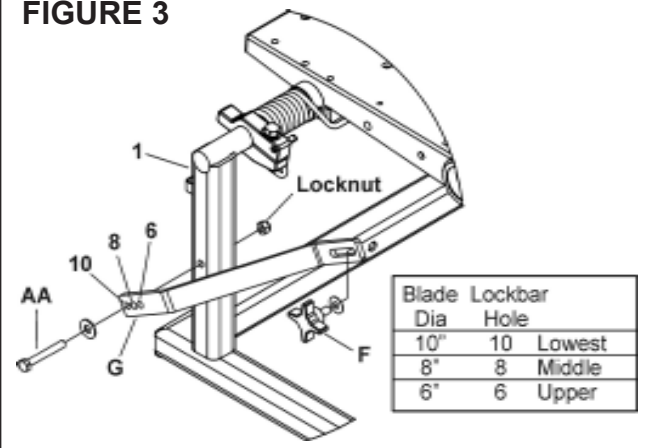

A Lockbar (G) is used to set the blade depth during cutting. The lockbar has three (3) holes at the lower end for use with 10", 8" and 6" blades. Refer to chart in Figure 3. These are used as depth-limiting settings that, if used with the correct blade diameter, will protect the rolling cart from being cut by the blade.

The tilesaw is shipped standard set-up for a 10" diameter blade. To change the setting, locate the capscrew (AA) used as the pivot, loosen and remove the Lock Nut. Set the Lockbar (G) at the proper hole for blade size. Tighten the 5/16" fasteners so that the Lockbar (G) is snug but free to pivot. Check the setting by loosening the Knob (F) and lowering the head fully down into the table slot. The blade segment should be below the table surface, but not cutting into the table. (See also Section 10, Plunge Cutting.)

## 6 MANUAL THERMAL OVERLOAD

The motor is equipped with a manual overload protection reset button. If the motors overheats, the red reset button will "pop out" to open the motor circuit; stopping the motor and water pump. If this occurs, the motor ON/OFF switch must be set to OFF. After the motor cools, push in the reset button. When it stays in, the motor can be restarted.

## 7 RECOMMENDED EXTENSION



Good motor performance depends on proper voltage. Extension cords that are too long and/or too small in wire gauge reduce the voltage to the motor under load. Use extension cords no smaller than indicated below.

MOTOR	F.L. AMPS	50' Cord		75' Cord		100' Cord			
		115V	230V	115V	230V	115V	230V		
1-1/2 HP	1725 RPM	14.6		#12		#10		#8	
1-1/2 HP	3450 RPM	17.2	8.6	#10	#14	#10	#14	#8	#14

## 8 ALIGNMENT PROCEDURES

Your tile saw is factory assembled and aligned prior to shipment to ensure accurate cuts when your saw is delivered. However, since Husqvarna® cannot control rough handling during shipping, it is suggested that the alignment be checked. If the saw is found in need of adjustment, refer to the appropriate section(s) below.

There are two basic alignment checks for the tilesaw and any adjustments made must follow these procedures to ensure that the unit functions freely.

Adjustment tools required: Carpenter's Square, two (2) 7/16" wrenches, 1/2" wrench, 9/16" wrench and 5/32" hex key.

### 1. Check the Blade in Slot Alignment

- \* The Blade (Q) should be centered in the middle slot of Conveyor Cart (4).
- \* Set-up your saw as described above and move the Conveyor Cart (4) back and forth from the front to the rear of the Pan (2). If the Blade (Q) contacts either side of the slot, the Cutting Head Location Adjustment must be performed.

### Cutting Head Adjustment (See Figure 1)

- \* The Cutting Head Assembly (3) is positioned with the Set Collar (U) against the left side of the Motor platform and the Head Position Limiter (V) against the inside.
- \* Loosen the Set Collar (5/32" hex key), the Position Limiter (9/16" wrench) and the four (4) fasteners (1/2" wrench) of the Bearing Cap (D).
- \* Move the Head Assembly (3) along the Pivot Bar of the Frame (1) until the Blade (Q) is centered in the center slot. Locate the Set Collar (U) against the outside of the Motor platform again and retighten the set screw. Locate the Head Position Limiter (V) against the inside wall of the Motor platform, adjust to limit the Cutting Head movement (See section 10) and tighten the 3/8"-16 Bolt.
- \* Check that the Blade is now in the center of the middle slot. Tighten the four (4) fasteners of the

### 2. Check the Parallel Alignment

- \* The Conveyor Cart (4) should travel parallel to the plane of the Blade (Q).
- \* Place a Square rule against the backstop of the Cart (4), lightly in contact with the Blade (Q). The blade surface should be parallel to the square; i.e., no gap between the blade and the square at either the front or back edge of the blade. Next, traverse the cart back and forth along the Rails. The blade should remain parallel to the square, staying slightly in contact with it throughout its full travel. It should not move away from the Blade nor should the Blade push the the Square away. If the either happens, the Blade (Q) will not cut straight and the Parallel Alignment must be performed.

### **Parallel Alignment for Sraight Cuts**

The Rails determine the path the tile on the Conveyor Cart (4) travels. For a straight cut, the Cart must then travel 'Parallel' to the plane (or side surface) of the Blade. The path of the Conveyor Cart (4) must then be modified by adjusting the Rails to agin be Parallel to the side of the Blade. Slotted mounting holes in both ends of the Water Pan (2) are provided to allow for this adjustment.

Tip: Align only one Rail first; usually the Inner Rail. After one Rail is aligned the other is easily aligned using the Cart (4) as a guide. If moving the one end of the Rail is not enough to provide complete alignment, the other end can be moved in the opposite direction to provide additional Rail movement.

- \* Slightly loosen all 1/4"-20 fasteners (7/16" wrenches) locating the two Rails so that both rails are free to move. Move one end of the Inner Rail until the square remains flush with the Blade while the cart is moved to and fro as described above in **Check Parallel Alignment**. Tighten the fasteners of this rail and recheck the alignment.
- \* Once alignment of one Rail has been made set the second Rail parallel to the first. Traverse the Cart (4) back and forth along the rails and use it as a guide to locate the second rail parallel to the first. Tighten the remaining 1/4"-20 fasteners and recheck the alignment.

## **9 PROFILE WHEEL SET-UP AND USE**

See Figure 1

The tilesaw is designed for use with a **Husqvarna® 6"** Profile Wheel, such as 542 62 10-81\* (3/8" Radius) or 542 62 10-82\* (1/2" Radius).

- Raise the blade guard. Remove the spindle nut and outer flange. Remove the tile saw blade if one has been installed. (Refer to Section 5, Adjustable Lockbar, if needed)
- Install the profile wheel onto the spindle shaft up against the inner flange with the working surface to the outside.
- Secure into place by reversing the outer flange and tightening the spindle nut. Lower the Blade Guard (M) back down over the profile wheel.
- Locate the material for profiling:
  1. Set the edge of the part to be shaped parallel to the wheel.
  2. Locate the material under the wheel. Pull the Conveyor Cart (4) with the material from under the wheel to set proper cutting height.
  3. Loosen the Locking Knob (F) and lower the Cutting Head (1) so that the wheel just slightly makes contact with the material.
  4. Secure the Cutting Head (1) into position with the Locking Knob (F) for cutting.

5. **Note:** Profiling usually takes several light passes to produce the best results. Set lower each time until the desire depth has been reached.

## **10 PLUNGE CUTTING**

See Figures 1 & 2

### **Spring Force Adjustment:**

Spring force can be adjusted by rotating Spring Tensioner (Y). Loosen the 3/8"-16 Bolt (X) and rotate Spring Tensioner (Y) to increase or decrease Spring Force. Tighten Bolt to secure Tensioner to Pivot Shaft. It may be necessary to slightly loosen the Bearing Caps (D) for proper and smooth operation. By loosening Knob (F), Pivot Head can be raised or lowered with minimal effort, depending on Spring Force adjustment.

### **Limiting Cutting Head Movement:**

An adjustable Head Position Limiter (V) is located on the underside of the Head platform and is used to locate the Blade in the center slot of the Cart and, along with the Lockbar, as a raise and lower Position limiter for the Cutting Head. See **Cutting Head Adjustment; section 8**.

## **11 MAINTENANCE PROCEDURES**



**Before performing any maintenance, ALWAYS place the machine on a level surface with the motor OFF and disconnect the electrical current. Let the machine cool down!!**

Your **Husqvarna®** tile saw is a ruggedly constructed machine, engineered to give long, satisfactory performance. Simple daily maintenance and care will add to the life and productivity of your saw. After each day's use: **CLEAN THE MACHINE!!**

- \* Turn off and unplug the saw before performing any maintenance.
- \* Keep the cart top clean and free for cuttings. To clean it, flush the top surface and grooves with water.
- \* Drain, clean and refill the pan frequently. Flush the coolant system with plenty of water, then drain and refill the pan.
- \* If the water flow stops, check the water pump to see if the shaft and impeller turn freely. See the **WATER PUMP TROUBLE-SHOOTING PROCEDURE** section.
- \* It is always good practice to clean your tile saw after each day's use. Drain the water and clean out the pan. Clean the rails. Before storing, it is good practice to wipe or spray rails with water-soluble oil (like, WD-40 or equivalent).



**Entrust all repairs to your authorized dealer only.**



## 12 WATER PUMP TROUBLE-SHOOTING PROCEDURE

### If Water Stops Flowing,

1. **Stop Sawing**, then
2. **Disconnect Electrical Plug from Outlet**, then
3. **Remove the Pump**, then
4. **Back Flush**.

Back flushing is done by forcing water into the pump discharge and out through the screen. Most of the time this procedure works, and the pump can be put back into service. (See Figure 4 below)

If the back flushing does not work, remove the screen and turn the impeller manually, looking for and rinsing out the impeller cavity of any dirt or foreign matter.

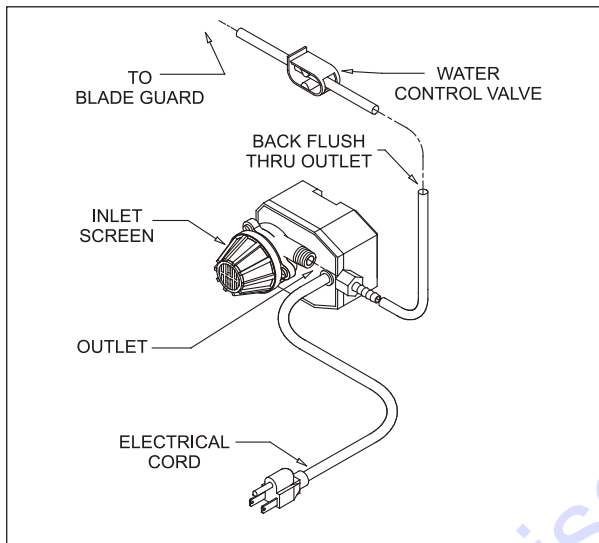

## 13 REPAIRS

We carry out all repairs in the shortest possible time and at the most economical prices. (See front page for address and phone numbers) Contact Discount-equipment concerning maintenance and re-

### **V-Belt Tensioning with Cam Adjustment:**



**Always set the Motor Switch to OFF and unplug power cord before making any repairs or adjustments to your saw.**

This tile saw is belt driven. The standard unit uses a 6 groove Poly-V Belt. The tension is factory set, but on occasion it may be necessary to adjust the belt especially if it is being replaced. **Again, adjust only with the saw turned off and unplugged.**

Tools needed: One 3/8" wrench, two 1/2" wrenches, one 3/8" Drive Extension x 8" or longer, and a 12" Straight Edge.

1. Remove the Belt Guard to get access to the V-Belt.
  - a. Remove two 1/4"-20 Flange Bolts (3/8" wrench) on top of Belt Guard.
  - b. Remove 5/16"-18 Bolt and Locknut (two 1/2" wrenches) on side flange of Belt Guard.
2. Loosen the four 5/16"-18 Flange Bolts (1/2" wrench) that hold the Motor to the platform.
3. Remove the Belt Guard for full access to belt and pulleys.
  - a. Remove the two 1/4"-20 Flange Bolts (3/8" wrench) from top of Guard.
  - b. Remove the 5/16"-18 fasteners (two 1/2" wrenches) from the side of Belt Guard.
4. Rotate the belt tensioning Cam (1/2" Drive Extension) to tighten the belt(s) to proper tension.
  - a. With belt tensioned, use the 12" Straight Edge to check for correct pulley alignment and tighten the engine mounting screws.
  - b. Replace the Belt Guard before operating the tile saw. Always replace any guarding before start-

## 14 SPARE PARTS

For quick supply of spare parts and to avoid any lost time, it is essential to quote the data on the manufacturers plate fixed to the machine and the part number(s) and description to be replaced with every order.

## 15 TILE CUTTING ACCESSORIES

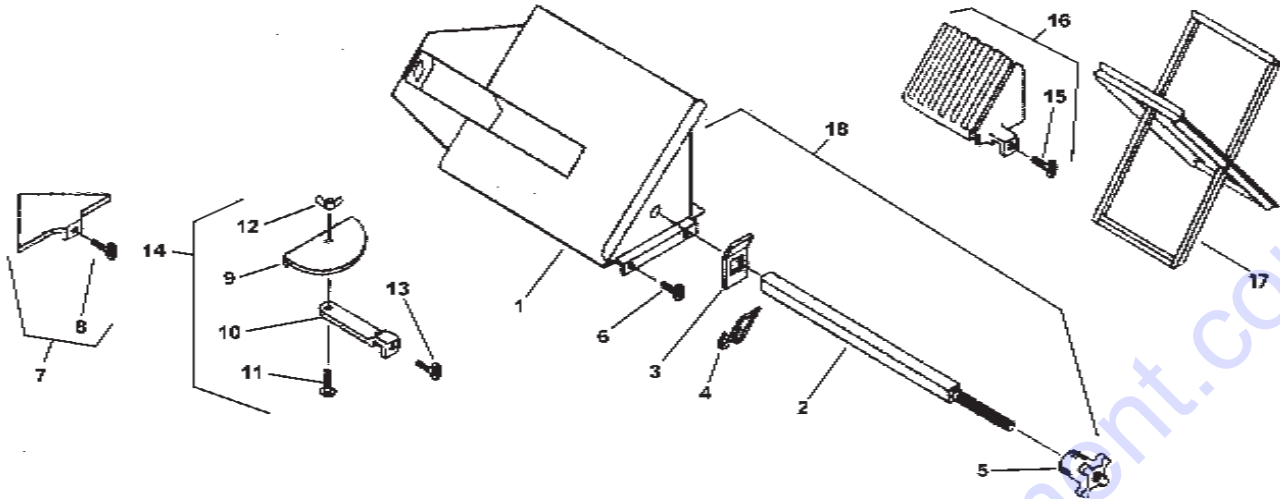

ANGLE GUIDE	PROTRACTOR	MIGHTY MITER GUIDE	BULLNOSE	FOLDING STAND
542 05 10-20*	542 05 10-10*	542 16 14-80*	542 05 10-30*	542 20 32-52*

### Parts List:

Diag.	Part No.	Qty.	Description	Diag.	Part No.	Qty.	Description
1	542 05 01-04*	1	Frame, Miter	10	N/A	1	Arm, Protractor
2	542 05 01-07*	1	Bar, Locking	11	542 02 00-11*	1	Carriage Bolt, 1/4"-20 x 5/8"
3	542 05 01-05*	1	Clip, Stop	12	542 02 02-44*	1	Wing Nut, 1/4"-20 x 1"
4	542 05 01-06*	1	Spring	13	542 18 97-37*	1	Knob, 1/4"-20 x 1"
5	542 05 01-03*	1	Knob	14	542 05 10-10*	1	Protractor Assy
6	542 18 97-37*	2	Knob, 1/4"-20 x 1"	15	542 02 05-98*	1	Screw, Thumb, 1/4"-20 x 1"
7	542 05 10-20*	1	Miter Assy, 45°	16	542 05 10-30*	1	Holder Assy, Bullnose
8	542 18 97-37*	1	Knob, 1/4"-20 x 1"	17	542 20 32-52*	1	Stand, Tile Saw (for TS250X only)
9	N/A	1	Sector Plate	18	542 05 01-02*	1	Support Assy, Miter Frame

**RIP FENCE:** 542 05 10-00\* - The Rip Fence is a standard accessory supplied with every tile saw. It is used to provide a repeatable position for rip cuts until relocated. The Rip Guide clamps to the machined backstop of the conveyor cart.

**ADJUSTABLE PROTRACTOR:** 542 05 10-10\* - The Protractor can be used to rip cut known angles. The protractor clamps to the backstop.

**DUAL 45 ANGLE GUIDE:** 542 05 10-20\* - This is a non-adjustable miter used to quickly position the tile at 45 degrees; either on the left or right side. It is often used for repeated diagonal rip cuts. The Angle Guide clamps to the backstop.

**BULLNOSE MITER GUIDE:** 542 05 10-30\* - This is a fixed guide that positions the tile for a 45 degree miter cut. The Mitring Guide clamps to the backstop.

**MIGHTY MITER GUIDE:** 542 05 01-02\* - This is a 45 degree fixture that has an adjustable clamp to hold the tile while miter cutting. The Mitring Guide clamps to the backstop.

**FOLDING STAND:** 542 20 32-52\* - This stable stand brings a Husqvarna® tile saw to standing level for ease of work. The stand conveniently folds flat for storage and transporting.

**ADJUSTABLE ROLLING STAND:** 542 20 32-53 - This flexible-use stand can be adjusted from 29" to 33" in height. It has standard rear wheels for easy transportation. When stand is collapsed, the front legs become handles to wheel saw to and from jobsite. Springs assist the raising and lowering of the saw. Additional wheels are available to make rolling collapsed saw / stand onto truck easier.

**CART EXTENSION:** 542 20 30-37 - Fastens to front edge of 16-1/2" L x 16" W Conveyor Cart (542 20 30-83). Adds 5-1/4" to length to help support larger tile.

*The instructions for use and spare parts found in this document are for information only and are not binding. As part of our product quality improvement policy, we reserve the right to make any and all technical modifications without prior notice.*



**The manufacturer accepts no responsibility caused by unsuitable use or modifications.**

# Diagram 1: Wiring Diagram 542 20 30-79, 1.5HP, 115V/60/1

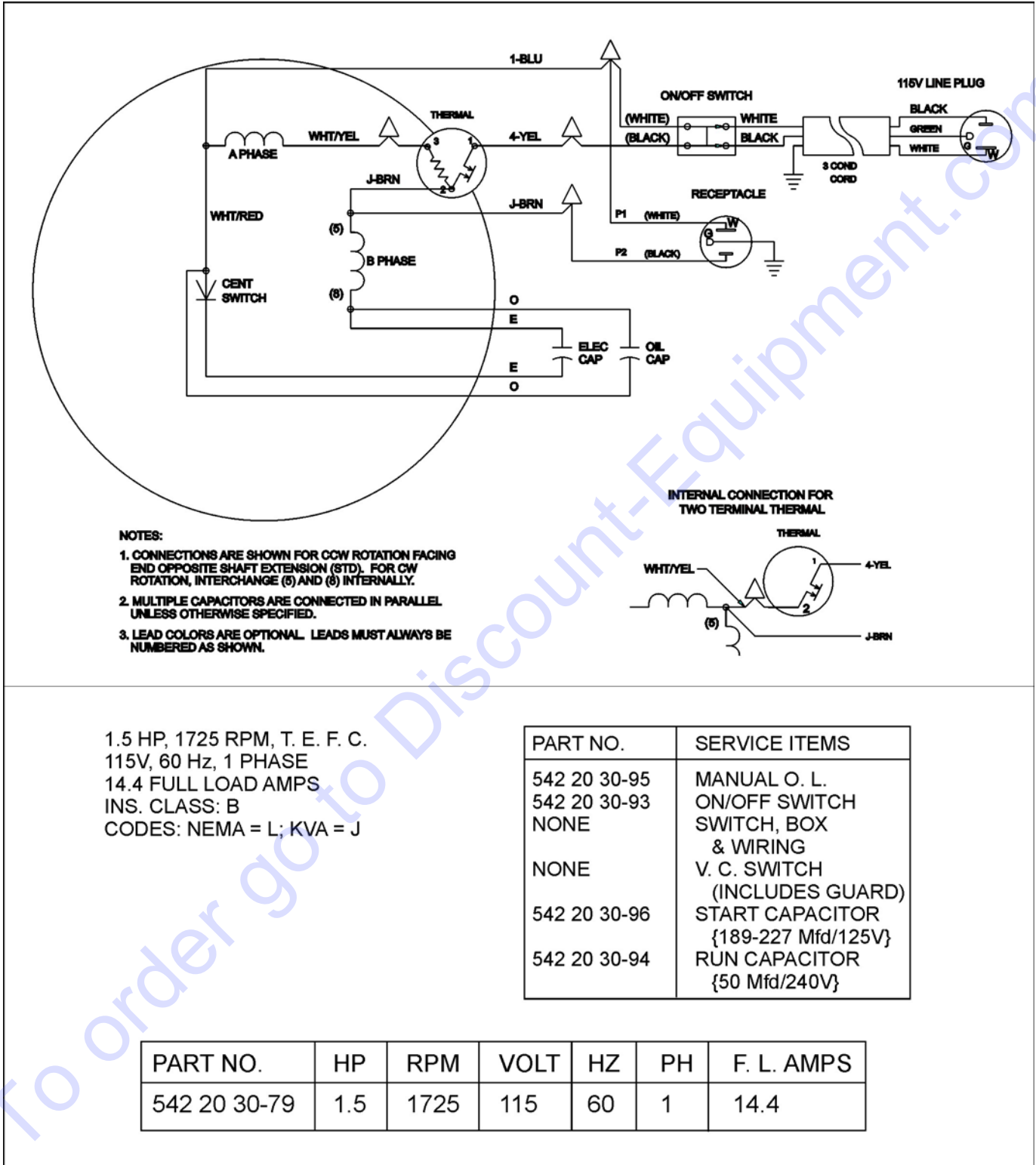

**Diagram 2: Wiring Diagram 542 00 06-05, 1.5 HP, 115V/208-230/60/1**

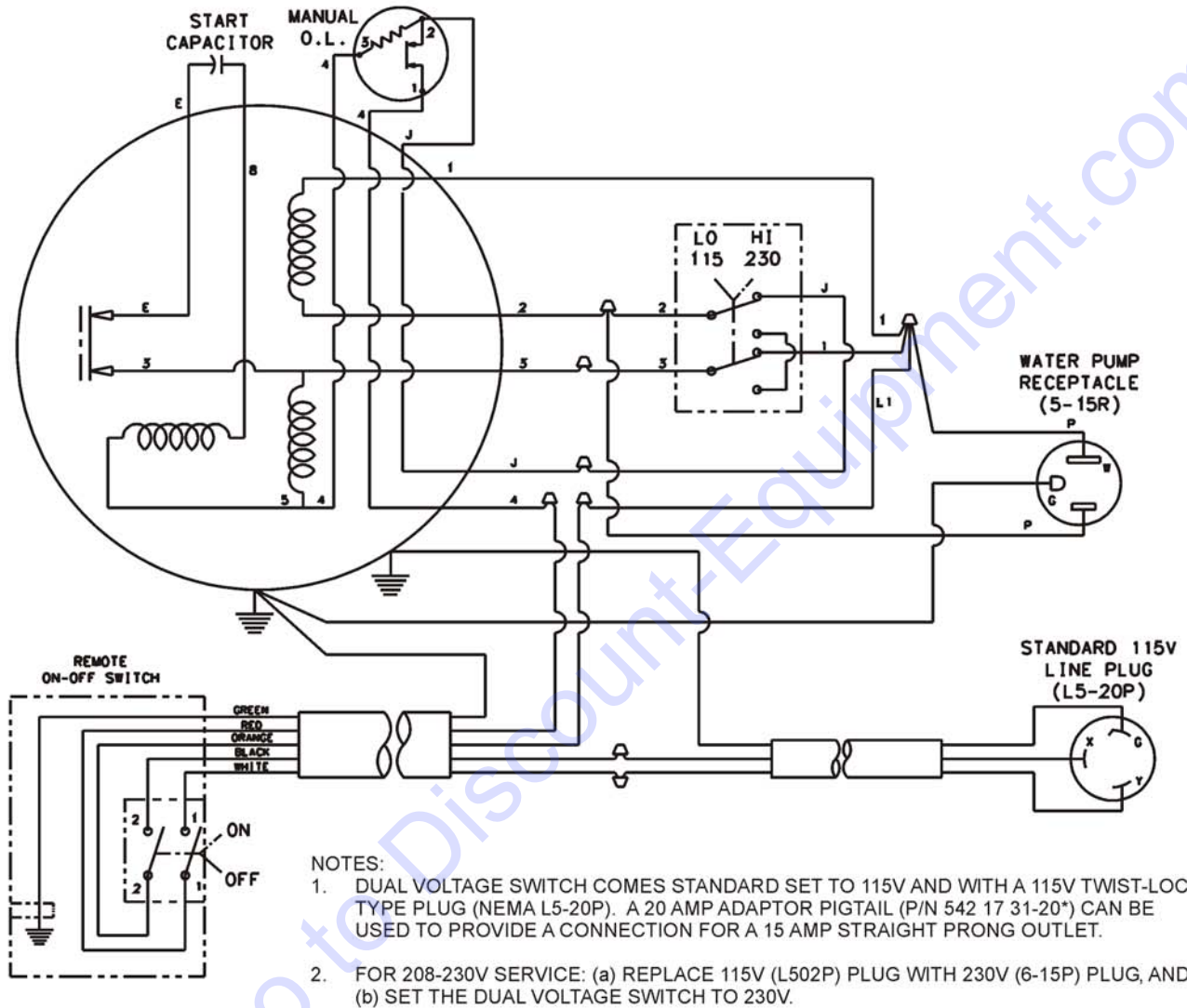

1.5 HP, 3450 RPM, T. E. F. C.  
 115V/208-230, 60 Hz, 1 PHASE  
 17.2/9-8.6 FULL LOAD AMPS  
 INS. CLASS: F  
 CODES: NEMA = -; KVA = J

PART NO.	SERVICE ITEMS
542 00 08-73*	MANUAL O. L.
542 16 15-81*	ON/OFF SWITCH
542 03 20-80*	SWITCH, BOX & WIRING
542 03 01-41*	V. C. SWITCH (INCLUDES GUARD)
542 18 91-17*	START CAPACITOR {460 Mfd/115V}
NONE	RUN CAPACITOR

PART NO.	HP	RPM	VOLT	HZ	PH	F. L. AMPS
542 00 06-05	1.5	3450	115/208-230	60	1	17.2/9-8.6

To order go to [Discount-Equipment.com](http://Discount-Equipment.com)



542 20 10-99

**TO PURCHASE THIS PRODUCT PLEASE CONTACT US**



**Equipment Financing and  
Extended Warranties Available**



**Discount-Equipment.com is your online resource for  
commercial and industrial quality parts and equipment sales.**

**561-964-4949**

**visit us on line @ [www.discount-equipment.com](http://www.discount-equipment.com)**

Select an option below to find your Equipment

**Search by Manufacturer**

**Search by Product Type**

**Request a Quote**

We sell worldwide for the brands: Genie, Terex, JLG, MultiQuip, Mikasa, Essick, Whiteman, Mayco, Toro Stone, Diamond Products, Generac Magnum, Airman, Haulotte, Barreto, Power Blanket, Nifty Lift, Atlas Copco, Chicago Pneumatic, Allmand, Miller Curber, Skyjack, Lull, Skytrak, Tsurumi, Husquvarna Target, Stow, Wacker, Sakai, Mi-T-M, Sullair, Basic, Dynapac, MBW, Weber, Bartell, Bennar Newman, Haulotte, Ditch Runner, Menegotti, Morrison, Contec, Buddy, Crown, Edco, Wyco, Bomag, Laymor, EZ Trench, Bil-Jax, F.S. Curtis, Gehl Pavers, Heli, Honda, ICS/PowerGrit, IHI, Partner, Imer, Clipper, MMD, Koshin, Rice, CH&E, General Equipment, Amida, Coleman, NAC, Gradall, Square Shooter, Kent, Stanley, Tamco, Toku, Hatz, Kohler, Robin, Wisconsin, Northrock, Oztec, Toker TK, Rol-Air, APT, Wylie, Ingersoll Rand / Doosan, Innovatech, Con X, Ammann, Mecalac, Makinex, Smith Surface Prep, Small Line, Wanco, Yanmar