



SPARE PARTS LIST

SURFACE PREPARATION EQUIPMENT

PG 450, 2018-02

Go to Discount-Equipment.com to order your parts



PARTS FINDER

**Search Website
by Part Number**



**Search Manual
Library For Parts
Manual & Lookup Part
Numbers – Purchase
or Request Quote**

**Can't Find Part or
Manual? Request Help
by Manufacturer,
Model & Description**

Discount-Equipment.com is your online resource for quality parts & equipment.

Florida: [561-964-4949](tel:561-964-4949) Outside Florida TOLL FREE: [877-690-3101](tel:877-690-3101)

Need parts?

Click on this link: <http://www.discount-equipment.com/category/5443-parts/> and choose one of the options to help get the right parts and equipment you are looking for. Please have the machine model and serial number available in order to help us get you the correct parts. If you don't find the part on the website or on one of the online manuals, please fill out the request form and one of our experienced staff members will get back to you with a quote for the right part that your machine needs.

We sell worldwide for the brands: Genie, Terex, JLG, MultiQuip, Mikasa, Essick, Whiteman, Mayco, Toro Stone, Diamond Products, Generac Magnum, Airman, Haulotte, Barreto, Power Blanket, Nifty Lift, Atlas Copco, Chicago Pneumatic, Allmand, Miller Curber, Skyjack, Lull, Skytrak, Tsurumi, Husquvarna Target, Stow, Wacker, Sakai, Mi-T-M, Sullair, Basic, Dynapac, MBW, Weber, Bartell, Bennar Newman, Haulotte, Ditch Runner, Menegotti, Morrison, Contec, Buddy, Crown, Edco, Wyco, Bomag, Laymor, EZ Trench, Bil-Jax, F.S. Curtis, Gehl Pavers, Heli, Honda, ICS/PowerGrit, IHI, Partner, Imer, Clipper, MMD, Koshin, Rice, CH&E, General Equipment, Amida, Coleman, NAC, Gradall, Square Shooter, Kent, Stanley, Tamco, Toku, Hatz, Kohler, Robin, Wisconsin, Northrock, Oztec, Toker TK, Rol-Air, APT, Wylie, Ingersoll Rand / Doosan, Innovatech, Con X, Ammann, Mecalac, Makinex, Smith Surface Prep, Small Line, Wanco, Yanmar

A PG 450
Motor 1-Phase

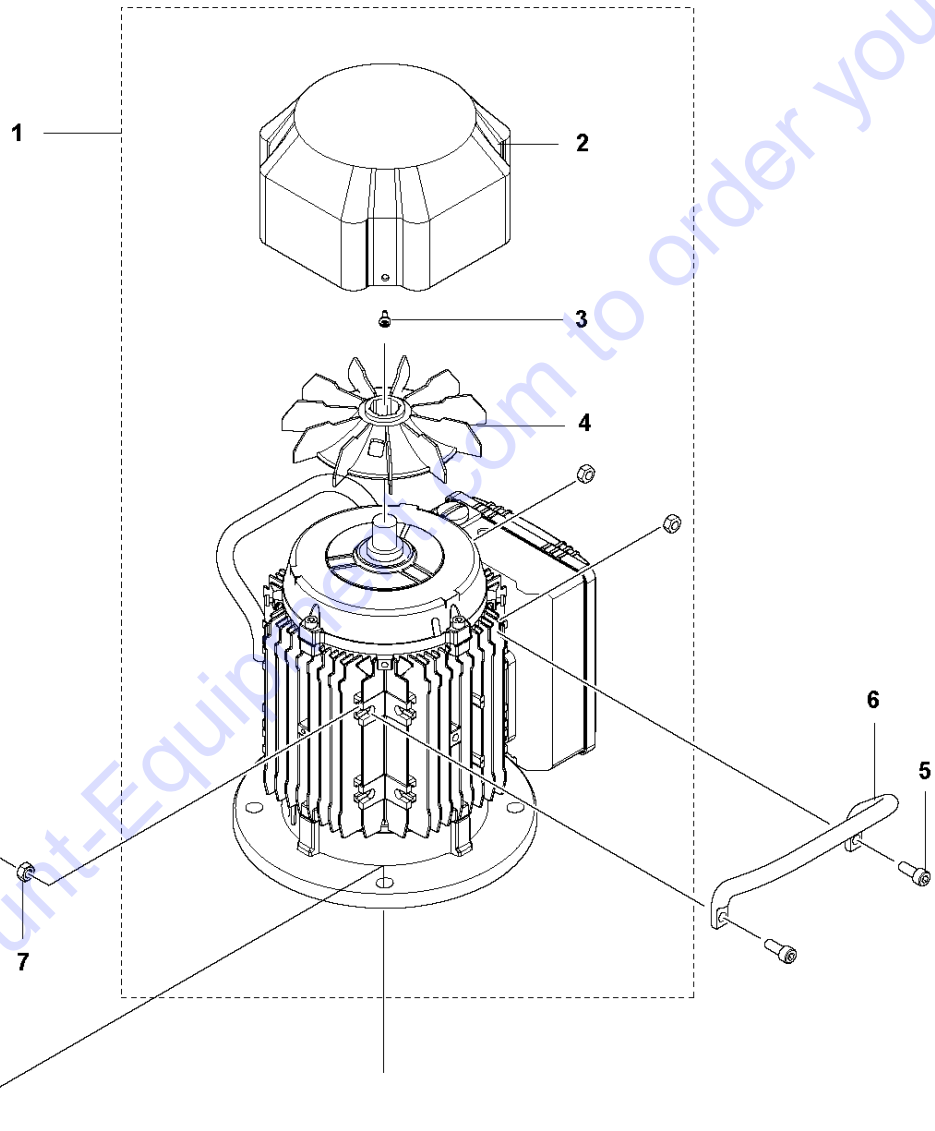

Ref	Part No	Description	Remark	QTY	KIT
1	585 19 19-01	MOTOR	2,2kw, 230V, 50Hz	1	
1	585 19 19-02	MOTOR	2,2kw, 230V, 60Hz	1	
1	585 19 22-01	MOTOR	1,5kw, 110V, 50Hz	1	
1	585 19 21-01	MOTOR	1,5kw, 110V, 60Hz	1	
2	587 17 46-01	FAN COVER		1	1
3	724 13 23-01	SCREW CRPANM		4	1
4	587 17 47-01	FAN		1	1
5	725 54 51-01	SCREW IHSCM		4	
6	585 42 33-03	HANDLE		2	
7	731 23 18-01	HEXAGON NUT		4	
8	725 25 42-71	SCREW EHHM		4	
9	734 11 78-01	WASHER		4	

Go to Discount-Equipment.com to order your parts

B PG 450
Grinding Head

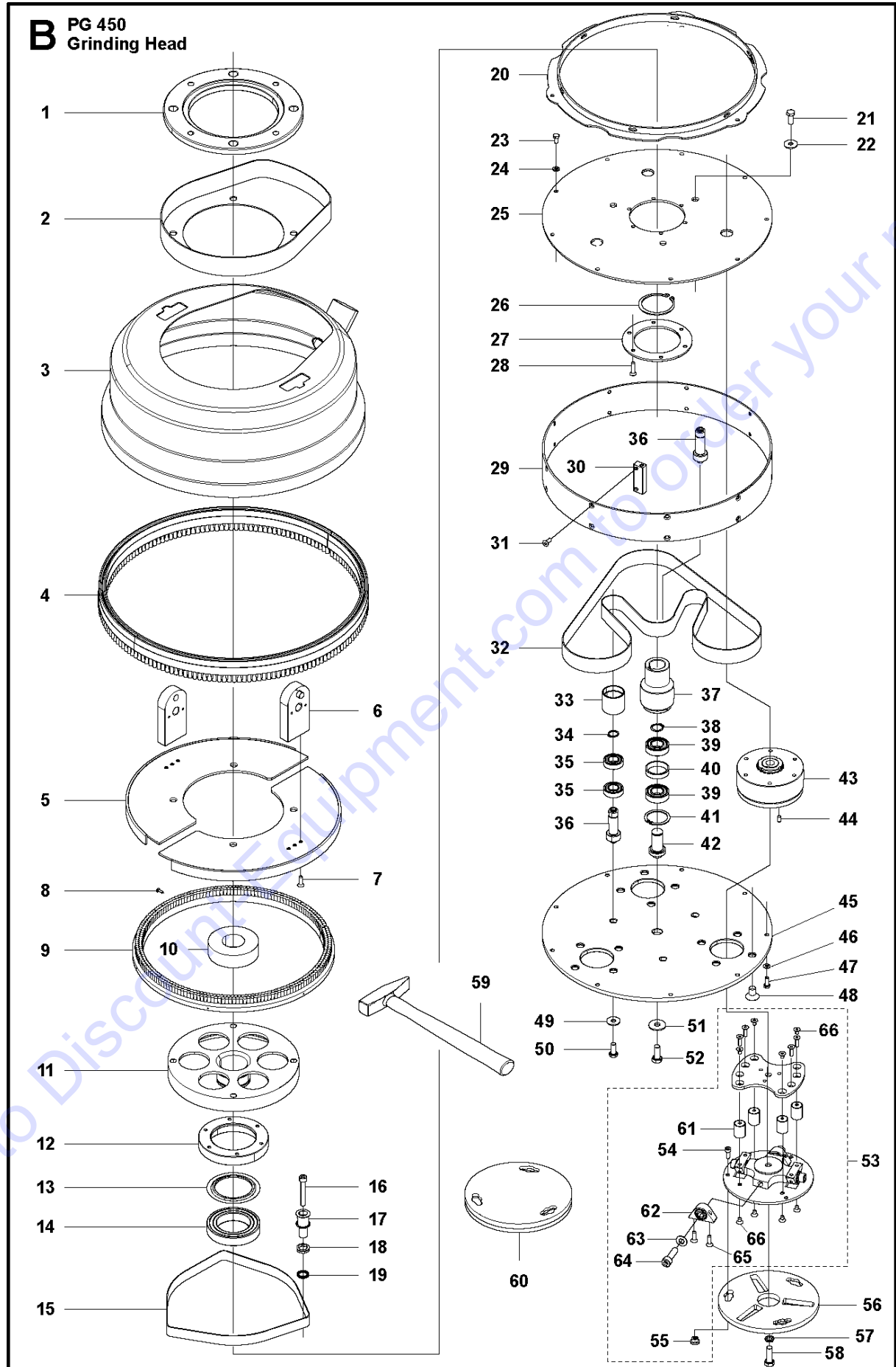

Ref	Part No	Description	Remark	QTY	KIT
1	585 08 33-02	SPACER		1	
2	584 85 10-01	GUIDE		1	
3	585 08 34-01	DUST COVER		1	
4	585 13 84-05	BRUSH		1	
5	586 85 24-01	MOUNTING PLATE		2	
6	585 54 03-01	BRACKET		2	
6	585 54 03-02	BRACKET	HDX variant only	2	
7	725 63 70-51	SCREW IHCSFM		6	
8	729 52 81-01	SCREW CRPANT		7	
9	584 83 27-02	BRUSH		1	
10	585 41 78-01	SEAL		1	
11	584 82 95-01	PLATE		1	
12	584 82 91-01	HOUSING		1	
13	584 82 92-01	SEAL		1	
14	502 56 26-01	BALL BEARING		1	
15	584 82 98-01	BELT		1	
16	725 24 62-51	SCREW EHHM		3	
17	584 83 94-01	SHAFT		3	
18	740 68 11-21	V-RING		3	
19	584 82 84-01	RADIAL SEAL		3	
20	584 83 24-01	COVER		1	
21	725 24 51-71	SCREW EHHM		3	
22	734 11 65-41	WASHER		3	
23	725 23 68-71	SCREW EHHM		9	
24	734 11 52-01	WASHER		9	
25	584 82 83-01	LID		1	
26	502 53 96-01	CIRCLIP		1	
27	584 82 94-01	COVER		1	
28	725 63 72-51	SCREW IHCSFM		6	
29	584 83 81-01	COVER		1	
30	584 83 79-01	BOSS		9	
31	725 63 68-51	SCREW IHCSFM		18	
32	584 83 16-01	BELT		1	
33	584 82 87-01	PULLEY		2	
34	735 31 19-00	CIRCLIP		2	
35	584 82 88-01	BALL BEARING		4	
36	584 82 86-01	SHAFT		3	
37	584 83 06-01	PULLEY		1	
38	735 31 22-01	CIRCLIP		1	
39	584 83 04-01	BALL BEARING		2	
40	584 83 05-01	SPACER		1	
41	735 31 38-10	CIRCLIP		1	
42	584 83 02-01	SHAFT		1	
43	584 83 07-01	PULLEY ASSY		3	
44	720 13 49-51	PARALLEL PIN		9	
45	584 83 17-01	LID		1	
46	734 11 52-01	WASHER		9	
47	725 23 68-71	SCREW EHHM		9	
48	584 83 23-01	SCREW IHCSFM		12	
49	734 11 65-41	WASHER		3	
50	725 24 51-71	SCREW EHHM		3	
51	734 11 74-41	WASHER		1	
52	725 24 93-71	SCREW EHHM		1	
53	584 81 57-01	HOLDER ASSY		3	
54	725 53 68-51	SCREW IHSCM		9	53
55	587 45 14-01	LOCK		9	53
56	584 85 02-01	HOLDER		3	
57	735 11 73-01	SPRING WASHER		3	
58	735 11 73-01	SPRING WASHER		3	
59	522 03 97-01	HAMMER		1	
60	587 41 02-02	HOLDER		3	
61	584 81 61-01	ABSORBER		1	53
62	584 81 64-01	CONNECTION		12	53
63	734 11 72-01	WASHER		12	53
64	725 54 97-01	SCREW IHSCM		12	53
65	725 63 70-51	SCREW IHCSFM		12	53
66	725 63 64-51	SCREW IHCSFM		21	53

C PG 450
Chassi

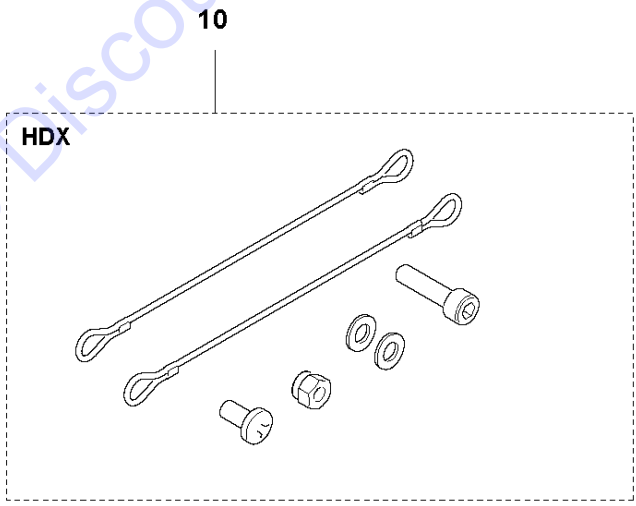
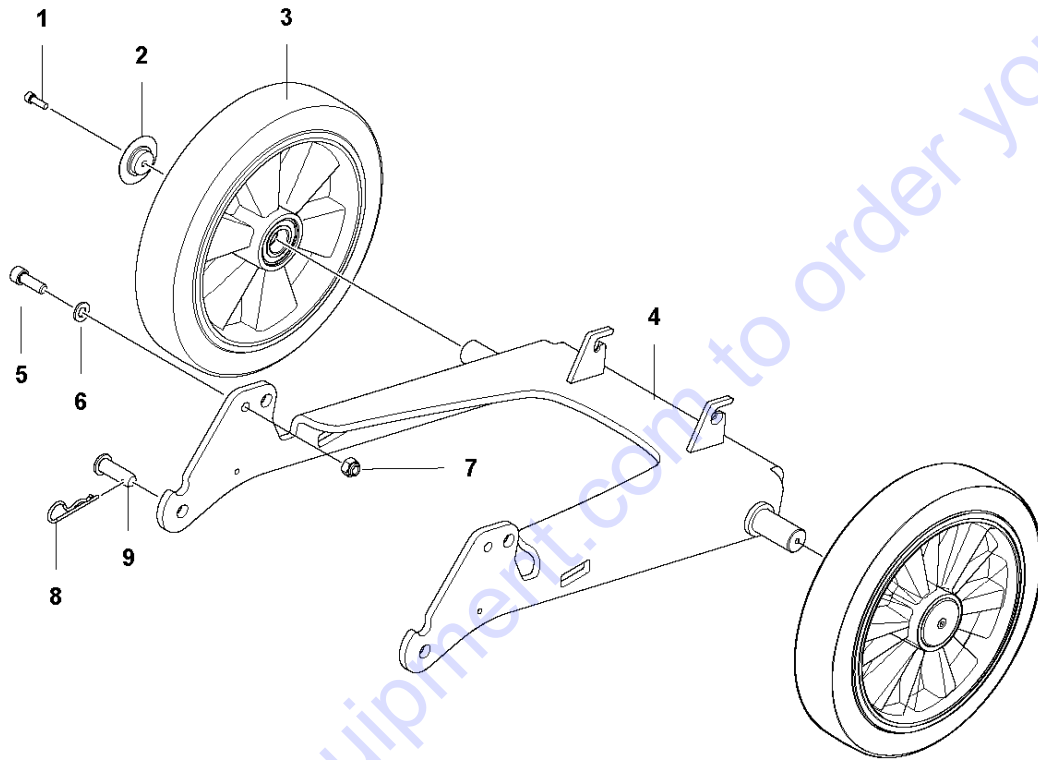

Go to Discount-Equipment.com to order your parts

Ref	Part No	Description	Remark	QTY KIT
1	725 53 70-51	SCREW IHSCM		2
2	575 39 51-01	WASHER		2
3	502 54 50-01	WHEEL		2
4	585 10 91-01	CHASSIS		1
5	725 54 95-01	SCREW IHSCM		2
6	734 11 72-01	WASHER		2
7	732 25 20-01	HEXAGON LOCKING NUT		2
8	721 68 02-51	SPRING COTTER		2
9	721 85 68-01	CLEVIS PIN		2
9	585 51 91-03	CLEVIS PIN	HDX variant only	2
10	590 54 00-01	WIRE		1

Go to Discount-Equipment.com to order your parts

D PG 450
Frame

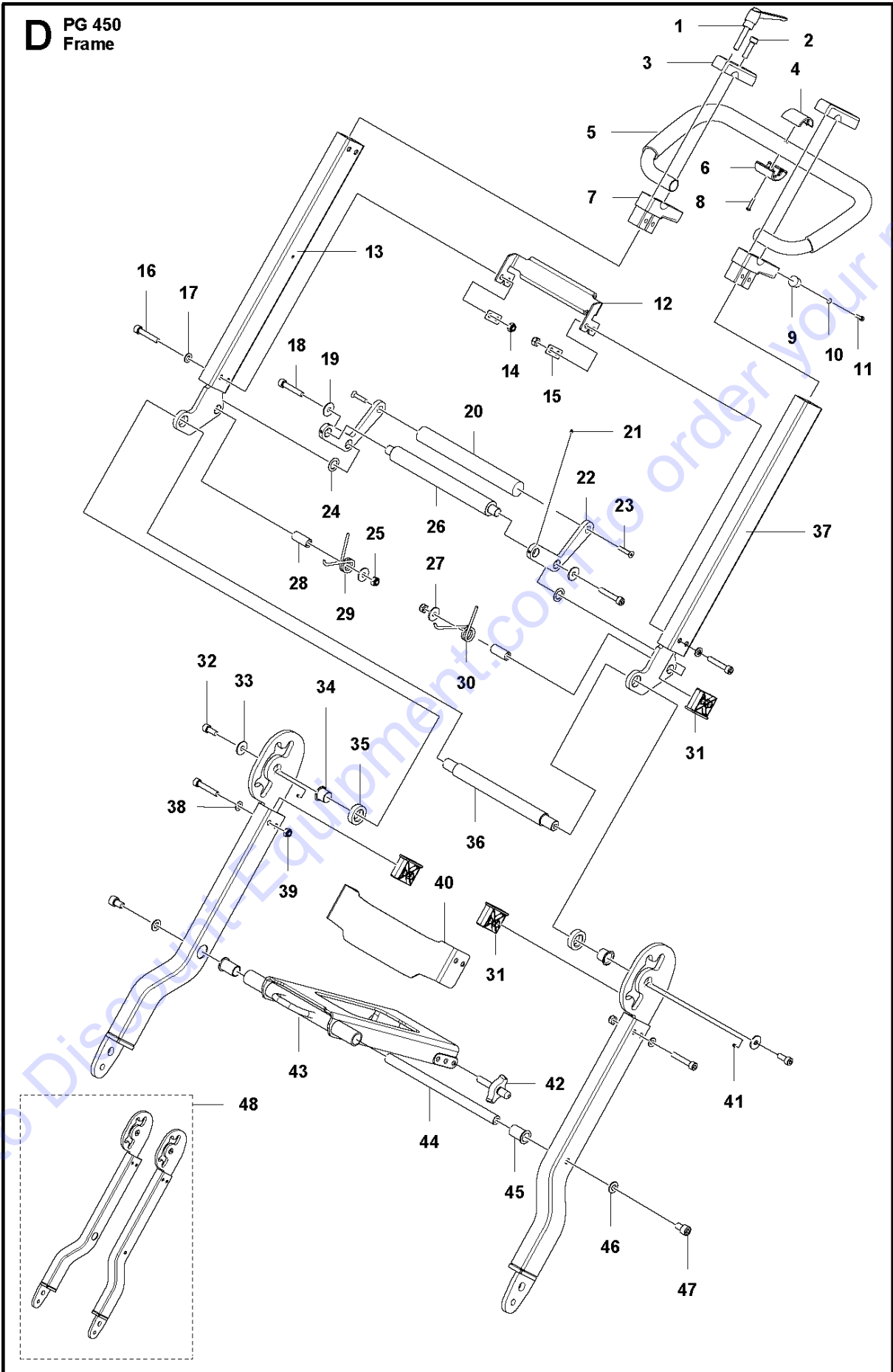

Ref	Part No	Description	Remark	QTY KIT
1	585 12 92-01	LOCKING HANDLE		2
2	725 54 55-21	SCREW IHSCM		2
3	585 51 66-01	BRACKET		2
4	587 15 85-01	COVER		1
5	585 14 40-01	HANDLE		1
6	587 15 86-01	COVER		1
7	585 51 67-01	BRACKET		2
8	729 52 61-71	SCREW CRPANT		1
9	585 51 68-01	RUBBER SHOE		2
10	734 11 36-01	WASHER		2
11	725 52 95-01	SCREW IHSCM		2
12	585 38 28-01	BRACKET		1
13	585 57 35-09	FORK		1
14	732 21 18-01	LOCK NUT		8
15	585 38 31-01	WASHER		2
16	725 54 60-01	SCREW IHSCM		8
17	725 54 60-01	SCREW IHSCM		8
18	725 54 61-01	SCREW IHSCM		2
19	734 11 65-41	WASHER		4
20	585 13 37-01	HANDLE		1
21	728 82 85-01	SCREW IHSETM		6
22	585 13 33-01	PLATE		2
23	725 63 74-51	SCREW		2
24	585 41 62-01	WASHER		2
25	732 21 18-01	LOCK NUT		2
26	585 13 38-01	ROD		1
27	734 11 65-41	WASHER		4
28	585 38 33-02	SLEEVE		2
29	585 41 73-01	SPRING		1
30	585 41 61-01	SPRING		1
31	585 13 29-01	SPACER		4
32	725 54 51-01	SCREW IHSCM		2
33	734 11 65-41	WASHER		2
34	585 41 60-01	BUSH		2
35	585 13 35-01	SPACER		2
36	585 13 36-01	TUBE		1
37	725 54 60-01	SCREW IHSCM		8
38	725 54 60-01	SCREW IHSCM		8
39	585 38 31-01	WASHER		2
40	585 38 30-01	BRACKET		1
41	728 82 85-01	SCREW IHSETM		6
42	590 47 22-01	WING KNOB		2
43	585 10 97-02	SUPPORT		1
44	585 12 90-02	TUBE		1
45	585 12 91-01	BUSH		2
46	734 11 72-01	WASHER		2
47	725 54 91-01	SCREW IHSCM		2
48	593 89 71-03	FRAME TUBE		1

Go to DiscountEquipment.com to order your parts

E PG 450
Electrical

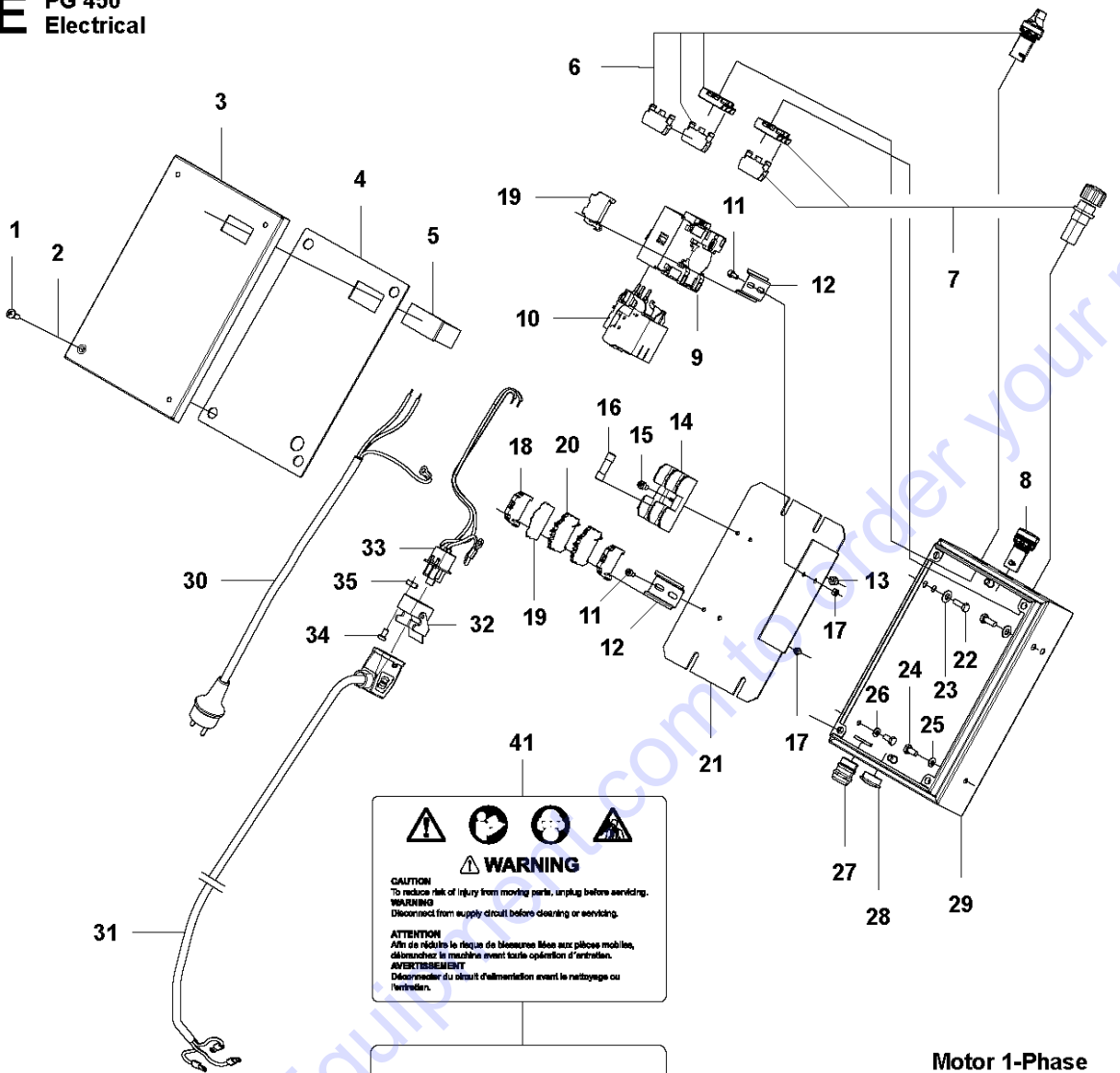

WARNING

CAUTION
To reduce risk of injury from moving parts, unplug before servicing.
NEVER USE
Disconnect from supply circuit before cleaning or servicing.

ATTENTION
Afin de réduire le risque de blessure liée aux pièces mobiles,
débranchez le machine avant toute opération d'entretien.
AVERTISSEMENT
Déconnecter du circuit d'alimentation avant le nettoyage ou l'entretien.



Motor 1-Phase

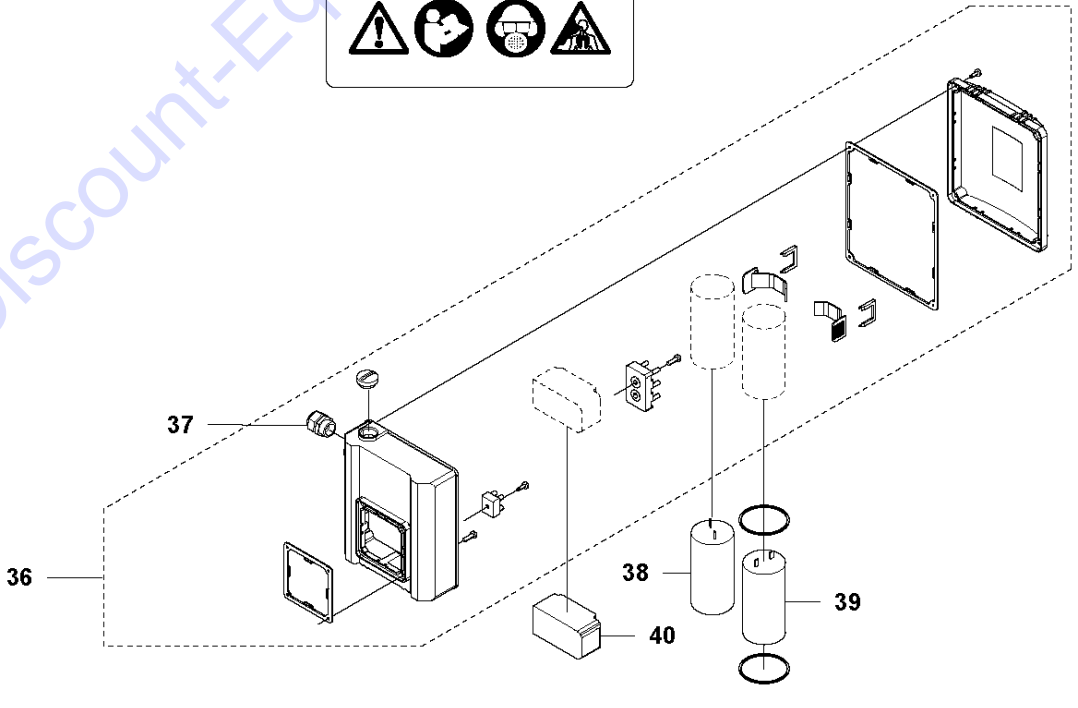

Ref	Part No	Description	Remark	QTY KIT
1	724 13 68-51	SCREW CRPANM		4
2	521 88 66-01	RIVET		4
3	586 47 43-01	LID		1
3	586 47 43-03	LID	HDX version only	1
4	586 46 70-02	SEALING		1
5	584 29 63-01	HOUR METER		1
6	586 99 15-01	SWITCH KIT		1
7	586 99 16-01	SWITCH KIT		1
8	584 29 71-01	LAMP	230V	1
8	584 29 71-02	LAMP	110V	1
9	585 36 58-01	CONTACTOR	200-230V, 50/60Hz	1
9	585 36 58-02	CONTACTOR	100-120V, 60Hz	1
9	586 99 18-01	CONTACTOR	100-120V, 50Hz	1
10	584 29 78-01	RELAY	220-240V, 60Hz	1
10	580 62 35-02	PROTECTION	220-240V, 50Hz	1
10	580 62 35-01	PROTECTION	100-120V, 60Hz	1
10	584 29 78-05	RELAY	100-120V, 50Hz	1
11	725 53 25-01	SCREW IHSCM		4
12	522 74 70-01	RAIL		2
13	731 23 16-01	HEXAGON NUT		1
14	525 88 26-01	FUSE HOLDER		1
15	725 53 64-55	SCREW IHSCM		1
16	525 63 81-01	FUSE		2
17	732 25 14-01	HEXAGON LOCKING NUT		4
18	585 36 61-05	TERMINAL BLOCK		3
19	585 36 61-03	TERMINAL BLOCK		1
19	585 36 61-07	TERMINAL BLOCK	US 100-120V	1
20	585 61 35-01	TERMINAL BLOCK		1
20	585 36 61-01	TERMINAL BLOCK	US 120V	1
21	590 07 58-01	MOUNTING PLATE		1
22	725 24 51-71	SCREW EHHM		4
23	734 11 63-01	WASHER		4
24	725 23 66-51	HEXAGONAL SCREW M6X12		2
25	734 11 52-01	WASHER		1
26	735 21 53-01	LOCKWASHER		1
27	510 43 17-01	CABLE GROMMET		1
27	587 10 12-01	GROMMET	US120V	1
28	586 58 69-01	PLUG		1
28	586 58 69-02	PLUG	US only	1
29	582 50 69-03	ELECTRONIC BOX		1
29	582 50 69-04	ELECTRONIC BOX	HDX version only	1
30	586 23 68-03	CABLE		1
30	586 23 68-02	CABLE	AUS	1
30	586 23 68-08	CABLE	BR	1
30	586 23 68-12	CABLE	US, 120V	1
30	586 23 68-13	CABLE	US 240V	1
31	585 63 81-03	CABLE		1
31	585 63 81-10	CABLE	US/CAN, 240V	1
31	585 63 81-11	CABLE	US/CAN, 120V	1
32	585 36 66-05	CONNECTOR		1
33	590 50 35-01	CONNECTOR		1
34	725 52 24-01	SCREW		2
35	732 25 10-01	HEXAGON LOCKING NUT		2
36	587 17 39-01	ELECTRONIC BOX		1
37	510 43 17-02	CABLE GROMMET		1
37	587 10 12-01	GROMMET	US120V	1
38	587 17 45-01	CAPACITOR	230V, 50/60Hz	1
38	587 17 45-02	CAPACITOR	110V, 50/60Hz	1
39	587 17 44-01	CAPACITOR	230V, 50Hz	1
39	587 17 44-02	CAPACITOR	230V, 60Hz	1
39	587 17 44-03	CAPACITOR	110V, 50/60Hz	1
40	587 17 43-01	SWITCH	230V, 50Hz	1
40	587 17 43-02	SWITCH	208-230V, 60Hz	1
40	587 17 43-03	SWITCH	110V, 50/60Hz	1
41	590 51 83-01	DECAL	US, CAN	1
41	590 51 84-01	DECAL	ROW	1

PARTS FINDER

**Search Website
by Part Number**



**Search Manual
Library For Parts
Manual & Lookup Part
Numbers – Purchase
or Request Quote**

Search Manuals

Enter your information to help us find the right parts manual for your machine.

* Brand:

* Model:

* Serial:

* Part Number:

SEARCH

**Can't Find Part or
Manual? Request Help
by Manufacturer,
Model & Description**

Parts Order Form

Please fill in the following information to help us find the right part for your machine.

Manufacturer:

Model:

Description:

Part Number:

Quantity:

Submit

Discount-Equipment.com is your online resource for quality parts & equipment.

Florida: **561-964-4949** Outside Florida TOLL FREE: **877-690-3101**

Need parts?

Click on this link: <http://www.discount-equipment.com/category/5443-parts/> and choose one of the options to help get the right parts and equipment you are looking for. Please have the machine model and serial number available in order to help us get you the correct parts. If you don't find the part on the website or on one of the online manuals, please fill out the request form and one of our experienced staff members will get back to you with a quote for the right part that your machine needs.

We sell worldwide for the brands: Genie, Terex, JLG, MultiQuip, Mikasa, Essick, Whiteman, Mayco, Toro Stone, Diamond Products, Generac Magnum, Airman, Haulotte, Barreto, Power Blanket, Nifty Lift, Atlas Copco, Chicago Pneumatic, Allmand, Miller Curber, Skyjack, Lull, Skytrak, Tsurumi, Husquvarna Target, Stow, Wacker, Sakai, Mi-T-M, Sullair, Basic, Dynapac, MBW, Weber, Bartell, Bennar Newman, Haulotte, Ditch Runner, Menegotti, Morrison, Contec, Buddy, Crown, Edco, Wyco, Bomag, Laymor, EZ Trench, Bil-Jax, F.S. Curtis, Gehl Pavers, Heli, Honda, ICS/PowerGrit, IHI, Partner, Imer, Clipper, MMD, Koshin, Rice, CH&E, General Equipment, Amida, Coleman, NAC, Gradall, Square Shooter, Kent, Stanley, Tamco, Toku, Hatz, Kohler, Robin, Wisconsin, Northrock, Oztec, Toker TK, Rol-Air, APT, Wylie, Ingersoll Rand / Doosan, Innovatech, Con X, Ammann, Mecalac, Makinex, Smith Surface Prep, Small Line, Wanco, Yanmar