

PP 480 HF

Reservdelar

Spare parts

Ersatzteile

Pieces de rechange

Piezas de repuesto

Ricambi

Peças sobresselente



# PARTS FINDER

**Search Website  
by Part Number**



**Search Manual  
Library For Parts  
Manual & Lookup Part  
Numbers – Purchase  
or Request Quote**

**Search Manuals**

Enter your information to help us find the right parts manual for your machine.

\* Brand:

\* Model:

\* Serial:

\* Part Number:

SEARCH

**Can't Find Part or  
Manual? Request Help  
by Manufacturer,  
Model & Description**

**Parts Order Form**

Please fill in the following information to help us find the right part for your machine.

Manufacturer:	<input type="text"/>
Model:	<input type="text"/>
Description:	<input type="text"/>
Part Number:	<input type="text"/>
Quantity:	<input type="text"/>
Notes:	<input type="text"/>

Discount-Equipment.com is your online resource for quality parts & equipment.

Florida: **561-964-4949** Outside Florida TOLL FREE: **877-690-3101**

**Need parts?**

Click on this link: <http://www.discount-equipment.com/category/5443-parts/> and choose one of the options to help get the right parts and equipment you are looking for. Please have the machine model and serial number available in order to help us get you the correct parts. If you don't find the part on the website or on one of the online manuals, please fill out the request form and one of our experienced staff members will get back to you with a quote for the right part that your machine needs.

We sell worldwide for the brands: Genie, Terex, JLG, MultiQuip, Mikasa, Essick, Whiteman, Mayco, Toro Stone, Diamond Products, Generac Magnum, Airman, Haulotte, Barreto, Power Blanket, Nifty Lift, Atlas Copco, Chicago Pneumatic, Allmand, Miller Curber, Skyjack, Lull, Skytrak, Tsurumi, Husquvarna Target, Stow, Wacker, Sakai, Mi-T-M, Sullair, Basic, Dynapac, MBW, Weber, Bartell, Bennar Newman, Haulotte, Ditch Runner, Menegotti, Morrison, Contec, Buddy, Crown, Edco, Wyco, Bomag, Laymor, EZ Trench, Bil-Jax, F.S. Curtis, Gehl Pavers, Heli, Honda, ICS/PowerGrit, IHI, Partner, Imer, Clipper, MMD, Koshin, Rice, CH&E, General Equipment, Amida, Coleman, NAC, Gradall, Square Shooter, Kent, Stanley, Tamco, Toku, Hatz, Kohler, Robin, Wisconsin, Northrock, Oztec, Toker TK, Rol-Air, APT, Wylie, Ingersoll Rand / Doosan, Innovatech, Con X, Ammann, Mecalac, Makinex, Smith Surface Prep, Small Line, Wanco, Yanmar

No.	Pos.	Description	No.	Pos.	Description
505 24 70-01	B	Shackle	531 11 80-03	C	Quick coupling, female 1800 uv
505 24 70-01	F	Shackle	531 11 80-05	C	Nipple 1812
505 25 71-01	E	Cable	531 11 80-18	C	Ball valve 3/8
505 26 61-01	A	O-ring	531 11 82-19	C	Quick coupling, female 1300 UV
505 32 70-01	E	Cover	531 11 83-54	C	Nipple 18110 with net
505 32 70-01	F	Cover	531 11 90-14	C	Hose clamp 13-20
505 40 74-01	C	Nipple 3/8"	531 11 90-18	B	Distance
505 42 42-01	C	Valve Assembled	531 11 92-08	B	Screw
505 46 11-01	B	Emergency stop	531 11 92-60	B	Washer
505 46 12-01	B	Adapter	531 11 93-37	A	Plug
505 46 13-01	B	Contact	531 11 93-89	B	Screw MLC6S 5x10
505 52 62-01	B	Gasket kit	531 11 95-86	B	Screw MRX M3x5
505 52 64-01	B	Switch	531 12 32-48	F	Cable
505 52 67-01	B	Protective shutter	531 12 32-48	F	Cable complete
505 52 68-01	B	Socket	531 12 33-61	D	Bumper
505 52 69-01	B	Cable grommet M16	531 12 33-62	B	Attachment plate
505 52 69-02	B	Cable grommet M20	531 12 34-00	A	End cover inlet side
505 52 69-03	B	Cable grommet M25	531 12 34-01	A	End cover outlet side 5-pin
505 52 72-01	D	Handle	531 12 34-02	A	Partition
505 52 73-01	C	Water valve	531 12 34-09	B	Conduit entry
505 52 74-01	B	Transformer 400-480V	531 12 34-10	C	Water inlet connection
505 52 76-01	E	Cable kit	531 12 34-11	C	Distance coupling
505 52 77-01	E	Cable kit	531 12 34-12	C	Clamping washer
505 52 78-01	E	Cable kit	531 12 34-13	C	Water connection
505 52 82-01	B	Distance	531 12 34-16	D	Foot
505 52 83-01	B	Screw MC6S 4x5	531 12 34-17	A	Locking sleeve
505 52 84-01	B	Ventilating valve	574 02 85-01	B	Radio card
505 52 85-01	A	Sealing strip	574 18 48-01	C	Bracket
505 52 87-01	BE	Consol 6-pole	574 24 65-01	B	Angle bracket
505 52 88-01	BE	Consol 3-pole	575 22 93-01	G	Contact, USB
505 52 89-01	B	Frame	575 24 22-01	G	Lid
505 52 92-01	B	Contact housing	575 33 54-01	B	Cover
505 56 87-01	C	Water connection	575 61 74-01	B	Screw
506 29 76-61	H	Harness	575 61 74-02	B	Screw
506 74 83-01	C	Valve Assembled	575 61 74-03	ABD	Screw
510 03 83-01	A	End cover outlet side 5-pin 4-pin	575 64 71-01	B	Lamp
510 10 85-01	G	Cover plate	575 95 08-01	F	Cable grommet
510 10 91-01	G	Battery	576 25 34-01	G	Handle assy
510 28 03-01	H	Battery charger	576 25 93-02	G	Rcc unit complete
510 28 07-01	H	Cable, EUR	576 25 94-01	G	Knob
510 28 07-02	H	Cable, US	576 26 16-01	G	O-ring
510 28 07-04	H	Cable, Australia	576 26 23-02	G	Circuit board
510 28 50-04	H	Battery charger assy	576 81 51-01	G	Switch
522 52 50-01	B	Plate	576 87 78-01	G	Contact, CAN
522 61 52-01	A	Base plate	576 88 80-02	G	Sealing strip
522 61 53-01	A	Upper support	577 48 02-01	H	CAN cable
522 61 59-01	D	Gable top	677 62 68-01	B	Main board PP440/480HF v2.5
522 61 60-01	A	Cover strip lower	577 63 36-01	B	Main board PP440/480HF v2.4
522 61 61-01	D	Box side	577 63 37-01	B	Main board PP440/480HF v2.41
522 61 64-01	A	Printed circiut assy complete	577 70 91-01	G	Decals
522 92 82-03	A	Printed circuit assy 400-480V	577 70 93-01	G	Display kit
522 93 07-01	F	Module 6-pin	577 70 94-01	G	Potentiometer
522 93 08-01	F	Contact pin 0,75mm <sup>2</sup>	577 70 95-01	G	Potentiometer
522 93 14-01	F	Housing	577 71 05-01	G	Cover assy
522 93 15-01	F	Frame	577 71 10-01	G	Spring pin, kit with washer
522 93 17-01	F	Contact pin	577 73 55-01	G	Knob
522 93 18-01	F	Contact pin	577 76 37-01	G	Battery
522 93 20-01	F	Housing	578 31 05-01	B	Gasket
522 93 21-01	F	Module 3-pin	578 77 61-01	G	Screw
522 93 22-01	F	Contact pin	578 77 61-02	G	Screw
522 93 41-01	F	Pliar	723 12 20-01	B	Screw MCS 3x6
522 93 43-01	F	Removal tool	723 12 91-01	B	Screw MCS 4x12
522 93 44-01	F	Removal tool	725 52 20-01	B	Screw MC6S 3x6
523 00 52-01	G	Screw	725 52 85-01	C	Screw MC6S 4x6
525 58 22-01	D	Distance	725 53 29-01	C	Screw MC6S M5x16
531 11 71-52	B	Electric inlet 32A 400V	725 53 31-01	B	Screw MC6S 5x20
531 11 72-08	B	Personal Safety Guard	725 53 33-01	C	Screw MC6S 5x25
531 11 72-22	B	Contactoer 400-480V	725 53 78-01	D	Screw MC6S 6x40
531 11 73-20	F	Contact pin 2,5mm <sup>2</sup>	725 54 63-01	D	Screw MC6S 8x60
531 11 73-62	F	Contact pin	725 54 69-51	D	Screw MC6S 8x90

No.	Pos.	Description	No.	Pos.	Description
725 63 74-51	A	Screw MF6S 6x30 10.9			
725 64 91-01	D	Screw MF6S 10x20			
728 73 70-05	A	Stop screw S6SS 6x20			
732 25 16-01	A	Nut M6 Nylock			
732 25 18-01	D	Nut M8 Nylock			
734 11 23-71	B	Washer 3.2x6			
734 11 24-01	G	Washer			
734 11 35-71	BC	Washer 4.3x8			
734 11 46-01	BC	Washer 5,3x10x1			
734 11 52-01	AD	Washer 6.4x12			
734 11 63-01	D	Washer 8.4x16			
740 38 27-01	C	Sealing ring 1/4			
740 42 08-00	C	O-ring 10,1x1,6			
740 43 09-00	C	O-ring 11,3x2,4			
740 43 13-00	C	O-ring 15,3x2,4			

Go to [Discount-Equipment.com](http://Discount-Equipment.com) to order your parts

**A** PP 480 HF

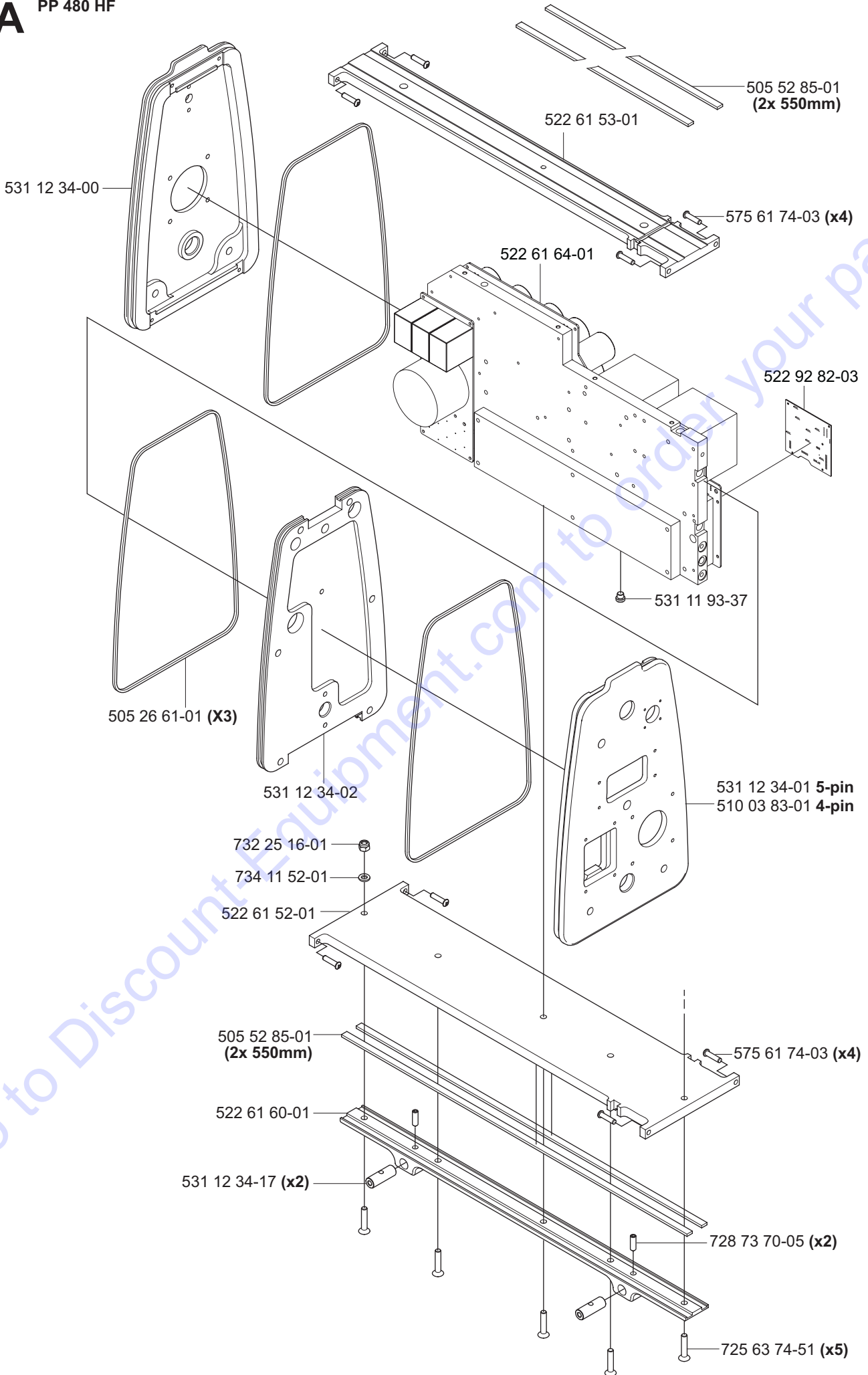

# B PP 480 HF

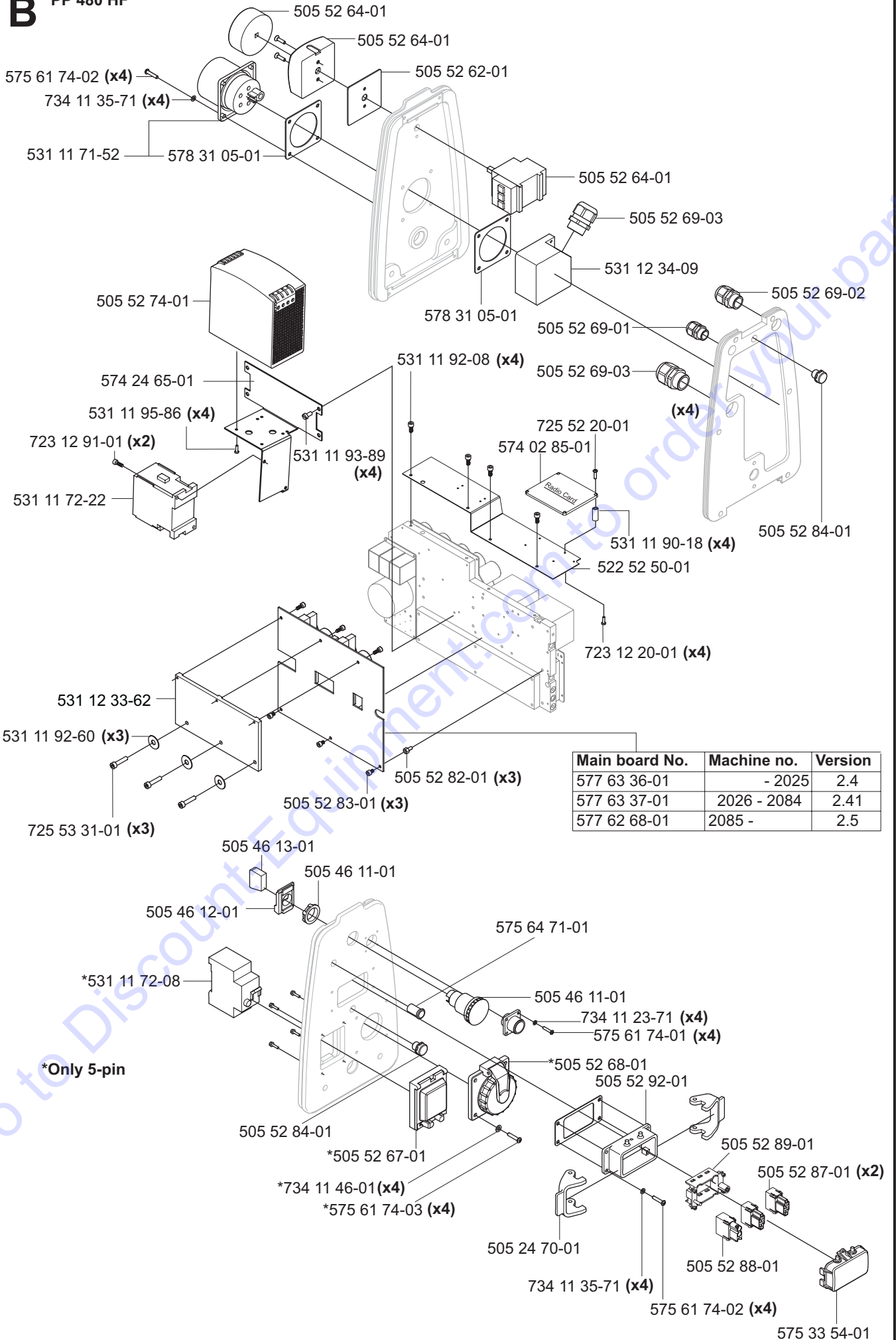

**C**

**PP 480 HF**

**\*Complete**  
505 42 42-01

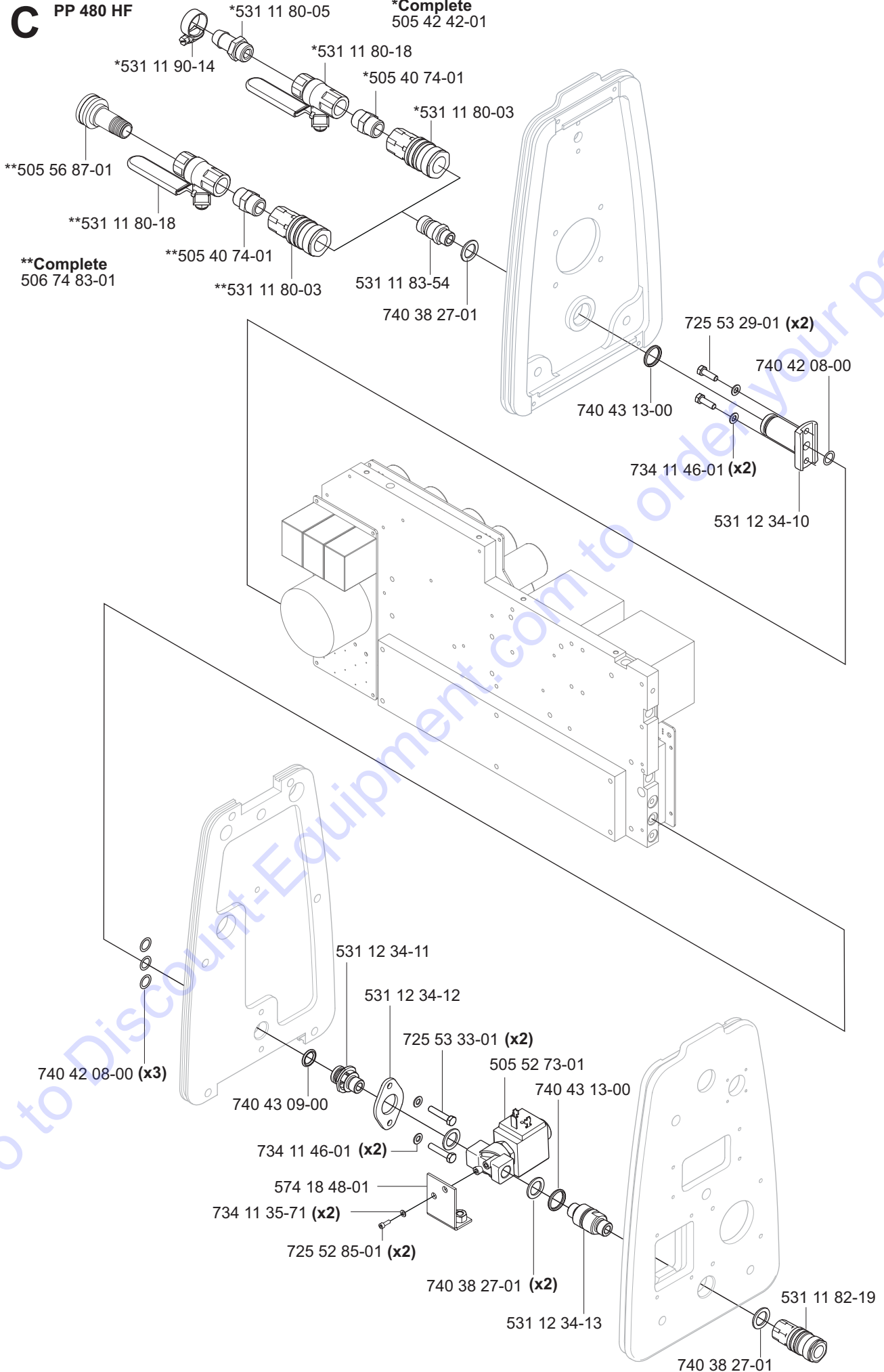

**D** PP 480 HF

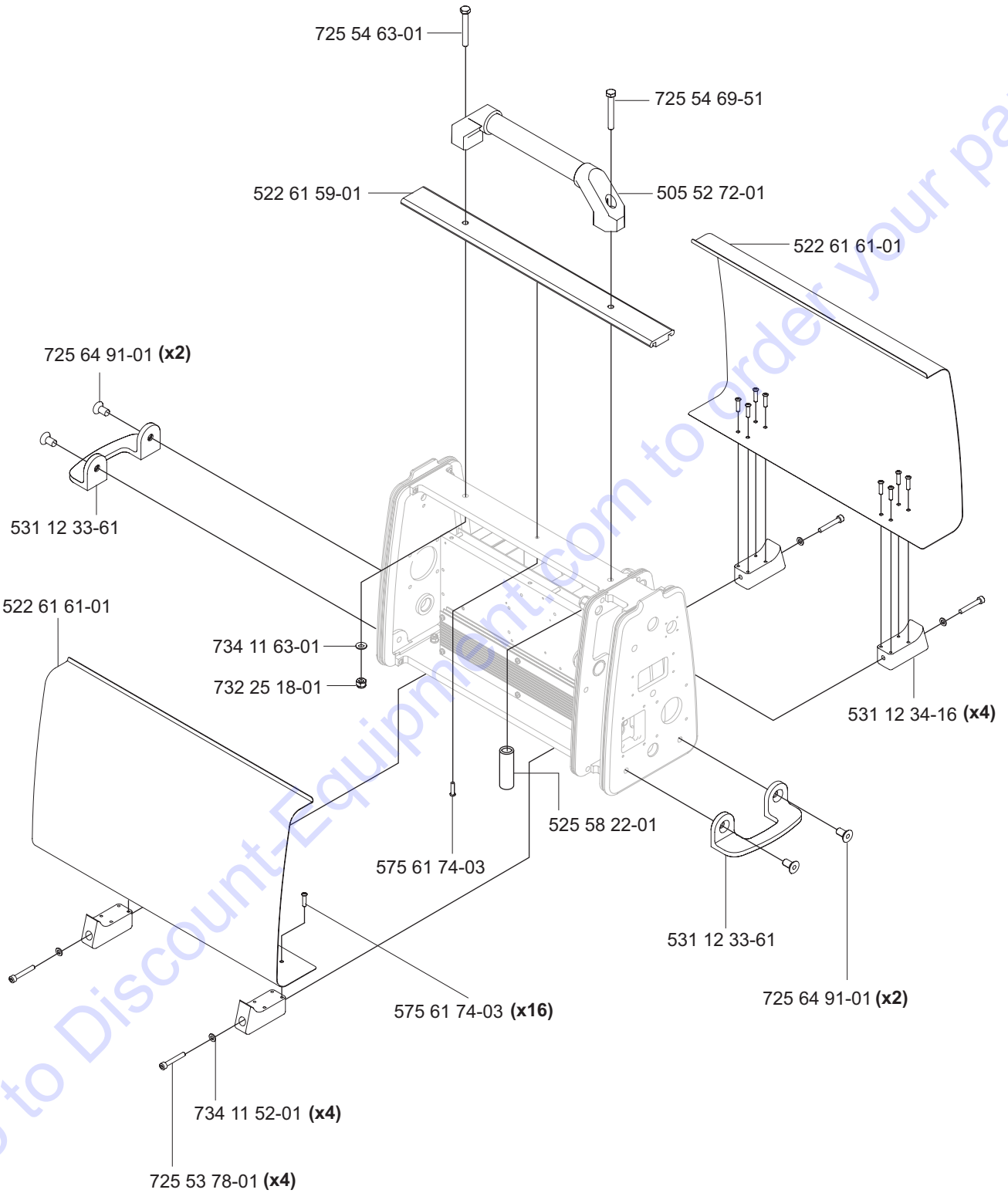



**E**

PP 480 HF

505 25 71-01

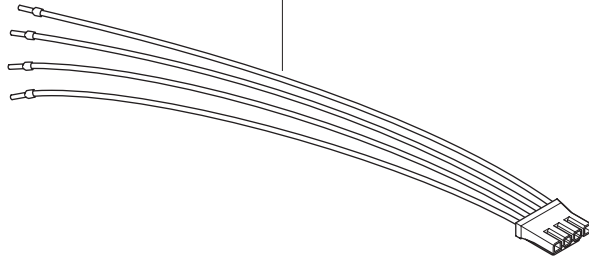

505 52 76-01

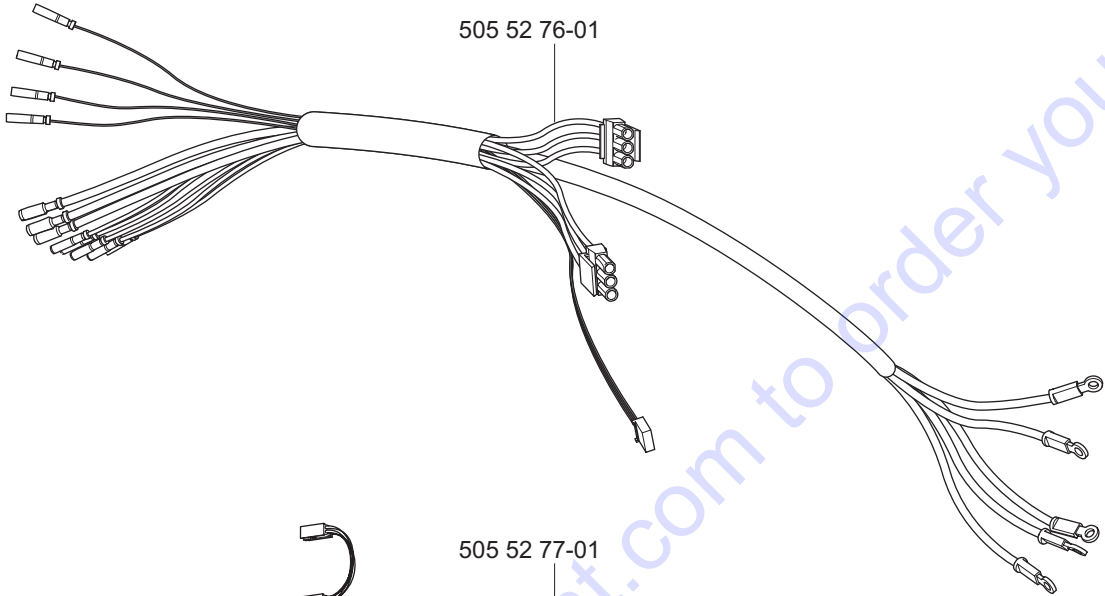

505 52 77-01

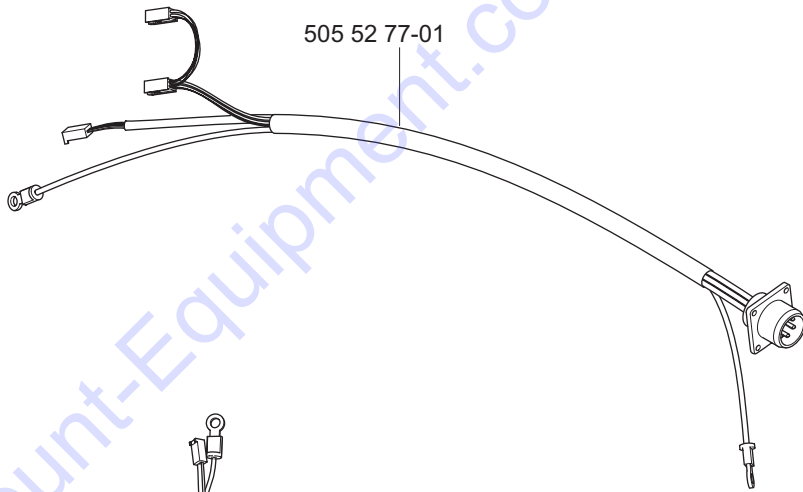

505 52 78-01

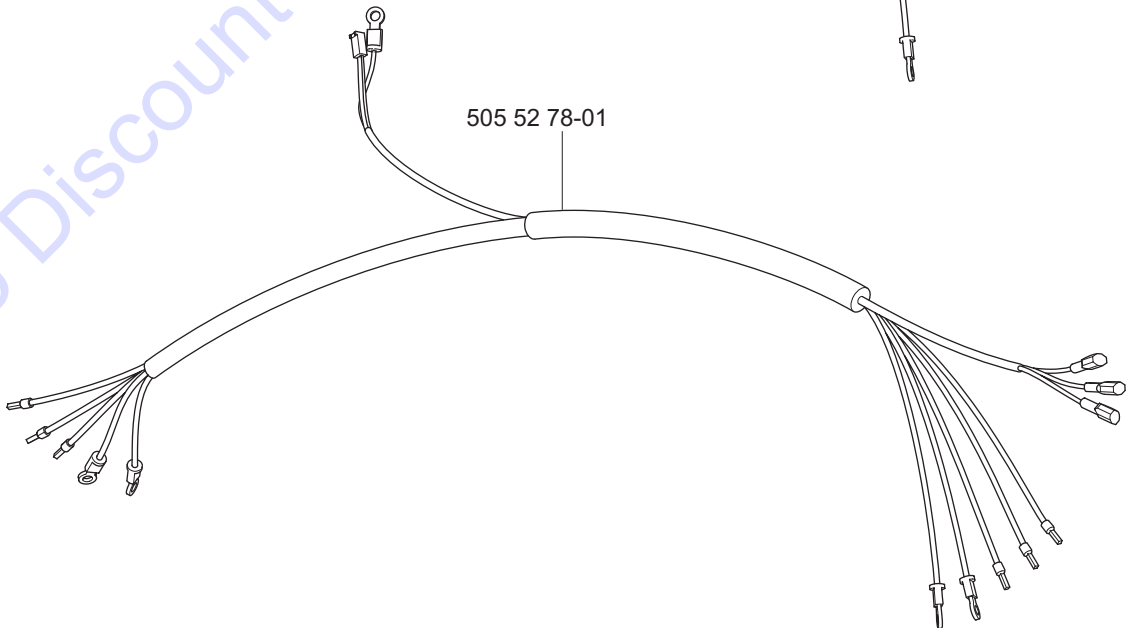

Go to Discount-Equipment.com to order your parts

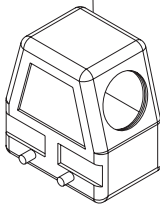
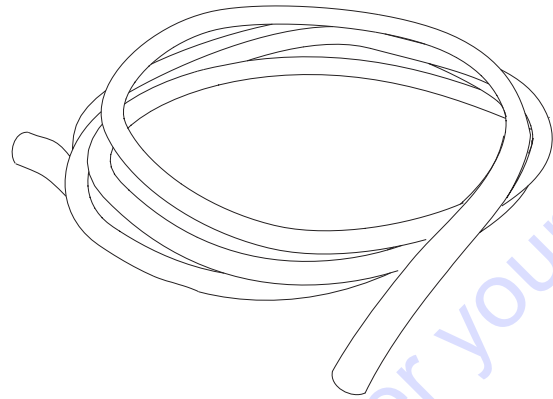
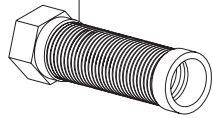
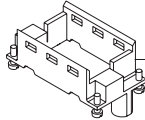
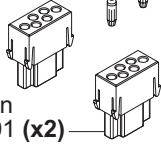
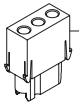
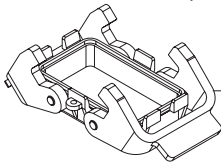
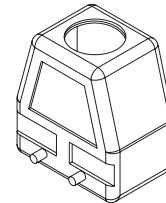
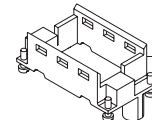
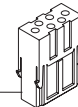
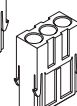
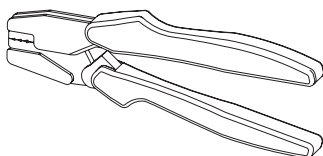
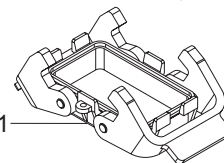
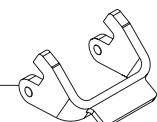
**F****PP 480 HF****Cable complete 531 12 32-48**Housing  
522 93 14-01Cable grommet  
575 95 08-01Frame  
522 93 15-01Contact pin  
female 0,75mm<sup>2</sup>  
522 93 18-01 (x4)Contact pin female  
2,5mm<sup>2</sup> 531 11 73-62 (x8)Contact pin female 4mm<sup>2</sup>  
522 93 17-01 (x3)Module 6-pin  
505 52 87-01 (x2)Module 3-pin  
505 52 88-01Cable grommet  
575 95 08-01Cover  
505 32 70-01Housing  
522 93 20-01Frame  
522 93 15-01Removal tool for  
contact pins 0,75-2,5mm<sup>2</sup>  
522 93 44-01Contact pin male 2,5mm<sup>2</sup>  
531 11 73-20 (x8)Contact pin male 0,75mm<sup>2</sup>  
522 93 08-01 (x4)Contact pin male 4mm<sup>2</sup>  
522 93 22-01 (x3)Module 6-pin  
522 93 07-01 (x2)Module 3-pin  
522 93 21-01Removal tool for  
contact pins 4mm<sup>2</sup>  
522 93 43-01Cover  
505 32 70-01Pliar for contact pins  
522 93 41-01Shackle  
505 24 70-01

576 25 93-02

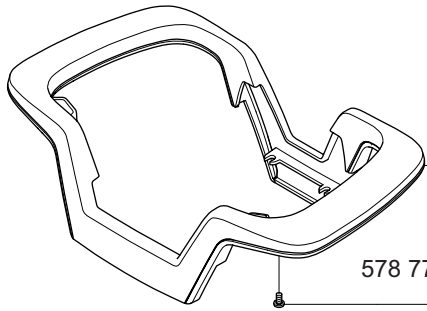

576 81 51-01

576 25 34-01

578 77 61-01 (x6)

577 71 05-01

577 70 95-01

576 25 94-01 (x2)

577 70 91-01

577 70 93-01

578 77 61-02 (x8)

576 26 16-01 (x2)

576 88 80-02

577 73 55-01

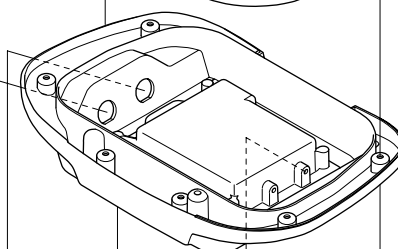
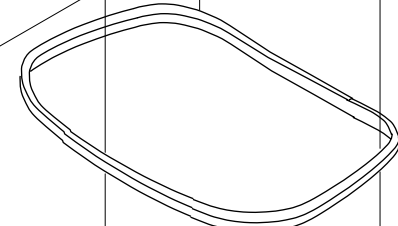
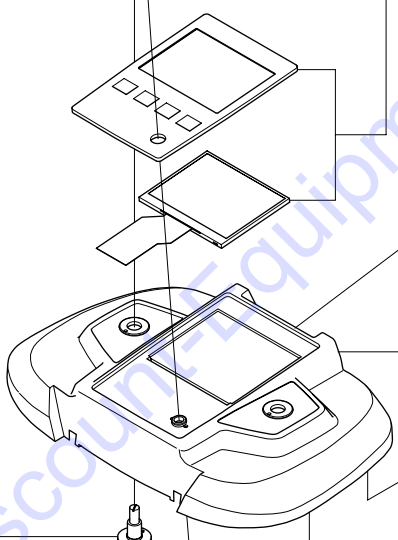

577 70 94-01

575 24 22-01 (x2)

575 22 93-01

734 11 24-01 (x2)

577 71 10-01 (x2)

576 87 78-01

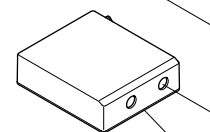

510 10 91-01

576 26 23-02

577 76 37-01

578 77 61-01 (x4)

523 00 52-01 (x4)

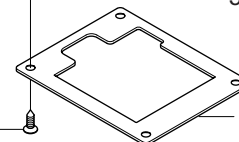

510 10 85-01

Go to Discount Equipment.com to order your parts

**H** PP 480 HF  
RCC-UNIT

506 29 76-61

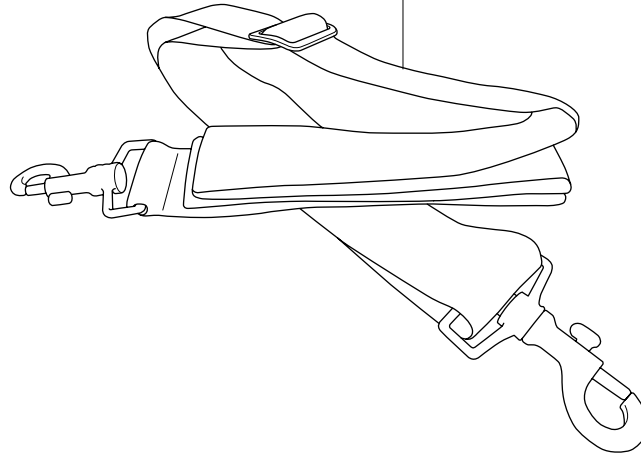

510 28 50-04

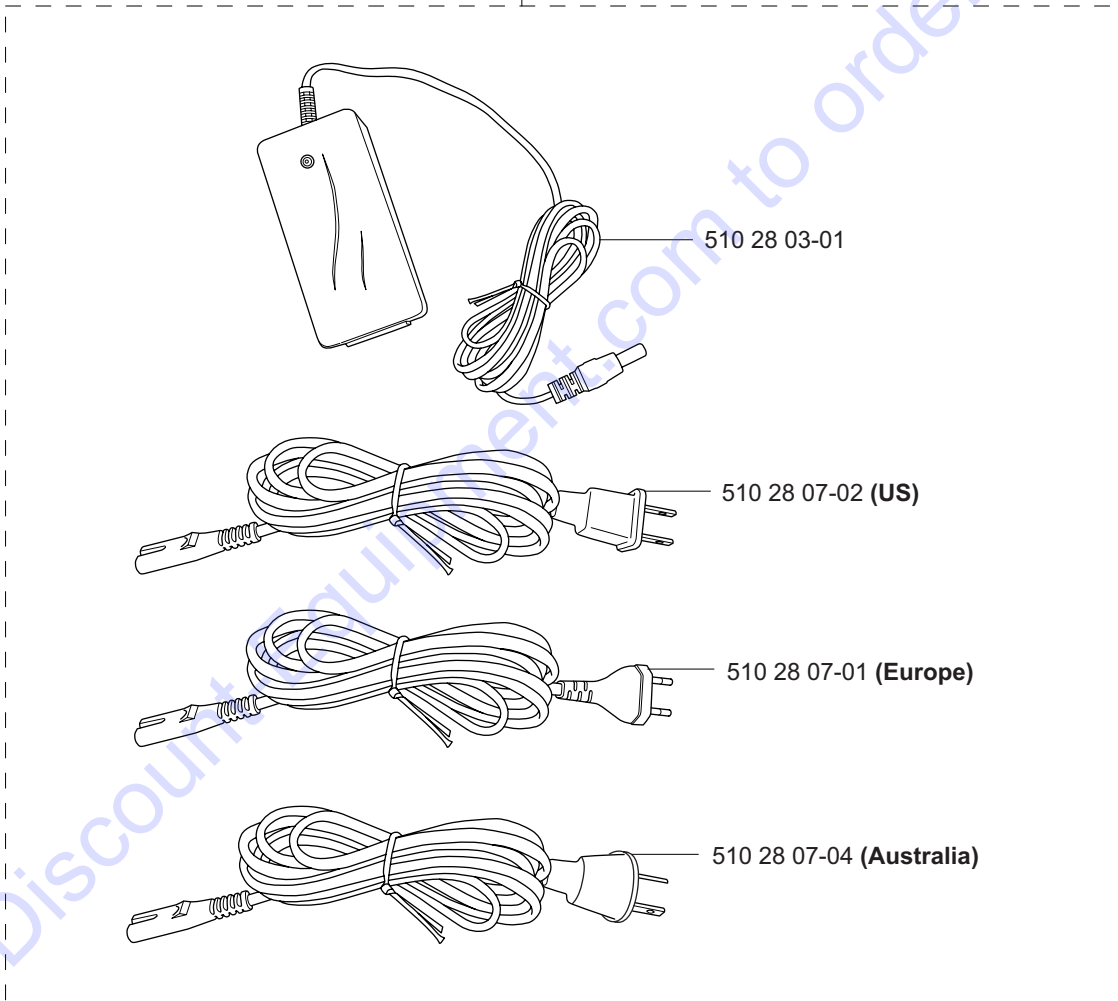

510 28 03-01

510 28 07-02 (US)

510 28 07-01 (Europe)

510 28 07-04 (Australia)

577 48 02-01

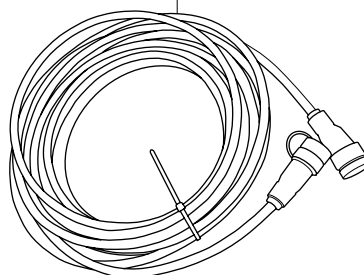

# PARTS FINDER

**Search Website  
by Part Number**



**Search Manual  
Library For Parts  
Manual & Lookup Part  
Numbers – Purchase  
or Request Quote**

**Search Manuals**

Enter your information to help us find the right parts manual for your machine.

\* Brand:

\* Model:

\* Serial:

\* Part Number:

SEARCH

**Can't Find Part or  
Manual? Request Help  
by Manufacturer,  
Model & Description**

**Parts Order Form**

Please fill in the following information to help us find the right part for your machine.

Manufacturer:	<input type="text"/>
Model:	<input type="text"/>
Description:	<input type="text"/>
Part Number:	<input type="text"/>
Quantity:	<input type="text"/>
Notes:	<input type="text"/>

Discount-Equipment.com is your online resource for quality parts & equipment.

Florida: **561-964-4949** Outside Florida TOLL FREE: **877-690-3101**

**Need parts?**

Click on this link: <http://www.discount-equipment.com/category/5443-parts/> and choose one of the options to help get the right parts and equipment you are looking for. Please have the machine model and serial number available in order to help us get you the correct parts. If you don't find the part on the website or on one of the online manuals, please fill out the request form and one of our experienced staff members will get back to you with a quote for the right part that your machine needs.

We sell worldwide for the brands: Genie, Terex, JLG, MultiQuip, Mikasa, Essick, Whiteman, Mayco, Toro Stone, Diamond Products, Generac Magnum, Airman, Haulotte, Barreto, Power Blanket, Nifty Lift, Atlas Copco, Chicago Pneumatic, Allmand, Miller Curber, Skyjack, Lull, Skytrak, Tsurumi, Husquvarna Target, Stow, Wacker, Sakai, Mi-T-M, Sullair, Basic, Dynapac, MBW, Weber, Bartell, Bennar Newman, Haulotte, Ditch Runner, Menegotti, Morrison, Contec, Buddy, Crown, Edco, Wyco, Bomag, Laymor, EZ Trench, Bil-Jax, F.S. Curtis, Gehl Pavers, Heli, Honda, ICS/PowerGrit, IHI, Partner, Imer, Clipper, MMD, Koshin, Rice, CH&E, General Equipment, Amida, Coleman, NAC, Gradall, Square Shooter, Kent, Stanley, Tamco, Toku, Hatz, Kohler, Robin, Wisconsin, Northrock, Oztec, Toker TK, Rol-Air, APT, Wylie, Ingersoll Rand / Doosan, Innovatech, Con X, Ammann, Mecalac, Makinex, Smith Surface Prep, Small Line, Wanco, Yanmar