

WS 482 HF

Reservdelar

Spare parts

Ersatzteile

Pieces de rechange

Piezas de repuesto

Ricambi

Peças sobresselente



PARTS FINDER

**Search Website
by Part Number**



**Search Manual
Library For Parts
Manual & Lookup Part
Numbers – Purchase
or Request Quote**

Search Manuals

Enter your information to help us find the right parts manual for your machine.

* Brand:

* Model:

* Serial:

* Part Number:

SEARCH

**Can't Find Part or
Manual? Request Help
by Manufacturer,
Model & Description**

Parts Order Form

Please fill in the following information to help us find the right part for your machine.

Manufacturer:	<input type="text"/>
Model:	<input type="text"/>
Description:	<input type="text"/>
Part Number:	<input type="text"/>
Quantity:	<input type="text"/>
Notes:	<input type="text"/>

Discount-Equipment.com is your online resource for quality parts & equipment.

Florida: **561-964-4949** Outside Florida TOLL FREE: **877-690-3101**

Need parts?

Click on this link: <http://www.discount-equipment.com/category/5443-parts/> and choose one of the options to help get the right parts and equipment you are looking for. Please have the machine model and serial number available in order to help us get you the correct parts. If you don't find the part on the website or on one of the online manuals, please fill out the request form and one of our experienced staff members will get back to you with a quote for the right part that your machine needs.

We sell worldwide for the brands: Genie, Terex, JLG, MultiQuip, Mikasa, Essick, Whiteman, Mayco, Toro Stone, Diamond Products, Generac Magnum, Airman, Haulotte, Barreto, Power Blanket, Nifty Lift, Atlas Copco, Chicago Pneumatic, Allmand, Miller Curber, Skyjack, Lull, Skytrak, Tsurumi, Husquvarna Target, Stow, Wacker, Sakai, Mi-T-M, Sullair, Basic, Dynapac, MBW, Weber, Bartell, Bennar Newman, Haulotte, Ditch Runner, Menegotti, Morrison, Contec, Buddy, Crown, Edco, Wyco, Bomag, Laymor, EZ Trench, Bil-Jax, F.S. Curtis, Gehl Pavers, Heli, Honda, ICS/PowerGrit, IHI, Partner, Imer, Clipper, MMD, Koshin, Rice, CH&E, General Equipment, Amida, Coleman, NAC, Gradall, Square Shooter, Kent, Stanley, Tamco, Toku, Hatz, Kohler, Robin, Wisconsin, Northrock, Oztec, Toker TK, Rol-Air, APT, Wylie, Ingersoll Rand / Doosan, Innovatech, Con X, Ammann, Mecalac, Makinex, Smith Surface Prep, Small Line, Wanco, Yanmar

No.	Pos.	Description	No.	Pos.	Description
501 37 29-01	M	Flush guard sect.800 right cpl	510 00 71-01	C	Cup spring
501 37 30-01	M	Flush guard sect.800 left cpl.	510 11 15-01	K	Handle holder
501 37 31-01	M	Flushguard sect.1000 right cpl	510 19 56-01	P	OIL transmission 150 0,3l.
501 37 32-01	M	Flush guard sect.1000 left cpl	514 04 33-01	A	Screw K6S 5x6
501 37 33-01	M	Flushguard sect.1240 Right cpl	522 52 51-01	E	Pivoting arm
501 37 34-01	M	Flush guard sect.1240 left Cpl	522 52 52-01	E	Shaft
501 37 52-01	P	Tool kit	522 52 54-01	E	Gear
504 00 50-01	M	Blade guard flush D800 Assy	522 52 58-01	E	Turning knob
504 00 52-01	M	Blade guard flush D1000 Assy	522 52 59-01	E	Gear shift lever
504 00 53-01	M	Blade guard flush D1240 Assy	522 52 61-01	E	Gear case cover
504 10 02-01	J	Scale, angle	522 52 62-01	E	Medial gear
504 10 29-01	P	Tool bag	522 52 63-01	E	Medial shaft
505 11 29-01	K	Mount	522 52 64-01	E	Interlayer
505 11 30-01	K	Excentric	522 53 68-01	D	Plug
505 11 31-01	K	Handle bracket	522 71 01-01	B	Grommet
505 11 33-01	K	Beam	522 72 01-01	E	Gasket
505 11 34-01	K	Snap locking	522 73 40-01	L	Outer side 800mm LEFT compl
505 11 35-01	K	Hook	522 73 41-01	L	Outer side 800mm RIGHT compl
505 11 38-01	K	Handle	522 73 43-01	L	Centre section 800mm compl
505 11 39-01	K	Shaft seat	522 73 44-01	L	Outer side 1000mm LEFT compl
505 11 40-01	K	Spring	522 73 45-01	L	Outer side 1000mm RIGHT cpl
505 11 40-01	K	Spring	522 73 47-01	L	Centre section 1000mm compl
505 11 53-01	Q	Hose	522 73 48-01	L	Outer side 1240mm LEFT compl
505 11 58-01	C	Motor assy Track feeding	522 73 49-01	L	Outer side 1240mm RIGHT cpl
505 11 59-01	C	Motor assy Arm feeding	522 73 51-01	L	Centre section 1240mm compl
505 11 99-01	L	Tube	522 78 60-01	A	Outer tube
505 12 00-01	L	Bracket	522 83 94-01	A	Bearing
505 12 02-01	L	Cone	522 83 95-01	A	Bearing
505 12 03-01	L	Cone	522 93 08-01	B	Contact pin 0,75mm ²
505 12 04-01	L	Shaft	525 45 52-01	P	Allen key kit
505 12 05-01	L	Locking plate	525 58 48-01	E	Bearing 6000-2RSL
505 12 06-01	L	Locking plate	525 58 50-01	E	Bearing 6201-2RSL
505 12 07-01	L	Locking stop	525 58 51-01	E	Bearing 16002-2Z
505 12 08-01	L	Locking stop	525 58 52-01	E	Spring
505 12 09-01	L	Cone	525 58 53-01	E	O-ring 25,1x1,6
505 12 10-01	L	Washer	525 58 54-01	E	Radial seal
505 12 59-01	G	Rocker lever	525 58 56-01	E	Stop screw
505 12 60-01	G	Spring	529 28 14-01	E	Bearing cage
505 15 29-01	L	Blade guard D800mm Assy	529 27 88-01	L	Knob
505 15 30-01	L	Blade guard D1000mm Assy	529 28 11-01	E	Lid
505 15 31-01	L	Blade guard D1240mm Assy	529 28 12-01	E	Cover plate
505 18 64-01	K	Parallell pin	529 28 17-01	E	Cover
505 18 65-01	K	Screw	529 28 20-01	E	Stub gear
505 18 66-01	K	Stop screw	531 11 30-45	H	Track section 1,2 m
505 18 74-01	K	Blade guard guide	531 11 30-46	H	Track section 2,0 m
505 21 63-01	F	Radial seal 60x72x4	531 11 30-47	H	Track section 2,2 m
505 21 65-01	F	Lock ring SGA 50	531 11 32-00	J	Mounting bracket universal Cpl
505 21 82-01	Q	Hose 1m	531 11 32-46	H	Mounting bracket WS 400
505 21 83-01	Q	Hose 8m	531 11 32-47	H	Coupling link compl.
505 21 84-01	Q	Hose	531 11 32-48	H	Track holder compl.
505 22 69-01	G	Carriage WS 400	531 11 32-58	G	Guide wheel conc., compl.
505 24 66-01	A	O-ring	531 11 32-59	G	Guide wheel exc., compl.
505 24 70-01	B	Shackle	531 11 32-65	J	Measure rod compl.WS 400 serie
505 24 72-01	E	GEAR ASSY	531 11 32-68	Q	Cleaning brush with hose
505 25 52-01	G	Paralel pin 4x32	531 11 32-71	D	Clutch trackfeeding complete
505 25 54-01	C	Gear box depth feed ASSY	531 11 73-20	B	Contact pin 2,5mm ²
505 25 55-01	C	Gear box track feed ASSY	531 11 81-13	E	Magnetic plug
505 40 03-08	E	Spring	531 11 81-20	E	Coupling
505 50 58-01	B	Drain plug	531 11 82-18	FQ	Quick coupling, male 13411 M
505 52 84-01	A	Ventilating valve	531 11 82-19	AQ	Quick coupling, female 1300 UV
505 52 89-01	B	Frame	531 11 82-90	A	Coupling
505 52 92-01	B	Contact housing	531 11 83-05	Q	Banjo screw
505 53 80-01	A	Quick coupling	531 11 83-18	Q	Waterhose black 1/2
505 53 81-01	B	Console 3-pin	531 11 83-25	Q	Hose nipple 1312
505 53 86-01	C	Motor	531 11 83-56	A	Adaptor 1/4"-1/4"
505 53 88-01	C	Motor cover	531 11 90-15	Q	Hose clamp 15-24
505 53 92-01	B	Console 6-pin	531 11 90-39	D	Bearing washer AS 3552
505 53 93-01	B	Console 6-pin	531 11 90-42	D	Bearing AXK 3552
505 55 56-01	A	Plastic plug	531 11 90-63	A	Grease nipple
506 06 85-01	E	Screw	531 11 90-65	P	Wrench 18 mm

No.	Pos.	Description	No.	Pos.	Description
531 11 91-08	P	Grease gun	531 12 20-44	H	Guide track section 1,2m
531 11 91-37	B	Seal strip	531 12 20-70	H	Safety stop
531 11 91-46	CG	Bearing washer	531 12 21-18	H	Clamping washer
531 11 91-49	CG	Bearing AXK 1024	531 12 21-24	H	Gear rack 2,2 m
531 11 91-50	C	Bearing	531 12 21-25	H	Guide track section 2,2 m
531 11 91-52	H	Rubber plug GL16	531 12 21-68	N	Guide, outer
531 11 91-55	C	Bearing NK 19/16	531 12 21-82	K	Guide wheel shaft, upper
531 11 91-58	C	Shim 23.35x1	531 12 21-83	K	Wheel
531 11 91-65	LM	Blind rivet 4x12 st/st	531 12 22-43	M	Locking feather Right
531 11 91-81	K	Washer 10.5x22	531 12 22-44	M	Locking feather left
531 11 91-83	EHJ	Washer 13x24x2	531 12 22-45	M	Lock cone
531 11 92-02	FH	Screw M6S 12x25	531 12 22-60	M	Top holder
531 11 92-03	HJ	Screw M6S 12x30	531 12 22-80	D	Friction plate pivoting arm
531 11 92-18	M	Screw M6S 8x25	531 12 23-38	K	Spacer
531 11 92-28	C	Screw MC6S 5x14	531 12 23-45	L	Splash guard compl.
531 11 92-35	H	Screw MC6S 8x14	531 12 23-49	L	Splash shield
531 11 92-49	A	Nut M6 cap	531 12 23-57	J	Friction plate
531 11 92-60	L	Washer 5x19x1	531 12 23-58	K	Guide wheel shaft, lower
531 11 92-74	E	O-ring 29,2x3	531 12 23-85	N	Bar to bladeguard
531 11 92-77	C	O-ring 31,4x1,6	531 12 23-88	N	Cramp
531 11 92-82	C	O-ring 44,17x1,78	531 12 23-90	N	Guide Plate
531 11 92-93	A	O-ring 80x1,6	531 12 24-54	J	Mounting bracket
531 11 92-93	B	O-ring	531 12 24-55	J	Shaft
531 11 93-02	C	Key 4x4x16	531 12 24-56	J	Link to spring-holder
531 11 93-26	N	Washer	531 12 24-57	J	Track-holder
531 11 93-50	H	Screw MF6S 4x12 12.9	531 12 24-58	J	Clamping-plate
531 11 93-53	M	Screw MLC6S 6x12	531 12 24-59	J	Clamping-plate, nut
531 11 93-60	E	O-ring 133,0x1,78	531 12 24-60	J	Brake plate
531 11 93-64	EJ	Spring 2547	531 12 30-01	G	Saw carriage
531 11 93-66	E	Ball 4mm	531 12 30-02	G	Socket
531 11 93-75	D	X-Ring 114,0x1,78	531 12 30-03	G	Holder right
531 11 93-76	D	O-Ring 94,97x1,78	531 12 30-04	G	Holder left
531 11 93-89	G	Screw MLC6S 5x10	531 12 30-05	G	Concentric shaft
531 11 94-13	LM	Handle Bladeguard	531 12 30-06	G	Excentric shaft
531 11 94-20	J	O-ring 40x2	531 12 30-08	G	Nut for guidewheels
531 11 94-26	GMN	Screw K6S 6x16 10.9 fzb	531 12 30-09	G	Handle
531 11 94-35	N	Edge list 3,3 Meter	531 12 30-10	G	Bar
531 11 94-39	D	Bearing HK 3520	531 12 30-11	G	Excentric locking shaft
531 11 94-40	D	Bearing washer AS 5070	531 12 30-12	G	Locking clamp
531 11 94-42	G	Bearing 6001-2RSH	531 12 30-13	G	Sprint
531 11 94-43	D	Bearing 16007	531 12 30-15	G	Feeding shaft
531 11 94-46	C	Bearing washer AS 1528	531 12 30-16	G	Shaft holder
531 11 94-51	E	O-ring 74,5x3	531 12 30-17	G	Transfer gear
531 11 94-53	G	Levell	531 12 30-18	G	Nut for shaft
531 11 94-54	G	Spring	531 12 30-20	A	Wear plate
531 11 94-63	E	Cylindrical pin	531 12 30-21	D	Feeding gear, arm
531 11 94-56	H	Turning knob	531 12 30-22	D	Feeding gear, track
531 11 95-00	D	O-ring 61x1,6	531 12 30-23	D	Longitudinal feeding gear
531 11 95-04	D	O-ring 71,12x2,62	531 12 30-24	D	Tensioning nut
531 11 95-10	B	Screw K6S 6x10	531 12 30-25	D	Cup spring
531 11 95-11	A	Screw K6S 8x16 10.9 fzb	531 12 30-26	D	Friction plate
531 11 95-17	F	Plug for M8	531 12 30-28	C	Feeding screw
531 11 95-26	M	Edge list 3,3 Meter WS 400	531 12 30-33	F	Flange, outer
531 11 95-31	P	Water level to toolkit	531 12 30-35	E	Blade shaft
531 11 95-32	P	Ratchet wrench to toolkit	531 12 30-48	F	60mm bushing
531 11 95-33	P	Wrench 16mm to toolkit	531 12 30-51	F	Plate for hub
531 11 95-34	P	Socket 18mm to toolkit	531 12 30-55	C	Cover plate
531 11 95-41	P	Socket 19mm to toolkit	531 12 30-57	F	Water connection
531 11 95-42	A	Screw K6S 6x40 10.9 fzb	531 12 30-59	LM	Rail holder
531 11 95-53	Q	Cleaning brush	531 12 30-63	LM	Rail
531 11 95-79	C	Screw	531 12 30-65	K	Holder
531 11 95-86	J	Screw MRX M3x5	531 12 30-66	K	Cover
531 11 95-88	G	Seeger circlip SGA 11	531 12 30-70	K	Handle
531 11 95-89	K	Screw K6S 6x20 10.9 fzb	531 12 30-71	K	Excentric shaft
531 11 95-93	F	Plug for M10	531 12 30-73	LM	Slide rail
531 12 16-11	M	Hand wheel	531 12 30-74	P	Pin socket
531 12 20-27	H	Gear rack 2,0m	531 12 30-75	H	Track holder
531 12 20-28	H	Gear rack 1,2m	531 12 30-76	H	Clamping plate
531 12 20-34	C	Thrust journal	531 12 30-86	LM	Rail holder 2
531 12 20-43	H	Guide track section 2,0m	531 12 30-87	N	Handle bladeguard 1240mm

No.	Pos.	Description	No.	Pos.	Description
531 12 30-91	N	Handle	720 13 51-50	EG	Cylindrical pin 6x16
531 12 30-95	F	Water hose	720 13 52-51	H	Cylindrical pin 6x18
531 12 30-96	H	Coupling link	720 13 53-50	J	Cylindrical pin 6x20
531 12 30-97	H	Clamping washer	720 13 65-51	J	Cylindrical pin 6x50
531 12 32-14	A	Mounting plate	721 42 57-00	N	Spring pin 4x22
531 12 32-27	C	Input shaft	723 51 93-51	C	Screw MFS 2,5x8
531 12 32-34	C	Sun gear 166	723 53 66-51	F	Screw MFS 6x12
531 12 32-36	C	Output sun gear 166	725 25 43-51	H	Screw M6S 12x55
531 12 32-81	B	Cover	725 25 44-91	E	Screw M6S 12x60
573 96 27-01	A	Spacing block	725 25 56-51	J	Screw M6S 12x120
573 98 71-01	A	Type plate	725 52 20-01	C	Screw MC6S 3x6
574 26 34-01	A	Spacing sleeve	725 52 89-01	E	Screw MC6S 4x10
574 41 61-01	B	Electronic box top	725 52 93-01	B	Screw MC6S 4x16
574 41 62-01	B	Electronic box	725 53 27-01	A	Screw MC6S 5x12
574 41 64-01	D	Clutch plate	725 53 29-01	E	Screw MC6S M5x16
574 43 13-01	F	Hub	725 53 31-01	C	Screw MC6S 5x20
574 43 55-01	F	Water block	725 53 33-01	A	Screw MC6S 5x25
574 44 39-01	E	Ring	725 53 41-01	K	Screw MC6S 5x50
574 45 18-01	E	Pin	725 53 62-01	K	Screw MC6S 6x8
574 45 20-01	E	Bearing 16013	725 53 64-01	H	Screw MC6S 6x10
574 45 21-01	E	Bearing 16011	725 53 68-01	GKLM	Screw MC6S 6x16
574 45 22-01	E	Radial seal	725 53 70-01	GL	Screw MC6S 6x20
574 45 23-01	F	Radial seal 50x62x5	725 54 51-01	A	Screw MC6S 8x20
574 45 24-01	E	O-ring 45x1,6	725 54 53-01	G	Screw MC6S 8x25
574 45 25-01	F	O-ring 75x2	725 54 64-01	E	Screw MC6S 8x65
574 45 26-01	E	O-ring 91,7x1,78	725 62 87-01	E	Screw MF6S 4x8
574 45 27-01	F	Bearing	725 62 89-01	B	Screw MF6S 4x10
574 45 29-01	E	O-ring 110,7x1,78	725 63 27-51	AFK	Screw MF6S 5x12 10.9
574 45 30-01	E	O-ring 56,87x2,62	725 63 30-51	KL	Screw MF6S 5x16 10.9
574 45 32-01	E	Lock ring	725 63 66-51	AF	Screw MF6S 6x12 10.9
574 45 58-01	E	X-ring 142,47x3,53 NBR	725 63 68-51	AEKLM	Screw MF6S 6x16 10.9
574 45 59-01	B	Seal	725 63 70-51	FKN	Screw MF6S 6x20 10.9
574 45 60-01	B	Seal	725 64 47-51	F	Screw MF6S 8x12 10.9 fzb
574 45 61-01	B	Seal	725 64 89-51	F	Screw MF6S 10x16 10.9
574 47 63-01	A	Seperator	728 72 89-05	D	Stop screw S6SS 4x10
574 61 87-01	D	Arm shaft	728 73 64-05	G	Stop screw S6SS 6x10
574 61 96-01	B	Motor Interface Board	728 83 21-05	A	Stop screw
574 61 97-01	D	Key 6x6x14	728 83 27-05	J	Stop screw
574 64 83-01	E	Gear assy	728 83 27-05	J	Stop screw SK6SS 5x12
574 64 84-01	E	Gear assy	728 83 64-05	G	Stop screw SK6SS 6x10
574 64 85-01	E	Cooling unit	731 43 20-01	GKN	Nut M10 low
574 65 26-01	E	Pivoting arm ASSY	732 25 14-01	K	Nut M5 Nylock
574 65 44-01	A	Motor ASSY	732 25 16-01	N	Nut M6 Nylock
574 82 95-01	F	Blade flange 1" compl.	732 25 22-71	EJ	Nut M12 Nylock 10.9
574 82 95-02	F	Blade flange 60mm compl.	734 11 35-71	G	Washer 4.3x8
574 82 95-03	F	Blade flange 130 compl.	734 11 63-01	EH	Washer 8.4x16
574 83 88-01	B	Sealing holder	735 31 28-10	G	Seeger circlip
574 88 03-01	B	O-ring	735 31 33-00	D	Seeger circlip SGA 35
575 30 39-01	A	Hose	735 31 33-10	K	Seeger circlip SGH 35
575 32 05-01	E	Excenter pin	738 21 10-04	D	Bearing 6010-2RS1
575 33 54-01	B	Cover	738 22 02-24	K	Bearing 6202-2RS1 C2
575 49 11-01	E	Shock absorber	740 38 27-01	AFQ	Sealing ring 1/4
575 49 14-01	E	Screw MC6S 5x100	740 42 07-00	F	O-ring 9,1x1,6
575 49 15-01	E	Rubber piece	740 42 14-00	G	O-ring 16,1x1,6
576 21 49-01	G	Bushing compl.	740 43 07-00	H	O-ring 9,3x2,4
576 65 89-01	J	Screw	740 44 05-00	EF	O-ring 22,2x3
576 65 89-01	J	Support screw			
576 72 06-01	E	Spacer			
576 74 40-01	E	Gear shaft			
577 53 16-01	F	Stop washer			
577 53 22-01	F	Flange, inner			
577 53 28-01	F	Flange, inner 130			
577 53 29-01	F	Screw MC6S 2,5x5			
577 86 60-01	A	Saw handle			
577 88 62-01	A	Spacer			
578 11 32-01	A	Housing			
578 30 03-01	C	HAL sensor board			
578 34 43-01	G	Wheel			
720 12 71-50	G	Cylindrical pin 4x18			
720 13 08-50	EG	Cylindrical pin 5x16			

A WS 482 HF

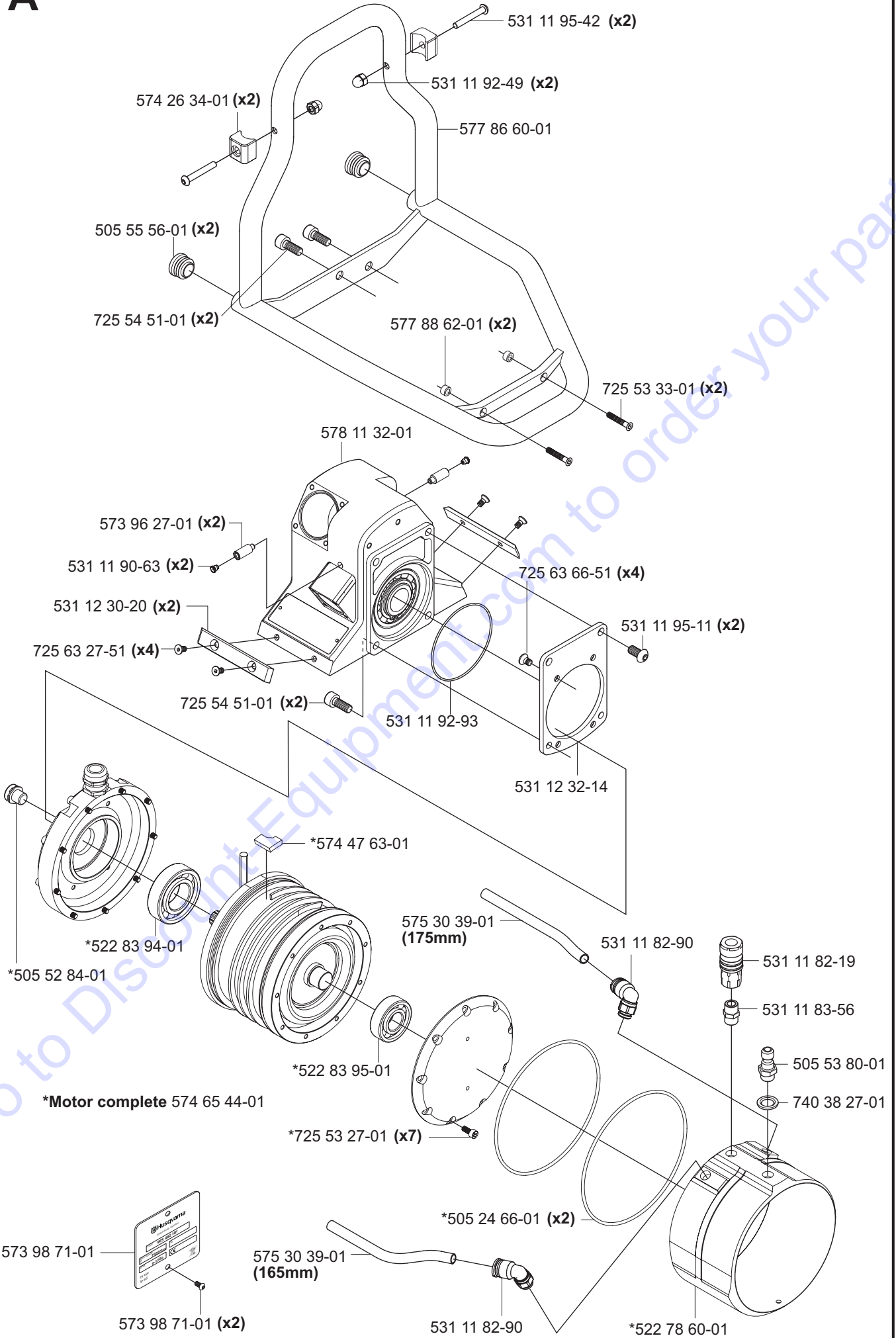

B WS 482 HF

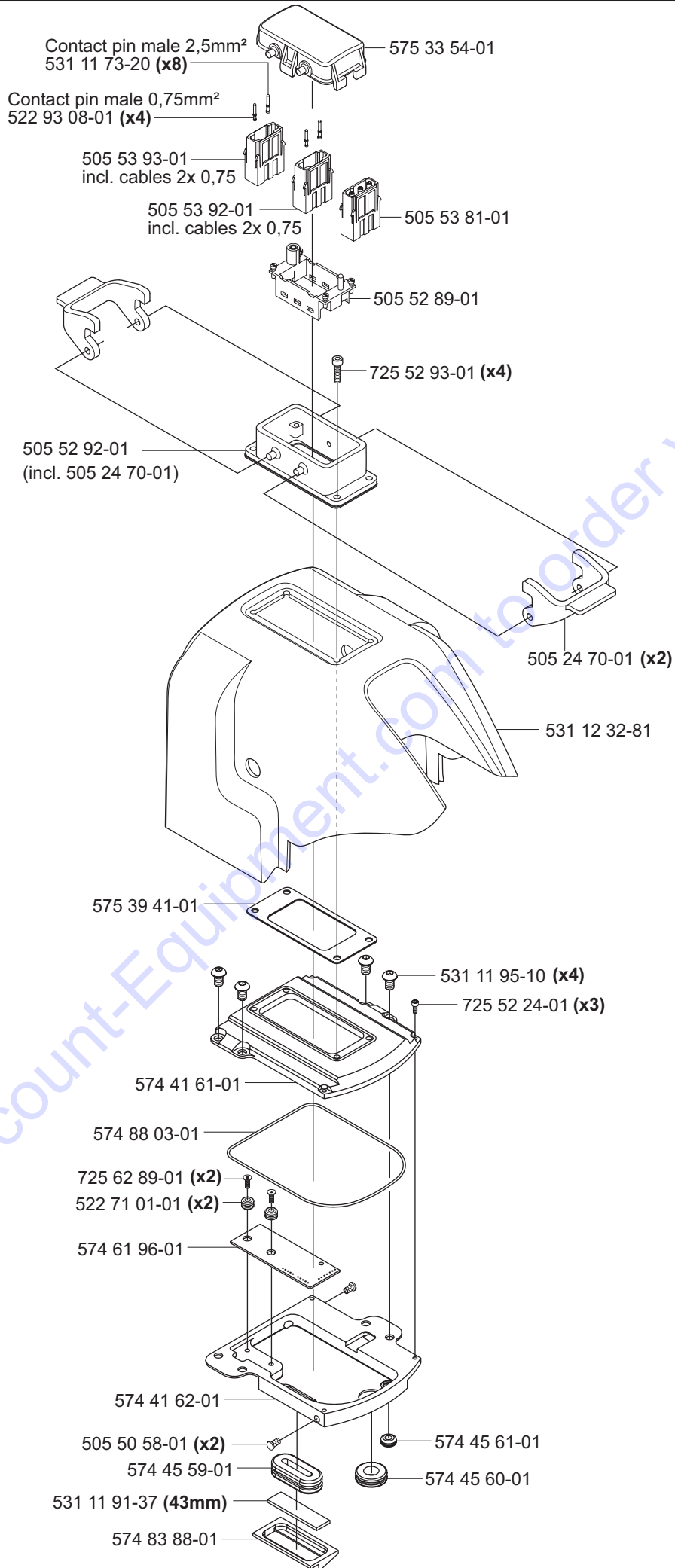

C WS 482 HF

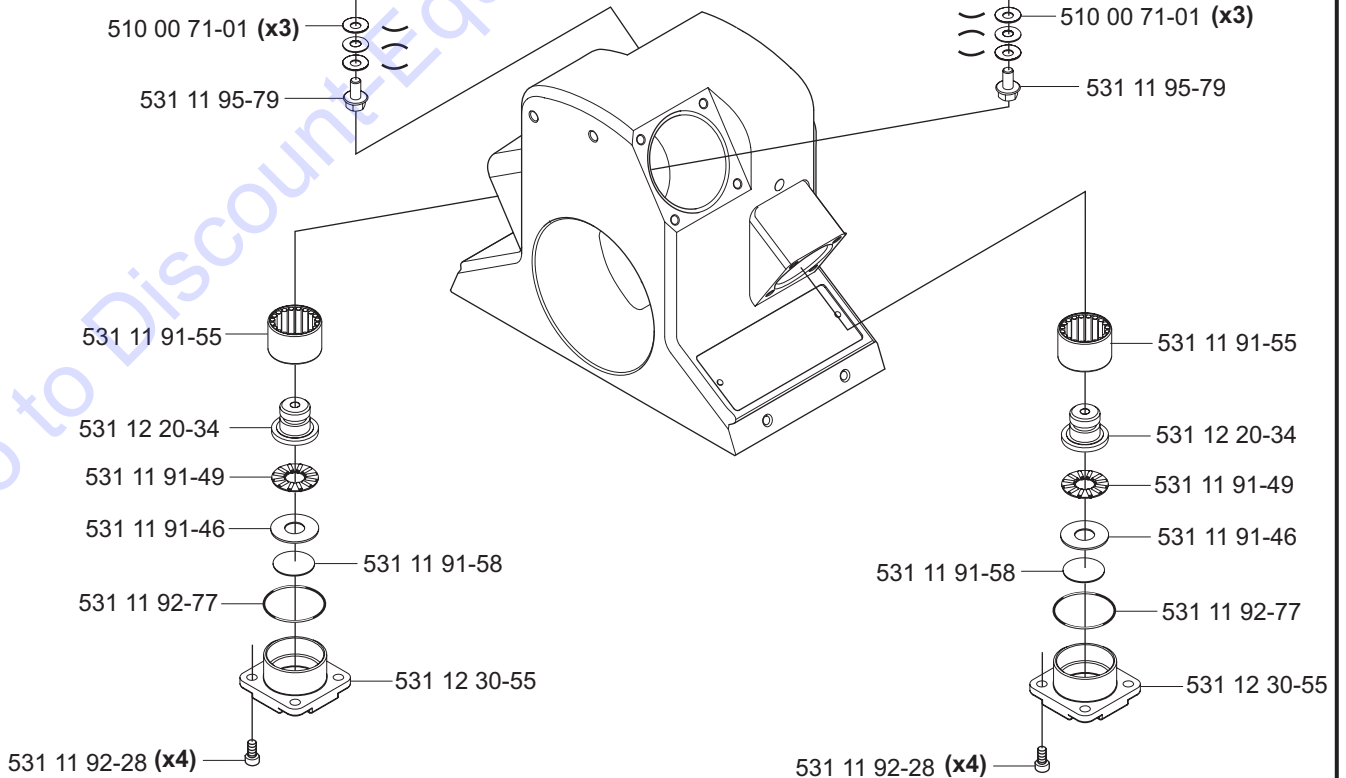
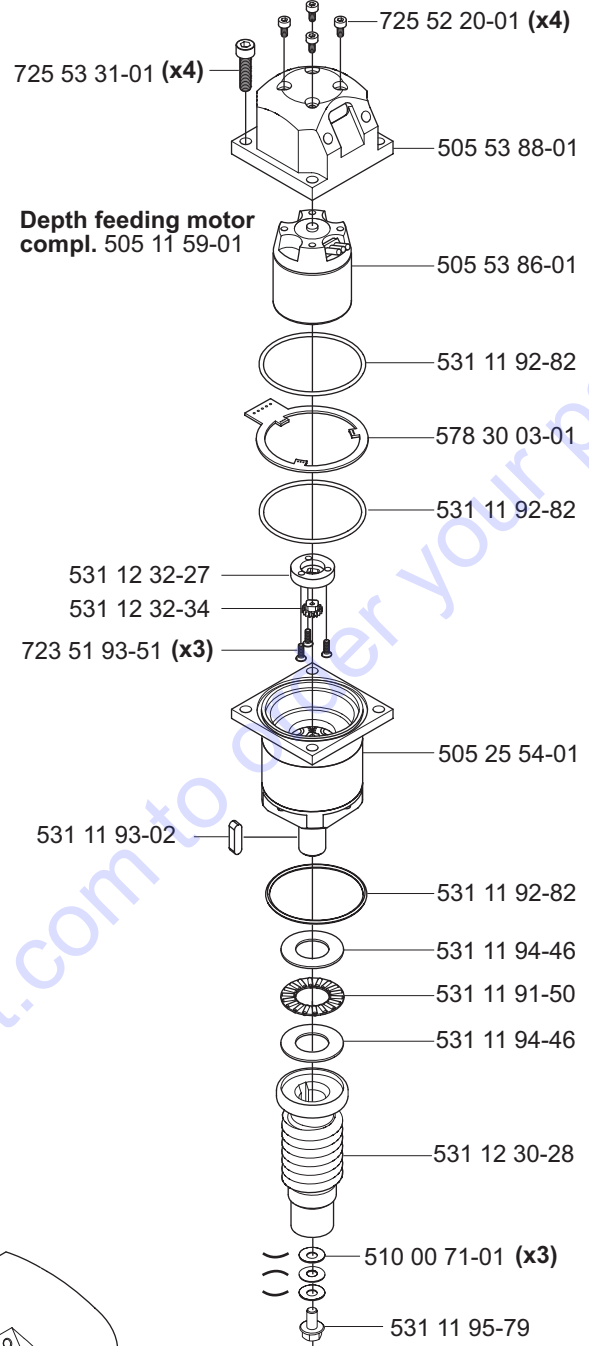
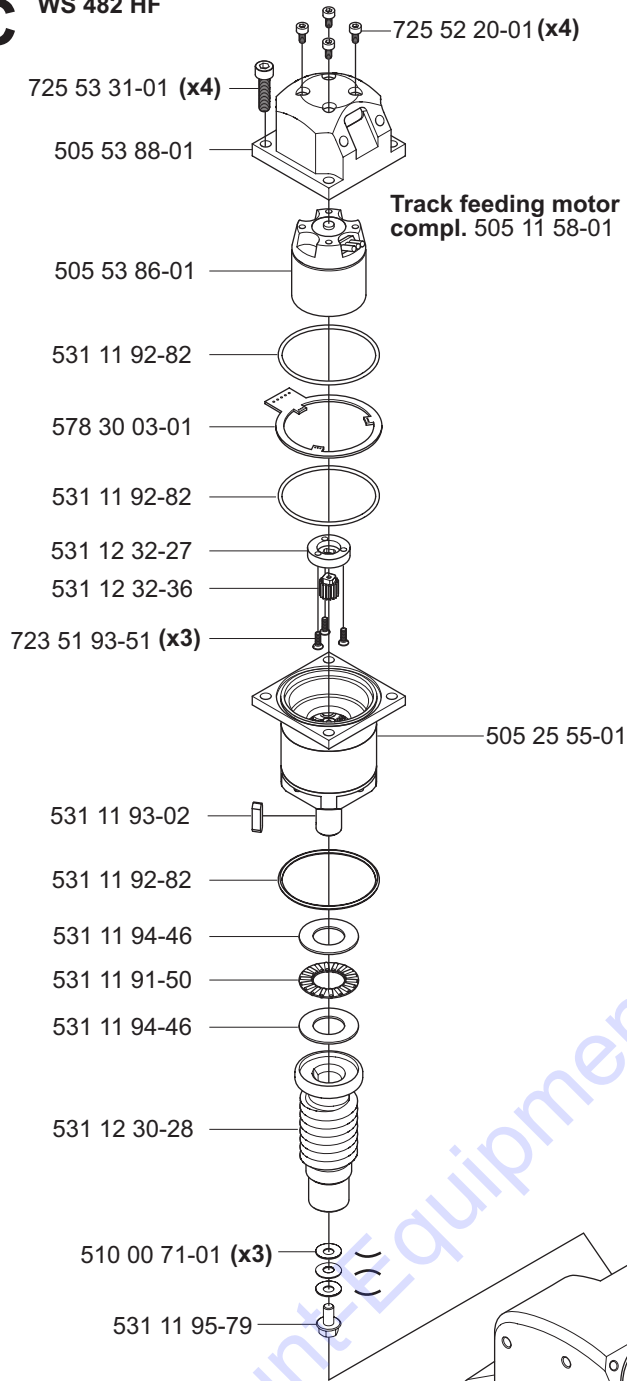

D WS 482 HF

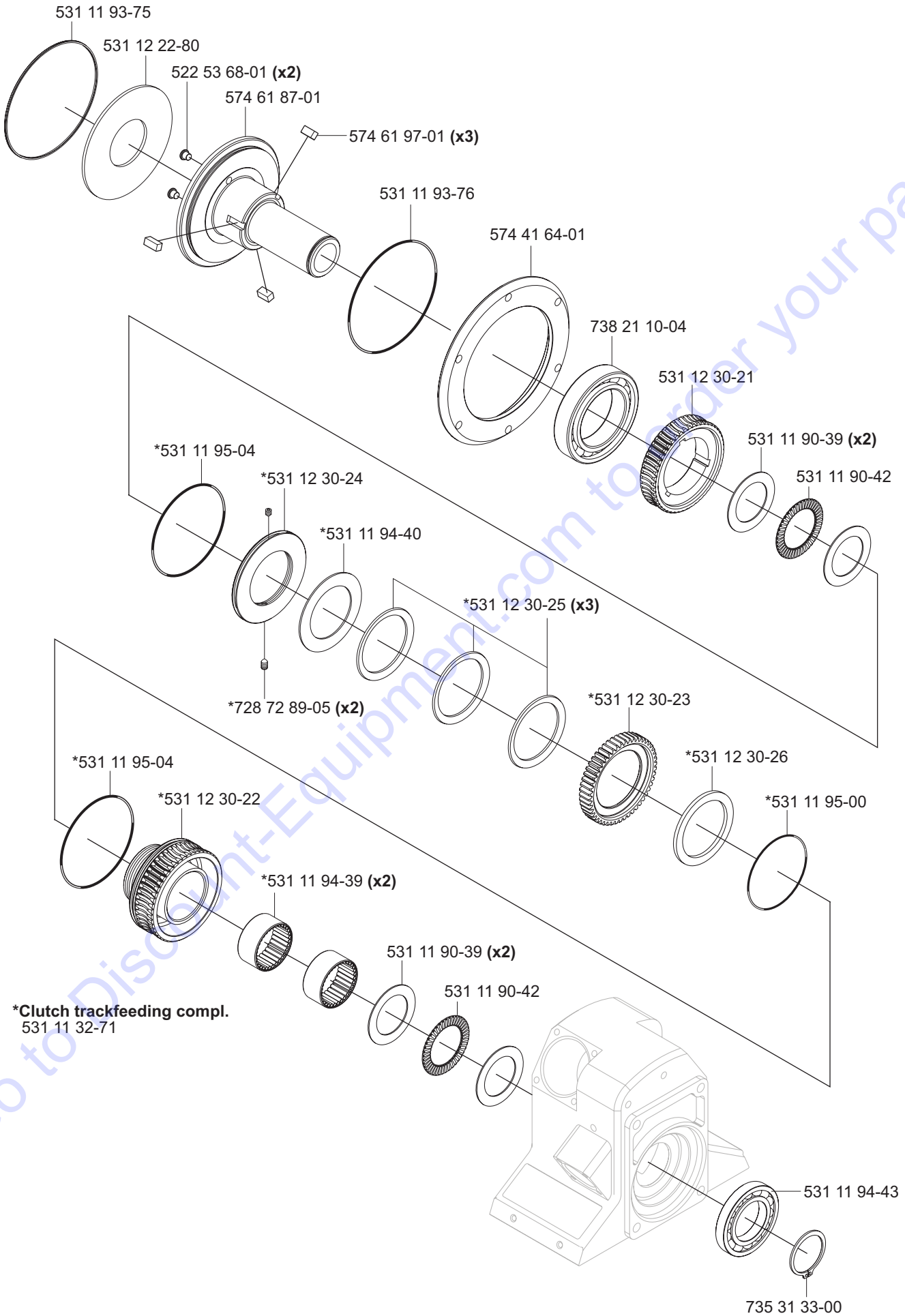

E WS 482 HF

Pivoting arm complete
574 65 26-01

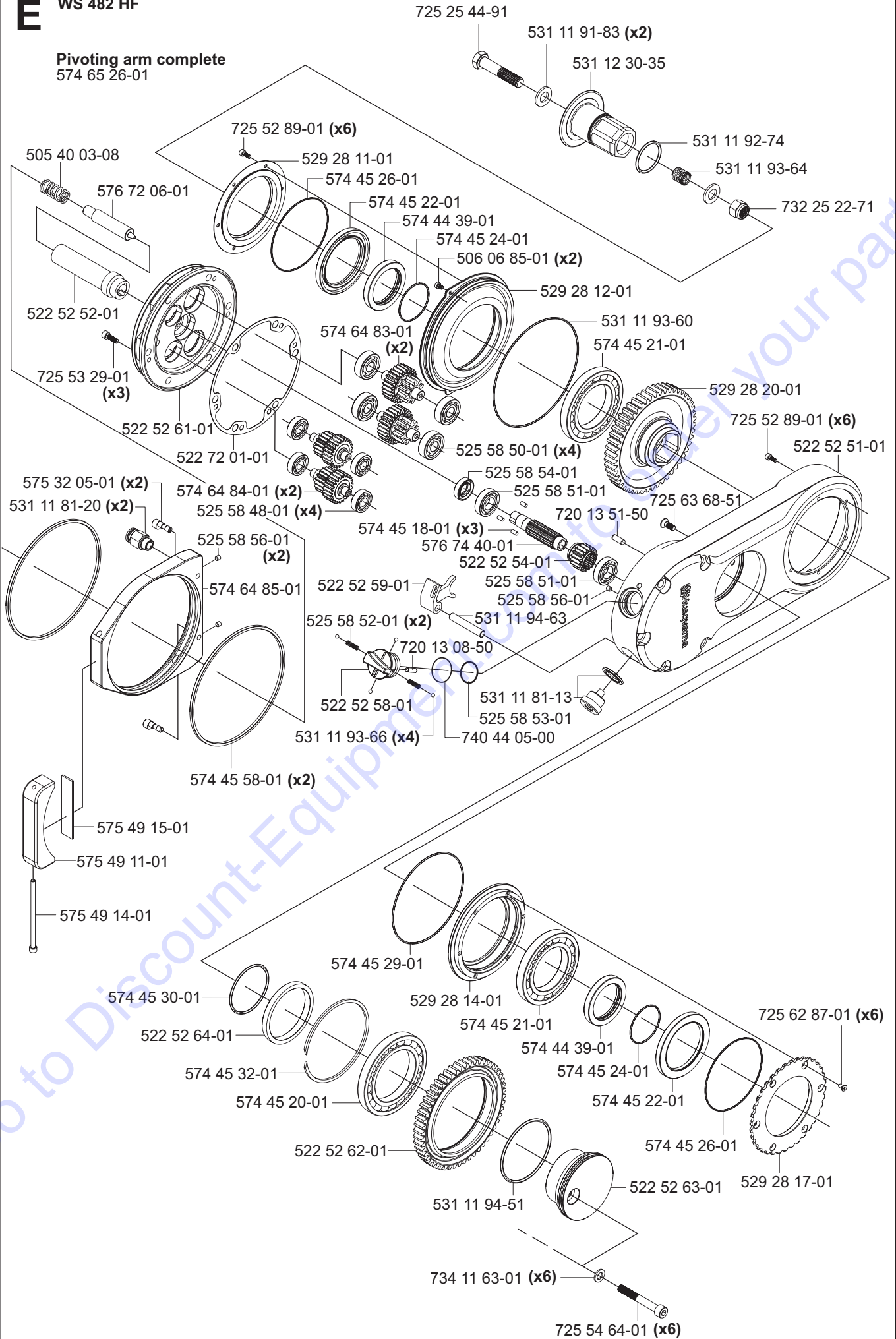

F WS 482 HF

- Flange 1" complete 574 82 95-01
- Flange 60mm complete 574 82 95-02
- Flange 130 complete 574 82 95-03

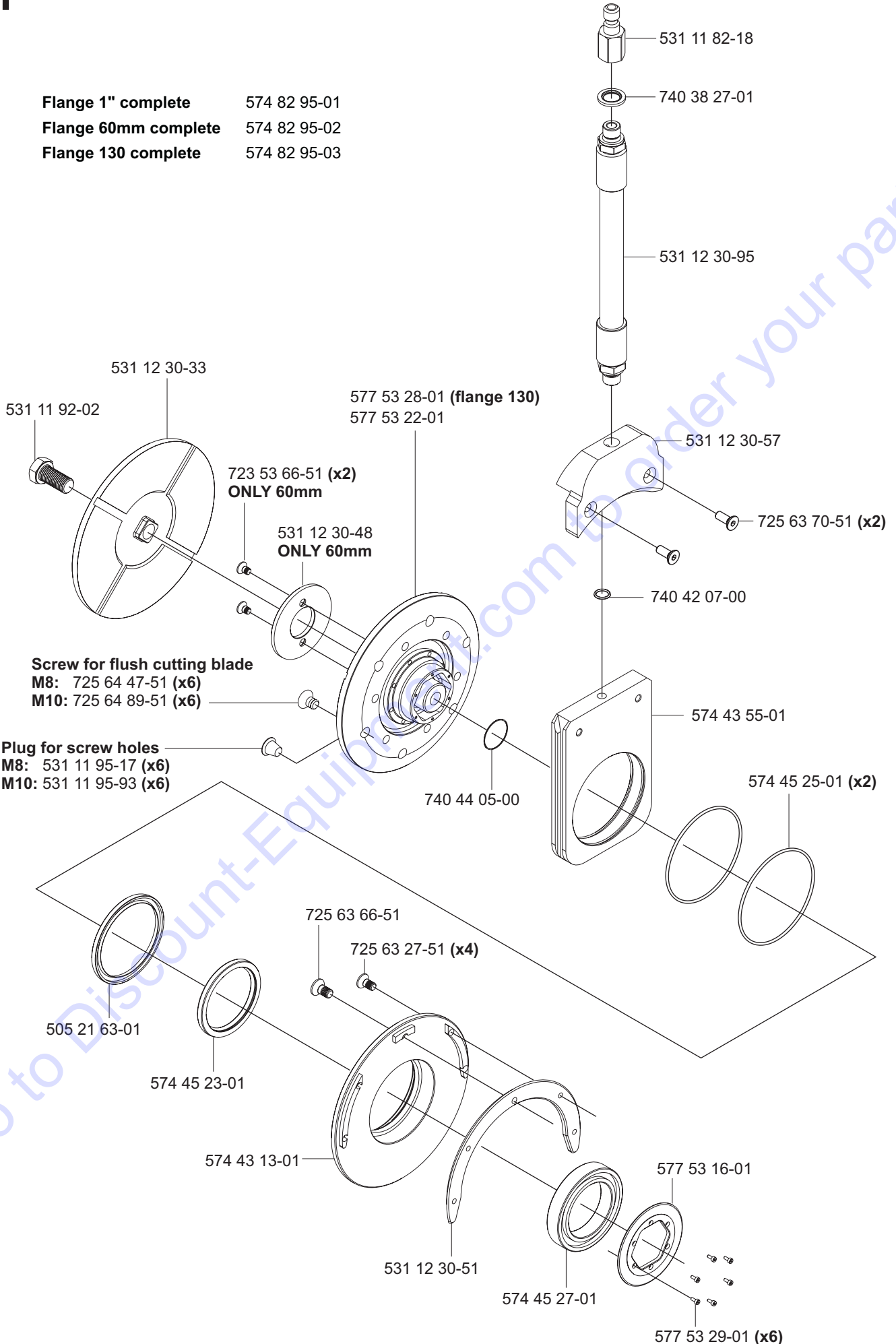



WS 482 HF

Saw carriage 400 complete 505 22 69-01

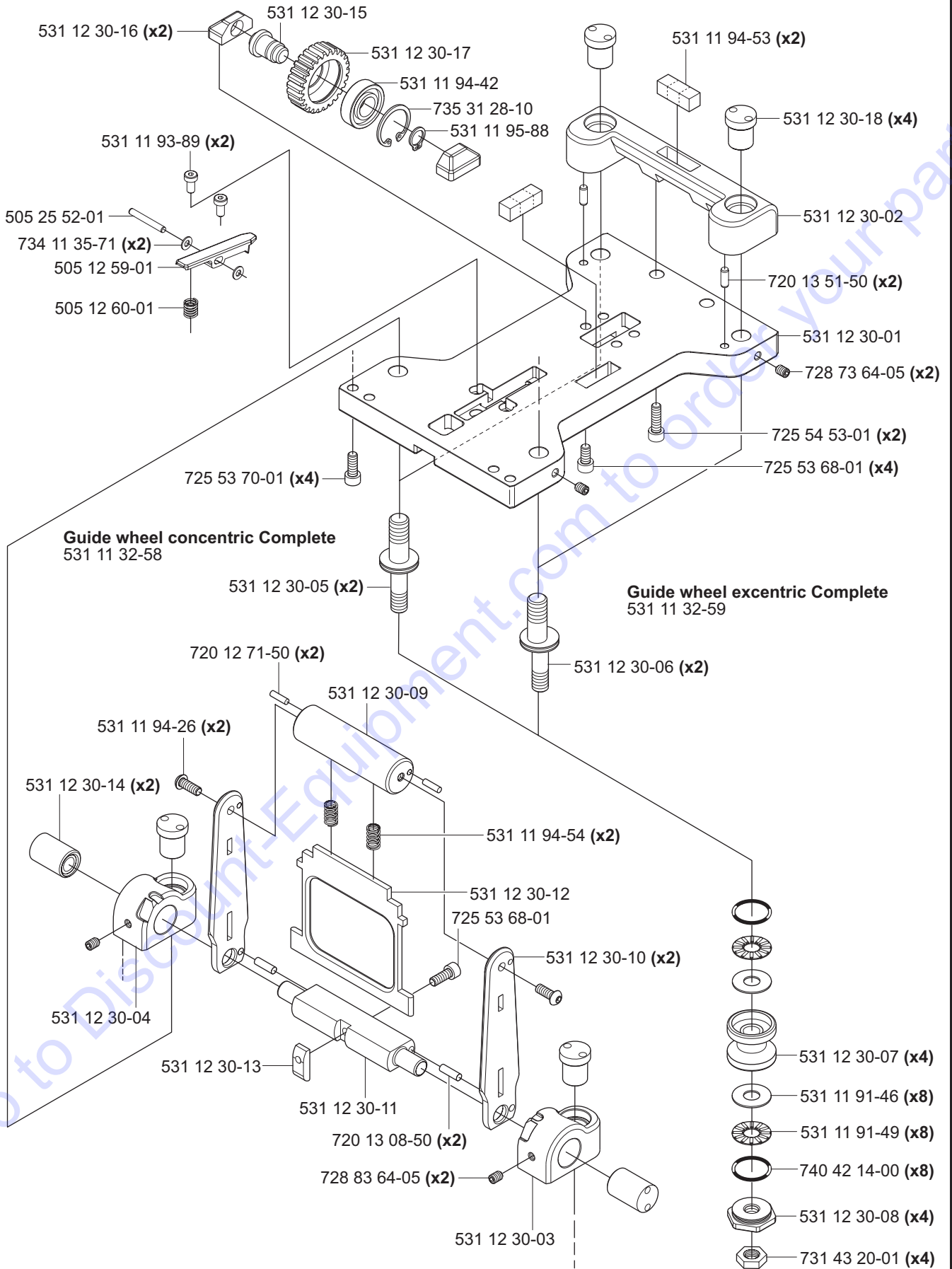

H WS 482 HF

Track 400 complete

1.2m 531 11 30-45

2.0m 531 11 30-46

2.2m 531 11 30-47

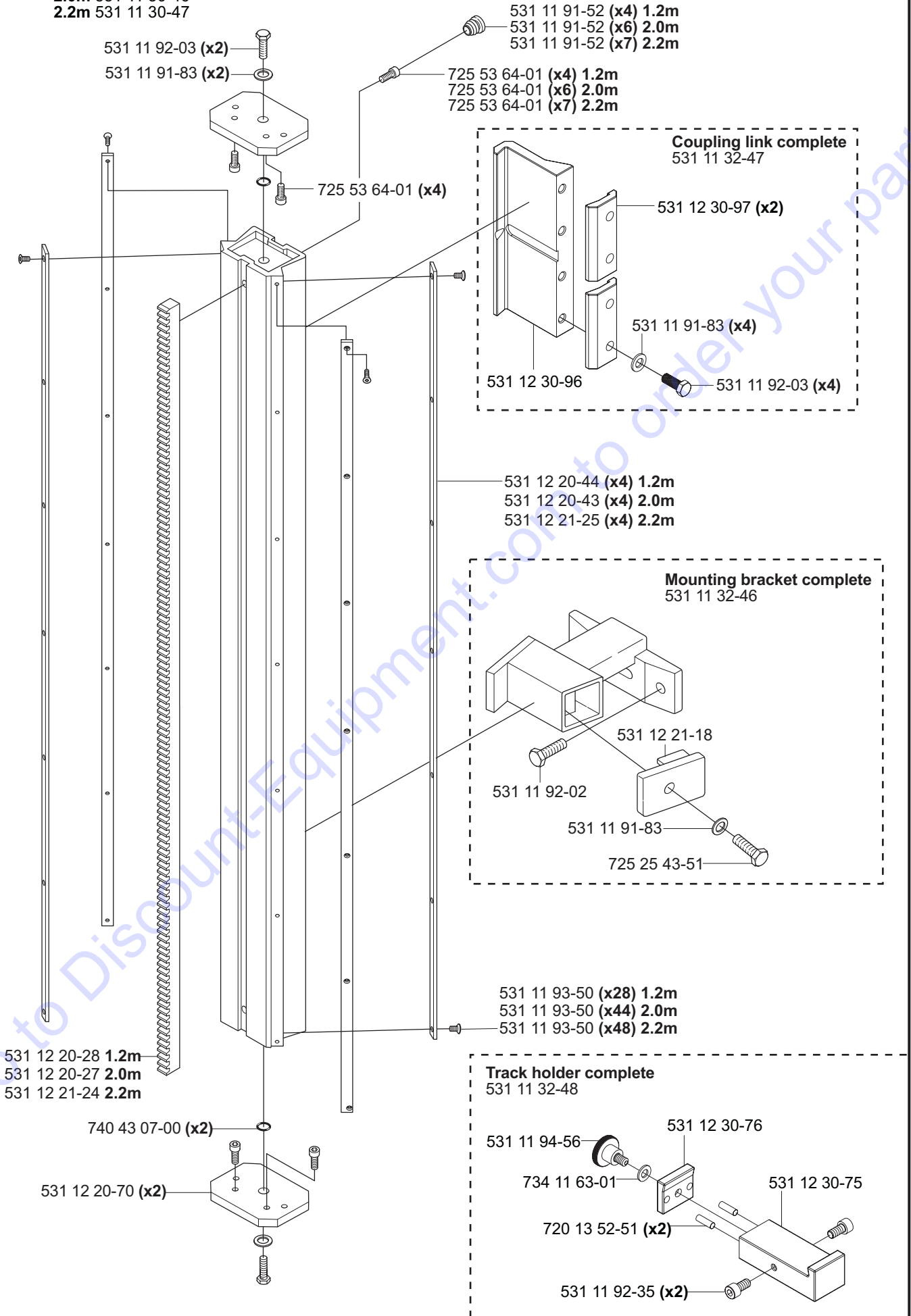

J**WS 482 HF**

Tillbehör
 Accessories
 Zubehöre
 Accessoires
 Accesorios

**Mounting bracket Universal
 compl. 531 11 32-00**

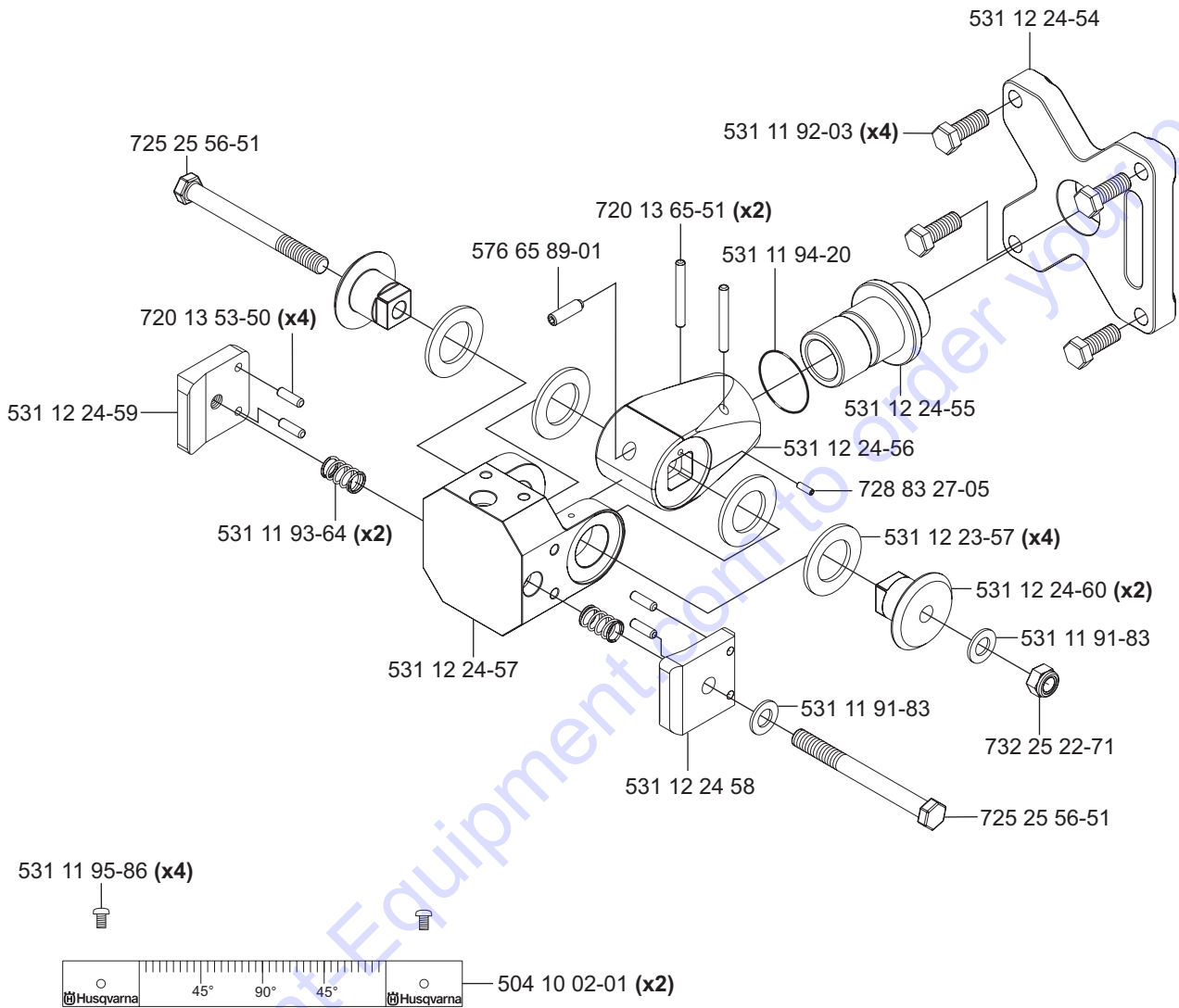

Measure rod complete 531 11 32-65

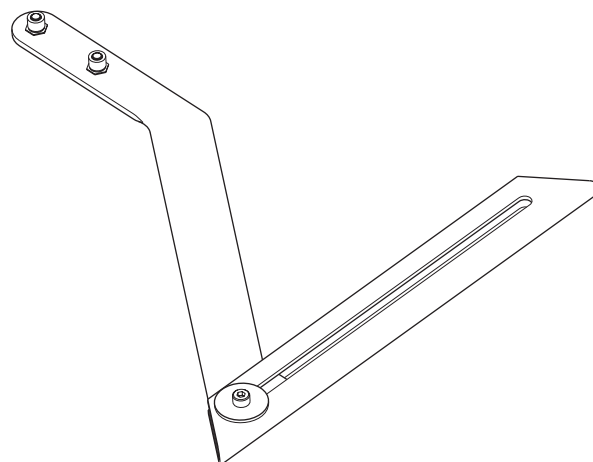

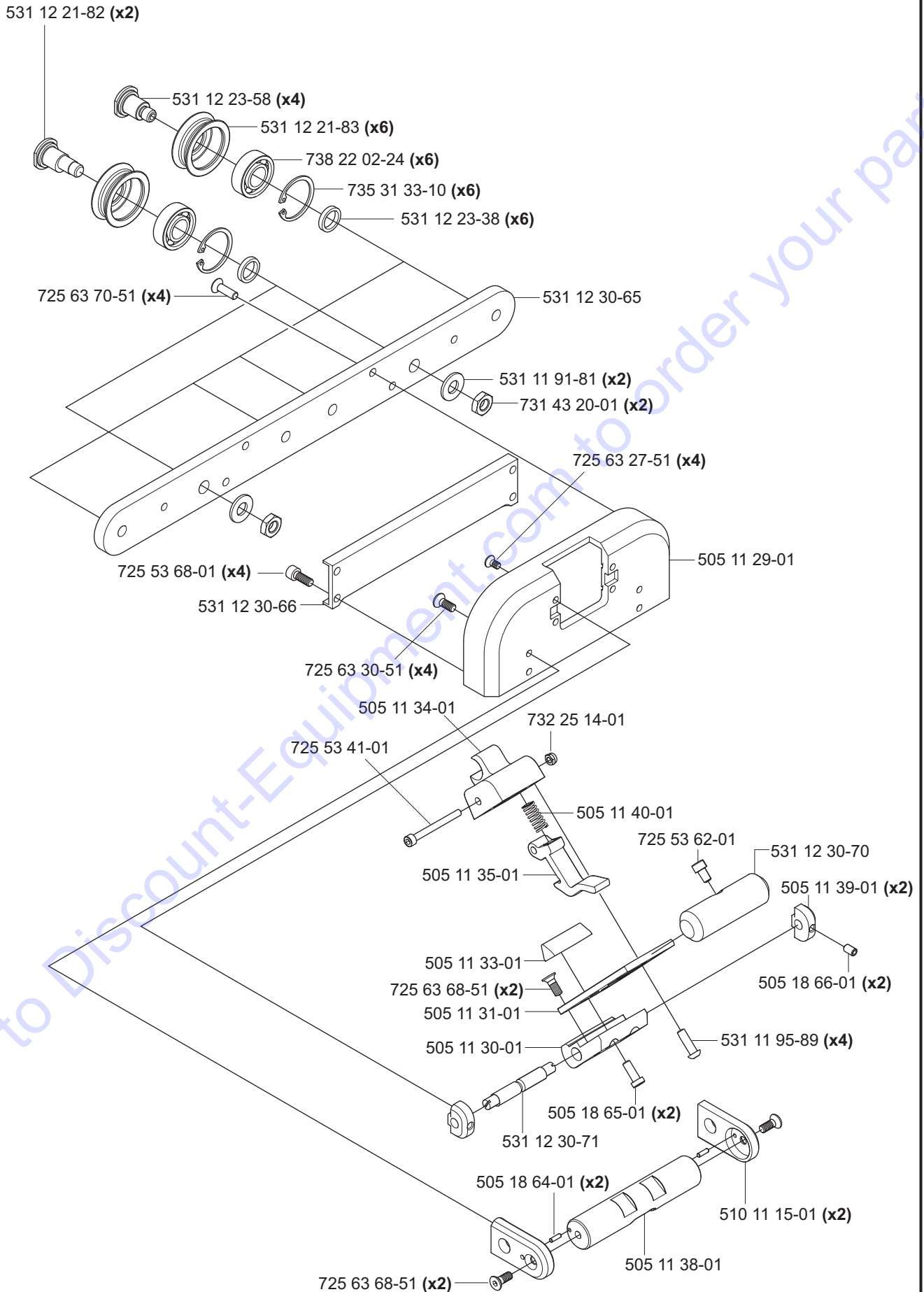
K**WS 482 HF****Blade guard guide Complete 505 18 74-01**

L

WS 482 HF

Blade guard Complete

- 800mm 505 15 29-01 725 53 68-01(x2)
- 1000mm 505 15 30-01
- 1240mm 505 15 31-01

Outer side, RIGHT compl.

- 800mm 522 73 41-01
- 1000mm 522 73 45-01
- 1240mm 522 73 49-01

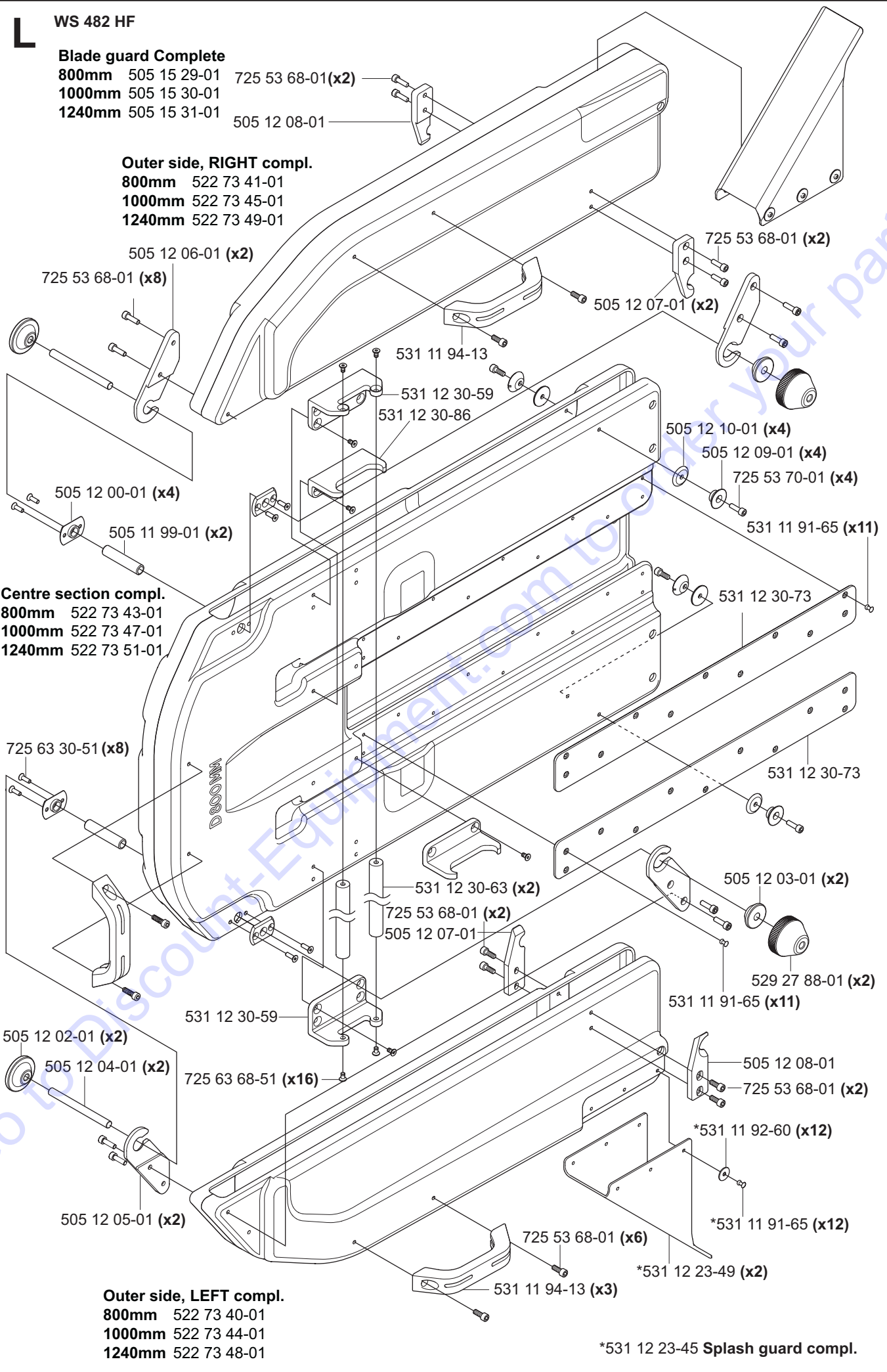

- Centre section compl.**
- 800mm 522 73 43-01
 - 1000mm 522 73 47-01
 - 1240mm 522 73 51-01

- Outer side, LEFT compl.**
- 800mm 522 73 40-01
 - 1000mm 522 73 44-01
 - 1240mm 522 73 48-01

*531 12 23-45 Splash guard compl.

M WS 482 HF

Flush blade guard compl.

- 800mm 504 00 50-01
- 1000mm 504 00 52-01
- 1240mm 504 00 53-01

Outer side, right compl.

- 800mm 501 37 29-01
- 1000mm 501 37 31-01
- 1240mm 501 37 33-01

Edge list 3,3 Meter

531 11 95-26

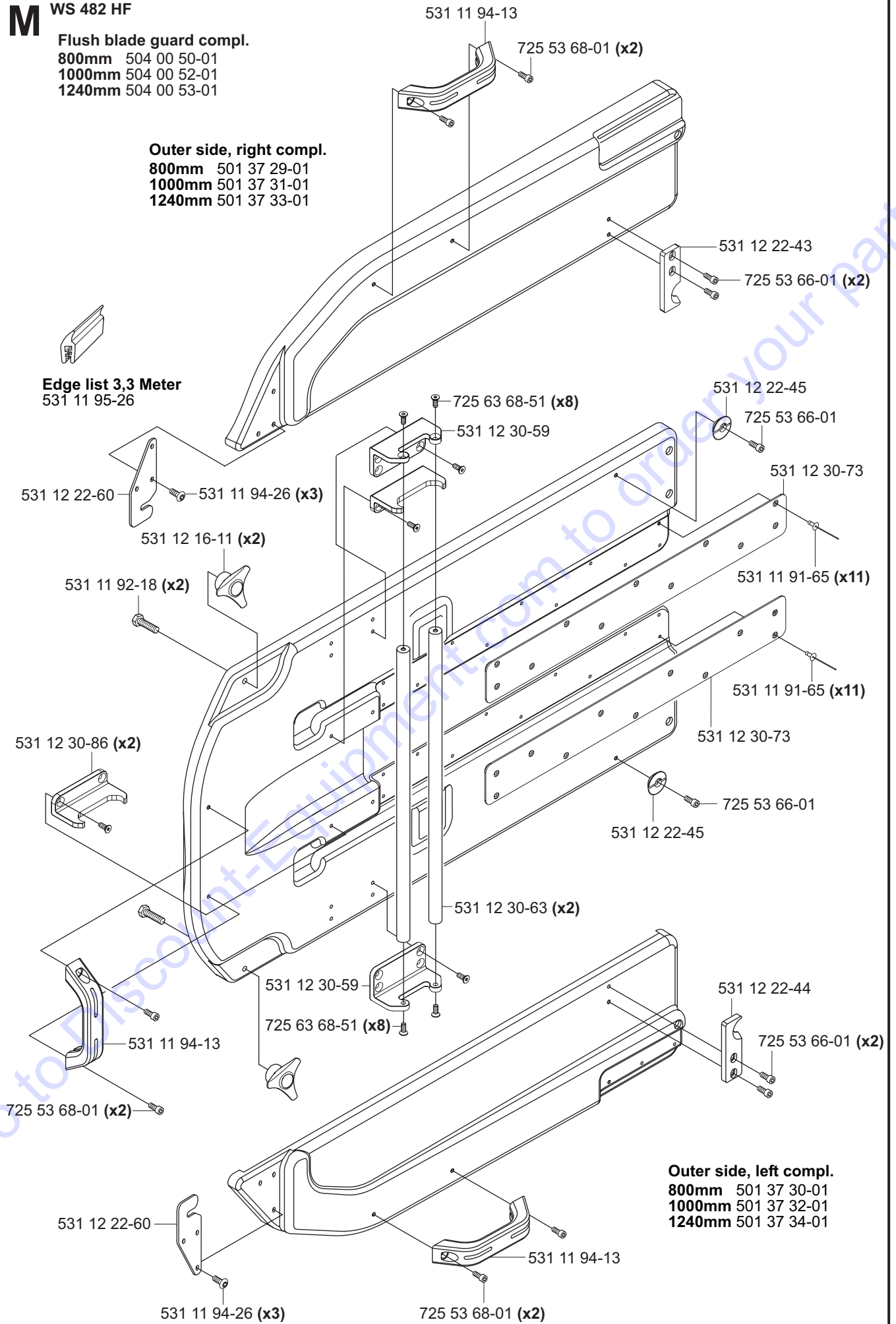

Outer side, left compl.

- 800mm 501 37 30-01
- 1000mm 501 37 32-01
- 1240mm 501 37 34-01

N

WS 482 HF

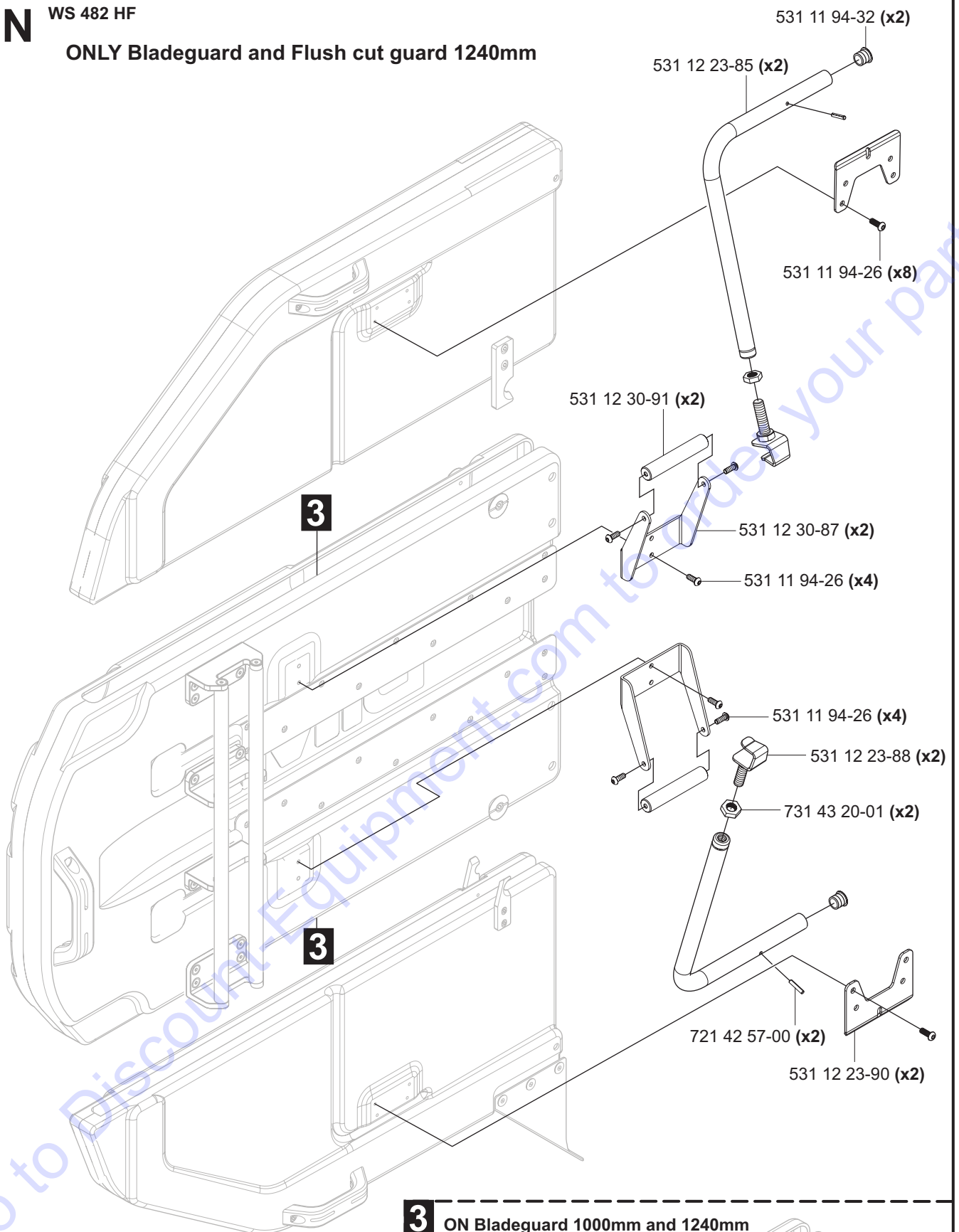
ONLY Bladeguard and Flush cut guard 1240mm**3****ON Bladeguard 1000mm and 1240mm**

732 25 16-01 (x2)

531 11 93-26 (x2)

531 12 21-68 (x2)

725 63 70-51 (x2)

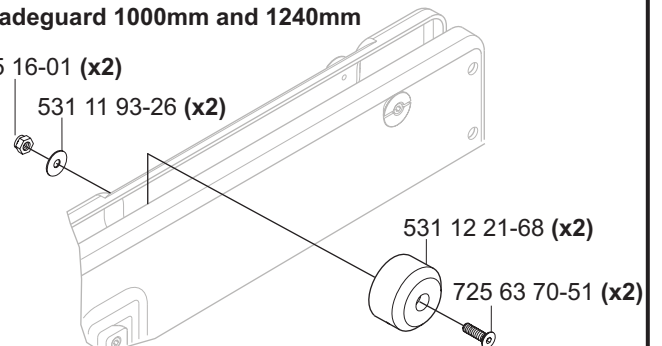

P

WS 482 HF

Toolkit compl 501 37 52-01

504 10 29-01

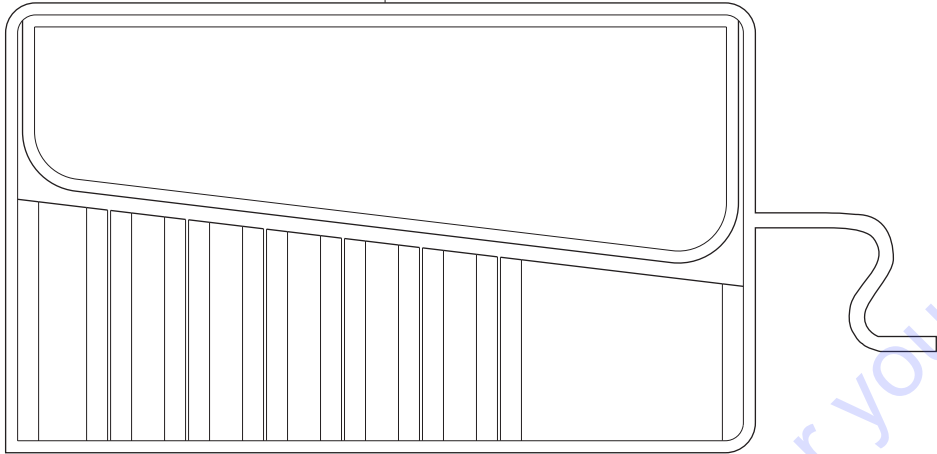

531 11 95-31

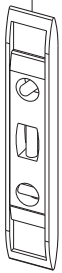

531 11 95-32



531 11 90-65

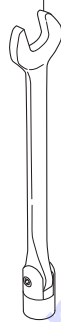

18mm

531 11 95-33



16mm

531 11 95-41



19mm

531 11 95-34



18mm

531 12 30-74



525 45 52-01

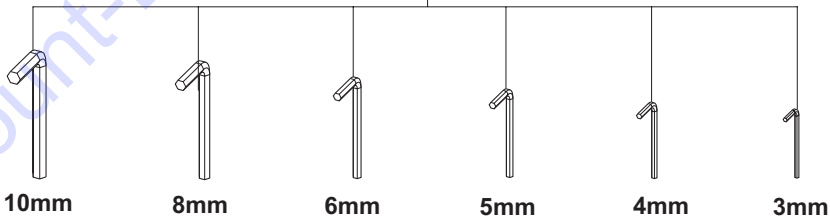

10mm

8mm

6mm

5mm

4mm

3mm

510 19 56-01



531 11 91-08



Q

WS 482 HF

Water hose 8m 505 11 53-01

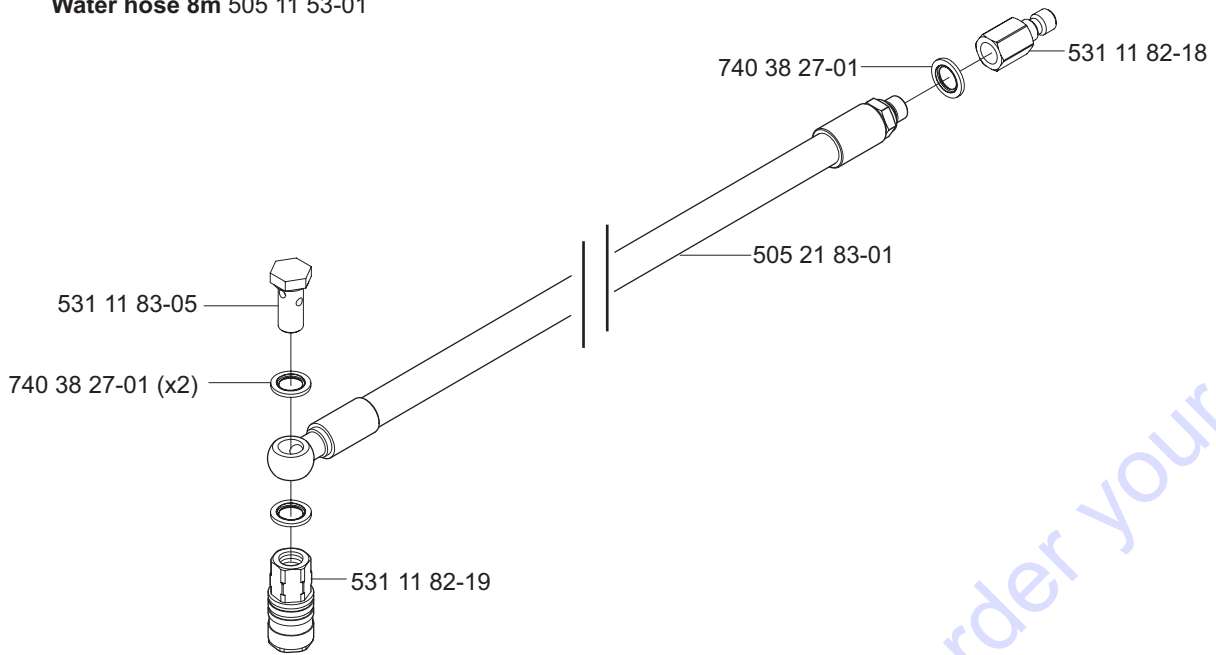

Water hose 1m 505 21 84-01

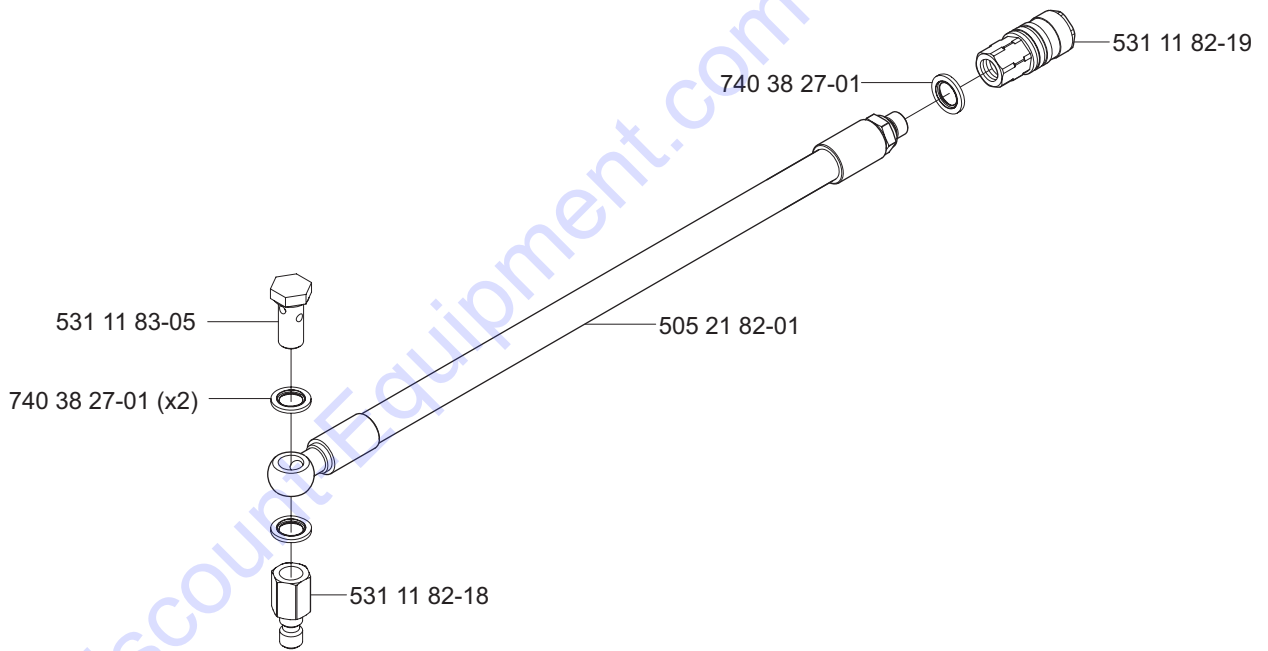

Cleaning brush complete 531 11 32-68

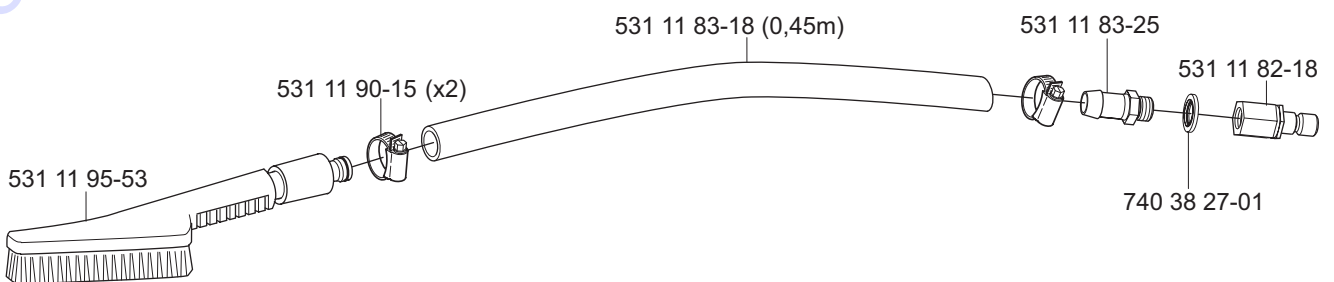

PARTS FINDER

**Search Website
by Part Number**



**Search Manual
Library For Parts
Manual & Lookup Part
Numbers – Purchase
or Request Quote**

Search Manuals

Enter your information to help us find the right parts manual for your machine.

* Brand:

* Model:

* Serial:

* Part Number:

SEARCH

**Can't Find Part or
Manual? Request Help
by Manufacturer,
Model & Description**

Parts Order Form

Please fill in the following information to help us find the right part for your machine.

Manufacturer:	<input type="text"/>
Model:	<input type="text"/>
Description:	<input type="text"/>
Part Number:	<input type="text"/>
Quantity:	<input type="text"/>
Notes:	<input type="text"/>

Discount-Equipment.com is your online resource for quality parts & equipment.

Florida: **561-964-4949** Outside Florida TOLL FREE: **877-690-3101**

Need parts?

Click on this link: <http://www.discount-equipment.com/category/5443-parts/> and choose one of the options to help get the right parts and equipment you are looking for. Please have the machine model and serial number available in order to help us get you the correct parts. If you don't find the part on the website or on one of the online manuals, please fill out the request form and one of our experienced staff members will get back to you with a quote for the right part that your machine needs.

We sell worldwide for the brands: Genie, Terex, JLG, MultiQuip, Mikasa, Essick, Whiteman, Mayco, Toro Stone, Diamond Products, Generac Magnum, Airman, Haulotte, Barreto, Power Blanket, Nifty Lift, Atlas Copco, Chicago Pneumatic, Allmand, Miller Curber, Skyjack, Lull, Skytrak, Tsurumi, Husquvarna Target, Stow, Wacker, Sakai, Mi-T-M, Sullair, Basic, Dynapac, MBW, Weber, Bartell, Bennar Newman, Haulotte, Ditch Runner, Menegotti, Morrison, Contec, Buddy, Crown, Edco, Wyco, Bomag, Laymor, EZ Trench, Bil-Jax, F.S. Curtis, Gehl Pavers, Heli, Honda, ICS/PowerGrit, IHI, Partner, Imer, Clipper, MMD, Koshin, Rice, CH&E, General Equipment, Amida, Coleman, NAC, Gradall, Square Shooter, Kent, Stanley, Tamco, Toku, Hatz, Kohler, Robin, Wisconsin, Northrock, Oztec, Toker TK, Rol-Air, APT, Wylie, Ingersoll Rand / Doosan, Innovatech, Con X, Ammann, Mecalac, Makinex, Smith Surface Prep, Small Line, Wanco, Yanmar