

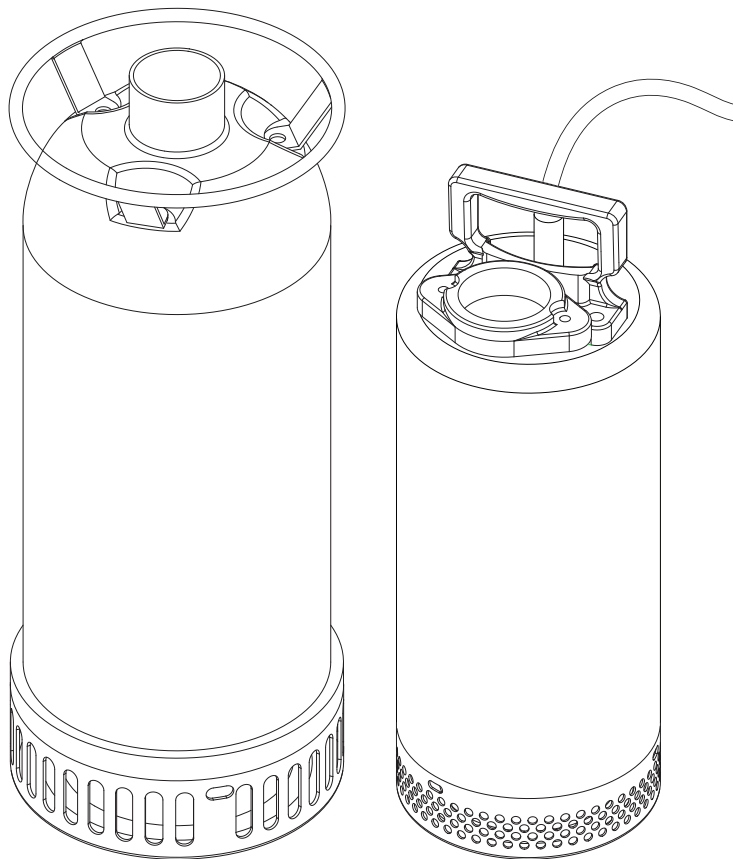

SUBMERSIBLE CONTRACTOR PUMP
MSC 2101 • MSC 2202 • MSC 2302
MSC 3202 • MSC 3302



OPERATING/PARTS MANUAL

INTRODUCTION

This manual provides information and procedures to safely operate and maintain the pump. For your own safety and protection from physical injury, carefully read, understand, and observe the safety instructions described in this manual. Keep a copy of this manual with the unit at all times. Additional copies are available from Magnum Products LLC, or can be found at www.m-p-llc.com. *The information contained in this manual was based on machines in production at the time of publication. Magnum Products LLC reserves the right to change any portion of this information without notice.*

DO NOT MODIFY or use this equipment for any application other than which it was designed for.

MAGNUM PRODUCTS LLC
215 Power Drive • Berlin, WI 54923
U.S.A.
Phone: 920-361-4442
FAX: 920-361-4416
Toll Free: 1-800-926-9768
www.m-p-llc.com

For technical or parts QUESTIONS, please contact Magnum Products' Customer Support or Technical Support team at 920-361-4442 or toll free at 1-800-926-9768. Please have your serial number available.

To ORDER SERVICE PARTS, please contact the dealer from which you purchased the unit, or call Magnum Products to locate a dealer in your area.

Unit Model Number: _____
Unit Serial Number: _____

TABLE OF CONTENTS

	Page
INTRODUCTION	2
TABLE OF CONTENTS	3
SAFETY NOTES	4
OPERATING SAFETY	4
UNIT SERIAL NUMBER LOCATION	5
SPECIFICATIONS	5 - 6
OPERATING THE PUMP	7
CLEANING THE PUMP	7
STORING THE PUMP	7
COMPONENT LOCATIONS - MSC 2101, MSC 2202 & MSC 3202	8
COMPONENT LOCATIONS - MSC 2302 & MSC 3302	9
UNIT ASSEMBLY AND PARTS - MSC 2101, MSC 2202 & MSC 3202	10 - 11
UNIT ASSEMBLY AND PARTS - MSC 2302 & MSC 3302	12 - 13
WIRING DIAGRAM - MSC 2101	14
WIRING DIAGRAM - MSC 2202, MSC 2302, MSC 3202 & MSC 3302	15

SAFETY NOTES



This is the safety alert symbol. It is used to alert you to potential personal injury hazards. Obey all safety messages that follow this symbol to avoid possible injury or death.

This manual contains DANGERS, WARNINGS, CAUTIONS, NOTICES and NOTES which must be followed to prevent the possibility of improper service, damage to the equipment, personal injury or death. The following formatting options will apply when calling the readers attention to the DANGERS, WARNINGS, CAUTIONS, NOTICES and NOTES.

⚠ DANGER

INDICATES A HAZARDOUS SITUATION WHICH, IF NOT AVOIDED, WILL RESULT IN DEATH OR SERIOUS INJURY.

⚠ WARNING

Indicates a hazardous situation which, if not avoided, could result in death or serious injury.

⚠ CAUTION

Indicates a hazardous situation which, if not avoided, may result in minor or moderate injury.

NOTICE

Indicates a hazardous situation which, if not avoided, may result in property or equipment damage.

***Note:** Notes contain additional information important to a procedure and will be found within the regular text body of this manual.*

OPERATING SAFETY



Before using the pump be sure to read and understand all of the instructions! This equipment was designed for specific applications; DO NOT modify or use this equipment for any application other than which it was designed for. Equipment operated improperly or by untrained personnel can be dangerous! Read the operating instructions and familiarize yourself with the location and proper use of all instruments and controls. Inexperienced operators should receive instruction from someone familiar with the equipment before being allowed to operate the pump. The following points should be practiced at all times:

- **NEVER** start a unit in need of repair.
- **NEVER** operate the pump if any of the following conditions exist during operation:
 1. Sparking occurs.
 2. Combustible surface is present.
 3. Protective covers are loose or missing.

⚠ WARNING

Never pump volatile or corrosive chemicals or solutions with this pump. These fluids could create serious health and environmental hazards. High pressure increases the chance of pump explosion which may result in serious personal injury.

UNIT SERIAL NUMBER LOCATION

Refer to the location illustrated below to find the unit ID tag. Important information, such as the unit serial number and model number are found on this tag. Record the information from this tag, so it is available if the tag is lost or damaged. When ordering parts or requesting technical service information, you may be asked to specify this information.

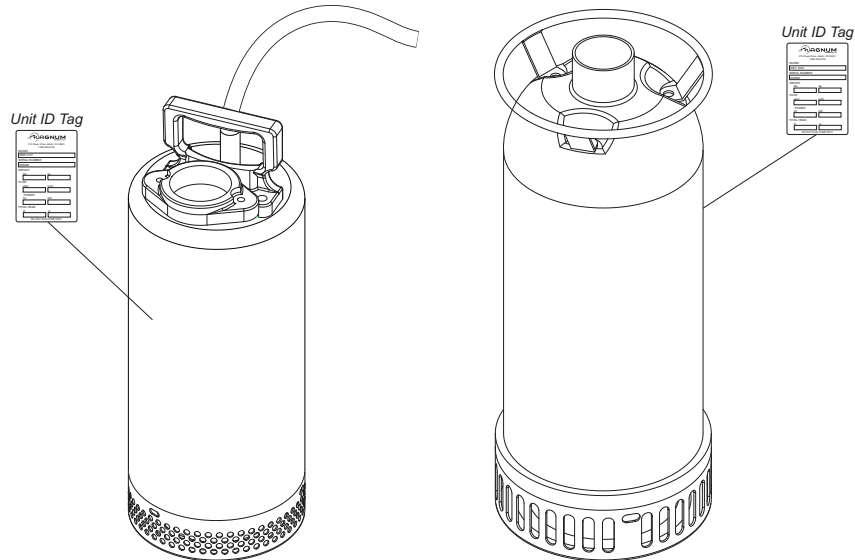

SPECIFICATIONS

Read this manual carefully before attempting to use this pump. The potential for property damage, personal injury or death exists if this equipment is misused or installed incorrectly.

MAGNUM MODEL	MSC 2101	MSC 2202	MSC 2302
Motor Type	1 Ø, 60 hz	1 Ø, 60 hz	1 Ø, 60 hz
Amperage Range (Min. - Max.)*	9.7 - 12.6A	7.7 - 11.8A	10.4 - 16.2A
Voltage	120V	240V	240V

Pump Output

Discharge Diameter	2 in. (50 mm)	2 in. (50 mm)	2 in. (50 mm)
Maximum Head	59.1 ft. (18 m)	72 ft. (22 m)	89 ft. (27 m)
Maximum Discharge	79.3 gpm (300.09 Lpm)	119 gpm (450.33 Lpm)	132 gpm (499.53 Lpm)
Power	1 hp (746 W)	2 hp (1491 W)	3 hp (2237 W)
Solids Handling Capacity2 in. (6 mm)	4x1.4 in. (10x35 mm)	4x1.4 in. (10x35 mm)

Weights and Dimensions

Dry Weight	46 lbs. (21 kg)	81 lbs. (37 kg)	110 lbs. (50 kg)
Shipping Weight	52 lbs. (24 kg)	83 lbs. (38 kg)	112 lbs. (51 kg)
Maximum Diameter	7 in. (180 mm)	9 in. (228 mm)	9 in. (228 mm)
Maximum Height	18 in. (457 mm)	26 in. (650 mm)	26 in. (670 mm)
Cable Length	20 ft. (6 m)	33 ft. (10 m)	33 ft. (10 m)

Other Specifications

Cable Diameter	14AWG	12AWG	12AWG
Impeller Material	HCr	HCr	HCr
Impeller Type	Semi-open	Semi-open	Semi-open
Strainer Material	HCr	HCr	HCr
Seal	Silicone Carbide Mech.	Silicone Carbide Mech.	Silicone Carbide Mech.
Electric Plug Included	Yes	No	No

*Amperage varies upon head and flow.

SPECIFICATIONS ARE SUBJECT TO CHANGE WITHOUT NOTICE.

SPECIFICATIONS

Read this manual carefully before attempting to use this pump. The potential for property damage, personal injury or death exists if this equipment is misused or installed incorrectly.

MAGNUM MODEL	MSC 3202	MSC 3302
Motor Type	1 Ø, 60 hz	1 Ø, 60 hz
Amperage Range (Min. - Max.)*	8.1 - 10.7A	13.4 - 16.6A
Voltage	240V	240V

Pump Output

Discharge Diameter	3 in. (76 mm).....	3 in. (76 mm)
Maximum Head	52 ft. (16 m)	66 ft. (20 m)
Maximum Discharge	172 gpm (650.9 Lpm)	211 gpm (798.49 Lpm)
Power	2 hp (1491 W)	3 hp (2237 W)
Solids Handling Capacity4x1.4 in. (10x35 mm).....	.4x1.4 in. (10x35 mm)

Weights and Dimensions

Dry Weight	91 lbs. (41 kg)	111 lbs. (50 kg)
Shipping Weight	94 lbs. (42 lbs.)	114 lbs. (52 kg)
Maximum Diameter	9 in. (228 mm).....	9 in. (228 mm)
Maximum Height	26 in. (650 mm).....	26 in. (670 mm)
Cable Length.....	33 ft. (10 m)	33 ft. (10 m)

Other Specifications

Cable Diameter	12AWG	12AWG
Impeller Material	HCr	HCr
Impeller Type	Semi-open	Semi-open
Strainer Material.....	HCr	HCr
Seal	Silicone Carbide Mech.	Silicone Carbide Mech.
Electric Plug Included	No	No

*Amperage varies upon head and flow.

SPECIFICATIONS ARE SUBJECT TO CHANGE WITHOUT NOTICE.

OPERATING THE PUMP

1. Connect the discharge hose with the proper fittings.
2. Place the pump in the water. Lower by attaching a strong rope to the handle. The pump should be placed on a flat, hard surface in at least 2 inches of water.

⚠ WARNING

Never lower or move the pump with the electrical cord. Damage to the cord or cord seal could result in equipment damage and/or electrocution.

NOTICE

Do not install the pump on clay, dirt, or sand surfaces. Small stones, gravel, sand, and mud can clog the pump and reduce the performance or cause malfunction of the pump. If necessary, place the pump on a concrete block or slab to prevent the pump from sinking.

3. Connect the grounding-type plug to an outlet.
4. The pump should begin to cycle. To ensure proper operation, observe the pump to make sure it has enough water to avoid cavitation.

⚠ WARNING

Never operate a pump or pump motor with wet hands. Never stand on a wet or damp surface when operating the pump. Doing so could result in equipment damage or personal injury.

⚠ WARNING

To prevent overheating, always keep the pump completely submerged when running continuously. Running the pump continuously while not submerged could result in equipment damage.

CLEANING THE PUMP

After running the pump, wash the pump in clean water. Keep inlet screens clean at all times, and always check the screens before each use.

STORING THE PUMP

Please take the following actions in preparing the unit for storage.

1. Remove pump impeller cover and clean inside of pump housing. Coat inside of pump with a light film of oil to reduce corrosion.
2. Tape up ports to prevent anything from falling into pump.
3. Store in a clean, dry area.

COMPONENT LOCATIONS - MSC 2101, MSC 2202 & MSC 3202

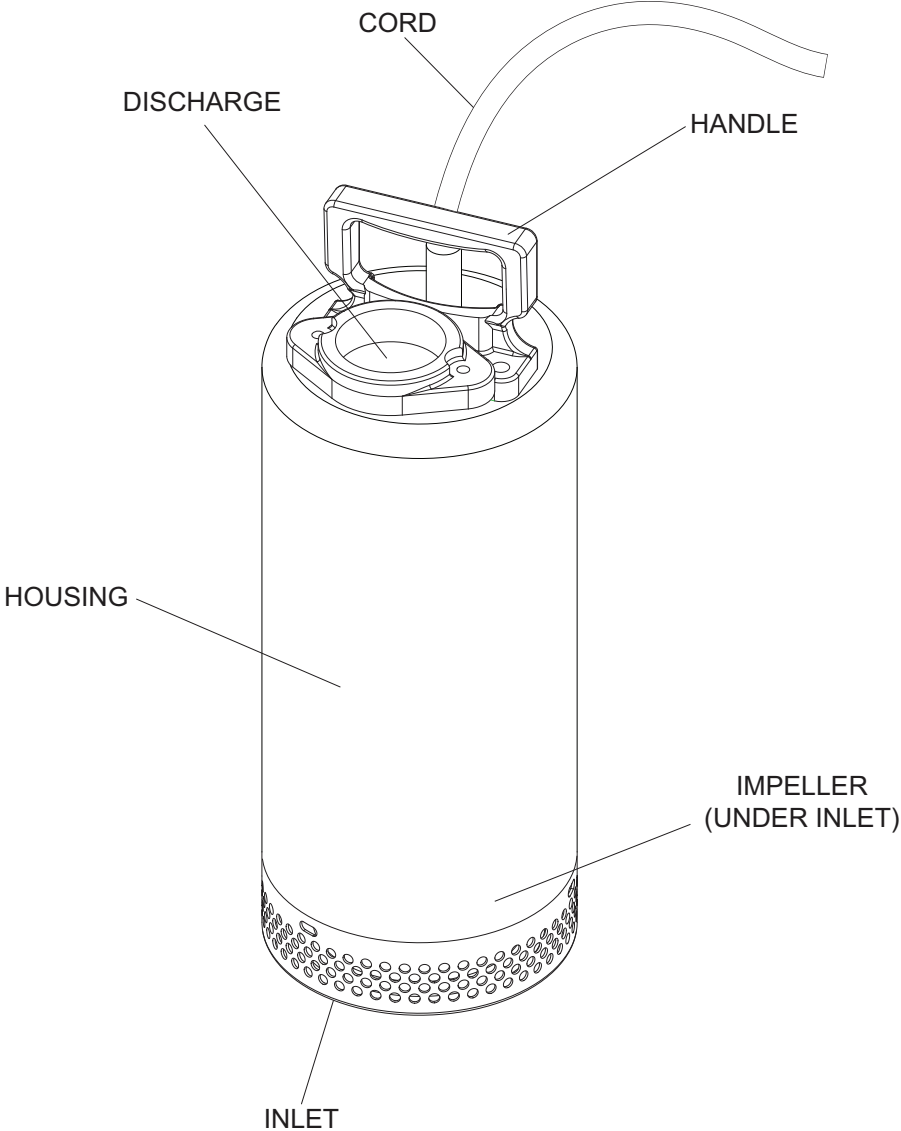

COMPONENT LOCATIONS - MSC 2302 & MSC 3302

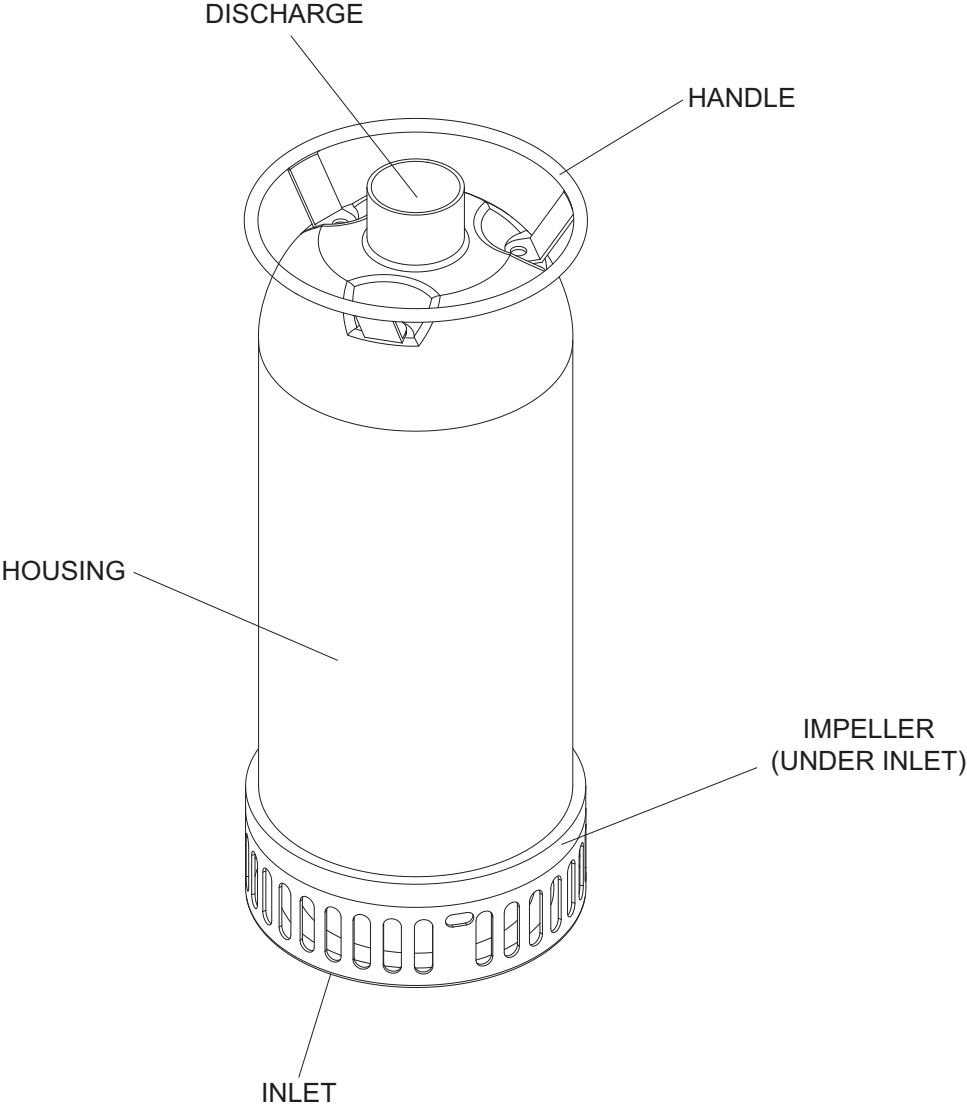

UNIT ASSEMBLY AND PARTS - MSC 2101, MSC 2202 & MSC 3202

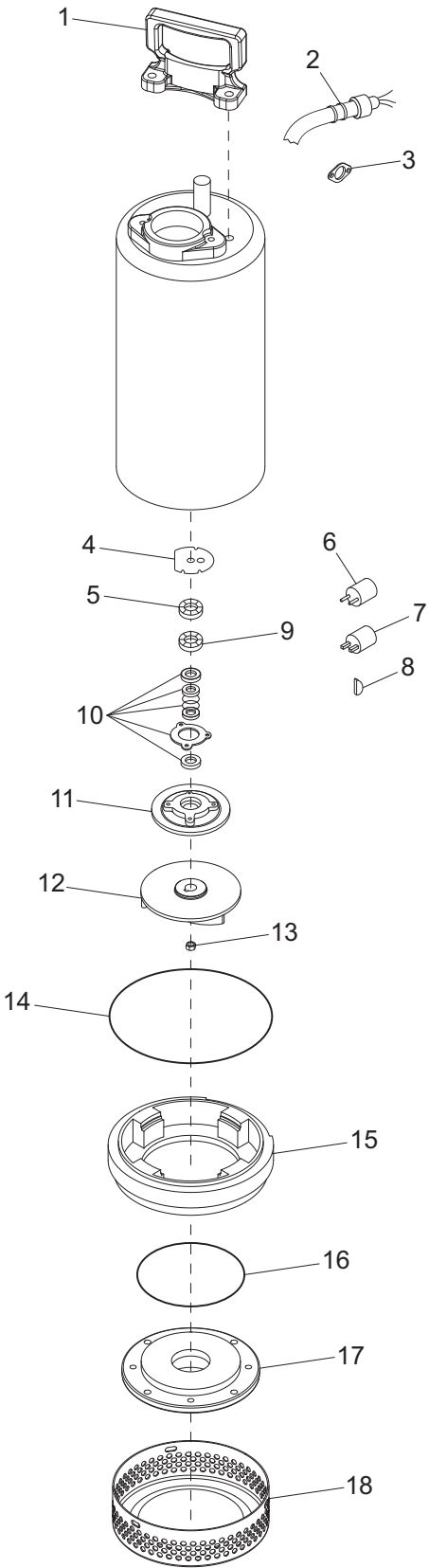

ITEM NO.	PART NO.	QTY	DESCRIPTION	NOTES
1	41618	1	Handle	
2	41612	1	Power cord	For MSC 2202 & 3202
2	41611	1	Power cord	For MSC 2101
3	41770	1	Rubber gasket	For MSC 2202 & 3202
3	41769	1	Rubber gasket	For MSC 2101
4	41720	1	Base-capacitor	
5	41636	1	Upper bearing	For MSC 2202 & 3202
5	41635	1	Upper bearing	For MSC 2101
6	41626	1	Capacitor - run	For MSC 2202 & 3202
6	41625	1	Capacitor - run	For MSC 2101
7	41667	1	Capacitor - start	For MSC 2202 & 3202
7	41616	1	Capacitor - start	For MSC 2101
8	41732	1	Impeller key	For MSC 2202 & 3202
8	41731	1	Impeller key	For MSC 2101
9	41642	1	Lower bearing	
10	41651	1	Mechanical seal	For MSC 2202 & 3202
10	41650	1	Mechanical seal	For MSC 2101
11	41661	1	Seal plate	For MSC 2202 & 3202
11	41660	1	Seal plate	For MSC 2101
12	41691	1	Impeller	For MSC 2101
12	41692	1	Impeller	For MSC 2202
12	41693	1	Impeller	For MSC 3202
13	41783	1	Nut - M12-1.25	For MSC 2202 & 3202
13	41782	1	Nut - M10-1.25	For MSC 2101
14	41764	1	Square ring	For MSC 2202 & 3202
14	41763	1	Square ring	For MSC 2101
15	41686	1	Pump casing	For MSC 2202 & 3202
15	41685	1	Pump casing	For MSC 2101
16	41758	1	O-ring - 4"	
17	41701	1	Suction cover	For MSC 2101
17	41706	1	Suction cover	For MSC 2202
17	41703	1	Suction cover	For MSC 3202
18	41711	1	Strainer	For MSC 2202 & 3202
18	41710	1	Strainer	For MSC 2101
-	41630	1	Centrifugal switch	Not shown
-	41745	1	O-ring - .375"	Not Shown

UNIT ASSEMBLY AND PARTS - MSC 2302 & MSC 3302

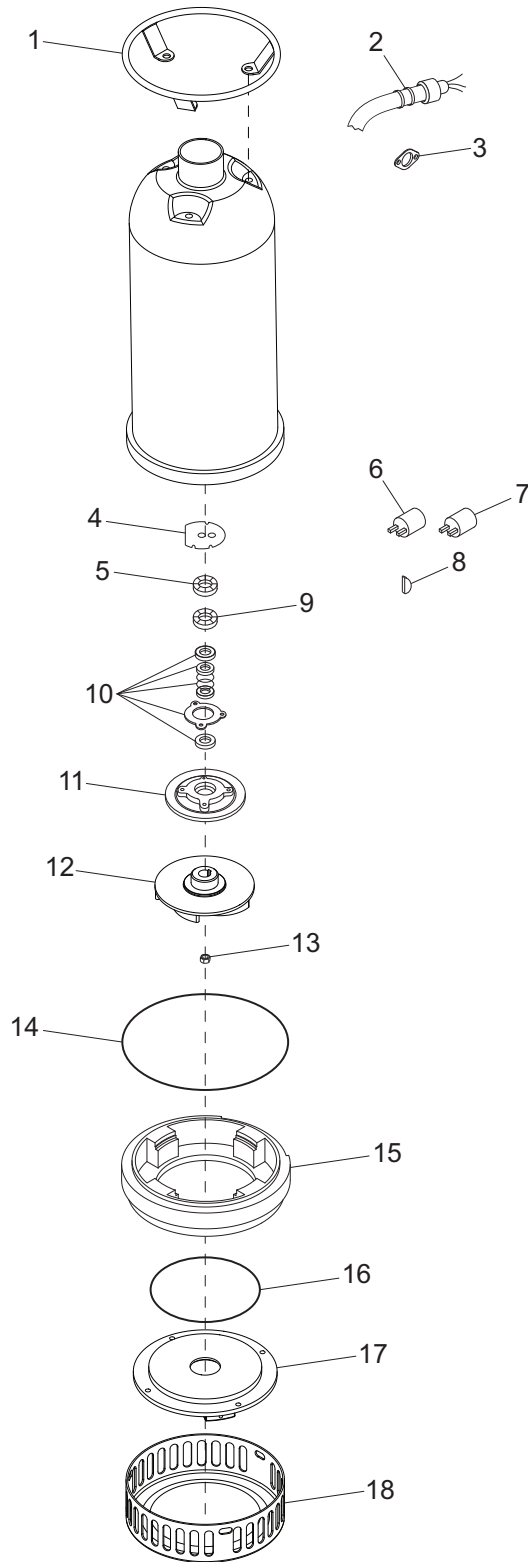

ITEM NO.	PART NO.	QTY	DESCRIPTION	NOTES
1	41620	1	Handle	
2	41613	1	Power cord	
3	41770	1	Rubber gasket	
4	41720	1	Base-capacitor	
5	41637	1	Upper bearing	
6	41626	1	Capacitor - run	
7	41667	1	Capacitor - start	
8	41732	1	Impeller key	
9	41644	1	Lower bearing	
10	41652	1	Mechanical seal	
11	41661	1	Seal plate	
12	41694	1	Impeller	For MSC 3302
12	41695	1	Impeller	For MSC 2302
13	41783	1	Nut - M!@-1.25	
14	41764	1	Square ring	
15	41686	1	Pump casing	
16	41758	1	O-ring - 4"	
17	41704	1	Suction cover	For MSC 3302
17	41706	1	Suction cover	For MSC 2302
18	41712	1	Strainer	
-	41630	1	Centrifugal switch	Not shown
-	41745	1	O-ring - .375"	Not shown

WIRING DIAGRAM - MSC 2101

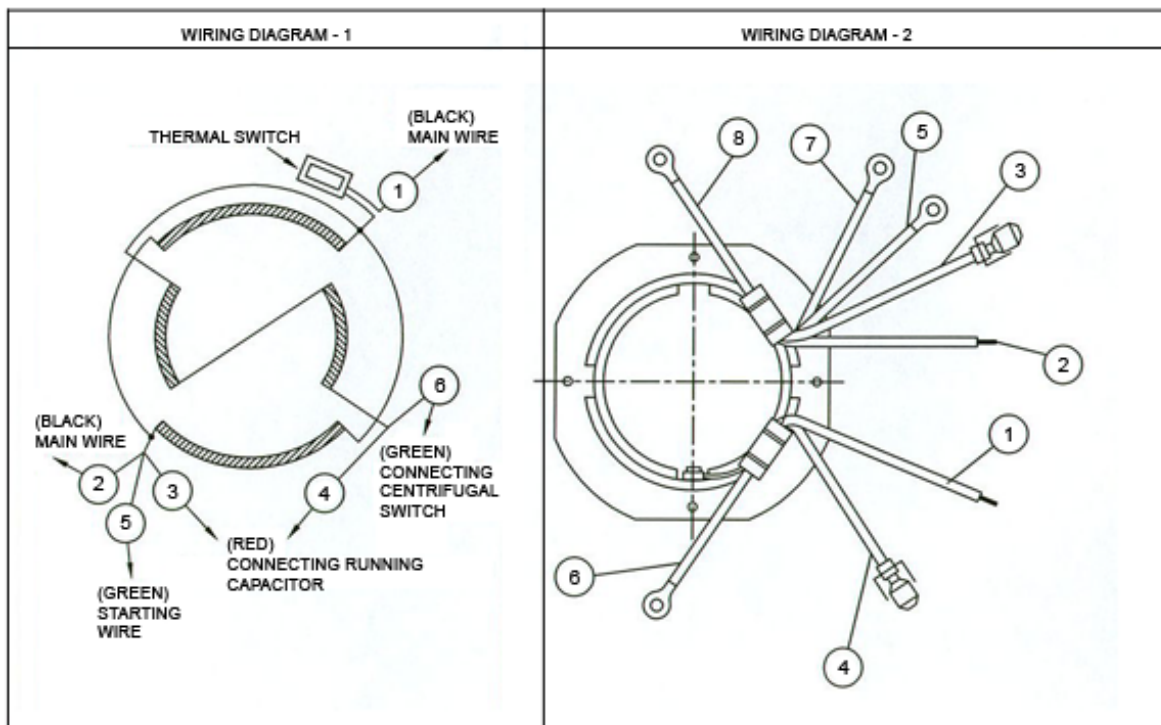

WIRING DIAGRAM - MSC 2202, MSC 2302, MSC 3202 & MSC 3302

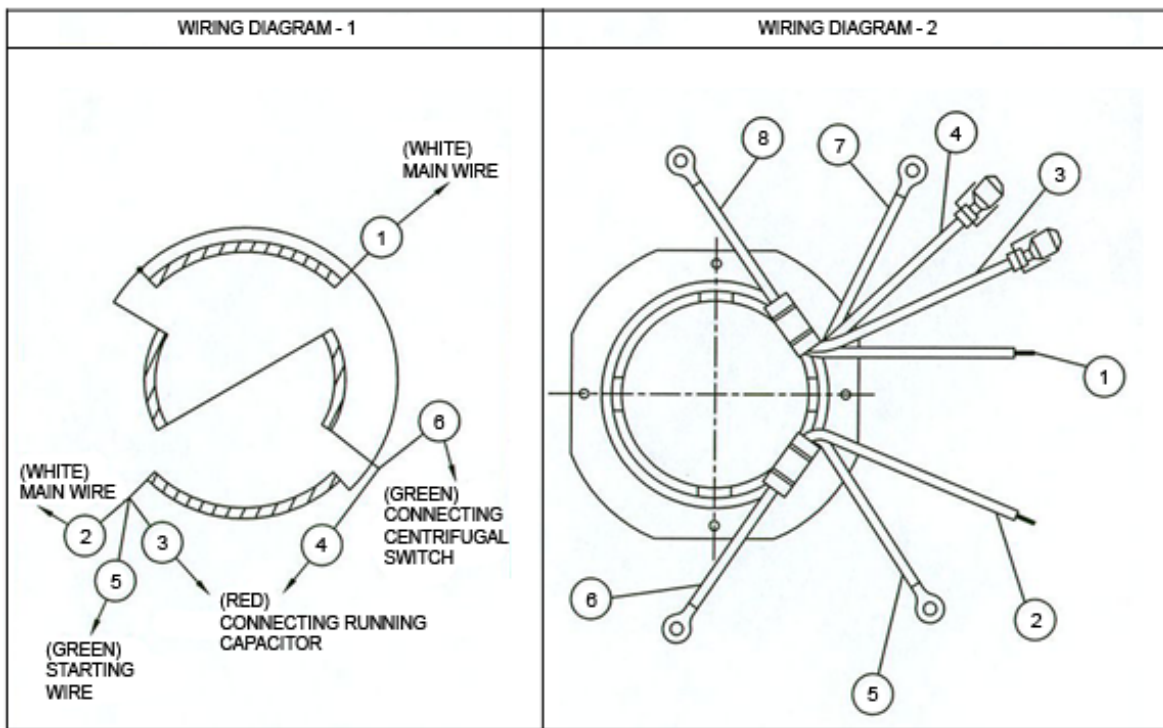

REV: A
PART NO: 41866
01.28.09