

# CLEMCO®

## Classic *Blast Machines*



**The Performance System**

# Classic Clemco – Tough, Reliable, Quality Blast Machines

Semi-elliptical head for larger storage of abrasive.

Urethane-coated pop-up valve with external sleeve for long wear life and fast pressurization.

Large 6" x 8" inspection door for easy access to inside.

Heavy-gauge construction pressure vessel fabricated for rugged field service. Built to ASME standards.

Conical 35° bottom ensures total use of abrasive and uninterrupted abrasive flow.

45° abrasive flow into air stream – the natural way to uniformly mix air and abrasive. Eliminates premature wear found in 90° systems. A tough stainless steel plate meters precisely. Clean-out provides access to foreign matter.

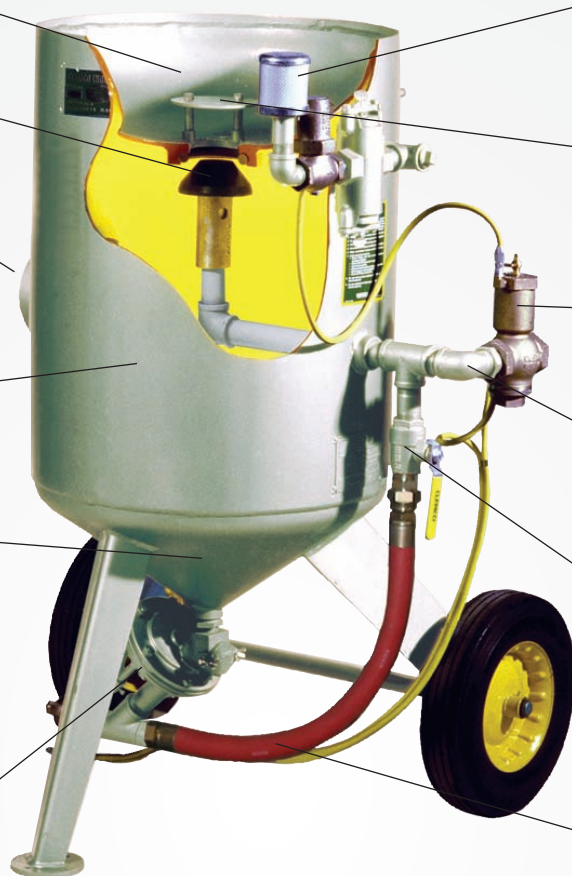

Self-cleaning exhaust muffler greatly reduces bleed-off noise.

Pop-up valve umbrella (optional) relieves load pressure, when hopper is in place.

Fast, safe remote controls built for years of dependability.

Heavy-duty piping assembled tightly against tank avoids unnecessary protrusions.

Full-flow stainless steel teflon-sealed ball valve with brass body provides unrestricted air flow.

Flexible pusher line guarantees air flow without pressure loss caused by elbows; and eases valve replacement.

**Built to offer years of reliable service.**

## U.S. Standard Compressed Air and Abrasive Consumption

Nozzle Orifice	Pressure at the Nozzle (psi)								Air (in cfm) Abrasive & HP requirements
	50	60	70	80	90	100	125	140	
<b>No. 2</b> (1/8")	11	13	15	17	18.5	20	25	28	Air (cfm)
	.67	.77	.88	1.01	1.12	1.23	1.52	1.70	Abrasive (cu.ft./hr & Lbs/hr)
	67	77	88	101	112	123	152	170	Compressor hp
	2.5	3	3.5	4	4.5	5	5.5	6.2	
<b>No. 3</b> (3/16")	26	30	33	38	41	45	55	62	Air (cfm)
	1.50	1.71	1.96	2.16	2.38	2.64	3.19	3.57	Abrasive (cu.ft./hr & Lbs/hr)
	150	171	196	216	238	264	319	357	Compressor hp
	6	7	8	9	10	10	12	13	
<b>No. 4</b> (1/4")	47	54	61	68	74	81	98	110	Air (cfm)
	2.68	3.12	3.54	4.08	4.48	4.94	6.08	6.81	Abrasive (cu.ft./hr & Lbs/hr)
	268	312	354	408	448	494	608	681	Compressor hp
	11	12	14	16	17	18	22	25	
<b>No. 5</b> (5/16")	77	89	101	113	126	137	168	188	Air (cfm)
	4.68	5.34	6.04	6.72	7.40	8.12	9.82	11.0	Abrasive (cu.ft./hr & Lbs/hr)
	468	534	604	672	740	812	982	1100	Compressor hp
	18	20	23	26	28	31	37	41	
<b>No. 6</b> (3/8")	108	126	143	161	173	196	237	265	Air (cfm)
	6.68	7.64	8.64	9.60	10.52	11.52	13.93	15.60	Abrasive (cu.ft./hr & Lbs/hr)
	668	764	864	960	1052	1152	1393	1560	Compressor hp
	24	28	32	36	39	44	52	58	
<b>No. 7</b> (7/16")	147	170	194	217	240	254	314	352	Air (cfm)
	8.96	10.32	11.76	13.12	14.48	15.84	19.31	21.63	Abrasive (cu.ft./hr & Lbs/hr)
	896	1032	1176	1312	1448	1584	1931	2163	Compressor hp
	33	38	44	49	54	57	69	77	
<b>No. 8</b> (1/2")	195	224	252	280	309	338	409	458	Air (cfm)
	11.60	13.36	15.12	16.80	18.56	20.24	24.59	27.54	Abrasive (cu.ft./hr & Lbs/hr)
	1160	1336	1512	1680	1856	2024	2459	2754	Compressor hp
	44	50	56	63	69	75	90	101	

## CLEMCO ABRASIVE METERING VALVES

### Application Guide

Model/Description	Standard Equipment on:	Stock No.	Manual or Pneumatic	Remote Control Type	Applications (abrasives/media)	Alternate Use
FSV Flat Sand Valve	Classic blast machine, 2 cuft and larger	02427	Manual	Pressure Release	Use with expendable mineral & slag abrasives; does not work well with metallic media.	
Quantum Valve	Contractor & Classic machines	22845	Manual	Pressure Release	Use with all common abrasives; mineral, slag, or metallic.	
LPV Valve	Lo-Pot machines	05680	Manual	Pressure Release	Use with expendable mineral & slag abrasives.	
MSV Valve	0.5 & 1 cuft Classic machines	01247	Manual	Pressure Release	Use with expendable mineral & slag abrasives; not recommended for use with fine mesh media or glass bead.	Machines with 1/2" piping
Sentinel Valve	Classic machines with pressure-hold remotes or ACS; industrial blast machines.	20508	Pneumatic	Pressure-hold and abrasive cut-off systems	ACS applications: all media; use with abrasives coarser than 50 mesh; requires 50 to 70 psi to fully open plunger.	2 cuft & larger machines

## Metering Valves — *Precise Abrasive Metering*

One of the most important features of the blast machine is the abrasive metering valve. Selecting the right valve for your application is the key to productivity and efficiency.

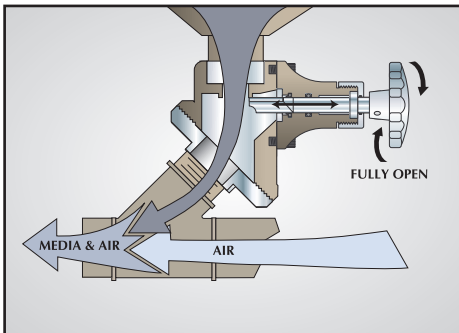

The Quantum valve handles all types of media, minerals, slags, and metallic media. Its simple design with few moving parts allows for precise media metering and easy maintenance. The Quantum fits machines from 2 to 20 cubic feet.

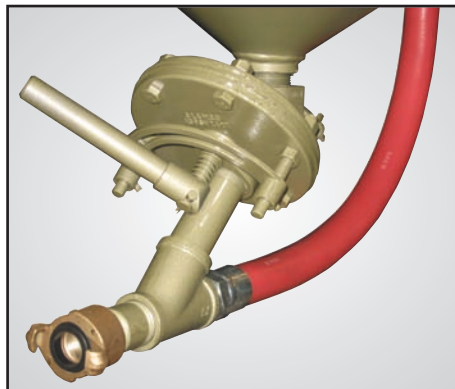

The FSV is the tried-and-true, work horse of the industry, an original Clemco design, now copied across the globe. It is used on machines from 2-cubic feet to 20-cubic feet.

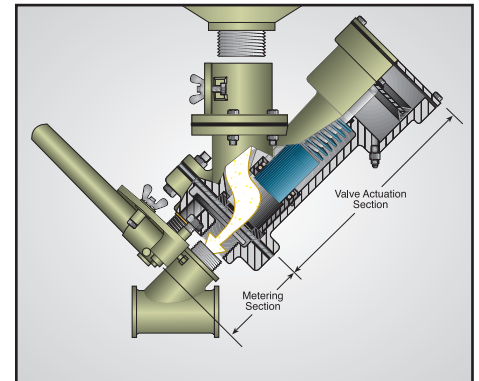

The normally-closed Sentinel valve is used on 2- to 20-cubic foot machines. It handles all media types, and has an abrasive cut-off (ACS) feature. The ACS allows the operator to shut off the abrasive flow and blow off the surface with air after blasting. The Sentinel is used on pneumatic and electric pressure-release systems and on pneumatic and electric pressure-hold systems.

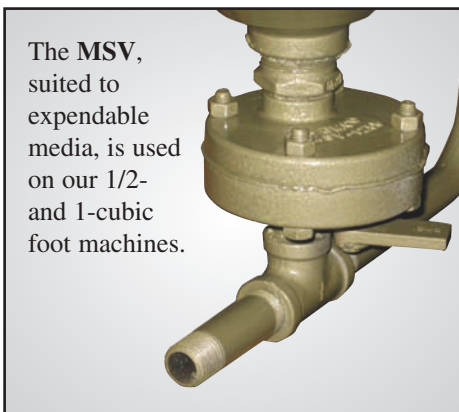

The MSV, suited to expendable media, is used on our 1/2- and 1-cubic foot machines.

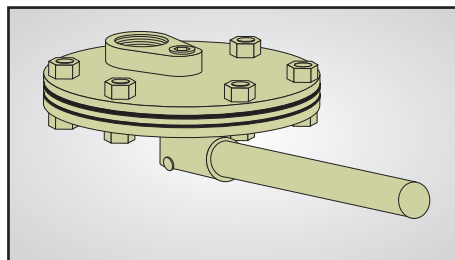

The LPV is a low-profile valve for mineral and slag abrasives used on Lo-Pots.

The FSV, Quantum, and Sentinel valves are designed to feed abrasive into the air stream at 45 degrees. This design feature eliminates turbulence, minimizes wear on fittings, and ensures smooth, consistent flow.

# CLEMCO

# Classic

## Blast Machine Systems

### *Rugged, Reliable, Proven*

More than fifty years of reliable field service have made Clemco blast machines the preferred equipment for industrial blasting and painting contractors.

Clemco machines are built tough to endure real world use. With wear-parts positioned for quick replacement, Clemco blast machines virtually eliminate downtime, so they spend more time at the job site; less time in the shop.

Choose from 1/2-cu. ft. to 20-cu. ft. capacity, in portable or stationary models — blast machine only or machine system.

Take the guesswork out of buying a blast machine by ordering a complete system, which includes the blast machine, remote controls, nozzle, couplings, blast hose, Apollo helmet, air filter, and spare parts — everything but the compressed-air components and abrasive.

### BLAST MACHINE CONSTRUCTION

- Pressure vessels built to ASME code.
- Concave head stores abrasive for loading.
- Conical bottom ensures smooth abrasive flow and complete emptying.
- Large inspection door for access to the interior.
- Wear-resistant urethane-coated pop-up valve seals tight and lasts longer.

### BLAST MACHINES FOR INDUSTRIAL APPLICATIONS

Stationary models are suitable for industrial use in blast rooms or for other applications requiring a large volume, yet economical, blast machine. Stationary machines adapt to fixed sites or to custom truck (or trailer) mounted systems.



Clemco's smaller machines are light, transportable, and industrial quality.

#### Model 1028

1/2 cubic foot capacity

#### Model 1042

1 cubic foot capacity

Tall and slim, can be moved empty with ease from blast site to blast site.



#### Complete System

Clemco's fully equipped and accessorized systems offer everything needed to blast except air and abrasive.



#### Model 3661

10 cubic foot capacity

#### Model 3680

20 cubic foot capacity

# Blast Machines and Remote Controls



*150 psi Working Pressure is standard on this model.*

Decades of experience enable Clemco to produce blast machines suitable for a wide range of jobs.

**Model 1642**  
2 cubic foot capacity

**Model 1648**  
3 cubic foot capacity  
A mid-size blast machine, a favorite of rental yards.

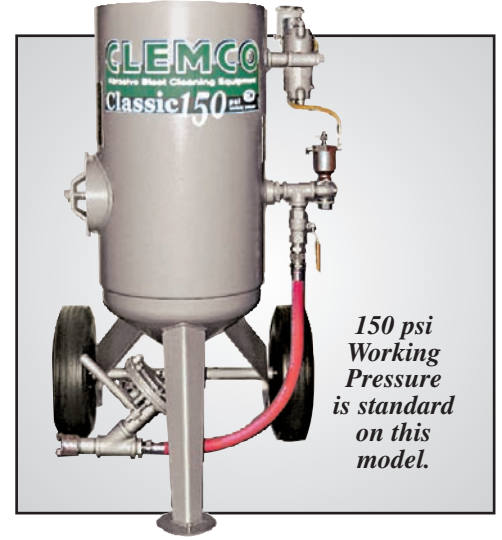

*150 psi Working Pressure is standard on this model.*



**Model 1642**

**Model 2452**  
6 cubic foot capacity

This larger capacity blast machine is the obvious choice for professional blasting contractors, shipyards, railcar re-man facilities and large scale industrial production.

**Model 1642**  
2 cubic foot capacity



*150 psi Working Pressure is standard on this model.*



**Model 2463**  
8 cubic foot capacity

Dual blast chambers permit continuous blasting. Twin outlets allow two operators to work without interference.

**Model 2443**  
6 cubic foot capacity  
Lo-Pot Blast Machines are designed for ease in abrasive loading.

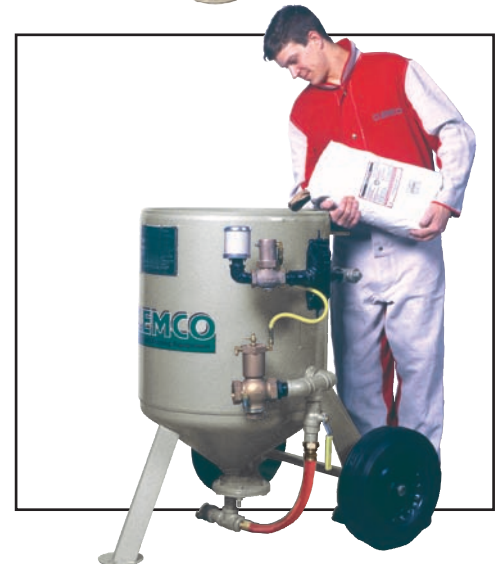

# Remote Controls — *Critical Operator Safety Accessory*

OSHA's requirements for remote control blasting safety lie at the heart of Clemco's Remote Control Systems:

*“Abrasive blast cleaning nozzles shall be equipped with an operating valve which must be held open manually... (OSHA 1926.302 (b) (10)*

*A ‘deadman’ control device shall be provided at the nozzle end of the blasting hose ...to provide direct cutoff (of abrasive to the blast hose) in the event the blaster loses control of the hose... (OSHA 1915.34 (c) (1) (iv)”*

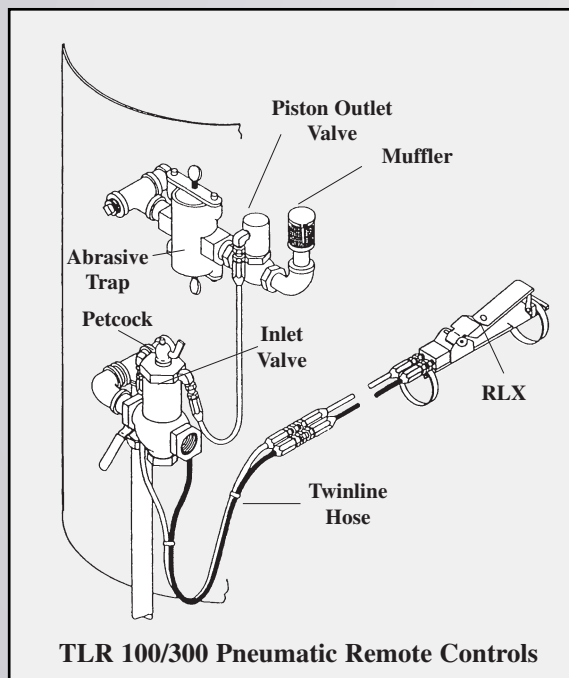

The Clemco **TLR 100 and 300 pressure-release pneumatic systems** operate on the return-air principle. A handle installed at the nozzle connects pneumatically to inlet and outlet valves on the blast machine. With the safety petcock on the inlet valve closed, the operator depresses the handle which opens the inlet valve and closes the outlet to start blasting; releasing the handle reverses the process and blasting stops. This safety system stops blasting should the operator lose control of the nozzle. And when the blast session is over, the safety petcock is opened to prevent activation, even when the handle is depressed.

TLR 50 for 1/2-inch piped machines operates similarly but is not shown.

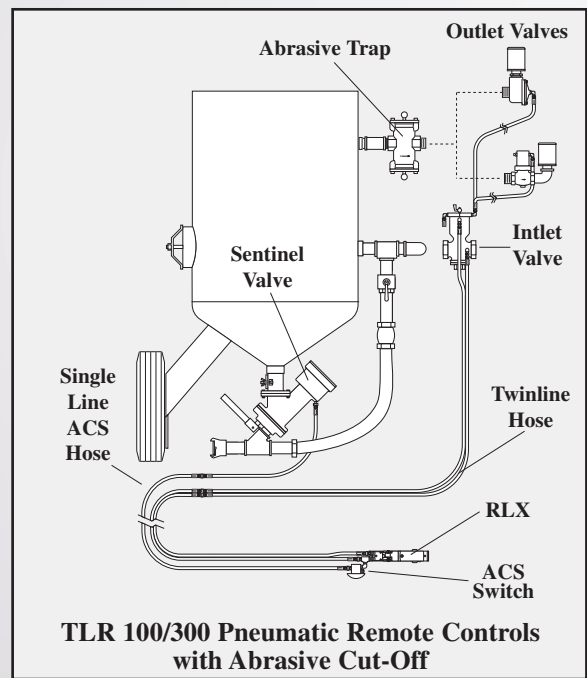

The Clemco **TLR 100C and 300C pressure-release pneumatic systems** feature an abrasive cut-off system (ACS), which permits the operator to shut-off the abrasive flow for blowing down the surface after blasting. These remote control systems include inlet and outlet valves, abrasive trap, self-cleaning muffler that reduces air exhaust noise, and the air-operated normally-closed Sentinel abrasive metering valve.

Apart from respiratory protection, the most important blasting safety accessory is the remote control. All Clemco remote control systems meet the OSHA requirements for remote controlled blasting.



Clemco's RLX remote control handle;  
*...the industry standard for twenty-five years!*

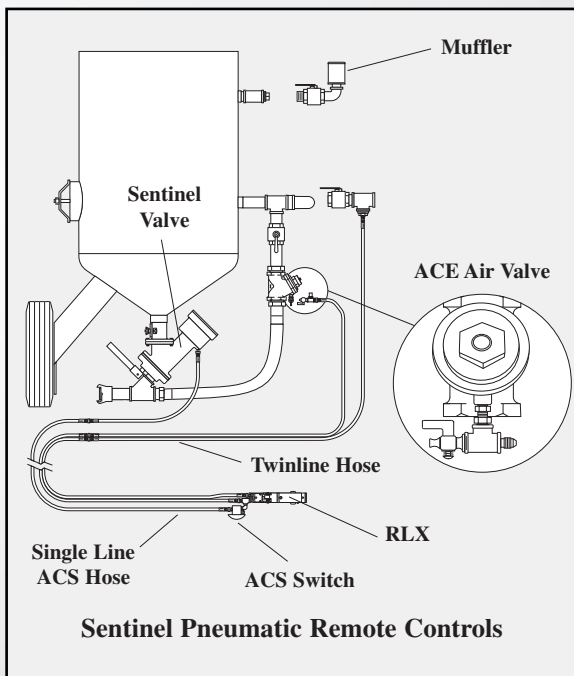

For applications that require frequent starts and stops, machines should be equipped with **Sentinel pressure-hold pneumatic remote controls**, which keep the blast machine under pressure but allow the operator to start and stop blasting as frequently as needed. The machine is pressurized and depressurized manually, and the remote control handle controls the on/off of the abrasive and air independently. These systems are available in pneumatic and electric models.

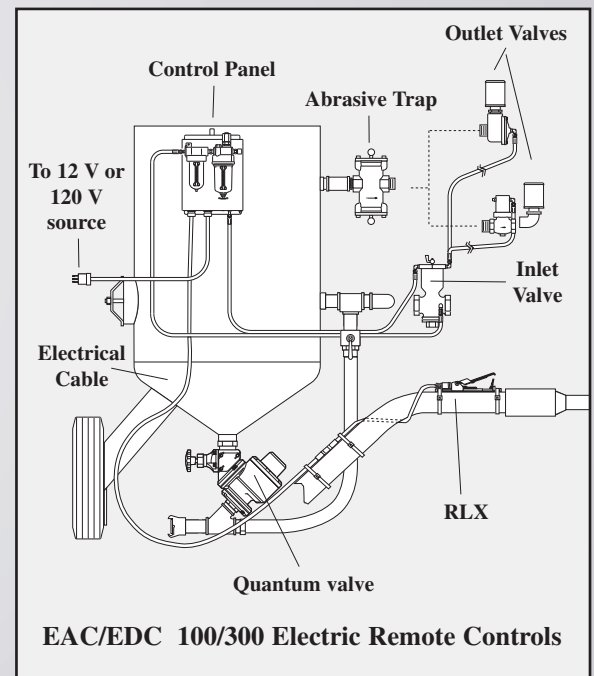

The Clemco **EAC 100/300 (AC electrics) and EDC 100/300 (DC electrics) pressure-release electric remote control systems** are available for extremely cold weather applications or where a continuous length of 100 feet or more of blast hose is used. An electric switch sends a signal through electric cord to open and close the inlet and outlet valves, avoiding the delay that would be experienced with air hose. Electric systems feature an anti-freeze injector accessory, which is optional on pneumatic systems. Electric remotes operate on a compressor's 12-volt system or 120-volt line power. Only 12-volt power reaches the handle for the safety of the operator.

# SPECIFICATIONS

Model	Dimensions Dia x Height	Standard Working Pressure	Capacity Cu Ft.	Portable or Stationary	Piping (I.D.)	ACS Option	Remote Controls Pneu. or Elec.	Metering Valve	Pop-up Valve & O-ring
1028	10" x 28"	125 psi	1/2 cu. ft.	Portable	1/2"	Not Available	TLR 50 pneu. only	MSV	01242 01245
1042	10" x 42"	125 psi	1 cu. ft.	Portable	1/2"	Not Available	TLR 50 pneu. only	MSV	01242 01245
1642	16" x 42"	150 psi	2 cu. ft.	Portable & Stationary	1"	Available	TLR 100 or Sentinel pneu. or elec.	FSV	03699 02325
1648	16" x 48"	150 psi	3 cu. ft.	Portable & Stationary	1" or 1-1/4"	Available	TLR 100, 300, or Sentinel pneu. or elec.	FSV, Quantum or Sentinel	03699 02325
2443	24" x 43"	125 psi	6 cu. ft.	Portable	1" or 1-1/4"	Not Available	TLR 100 or 300 pneu. or elec.	LPV	03699 02325
2452	24" x 52"	150 psi	6 cu. ft.	Portable & Stationary	1" or 1-1/4"	Available	TLR 100, 300, or Sentinel pneu. or elec.	FSV, Quantum or Sentinel	03699 02325
2463	24" x 63"	125 psi	8 cu. ft.	Portable & Stationary	1-1/4"	Available	Sentinel pressure hold only	Sentinel only	03699 02325
3054	30" x 54"	125 psi	7 cu. ft.	Stationary	1-1/4"	Available	TLR 300 or Sentinel pneu. or elec.	FSV or Sentinel	03699 02325
3079	30" x 79"	125 psi	14 cu. ft. (pot & hopper)	Stationary	1-1/4"	Available	TLR 300 or Sentinel pneu. or elec.	FSV or Sentinel	03699 02325
3661	36" x 61"	125 psi	10 cu. ft.	Stationary	1-1/4"	Available	TLR 300 or Sentinel pneu. or elec.	FSV or Sentinel	03699** 02325
3680	36" x 80"	125 psi	20 cu. ft.	Stationary	1-1/4"	Available	TLR 300 or Sentinel pneu. or elec.	FSV or Sentinel	03699 02325

**NOTES:**

\*\* 10 cu. ft. machines manufactured before 1983 use different pop-up valve and seat. Consult your Clemco distributor for details.

MSV, FSV, and LPV abrasive metering valves are suitable for blasting with mineral and slag expendable media. The Quantum and Sentinel metering valves handle all common media including steel grit.

ACS is an optional accessory for remotes with Sentinel metering valves.

**Remote Controls:**

Remote control systems have valves matched in size to the blast machine piping. Remote Control System styles vary to suit the blasting operation or application. Pneumatic Remote Controls work best with blast hose lengths up to 100 ft.; and Electric Remotes, powered electro-pneumatically, are for hose lengths greater than 100 ft.

Machine Piping Size	Pressure-Release		Pressure-Release w/ACS		Pressure-Hold		Pneumatic or Electric
	Pneumatic	Electric	Pneumatic	Electric	Pneumatic	Electric	
1/2"	TLR 50	—	—	—	—	—	pneumatic only
1"	TLR 100	EAC 100 or EDC 100	TLR 100C	EAC 100C or EDC 100C	—	—	pneumatic or electric
1-1/4"	TLR 300	EAC 300 or EDC 300	TLR 300C	EAC 300C or EDC 300C	Sentinel Remote Controls Single and dual operator systems available; consult distributor for details.		pneumatic or electric

**Piping Size:** Size varies with pressure vessel capacity. Choose larger diameter piping for high production operations.

**Pressure-Release Remotes:** Pressurize/depressurize machine by pressing/releasing handle — simplest system to operate.

**Pressure-Release with Abrasive Cut-off:** Allows the operator to stop the flow of abrasive to blow off the surface after blasting.

**Pressure-Hold Remotes:** Keep the blast machine under pressure for frequent starting and stopping.

ISO 9001-2000 certified. Clemco is committed to continuous product improvement.

Specifications are subject to change without notice.

Distributed by: