

WWS 463

Reservdelar

Spare parts

Ersatzteile

Pieces de rechange

Piezas de repuesto

Ricambi

Peças sobresselente



# PARTS FINDER

**Search Website  
by Part Number**



**Search Manual  
Library For Parts  
Manual & Lookup Part  
Numbers – Purchase  
or Request Quote**

**Can't Find Part or  
Manual? Request Help  
by Manufacturer,  
Model & Description**

Discount-Equipment.com is your online resource for quality parts & equipment.

Florida: **561-964-4949** Outside Florida TOLL FREE: **877-690-3101**

**Need parts?**

Click on this link: <http://www.discount-equipment.com/category/5443-parts/> and choose one of the options to help get the right parts and equipment you are looking for. Please have the machine model and serial number available in order to help us get you the correct parts. If you don't find the part on the website or on one of the online manuals, please fill out the request form and one of our experienced staff members will get back to you with a quote for the right part that your machine needs.

We sell worldwide for the brands: Genie, Terex, JLG, MultiQuip, Mikasa, Essick, Whiteman, Mayco, Toro Stone, Diamond Products, Generac Magnum, Airman, Haulotte, Barreto, Power Blanket, Nifty Lift, Atlas Copco, Chicago Pneumatic, Allmand, Miller Curber, Skyjack, Lull, Skytrak, Tsurumi, Husquvarna Target, Stow, Wacker, Sakai, Mi-T-M, Sullair, Basic, Dynapac, MBW, Weber, Bartell, Bennar Newman, Haulotte, Ditch Runner, Menegotti, Morrison, Contec, Buddy, Crown, Edco, Wyco, Bomag, Laymor, EZ Trench, Bil-Jax, F.S. Curtis, Gehl Pavers, Heli, Honda, ICS/PowerGrit, IHI, Partner, Imer, Clipper, MMD, Koshin, Rice, CH&E, General Equipment, Amida, Coleman, NAC, Gradall, Square Shooter, Kent, Stanley, Tamco, Toku, Hatz, Kohler, Robin, Wisconsin, Northrock, Oztec, Toker TK, Rol-Air, APT, Wylie, Ingersoll Rand / Doosan, Innovatech, Con X, Ammann, Mecalac, Makinex, Smith Surface Prep, Small Line, Wanco, Yanmar

No.	Pos.	Description	No.	Pos.	Description
501 37 29-01	M	Outer side Right 800mm compl.	531 11 30-46	H	Track 2,0m complete
501 37 30-01	M	Outer side Left 800mm compl.	531 11 30-47	H	Track 2,2m complete
501 37 31-01	M	Outer side Right 1000mm compl.	531 11 30-78	F	Shaft seal set
501 37 32-01	M	Outer side Left 1000mm compl.	531 11 31-69	B	Worm gear + comm. valve 50:1
501 37 33-01	M	Outer side Right 1240mm compl.	531 11 32-00	J	Mounting bracket universal
501 37 34-01	M	Outer side Left 1240mm compl.	531 11 32-44	D	Pivoting arm compl.
501 37 52-01	P	Tool kit	531 11 32-46	H	Mounting bracket complete
504 00 50-01	M	Flush bladeguard 800mm compl.	531 11 32-47	H	Coupling link complete
504 00 52-01	M	Flush bladeguard 1000mm cpl.	531 11 32-48	H	Track holder complete
504 00 53-01	M	Flush bladeguard 1240mm cpl.	531 11 32-51	B	Motor bracket complete
504 10 02-01	J	Scale	531 11 32-52	B	Feeding motor, track feed
504 10 29-01	P	Toolbag	531 11 32-54	B	Feeding motor, down feed
505 11 29-01	K	Mount	531 11 32-55	F	Hydraulic motor compl. WS 463
505 11 30-01	K	Excentric	531 11 32-58	G	Guide wheel concentric compl.
505 11 31-01	K	Handle bracket	531 11 32-59	G	Guide wheel excentric compl.
505 11 33-01	K	Beam	531 11 32-65	J	Measure rod complete
505 11 34-01	K	Snap locking	531 11 32-68	Q	Cleaning brush complete
505 11 35-01	K	Hook	531 11 32-71	C	Clutch trackfeeding compl.
505 11 37-01	K	Handle holder	531 11 33-03	G	Saw carriage complete
505 11 38-01	K	Handle	531 11 33-43	Q	Hose complete
505 11 39-01	K	Shaft seat	531 11 73-43	L	Potentiometer knob
505 11 40-01	K	Spring	531 11 80-03	Q	Quick coupling 1800UV female
505 11 40-01	K	Spring	531 11 80-05	Q	Nipple 1812
505 11 42-01	A	Spacing sleeve	531 11 80-06	Q	Quick coupling 18210 male
505 11 99-01	L	Tube	531 11 80-18	Q	Ball valve
505 12 00-01	L	Bracket	531 11 80-41	F	Hydraulic coupling 1/2" female
505 12 02-01	L	Cone	531 11 80-42	F	Hydraulic coupling 1/2" male
505 12 03-01	L	Cone	531 11 80-45	B	Hydraulic coupling 1/8" female
505 12 04-01	L	Shaft	531 11 80-46	B	Hydraulic coupling 1/8" male
505 12 05-01	L	Locking plate	531 11 81-13	D	Magnetic plug
505 12 06-01	L	Locking plate	531 11 81-44	F	Pressure relief valve
505 12 07-01	L	Locking stop	531 11 81-92	Q	Water hose
505 12 08-01	L	Locking stop	531 11 81-93	F	Spring PLC 081-230
505 12 09-01	L	Cone	531 11 81-95	B	Tooth wheel set
505 12 10-01	L	Washer	531 11 81-96	B	Tooth wheel set
505 12 31-01	H	Knob	531 11 81-98	B	Driving shaft
505 12 59-01	G	Rocker lever	531 11 82-18	EQ	Quick coupling, male 13411 M
505 12 60-01	G	Spring	531 11 82-19	Q	Quick coupling 1300UV female
505 15 29-01	L	Blade guard D800mm Assy	531 11 83-18	Q	Hose 0,45m
505 15 30-01	L	Blade guard D1000mm Assy	531 11 83-25	Q	Nipple 1312
505 15 31-01	L	Blade guard D1240mm Assy	531 11 83-37	B	Adapter 1/8"
505 18 64-01	K	Parallell pin	531 11 90-14	Q	Hose clamp 13-20
505 18 65-01	K	Screw	531 11 90-15	Q	Hose clamp 15-24
505 18 66-01	K	Stop screw	531 11 90-39	C	Bearing washer AS 3552
505 18 74-01	K	Blade guard guide	531 11 90-42	C	Bearing AXK 3552
505 21 61-01	E	Flange, inner	531 11 90-45	F	Ball D20xM5
505 21 62-01	E	Hub	531 11 90-63	A	Grease nipple
505 21 63-01	E	Radial seal 60x72x4	531 11 90-65	P	Wrench 18 mm
505 21 64-01	E	Radial seal 50x62x7 RF	531 11 90-98	F	Spring LBR 45F
505 21 65-01	E	Lock ring SGA 50	531 11 90-99	F	Ball 6 mm
505 21 76-01	E	Blade flange compl.	531 11 91-08	P	Grease gun
505 21 76-02	E	Blade flange 60mm compl.	531 11 91-45	B	Washer, copper
505 21 80-01	E	Flange, inner 130	531 11 91-46	BG	Bearing washer
505 21 81-01	E	Blade flange 130 compl.	531 11 91-49	BFG	Bearing AXK 1024
505 25 52-01	G	Cylindrical pin	531 11 91-50	B	Bearing
505 40 73-01	F	Hydraulic motor WS 463	531 11 91-52	H	Plug
505 45 50-01	F	Plug	531 11 91-55	B	Bearing Nk 19/16
505 55 56-01	A	Plug	531 11 91-58	B	Shim 23.35x1
510 19 56-01	P	Husqvarna oil 150 1dl	531 11 91-65	LM	Blind rivet 4x12 st/st
522 73 40-01	L	Outer side 800mm LEFT compl	531 11 91-81	K	Washer 10.5x22
522 73 41-01	L	Outer side 800mm RIGHT compl	531 11 91-83	DHJ	Washer 13x24x2
522 73 43-01	L	Centre section 800mm compl	531 11 91-85	DF	Sealing ring 1/2"
522 73 44-01	L	Outer side 1000mm LEFT compl	531 11 91-88	B	Radial seal GHH2 28x20,5x3,2
522 73 45-01	L	Outer side 1000mm RIGHT cpl	531 11 92-02	EH	Screw M6S 12x25
522 73 47-01	L	Centre section 1000mm compl	531 11 92-03	HJ	Screw M6S 12x30
522 73 48-01	L	Outer side 1240mm LEFT compl	531 11 92-18	M	Screw M6S 8x25
522 73 49-01	L	Outer side 1240mm RIGHT cpl	531 11 92-28	BD	Screw MC6S 5x14
522 73 51-01	L	Centre section 1240mm compl	531 11 92-35	H	Screw MC6S 8x14
531 11 30-37	Q	Water hose with valve	531 11 92-49	A	Nut
531 11 30-45	H	Track 1,2m complete	531 11 92-60	L	Washer 5x19x1

No.	Pos.	Description	No.	Pos.	Description
531 11 92-62	F	O-ring 18,3x2,4	531 12 20-49	D	Sealing plug
531 11 92-70	F	O-ring 24,2x3	531 12 20-70	H	Safety stop
531 11 92-74	D	O-ring 29,2x3	531 12 20-84	F	Valve block
531 11 92-77	B	O-ring 31,4x1,6	531 12 20-85	F	Valve cover
531 11 92-80	B	O-ring 43x1,6	531 12 20-86	F	Retracting block
531 11 92-90	E	O-ring 61,6x2,4	531 12 20-87	F	Shift valve
531 11 92-93	F	O-ring 80x1,6	531 12 21-06	F	Check valve plug
531 11 93-07	C	Key 6x6x14	531 12 21-07	F	Plunge
531 11 93-19	F	Shaft seal SCN 18x30x6	531 12 21-08	B	Cover
531 11 93-26	N	Washer	531 12 21-18	H	Clamping washer
531 11 93-39	F	Plug VSTI M14X1,5	531 12 21-24	H	Rack
531 11 93-40	F	Plug VSTI R1/2	531 12 21-25	H	Guide
531 11 93-50	H	Screw MF6S 4x12 12.9	531 12 21-68	N	Guide
531 11 93-53	M	Screw MLC6S 6x12	531 12 21-82	K	Guide wheel shaft
531 11 93-60	D	O-ring 133,0x1,78	531 12 21-82	K	Guide wheel shaft, upper
531 11 93-64	DJ	Spring	531 12 21-83	K	Wheel
531 11 93-65	F	O-ring 11,3x2,4 NBR 90	531 12 22-43	M	Locking feather Right
531 11 93-75	C	X-Ring 114,0x1,78	531 12 22-44	M	Locking feather left
531 11 93-76	C	O-Ring 94,97x1,78	531 12 22-45	M	Lock cone
531 11 93-89	G	Screw	531 12 22-51	Q	Wear hose
531 11 94-13	LM	Handle Bladeguard	531 12 22-60	M	Top holder
531 11 94-18	J	Screw M6S 12x120	531 12 22-80	C	Friction plate pivoting arm
531 11 94-20	J	O-ring 40x2	531 12 23-38	K	Spacer
531 11 94-26	GMN	Screw K6S 6x16 10.9 fzb	531 12 23-45	L	Splash guard compl.
531 11 94-32	N	Plug	531 12 23-49	L	Splash shield
531 11 94-39	C	Bearing HK 3520	531 12 23-57	J	Friction plate
531 11 94-40	C	Washer AS 5070	531 12 23-58	K	Guide wheel shaft, lower
531 11 94-41	D	Bearing 16005	531 12 23-85	N	Bar
531 11 94-42	G	Bearing 6001-2RSH	531 12 23-88	N	Cramp
531 11 94-43	C	Bearing 16007	531 12 23-90	N	Guide plate
531 11 94-44	D	Bearing 61909-2RS1	531 12 24-54	J	Mounting bracket
531 11 94-45	D	Bearing 61816	531 12 24-55	J	Shaft
531 11 94-47	D	Shaft seal BA 50x65x7	531 12 24-56	J	Link to track-holder
531 11 94-48	D	O-ring 101,34x1,78	531 12 24-57	J	Track holder
531 11 94-51	D	O-ring 74,5x3	531 12 24-58	J	Clamping plate
531 11 94-53	G	Levell	531 12 24-59	J	Clamping plate nut
531 11 94-54	G	Spring	531 12 24-60	J	Breaking plate
531 11 94-57	G	Bearing bushing	531 12 30-00	A	House
531 11 94-99	D	O-ring 69,5x3	531 12 30-01	G	Saw carriage
531 11 95-00	C	O-ring 61x1,6	531 12 30-02	G	Socket
531 11 95-04	C	O-ring 71,12x2,62	531 12 30-03	G	Holder right
531 11 95-26	M	Edge list 3,3m	531 12 30-04	G	Holder left
531 11 95-31	P	Water level	531 12 30-05	G	Concentric shaft
531 11 95-32	P	Ratchet wrench	531 12 30-06	G	Excentric shaft
531 11 95-33	P	Wrench 16mm	531 12 30-07	G	Guide wheel
531 11 95-34	P	Socket 18mm	531 12 30-08	G	Nut for guide wheel
531 11 95-35	P	Allen key 10mm	531 12 30-09	G	Handle
531 11 95-36	P	Allen key 8mm	531 12 30-10	G	Bar
531 11 95-37	P	Allen key 6mm	531 12 30-11	G	Excentric locking shaft
531 11 95-38	P	Allen key 5mm	531 12 30-12	G	Locking clamp
531 11 95-39	P	Allen key 4mm	531 12 30-13	G	Sprint
531 11 95-40	P	Allen key 3mm	531 12 30-14	G	Excentric bushing
531 11 95-41	P	Socket 19mm	531 12 30-15	G	Feeding shaft
531 11 95-42	A	Screw	531 12 30-16	G	Shaft holder
531 11 95-53	Q	Cleaning brush	531 12 30-17	G	Transfer gear
531 11 95-81	E	Bearing 61810-2RS	531 12 30-18	G	Nut for shaft
531 11 95-86	J	Screw MRX 3x5	531 12 30-19	C	Arm shaft
531 11 95-88	G	Seeger circlip SGA 11	531 12 30-20	A	Wear plate
531 11 95-89	K	Screw K6S 6x20 10.9 fzb	531 12 30-21	C	Feeding gear, arm
531 11 95-96	B	O-ring 41x1	531 12 30-22	C	Feeding gear, track
531 11 96-01	D	Shaft seal BASL 25x35x7	531 12 30-23	C	Longituinal feeding gear
531 12 13-44	F	Support washer	531 12 30-24	C	Tensioning nut
531 12 14-02	F	Valve lever hub	531 12 30-25	C	Cup spring
531 12 14-03	F	Valve lever	531 12 30-26	C	Friction plate
531 12 16-11	M	Knob	531 12 30-27	G	Bushing
531 12 20-27	H	Rack	531 12 30-30	D	Input gear
531 12 20-28	H	Rack	531 12 30-31	D	Stub gear
531 12 20-34	B	Thrust journal	531 12 30-32	D	Medial gear
531 12 20-43	H	Guide	531 12 30-33	E	Flange, outer
531 12 20-44	H	Guide	531 12 30-35	D	Blade shaft

No.	Pos.	Description	No.	Pos.	Description
531 12 30-36	D	Cover plate	734 11 63-01	DFH	Washer 8.4x16
531 12 30-40	C	Clutch plate	735 31 28-10	G	Seeger circlip SGH 28
531 12 30-41	D	Mounting plate	735 31 30-10	F	Seeger circlip SGH 30
531 12 30-43	D	Medial shaft	735 31 33-00	C	Seeger circlip SGA 35
531 12 30-44	D	Medial spacer	735 31 33-10	K	Seeger circlip SGH 35
531 12 30-46	D	Collar	738 21 05-00	D	Bearing
531 12 30-47	D	Collar plate	738 21 10-04	C	Bearing 6010-2RS1
531 12 30-48	E	60mm bushing	738 22 02-24	K	Bearing 6202-2RS1 C2
531 12 30-51	E	Plate for hub	740 38 18-01	B	Sealing ring 1/8
531 12 30-55	B	Cover plate	740 38 27-01	EQ	Sealing ring 1/4
531 12 30-56	E	Water block	740 38 34-01	Q	Sealing washer 3/8"
531 12 30-57	E	Water connection	740 42 07-00	E	O-ring 9,1x1,6
531 12 30-59	LM	Rail holder	740 42 14-00	G	O-ring 16,1x1,6
531 12 30-62	A	Saw handle	740 43 07-00	FH	O-ring 9,3x2,4
531 12 30-63	LM	Rail	740 43 09-00	BF	O-ring 11,3x2,4
531 12 30-66	K	Cover	740 43 11-00	D	O-ring 13,3x2,4
531 12 30-70	K	Handle	740 44 04-00	F	O-ring 19,2x3
531 12 30-71	K	Excentric shaft	740 44 05-00	E	O-ring 22,2x3
531 12 30-73	LM	Slide rail			
531 12 30-74	P	Pin socket			
531 12 30-75	H	Track holder			
531 12 30-76	H	Clamping plate			
531 12 30-86	LM	Rail holder 2			
531 12 30-87	N	Bracket			
531 12 30-91	N	Handle			
531 12 30-95	E	Water hose			
531 12 30-96	H	Coupling link			
531 12 30-97	H	Clamping washer			
531 12 31-00	B	Aluminium washer red			
531 12 31-03	B	Distance 20cc			
531 12 31-28	D	Seal for arm			
531 12 32-49	D	Arm housing			
531 14 20-25	F	Nipple 1/2"			
720 12 71-50	G	Cylindrical pin 4x18			
720 13 08-50	G	Cylindrical pin 5x16			
720 13 51-50	D	Cylindrical pin 6x16			
720 13 52-51	H	Cylindrical pin 6x18			
720 13 53-50	J	Cylindrical pin 6x20			
720 13 65-51	J	Cylindrical pin 6x50			
721 42 57-00	N	Spring pin 4x22			
721 42 58-00	F	Spring pin 4x25			
723 53 66-51	E	Screw MFS 6x12			
725 25 44-91	D	Screw M6S 12x60			
725 53 01-51	B	Screw MC6S 4x35 12.9			
725 53 41-01	K	Screw MC6S 5x50			
725 53 62-01	K	Screw MC6S M6x8			
725 53 64-01	H	Screw MC6S 6x10			
725 53 66-01	M	Screw MC6S 6x12			
725 53 68-01	GKLM	Screw MC6S 6x16			
725 53 70-01	G	Screw MC6S 6x20			
725 53 76-01	F	Screw MC6S 6x35			
725 53 78-01	F	Screw MC6S 6x40			
725 54 53-01	FG	Screw MC6S 8x25			
725 54 64-01	D	Screw MC6S 8x65			
725 62 85-01	D	Screw MF6S 4x6			
725 62 87-01	D	Screw MF6S 4x8			
725 63 27-51	AEFK	Screw MF6S 5x12 10.9			
725 63 30-51	KL	Screw MF6S 5x16 10.9			
725 63 66-51	DE	Screw MF6S 6x12 10.9			
725 63 68-51	ADKLM	Screw MF6S 6x16 10.9			
725 63 70-51	EKN	Screw MF6S 6x20 10.9			
725 64 47-51	E	Screw MF6S 8x12 10.9 fzb			
725 64 89-51	E	Screw MF6S 10x16 10.9			
728 72 89-05	C	Stop screw S6SS 4x10			
728 73 64-05	G	Stop screw S6SS 6x10			
731 43 20-01	GKN	Nut M10 low			
732 25 14-01	K	Nut M5 Nylock			
732 25 16-01	N	Nut M6			
732 25 22-71	DJ	Locking nut M12			
734 11 35-71	G	Washer			

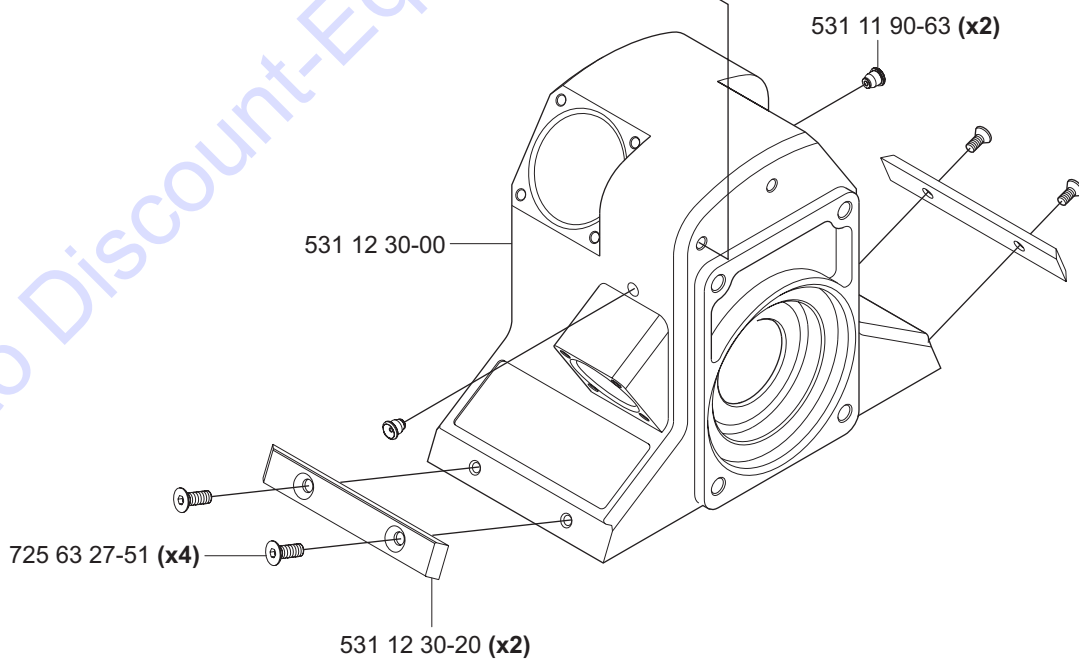
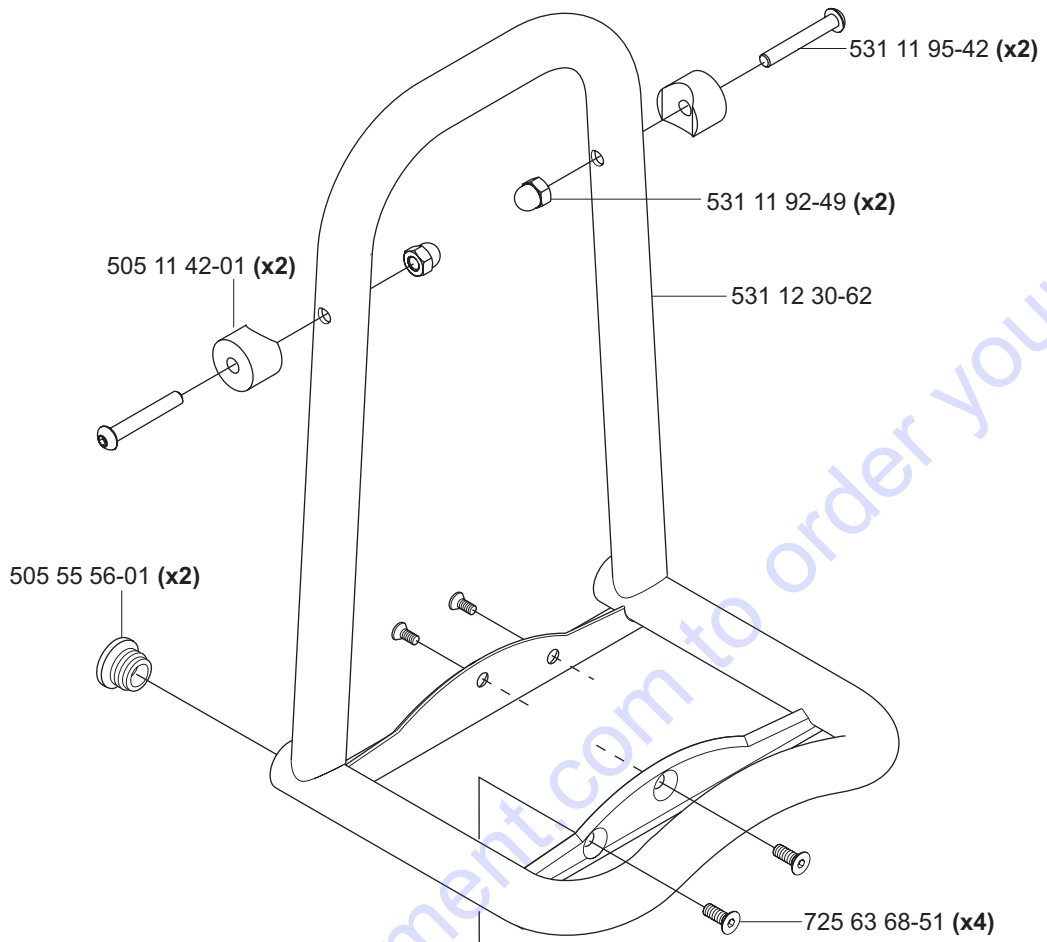

Go to Discount-Equipment.com to order your parts

**B** WS 463

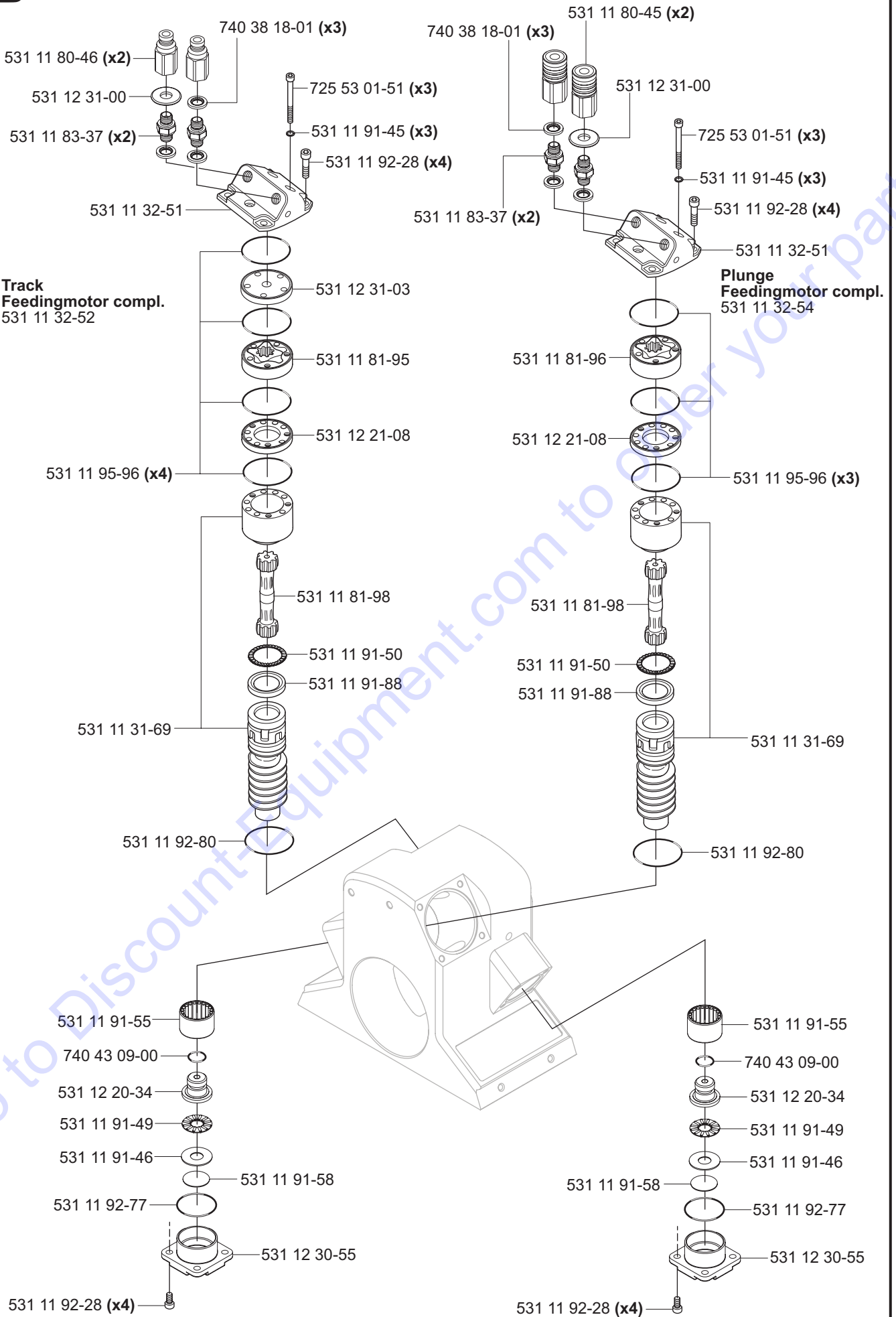

**C** WS 463

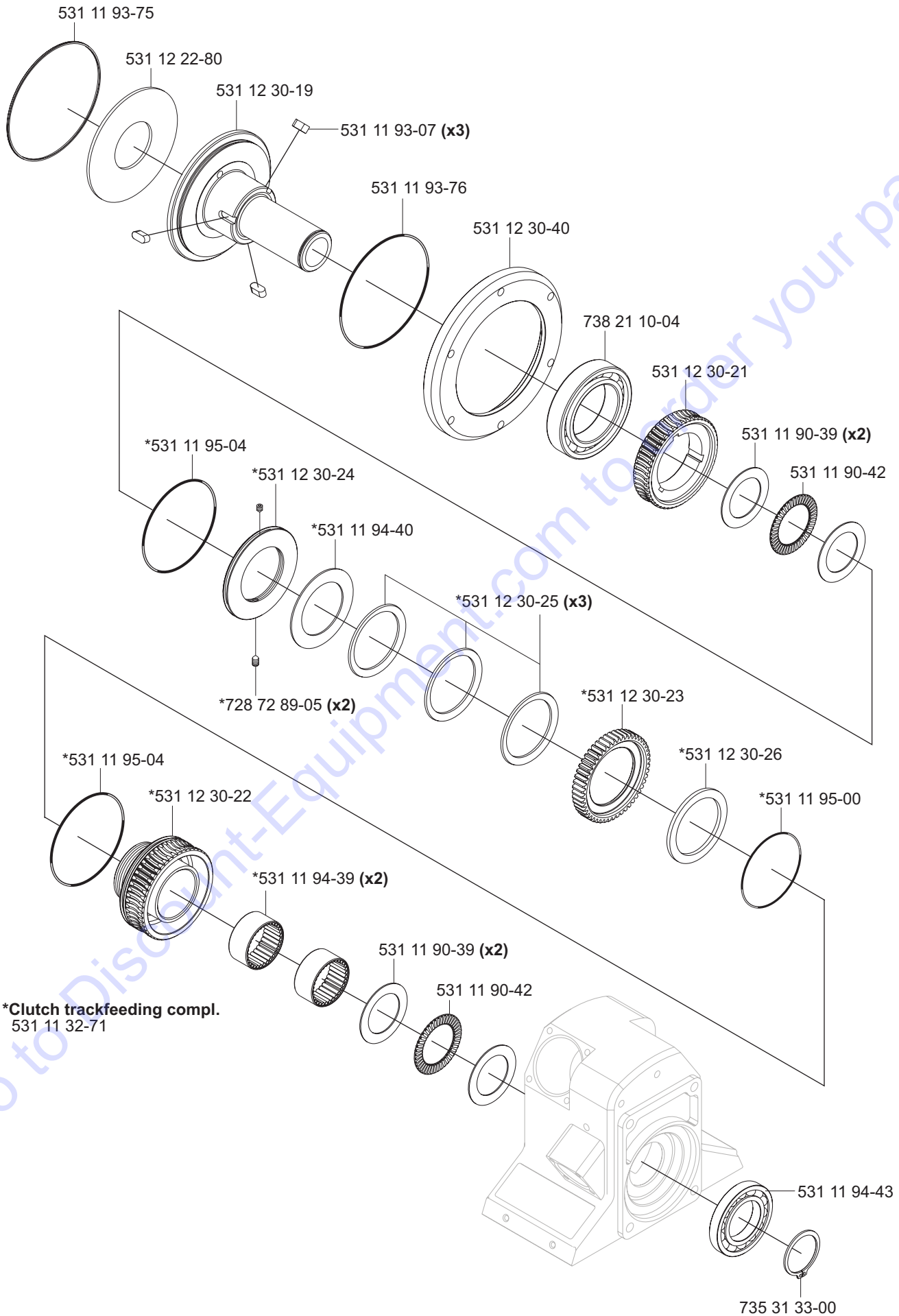



**D**

WS 463

Pivoting arm complete 531 11 32-44

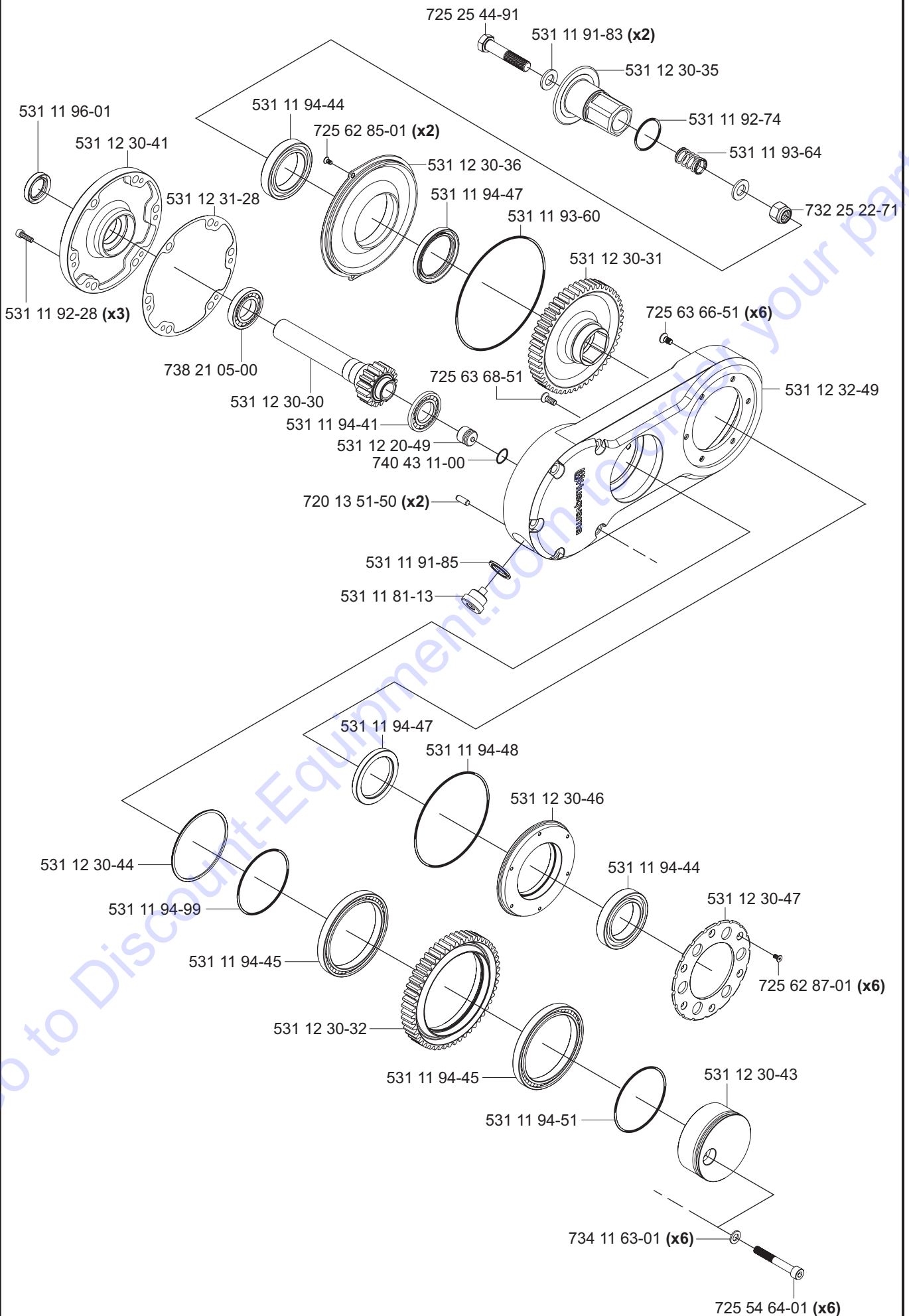

- Flange 1" complete      505 21 76-01
- Flange 60mm complete    505 21 76-02
- Flange 130 complete    505 21 81-01

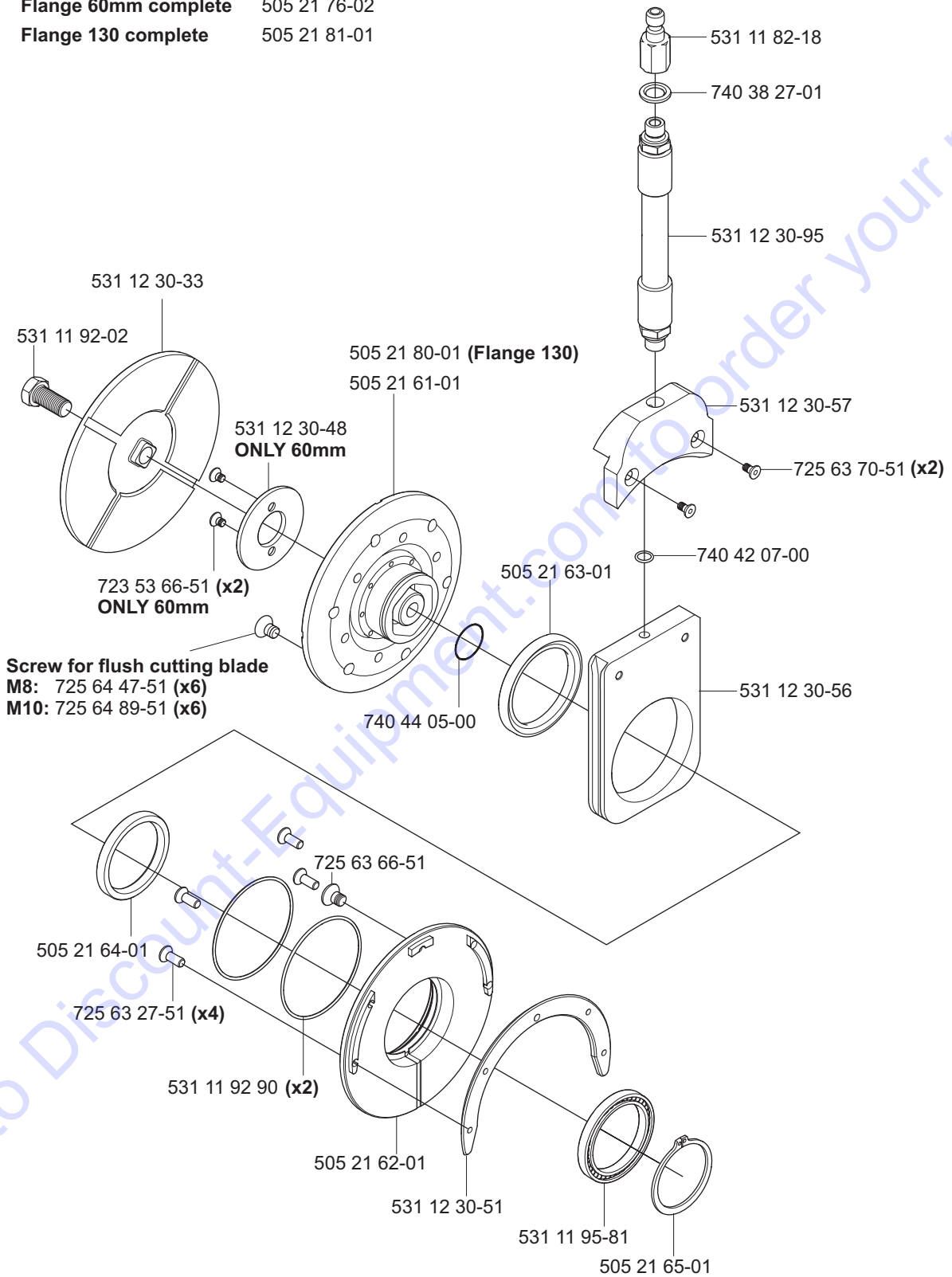

Go to Discount-Equipment.com to order your parts

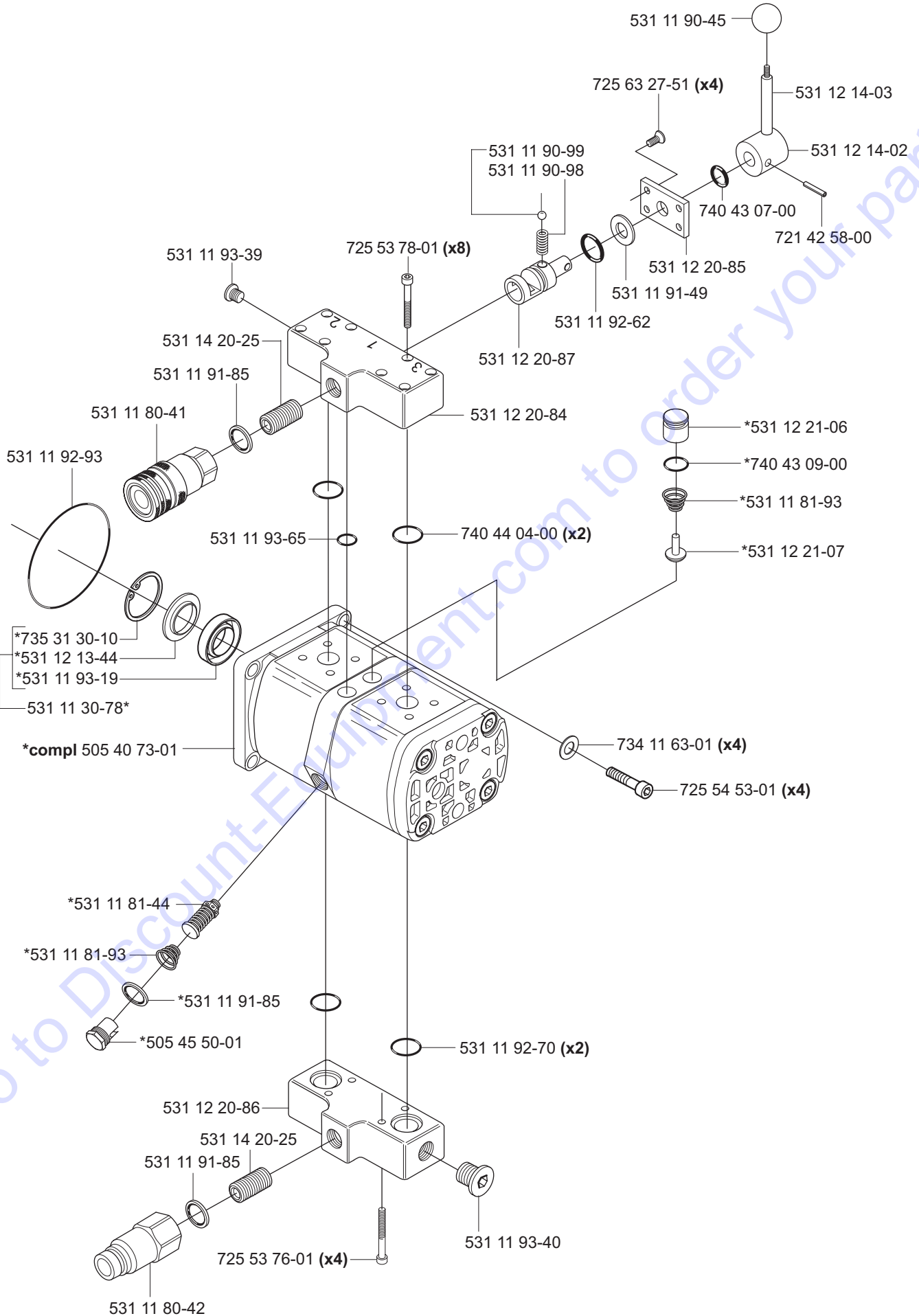
**F****WS 463****Hydraulic motor complete 531 11 32-55**



WS 463

Saw carriage 400 complete 505 22 69-01

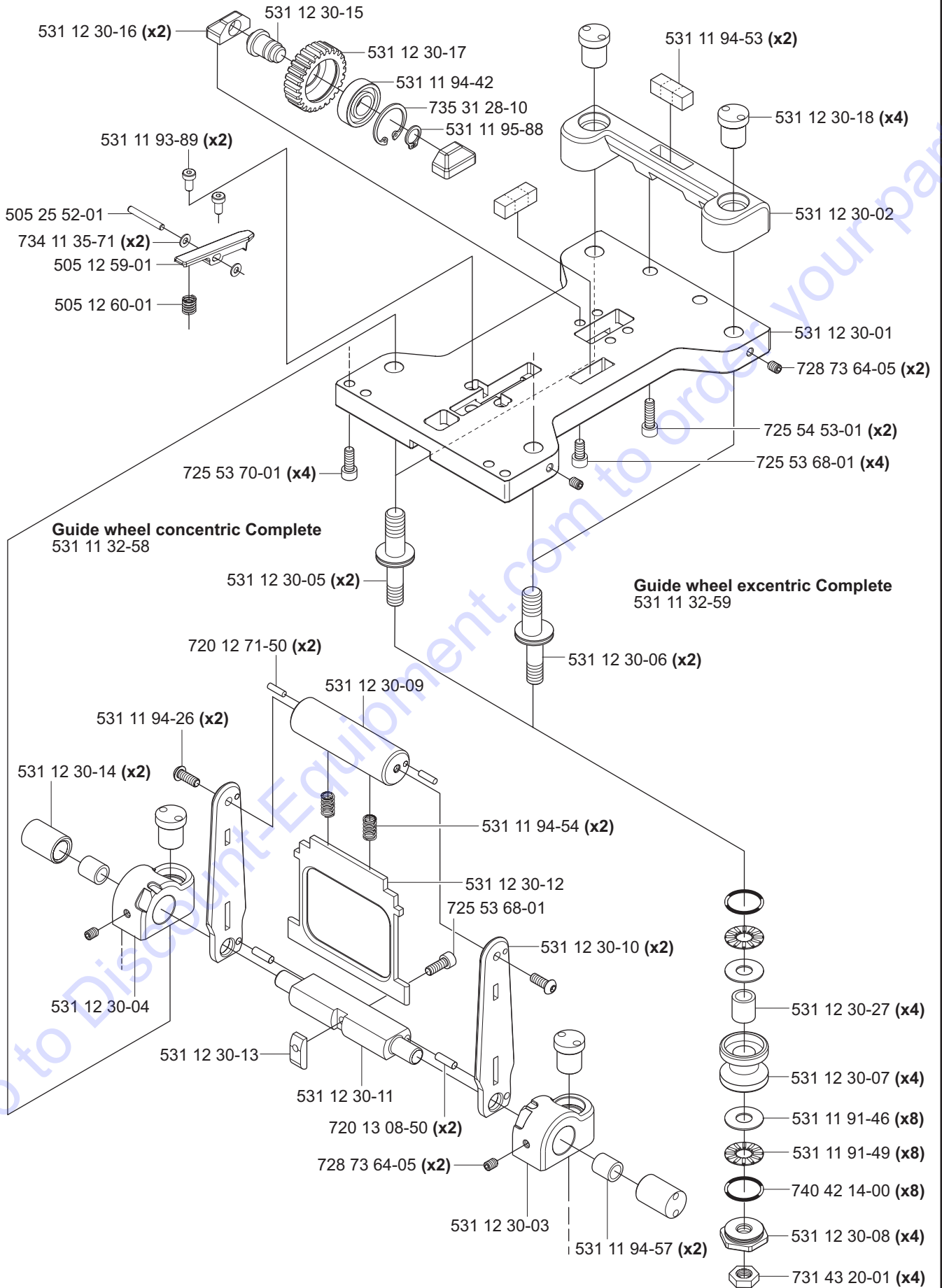

**H**

WS 463

**Track complete**

1.2m 531 11 30-45

2.0m 531 11 30-46

2.2m 531 11 30-47

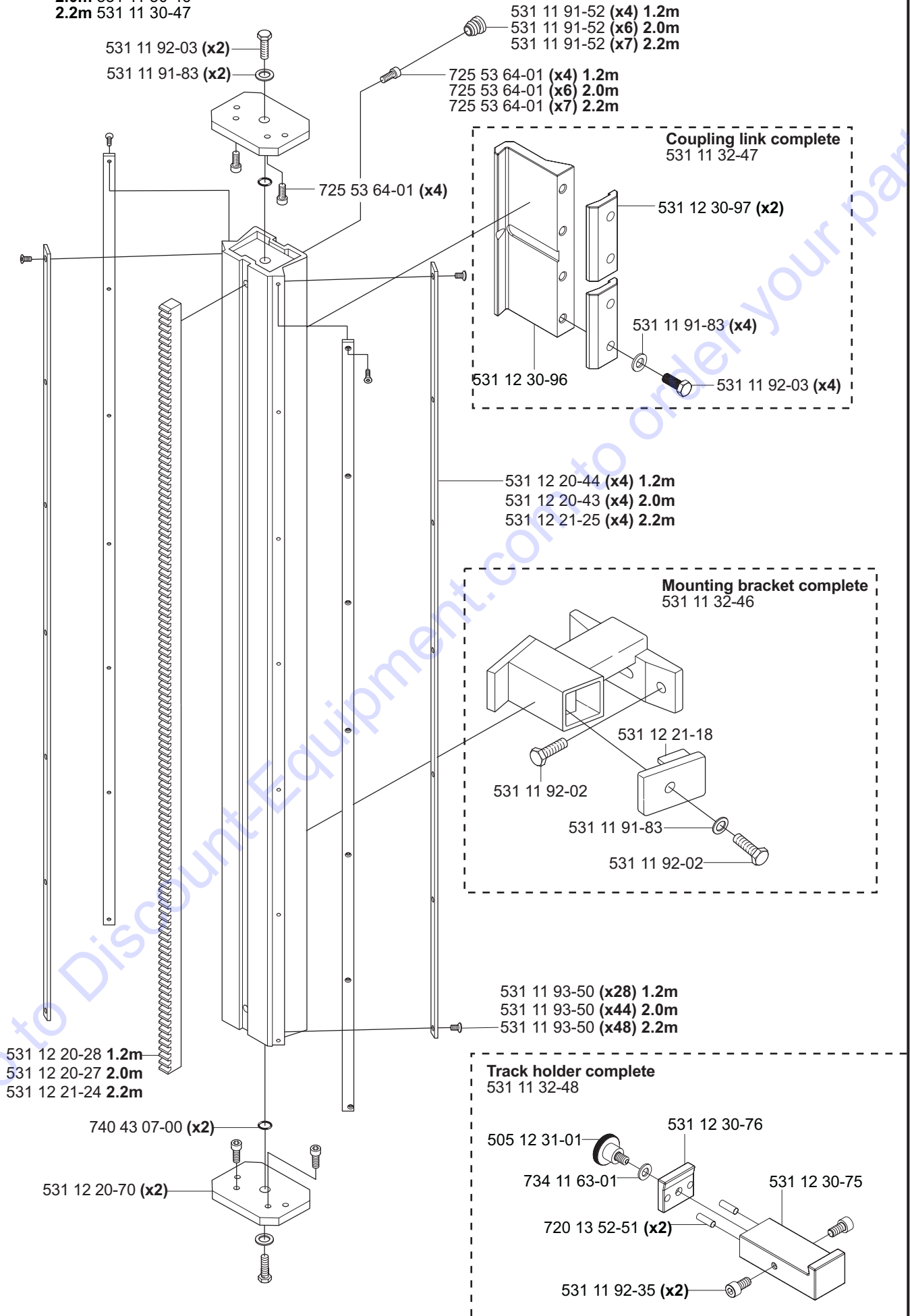

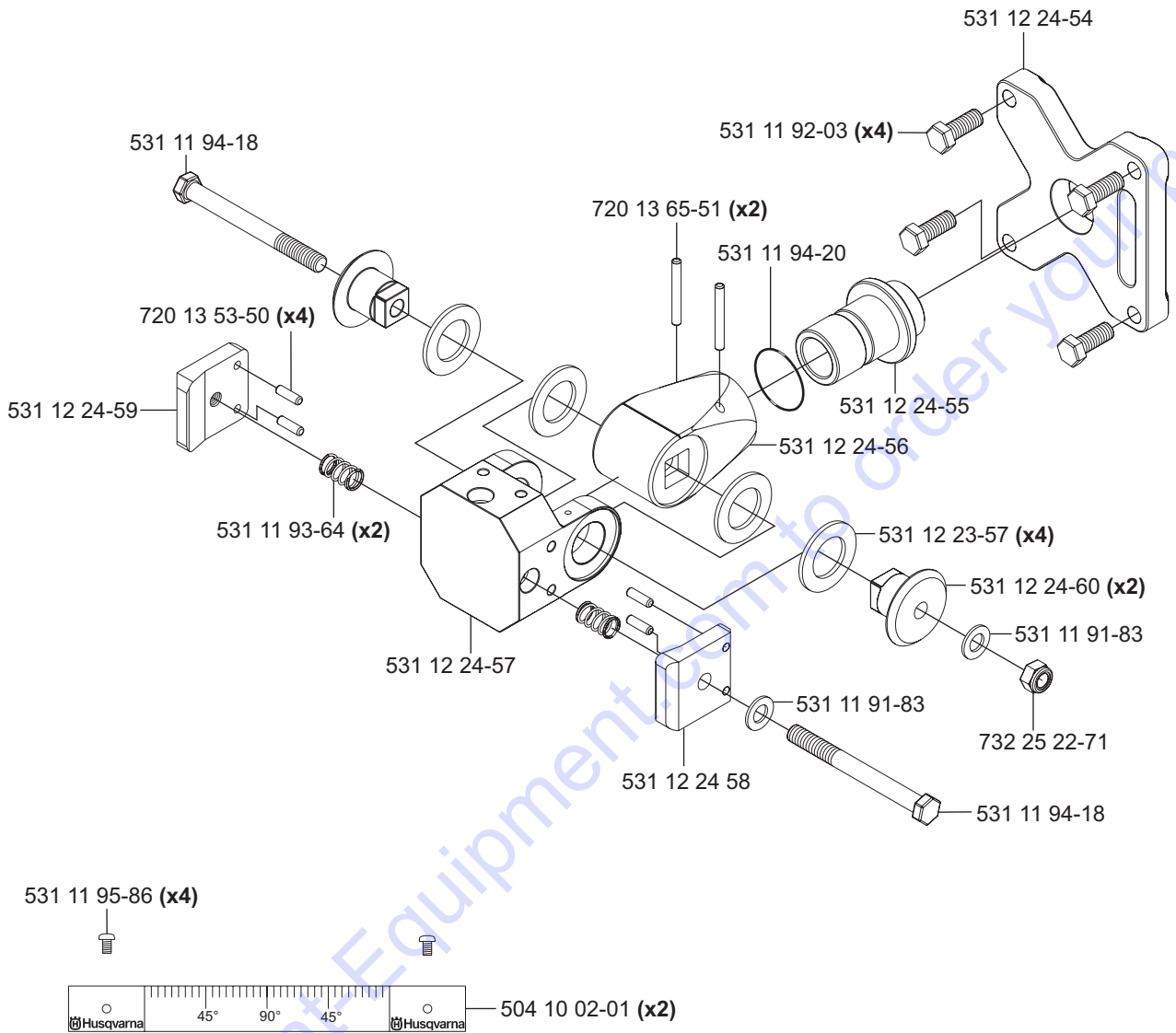
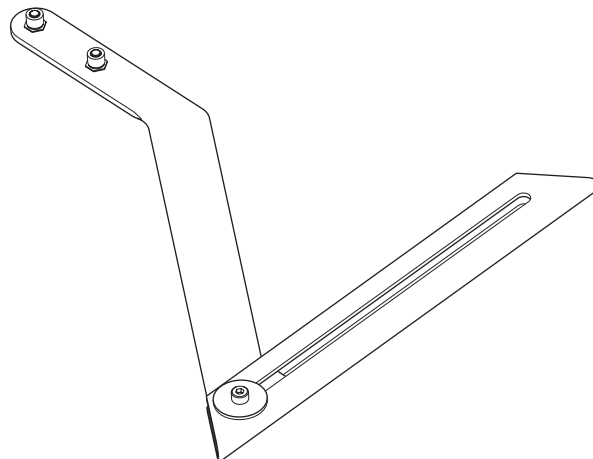
**J****WS 463****Mounting bracket Universal  
compl. 531 11 32-00****Measure rod complete 531 11 32-65**

**K**

WS 463

Blade guard guide Complete 505 18 74-01

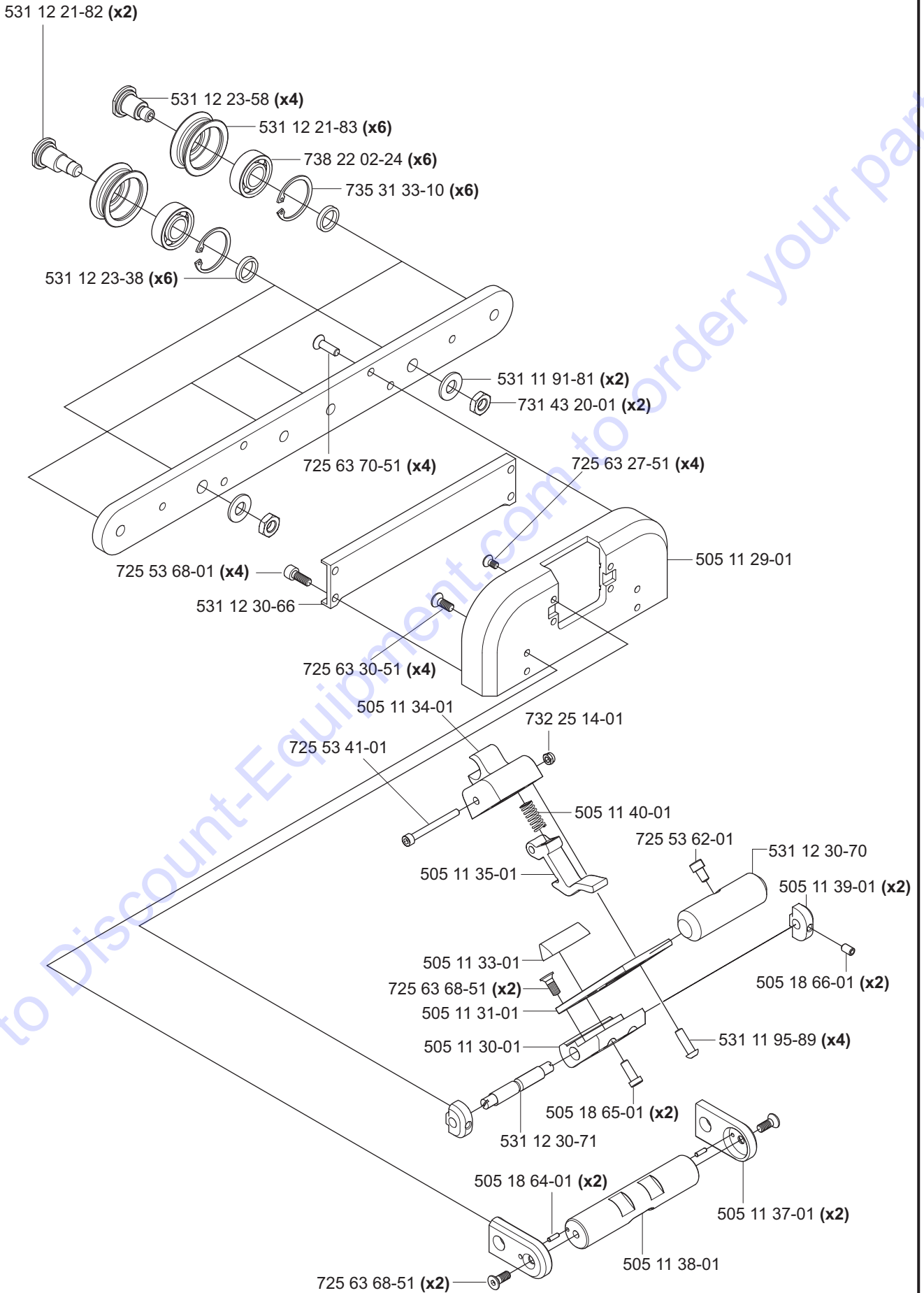

**L****WS 463****Blade guard Complete**

800mm 505 15 29-01 725 53 68-01(x2)

1000mm 505 15 30-01

1240mm 505 15 31-01

505 12 08-01

**Outer side, RIGHT compl.**

800mm 522 73 41-01

1000mm 522 73 45-01

1240mm 522 73 49-01

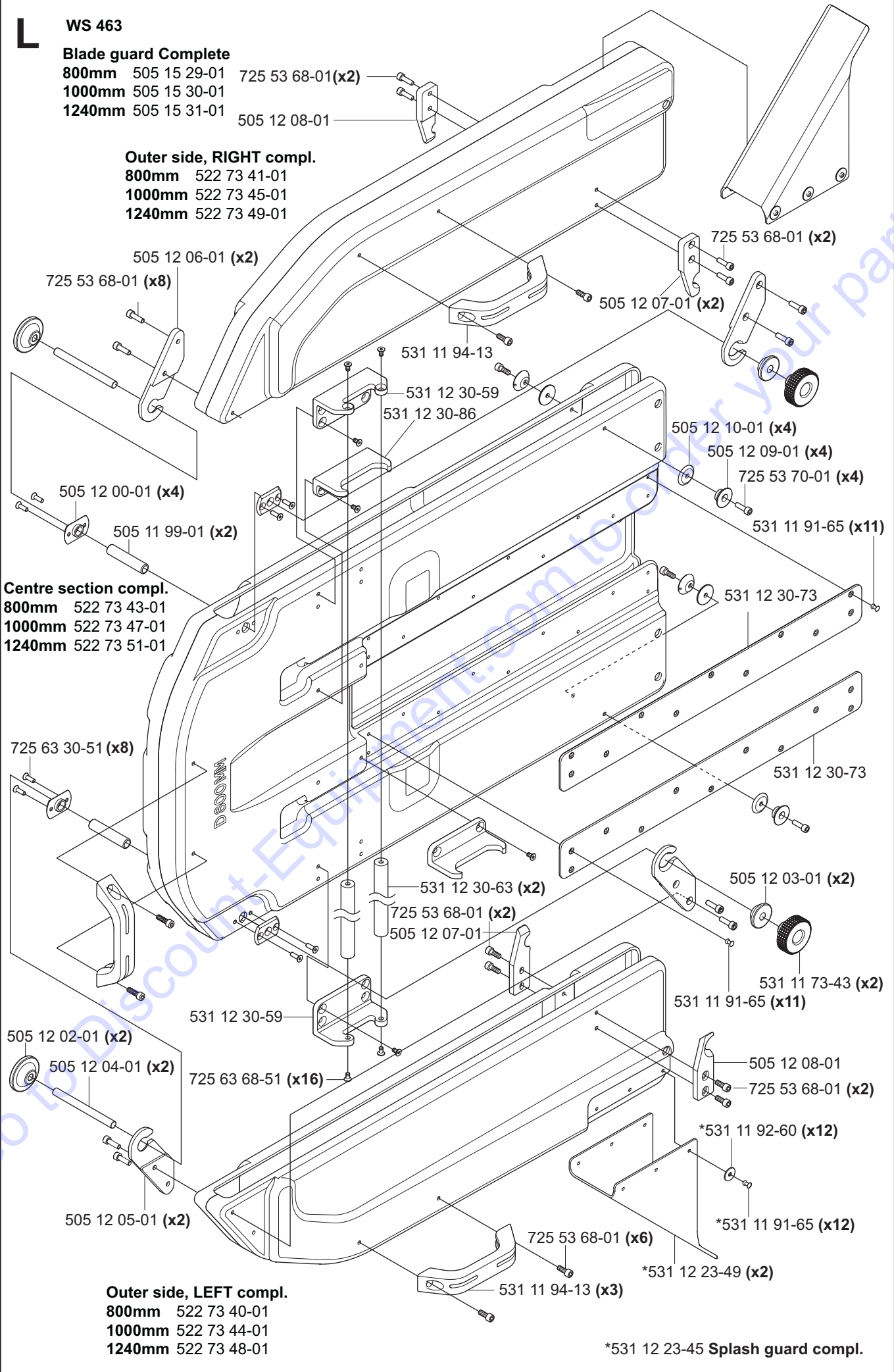
**Centre section compl.**

800mm 522 73 43-01

1000mm 522 73 47-01

1240mm 522 73 51-01

**Outer side, LEFT compl.**

800mm 522 73 40-01

1000mm 522 73 44-01

1240mm 522 73 48-01



**M****WS 463****Flush blade guard compl.**

800mm 504 00 50-01

1000mm 504 00 52-01

1240mm 504 00 53-01

**Outer side, right compl.**

800mm 501 37 29-01

1000mm 501 37 31-01

1240mm 501 37 33-01

**Edge list 3,3 Meter**

531 11 95-26

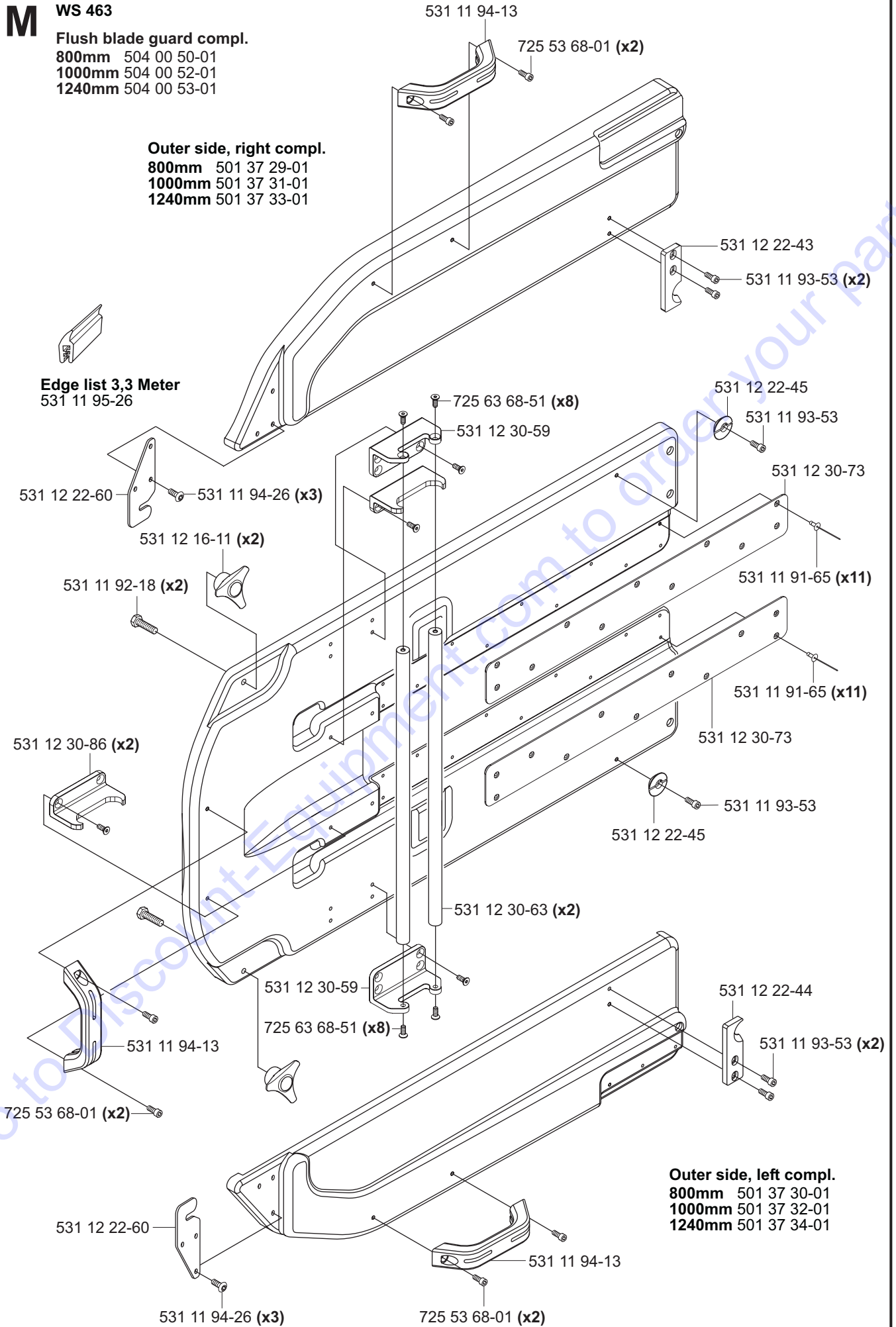

**N**

WS 463

ONLY Bladeguard and Flush cut guard 1240mm

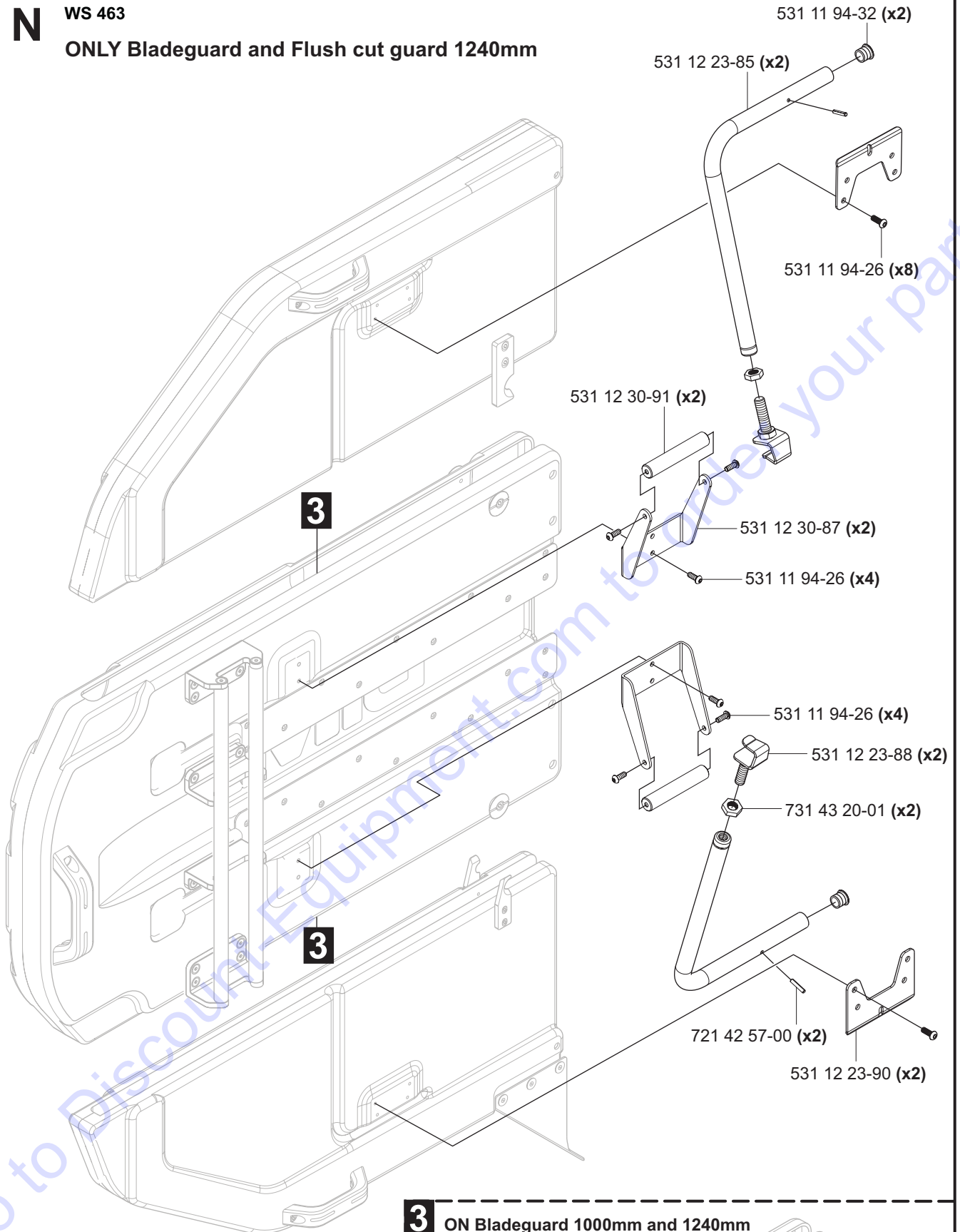

**3** ON Bladeguard 1000mm and 1240mm

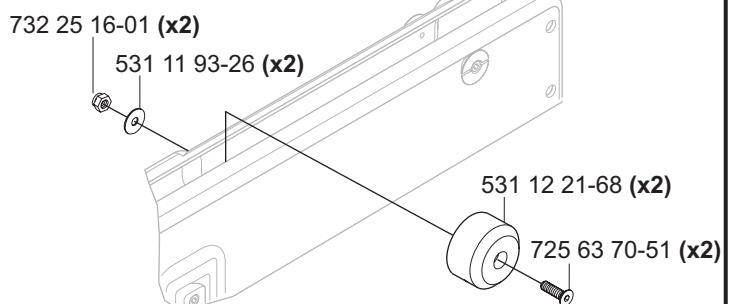

**P**

**WS 463**

**Toolkit compl 501 37 52-01**

504 10 29-01

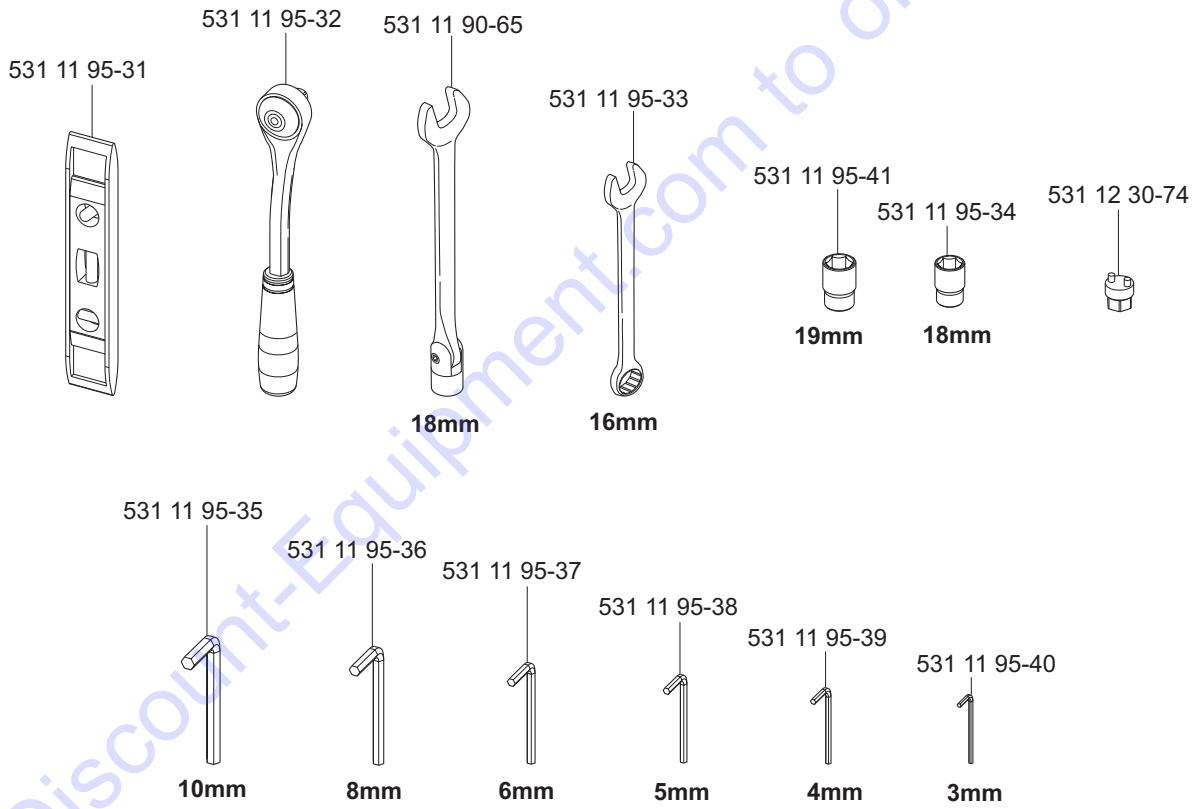
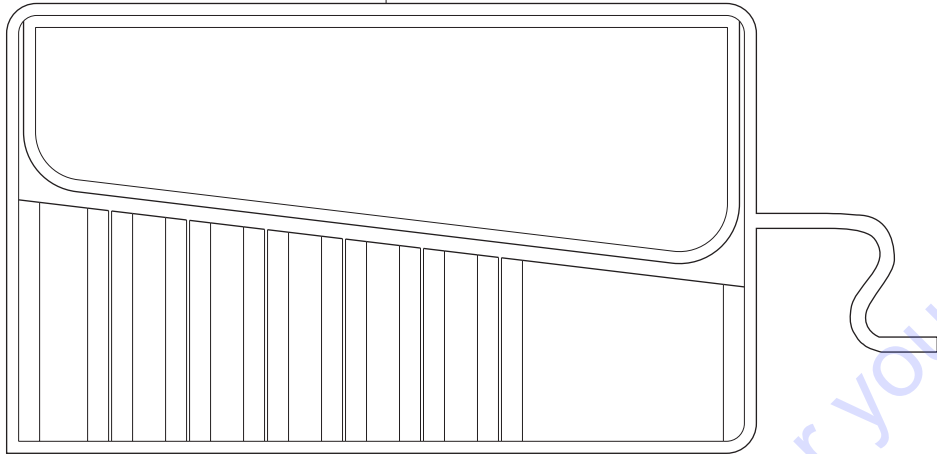

510 19 56-01



531 11 91-08



**Q**

**WS 463**

**Water hose with valve complete 531 11 30-37**

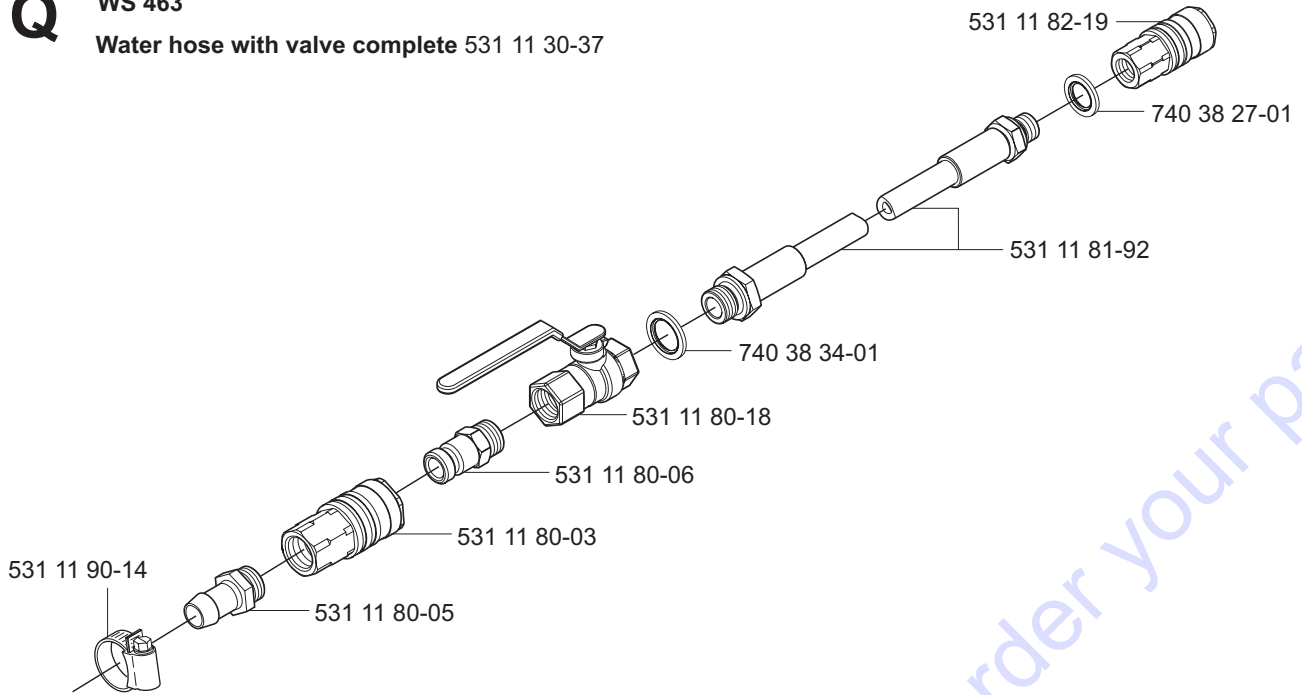

**WS 463 Wear hose, water complete 531 11 33-43**

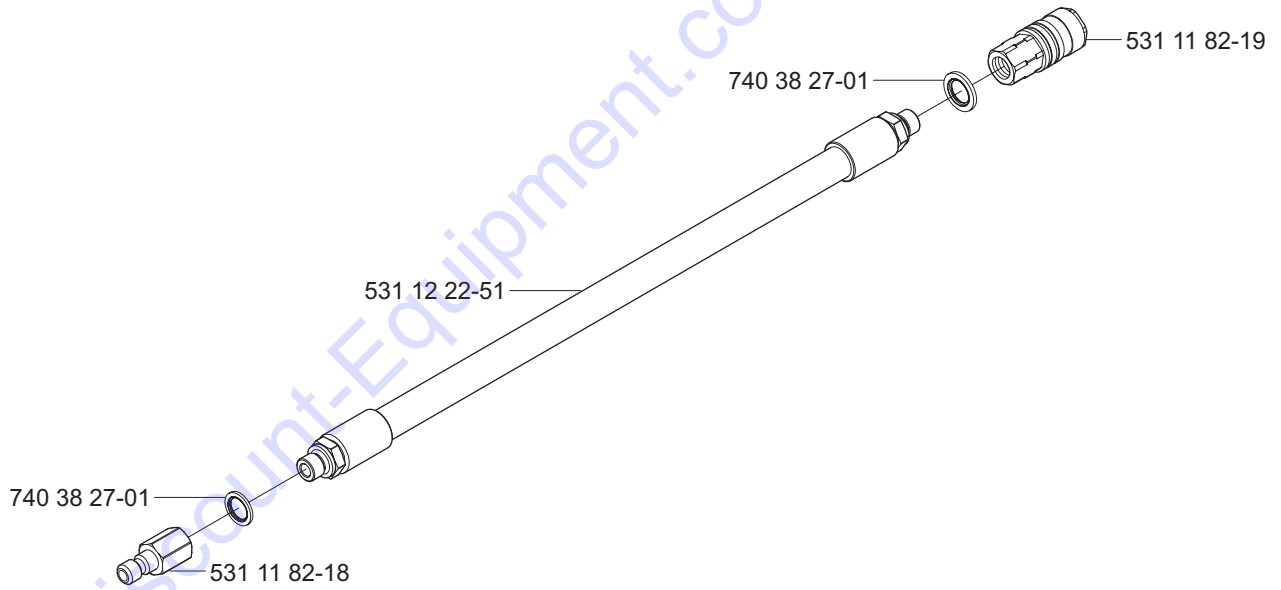

**Cleanig brush complete 531 11 32-68**

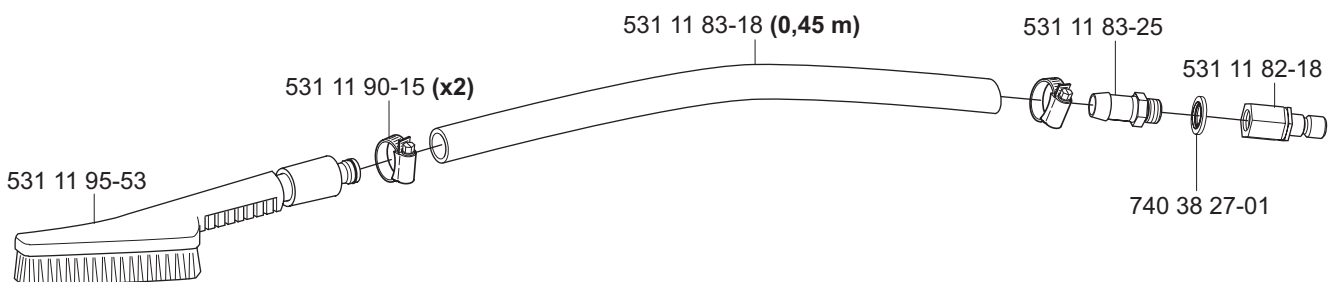

# PARTS FINDER

**Search Website  
by Part Number**



**Search Manual  
Library For Parts  
Manual & Lookup Part  
Numbers – Purchase  
or Request Quote**

**Search Manuals**

Enter your information to help us find the right parts manual for your equipment.

\* Brand:

\* Model:

\* Serial:

\* Part Number:

SEARCH

**Can't Find Part or  
Manual? Request Help  
by Manufacturer,  
Model & Description**

**Parts Order Form**

Please fill in the following information to help us find the right part for your equipment.

Manufacturer:	<input type="text"/>
Model:	<input type="text"/>
Description:	<input type="text"/>
Part Number:	<input type="text"/>
Quantity:	<input type="text"/>
Notes:	<input type="text"/>

REQUEST HELP

Discount-Equipment.com is your online resource for quality parts & equipment.

Florida: **561-964-4949** Outside Florida TOLL FREE: **877-690-3101**

**Need parts?**

Click on this link: <http://www.discount-equipment.com/category/5443-parts/> and choose one of the options to help get the right parts and equipment you are looking for. Please have the machine model and serial number available in order to help us get you the correct parts. If you don't find the part on the website or on one of the online manuals, please fill out the request form and one of our experienced staff members will get back to you with a quote for the right part that your machine needs.

We sell worldwide for the brands: Genie, Terex, JLG, MultiQuip, Mikasa, Essick, Whiteman, Mayco, Toro Stone, Diamond Products, Generac Magnum, Airman, Haulotte, Barreto, Power Blanket, Nifty Lift, Atlas Copco, Chicago Pneumatic, Allmand, Miller Curber, Skyjack, Lull, Skytrak, Tsurumi, Husquvarna Target, Stow, Wacker, Sakai, Mi-T-M, Sullair, Basic, Dynapac, MBW, Weber, Bartell, Bennar Newman, Haulotte, Ditch Runner, Menegotti, Morrison, Contec, Buddy, Crown, Edco, Wyco, Bomag, Laymor, EZ Trench, Bil-Jax, F.S. Curtis, Gehl Pavers, Heli, Honda, ICS/PowerGrit, IHI, Partner, Imer, Clipper, MMD, Koshin, Rice, CH&E, General Equipment, Amida, Coleman, NAC, Gradall, Square Shooter, Kent, Stanley, Tamco, Toku, Hatz, Kohler, Robin, Wisconsin, Northrock, Oztec, Toker TK, Rol-Air, APT, Wylie, Ingersoll Rand / Doosan, Innovatech, Con X, Ammann, Mecalac, Makinex, Smith Surface Prep, Small Line, Wanco, Yanmar