

WS 440 HF

Reservdelar

Spare parts

Ersatzteile

Pieces de rechange

Piezas de repuesto

Ricambi

Peças sobresselente



PARTS FINDER

**Search Website
by Part Number**



**Search Manual
Library For Parts
Manual & Lookup Part
Numbers – Purchase
or Request Quote**

Search Manuals

Enter your information to help us find the right parts manual for your machine.

* Brand:

* Model:

* Serial:

* Part Number:

SEARCH

**Can't Find Part or
Manual? Request Help
by Manufacturer,
Model & Description**

Parts Order Form

Please fill in the following information to help us find the right part for your machine.

Manufacturer:	<input type="text"/>
Model:	<input type="text"/>
Description:	<input type="text"/>
Part Number:	<input type="text"/>
Quantity:	<input type="text"/>
Notes:	<input type="text"/>

Submit

Discount-Equipment.com is your online resource for quality parts & equipment.

Florida: **561-964-4949** Outside Florida TOLL FREE: **877-690-3101**

Need parts?

Click on this link: <http://www.discount-equipment.com/category/5443-parts/> and choose one of the options to help get the right parts and equipment you are looking for. Please have the machine model and serial number available in order to help us get you the correct parts. If you don't find the part on the website or on one of the online manuals, please fill out the request form and one of our experienced staff members will get back to you with a quote for the right part that your machine needs.

We sell worldwide for the brands: Genie, Terex, JLG, MultiQuip, Mikasa, Essick, Whiteman, Mayco, Toro Stone, Diamond Products, Generac Magnum, Airman, Haulotte, Barreto, Power Blanket, Nifty Lift, Atlas Copco, Chicago Pneumatic, Allmand, Miller Curber, Skyjack, Lull, Skytrak, Tsurumi, Husquvarna Target, Stow, Wacker, Sakai, Mi-T-M, Sullair, Basic, Dynapac, MBW, Weber, Bartell, Bennar Newman, Haulotte, Ditch Runner, Menegotti, Morrison, Contec, Buddy, Crown, Edco, Wyco, Bomag, Laymor, EZ Trench, Bil-Jax, F.S. Curtis, Gehl Pavers, Heli, Honda, ICS/PowerGrit, IHI, Partner, Imer, Clipper, MMD, Koshin, Rice, CH&E, General Equipment, Amida, Coleman, NAC, Gradall, Square Shooter, Kent, Stanley, Tamco, Toku, Hatz, Kohler, Robin, Wisconsin, Northrock, Oztec, Toker TK, Rol-Air, APT, Wylie, Ingersoll Rand / Doosan, Innovatech, Con X, Ammann, Mecalac, Makinex, Smith Surface Prep, Small Line, Wanco, Yanmar

No.	Pos.	Description	No.	Pos.	Description
501 37 52-01	P	Tool kit	531 11 32-71	D	Clutch trackfeeding complete
504 10 02-01	J	Scale, angle	531 11 73-20	B	Contact pin 2,5mm ²
504 90 83-26	G	Cylindrical pin	531 11 81-13	E	Magnetic plug
504 90 94-14	"L1-2M1-2 N2-3"	Screw	531 11 82-18	FQ	Quick coupling, male 13411
505 11 29-01	K	Mount	531 11 82-19	AQ	Quick coupling, female 1300
505 11 30-01	K	Excentric	531 11 83-05	Q	Banjo screw
505 11 31-01	K	Handle bracket	531 11 83-18	Q	Waterhose black 1/2
505 11 33-01	K	Beam	531 11 83-25	Q	Hose nipple 1312
505 11 34-01	K	Snap locking	531 11 83-56	A	Adaptor 1/4"-1/4"
505 11 35-01	K	Hook	531 11 90-15	Q	Hose clamp 15-24
505 11 38-01	K	Handle	531 11 90-39	D	Bearing washer AS 3552
505 11 39-01	K	Shaft seat	531 11 90-42	D	Bearing AXK 3552
505 11 40-01	K	Spring	531 11 90-63	A	Grease nipple
505 11 53-01	Q	Hose	531 11 90-65	P	Wrench 18 mm
505 11 65-01	E	Pivoting arm complete	531 11 90-80	N1,3	Lock
505 12 59-01	G	Rocker lever	531 11 91-08	P	Grease gun
505 12 60-01	G	Spring	531 11 91-46	C	Bearing washer
505 14 35-01	A	Type plate	531 11 91-49	C	Bearing AXK 1024
505 18 64-01	K	Parallell pin	531 11 91-50	C	Bearing
505 18 65-01	K	Screw	531 11 91-52	H	Rubber plug GL16
505 18 66-01	K	Stop screw	531 11 91-55	C	Bearing NK 19/16
505 21 63-01	F	Radial seal 60x72x4	531 11 91-58	C	Shim 23.35x1
505 21 82-01	Q	Hose 1m	531 11 91-81	K	Washer 10.5x22
505 21 83-01	Q	Hose 8m	531 11 91-83	EHJ	Washer 13x24x2
505 21 84-01	Q	Hose	531 11 92-02	FH	Screw M6S 12x25
505 22 69-03	G	Carriage WS 400	531 11 92-03	HJ	Screw M6S 12x30
505 24 66-01	A	O-ring	531 11 92-28	C	Screw MC6S 5x14
505 24 70-01	B	Shackle	531 11 92-35	H	Screw MC6S 8x14
505 25 52-01	G	Paralel pin 4x32	531 11 91-49	A	Nut M6 cap
505 25 54-01	C	Gear box depth feed ASSY	531 11 92-74	E	O-ring 29,2x3
505 25 55-01	C	Gear box track feed ASSY	531 11 92-77	C	O-ring 31,4x1,6
505 50 58-01	B	Drain plug	531 11 92-82	C	O-ring 44,17x1,78
505 52 84-01	A	Ventilating valve	531 11 92-93	A	O-ring 80x1,6
505 52 89-01	B	Frame	531 11 93-02	C	Key 4x4x16
505 52 92-01	B	Contact housing	531 11 93-50	H	Screw MF6S 4x12 12.9
505 53 80-01	A	Quick coupling	531 11 93-60	E	O-ring 133,0x1,78
505 53 81-01	B	Console 3-pin	531 11 93-64	EJ	Spring 2547
505 53 86-01	C	Motor	531 11 93-70	B	O-ring 39,2x1,6
505 53 89-01	E	Bearing 608-2RSL	531 11 93-75	D	X-Ring 114,0x1,78
505 53 90-01	E	Bearing 61905-2RZ	531 11 93-76	D	O-Ring 94,97x1,78
505 55 56-01	A	Plastic plug	531 11 93-89	G	Screw MLC6S 5x10
506 06 85-01	E	Screw	531 11 94-20	J	O-ring 40x2
510 00 71-01	C	Cup spring	531 11 94-26	G	Screw K6S 6x16 10.9 fzb
510 11 15-01	K	Handle holder	531 11 94-39	D	Bearing HK 3520
516 04 33-01	A	Screw K6S 5x6	531 11 94-40	D	Bearing washer AS 5070
522 52 62-02	E	Medial gear	531 11 94-43	D	Bearing 16007
522 52 63-01	E	Medial shaft	531 11 94-46	C	Bearing washer AS 1528
522 52 64-01	E	Interlayer	531 11 94-51	E	O-ring 74,5x3
522 72 01-01	E	Gasket	531 11 94-53	G	Levell
522 82 77-01	P	Husqvarna oil 220 0,3 l	531 11 94-54	G	Spring
522 83 94-01	A	Bearing	531 11 94-56	H	Turning knob
522 83 95-01	A	Bearing	531 11 95-00	D	O-ring 61x1,6
522 93 07-01	B	Module 6-pin	531 11 95-04	D	O-ring 71,12x2,62
522 93 08-01	B	Contact pin 0,75mm ²	531 11 95-11	A	Screw K6S 8x16 10.9 fzb
525 45 52-01	P	Allen key set	531 11 95-17	F	Plug for M8
529 28 14-01	E	Bearing cage	531 11 95-24	N1,3	Screw
529 28 11-01	E	Lid	531 11 95-31	P	Water level to toolkit
529 28 12-01	E	Cover plate	531 11 95-32	P	Ratchet wrench to toolkit
529 28 17-01	E	Cover	531 11 95-33	P	Wrench 16mm to toolkit
529 28 20-02	E	Stub gear	531 11 95-34	P	Socket 18mm to toolkit
531 11 30-45	H	Track section 1,2 m	531 11 95-41	P	Socket 19mm to toolkit
531 11 30-46	H	Track section 2,0 m	531 11 95-44	A	Screw K6S 6x50
531 11 30-47	H	Track section 2,2 m	531 11 95-46	N1,3	Pin screw
531 11 32-00	J	Mounting bracket universal	531 11 95-53	Q	Cleaning brush
531 11 32-46	H	Mounting bracket WS 400	531 11 95-79	C	Screw
531 11 32-47	H	Coupling link compl.	531 11 95-86	J	Screw MRX M3x5
531 11 32-48	H	Track holder compl.	531 11 95-88	G	Seeger circlip SGA 11
531 11 32-65	J	Measure rod compl.WS 400	531 11 95-89	K	Screw K6S 6x20 10.9 fzb
531 11 32-68	Q	Cleaning brush with hose	531 11 95-93	F	Plug for M10
			531 11 96-01	E	Shaft seal 25x35x7

No.	Pos.	Description	No.	Pos.	Description
531 12 20-27	H	Gear rack 2,0m	574 43 13-01	F	Hub
531 12 20-28	H	Gear rack 1,2m	574 43 55-01	F	Water block
531 12 20-34	C	Thrust journal	574 44 39-01	E	Ring
531 12 20-43	H	Guide track section 2,0m	574 45 20-01	E	Bearing 16013
531 12 20-44	H	Guide track section 1,2m	574 45 21-01	E	Bearing 16011
531 12 20-49	E	Sealing plug	574 45 22-01	E	Radial seal
531 12 20-70	H	Safety stop	574 45 23-01	F	Radial seal 50x62x5
531 12 21-18	H	Clamping washer	574 45 24-01	E	O-ring 45x1,6
531 12 21-24	H	Gear rack 2,2 m	574 45 25-01	DF	O-ring 75x2
531 12 21-25	H	Guide track section 2,2 m	574 45 26-01	E	O-ring 91,7x1,78
531 12 21-68	M1N2	Block	574 45 27-01	F	Bearing
531 12 21-69	M1N2	Block	574 45 29-01	BE	O-ring 110,7x1,78
531 12 21-82	K	Guide wheel shaft, upper	574 45 30-01	E	O-ring 56,87x2,62
531 12 21-83	K	Wheel	574 45 32-01	E	Lock ring
531 12 22-80	D	Friction plate pivoting arm	574 61 87-01	D	Arm shaft
531 12 23-38	K	Spacer	574 61 97-01	D	Key 6x6x14
531 12 23-57	J	Friction plate	574 82 95-01	F	Blade flange compl.
531 12 23-58	K	Guide wheel shaft, lower	574 82 95-02	F	Blade flange 60mm compl.
531 12 24-54	J	Mounting bracket	574 82 95-03	F	Blade flange 130 compl.
531 12 24-55	J	Shaft	575 25 82-01	E	Pivoting arm
531 12 24-56	J	Link to spring-holder	575 33 54-01	B	Cover
531 12 24-57	J	Track-holder	575 39 41-01	B	Gasket
531 12 24-58	J	Clamping-plate	576 65 89-01	J	Support screw
531 12 24-59	J	Clamping-plate, nut	577 41 35-01	N3	Gable section flush Right cpl.
531 12 24-60	J	Brake plate	577 44 55-01	N1,3	Guide rail
531 12 30-09	G	Handle	577 48 48-01	"L1-2M1-2 N2-3"	Hitch
531 12 30-10	G	Bar	577 48 49-01	"L1-2M1-2 N2-3"	Hitch
531 12 30-11	G	Excentric locking shaft	577 48 53-01	L1M1N1	Turning knob
531 12 30-12	G	Locking clamp	577 48 56-01	L1M1N1	Washer
531 12 30-13	G	Sprint	577 53 16-01	F	Stop washer
531 12 30-15	G	Feeding shaft	577 53 22-01	F	Flange, inner
531 12 30-16	G	Shaft holder	577 53 28-01	F	Flange, inner 130
531 12 30-17	G	Transfer gear	577 53 29-01	F	Screw MC6S 2,5x5
531 12 30-20	A	Wear plate	577 61 29-01	L1M1N2	Link
531 12 30-21	D	Feeding gear, arm	577 61 30-01	"L1-2M1-2 N2-3"	Link
531 12 30-22	D	Feeding gear, track	577 61 31-01	"L1-2M1-2 N2-3"	Link
531 12 30-23	D	Longitudinal feeding gear	577 61 36-01	L1	End cover
531 12 30-25	D	Cup spring	577 61 37-01	M1	End cover
531 12 30-26	D	Friction plate	577 61 38-01	N2	End cover
531 12 30-28	C	Feeding screw	577 61 40-01	L1M1N1	Spray guard
531 12 30-33	F	Flange, outer	577 65 97-01	L1	Bladeguard 800
531 12 30-35	E	Blade shaft	577 65 98-01	L1	Centre section 800 complete
531 12 30-40	D	Clutch plate	577 66 00-01	L1	Gable section 800 complete
531 12 30-48	F	60mm bushing	577 66 01-01	M1	Bladeguard 1000
531 12 30-51	F	Plate for hub	577 66 02-01	M1	Centre section complete
531 12 30-55	C	Cover plate	577 66 03-01	M1	Gable section complete
531 12 30-57	F	Water connection	577 66 04-01	N1	Bladeguard 1200
531 12 30-63	"L1-2M1-2 N1,3"	Rail for bladeguard	577 66 05-01	N1	Centre section 1200 compl.
531 12 30-65	K	Holder	577 66 07-01	N1	Gable section right 1200 cpl
531 12 30-66	K	Cover	577 66 09-01	N1	Gable section left 1200 cpl
531 12 30-70	K	Handle	577 69 92-01	"L1-2M1-2 N1,3"	Rail Fixture
531 12 30-71	K	Excentric shaft	577 69 93-01	"L1-2M1-2 N1,3"	Rail Fixture
531 12 30-75	H	Track holder	577 71 08-01	"L1-2M1-2 N2-3"	Guide bar
531 12 30-76	H	Clamping plate	577 74 23-01	L2	Bladeguard flush 800
531 12 30-95	F	Water hose	577 74 24-01	M2	Bladeguard flush 1000
531 12 30-96	H	Coupling link	577 74 25-01	N3	Bladeguard flush 1200 compl.
531 12 30-97	H	Clamping washer	577 74 27-01	L2	Centre section 800 flush cpl.
531 12 31-69	N1,3	Clamp	577 74 28-01	L2	Gable section flush Left cpl.
531 12 32-12	A	Outer tube	577 74 29-01	L2	Gable section flush Right cpl.
531 12 32-14	A	Mounting plate	577 74 30-01	M2	Gable section flush Left cpl.
531 12 32-27	C	Input shaft	577 74 32-01	M2	Gable section flush Right cpl.
531 12 32-34	C	Sun gear 166	577 74 33-01	N3	Centre sect. 1200 flush cpl.
531 12 32-36	C	Output sun gear 166	577 74 34-01	N3	Gable section flush Left cpl.
531 12 32-65	E	Input shaft			
531 12 32-70	E	Back cover			
541 40 49-09	"L1-2M1-2 N1,3"	Handle			
573 96 27-01	A	Spacer			
574 26 34-01	A	Spacing sleeve			

No.	Pos.	Description	No.	Pos.	Description
577 74 40-01	L2	End Cover	580 65 71-01	A	Motor ASSY
577 74 41-01	L2	End Cover	580 67 76-01	K	Guide wheel fixed
577 74 42-01	M2	End Cover	580 67 76-02	K	Guide wheel adjustable
577 74 43-01	M2	End Cover	580 67 77-01	K	Blade guard guide
577 74 44-01	N3	End cover	580 67 79-01	E	Blade shaft ASSY
577 74 45-01	N3	End cover	580 68 12-01	L1	Centre section 800
577 74 48-01	L2M2N3	Holder	580 68 12-02	M1M2	Centre section 1000
577 74 50-01	L2M2N3	U-list centre	580 68 12-03	N1	Centre section 1200
577 74 51-03	L2	U-list gable left 800	580 68 13-01	L1	Gable section 800
577 74 51-04	M2	U-list gable left 1000	580 68 13-02	M1	Gable section 1000
577 74 51-05	N3	U-list gable left 1200	580 68 13-03	N1	Gable section right 1200
577 74 52-03	L2	U-list gable right 800	580 68 13-04	N1	Gable section left 1200
577 74 52-04	M2	U-list gable right 1000	580 68 18-01	L2M2N3	Knob
577 74 52-05	N3	U-list gable right 1200	580 68 65-01	A	Saw handle WS 440 HF
577 88 62-01	A	Spacer	580 68 76-01	N1,3	Bracket
577 90 30-01	M2	Centre section 1000 flush cpl.	580 68 76-02	N1,3	Angle bracket
578 11 32-01	A	Housing	580 90 22-01	N1,3	Bar
578 37 31-01	C	Motor housing	580 95 79-01	L1M3N2	Gasket
578 37 32-01	B	Electronic box	580 96 45-01	L1M1N1	V-ring
578 37 34-01	B	Motor interface board WS440	580 96 46-01	L1M1N1	Plug
578 37 35-01	B	Cable cover	580 97 65-01	N1,3	Hook
578 37 36-01	B	Sealing plate	581 00 61-01	N1,3	Support bar assy
578 84 82-01	G	Plate	581 08 40-01	D	Ball
578 84 83-01	G	Holder	581 28 51-01	"L1-2M1-2 N2-3"	Rivet
578 84 84-01	G	Holder	581 78 37-01	C	Gear box depth feed ASSY
578 84 85-01	G	Block	581 78 38-01	C	Gear box track feed ASSY
578 98 77-01	"L1-2M1-2 N1-3"	Rivet	583 85 63-01	A	Type plate
579 16 47-01	B	Sealing plug 3-pole	720 12 71-50	G	Cylindrical pin 4x18
579 16 47-02	B	Sealing plug 4-pole	720 13 08-50	G	Cylindrical pin 5x16
579 16 48-01	A	Contact pin	720 13 51-50	E	Cylindrical pin 6x16
579 25 51-01	B	Screw MC6S 4x16	720 13 52-51	H	Cylindrical pin 6x18
579 43 67-01	"L1-2M1-2 N1,3"	Guide	720 13 53-50	J	Cylindrical pin 6x20
579 52 07-01	N1,3	Hook	720 13 65-51	J	Cylindrical pin 6x50
579 53 17-01	L1M1N1	Cone	723 51 93-51	C	Screw MFS 2,5x8
579 54 85-01	BC	Screw MC6S 3x6	723 53 66-51	F	Screw MFS 6x12
579 56 58-01	"L1-2M1-2 N1,3"	Screw MF6S 6x16 Bluepatch	723 53 66-51	F	Screw MFS 6x12
579 56 59-01	"L1-2M1-2 N1,3"	Screw MC6S 6x10 Bluepatch	725 22 87-71	B	Screw M6S 4x8
579 56 60-01	"L1-2M1-2 N2-3"	Screw MK6S 6x10 Bluepatch	725 25 43-51	H	Screw M6S 12x55
579 56 61-01	"L1-2M1-2 N1,3"	Screw MK6S 8x12 Bluepatch	725 25 44-91	E	Screw M6S 12x60
579 56 62-01	N1,3	Screw	725 25 56-51	J	Screw M6S 12x120
580 26 20-01	L1M1N1	Screw	725 52 89-01	E	Screw MC6S 4x10
580 26 21-01	L1M1N1	Nut	725 53 27-01	A	Screw MC6S 5x12
580 26 22-01	L1M1N1	Hook	725 53 29-01	E	Screw MC6S M5x16
580 32 33-01	"L1-2M1-2 N1,3"	Guide	725 53 31-01	C	Screw MC6S 5x20
580 32 73-01	L1M1N1	Screw MF6S 4x10 Bluepatch	725 53 33-01	A	Screw MC6S 5x25
580 32 74-01	L1M1N1	Pin CPK 2x10 DIN6325	725 53 41-01	K	Screw MC6S 5x50
580 39 62-01	G	Locking pin	725 53 62-01	K	Screw MC6S 6x8
580 40 53-01	B	Cover WS 440 HF	725 53 64-01	H	Screw MC6S M6x10
580 41 24-01	D	O-ring 71x4,5	725 53 68-01	GK	Screw MC6S 6x16
580 41 59-01	D	Bearing	725 53 70-01	G	Screw MC6S 6x20
580 42 49-02	D	Nut incl. O-ring	725 54 51-01	A	Screw MC6S 8x20
580 42 94-01	B	Contact pin	725 54 53-01	AG	Screw MC6S 8x25
580 43 28-01	G	Bearing	725 54 64-01	E	Screw MC6S 8x65
580 43 29-01	K	Bearing	725 54 93-01	G	Screw MC6S 10x25
580 44 81-01	G	Guide wheel concentric cpl.	725 62 87-01	E	Screw MF6S 4x8
580 44 82-01	G	Guide wheel excentric cpl.	725 63 27-51	AFK	Screw MF6S 5x12 10.9
580 44 83-01	G	Sleeve	725 63 28-51	N1,3	Screw MF6S 5x14 10.9
580 49 93-01	C	Shrinkage hose	725 63 30-51	K	Screw MF6S 5x16 10.9
580 62 50-01	C	Track feeding motor compl.	725 63 66-51	A	Screw MF6S 6x12 10.9
580 62 51-01	C	Depth feeding motor compl.	725 63 68-51	EK	Screw MF6S 6x16 10.9
580 63 78-01	E	Clutch gear assy	725 63 70-51	FKM1N2	Screw MF6S 6x20 10.9
580 64 54-01	L1M1N1	Knob assy	725 64 47-51	F	Screw MF6S 8x12 10.9 fzb
580 65 23-01	E	Pivoting arm complete	725 64 89-51	F	Screw MF6S 10x16 10.9
			728 72 89-05	D	Stop screw S6SS 4x10
			728 83 27-05	J	Stop screw SK6SS 5x12
			728 83 64-05	G	Stop screw SK6SS 6x10
			731 43 20-01	KN1,3	Nut M10 low
			732 25 14-01	K	Nut M5 Nylock
			732 25 16-01	M1N2	Nut

No.	Pos.	Description	No.	Pos.	Description
732 25 22-71	EJ	Nut M12 Nylock 10.9			
734 11 35-71	BG	Washer 4.3x8			
734 11 52-01	AM1N2	Washer 6.4x12			
734 11 63-01	EH	Washer 8.4x16			
735 31 28-10	G	Seeger circlip			
735 31 33-00	D	Seeger circlip SGA 35			
735 31 33-10	K	Seeger circlip SGH 35			
740 38 27-01	AFQ	Sealing ring 1/4			
740 42 02-00	B	O-ring 4,1x1,6			
740 42 04-00	B	O-ring 6,4x1,6			
740 42 07-00	F	O-ring 9,1x1,6			
740 43 07-00	H	O-ring 9,3x2,4			
740 43 11-00	BE	O-ring 13,3x2,4			
740 44 05-00	F	O-ring 22,2x3			

Go to Discount-Equipment.com to order your parts

A WS 440 HF

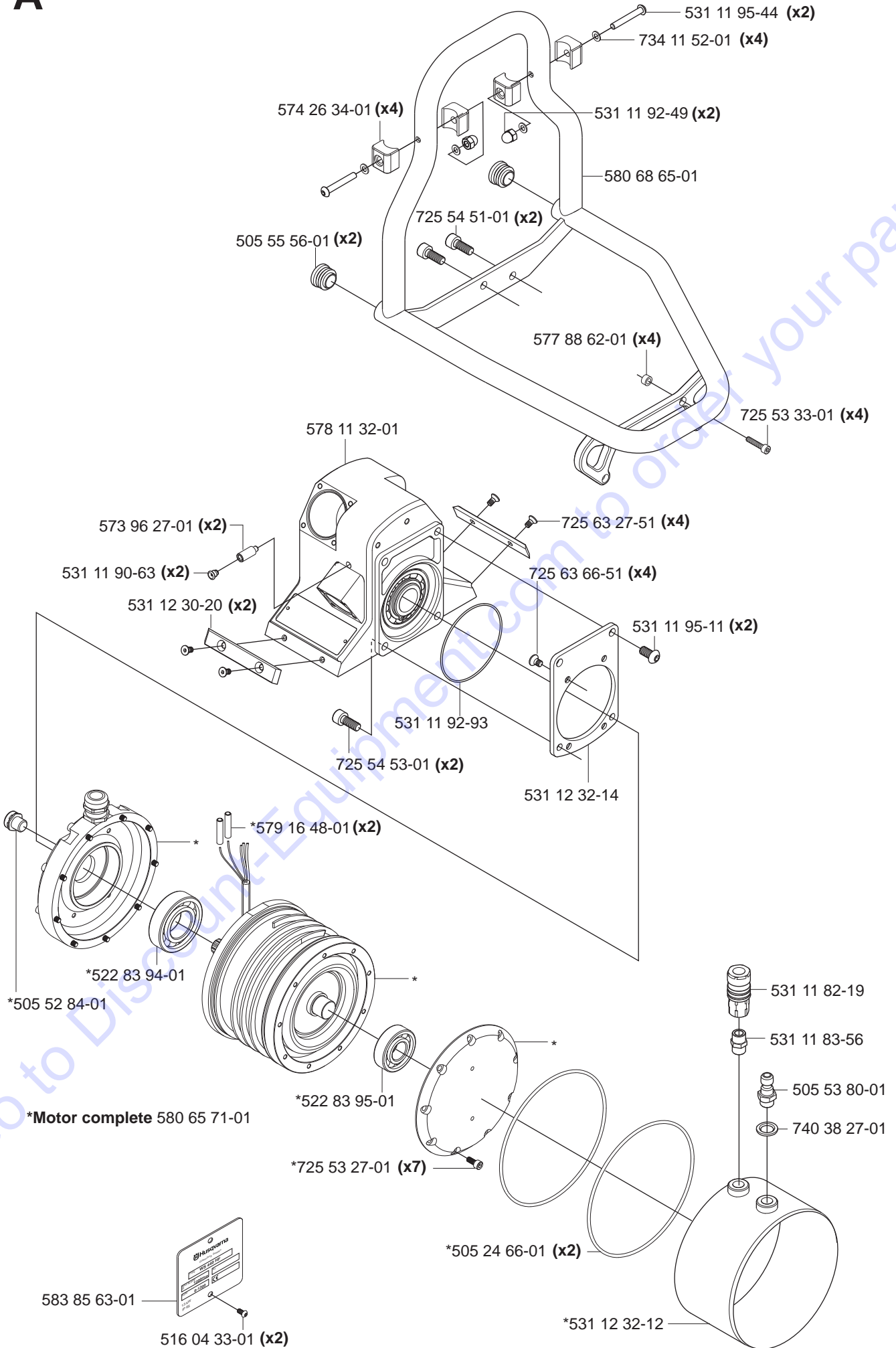

B WS 440 HF

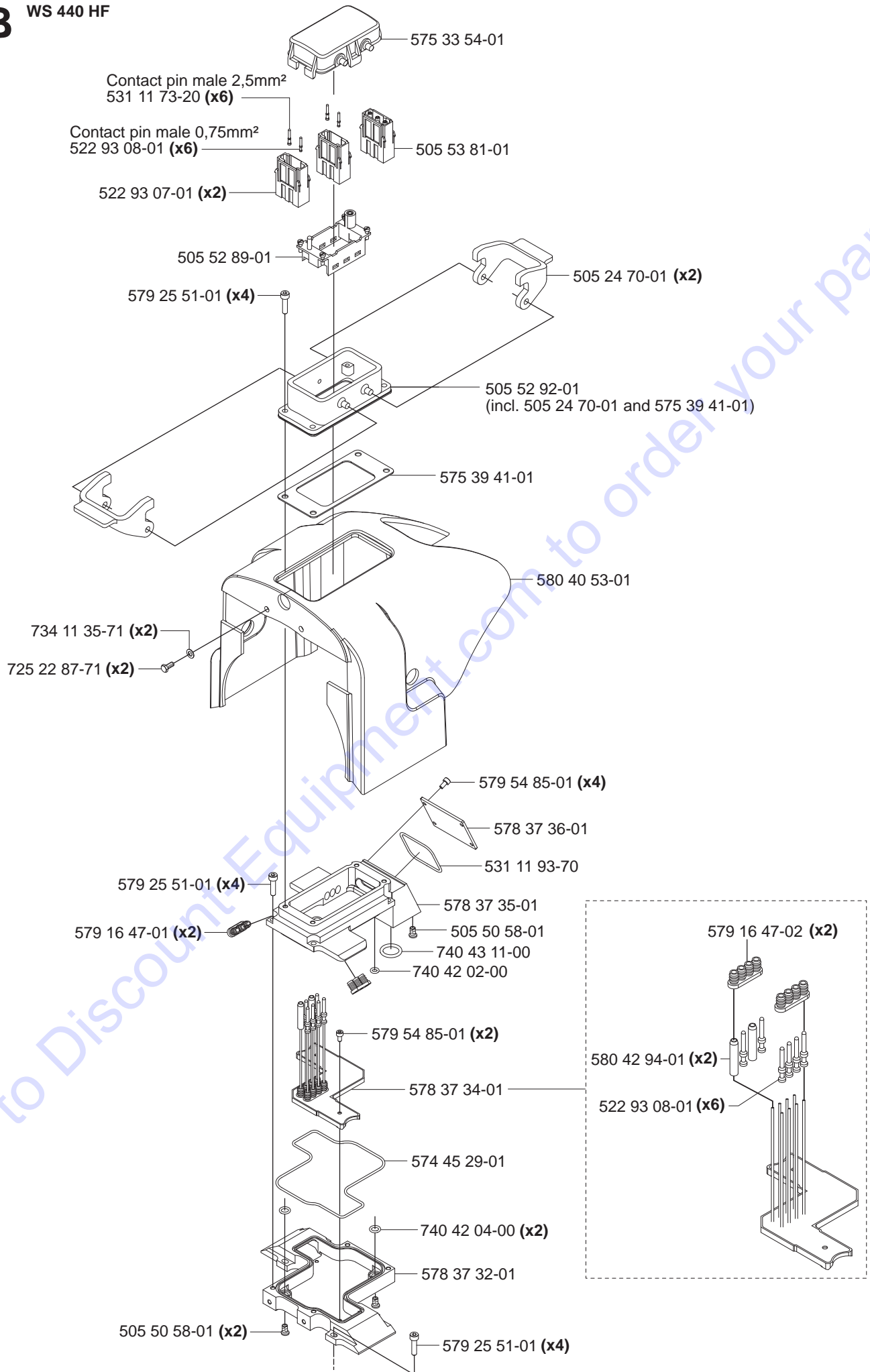

C WS 440 HF

Track feeding motor compl. 580 62 50-01

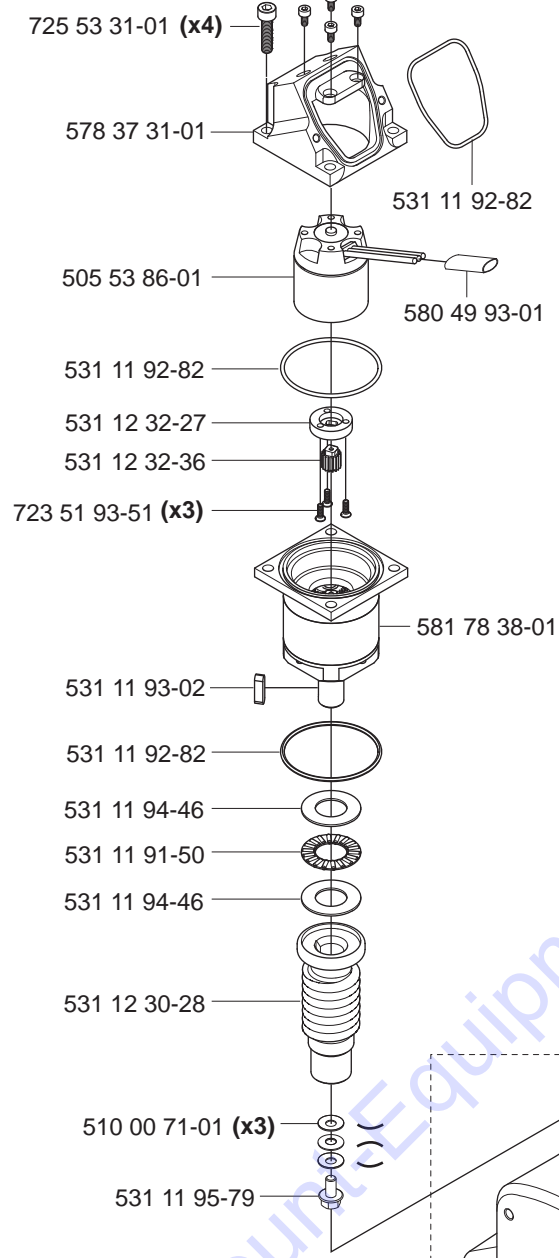

579 54 85-01 (x4) Arm feeding motor compl. 580 62 51-01

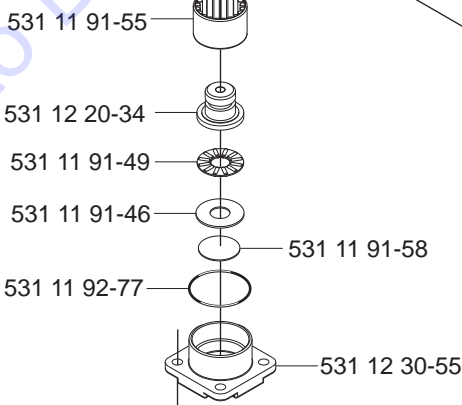
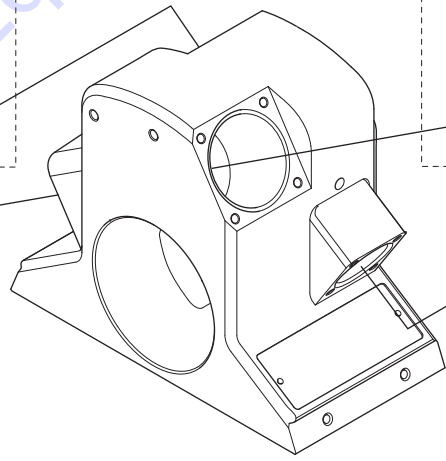
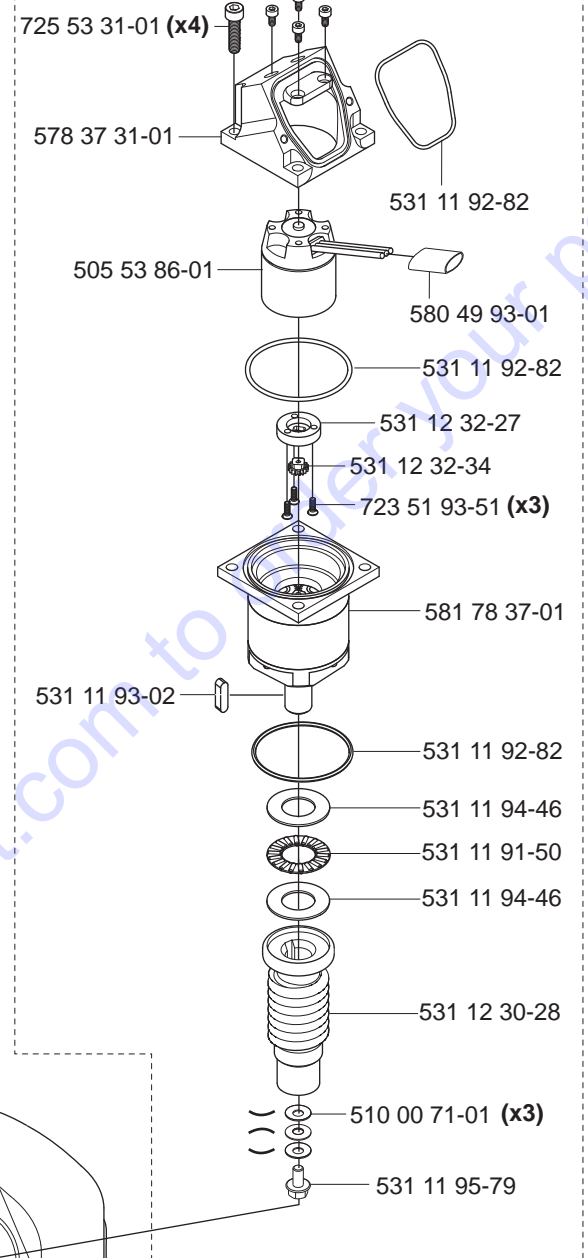

531 11 92-28 (x4)

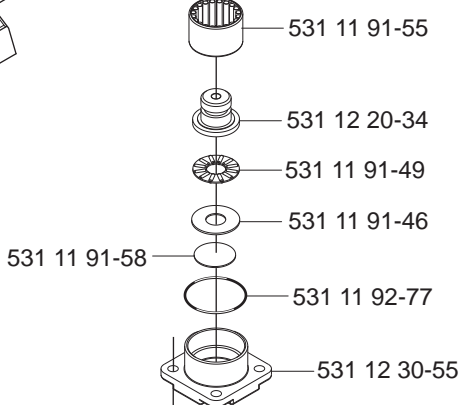

531 11 92-28 (x4)

D

WS 440 HF

Feed motor slip clutches

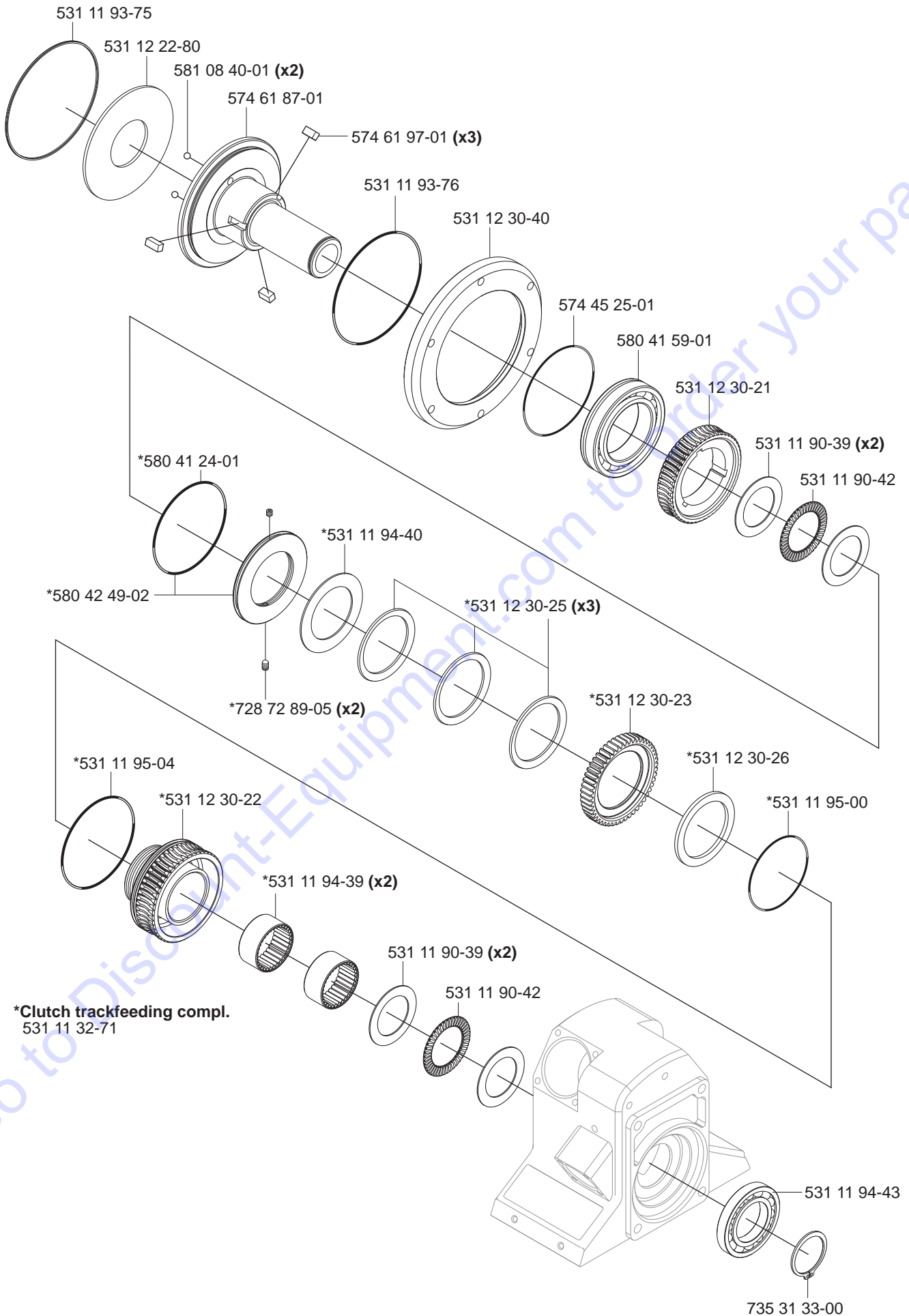

E WS 440 HF

Pivoting arm complete
505 11 65-01

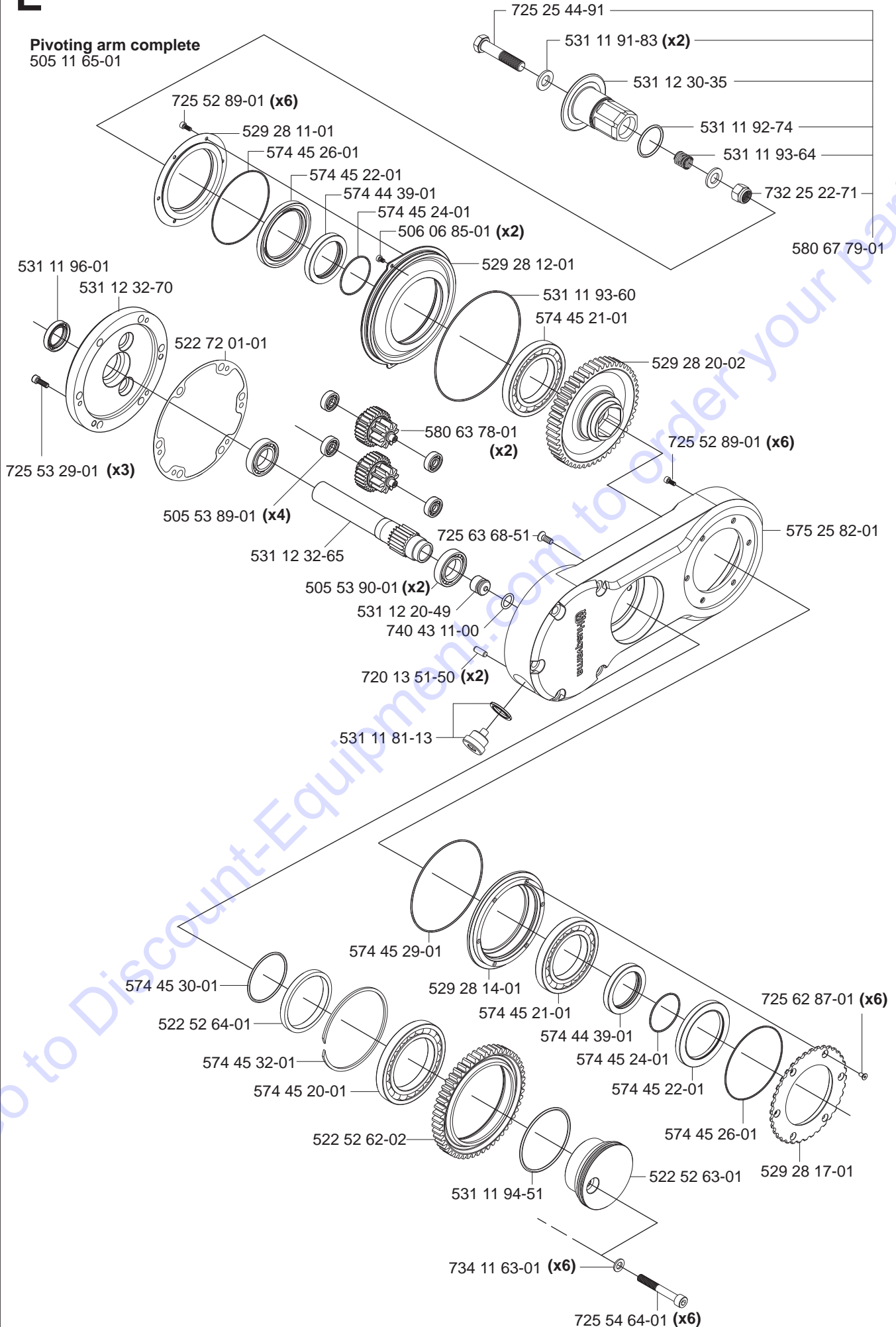

F WS 440 HF

- Flange 1" complete 574 82 95-01
- Flange 60mm complete 574 82 95-02
- Flange 130 complete 574 82 95-03

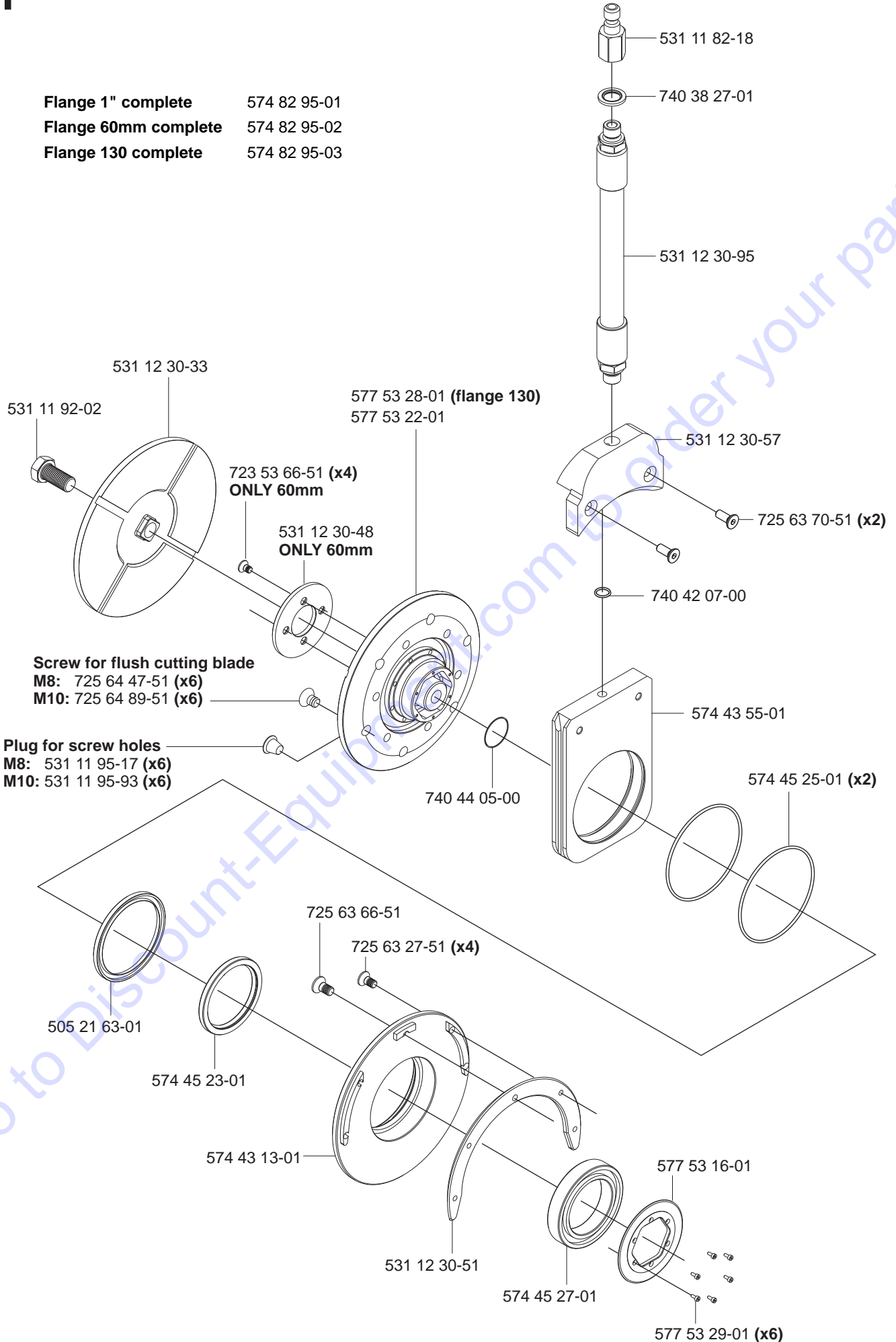

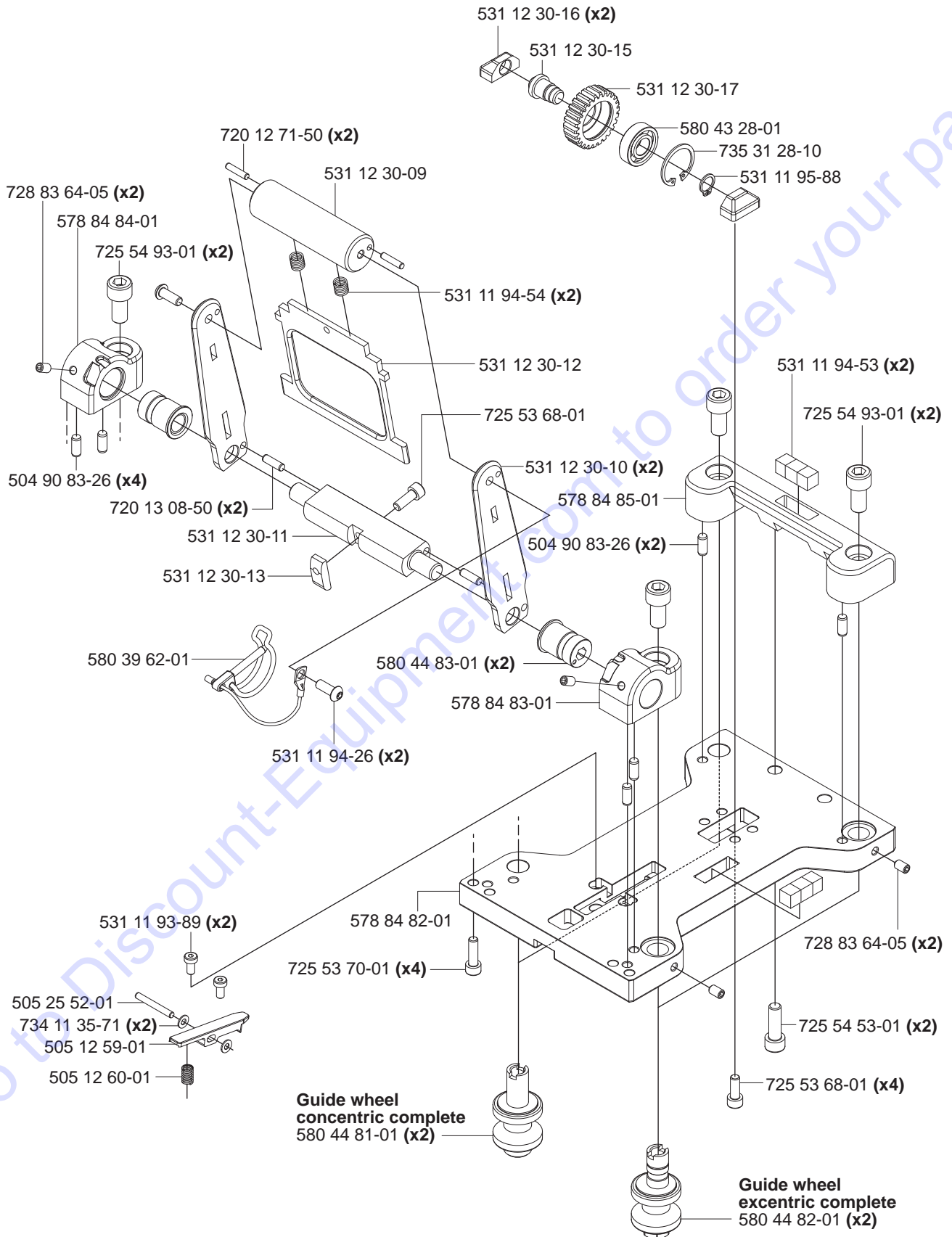
G**WS 440 HF Saw carriage 400 complete 505 22 69-03**

H WS 440 HF

Track 400 complete

1.2m 531 11 30-45

2.0m 531 11 30-46

2.2m 531 11 30-47

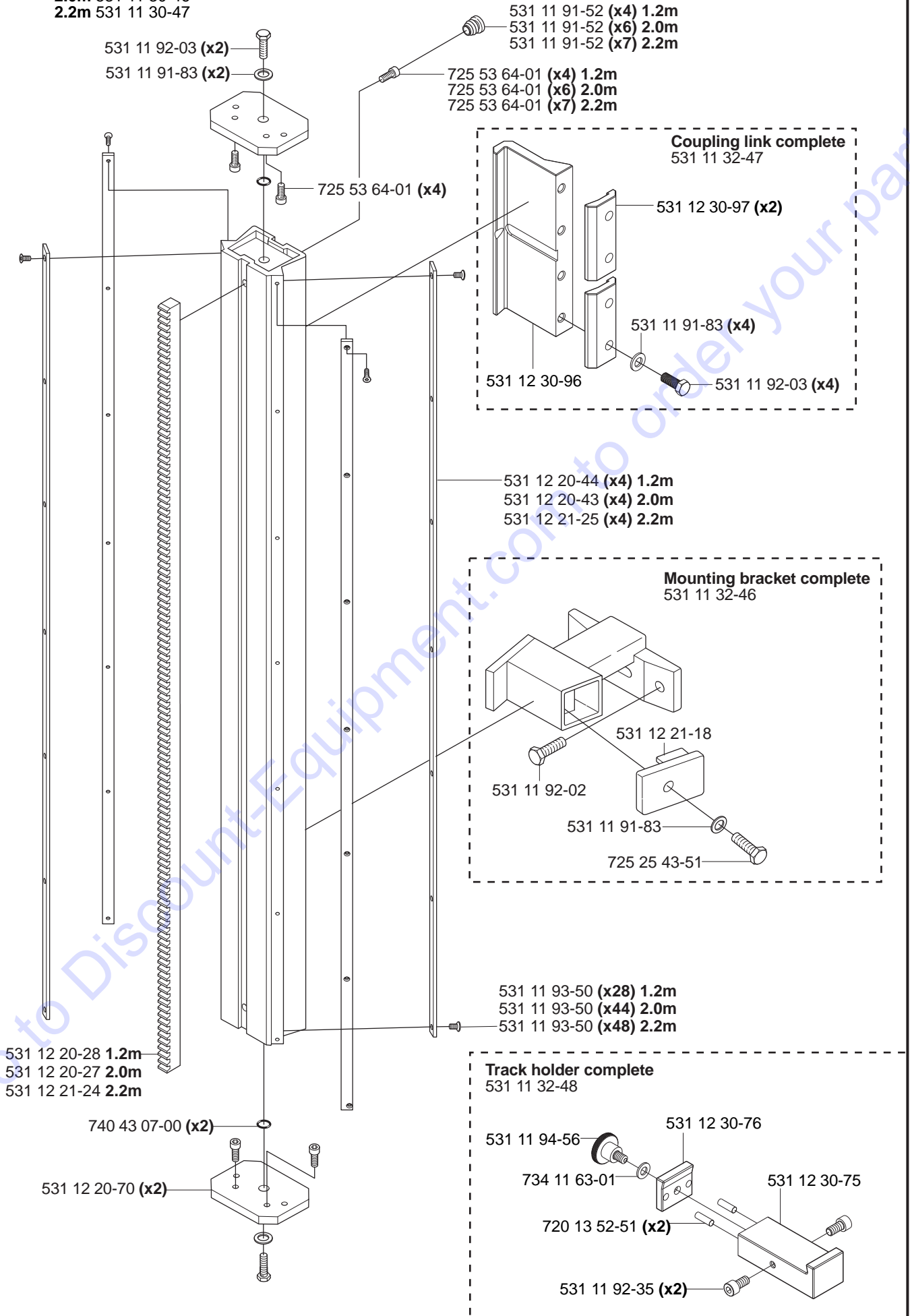

J**WS 440 HF**

Tillbehör
 Accessories
 Zubehöre
 Accessoires
 Accesorios

Mounting bracket Universal
 compl. 531 11 32-00

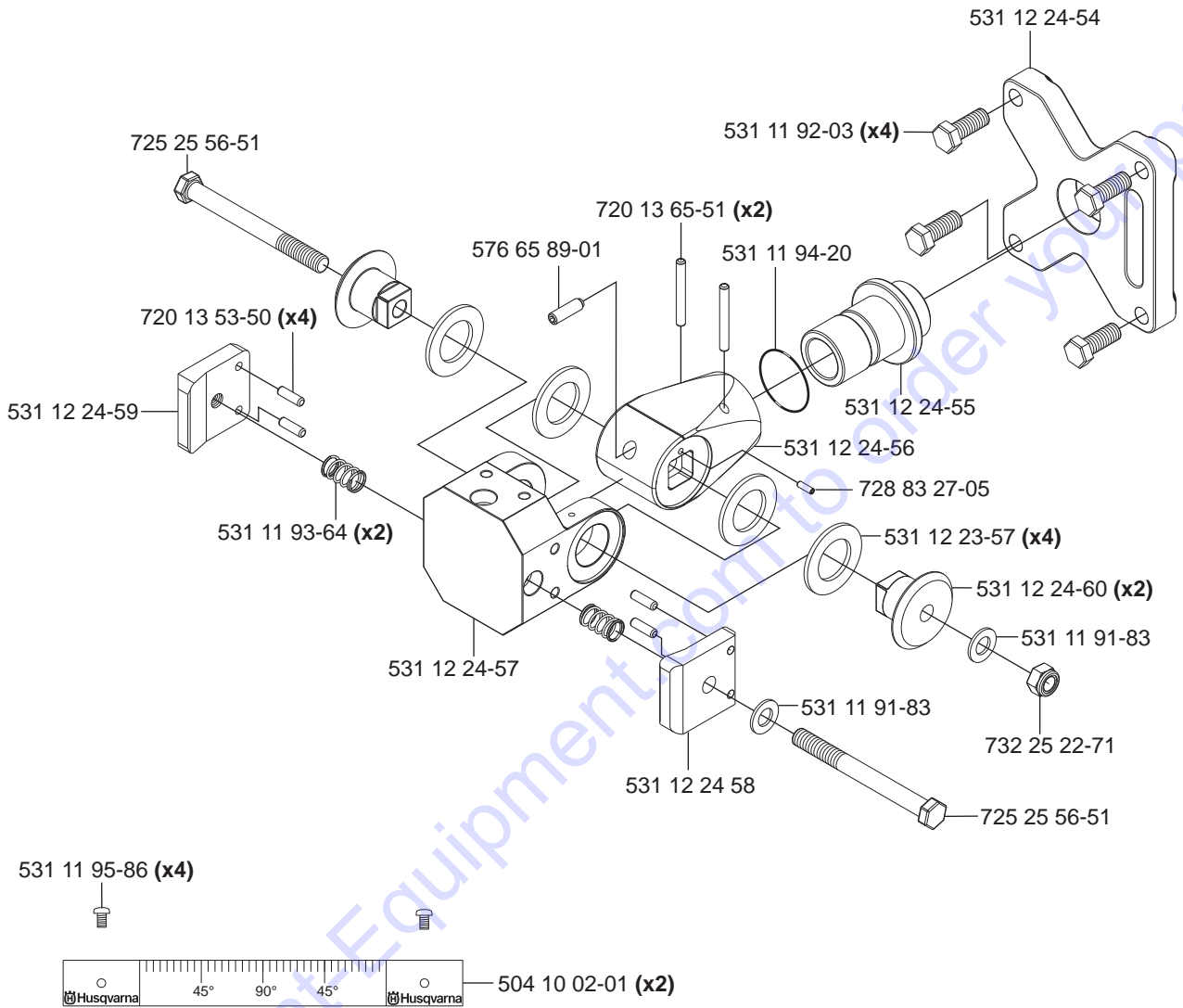

Measure rod complete 531 11 32-65

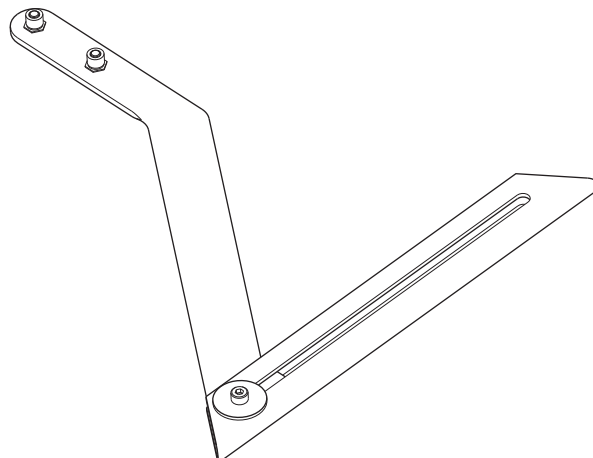

K

WS 440 HF

Blade guard guide Complete 580 67 77-01

580 67 76-01 (x4)

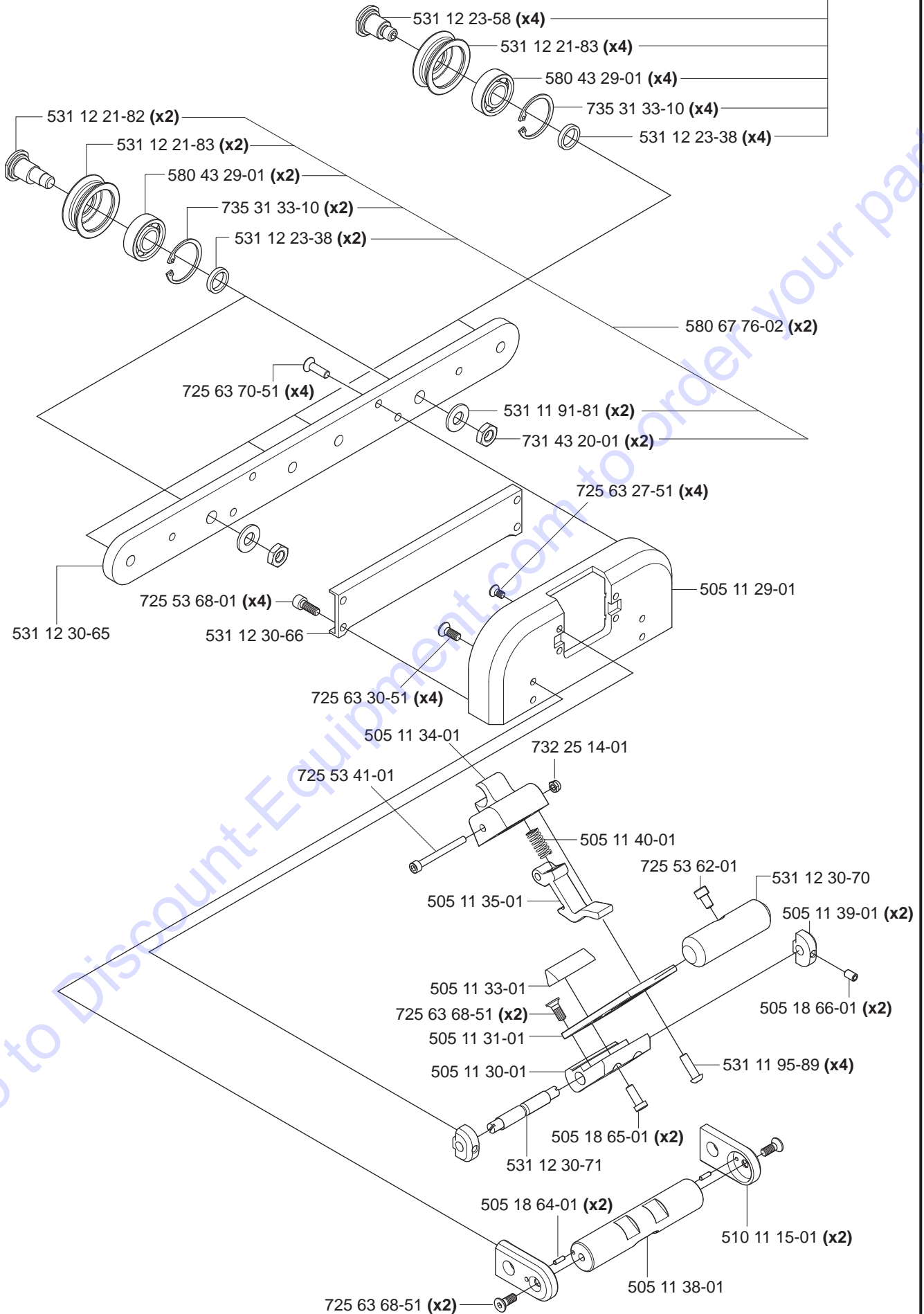

L1

WS 440 HF Blade guard 800mm Complete 577 65 97-01

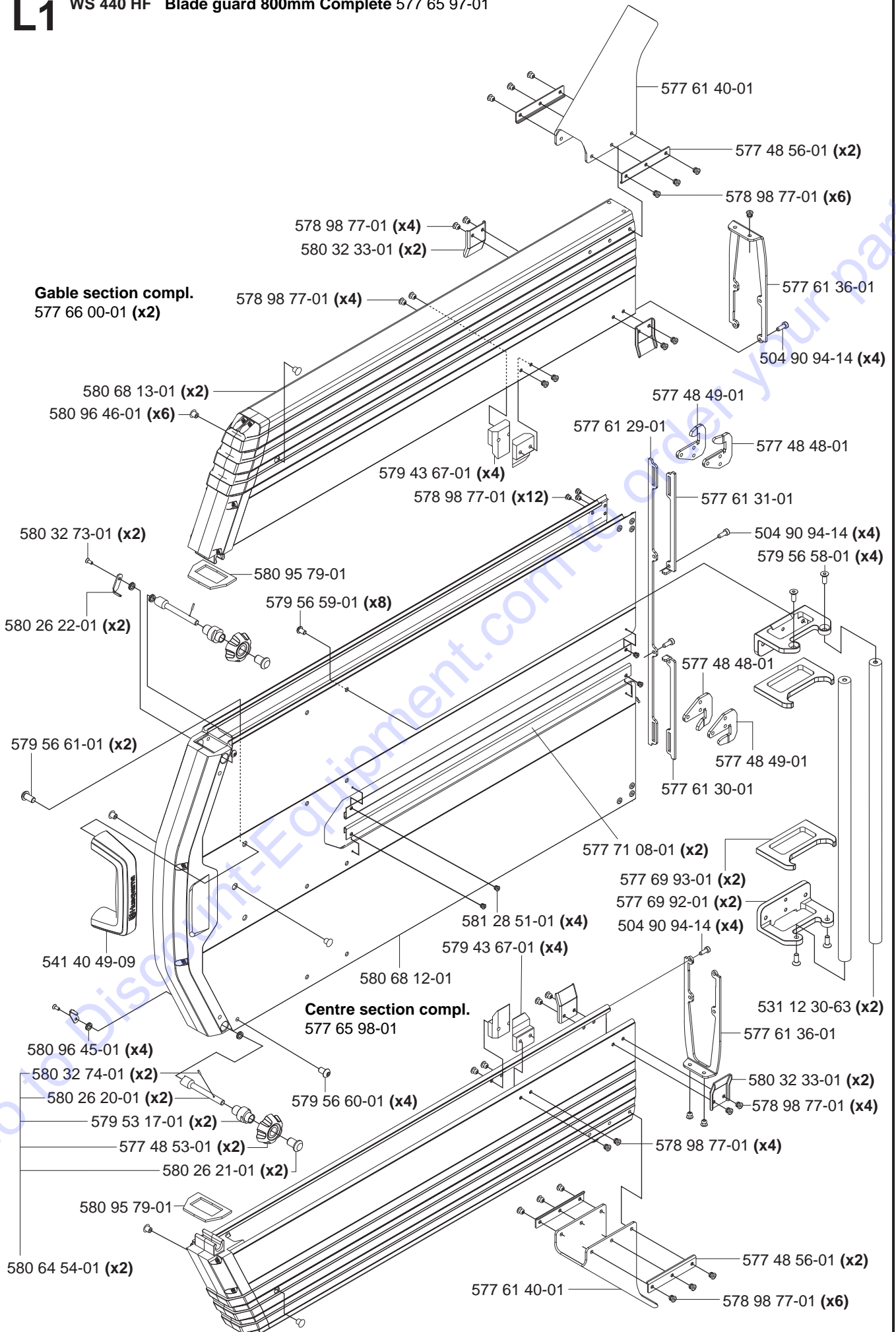

L2

WS 440 HF Flush blade guard 800mm complete 577 74 23-01

Gable section flush, RIGHT compl.
577 74 29-01

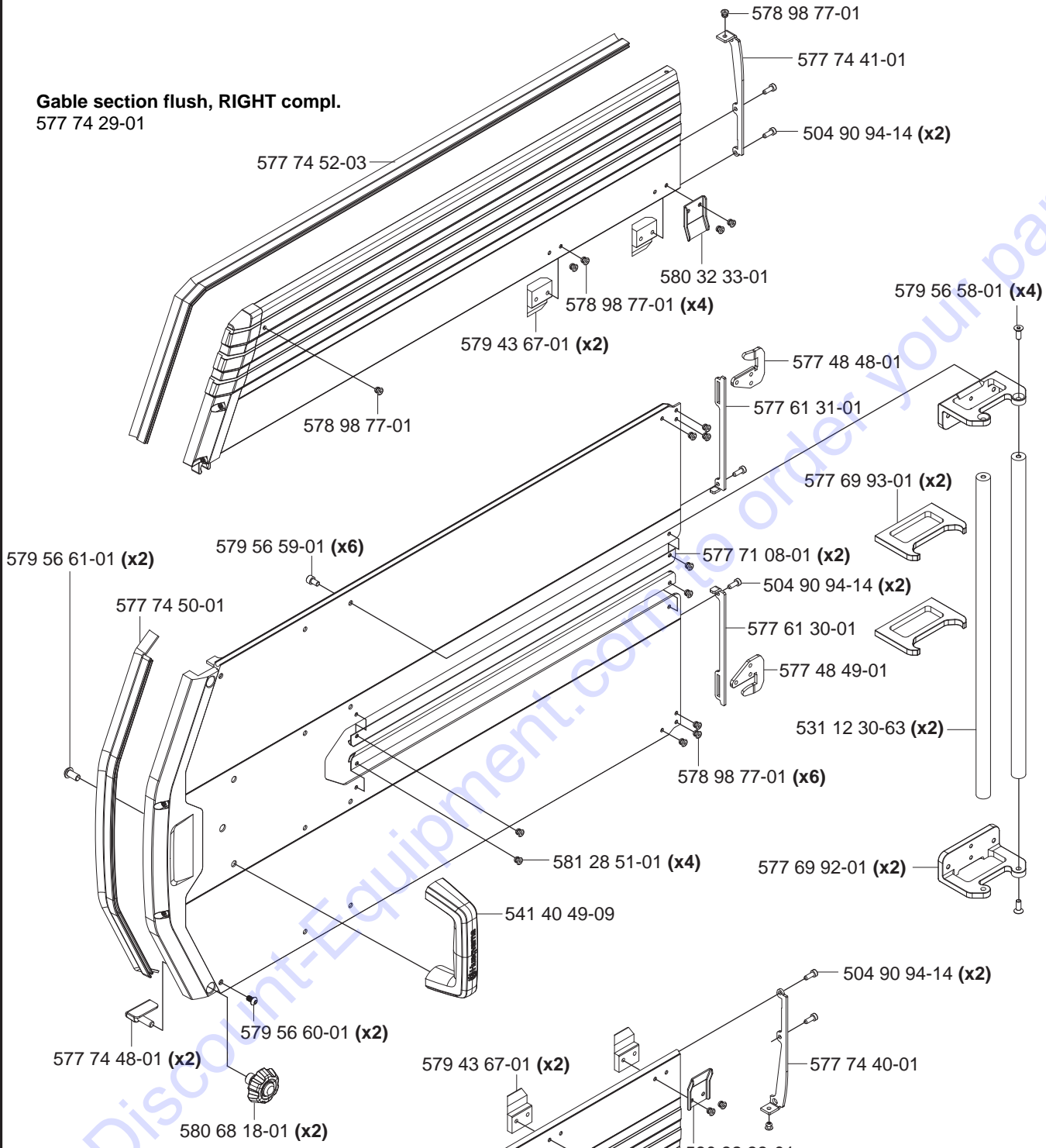

Centre section flush compl.
577 74 27-01

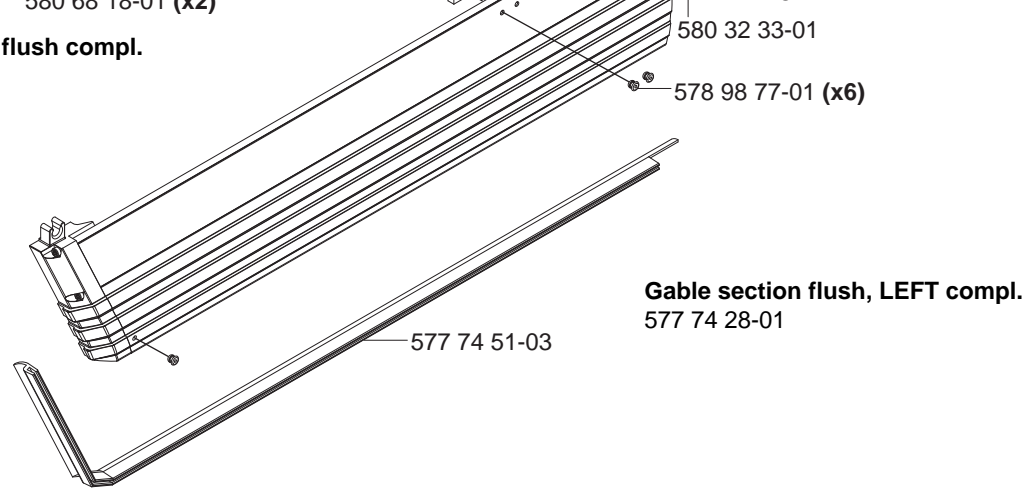

Gable section flush, LEFT compl.
577 74 28-01

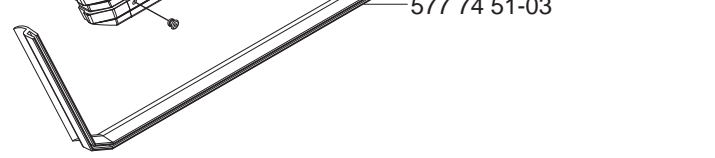

M1

WS 440 HF Blade guard 1000mm Complete 577 66 01-01

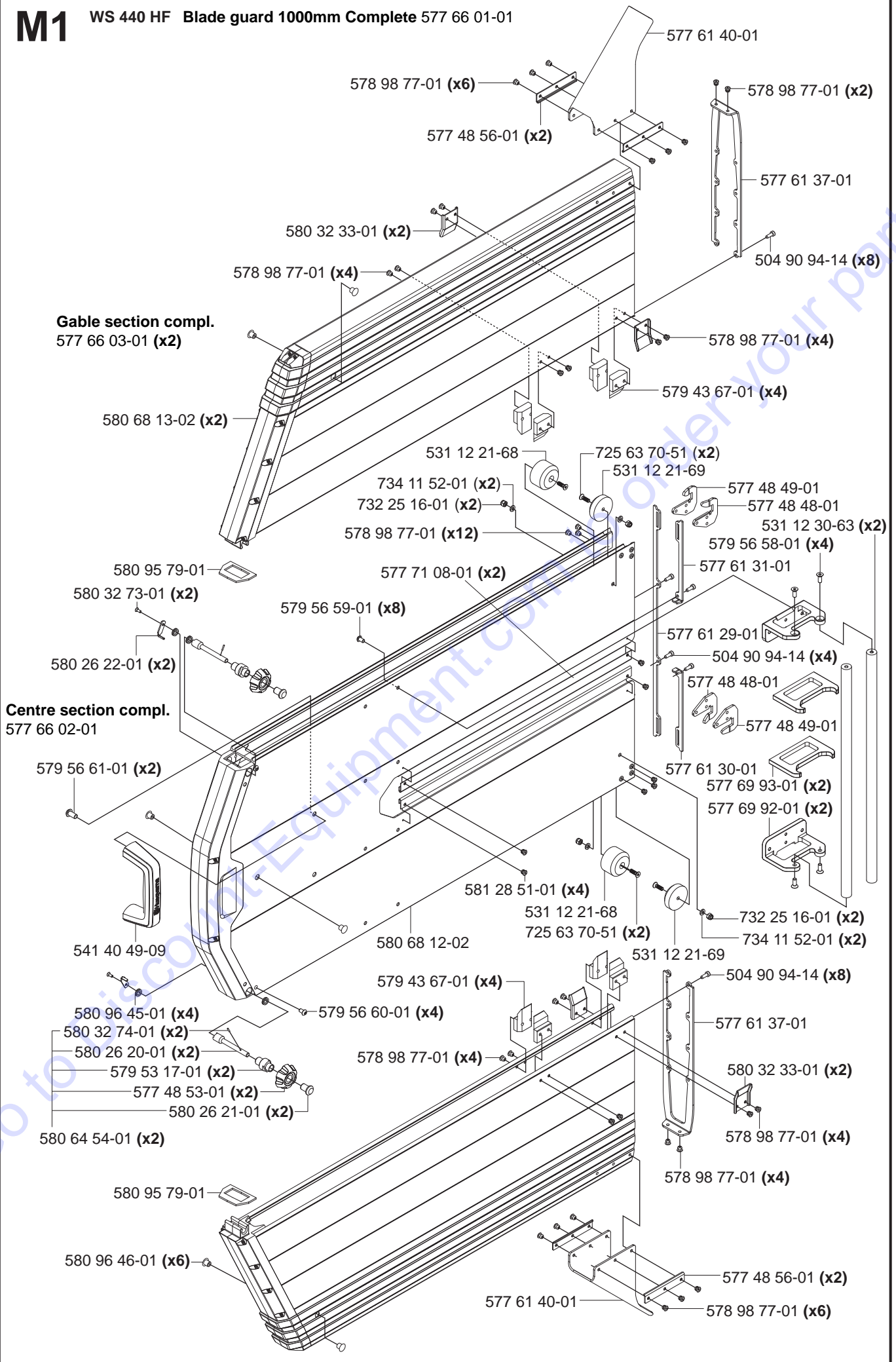

N1

WS 440 HF Blade guard 1200 mm 577 66 04-01

Gable section right compl.
577 66 07-01

579 56 58-01 (x4)

577 61 40-01

577 48 56-01 (x2)

578 98 77-01 (x6)

578 98 77-01 (x8)

580 32 33-01 (x2)

577 44 55-01 (x4)

580 96 46-01 (x6)

579 56 62-01 (x4)

725 63 28-51 (x8)

580 68 76-01 (x4)

531 11 90-80 (x2)

580 68 13-03

579 52 07-01 (x2)

Centre section compl.
577 66 05-01

579 56 59-01 (x4)

579 56 62-01 (x4)

580 32 73-01 (x2)

580 26 22-01 (x2)

579 56 58-01 (x4)

579 56 59-01 (x8)

579 56 58-01 (x4)

580 96 45-01 (x4)

579 56 59-01 (x4)

579 56 61-01 (x2)

577 69 93-01 (x2)

541 40 49-09

580 68 12-03

574 44 55-01 (x2)

531 12 30-63 (x2)

580 68 76-02 (x2)

580 32 74-01 (x2)

580 26 20-01 (x2)

579 53 17-01 (x2)

577 48 53-01 (x2)

580 26 21-01 (x2)

578 98 77-01 (x8)

580 32 33-01 (x2)

580 64 54-01

579 43 67-01 (x8)

579 56 59-01 (x4)

Gable section left compl.
577 66 09-01

531 11 95-24

580 97 65-01

580 90 22-01

731 43 20-01 (x2)

531 11 95-46

531 12 31-69

578 98 77-01 (x8)

577 61 40-01

577 69 92-01 (x4)

577 48 56-01 (x2)

578 98 77-01 (x6)

581 00 61-01

580 68 13-04

N2

WS 440 HF Blade guard centre section 1200 mm

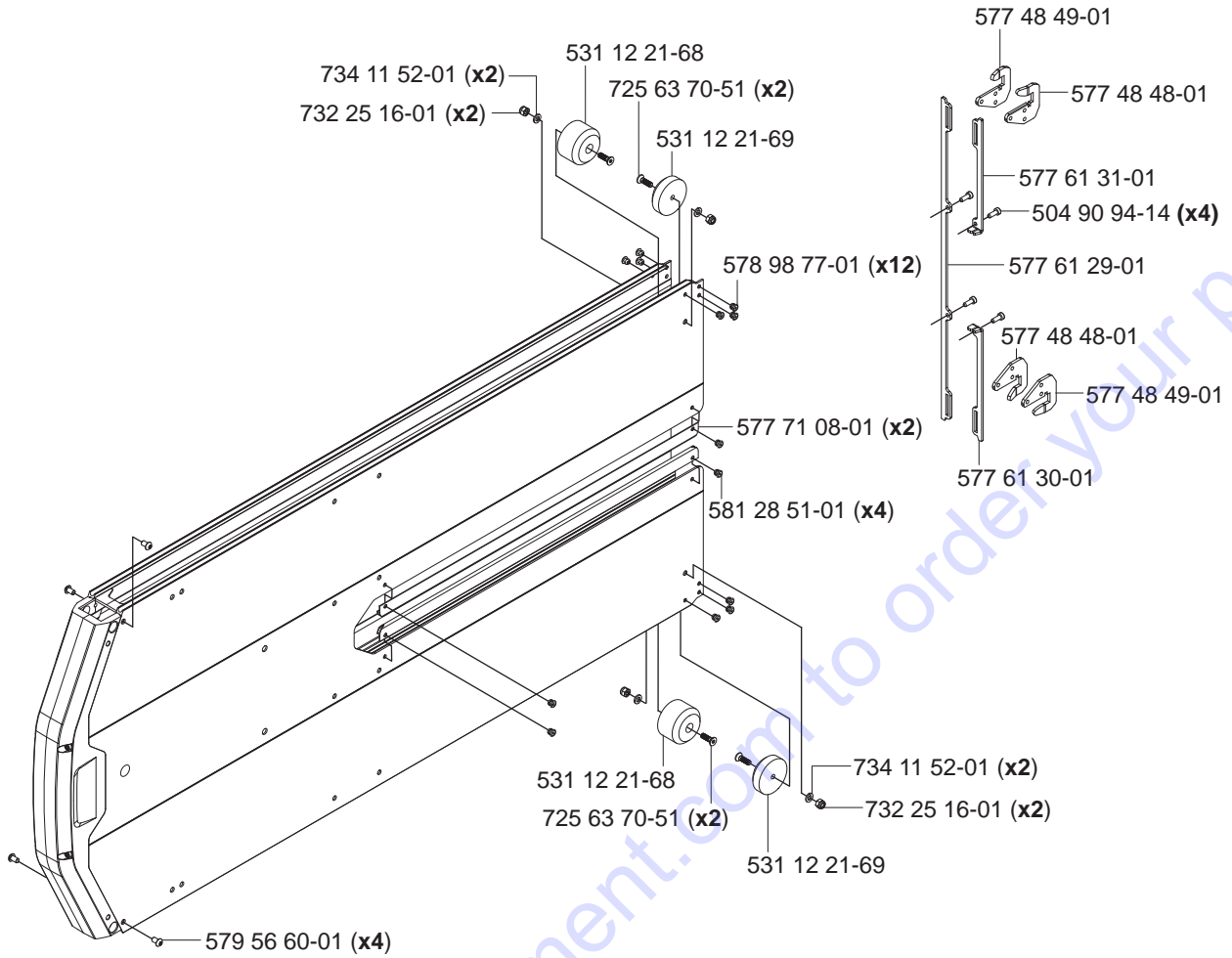

Blade guard gable section 1200 mm

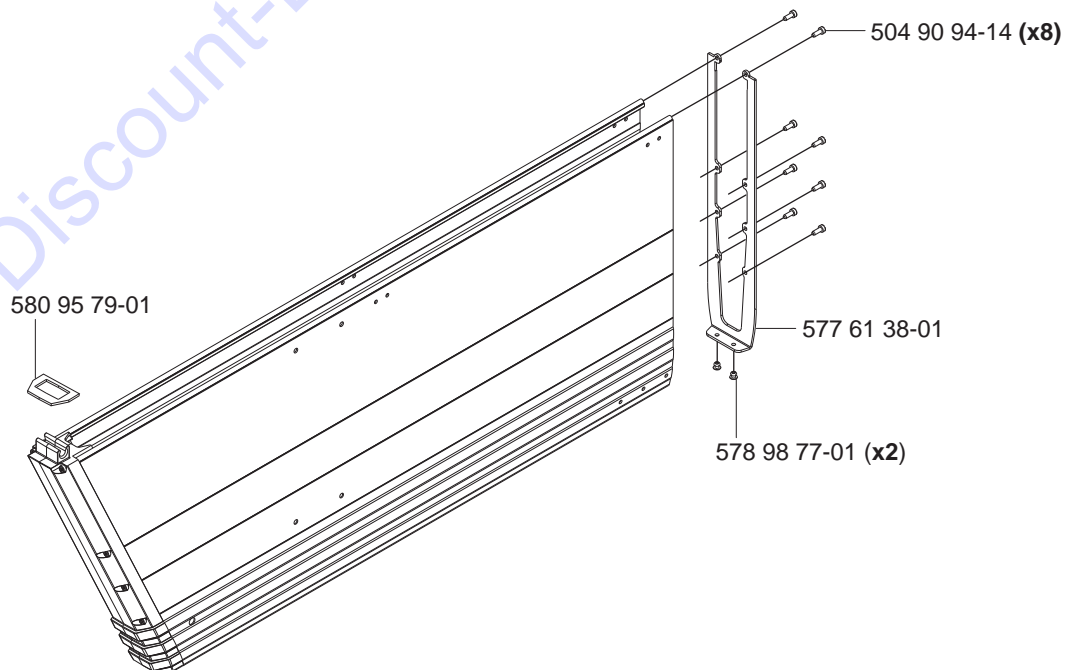

N3

WS 440 HF Flush blade guard 1200 mm 577 74 25-01

Gable section flush, RIGHT compl. 577 41 35-01

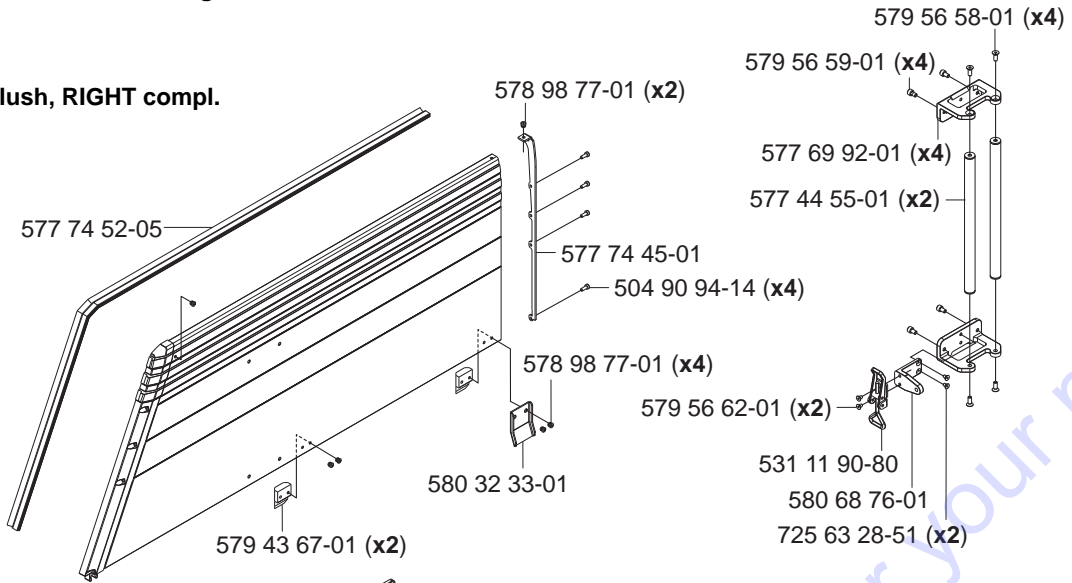

Centre section flush compl. 577 74 33-01

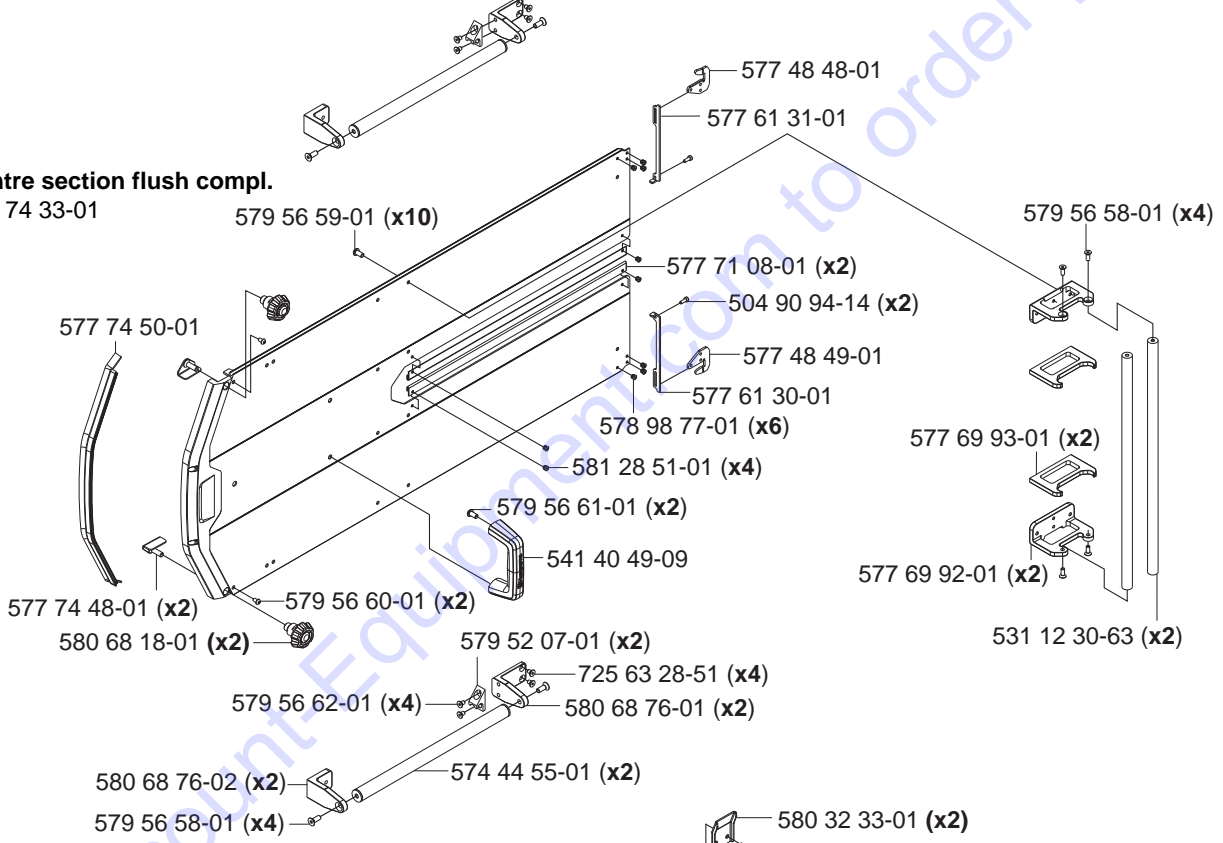

Gable section flush, LEFT compl. 577 74 34-01

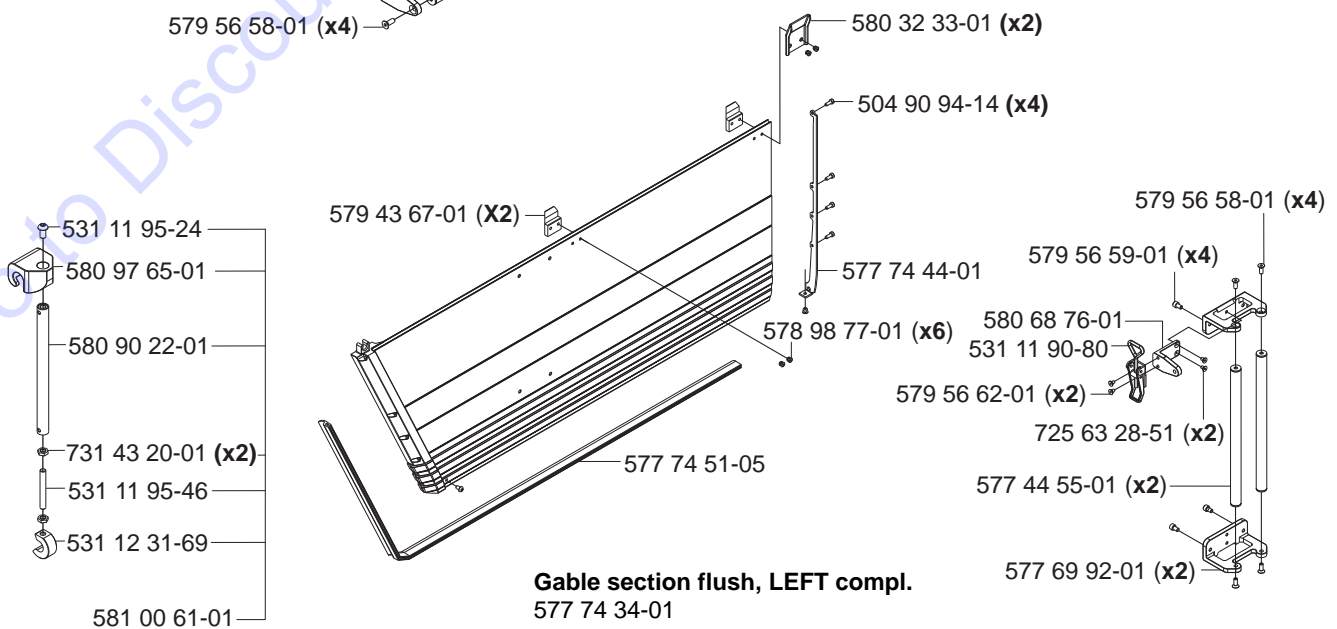

P

WS 440 HF

Toolkit compl 501 37 52-01

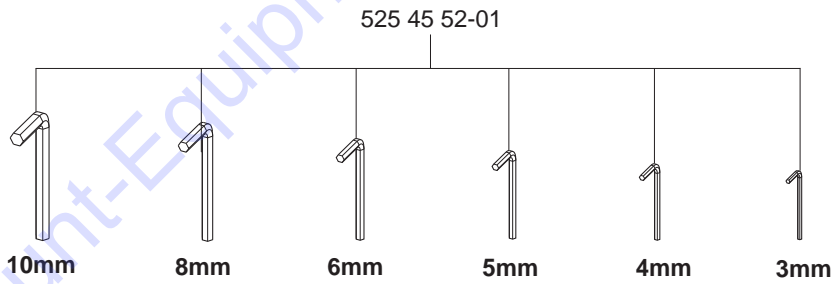
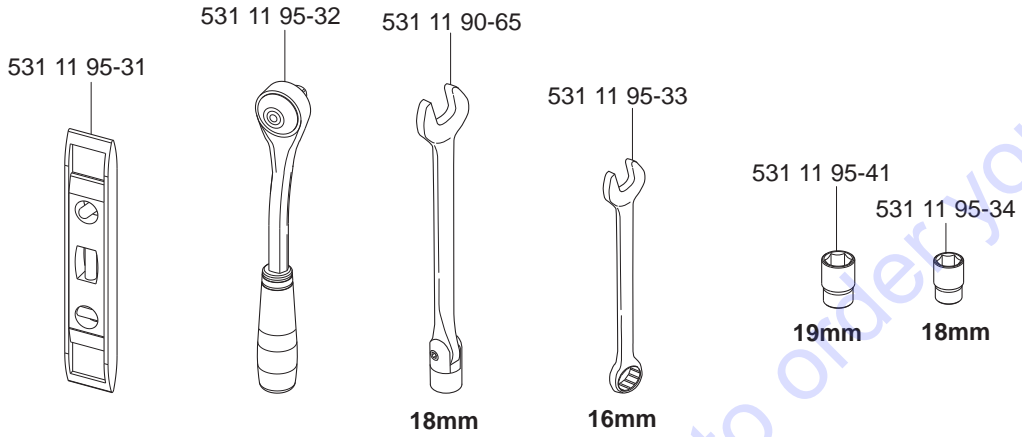

522 82 77-01



531 11 91-08



Q

WS 440 HF

Water hose 8m 505 11 53-01

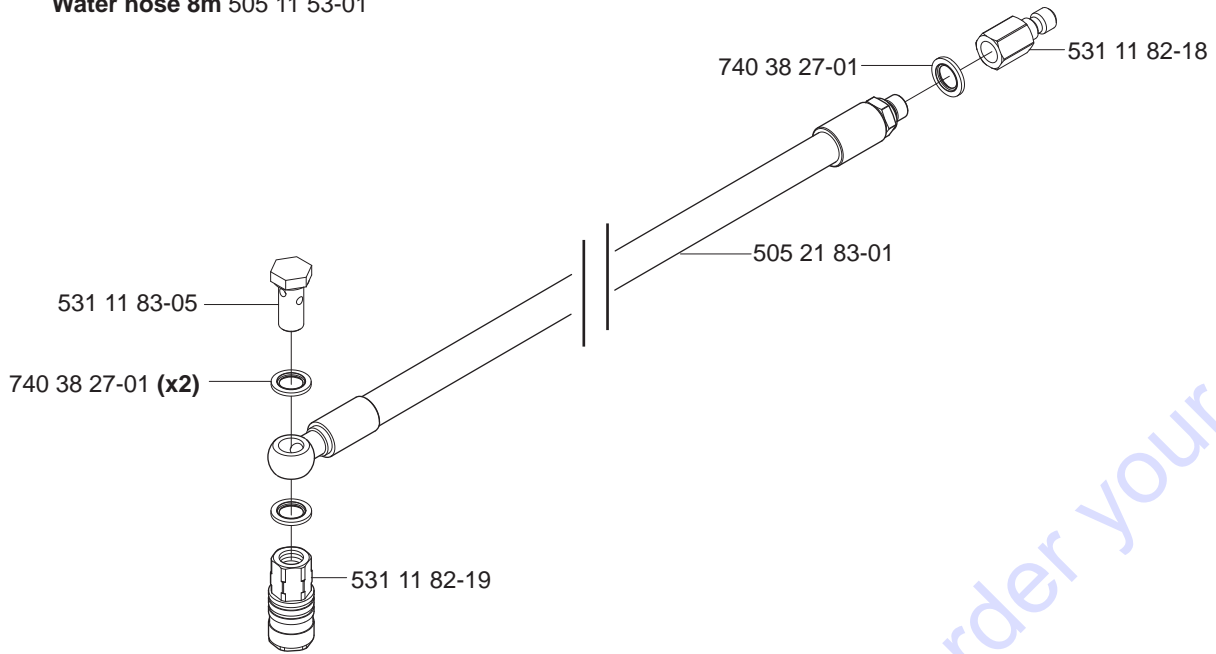

Water hose 1m 505 21 84-01

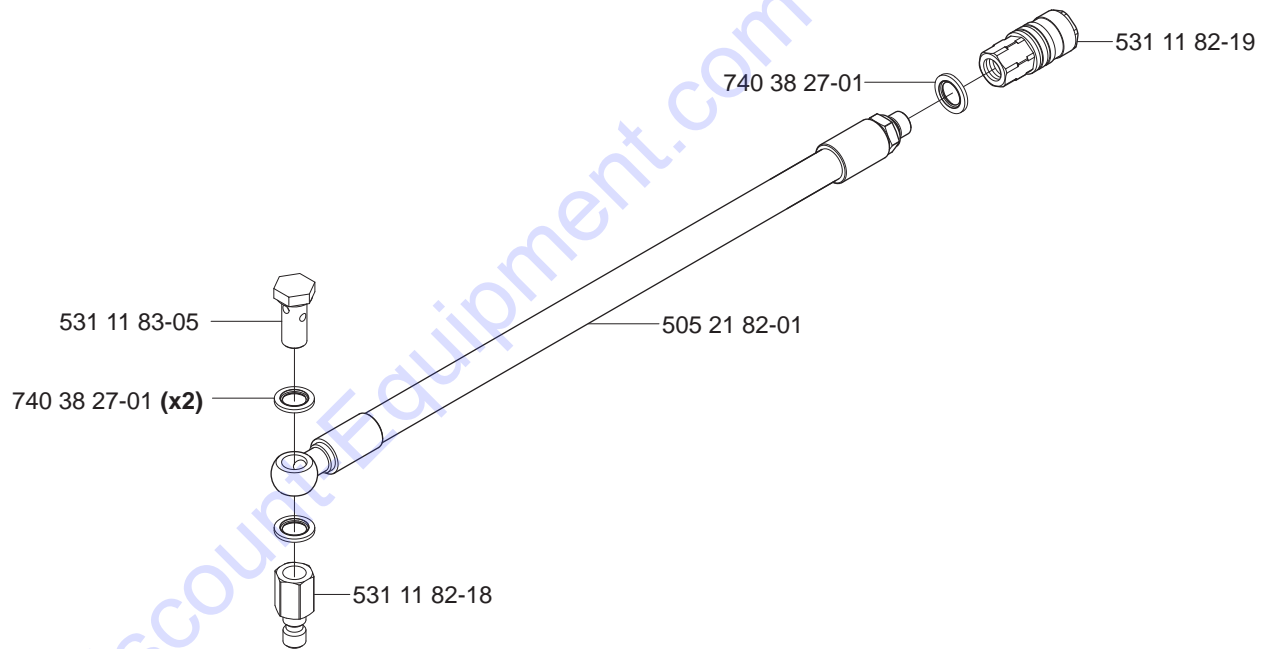

Cleaning brush complete 531 11 32-68

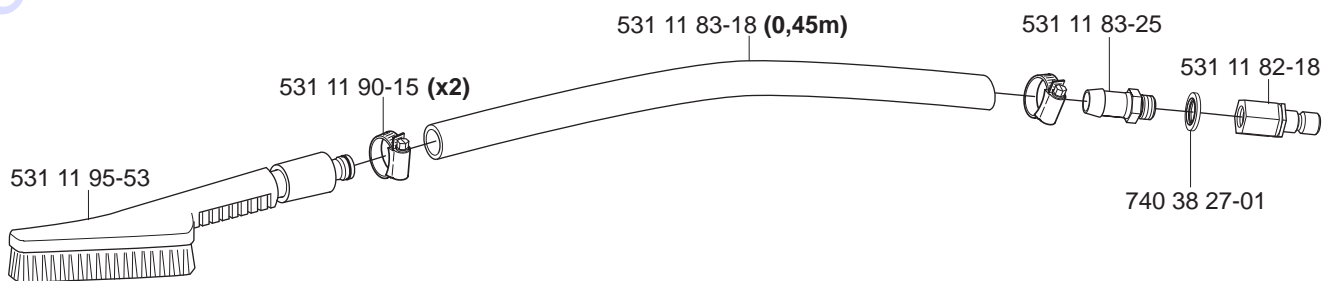

PARTS FINDER

**Search Website
by Part Number**



**Search Manual
Library For Parts
Manual & Lookup Part
Numbers – Purchase
or Request Quote**

Search Manuals

Enter your information to help us find the right parts manual for your machine.

* Brand:

* Model:

* Serial:

* Part Number:

SEARCH

**Can't Find Part or
Manual? Request Help
by Manufacturer,
Model & Description**

Parts Order Form

Please fill in the following information to help us find the right part for your machine.

Manufacturer:	<input type="text"/>
Model:	<input type="text"/>
Description:	<input type="text"/>
Part Number:	<input type="text"/>
Quantity:	<input type="text"/>
Notes:	<input type="text"/>

Discount-Equipment.com is your online resource for quality parts & equipment.

Florida: **561-964-4949** Outside Florida TOLL FREE: **877-690-3101**

Need parts?

Click on this link: <http://www.discount-equipment.com/category/5443-parts/> and choose one of the options to help get the right parts and equipment you are looking for. Please have the machine model and serial number available in order to help us get you the correct parts. If you don't find the part on the website or on one of the online manuals, please fill out the request form and one of our experienced staff members will get back to you with a quote for the right part that your machine needs.

We sell worldwide for the brands: Genie, Terex, JLG, MultiQuip, Mikasa, Essick, Whiteman, Mayco, Toro Stone, Diamond Products, Generac Magnum, Airman, Haulotte, Barreto, Power Blanket, Nifty Lift, Atlas Copco, Chicago Pneumatic, Allmand, Miller Curber, Skyjack, Lull, Skytrak, Tsurumi, Husquvarna Target, Stow, Wacker, Sakai, Mi-T-M, Sullair, Basic, Dynapac, MBW, Weber, Bartell, Bennar Newman, Haulotte, Ditch Runner, Menegotti, Morrison, Contec, Buddy, Crown, Edco, Wyco, Bomag, Laymor, EZ Trench, Bil-Jax, F.S. Curtis, Gehl Pavers, Heli, Honda, ICS/PowerGrit, IHI, Partner, Imer, Clipper, MMD, Koshin, Rice, CH&E, General Equipment, Amida, Coleman, NAC, Gradall, Square Shooter, Kent, Stanley, Tamco, Toku, Hatz, Kohler, Robin, Wisconsin, Northrock, Oztec, Toker TK, Rol-Air, APT, Wylie, Ingersoll Rand / Doosan, Innovatech, Con X, Ammann, Mecalac, Makinex, Smith Surface Prep, Small Line, Wanco, Yanmar