

WS 440 HF

Reservdelar

Spare parts

Ersatzteile

Pieces de rechange

Piezas de repuesto

Ricambi

Peças sobresselente



# PARTS FINDER

**Search Website  
by Part Number**



**Search Manual  
Library For Parts  
Manual & Lookup Part  
Numbers – Purchase  
or Request Quote**

**Search Manuals**

Enter your information to help us find the right parts manual for your machine.

\* Brand:

\* Model:

\* Serial:

\* Part Number:

SEARCH

**Can't Find Part or  
Manual? Request Help  
by Manufacturer,  
Model & Description**

**Parts Order Form**

Please fill in the following information to help us find the right part for your machine.

Manufacturer:	<input type="text"/>
Model:	<input type="text"/>
Description:	<input type="text"/>
Part Number:	<input type="text"/>
Quantity:	<input type="text"/>
Notes:	<input type="text"/>

Discount-Equipment.com is your online resource for quality parts & equipment.

Florida: **561-964-4949** Outside Florida TOLL FREE: **877-690-3101**

**Need parts?**

Click on this link: <http://www.discount-equipment.com/category/5443-parts/> and choose one of the options to help get the right parts and equipment you are looking for. Please have the machine model and serial number available in order to help us get you the correct parts. If you don't find the part on the website or on one of the online manuals, please fill out the request form and one of our experienced staff members will get back to you with a quote for the right part that your machine needs.

We sell worldwide for the brands: Genie, Terex, JLG, MultiQuip, Mikasa, Essick, Whiteman, Mayco, Toro Stone, Diamond Products, Generac Magnum, Airman, Haulotte, Barreto, Power Blanket, Nifty Lift, Atlas Copco, Chicago Pneumatic, Allmand, Miller Curber, Skyjack, Lull, Skytrak, Tsurumi, Husquvarna Target, Stow, Wacker, Sakai, Mi-T-M, Sullair, Basic, Dynapac, MBW, Weber, Bartell, Bennar Newman, Haulotte, Ditch Runner, Menegotti, Morrison, Contec, Buddy, Crown, Edco, Wyco, Bomag, Laymor, EZ Trench, Bil-Jax, F.S. Curtis, Gehl Pavers, Heli, Honda, ICS/PowerGrit, IHI, Partner, Imer, Clipper, MMD, Koshin, Rice, CH&E, General Equipment, Amida, Coleman, NAC, Gradall, Square Shooter, Kent, Stanley, Tamco, Toku, Hatz, Kohler, Robin, Wisconsin, Northrock, Oztec, Toker TK, Rol-Air, APT, Wylie, Ingersoll Rand / Doosan, Innovatech, Con X, Ammann, Mecalac, Makinex, Smith Surface Prep, Small Line, Wanco, Yanmar

No.	Pos.	Description	No.	Pos.	Description
501 37 29-01	M	Flush guard sect.800 right cpl	505 50 58-01	B	Drain plug
501 37 30-01	M	Fluch guard sect.800 left cpl.	505 52 84-01	A	Ventilating valve
501 37 31-01	M	Flushguard sect.1000 right cpl	505 52 89-01	B	Frame
501 37 32-01	M	Flush guard sect.1000 left cpl	505 52 92-01	B	Contact housing
501 37 33-01	M	Flushguard sect.1240 Right cpl	505 53 80-01	A	Quick coupling
501 37 34-01	M	Flush guard sect.1240 left Cpl	505 53 81-01	B	Console 3-pin
501 37 52-01	P	Tool kit	505 53 84-01	B	Cover
504 00 50-01	M	Blade guard flush D800 Assy	505 53 86-01	C	Motor
504 00 52-01	M	Blade guard flush D1000 Assy	505 53 88-01	C	Motor cover
504 00 53-01	M	Blade guard flush D1240 Assy	505 53 89-01	E	Bearing 608-2RSL
504 10 02-01	J	Scale, angle	505 53 90-01	E	Bearing 61905-2RZ
504 10 29-01	P	Tool bag	505 53 92-01	B	Console 6-pin
505 09 94-01	E	Cover plate	505 53 93-01	B	Console 6-pin
505 11 29-01	K	Mount	505 55 56-01	A	Plastic plug
505 11 30-01	K	Excentric	506 06 85-01	E	Screw
505 11 31-01	K	Handle bracket	510 00 71-01	C	Cup spring
505 11 33-01	K	Beam	510 11 15-01	K	Handle holder
505 11 34-01	K	Snap locking	510 19 56-01	P	OIL transmission 150 0,3l.
505 11 35-01	K	Hook	516 04 33-01	A	Screw K6S 5x6
505 11 38-01	K	Handle	522 53 66-01	B	Screw K6S 6x8
505 11 39-01	K	Shaft seat	522 53 68-01	D	Plug
505 11 40-01	K	Spring	522 71 01-01	B	Grommet
505 11 40-01	K	Spring	522 72 01-01	E	Gasket
505 11 42-01	A	Spacing sleeve	522 73 40-01	L	Outer side 800mm LEFT compl
505 11 53-01	Q	Hose	522 73 41-01	L	Outer side 800mm RIGHT compl
505 11 58-01	C	Motor assy Track feeding	522 73 43-01	L	Centre section 800mm compl
505 11 59-01	C	Motor assy Arm feeding	522 73 44-01	L	Outer side 1000mm LEFT compl
505 11 65-01	E	Pivoting arm ASSY	522 73 45-01	L	Outer side 1000mm RIGHT cpl
505 11 99-01	L	Tube	522 73 47-01	L	Centre section 1000mm compl
505 12 00-01	L	Bracket	522 73 48-01	L	Outer side 1240mm LEFT compl
505 12 02-01	L	Cone	522 73 49-01	L	Outer side 1240mm RIGHT cpl
505 12 03-01	L	Cone	522 73 51-01	L	Centre section 1240mm compl
505 12 04-01	L	Shaft	522 93 08-01	B	Contact pin 0,75mm <sup>2</sup>
505 12 05-01	L	Locking plate	525 45 52-01	P	Allen key set
505 12 06-01	L	Locking plate	529 27 88-01	L	Knob
505 12 07-01	L	Locking stop	531 11 30-45	H	Track section 1,2 m
505 12 08-01	L	Locking stop	531 11 30-46	H	Track section 2,0 m
505 12 09-01	L	Cone	531 11 30-47	H	Track section 2,2 m
505 12 10-01	L	Washer	531 11 32-00	J	Mounting bracket universal Cpl
505 12 59-01	G	Rocker lever	531 11 32-46	H	Mounting bracket WS 400
505 12 60-01	G	Spring	531 11 32-47	H	Coupling link compl.
505 14 35-01	A	Type plate	531 11 32-48	H	Track holder compl.
505 15 29-01	L	Blade guard D800mm Assy	531 11 32-58	G	Guide wheel conc., compl.
505 15 30-01	L	Blade guard D1000mm Assy	531 11 32-59	G	Guide wheel exc., compl.
505 15 31-01	L	Blade guard D1240mm Assy	531 11 32-65	J	Measure rod compl.WS 400 serie
505 18 64-01	K	Parallell pin	531 11 32-68	Q	Cleaning brush with hose
505 18 65-01	K	Screw	531 11 32-71	D	Clutch trackfeeding complete
505 18 66-01	K	Stop screw	531 11 73-20	B	Contact pin 2,5mm <sup>2</sup>
505 18 74-01	K	Blade guard guide	531 11 81-13	E	Magnetic plug
505 21 61-01	F	Flange, inner	531 11 82-18	FQ	Quick coupling, male 13411 M
505 21 62-01	F	Hub	531 11 82-19	AQ	Quick coupling, female 1300 UV
505 21 63-01	F	Radial seal 60x72x4	531 11 83-05	Q	Banjo screw
505 21 64-01	F	Radial seal 50x62x7 RF	531 11 83-18	Q	Waterhose black 1/2
505 21 65-01	F	Lock ring SGA 50	531 11 83-25	Q	Hose nipple 1312
505 21 76-01	F	Blade flange compl.	531 11 83-56	A	Adaptor 1/4"-1/4"
505 21 76-02	F	Blade flange 60mm compl.	531 11 90-15	Q	Hose clamp 15-24
505 21 80-01	F	Flange, inner 130	531 11 90-39	D	Bearing washer AS 3552
505 21 81-01	F	Blade flange 130 compl.	531 11 90-42	D	Bearing AXK 3552
505 21 82-01	Q	Hose 1m	531 11 90-63	A	Grease nipple
505 21 83-01	Q	Hose 8m	531 11 90-65	P	Wrench 18 mm
505 21 84-01	Q	Hose	531 11 91-08	P	Grease gun
505 22 69-01	G	Carriage WS 400	531 11 91-46	CG	Bearing washer
505 23 85-01	A	Housing	531 11 91-49	CG	Bearing AXK 1024
505 24 66-01	A	O-ring	531 11 91-50	C	Bearing
505 24 67-01	A	Motor ASSY	531 11 91-52	H	Rubber plug GL16
505 24 70-01	B	Shackle	531 11 91-55	C	Bearing NK 19/16
505 24 72-01	E	GEAR ASSY	531 11 91-58	C	Shim 23.35x1
505 25 52-01	G	Paralel pin 4x32	531 11 91-65	LM	Blind rivet 4x12 st/st
505 25 54-01	C	Gear box depth feed ASSY	531 11 91-81	K	Washer 10.5x22
505 25 55-01	C	Gear box track feed ASSY	531 11 91-83	EJH	Washer 13x24x2

No.	Pos.	Description	No.	Pos.	Description
531 11 91-85	E	Sealing ring 1/2"	531 12 21-68	N	Guide, outer
531 11 92-02	FH	Screw M6S 12x25	531 12 21-82	K	Guide wheel shaft, upper
531 11 92-03	HJ	Screw M6S 12x30	531 12 21-83	K	Wheel
531 11 92-18	M	Screw M6S 8x25	531 12 22-43	M	Locking feather Right
531 11 92-28	C	Screw MC6S 5x14	531 12 22-44	M	Locking feather left
531 11 92-35	H	Screw MC6S 8x14	531 12 22-45	M	Lock cone
531 11 91-49	A	Nut M6 cap	531 12 22-60	M	Top holder
531 11 92-60	L	Washer 5x19x1	531 12 22-80	D	Friction plate pivoting arm
531 11 92-74	E	O-ring 29,2x3	531 12 23-38	K	Spacer
531 11 92-77	C	O-ring 31,4x1,6	531 12 23-45	L	Splash guard compl.
531 11 92-82	C	O-ring 44,17x1,78	531 12 23-49	L	Splash shield
531 11 92-90	F	O-ring 61,6x2,4	531 12 23-57	J	Friction plate
531 11 92-93	A	O-ring 80x1,6	531 12 23-58	K	Guide wheel shaft, lower
531 11 92-93	B	O-ring	531 12 23-85	N	Bar to bladeguard
531 11 93-02	C	Key 4x4x16	531 12 23-88	N	Cramp
531 11 93-26	N	Washer	531 12 23-90	N	Guide Plate
531 11 93-50	H	Screw MF6S 4x12 12.9	531 12 24-54	J	Mounting bracket
531 11 93-53	M	Screw MLC6S 6x12	531 12 24-55	J	Shaft
531 11 93-60	E	O-ring 133,0x1,78	531 12 24-56	J	Link to spring-holder
531 11 93-64	EJ	Spring 2547	531 12 24-57	J	Track-holder
531 11 93-75	D	X-Ring 114,0x1,78	531 12 24-58	J	Clamping-plate
531 11 93-76	D	O-Ring 94,97x1,78	531 12 24-59	J	Clamping-plate, nut
531 11 93-89	G	Screw MLC6S 5x10	531 12 24-60	J	Brake plate
531 11 94-13	LM	Handle Bladeguard	531 12 30-01	G	Saw carriage
531 11 94-20	J	O-ring 40x2	531 12 30-02	G	Socket
531 11 94-26	GMN	Screw K6S 6x16 10.9 fzb	531 12 30-03	G	Holder right
531 11 94-35	N	Edge list 3,3 Meter	531 12 30-04	G	Holder left
531 11 94-39	D	Bearing HK 3520	531 12 30-05	G	Concentric shaft
531 11 94-40	D	Bearing washer AS 5070	531 12 30-06	G	Excentric shaft
531 11 94-42	G	Bearing 6001-2RSH	531 12 30-07	G	Guide wheel
531 11 94-43	D	Bearing 16007	531 12 30-08	G	Nut for guidewheels
531 11 94-44	E	Bearing 61909-2RS1	531 12 30-09	G	Handle
531 11 94-45	E	Bearing 61816	531 12 30-10	G	Bar
531 11 94-46	C	Bearing washer AS 1528	531 12 30-11	G	Excentric locking shaft
531 11 94-47	E	Shaft seal BA 50x65x7	531 12 30-12	G	Locking clamp
531 11 94-48	E	O-ring 101,34x1,78	531 12 30-13	G	Sprint
531 11 94-51	E	O-ring 74,5x3	531 12 30-14	G	Excentric bushing
531 11 94-53	G	Levell	531 12 30-15	G	Feeding shaft
531 11 94-54	G	Spring	531 12 30-16	G	Shaft holder
531 11 94-56	H	Turning knob	531 12 30-17	G	Transfer gear
531 11 94-57	G	Bearing bushing	531 12 30-18	G	Nut for shaft
531 11 94-99	E	O-ring 69,5x3	531 12 30-20	A	Wear plate
531 11 95-00	D	O-ring 61x1,6	531 12 30-21	D	Feeding gear, arm
531 11 95-04	D	O-ring 71,12x2,62	531 12 30-22	D	Feeding gear, track
531 11 95-11	A	Screw K6S 8x16 10.9 fzb	531 12 30-23	D	Longitudinal feeding gear
531 11 95-26	M	Edge list 3,3 Meter WS 400	531 12 30-24	D	Tensioning nut
531 11 95-31	P	Water level to toolkit	531 12 30-25	D	Cup spring
531 11 95-32	P	Ratchet wrench to toolkit	531 12 30-26	D	Friction plate
531 11 95-33	P	Wrench 16mm to toolkit	531 12 30-27	G	Bushing
531 11 95-34	P	Socket 18mm to toolkit	531 12 30-28	C	Feeding screw
531 11 95-41	P	Socket 19mm to toolkit	531 12 30-31	E	Stub gear
531 11 95-42	A	Screw K6S 6x40 10.9 fzb	531 12 30-32	E	Medial gear
531 11 95-53	Q	Cleaning brush	531 12 30-33	F	Flange, outer
531 11 95-79	C	Screw	531 12 30-35	E	Blade shaft
531 11 95-81	F	Bearing 61810-2RS	531 12 30-40	D	Clutch plate
531 11 95-86	J	Screw MRX M3x5	531 12 30-43	E	Medial shaft
531 11 95-88	G	Seeger circlip SGA 11	531 12 30-44	E	Medial spacer
531 11 95-89	K	Screw K6S 6x20 10.9 fzb	531 12 30-46	E	Collar
531 11 96-01	E	Shaft seal 25x35x7	531 12 30-47	E	Collar plate
531 12 16-11	M	Hand wheel	531 12 30-48	F	60mm bushing
531 12 20-27	H	Gear rack 2,0m	531 12 30-51	F	Plate for hub
531 12 20-28	H	Gear rack 1,2m	531 12 30-55	C	Cover plate
531 12 20-34	C	Thrust journal	531 12 30-56	F	Water block
531 12 20-43	H	Guide track section 2,0m	531 12 30-57	F	Water connection
531 12 20-44	H	Guide track section 1,2m	531 12 30-59	LM	Rail holder
531 12 20-49	E	Sealing plug	531 12 30-63	LM	Rail
531 12 20-70	H	Safety stop	531 12 30-65	K	Roller guide
531 12 21-18	H	Clamping washer	531 12 30-66	K	Cover
531 12 21-24	H	Gear rack 2,2 m	531 12 30-70	K	Handle
531 12 21-25	H	Guide track section 2,2 m	531 12 30-71	K	Excentric shaft

No.	Pos.	Description	No.	Pos.	Description
531 12 30-73	LM	Slide rail	732 25 16-01	N	Nut M6 Nylock
531 12 30-74	P	Pin socket	732 25 22-71	EJ	Nut M12 Nylock 10.9
531 12 30-75	H	Track holder	734 11 35-71	G	Washer 4.3x8
531 12 30-76	H	Clamping plate	734 11 63-01	EH	Washer 8.4x16
531 12 30-86	LM	Rail holder 2	735 31 28-10	G	Seeger circlip
531 12 30-87	N	Handle bladeguard 1240mm	735 31 33-00	D	Seeger circlip SGA 35
531 12 30-91	N	Handle	735 31 33-10	K	Seeger circlip SGH 35
531 12 30-95	F	Water hose	738 21 10-04	D	Bearing 6010-2RS1
531 12 30-96	H	Coupling link	738 22 02-24	K	Bearing 6202-2RS1 C2
531 12 30-97	H	Clamping washer	740 38 27-01	AFQ	Sealing ring 1/4
531 12 32-12	A	Outer tube	740 42 07-00	F	O-ring 9,1x1,6
531 12 32-14	A	Mounting plate	740 42 14-00	G	O-ring 16,1x1,6
531 12 32-27	C	Input shaft	740 43 07-00	H	O-ring 9,3x2,4
531 12 32-34	C	Sun gear 166	740 43 11-00	E	O-ring 13,3x2,4
531 12 32-36	C	Output sun gear 166	740 44 05-00	F	O-ring 22,2x3
531 12 32-44	A	Saw handle WS 440 HF			
531 12 32-64	E	Pivoting arm			
531 12 32-65	E	Input shaft			
531 12 32-70	E	Back cover			
531 12 32-80	C	HAL sensor board			
531 12 32-81	B	Cover			
573 96 27-01	A	Spacer			
574 41 61-01	B	Electronic box top			
574 41 62-01	B	Electronic box			
574 45 59-01	B	Seal			
574 45 60-01	B	Seal			
574 45 61-01	B	Seal			
574 61 87-01	D	Arm shaft			
574 61 96-01	B	Motor Interface Board			
574 61 97-01	D	Key 6x6x14			
574 83 88-01	B	Sealing holder			
574 88 03-01	B	O-ring			
720 12 71-50	G	Cylindrical pin 4x18			
720 13 08-50	G	Cylindrical pin 5x16			
720 13 51-50	E	Cylindrical pin 6x16			
720 13 52-51	H	Cylindrical pin 6x18			
720 13 53-50	J	Cylindrical pin 6x20			
720 13 65-51	J	Cylindrical pin 6x50			
721 42 57-00	N	Spring pin 4x22			
723 51 93-51	C	Screw MFS 2,5x8			
723 53 66-51	F	Screw MFS 6x12			
725 25 43-51	H	Screw M6S 12x55			
725 25 44-91	E	Screw M6S 12x60			
725 25 56-51	J	Screw M6S 12x120			
725 52 20-01	C	Screw MC6S 3x6			
725 52 93-01	B	Screw MC6S 4x16			
725 53 29-01	E	Screw MC6S M5x16			
725 53 31-01	C	Screw MC6S 5x20			
725 53 33-01	A	Screw MC6S 5x25			
725 53 41-01	K	Screw MC6S 5x50			
725 53 62-01	K	Screw MC6S M6x8			
725 53 64-01	H	Screw MC6S M6x10			
725 53 68-01	GKLM	Screw MC6S 6x16			
725 53 70-01	GL	Screw MC6S 6x20			
725 54 51-01	A	Screw MC6S 8x20			
725 54 53-01	G	Screw MC6S 8x25			
725 54 64-01	E	Screw MC6S 8x65			
725 62 87-01	E	Screw MF6S 4x8			
725 62 89-01	B	Screw MF6S 4x10			
725 63 27-51	AFK	Screw MF6S 5x12 10.9			
725 63 30-51	KL	Screw MF6S 5x16 10.9			
725 63 66-51	AEF	Screw MF6S 6x12 10.9			
725 63 68-51	AEKLM	Screw MF6S 6x16 10.9			
725 63 70-51	FKN	Screw MF6S 6x20 10.9			
725 64 47-51	F	Screw MF6S 8x12 10.9 fzb			
725 64 89-51	F	Screw MF6S 10x16 10.9			
728 72 89-05	D	Stop screw S6SS 4x10			
728 83 64-05	G	Stop screw SK6SS 6x10			
731 43 20-01	GKN	Nut M10 low			
732 25 14-01	K	Nut M5 Nylock			

**A** WS 440 HF

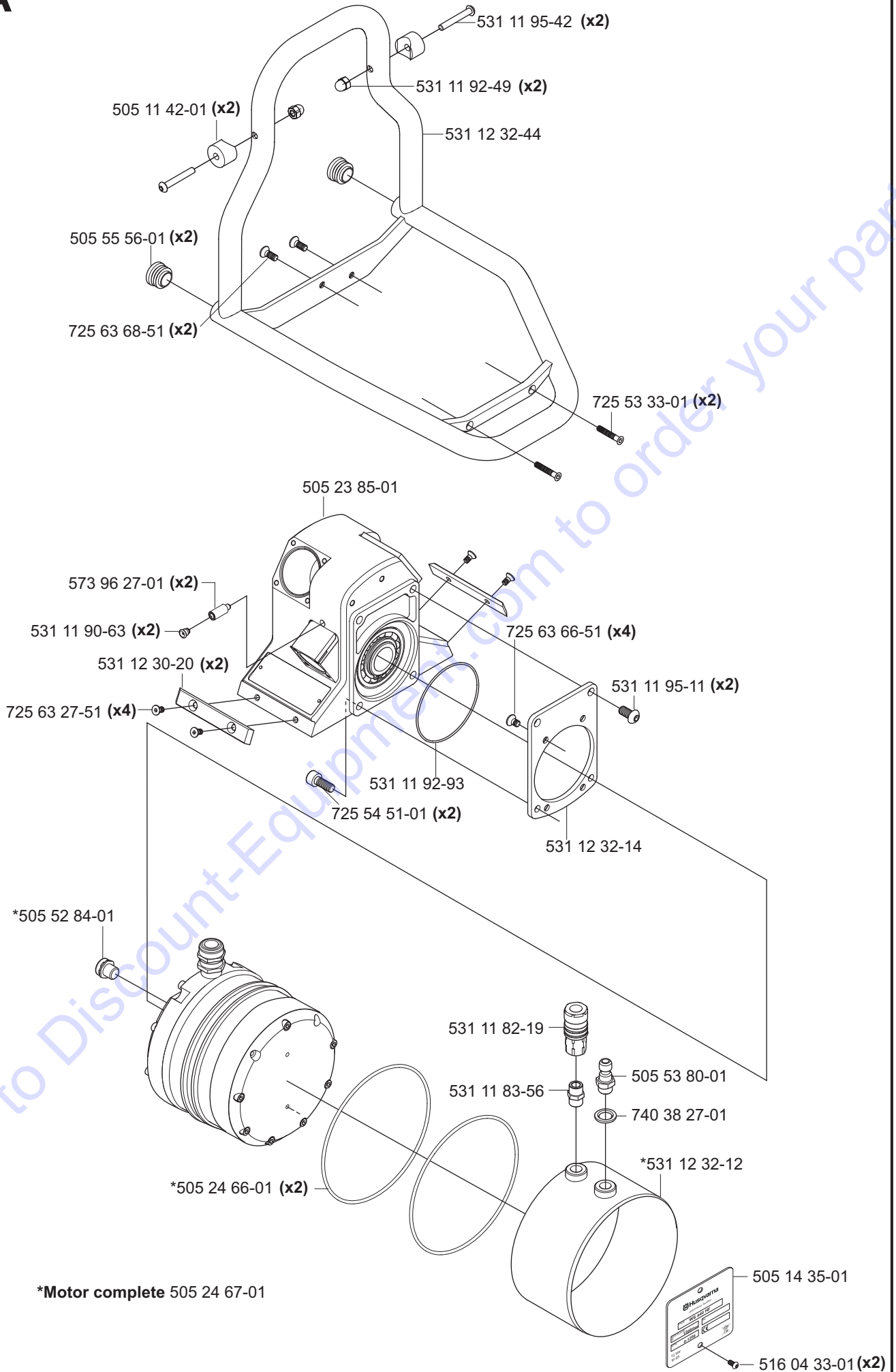

**B** WS 440 HF

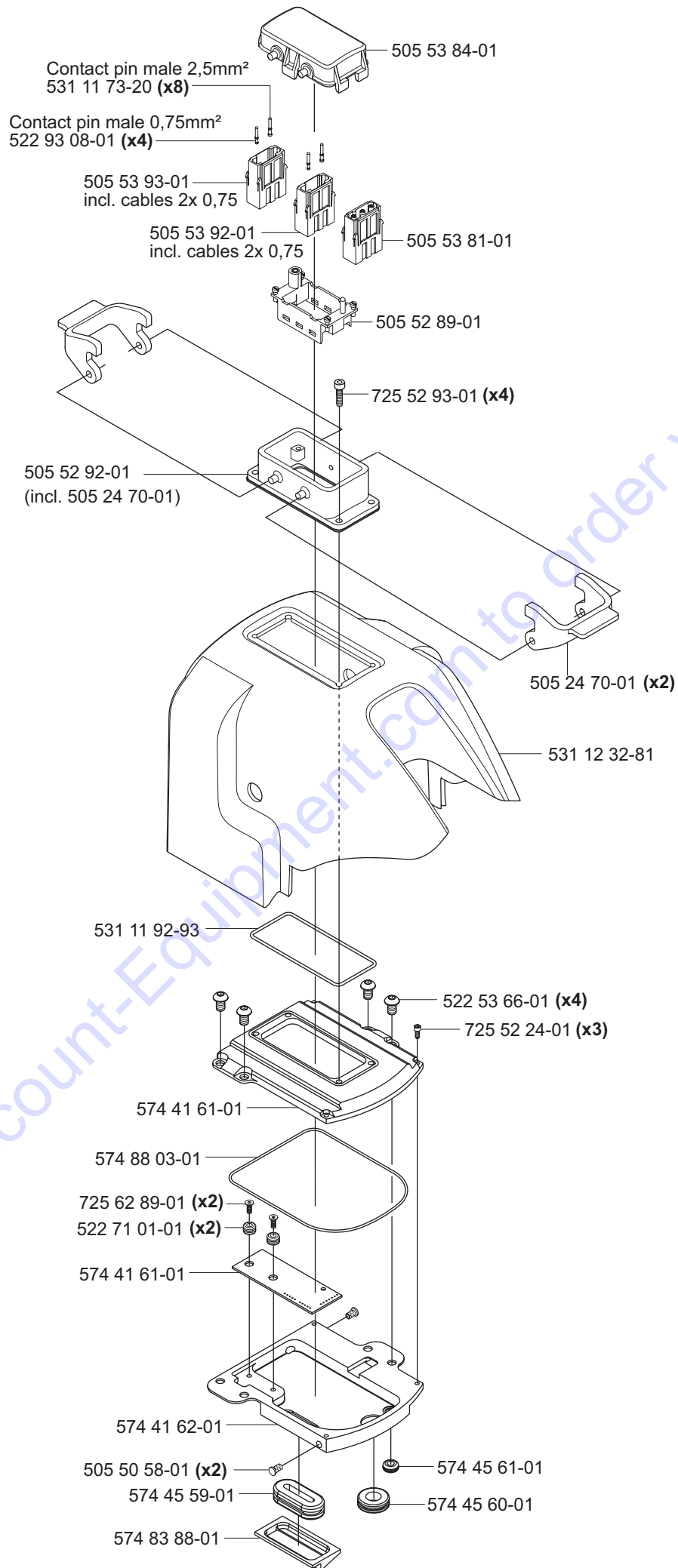

**C** WS 440 HF

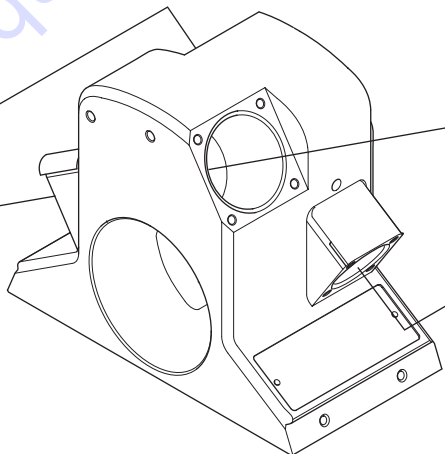
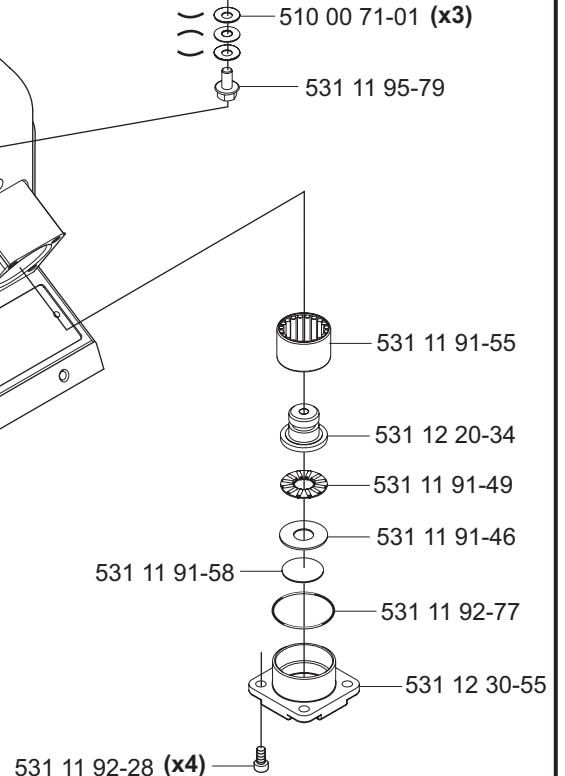
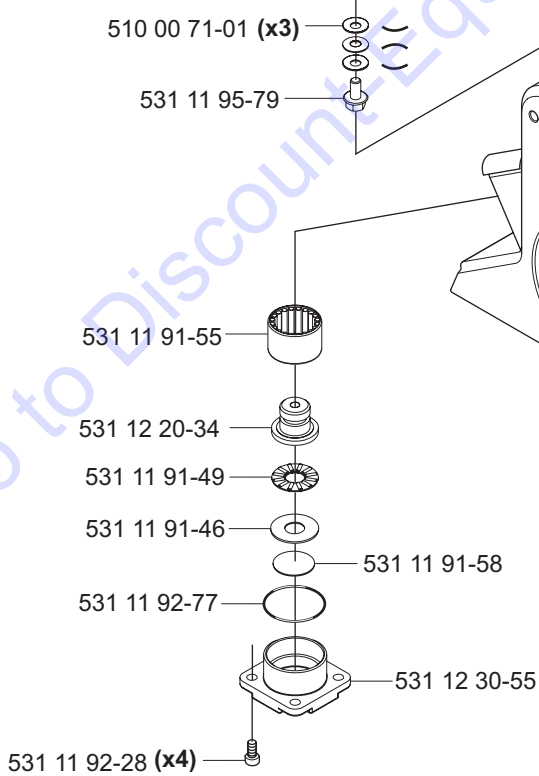
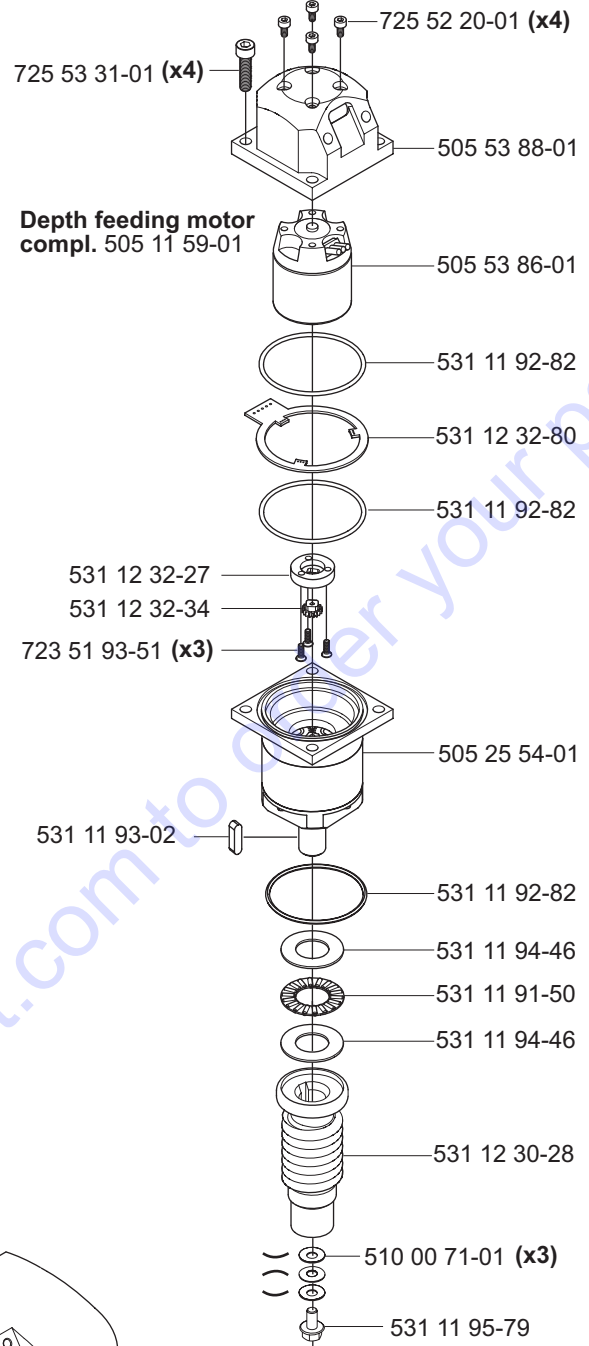
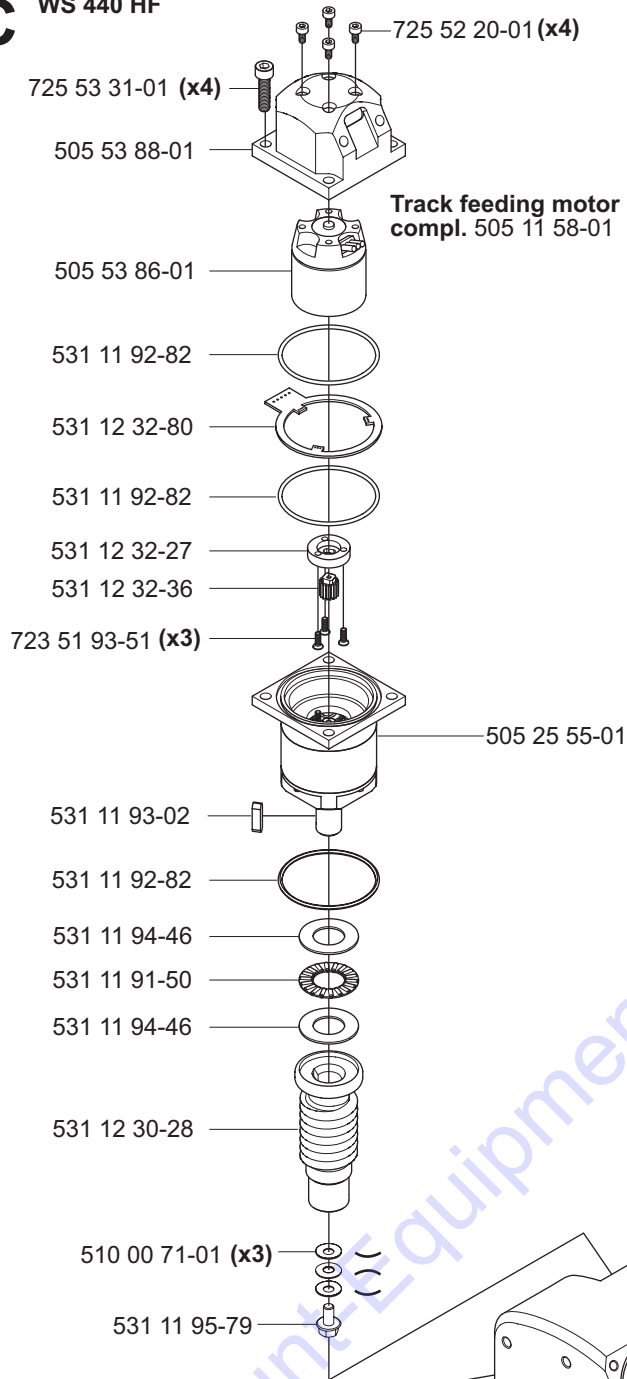



**D** WS 440 HF

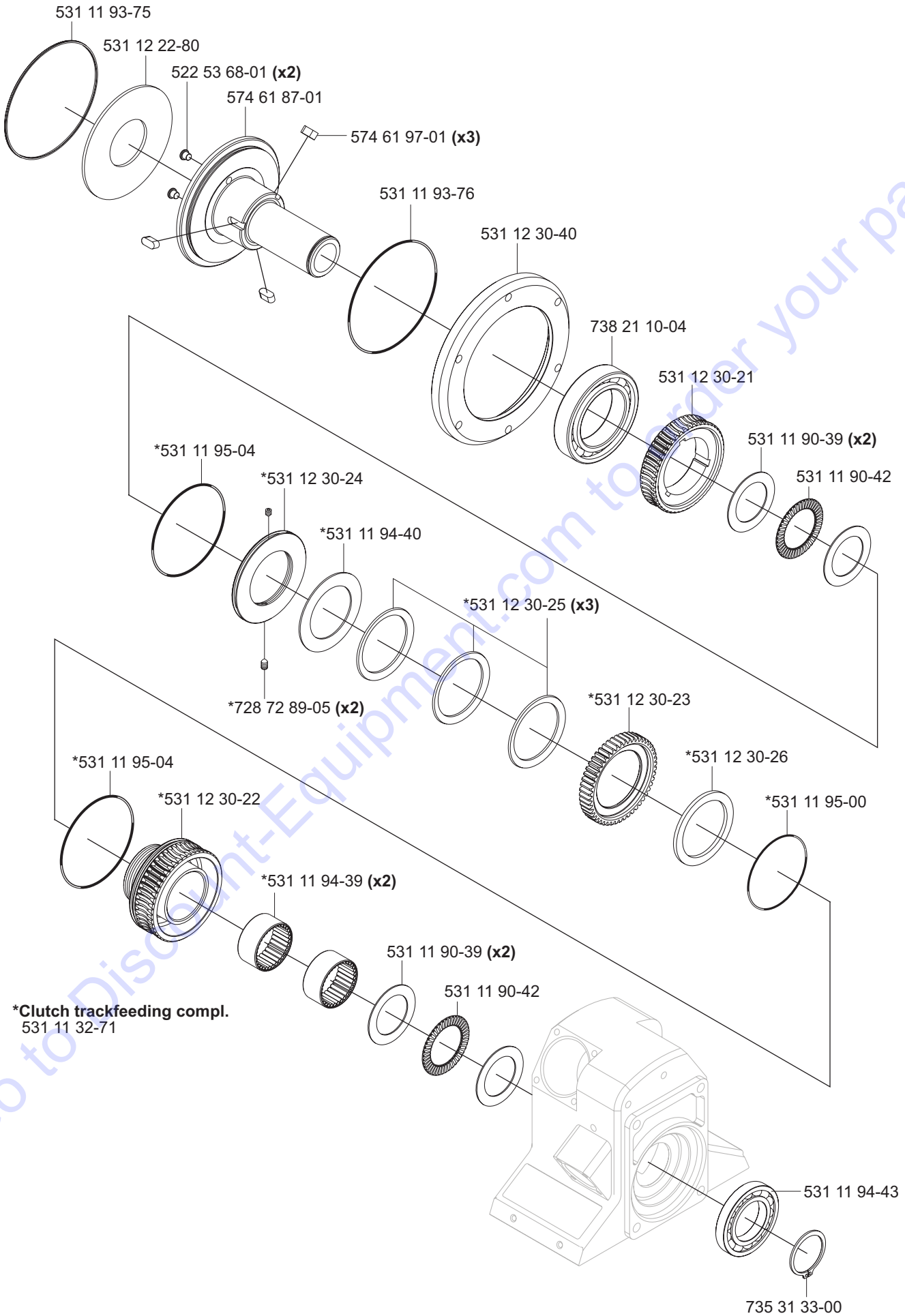

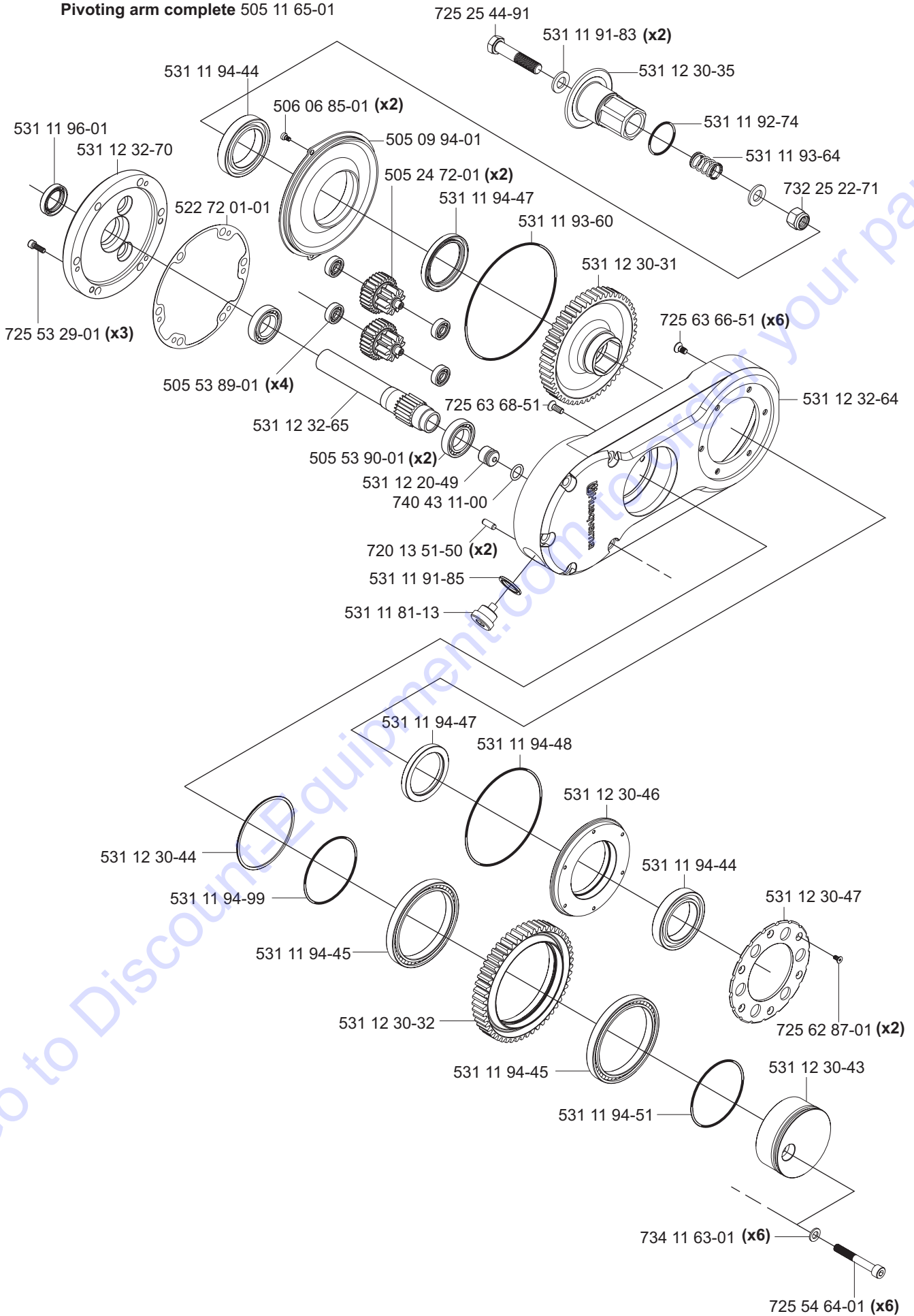
**E****WS 440 HF****Pivoting arm complete 505 11 65-01**

- Flange 1" complete      505 21 76-01
- Flange 60mm complete    505 21 76-02
- Flange 130 complete    505 21 81-01

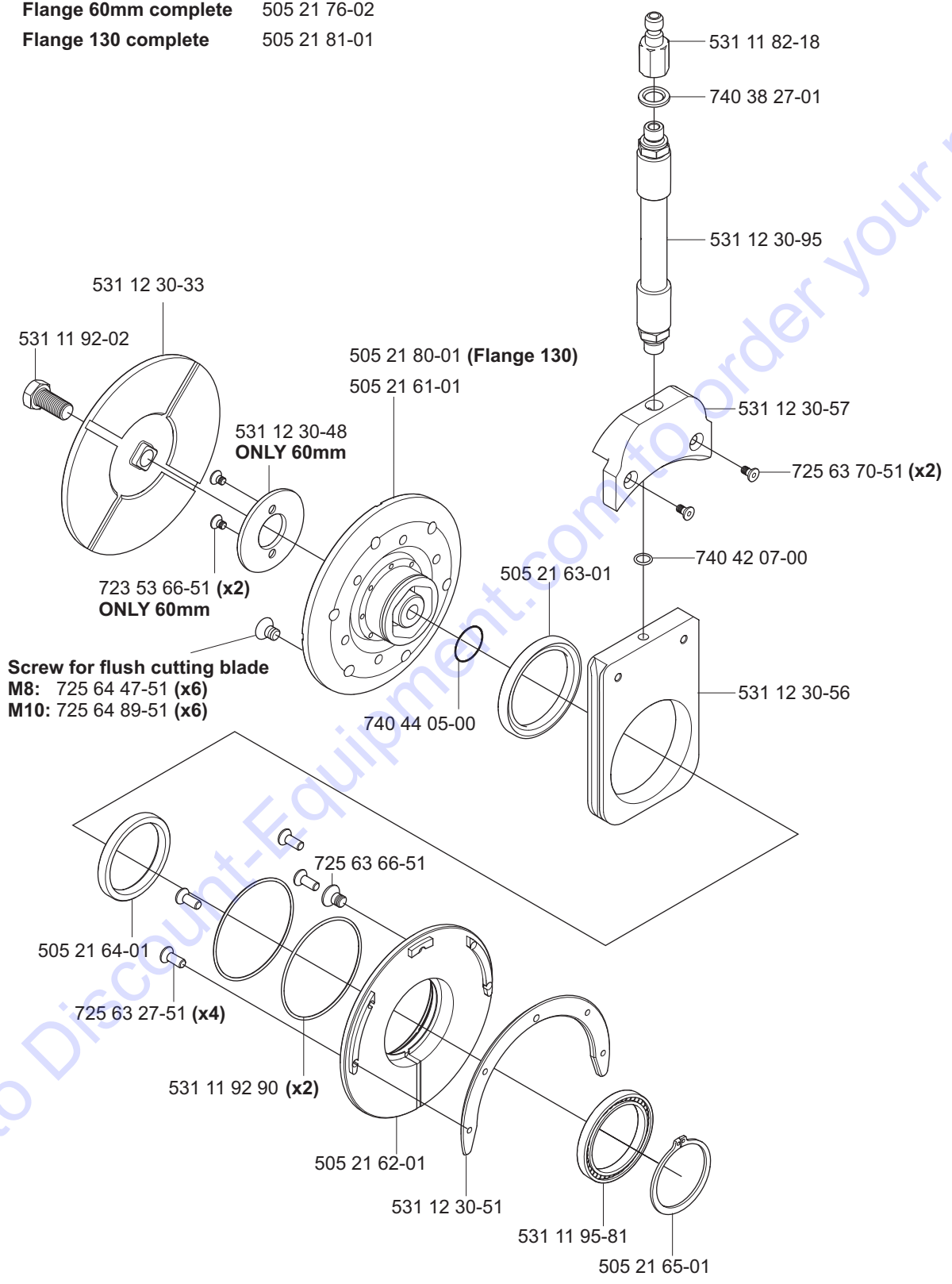

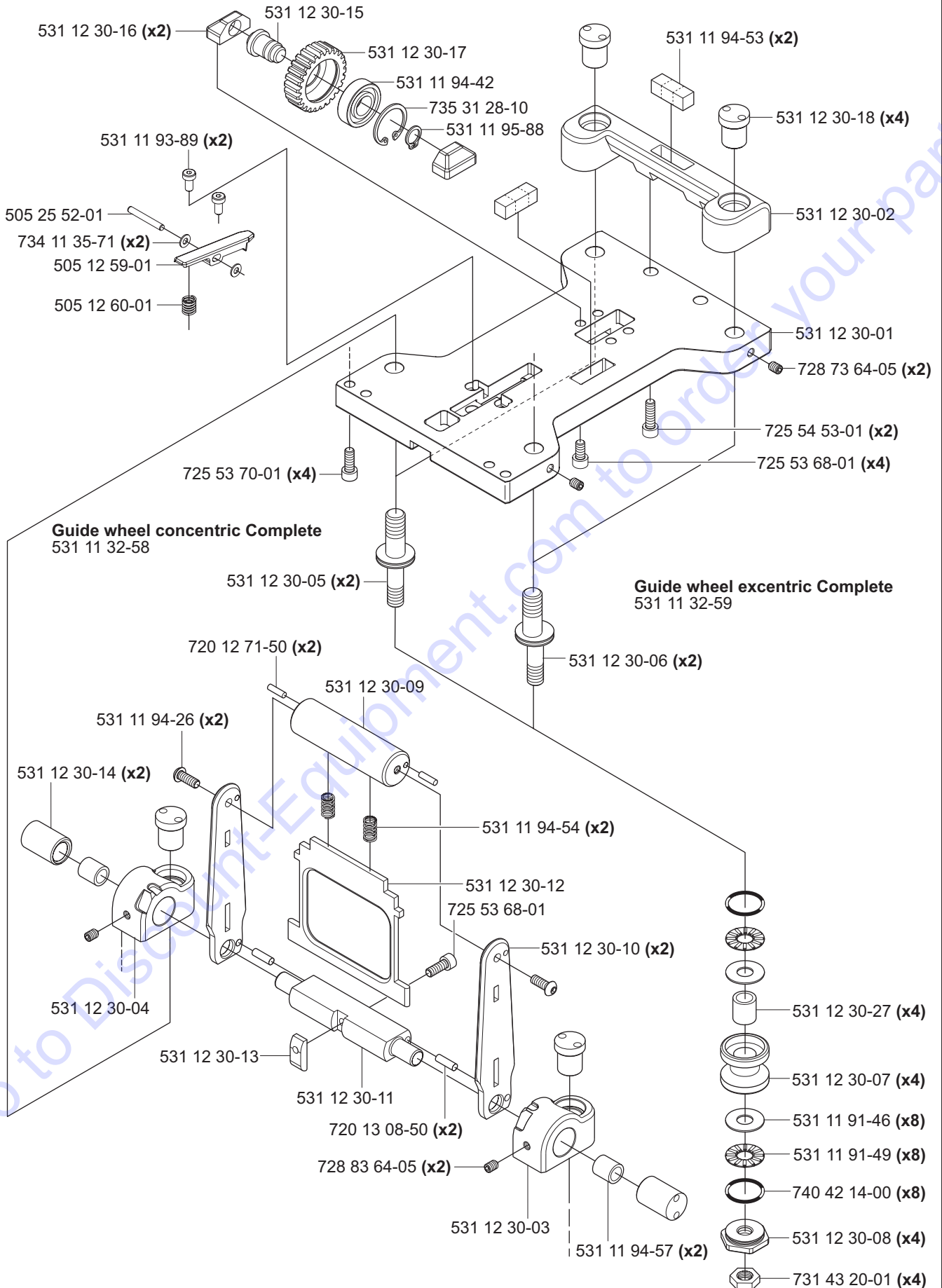
**G****WS 440 HF****Saw carriage 400 complete 505 22 69-01**

# H WS 440 HF

## Track 400 complete

1.2m 531 11 30-45

2.0m 531 11 30-46

2.2m 531 11 30-47

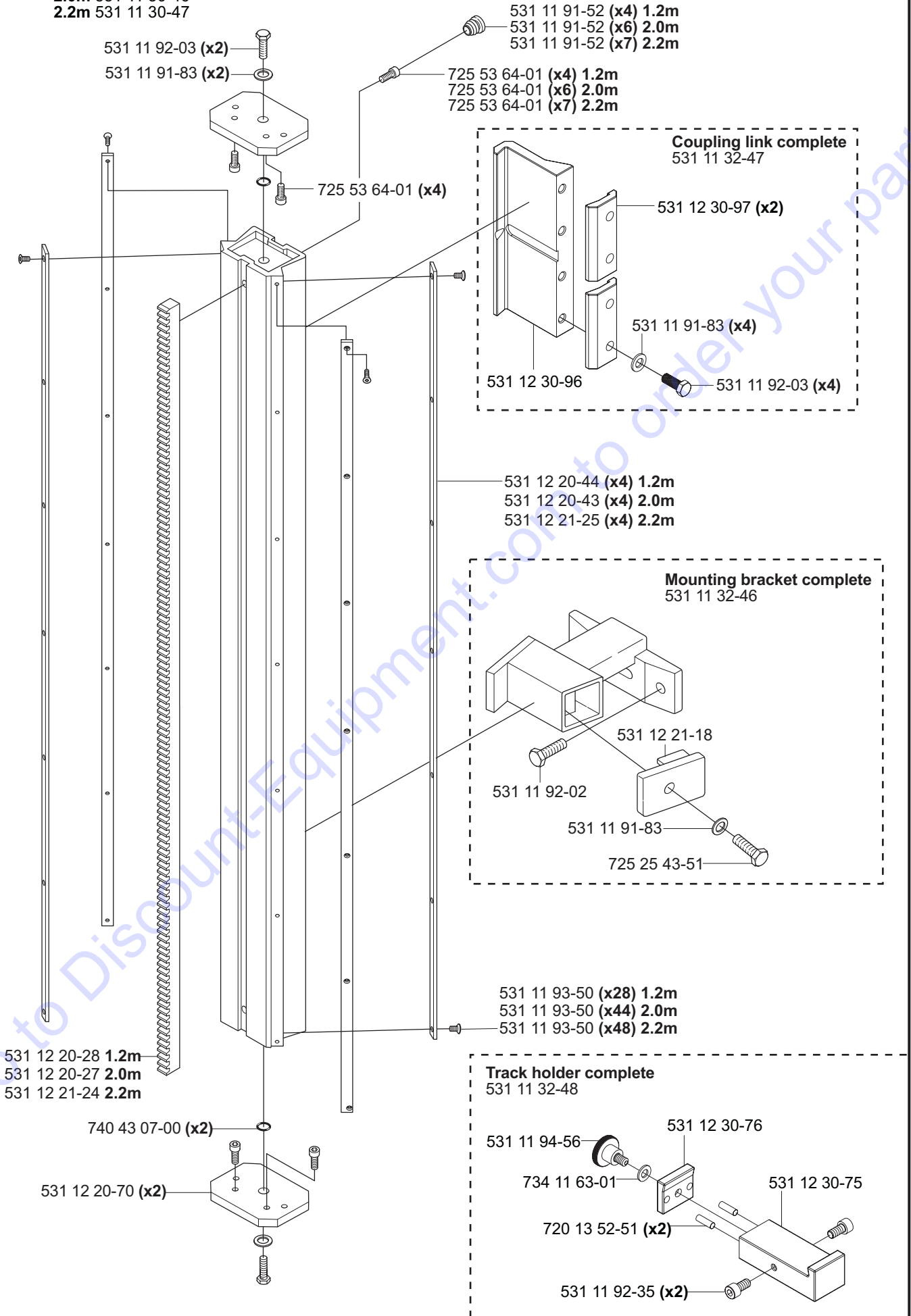

**J****WS 440 HF**

**Tillbehör  
Accessories  
Zubehöre  
Accessoires  
Accesorios**

**Mounting bracket Universal  
compl. 531 11 32-00**

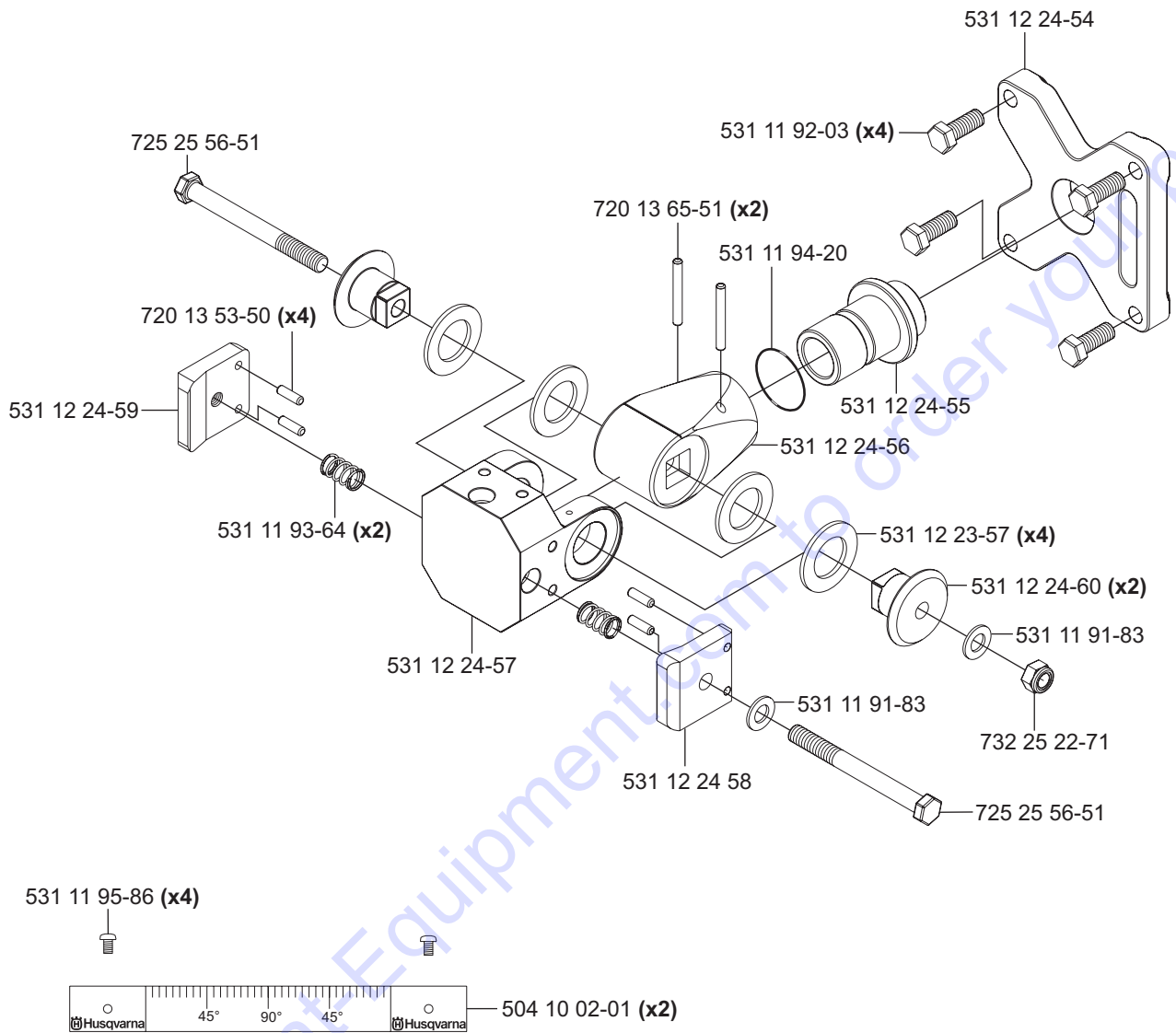

**Measure rod complete 531 11 32-65**

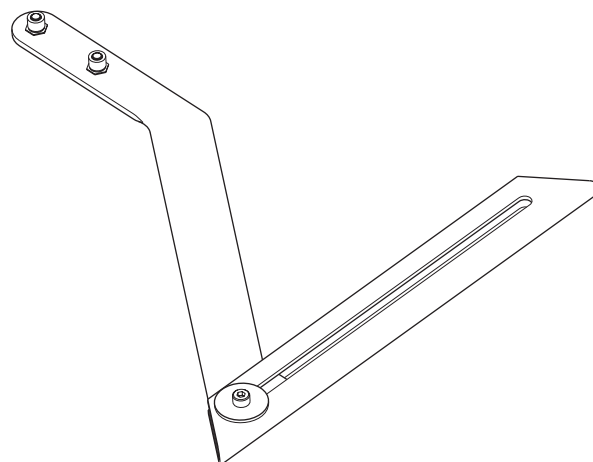

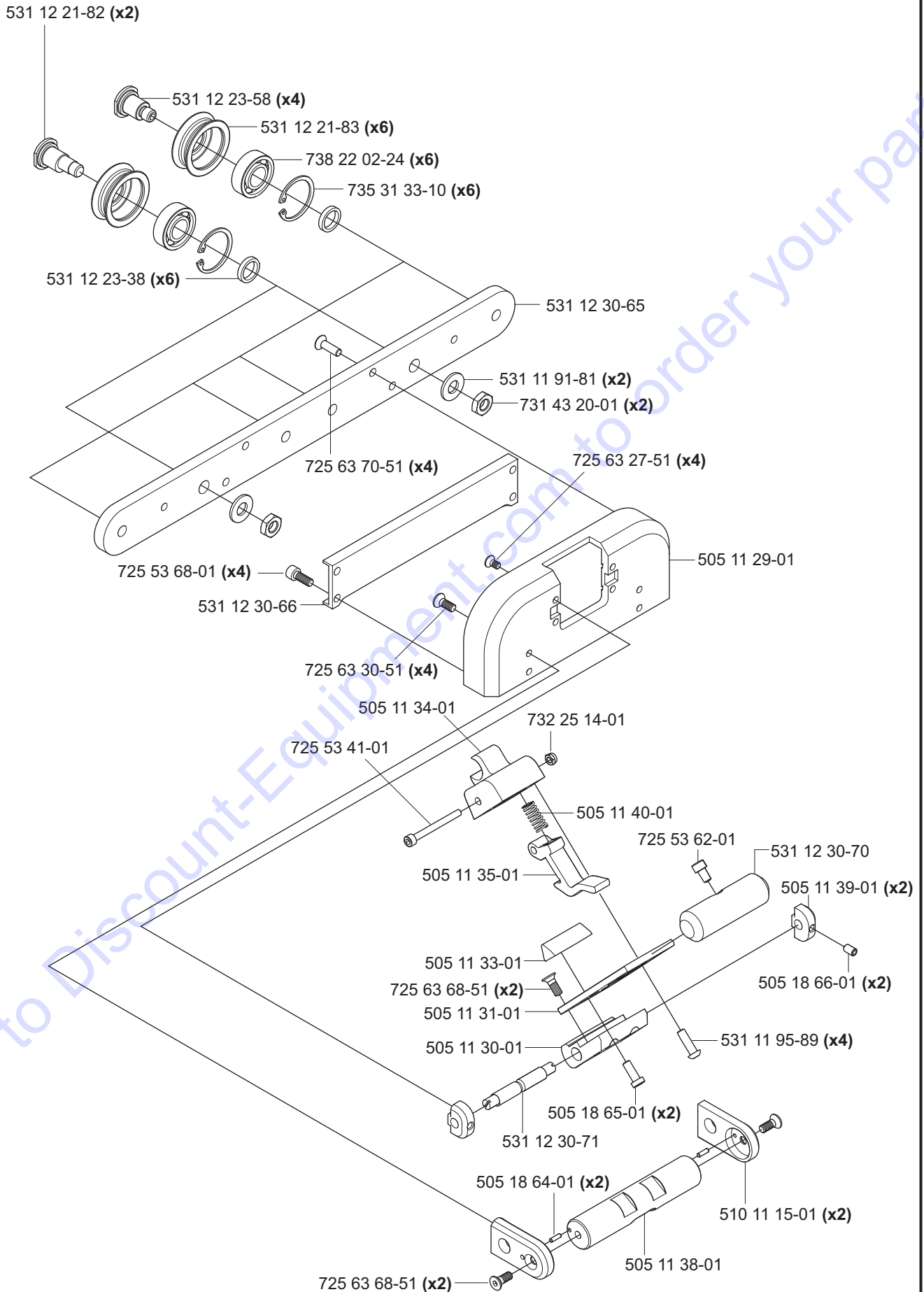
**K****WS 440 HF****Blade guard guide Complete 505 18 74-01**

L

**WS 440 HF**

**Blade guard Complete**

- 800mm 505 15 29-01 725 53 68-01(x2)
- 1000mm 505 15 30-01
- 1240mm 505 15 31-01

**Outer side, RIGHT compl.**

- 800mm 522 73 41-01
- 1000mm 522 73 45-01
- 1240mm 522 73 49-01

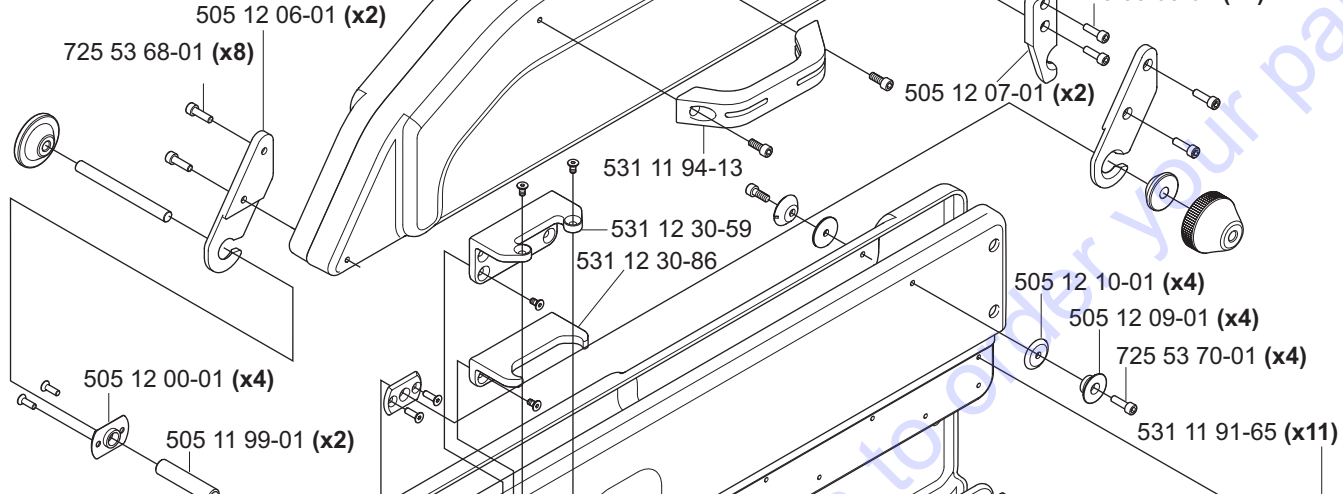

**Centre section compl.**  
 800mm 522 73 43-01  
 1000mm 522 73 47-01  
 1240mm 522 73 51-01

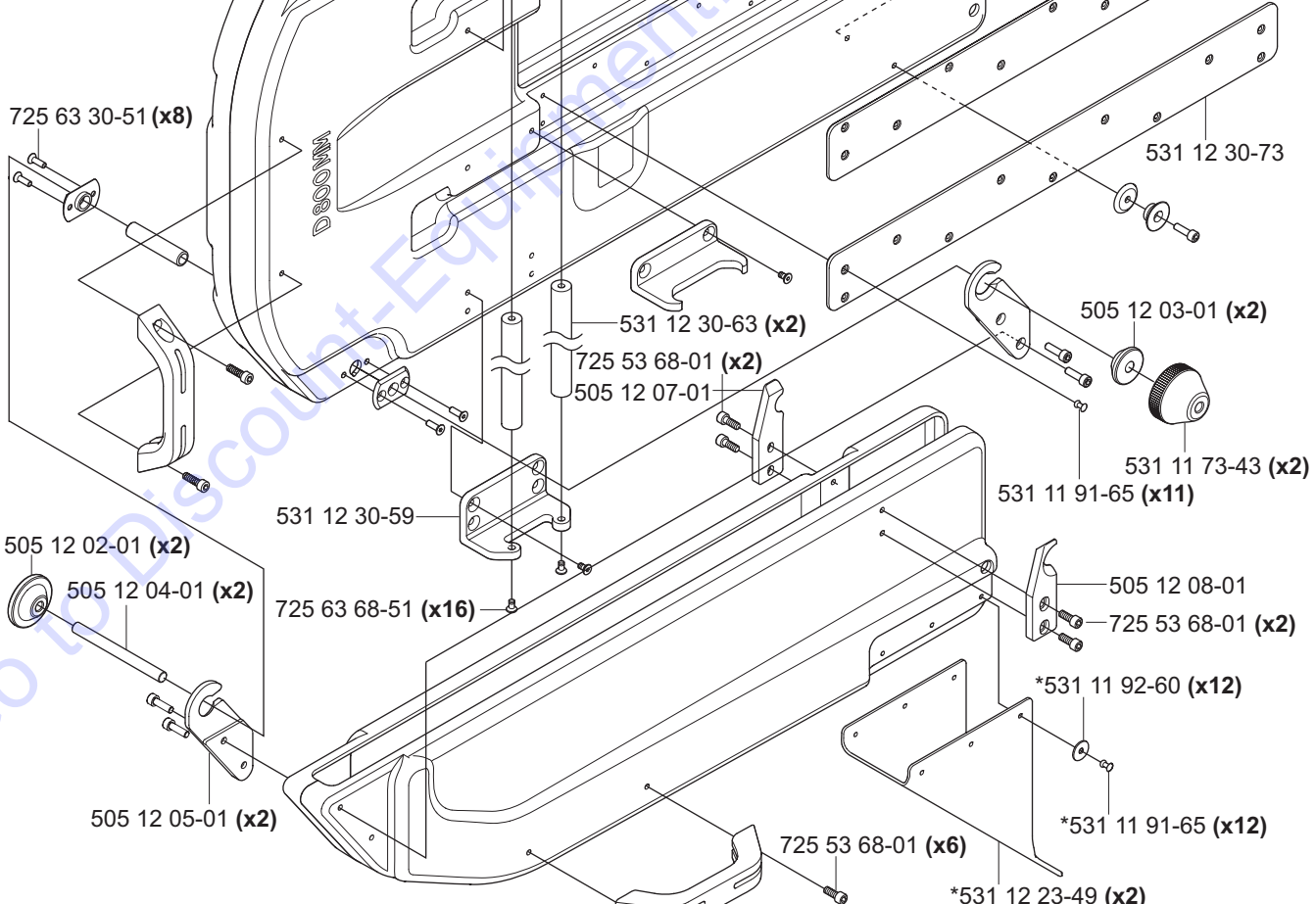

**Outer side, LEFT compl.**  
 800mm 522 73 40-01  
 1000mm 522 73 44-01  
 1240mm 522 73 48-01

\*531 12 23-45 Splash guard compl.



# M WS 440 HF

## Flush blade guard compl.

800mm 504 00 50-01

1000mm 504 00 52-01

1240mm 504 00 53-01

## Outer side, right compl.

800mm 501 37 29-01

1000mm 501 37 31-01

1240mm 501 37 33-01

## Edge list 3,3 Meter

531 11 95-26

## Outer side, left compl.

800mm 501 37 30-01

1000mm 501 37 32-01

1240mm 501 37 34-01

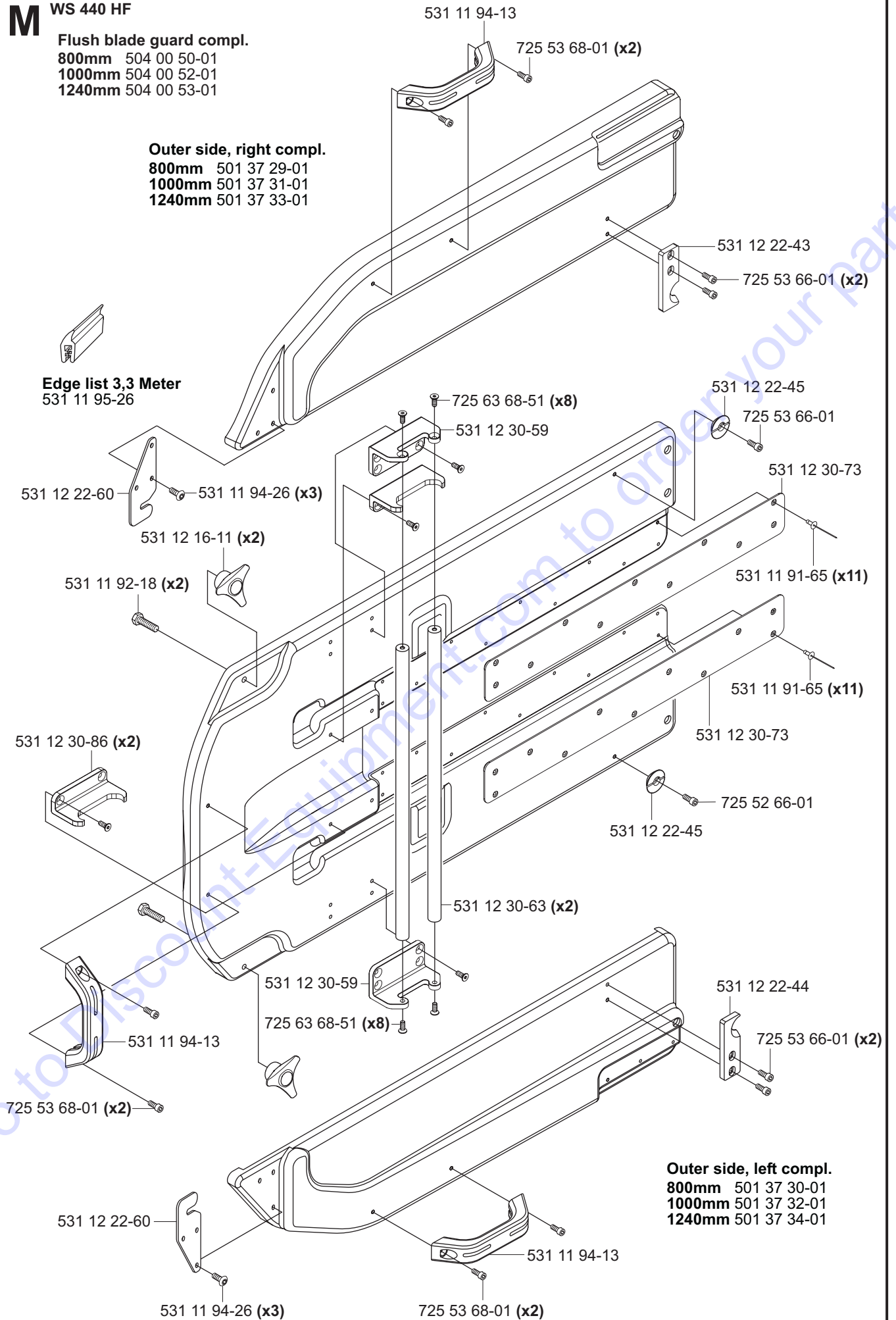

**N** WS 440 HF

**ONLY Bladeguard and Flush cut guard 1240mm**

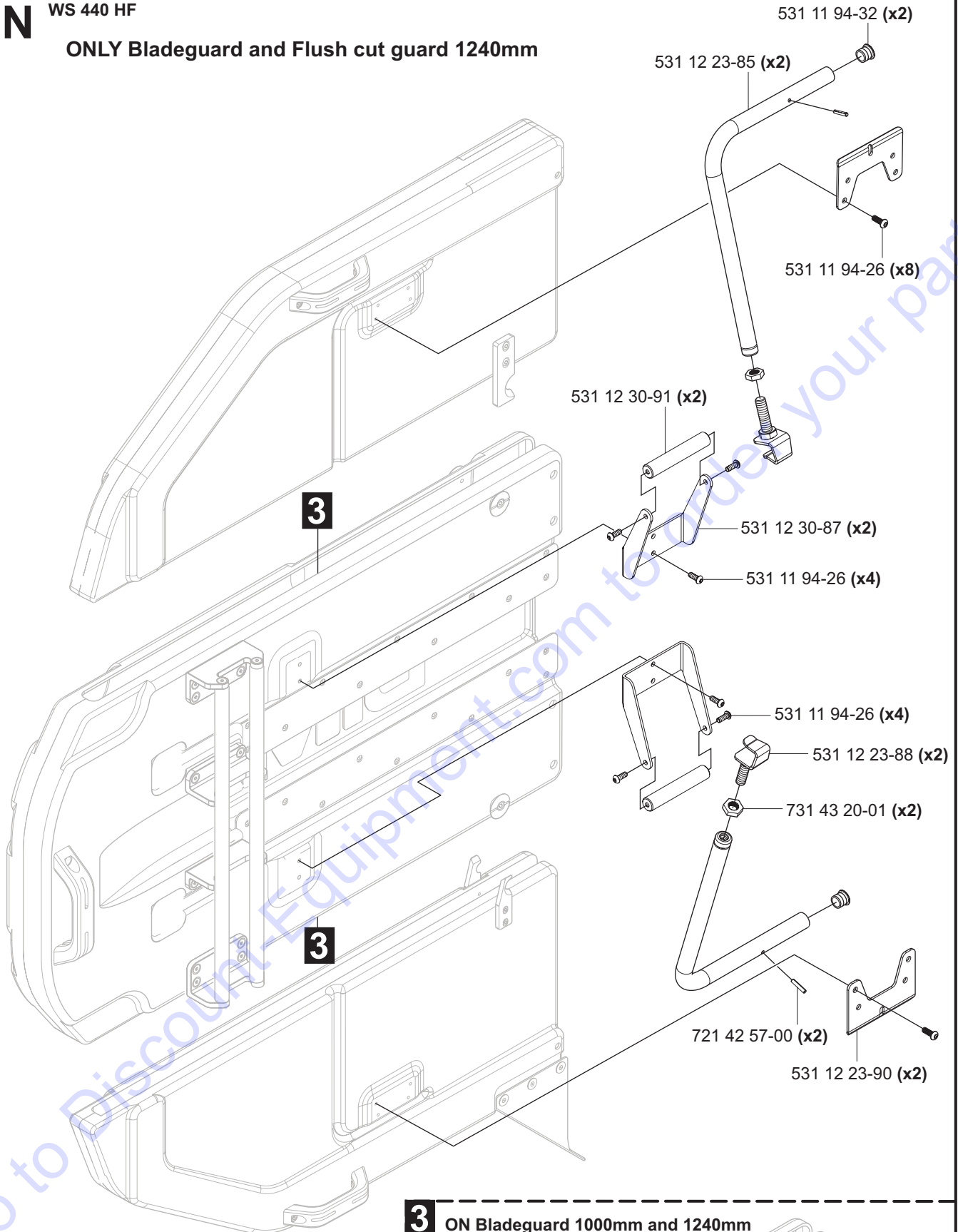

**3** ON Bladeguard 1000mm and 1240mm

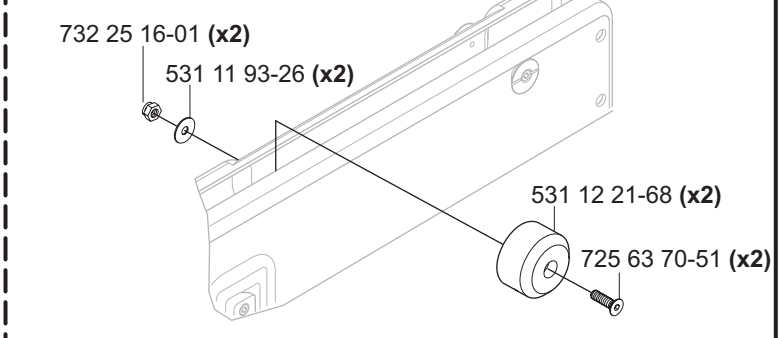

**P**

**WS 440 HF**

**Toolkit compl 501 37 52-01**

504 10 29-01

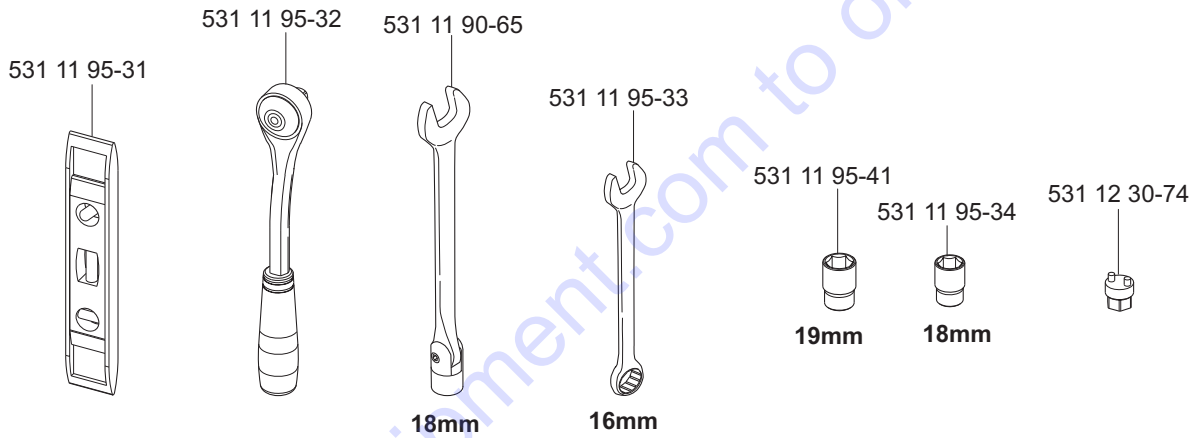
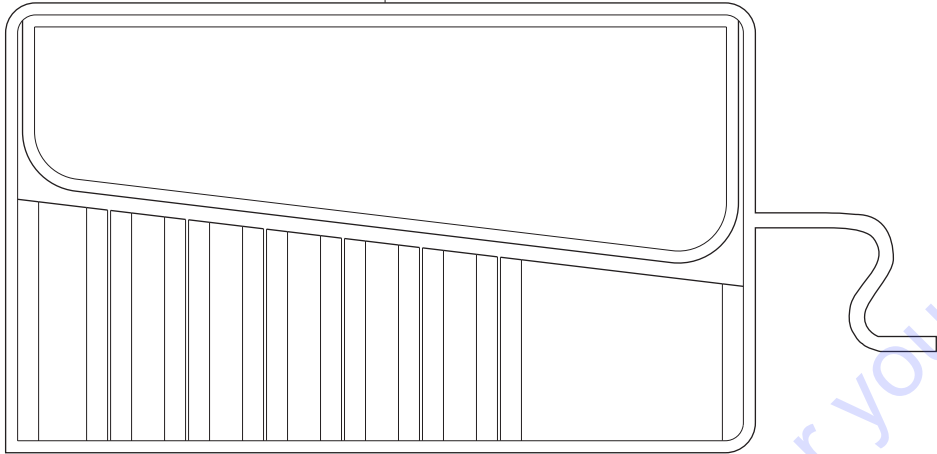

525 45 52-01

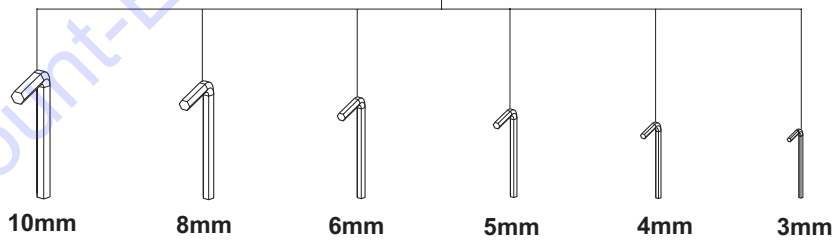

510 19 56-01



531 11 91-08

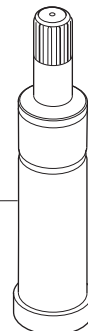

**Q**

**WS 440 HF**

**Water hose 8m 505 11 53-01**

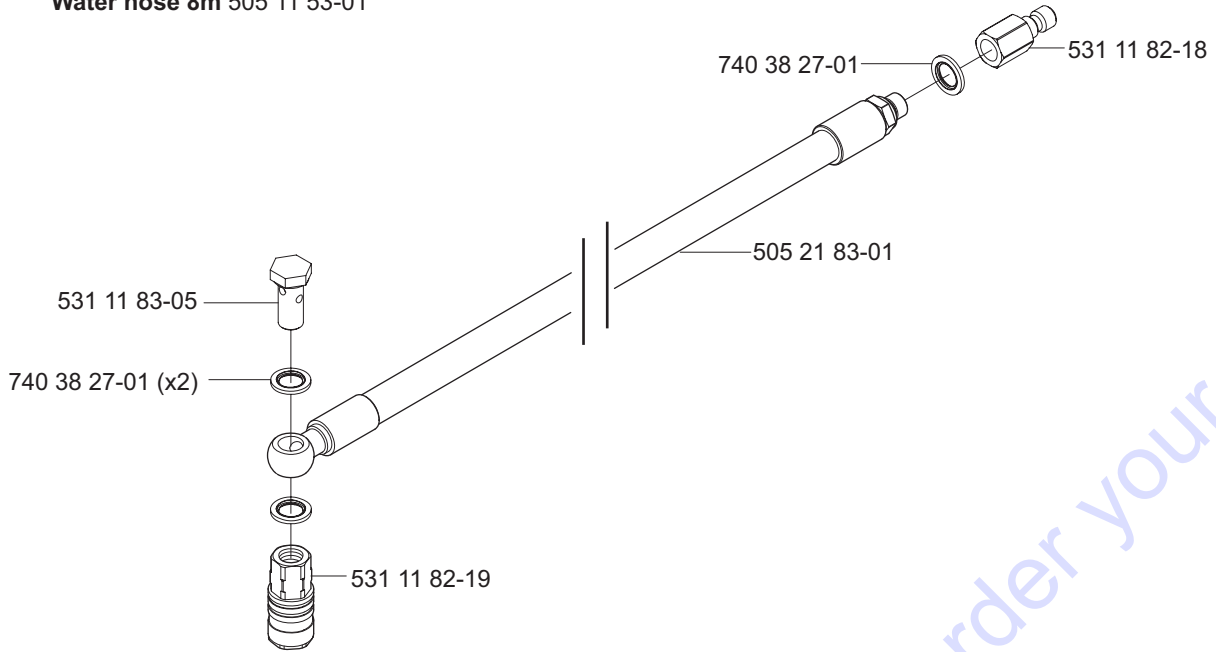

**Water hose 1m 505 21 84-01**

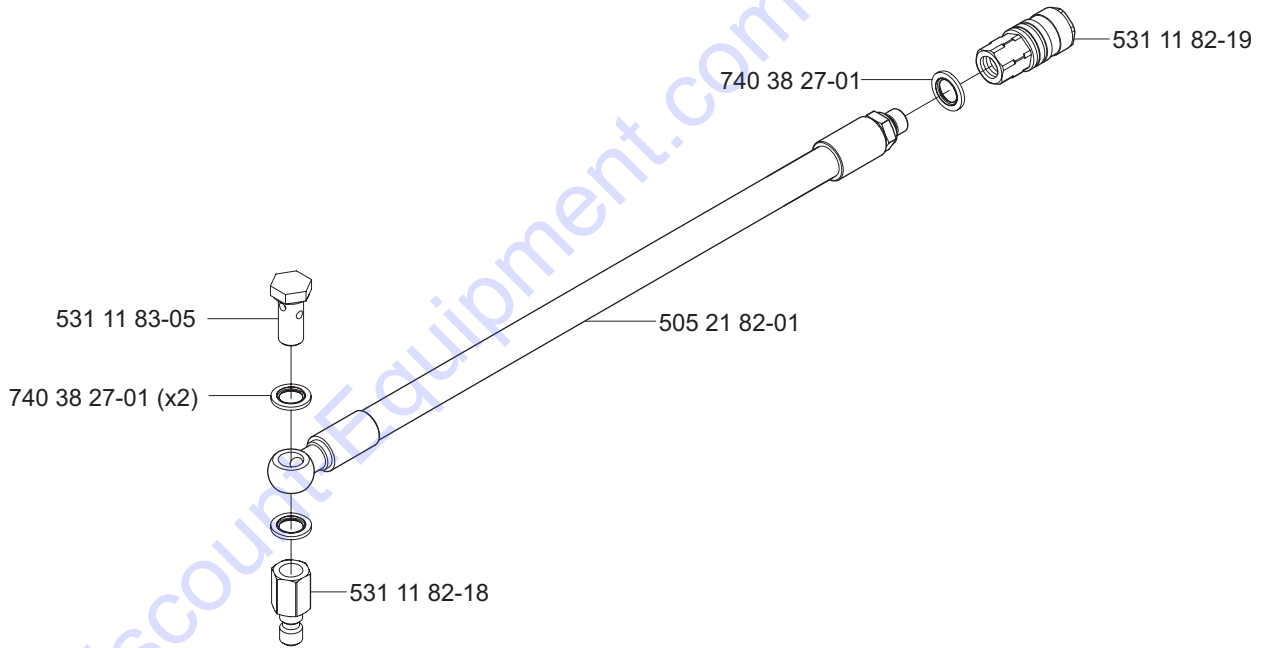

**Cleaning brush complete 531 11 32-68**



# PARTS FINDER

**Search Website  
by Part Number**



**Search Manual  
Library For Parts  
Manual & Lookup Part  
Numbers – Purchase  
or Request Quote**

**Search Manuals**

Enter your information to search for a parts manual or lookup a part number.

\* Brand:

\* Model:

\* Serial:

\* Part Number:

SEARCH

**Can't Find Part or  
Manual? Request Help  
by Manufacturer,  
Model & Description**

**Parts Order Form**

Please fill in the following information to request help finding a part or manual.

Manufacturer:

Model:

Description:

Quantity:

Part Number:

Part Name:

Part Description:

Part Category:

Part Location:

Part Status:

Part Condition:

Part Material:

Part Color:

Part Weight:

Part Dimensions:

Part Price:

Part Lead Time:

Part Availability:

Part Notes:

Submit

Discount-Equipment.com is your online resource for quality parts & equipment.

Florida: **561-964-4949** Outside Florida TOLL FREE: **877-690-3101**

**Need parts?**

Click on this link: <http://www.discount-equipment.com/category/5443-parts/> and choose one of the options to help get the right parts and equipment you are looking for. Please have the machine model and serial number available in order to help us get you the correct parts. If you don't find the part on the website or on one of the online manuals, please fill out the request form and one of our experienced staff members will get back to you with a quote for the right part that your machine needs.

We sell worldwide for the brands: Genie, Terex, JLG, MultiQuip, Mikasa, Essick, Whiteman, Mayco, Toro Stone, Diamond Products, Generac Magnum, Airman, Haulotte, Barreto, Power Blanket, Nifty Lift, Atlas Copco, Chicago Pneumatic, Allmand, Miller Curber, Skyjack, Lull, Skytrak, Tsurumi, Husquvarna Target, Stow, Wacker, Sakai, Mi-T-M, Sullair, Basic, Dynapac, MBW, Weber, Bartell, Bennar Newman, Haulotte, Ditch Runner, Menegotti, Morrison, Contec, Buddy, Crown, Edco, Wyco, Bomag, Laymor, EZ Trench, Bil-Jax, F.S. Curtis, Gehl Pavers, Heli, Honda, ICS/PowerGrit, IHI, Partner, Imer, Clipper, MMD, Koshin, Rice, CH&E, General Equipment, Amida, Coleman, NAC, Gradall, Square Shooter, Kent, Stanley, Tamco, Toku, Hatz, Kohler, Robin, Wisconsin, Northrock, Oztec, Toker TK, Rol-Air, APT, Wylie, Ingersoll Rand / Doosan, Innovatech, Con X, Ammann, Mecalac, Makinex, Smith Surface Prep, Small Line, Wanco, Yanmar