

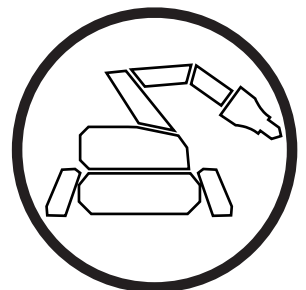

DXR-310

Please read the Operator's Manual carefully and make sure you understand the instructions before using the machine.



English

TO PURCHASE THIS PRODUCT PLEASE CONTACT US



**Equipment Financing and
Extended Warranties Available**



**Discount-Equipment.com is your online resource for
commercial and industrial quality parts and equipment sales.**

561-964-4949

visit us on line @ www.discount-equipment.com

Select an option below to find your Equipment

Search by Manufacturer

Search by Product Type

Request a Quote

We sell worldwide for the brands: Genie, Terex, JLG, MultiQuip, Mikasa, Essick, Whiteman, Mayco, Toro Stone, Diamond Products, Generac Magnum, Airman, Haulotte, Barreto, Power Blanket, Nifty Lift, Atlas Copco, Chicago Pneumatic, Allmand, Miller Curber, Skyjack, Lull, Skytrak, Tsurumi, Husquvarna Target, Stow, Wacker, Sakai, Mi-T-M, Sullair, Basic, Dynapac, MBW, Weber, Bartell, Bennar Newman, Haulotte, Ditch Runner, Menegotti, Morrison, Contec, Buddy, Crown, Edco, Wyco, Bomag, Laymor, EZ Trench, Bil-Jax, F.S. Curtis, Gehl Pavers, Heli, Honda, ICS/PowerGrit, IHI, Partner, Imer, Clipper, MMD, Koshin, Rice, CH&E, General Equipment, Amida, Coleman, NAC, Gradall, Square Shooter, Kent, Stanley, Tamco, Toku, Hatz, Kohler, Robin, Wisconsin, Northrock, Oztec, Toker TK, Rol-Air, APT, Wylie, Ingersoll Rand / Doosan, Innovatech, Con X, Ammann, Mecalac, Makinex, Smith Surface Prep, Small Line, Wanco, Yanmar

CONTENTS

Contents

INTRODUCTION

Dear Customer	4
Good service	4
Serial Number.....	4
Applications.....	4
User responsibility	4
The manufacturer's reservation	4

KEY TO SYMBOLS

Symbols on the machine.....	5
-----------------------------	---

SAFETY INSTRUCTIONS

Warning instructions.....	6
Protective equipment	6
General safety warnings.....	7
General working instructions.....	8
The machine's safety features.....	13
External environmental factors.....	15

PRESENTATION

The machine's functions.....	16
What is what in the machine?	17

HYDRAULIC SYSTEM

General	18
Main pressure.....	18
Pressure cut-off.....	18
Cooler.....	18
The machine's hydraulic system	19

ELECTRICAL SYSTEM

General	20
High-voltage circuit	20
Low-voltage circuit.....	20
The machine's electric system	21

CONTROL SYSTEM

General	22
Remote control.....	22
Signal transmission	22
Battery	22
The machine's software.....	22
What is what on the remote control?	23
Symbols on the remote control	24

STARTING AND STOPPING

Before starting.....	25
Starting	25
Stopping.....	25
Inspection after work.....	25

OPERATION

Operating modes.....	26
Option.....	26
Key to commands	26
Designation of the machine's parts.....	26
Work mode	27
Set-up mode	28
Transport mode	29

TOOLS

General	30
Work mode	30
Changing tools	31
Storage.....	31

SETTINGS

Track widener	32
Menu system.....	33
Operational settings	34

MAINTENANCE AND SERVICE

General	35
Measures to take in advance of maintenance, service and trouble shooting.....	35
Cleaning	36
Service schedule	37
Service review	40

TROUBLE SHOOTING

Error messages	47
Troubleshooting schedule	48

TECHNICAL DATA

Guide values for main connection.....	50
The hydraulic system pressure.....	50
Hydraulic fluid and lubricant.....	51
Preset limit values	51
Technical data	52

US WARRANTY STATEMENT

Warranty policy.....	55
Equipment	55

INTRODUCTION

Dear Customer

Thank you for choosing a Husqvarna DXR-310!

We hope you will find this operator's manual very useful. By following its instructions (on operation, service, maintenance, etc.) you will significantly extend the life of the machine and even its second-hand value.

Serial Number

The machine's serial number is indicated on a plate located on the hydraulic tank. Stated on the plate are:

- The machine's type designation
- Weight
- The manufacturer's type number
- The machine's serial number
- Manufacturer

The hydraulic pump and hydraulic motors are fitted with rating plates that indicate article number and the machine manufacturer's manufacture number.

Please state the type designation and serial number when ordering spare parts and for service matters.

Applications

The machine is intended for:

- Demolishing, fragmenting, cutting, detaching, separating, picking up and distributing parts of buildings and constructions.
- Use in risky environments where the operator can control the machine without being present within the risk area.
- Use both indoors and outdoors.
- Use in dangerous environments where the machine is exposed to risk of collapse, hazardous substances, great heat, etc.
- Use in environments classified as 'flammable' provided that it has the correct power connection and all its equipment is correctly dimensioned and undamaged. The operator must take the risk of spark formation into consideration when working in flammable environments..

The machine is NOT intended for:

- Use in areas classified as 'explosive'.
- Use in water where the level risks damaging the machine's equipment.
- Operation on a public highway.
- Use as a towing vehicle, means of transport or lifting device.
- Use in environments where there is danger for the operator or the life and health of people in the vicinity.
- Use in applications or environments that are not compatible with the recommendations in this Operator's Manual.

User responsibility

It is the owner's/employer's responsibility that the operator has sufficient knowledge about how to use the machine safely. Supervisors and operators must have read and understood the Operator's Manual. They must be aware of:

- The machine's safety instructions.
- The machine's range of applications and limitations.
- How the machine is to be used and maintained.

The manufacturer's reservation

Husqvarna Construction Products reserves the right to alter specifications and instructions for the machine without prior notification. The machine may not be modified without the manufacturer's written permission. If the machine is modified after delivery from Husqvarna Construction Products and without the manufacturer's written permission, it is the owner's responsibility.

Modification can entail new risks for operators, the machine and the surroundings. These can include impaired strength or inadequate protection. It is the responsibility of the owner to specify which alterations are going to be made and to contact Discount-equipment for approval before commencing the modifications.

All information and all data in the Operator's Manual were applicable at the time the Operator's Manual was sent to print.

KEY TO SYMBOLS

Symbols on the machine



WARNING! The machine can be dangerous if used incorrectly or carelessly, and can cause serious or fatal injury to the operator or others.



Please read the Operator's Manual carefully and make sure you understand the instructions before using the machine.



Noise emission to the environment according to the European Community's Directive. The machine's emission is specified in chapter Technical data and on label.



Always wear:

- Tight-fitting, heavy-duty and comfortable clothing that permit full freedom of movement.
- Sturdy, non-slip boots or shoes.
- Protective gloves.
- Protective helmet.
- Hearing protection.
- Protective goggles or visor.
- A breathing mask, gas mask or fresh air helmet must be used when working in environments where the air can be harmful to health.



WARNING! High-voltage current.



WARNING! Ensure that no material can fall down and cause damage when you are using the machine.



WARNING! Watch out for demolition material becoming loose when cutting. Use personal safety equipment and keep your distance.



WARNING! Always position yourself above the machine when driving on a slope. There is a risk of the machine tipping.



WARNING! Exercise particular caution when working close to edges. Ensure that the machine is stable and does not move closer to the edge while the work is in progress. Ensure that the underlying surface has satisfactory bearing capacity.

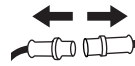

Inspections and/or maintenance must be carried out with the motor switched off and the power cord disconnected.

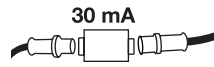

Always connect the machine through an earth-fault breaker with personal protection, i.e. an earth fault circuit breaker that trips at an earth fault of 30 mA.



Ensure that the power cable cannot be run over. Take particular care when moving or when the outriggers are being retracted or extended. Risk of electric shock.



The lifting equipment must be attached at all the machine's lifting points.

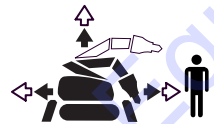

Keep your distance! Nobody is permitted to be within the machine's risk area when work is underway. The machine's risk area can vary during the course of the work.



The machine can overturn during work. During operation the machine must be positioned as level as possible and the outriggers must be fully extended.



This product is in accordance with applicable EC directives.

SAFETY INSTRUCTIONS

Warning instructions

Warning



WARNING!

Used if there is a risk of serious injury or death for the operator or damage to the surroundings if the instructions in the manual are not followed.

Important



IMPORTANT!

Used if there is a risk of injury to the operator or damage to the surroundings if the instructions in the manual are not followed.

Note

NB! Used if there is a risk of damage to materials or the machine if the instructions in the manual are not followed.

Protective equipment

Personal protective equipment



WARNING!

You must use approved personal protective equipment whenever you use the machine. Personal protective equipment cannot eliminate the risk of injury but it will reduce the degree of injury if an accident does happen. Ask your dealer for help in choosing the right equipment.

Always wear:

- Protective helmet.
- Hearing protection.
- Protective goggles or a visor.
- Tight-fitting, heavy-duty and comfortable clothing that permits full freedom of movement.
- Protective gloves.
- Sturdy, non-slip boots or shoes.
- A breathing mask, gas mask or fresh air helmet must be used when working in environments where the air can be harmful to health.
- Always have a first aid kit nearby.

Other protective equipment

- Fall protection must be used when working at height or if there is a risk of collapse. The operator and the machine must be safeguarded with separate fall protection.
- Screening equipment and modified protective clothing must be used when working in hot environments.
- Barriers must be used to inform people in the vicinity of the machine's risk area.
- Equipment must be used to secure machine parts during maintenance and service.

SAFETY INSTRUCTIONS

General safety instructions



WARNING!

Please read the Operator's Manual carefully and make sure you understand the instructions before using the machine.

The machine is used in a large range of environments and for different types of work, making it impossible to forewarn of all risks. Always exercise care and use your common sense. Avoid all situations which you consider to be beyond your capability. If you still feel uncertain about operating procedures after reading these instructions, you should consult an expert before continuing.

Do not hesitate to contact Discount-equipment if you have any more questions about the use of the machine. We will willingly be of service and provide you with advice as well as help you to use your machine both efficiently and safely.

Use the safety instructions as guidelines and support so that you can detect possible risks yourself and take measures to prevent them.

Let Discount-equipment regularly check the machine and make essential adjustments and repairs.

Management and operator

The management and the operator are responsible for identifying and preventing risks so that staff and equipment are not exposed to danger.

Responsibility

It is the responsibility of the management and the operator to confirm:

- National and local laws, regulations and other directions are followed. This might concern protective equipment, limit levels for noise, barriers, etc.
- The operator has the relevant training and experience to be able to perform the work safely.
- Unauthorized persons are not permitted to enter areas where there is a risk of accidents.
- Nobody is permitted to be within the machine's risk area when work is underway.
- Persons who are admitted to the work area are trained in and have access to protective equipment.
- The machine is used solely for the functions for which it is intended.
- The machine is used safely.
- The machine is correctly connected to a suitable power supply and correctly fused.
- The operator is informed of the work area surroundings, e.g. strength in the floor structure, positioning of load-bearing walls, cables and pipes.

Requirements of the operator

- The operator must be given sufficient information and training to have satisfactory knowledge of the machine's functions, properties and limitations.
- The operator must try to foresee risky elements of the job and assess the machine's risk area. Always exercise caution and use common sense!
- It is the responsibility of the operator to suspend work with the machine if a safety risk arises and ensure that the machine is not used by mistake. The machine must not be put into operation before the safety risk has been eliminated.
- The operator must not be under the influence of drugs or anything else that can affect his/her reactions or judgement.
- The operator must use protective equipment suited for the particular work situation.
- The operator must ensure that the machine cannot be used by unauthorized persons, e.g. do not leave the remote control unattended.

If there is an accident

It is the responsibility of the employer to produce an action plan and train operators how to deal with incidents. First take action to save human life and second to avoid material damage. Learn how to administer first aid!

Measures to take in the event of an accident:

- Get an overview. Is anyone injured? Is anyone still in the area where the accident took place?
- Alert emergency services and be prepared to provide information.
- Administer first aid and prepare a route for the emergency personnel.
- Ensure that someone accompanies the injured to the hospital.
- Secure the scene of the accident.
- Contact Discount-equipment.
- Investigate the cause of the accident.
- Put measures in place to prevent future accidents.
- Always notify Husqvarna Construction Products in the event of near-accidents or accidents regardless of whether the machine was directly or indirectly involved in the incident.

SAFETY INSTRUCTIONS

General working instructions



WARNING!

Read all safety warnings and all instructions. Neglecting to follow the warnings and instructions can lead to serious injury or death for the operator or others..

This section describes basic safety directions for using the machine. This information is never a substitute for professional skills and experience. If you get into a situation where you feel unsafe, stop and seek expert advice. Contact Discount-equipment!

Work area safety

The machine's risk area

Nobody is permitted to be within the machine's risk area when work is underway.

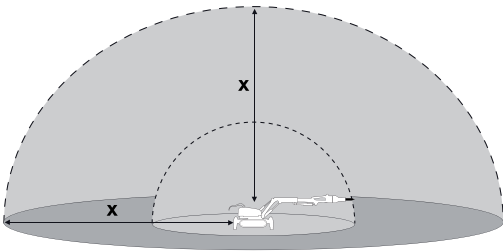

The working area is limited by the machine's reach, however, the risk area varies depending on working method, work object, surface etc. Study possible risks before starting work. If conditions change during the course of the work, the risk area must be redefined.

Workplace

- Define and cordon off the risk area. Nobody is permitted to be within the machine's risk area when work is underway.
- Ensure that the working area is sufficiently illuminated to create a safe working environment.
- The machine can be remote controlled over long distances. Do not operate the machine unless you have clear supervision of the machine and its risk area.
- Never start working with the machine until the working area has been cleared of obstacles.
- Be on the alert when working in environments where there is a substantial risk of slipping due to unevenness, loose material, oil, ice or suchlike.
- Inspect ground conditions, load-bearing structures etc. to prevent materials, machines and staff falling and deal with any risks there might be before starting work.

- When working at a height, for instance on roofs, platforms and the like, increase the size of the risk area. Define and cordon off the risk area at ground level and ensure that no material can fall down and cause injury.
- Ensure when cutting that no material can become loose and fall, causing operating injury. Take great care when working on sloping ground.
- Do not use the machine in environments where there is a risk of explosion. Take the risk of spark formation into account when working in flammable environments.
- Always check and mark where electricity cables and pipelines are routed.
- The air in confined spaces can rapidly become harmful to health due to, for example, dust and gases. Use protective equipment and ensure that there is satisfactory ventilation.

Electrical safety

- Check that the main voltage corresponds with the machine's rating plate.
- The machine must be connected to a functioning protective earth.
- Check all cables and connections. Damaged electric cables can impede the machine's function and lead to personal injuries. Do not use damaged connectors or cables.
- The electric cabinet must not be opened when the machine is connected to power. Some components in the electric cabinet are permanently live, even if the machine is turned off.
- Always connect the machine through an earth-fault breaker with personal protection, i.e. an earth fault circuit breaker that trips at an earth fault of 30 mA.
- The machine must never be driven to such a depth in water that it reaches up to the machine's equipment. The equipment can be damaged and the machine can be live, resulting in personal injuries.
- Ensure that the power cable cannot be run over. Take particular care when moving or when the outriggers are being retracted or extended. Risk of electric shock.
- To avoid overheating do not use an electric cable while it is coiled.
- Always de-energize the machine when carrying out maintenance work and when it is not in use. Disconnect the power cable and place it so that it cannot be connected by mistake.

SAFETY INSTRUCTIONS

Personal safety

- Never use the machine if you are tired, if you have consumed alcohol, or if you are taking other drugs or medication that can affect your vision, judgement or co-ordination.
- Wear personal protective equipment. See instructions under the heading "Personal protective equipment".
- Chemicals such as degreasing agent, grease and hydraulic fluid can give rise to allergies in conjunction with repeated skin contact. Avoid contact with the skin and use protective equipment.
- When in use, the machine can generate dust and fumes that can contain harmful chemicals. Know the nature of the material being worked on and wear appropriate dust mask or respirator protection.

A face mask is especially important when working indoors due to the limited ventilation. In some situations it can also be suitable to apply water in order to decrease the dust.

- Do not stand on the control cable or the power cable as there is a risk of your feet becoming tangled.
- Do not use remote control with cable steering while working or moving where there is a risk that the machine can topple. The operator must be disengaged from the machine.
- An incorrect maneuver or unforeseeable incident can result in collapse. Never stand underneath the work object.
- Never stand where there is a risk of being crushed. The machine can rapidly change position. Never stand underneath a raised arm, even if the machine is turned off.
- Reduce the risk when working alone by making sure that an emergency alarm is available via mobile phone or other equipment.
- When moving on a flat surface you must always walk behind or at the side of the machine. When working or moving on a sloping surface position yourself above the machine.

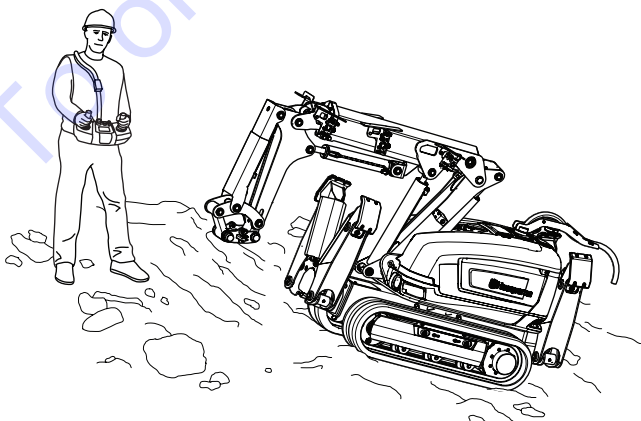

Operation

General

- Only authorized and trained operators are permitted to operate the machine and its tools.
- Never use a defective machine. Carry out inspections, maintenance and service in accordance with the instructions in the Operator's Manual.
- Rectify any faults or damage that occur immediately. Prevent the machine from being used before the fault has been rectified.
- The machine has been tested and approved solely with equipment supplied and recommended by the manufacturer.
- Under no circumstances should you modify the original design of the machine without approval from the manufacturer. Always use original spare parts. Unauthorized modifications and/or accessories may lead to serious injury or death to the user or others.
- Do not modify the machine's safety devices and check regularly that they are working properly. The machine must not be driven if protective plates, protective covers, safety switches or other protective devices are not fitted or are defective.
- Make sure all nuts and bolts are tightened correctly.
- The machine must be kept clean. Signs and stickers must be fully legible.
- Follow the machine's and the tool's instructions carefully when changing tools in order to avoid injuries.
- Turn off the electricity supply to the machine before you take off the remote control or when you leave the machine to avoid the risk of unintentional operation.
- Firm handling of the joysticks does not make the machine stronger or faster. On the contrary, the joysticks can buckle with unnecessary repairs as a consequence.
- Do not lift the remote control by the joysticks.

Education and training

- New operators must be trained by experienced operators with the capacity to use sound judgment when supervising the work.
- Practice stopping the machine and locating the stop button quickly. Practice maneuvering in different directions, on a slope and different surfaces.
- Test the machine's stability under controlled conditions. Practice rapid evacuation.
- On completion of the training, the operator should be properly acquainted with the machine's limitations with respect to reach, capacity and stability, and also be able to maneuver the machine safely.

SAFETY INSTRUCTIONS

Maneuvering

General

- If several machines are used at the same workplace there is a risk of mixing up the remote controls. Switch on the current to the remote control and the machine. Press the horn to see which machine is connected to the remote control. The machine will beep and flash three times. Do not activate the remote control before you have ensured that the correct machine is being operated.
- Wait until the remote control has been turned off and the motor has stopped before you enter into the machine's risk area.
- Never leave the machine unsupervised with the motor running.
- The machine can overturn during work. During operation the machine must be positioned as level as possible and the outriggers must be fully extended.
- In some cases it can be difficult to determine which end of the machine is the front and which is the rear. Look at the direction markings on the sides of the machine's tracks to avoid incorrect operation.

Outriggers

- When the outriggers are folded, the arm must be retracted to minimize the risk of the machine overturning.
- The machine's outriggers can leave the ground, especially when working with a hydraulic hammer or bucket. The higher the machine rises the greater the load the rest of the support mechanism is subject to.
- When working with a hydraulic hammer there is an increased risk of the machine tipping or landing with a large force on the outrigger on impact. Take this risk into account and institute appropriate safety measures to avoid any personal injury or mechanical damage.

Rotation function

- If there is a breakdown in the machine's rotation mechanism the machine's upper part may rotate freely, potentially causing personal injury or mechanical damage. Keep your distance.
- The machine is most stable when working directly forwards or backwards. When the machine's upper part rotates to the side, the outriggers should be down and the arm system maneuvered so that it is as close to the ground as possible.
- In some cases it can be difficult to predict the direction of rotation. Operate the turning motion carefully until you have apprehended the direction of rotation.

Arm system

- Do not use the arm system and the rotation function for striking, demolishing or scraping.
- Do not work with the arm if the machine's outriggers are folded. The outriggers provide stability and reduce the risk of the machine tipping.
- When the arm system's reach is being used, the load increases as does the risk of tipping. Position the machine as close to the working object as possible.
- Never use the telescopic arm to press the tool against the working object.
- Do not secure the machine to fixed objects, e.g. walls, to increase the force on the working object. Both the machine and the tool can be subject to overloading.

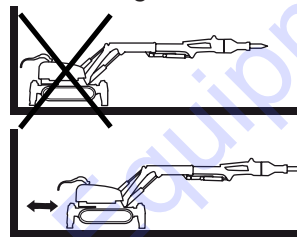

- Do not work with the machine's cylinders in the inner or outer end positions to avoid overloading. Leave a few centimeters to the maximum position. The hydraulic fluid then has a greater capacity to alleviate impacts and vibrations.
- There are two working positions that put a lot of strain on individual cylinders.

Cylinders 1 and 2 are in their outer positions and the hammer is working in the upward direction. Never operate the cylinders to their end positions.

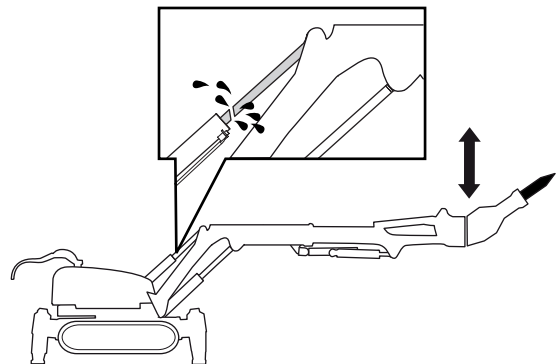

Cylinder 3 is in its outer position and the hammer is working in the downward direction. Never operate the cylinders to their end positions.

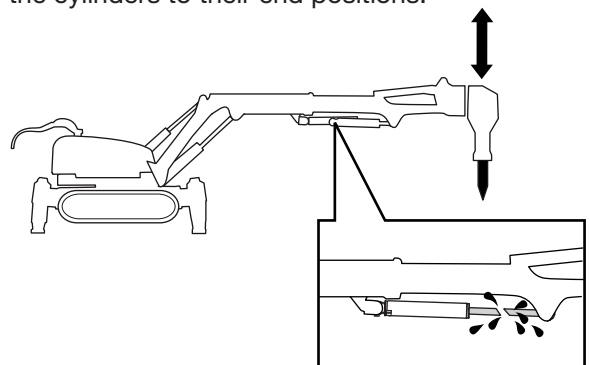

SAFETY INSTRUCTIONS

Proximity to edges

- Inadequate surfaces, incorrect operation, etc. can cause the machine to slide. Exercise particular caution when working close to shafts, beside trenches or when working at height.
- Always anchor the machine and loose tools when working close to edges.
- Ensure that the machine is stable and does not move closer to the edge while work is in progress.
- Ensure that the underlying surface has satisfactory bearing capacity. Vibrations affect bearing capacity.

Uneven surfaces

- Extend the outriggers so that they are positioned just above the surface when moving over uneven areas.
- In some cases the arm can be used to lift the drive gear over bumps. The arm must never be rotated or raised up high due to the risk of overturning.
- Uneven surfaces can cause the machine to lean to such an extent that it overturns. Maneuver the machine's arm system inwards in order to move the center of gravity as close to the machine's center as possible to reduce the risk of tipping.
- Surfaces with a poor bearing capacity can cause the machine to change direction or even overturn without warning. Always check the bearing capacity and properties of the surface before starting the machine. Also be alert for holes that are covered by materials with a poor bearing capacity.
- The machine's caterpillar tracks produce a low level of friction against smooth surfaces. Water, dust and contaminants can further reduce friction. When defining the risk area you should take into account the fact that less friction increases the risk of the machine starting to slide.

Confined spaces

- Working in confined spaces with extended outriggers can be difficult. The machine's stability is considerably diminished. Adapt the work accordingly. There is an increased risk of the machine overturning if the arm swings outside the outrigger.
- When moving in confined spaces it is possible to reduce the width of the tracks, increasing the risk of the machine overturning. There is an increased risk of the machine overturning if the arm swings outside the outrigger.

Sloping ground

- Sloping surfaces, stairs, ramps etc. can constitute major risks when moving and working. With gradients in excess of 35° there is a risk of the machine tipping.
- The machine's arm system and outriggers must be positioned as low as possible to reduce the risk of tipping.
- Do not run the caterpillar tracks and tower simultaneously when moving on a sloping surface to reduce the risk of unexpected motion.
- Avoid driving sideways on slopes - drive straight up or down. Ensure that the machine's arm system is turned upwards in sloping terrain.
- Always position yourself above the machine when driving on a slope. There is a risk of the machine tipping.
- Anchor the machine if there is a risk of the machine starting to move.
- Check that there is sufficient bearing capacity when driving on ramps and stairs.

Proximity to ducts and pipes

- Always check and mark where electricity cables and pipelines are routed. Ensure that electricity cables and pipelines are shut off.
- The machine must not get close to overhead cables. The current can "jump" over long distances.

Falling material

- Watch out for demolition material becoming loose when cutting. Use personal safety equipment and keep your distance.
- Ensure that the vibrations from the hydraulic hammer do not cause cracks to form or stones or other material to loosen and cause personal injury or damage to property. Keep your distance!

SAFETY INSTRUCTIONS

Transport and storage

Lifting the machine

- When lifting the machine there is a risk of injuring persons or damaging the machine or the surroundings. Define the risk area and check that nobody is present within the area when lifting.
- Use an approved lifting device to secure and lift heavy machine parts. Also ensure that there is equipment to secure machine parts mechanically.
- Retract the arm system. The center of gravity must be as close to the machine's center as possible.
- The lifting equipment must be attached at all the machine's lifting eye bolts.

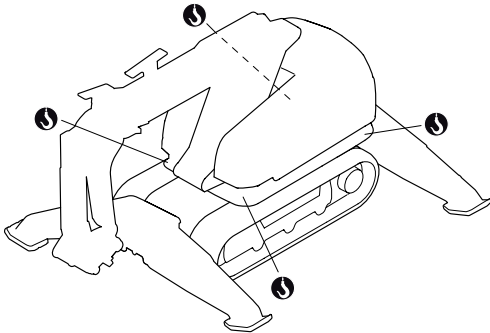

- Lift slowly and carefully. Make sure that the lift is in equilibrium and if the machine starts to lean, rectify it by using an alternative lifting device or change the position of the arm system.
- Ensure that the machine's parts are not crushed or damaged when lifting and that the machine does not hit surrounding objects.

Loading and unloading using a ramp

- Ensure that the ramp is intact and the right size for the machine.
- Check that the ramp is free of oil, mud or anything else that might make it slippery.
- Ensure that the ramp is properly secured to both the vehicle and the ground. The vehicle being used for transportation must also be secured so that it cannot move.

Transport

- The machine may only be transported on a flatbed truck or a trailer that is approved for the machine's weight, refer to the machine's rating plate. The remote control must be properly protected in the vehicle during transportation.
- Check applicable road traffic regulations before transporting on public roads.

The machine's position on the loading platform

- Position the machine against the front edge of the platform in order to reduce the risk of it sliding forward if the vehicle brakes.
- Maneuver the arm system so that it is resting against the platform, positioned as low as possible. Extend the outriggers without lifting the machine.

Securing the machine

- Secure the machine with approved tightening straps. Use the machine's lifting eye bolts. Ensure that no part of the machine are squashed or damaged by the tightening straps. It is a good idea to cover the machine.

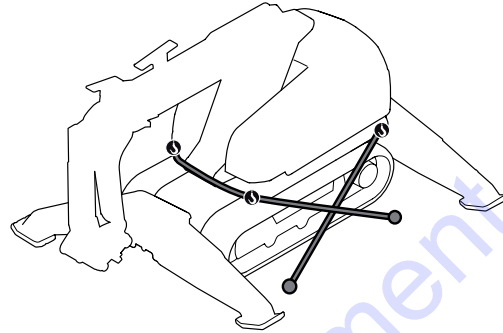

- Tools and other equipment must be secured with separate tightening straps.
- Regularly check that the load is secure during transportation.

Storage

- Remove the tool from the machine.
- Retract the arm system to attain a center of gravity that is as low as possible and to save space.
- Store the equipment in a lockable area so that it is out of reach of children and unauthorized persons.
- Store the machine and its equipment in a dry and frost proof place.

Towing

The machine is not designed to be towed. When the machine is depressurized, the drive motor's parking brakes are activated and the caterpillar tracks cannot rotate. Only tow the machine if its position constitutes a risk and there is no other solution. Tow it for the shortest possible distance.

- If possible, retract the outriggers before towing the machine in order to reduce the risk of them getting stuck and being damaged.
- To minimize the load on the towing device and mechanical components, reduce the friction by preparing the route that the machine is going to be towed.
- If possible tow in the direction of the tracks.
- Use the lifting eye bolts to connect to the towing device. Use a towing device intended for the particular load.
- Parts can loosen during towing. Keep your distance!

SAFETY INSTRUCTIONS

Maintenance and service

Most accidents involving machines occur during trouble shooting, service and maintenance as staff have to locate themselves within the machine's risk area. Prevent accidents by being alert and by planning and preparing the work. You can also refer to 'Preparations for maintenance and service' in the 'Maintenance and service' section.

- The user must only carry out the maintenance and service work described in this Operator's Manual. More extensive work must be carried out by an authorized service workshop.
- Never carry out repairs without having the necessary expertise.
- Only trained service personnel are permitted to intervene in the electrical or hydraulic systems.
- Use personal protective equipment as well as equipment to mechanically secure machine components during maintenance and service.
- Set out clear signs to inform persons in the vicinity that maintenance work is in progress.
- If service operations or trouble shooting does not require the machine to be switched on, the power cable must be removed and positioned so that it cannot be connected by mistake.
- Ensure there is no current to the machine by removing the power cable before opening or removing the electric cabinet or any other component that contains electrical current.
- Pipe and hose couplings can remain pressurized despite the motor being switched off and the power cable disconnected. It must always be assumed that hydraulic hoses are pressurized and they must be opened with great care. Relieve the pressure on the arm system by resting it on the ground and turn off the electric motor before undoing the hoses.
- Never try to stop hydraulic fluid leaking from a broken hose by hand. Finely dispersed hydraulic fluid at high pressure can permeate under the skin and cause very severe injuries.
- When dismantling machine parts, heavy components can start moving or fall down. Secure moving parts mechanically before loosening screw joints or hydraulic hoses.
- Use an approved lifting device to secure and lift heavy machine parts.
- Several components heat up during work with the machine. Do not commence any servicing or maintenance tasks until the machine has cooled.
- Keep work area clean and well lit. Cluttered or dark areas invite accidents.
- The machine's movements can be defective if a terminal, cable or hose is incorrectly assembled. Exercise caution during test runs and be prepared to turn off the machine immediately in the event of a fault.

The machine's safety features

The machine's safety features can be divided into safety features for personal protection and those for mechanical protection. Some of the safety features provide both mechanical and personal protection.



WARNING!

Do not modify the machine's safety devices and check regularly that they are working properly. The machine must not be driven if protective plates, protective covers, safety switches or other protective devices are not fitted or are defective.

Personal protection

Indication of zero position

If either of the joysticks is in an operative position when the remote control is started, the function will be blocked. The operator is informed of this by means of an error message appearing on the screen. To reset the function, the remote control must be turned off and on again.

The function also protects against faults in the potentiometer or cable breaks.

Signal voltage limitation

Signal voltage limitation prevents the machine executing unexpected movements in the event of a cable breaking or a short-circuit.

The voltage level of the control signals is limited to within a maximum and minimum value. If the voltage level falls outside the permitted interval, the machine stops.

Joystick guard

The safety feature reduces the risk of unintentionally moving the machine by locking the control circuit if the joysticks have been in neutral for three seconds.

The control circuit is activated by means of the left button on the right joystick. It is activated when the button is released. This guards against fixing the button in an active position.

Radio block

If the remote control has been turned off for two minutes the electronic unit in the machine is blocked to radio signals. It is not possible to restart the machine until the supply voltage to the machine has been turned off and on again.

The safety feature ensures that the operator knows which machine will start and that the correct remote control is being used for the machine. This is particularly important when there are several machines at the same workplace.

SAFETY INSTRUCTIONS

Identity code

The remote control and the machine are connected by means of a pre-programmed ID code. The ID code ensures that the right remote control is used for the right machine.

If several machines are used at the same workplace there is a risk of mixing up the remote controls.

Switch on the current to the remote control and the machine. Press the horn to see which machine is connected to the remote control. The machine will beep and flash three times. Do not activate the remote control before you have ensured that the correct machine is being operated.

When steering the machine using cables, the ID code is suppressed and the same remote control can be used for different machines if these have the same control system version.

Automatic frequency hopping

In the event of interference in the communication, the frequency changes automatically to guarantee interference-free transmission.

Emergency stop/machine stop

When the machine stop on the remote control is pressed, the power to the circuits controlling the communication with the machine is interrupted. The machine engine stops due to the interruption of the transfer of signals to the machine's electronic device.

The emergency stop on the machine switches off the main power to the machine.

Protective earth

The machine and its components are connected to grounding conductors in the power cable. If there is a fault, a fuse is tripped and the current is disconnected.

The machine must be connected to a power point with a protective earth. If there are no grounding conductors, or if they are connected incorrectly, have come off or are loose in a terminal, the current will remain connected and touching the machine can be highly dangerous.

If there is reason to believe that the protective earth has been damaged, the machine must be turned off and the power cable removed until such time as the protective earth has been restored.

Always connect the machine through an earth-fault breaker with personal protection, i.e. an earth fault circuit breaker that trips at an earth fault of 30 mA.

Hydraulic brake

Hydraulic motors are used when moving the machine. All hydraulic motors are fitted with brakes. These hydraulic motors contain counter balance valves that prevent uncontrolled flow through the motor, e.g. when maneuvering down a slope or when the machine is parked. The counter balance valve closes the tank opening when the drive motors are not being operated.

Mechanical brake

The machine's drive motors are equipped with a mechanical parking brake. The machine is braked until its drive function is activated.

Mechanical protection

Automatic phase rotation relay

The automatic phase rotation relay prevents the electric motor starting with the wrong rotation direction thus causing mechanical damage.

Motor protection

To prevent overloading, the motor is equipped with bimetallic relays in the motor linings that disconnect the power if the motor gets too hot.

If the motor is too hot it is not possible to operate the tools. The rest of the machine's functions can be run at half speed in order to facilitate evacuation of the machine from risky environments.

Once the motor's temperature has fallen to a normal working temperature all functions can be used again.

The machine's softstarter is fitted with a motor cut-out that trips if the current is too high for too long a period. The machine's functions return to normal position after three minutes.

Fuses

Fuses are used to protect the following components as well as to prevent fire in conjunction with faults or if electrical components are overloaded.

Pressure relief valves

The machine's hydraulic system is equipped with pressure relief valves. They protect the hydraulic system against too high pressure and the mechanical components against overloading.

Pump-around valve

The pump-around valve drains the hydraulic flow into a tank and relieves the pressure on the hydraulic system. No pressure enters the cylinders and it prevents the risk of unforeseen movements. This happens, for example, after three seconds of inactivity.

SAFETY INSTRUCTIONS

External environmental factors

Temperature

The ambient temperature, both heat and cold, affects the machine's operational reliability. Temperature variations also have an impact as they produce an increased risk of condensation forming in the machine's tanks.

Heat

NB! *There is an increased risk of overheating in warm environments. Both the machine's hydraulic system and electronic components can be damaged.*

The maximum working temperature for hydraulic fluid is 90°C (194°F). Overheating results in deposits forming in the fluid, leading to increased wear, damaged seals and leakage. Overheated hydraulic fluid provides poor lubrication, resulting in inferior performance.

To avoid overheating:

- Keep the machine clean, in particular its cooler.
- Ensure that there is good ventilation when working indoors.
- Radiant heat can cause local heating that damages parts of the machine. Screen off vulnerable components.
- Additional cooling is required if there are high ambient temperatures. Supply the machine with forced cooling using compressed air.

To avoid damage to the machine:

- Change hydraulic fluid and filters more frequently.
- Check the machine's seals to prevent dirt in the hydraulic system due to broken seals.
- Rubber caterpillar tracks must not be exposed to temperatures of over 70°C (158°F). In hotter environments steel tracks have to be used.

Cold

Do not use maximum pump pressure if the hydraulic fluid is less than 10°C (50°F). Allow the machine to warm up slowly. Warm up the lower section by running the caterpillar tracks, first slowly and then more quickly with the outriggers extended. Move the upper section back and forth and operate all cylinders in the arm system without load. The machine is ready for use when its temperature has risen to around 40°C (104°F).

Moisture

When working in damp environments the operator should ensure that electrical components, connectors for example, are not submerged in water.

The machine must never be driven to such a depth in water that it reaches up to the machine's equipment. The equipment can be damaged and the machine can be live, resulting in personal injuries.

Dust and particles

Dust and particles can block the machine's cooler, cause overheating and increase wear on the machine's bearings and shafts. Clean and lubricate the machine regularly.

The hydraulic system is extremely sensitive to contaminants. Small particles can cause breakdowns and increase wear in the components.

There is a high risk of contamination in conjunction with servicing and repairs when the hydraulic system is opened.

Contamination of the hydraulic system can be prevented by:

- Keeping the machine clean, particularly before servicing, repairs or changing tools.
- Carrying out daily inspections.
- Carrying out regular servicing.

The machine's functions

The machine's functions are operated by means of interaction between the hydraulic system, the electric system and the control system.

A brief description of the machine's functions follows below.

Arm system

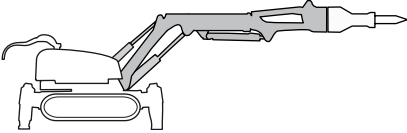

The arm system is divided into three parts in order to provide extensive movement, a long reach and compactness. Expanding shafts minimize the risk of play in the joints.

By running cylinder 1 and cylinder 2 in parallel, the machine's reach can be modified without moving the machine.

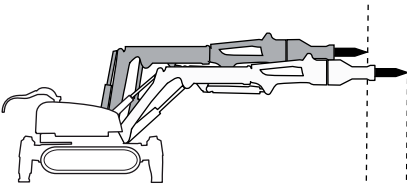

The machine is also equipped with a telescopic arm that provides additional reach. Work as close to the work object as possible as this makes optimum use of the power to the arm system and cylinders.

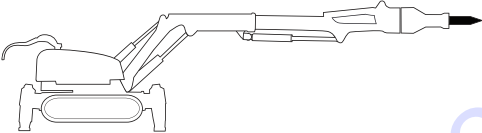

Tower

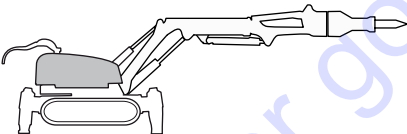

The tower has unlimited rotation, which means that it is possible to work in several directions without having to move the machine. The machine is equipped with a slew brake. When the rotating function is not activated, the function is braked by means of passive brakes.

NB! The machine's rotating function must not be subject to overload, e.g. caused by tools that exceed the weight limit.

Caterpillar tracks

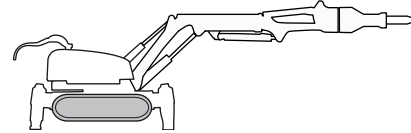

The caterpillar tracks are driven individually by hydraulic motors. The machine can be turned by operating the caterpillar tracks at different speeds. Operating the tracks in different directions enables the machine to make tight maneuvers. When the drive function is not activated the passive brakes lock the drive motors.

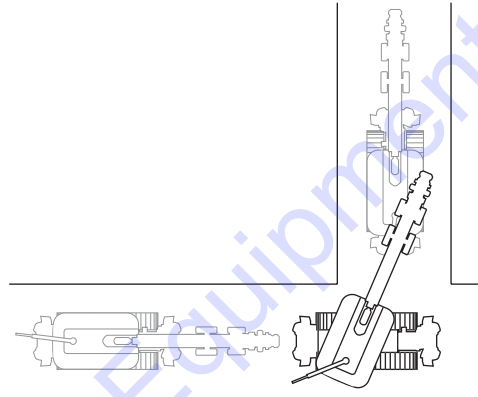

In transport mode, the caterpillar tracks and tower can be maneuvered simultaneously. The function can be used, for example, when the machine is being operated in confined spaces.

Outriggers

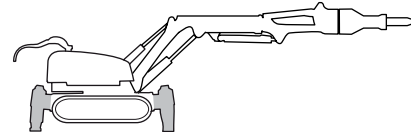

The main function of the outriggers is to give the machine stability. They must always be used when working with the machine.

Tools

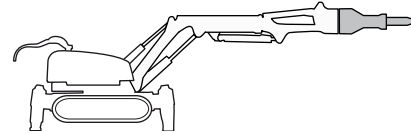

The machine should be fitted with tools that are appropriate for the tasks that are to be carried out. The weight and performance requirement of the tool is decisive in ascertaining whether it is suitable for use with the machine. Further information is available in the 'Tools' and 'Technical data' chapters and the tool supplier's instructions.

External tool (optional)

The machine has been prepared with connections for external hand tools for the machine's hydraulic system.

PRESENTATION

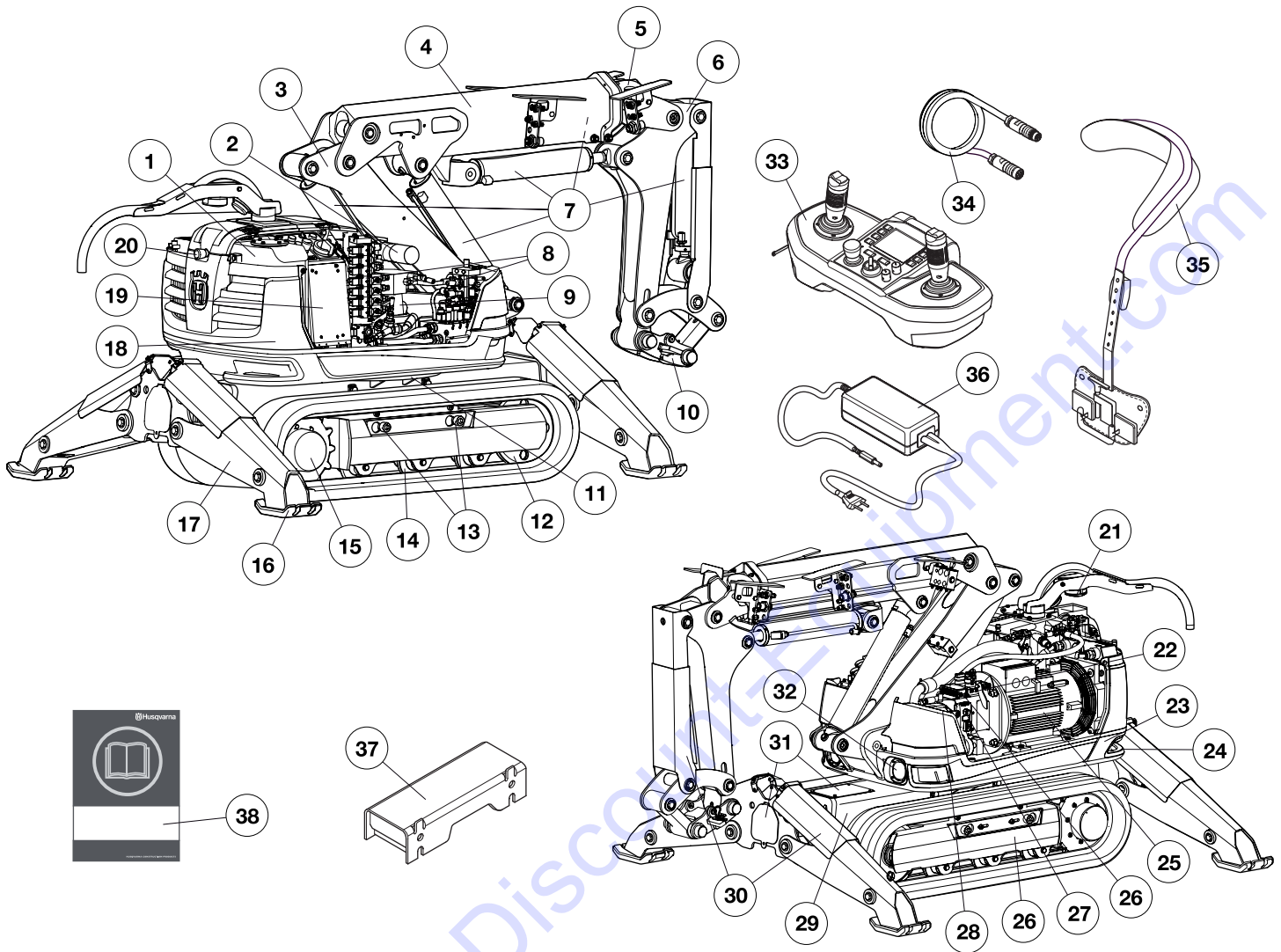

What is what in the machine

- | | |
|--|---|
| <ul style="list-style-type: none"> 1. Hydraulic tank 2. Lubrication pump for lubricating the hammer (accessory) 3. Arm 1 4. Arm 2 5. Telescopic arm 6. Arm 3 7. Cylinders 8. Valve block 9. Slew motor 10. Tool attachment 11. Gear ring 12. Tensioning wheel 13. Screws for widening the tracks 14. Support wheel 15. Drive motor 16. Outrigger foot 17. Outrigger 18. Counterweight in the tower 19. Electric cabinet | <ul style="list-style-type: none"> 20. Emergency stop 21. Warning light 22. Control module 23. Base plate 24. Lifting eye bolts 25. Electric motor 26. Radio module 27. Track unit 28. Hydraulic pump 29. Chassis beam 30. Cylinder guard 31. Inspection covers 32. Work lighting 33. Remote control 34. Communication cable 35. Harness 36. Battery charger 37. Track widener 38. Operator's Manual |
|--|---|

General

The task of the hydraulic system is to operate the machine's functions by means of hydraulic pressure and flow. The system consists of hydraulic pump, tank, cooler, hydraulic motor, hydraulic cylinders, filters and valves of various kinds. Hoses or pipes connect the components with each other.

Valves are used to control the hydraulic system's pressure, volume rate of flow and direction. Pressure control valves limit or reduce the pressure to the value required. Volume control valves affect the hydraulic fluid's flow and thereby the speed of the functions. Direction control valves direct the hydraulic fluid to the machine's different functions.

The hydraulic pump is of the variable displacement type and delivers a flow of 0-65 l/min (0-17 gal/min).

Main pressure

The hydraulic system has two main pressures.

- Standard pressure is 200 Bar.
- Increased main pressure is 250 Bar.

Increased main pressure is used when the outriggers are down and when concrete cutters are used with increased tool pressure.

If concrete cutters with increased tool pressure are operated at the same time as another function, the machine returns to standard pressure.

Pressure cut-off

Functions equipped with pressure cut-off have a reduced pre-set maximum pressure. The telescopic arm is equipped with a pressure cut-off that produces a maximum of 180 Bar.

Cooler

The cooler has an integrated bypass valve that protects against overpressure in conjunction with, for example, cold start.

HYDRAULIC SYSTEM

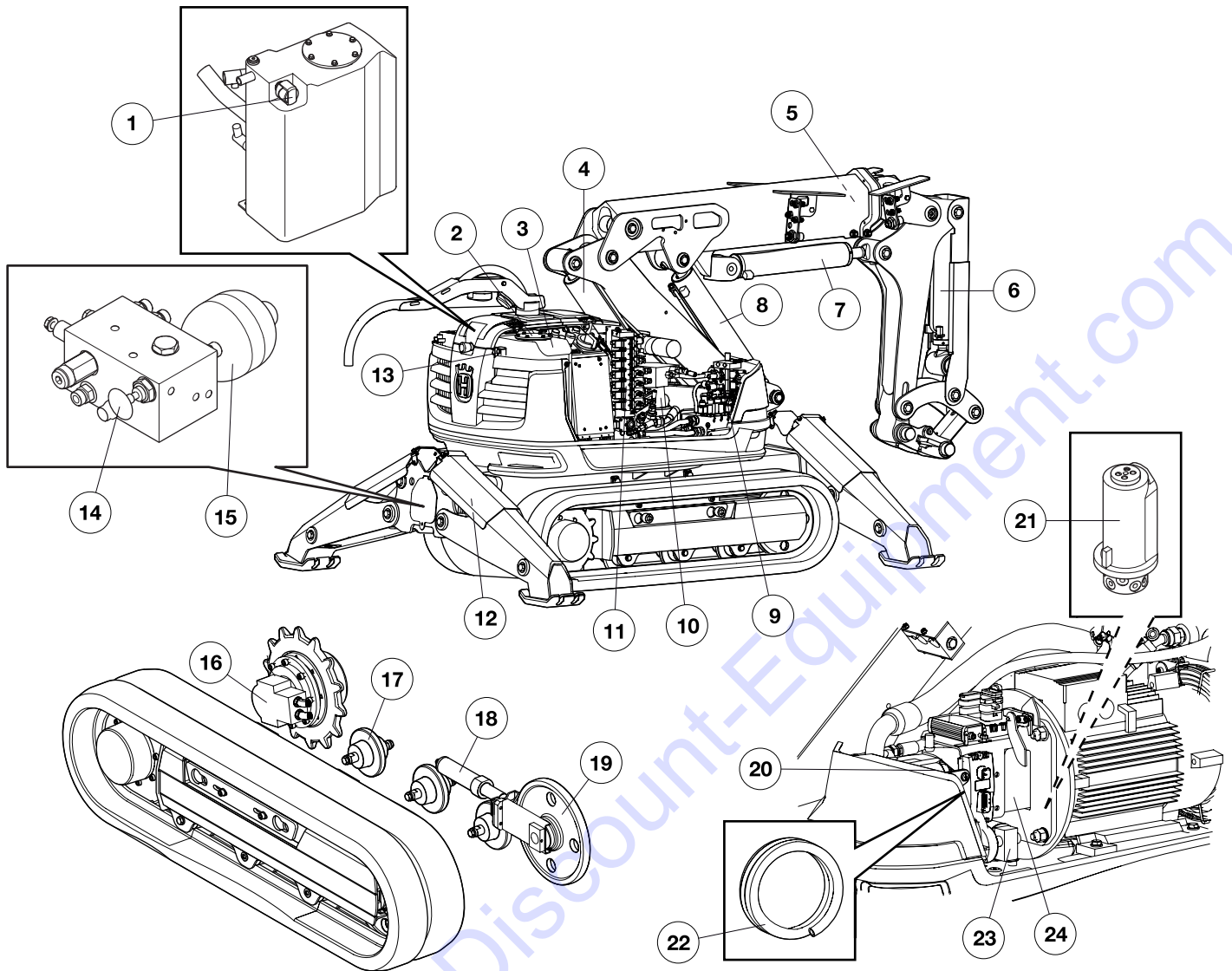

The machine's hydraulic system

- | | |
|-----------------------------------|------------------------------------|
| 1. Air filter | 15. Accumulator - track tension |
| 2. Oil filter | 16. Drive motor, drive gear |
| 3. Hydraulic tank | 17. Support wheels |
| 4. Cylinder 1 | 18. Cylinders for track tensioning |
| 5. Cylinder 5 | 19. Tensioning wheel |
| 6. Cylinder 4 | 20. Hydraulic pump |
| 7. Cylinder 3 | 21. Swivel |
| 8. Cylinder 2 | 22. Hose for oil filling |
| 9. Valve block 1 | 23. Filling pump |
| 10. Slew motor | 24. Intermediate piece |
| 11. Valve block 2 | |
| 12. Cylinders for outriggers | |
| 13. Sight gauge | |
| 14. Valve - release track tension | |

General

The electric system consists of a high-voltage circuit and a low-voltage circuit.

High-voltage circuit

High-voltage is used as a power source for both the electric motor and the low-voltage circuit. An automatic phase rotation change-over switch ensures that the electric motor has the correct rotation direction.

Power supply

The power supply from the main must be sufficiently powerful and constant to ensure that the electric motor runs without problems.

Too high or too low voltage causes the electric motor's power consumption, and consequently also its temperature, to increase until the motor's safety circuit trips.

Fuses

The fuses in the distribution box protect the electrical system in conjunction with overloading or breakdown. The power outlet must be correctly fused with respect to the electric motor, the length of the power cable and the area of the power cable's conductor. The table "Guide values for mains connection" in the "Technical data" section shows which fuse is required for the electric motor.

The machine is equipped with Softstart and can be started with most types of fuses.

If a fuse keeps blowing there is a fault in the electrical system or in the machine that is connected to it. Before restarting the machine the source of the fault must be removed.

Power cable

The machine is connected to the mains with a 3 phase power cable. It is very important that the cable that is used is correctly dimensioned, i.e. that it has the correct cross-sectional area in relation to the length of the conductor in order to counteract drops in voltage. The guide values for the cable's size are set out in the table 'Guide values for main connection' in the 'Technical data' section.

Low-voltage circuit

The high-voltage current is reduced to low-voltage in an AC/DC module. It is used to supply power to the control system and functions such as work lighting and refilling pump.

ELECTRIC SYSTEM

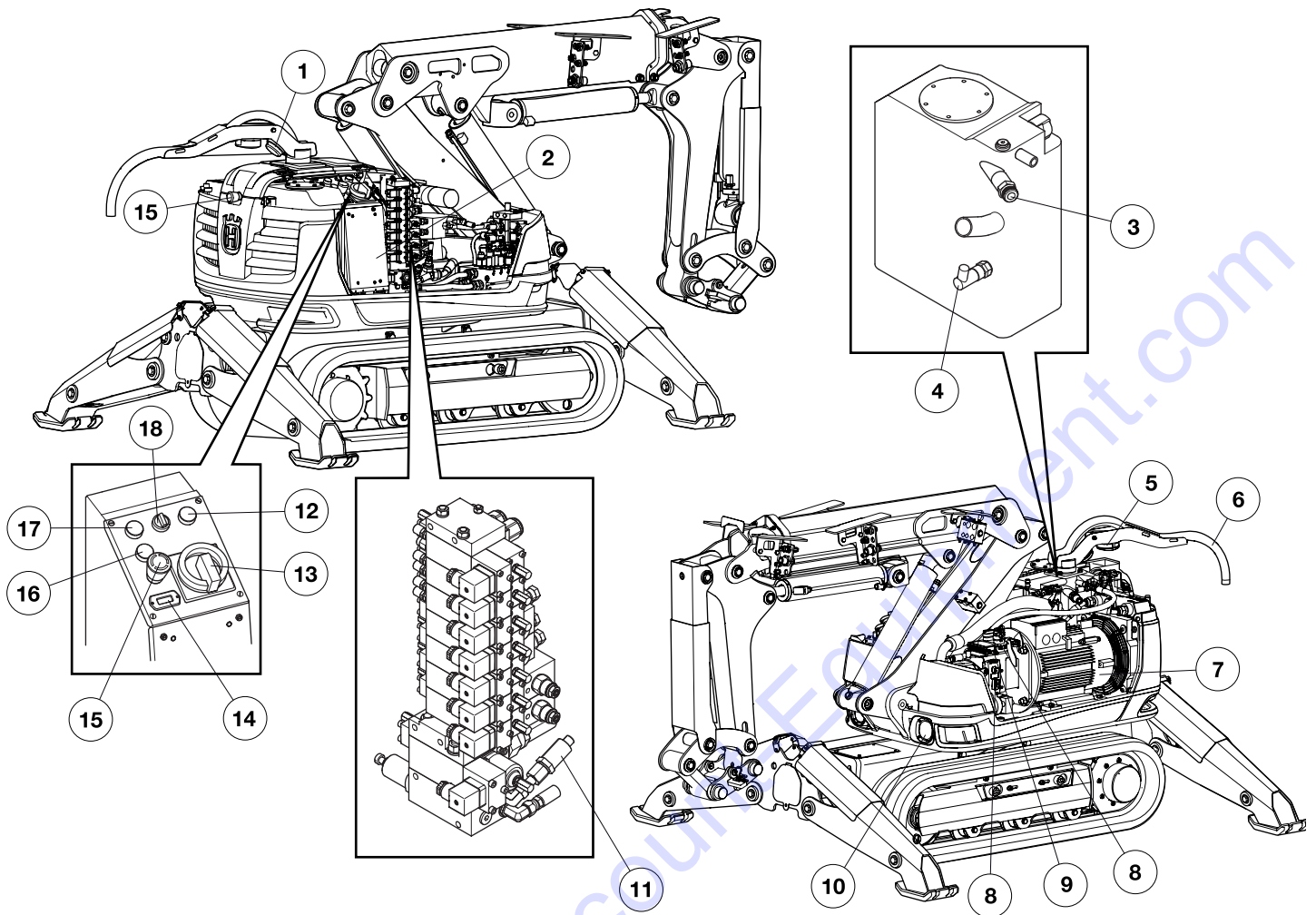

The machine's electric system

1. Aerial
2. Electric cabinet
3. Pressure switch
4. Temperature sensor
5. Warning light
6. Power cable
7. Electric motor
8. Control module
9. Radio module
10. Work lighting
11. Pressure sensor
12. External tool
13. Main switch
14. Counter
15. Emergency stop
16. Automatic oil refilling
17. Start button motor
18. Knob for remote control/emergency operating mode

General

The remote control, the electronics unit and the pilot control valves are the main components in the control system. The signals from the remote control are transmitted to the machine via bluetooth or via a cable. The electronic unit in the machine transmits the signals via the pilot control valves to the hydraulic system by converting electric current into hydraulic pressure.

Remote control

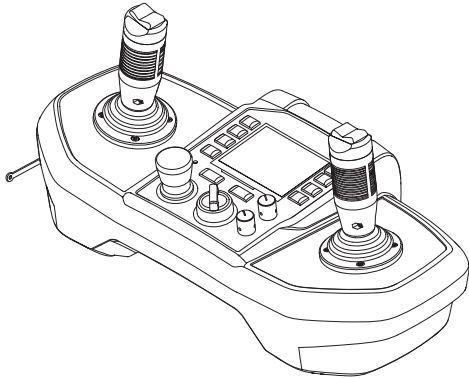

The machine is controlled from the remote control. Transmission of signals is either wireless, using bluetooth, or via a cable.

The movement of the joysticks is proportional. A small movement means that the function moves slowly, a larger movement increases the function's speed proportionally.

Signal transmission

Identity code

The remote control and the machine are connected by means of a pre-programmed ID-code. The code is built into the remote control's bluetooth transmitter and the receiver on the machine. The ID code cannot be changed.

There is a sticker on the bottom of the remote control and on the machine's bluetooth module with a ID code. The ID code ensures that the right remote control is used for the right machine.

Wireless signal transmission

Wireless transmission of signals uses bluetooth technology.

Automatic frequency hopping

In the event of interference in the communication, the frequency changes automatically to guarantee interference-free transmission.

Signal transmission using cables

Connecting a cable shuts off the wireless communication.

When the machine is controlled by means of cables, the ID code is suppressed and the same remote control can be used for different machines if these have the same control system version.

Battery

The battery is a Li-ion type. Operating time is about 8-10 hours per charge. Extreme cold impairs the battery's capacity and operating time. Operating time is also affected by the extent to which the display has been active.

To save the battery, the display goes into energy save mode after 20 seconds. After five minutes of inactivity the remote control turns off automatically. To use it again, it must be turned off and on again.

A message appears on the display approx. 30 minutes before the battery is completely flat. It is not possible to activate the remote control if the battery capacity is too low.

Charging the battery

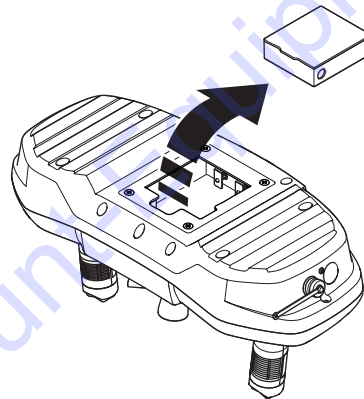

Before using the remote control for the first time the battery has to be charged.

Charging time for a flat battery is approx. 2-3 hours. The diode is orange when charging starts and becomes green when the battery is fully charged. When the battery is fully charged the charger supplies the battery with maintenance current until the battery is removed from the charger.

Keep the battery charger dry and protected against temperature fluctuations.

CONTROL SYSTEM

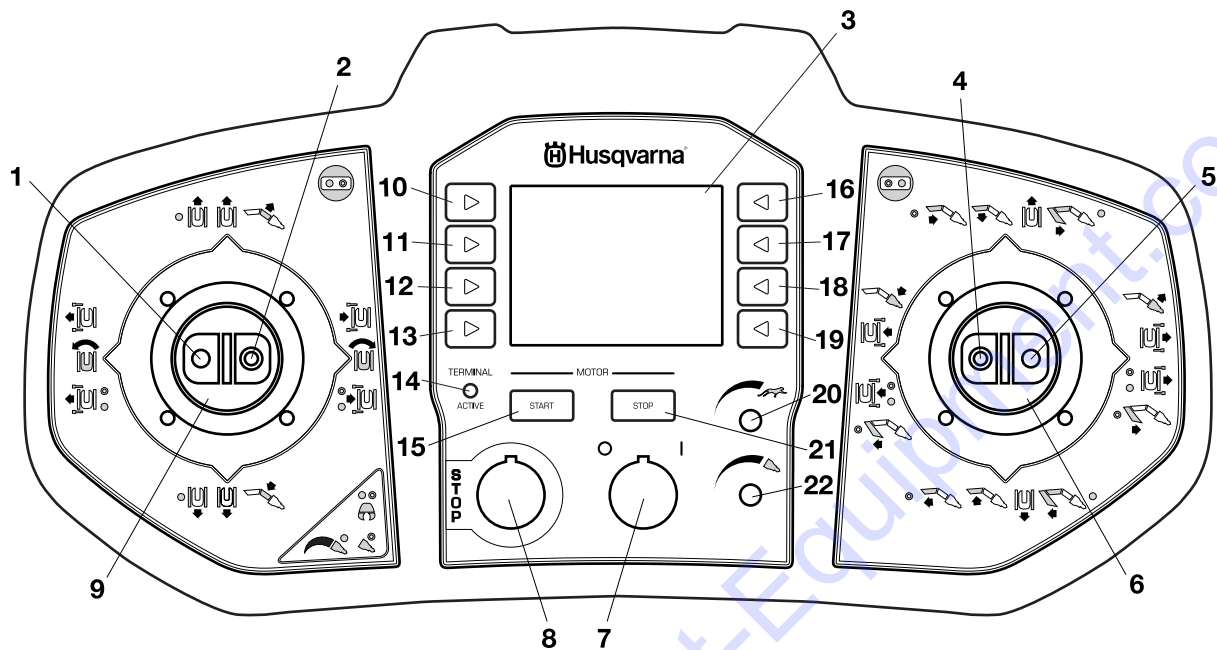

What is what on the remote control

- 1. Left joystick - left button
- 2. Left joystick - right button
- 3. Display
- 4. Right joystick - left button
- 5. Right joystick - right button
- 6. Right joystick
- 7. Main switch
- 8. Machine stop
- 9. Left joystick
- 10-13. Menu buttons
- 14. Light emitting diode, joysticks active
- 15. Start button motor
- 16-19. Menu buttons
- 20. Flow to machine movement/speed
- 21. Stop button motor
- 22. Flow to hydraulic tool

CONTROL SYSTEM

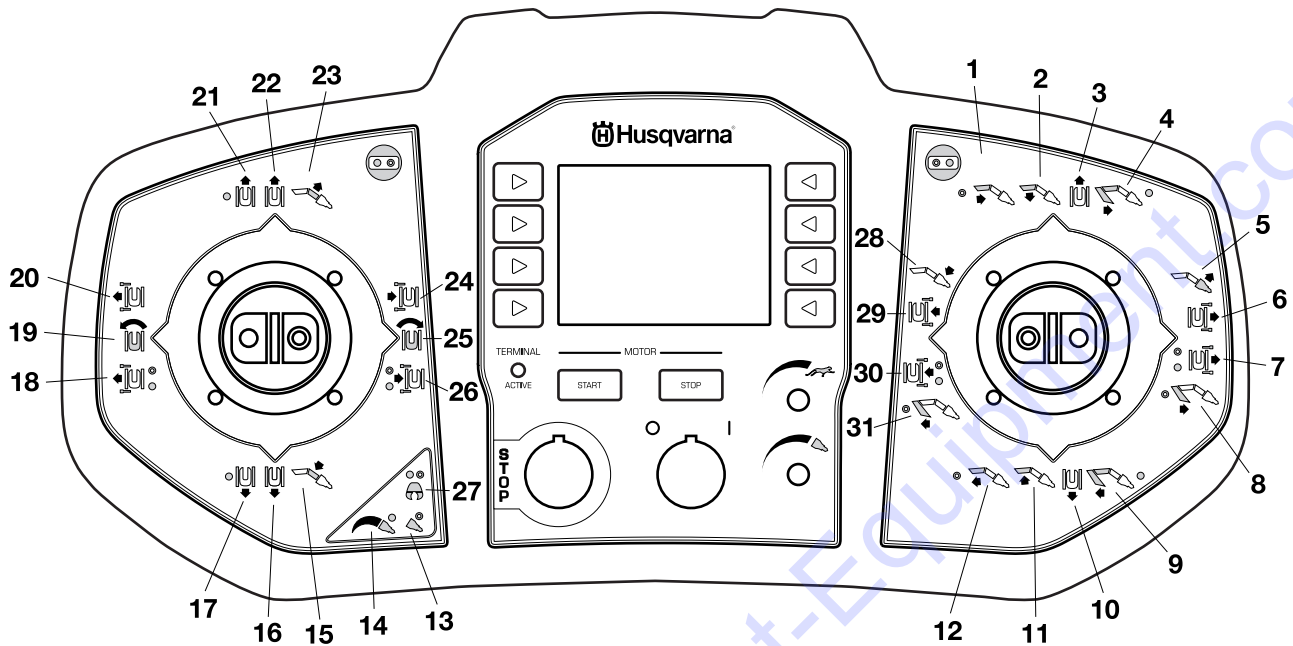

Symbols on the remote control

- | | |
|--|--|
| <ul style="list-style-type: none"> 1. Arm 2 telescope out 2. Arm 2 down 3. Right track operation forward 4. Arm 1 and arm 2 out 5. Angle tool outwards 6. Right outrigger down 7. Front/rear right outrigger down 8. Arm 1 out 9. Arm 1 and arm 2 in 10. Right track operation backwards 11. Arm 2 up 12. Arm 2 telescope in 13. Sticker - full flow to the tool 14. Sticker - adjustable flow to the tool 15. Arm 3 down | <ul style="list-style-type: none"> 16. Left track operation backwards 17. Caterpillar tracks backwards 18. Rear/front left outrigger down 19. Rotation tower anti-clockwise 20. Left outrigger down 21. Caterpillar tracks forward 22. Left track operation forward 23. Arm 3 up 24. Left outrigger up 25. Rotation tower clockwise 26. Rear/front left outrigger up 27. Sticker - open/close cutters 28. Angle tool inwards 29. Right outrigger up 30. Front/rear right outrigger up 31. Arm 1 in |
|--|--|

STARTING AND STOPPING

Before starting

The following points should be checked when working at a new site and every morning before starting:

- Carrying out daily inspections.
- Examine the machine for transport damage.
- Check that the machine's safety features are intact. Refer to 'The machine's safety features' in the 'General working instructions' chapter.
- Check that the power cable and operating cables are intact and correctly dimensioned.
- Check that the mains voltage is compatible with the machine and that the correct fuses are used.
- Always connect the machine through an earth-fault breaker with personal protection, i.e. an earth fault circuit breaker that trips at an earth fault of 30 mA.
- Check that the emergency stop or machine stop button are not pressed by turning them clockwise.
- Check that no tools or other objects have been left lying on the machine.

Starting

Connect the machine

- Connect the machine to a 3 phase power supply.
- Turn on the main switch on the machine.

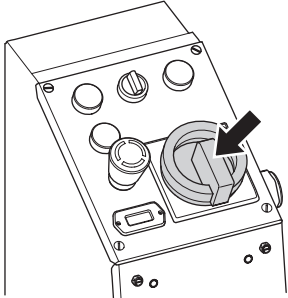

Starting the remote control

- Turn the switch to the ON position (I). In this position the remote control is supplied with current. The light emitting diode on the remote control flashes rapidly with a blue light when it is searching for contact. When it flashes with a longer interval the machine is in standby mode.

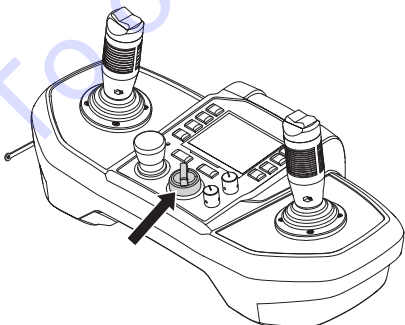

- If a function is not working or needs attention, an error message appears on the display in conjunction with start-up. Refer to 'Error messages' in the 'Trouble shooting' section.

Starting the electric motor

- The electric motor is started by pressing the start button.

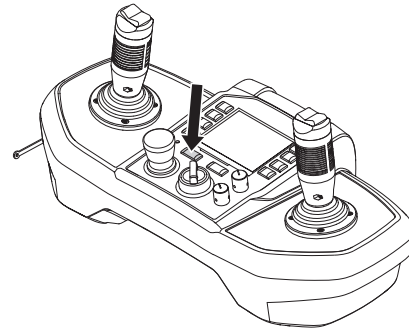

- If several machines are used at the same workplace there is a risk of mixing up the remote controls. Press the horn to see which machine is connected to the remote control. The machine will beep and flash three times. Do not activate the remote control before you have ensured that the correct machine is being operated.

Activating controls

- To activate the remote control's operating functions press the left button on the right joystick. The remote control is now in work mode. The light emitting diode on the remote control has a permanent blue light.

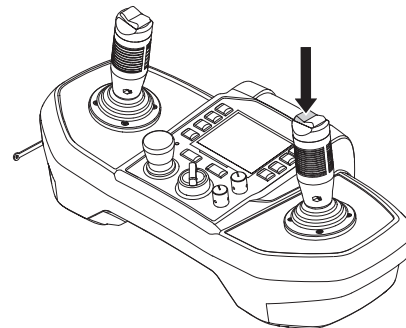

- If no command is given within three seconds the operating functions are locked. To return to work mode, press the left button on the right joystick.

Stopping

- Maneuver the arm system down and allow it to rest against the ground.
- Put all controls into neutral position.
- Press the stop button.
- Put the main switch into the OFF position (O).

Inspection after work

It can be beneficial to carry out the daily inspection after finishing work. Detecting damage in time can prevent a shutdown on the following day.

OPERATION

Operating modes

The machine can be operated in three different modes: transport mode, set-up mode and work mode. All commands in each of the modes are described in this section.

- Work mode - In this mode you can operate everything except the caterpillar tracks and outriggers.
- Set-up mode - In this mode you can operate the caterpillar tracks and outriggers.
- Transport mode - In this mode you can operate the caterpillar tracks and some arm functions.

If no controls have been used for three seconds the machine goes into idling mode. In this mode hydraulic oil is pumped into the tank and there is no pressure in the cylinders.

Option

External tools

External hydraulic tools can be connected to the machine. The mode is activated by pressing the button for external tools. In this mode the machine cannot be operated from the remote control.

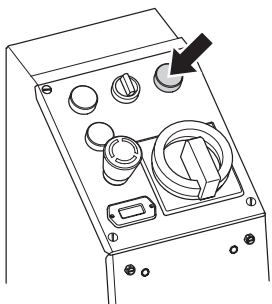

Emergency operation



IMPORTANT!

To be driven in the emergency operation mode the machine must be fitted with hand levers.

Emergency operation is used in conjunction with terminal or control system problems. The mode is activated by putting the knob into the position for emergency operation.

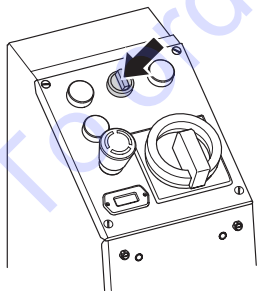

When emergency operation is activated the machine turns off and has to be restarted using the start button on the machine. In this mode the machine can only be moved using emergency operation, other functions are disconnected. When emergency operation is deactivated the machine turns off and has to be restarted using the remote control.

Key to commands

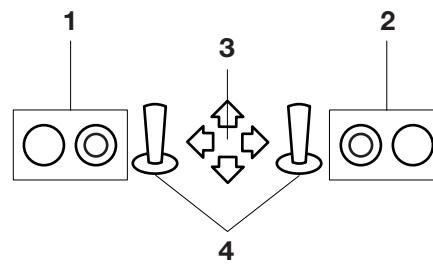

1. Right and left button on right joystick
2. Right and left button on left joystick
3. Direction joystick
4. Left and right joystick respectively

Designation of the machine's parts

1. Arm 1
2. Arm 2
3. Arm 3
4. Tool
5. Outrigger
6. Caterpillar tracks
7. Tower

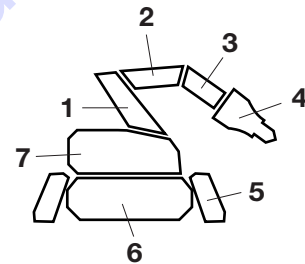

OPERATION

Work mode

Rotate tower counterclockwise		
Rotate tower clockwise		
Arm 1 in		
Arm 1 out		
Arm 2 down		
Arm 2 up		
Arm 2 telescope out		
Arm 2 telescope in		
Arm 1 and arm 2 out		
Arm 1 and arm 2 in		
Arm 3 up		
Arm 3 down		
Angle tool inwards*		
Angle tool outwards*		
Adjustable flow to the hammer		
Full flow to the hammer		
Cutters open/close**		

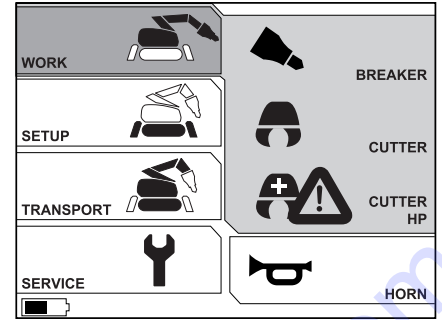

* The function works even if the right button on the right joystick is depressed. This can be useful if you simultaneously want to run arm 1 and 2 in parallel.

** The button that opens/closes the cutters varies depending on which type of cutters are being used.

OPERATION

Set-up mode

Track operation

Right track operation forward 

Right track operation backwards 

Left track operation forward 

Left track operation backwards 

Outriggers

Right outrigger down 

Right outrigger up 

Rear right outrigger down 

Rear right outrigger up 

Front right outrigger down 

Front right outrigger up 

Left outrigger down 

Left outrigger up 

Rear left outrigger down 

Rear left outrigger up 

Front left outrigger down 

Front left outrigger up 

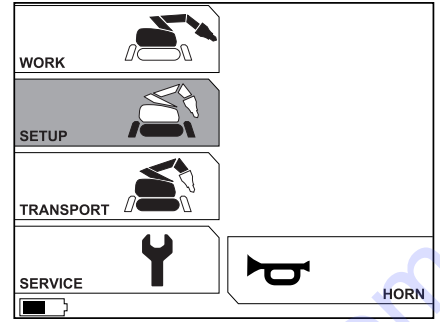
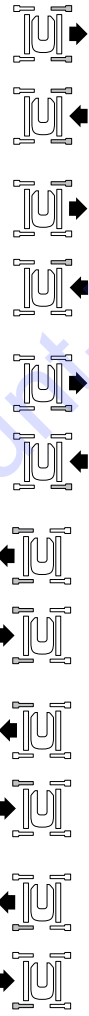
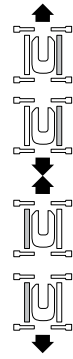

OPERATION

Transport mode

Right track forward
left track forward

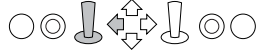

Right track backwards
left track forward

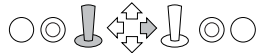

Rotate tower clockwise

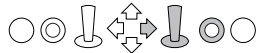

Rotate tower counterclockwise

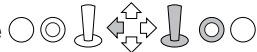

Caterpillar tracks forward



Caterpillar tracks backwards



Arm 1 out



Arm 1 in



Arm 2 down



Arm 2 up



Arm 2 telescope out



Arm 2 telescope in



Arm 1 and arm 2 out



Arm 1 and arm 2 in



Arm 3 up



Arm 3 down



Angle tool inwards



Angle tool outwards

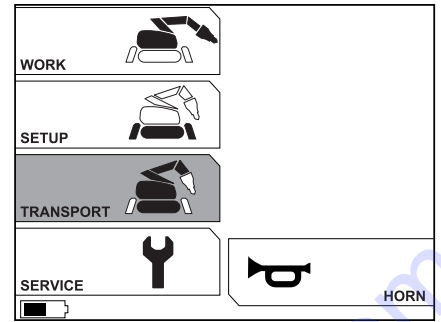
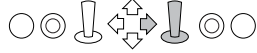

General



IMPORTANT!

Please read the operator's manual carefully and make sure you understand the instructions before using the machine. You should also read and understand the manual that accompanies the tool.

Ensure that the tool's and the machine's performance (weight, hydraulic pressure, flow etc) are compatible.

Bucket

The bucket is designed to move material. It is not designed for use as a lifting implement.

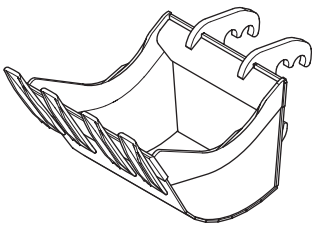

Hydraulic hammer

The hydraulic hammer is designed for demolition by means of hewing. It is not designed for use as a crowbar. Continuous hewing with the hydraulic hammer can result in high temperatures in the hydraulic system.

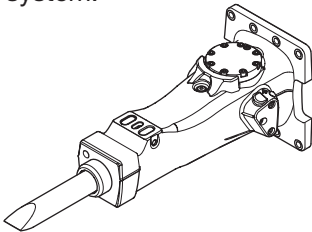

Concrete cutter

The concrete cutters are designed to crush and cut material in their jaws. They are not designed for pulling and prizing loose material.

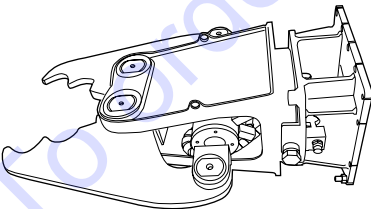

Work mode

You can select which tool you want to work with in the work menu - hammer, concrete cutter or concrete cutter with increased work pressure.

NB! There is a risk of damage to the machine if, for example, the work pressure is delivered to a single-acting tool's return side, or if the machine's or the remote control's settings are not correct for the tool in question. There is more information about the remote control's settings in the "Control system" section.

Changing tools



IMPORTANT!

Changing tools may mean that the operator has to be within the machine's risk area. Ensure that nobody unintentionally starts the machine while the tool is being changed. Keep a sharp watch on the machine and be prepared to turn it off. Guard hands and feet against crushing.

Cleaning

Prevent dirt from entering the hydraulic system by:

- Wiping dirt off the couplings before assembling or dismantling.
- Placing dust guards on the machine's hydraulic couplings when no tool is mounted.
- Ensuring that the tool's hoses are always connected together when the tool is not connected to the machine.

Fitting



IMPORTANT!

Ensure that the tool is correctly and securely fitted. If a tool unexpectedly comes loose it can cause personal injury.

- Ensure that the machine is situated on a stable surface with the outriggers down.
- Position the tool with the holder facing the machine at a suitable distance, not too close to the machine.
- Ensure that the tool is turned the right way round. The tool's pressure connection must be connected to the main valve's B-port and the return hose to the main valve's A-port.
- Direct the tool holder so that it grips the tool. Tighten the tool by raising the arm system and maneuvering cylinder 4 in.

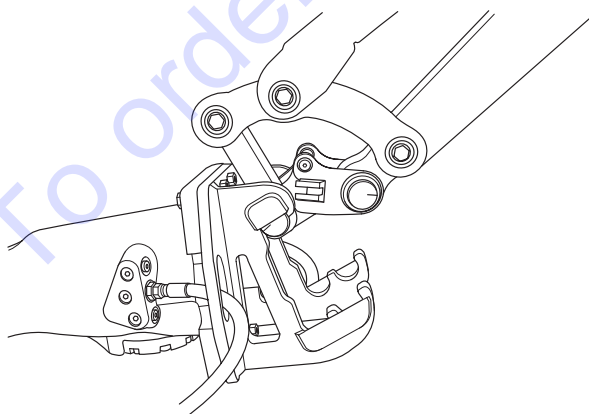

- Shut off the machine.
- Insert the wedge so that the holes for the locking pin fit.
- Insert the locking pin.

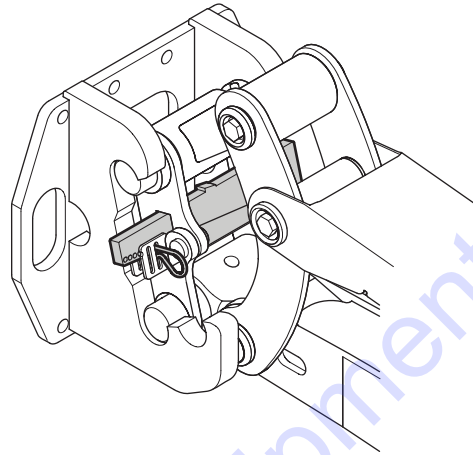

- Connect the hydraulic hoses and any hoses for hammer lubrication (when fitting the hammer). The tool's pressure connection must be connected to the main valve's B-port and the return hose to the main valve's A-port.

The hydraulic hoses are equipped with bayonet couplings with decompression. This facilitates fitting the hoses even though pressure is trapped.

To dismantle, follow the instructions in the reverse order.

Storage

Store the tools safely and inaccessible to unauthorised people. Ensure that they are in a stable position and cannot tip over. If tools are placed high up or on a slope they must be secured so that they cannot be put into motion or fall. Protect the tools' hydraulic couplings against dirt and damage.

Track widener

The machine is equipped with track wideners for increased stability when working with the machine.

Width with track widener: 1110 mm (44 in)

Width without track widener: 780 mm (31 in)

Fitting the track widener

- Let down the outriggers.
- Shut off the machine. Disconnect the power cable and place it so that it cannot be connected by mistake.

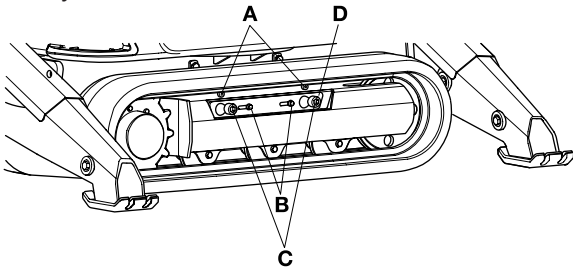

- Remove the nuts (A).
- Loosen bolts (C) and nuts (B).
- Move washer (D) to the side.
- Pull the side of the tracks out a sufficient distance to enable the track widener to be fitted.
- The holes of the track widener must be facing the machine.
- Move the side of the track towards the machine.

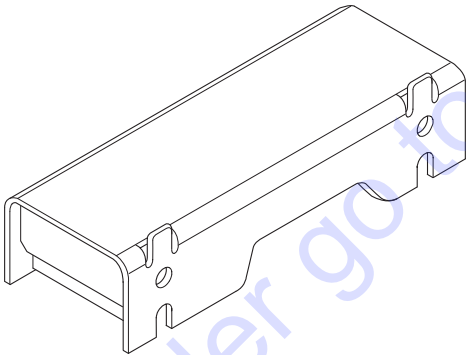

- Tighten bolts and nuts.

To dismantle, follow the instructions in the reverse order.

SETTINGS

Menu system

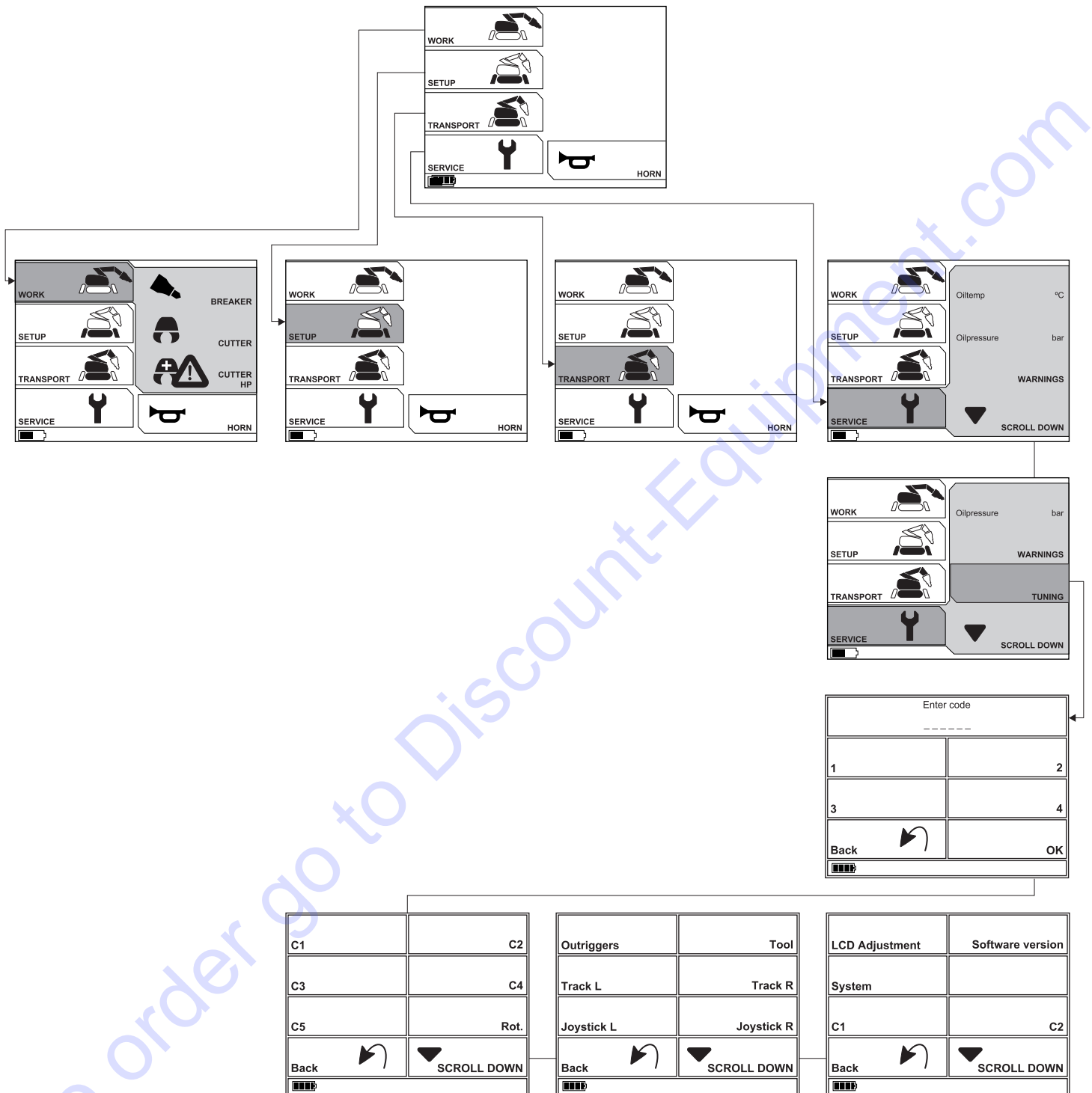

Operational settings

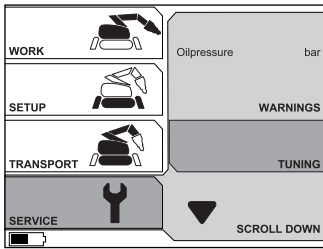

LCD Adjustment

Use the arrows up and down to adjust the display's contrast and brightness.

Software version

This shows the version of the software in the terminal and the two control modules.

Tuning

The following components can be adjusted in the Service Menu under Tuning.

- C1-C5 (Cylinder 1-5)
- Rot. (Rotation tower)
- Outriggers
- Tool
- Track L/R
- Joystick L/R
- System

C1-C5, Rot., Outriggers, Tool, Track L/R

Ramp

Ramp adjusts the acceleration of the drive. The higher the ramp value the slower the acceleration.

Max./min. current

Max./min. current indicates the current interval that governs the prop. valve.

A high minimum value means that the valve opens rapidly. This might mean that it is not possible to employ a function gently.

A low maximum value means that the valve does not open entirely and that the function cannot be run at maximum speed.

A high maximum value means that the valve's maximum opening position is achieved more rapidly.

P/I value

The P and I values are the parameters that govern the regulator. P is proportional regulation and I is integrating regulation.

High values of P and I produce a faster response but can lead to oscillating movements.

Joystick L/R

Pos. and Neg. Progression

Pos. and Neg. Progression indicate the sensitivity of the joystick. The higher the value the more sensitive the joysticks are in their outer positions.

Deadband

Deadband indicates the position in which the joysticks start to be activated. The higher the value the farther out from neutral position that the joysticks are activated.

System

Oiltemp_{high1}

Oiltemp_{high1} is the limit level where the operator receives the service message "Oil temperature is above T_{high1}" in the display.

Oiltemp_{high2}

Oiltemp_{high2} is the limit level where the operator receives the service message "Oil temperature is above T_{high2}" in the display.

Oiltemp_{low}

Oiltemp_{low} is the limit level where the operator receives the service message "Oil temperature is below T_{low}" in the display.

Restore default

Restore default restores all values in the Tuning menu.

General



WARNING!

Most accidents involving machines occur during trouble shooting, service and maintenance as staff have to locate themselves within the machine's risk area. Prevent accidents by being alert and by planning and preparing the work.

If service operations or trouble shooting does not require the machine to be switched on, the power cable must be removed and positioned so that it cannot be connected by mistake.

If servicing operations require the motor to be in operation, be aware of risks when working with or in the vicinity of moving parts.

Perform maintenance and servicing in accordance with this Operator's Manual to avoid shutdowns and to maintain the machine's value.

Maintain the machine's supplementary equipment and tools as well.

The user must only carry out the maintenance and service work described in this Operator's Manual. More extensive work must be carried out by an authorized service workshop.

Use only original spare parts for repairs.

Measures to take in advance of maintenance, service and trouble shooting

General

- Ensure that the machine is situated in a safe area.
- Place the machine on a flat surface with the arm system and outriggers down.
- Several components heat up during work with the machine. Do not commence any servicing or maintenance tasks until the machine has cooled.
- Set out clear signs to inform persons in the vicinity that maintenance work is in progress.
- Ensure that the working area is sufficiently illuminated to create a safe working environment.
- Ascertain the location of fire-extinguishers, medical supplies and emergency telephone.

Protective equipment

- Wear personal protective equipment. See instructions under the heading "Personal protective equipment".
- Use an approved lifting device to secure and lift heavy machine parts. Also ensure that there is equipment to secure machine parts mechanically.

Working environment

- The area around the machine must be free of dirt in order to minimize the risk of slipping.
- Clean the machine. Dirt in the hydraulic system leads rapidly to consequential damage and stoppages.
- Ensure that there is a sufficiently large working area.

Discharge stored energy

- Turn off the motor.
- Put the main switch in the OFF position (O).
- Disconnect the power cable and place it so that it cannot be connected by mistake.
- When maintaining the track unit, discharge the pressure in the accumulator. Refer to the directions under 'Functional inspection' in the 'Maintenance and service' section.

Discharge pressure in the hydraulic system

- Undo the air filter so that the overpressure in the tank is discharged.
- Discharge pressure in the hydraulic cylinders by taking the load off the arm system by resting it on the ground.
- Wait until the pressure has decreased via internal leakage.
- When maintaining the track unit, discharge the pressure in the accumulator. Refer to the directions under 'Functional inspection' in the 'Maintenance and service' section.

Dismantling

- When dismantling machine parts, heavy components can start moving or fall down. Secure moving parts mechanically before loosening screw joints or hydraulic hoses.
- Pipe and hose couplings can remain pressurized despite the motor being switched off. Always work on the assumption that the hoses are under pressure when dismantling. Take great care when undoing connections and use appropriate personal protective equipment.
- Make sure to mark all cables and hoses that are undone in conjunction with service and maintenance in order to ensure correct reassembly.

Test running the machine

- The machine's movements can be defective if a terminal, cable or hose is incorrectly mounted. Exercise caution during test runs and be prepared to turn the machine off immediately in the event of a fault.

Cleaning



IMPORTANT!

Turn off the motor. Disconnect the power cable and place it so that it cannot be connected by mistake.

The area around the machine must be free of dirt in order to minimize the risk of slipping.

Use suitable personal protective equipment.

- When cleaning the machine there is a risk of getting dirt and harmful substances in the eyes, for example.
- Dirt and harmful substances can be released from the machine when using high pressure equipment.
- High-pressure jetting using water or air can permeate into the skin and cause serious injury. Never aim a high-pressure jet towards the skin.

Cleaning method

The cleaning method varies depending on type of contaminants and how dirty the machine is. A mild degreasing agent can be used. Avoid skin contact.

NB! High-pressure washing and compressed air should be used with extreme caution, incorrect use can damage the machine.

Bear the following in mind when using high-pressure washing:

- High-pressure washing with the wrong nozzle or high pressure can damage electrical components, electric cables and hydraulic hoses.
- The high pressure jet can damage seals and lead to water and dirt permeating into the machine, resulting in serious damage.
- Stickers can be washed away.
- The surface finish can be damaged.

Cleaning of components

There are a number of components that require special consideration when cleaning.

Hydraulic tank

Place a plastic bag over the tank's air filter and seal it with a rubber band to avoid water getting into the tank.

Cooler

Allow the cooler to cool down before cleaning. Use compressed air to clean the air fins. If necessary, use high-pressure washing and degreasing agent. Incorrect use of high-pressure washing or compressed air can distort the cooler's fins and thereby impair the cooling capacity.

- Max. pressure 100 Bar.
- Spray directly towards the cooler, in parallel with the fins.
- Keep a distance of about 40 cm between the cooler and the nozzle.

Electrical components

Clean electric motor, electric cabinet, terminals and other electrical components with a cloth or with compressed air. Do not spray water at electrical components. Dry the remote control with a damp cloth. Never use high-pressure washing. Blow clean internally using compressed air.

After washing

- Lubricate all the machine's lubrication points.
- Blow electrical terminals dry using compressed air.
- Exercise caution when the machine is started after washing. If any components have been damaged due to moisture, the machine's movements can be defective.

MAINTENANCE AND SERVICE

Service schedule

The service schedule is based on the machine's operating time. More frequent service intervals might be necessary when working in dusty or hot environments and in conjunction with work that generates high temperatures. A description of how the operations are to be performed is to be found in the service review.

Daily inspection

Daily maintenance must also be carried out after transportation.

Lubrication

Cylinders and shafts in arm system and tool attachment
Tools

Cracks

Cylinders and shafts in lower part and outriggers
Cylinders and shafts in arm systems and tool attachment
Tools

Mountings

Cylinders and shafts in lower part and outriggers
Cylinders and shafts in arm system and tool attachment
Tool

Level check

Hydraulic fluid
Hammer lubrication

Wear and damage

Cylinders and shafts in arm system and tool attachment
Visible hoses (arm system, outriggers etc)
Power cable, connectors and sockets

Leakage

Cylinders and shafts in lower part and outriggers
Cylinders and shafts in arm system and tool attachment
Visible hoses (arm system, outriggers etc)
Tool

Function

Cylinders and shafts in lower part and outriggers
Cylinders and shafts in arm system and tool attachment
Power cable, connectors and sockets
Tool

MAINTENANCE AND SERVICE

Weekly service

Carry out a daily inspection as per the service schedule before you carry out the weekly service.

Lubrication

Cylinders and shafts in lower part and outriggers
Drive, track sides and track tensioning
Gear ring

Cracks

Drive, track sides and track tensioning

Mountings

Drive, track sides and track tensioning
Power unit (motor, fan, fan housing)

Wear and damage

Cylinders and shafts in lower part and outriggers
Drive, track sides and track tensioning
Hoses

Leakage

Hoses
Other hydraulic components

Function

Drive, track sides and track tensioning
Cooler
Slew motor
Hammer lubrication
Emergency stop/machine stop

Miscellaneous

Clean the entire machine
Clean the cooler

MAINTENANCE AND SERVICE

After the first 100 hours

Change

After the first 100 hours the following maintenance should be carried out, subsequently every 1,000 hours.

Slew motor, slew reduction gear unit - oil change

Drive motor, drive gear – oil change

250 hours service

Carry out the weekly service as per the service schedule before you perform the 250 hours service.

Mountings

Drive motor, drive gear

Slew motor, slew reduction gear unit

Gear ring rotation

Level check

Slew motor, slew reduction gear unit

Function

Drive motor, drive gear

Slew motor

Gear ring

Miscellaneous

Hydraulic pump – checking of unusual sounds

Hydraulic hammer – checking of bushing and wrecking bar

500 hours service

Carry out the 250 hours service as per the service schedule before you perform the 500 hours service.

Change

Hydraulic fluid

Oil filter

Air filter

Servo filter and pressure steering filter

1,000 hours service

Carry out the 500 hours service as per the service schedule before you perform the 1,000 hours service.

Change

Slew motor, slew reduction gear unit - oil change

Drive motor, drive gear – oil change

MAINTENANCE AND SERVICE

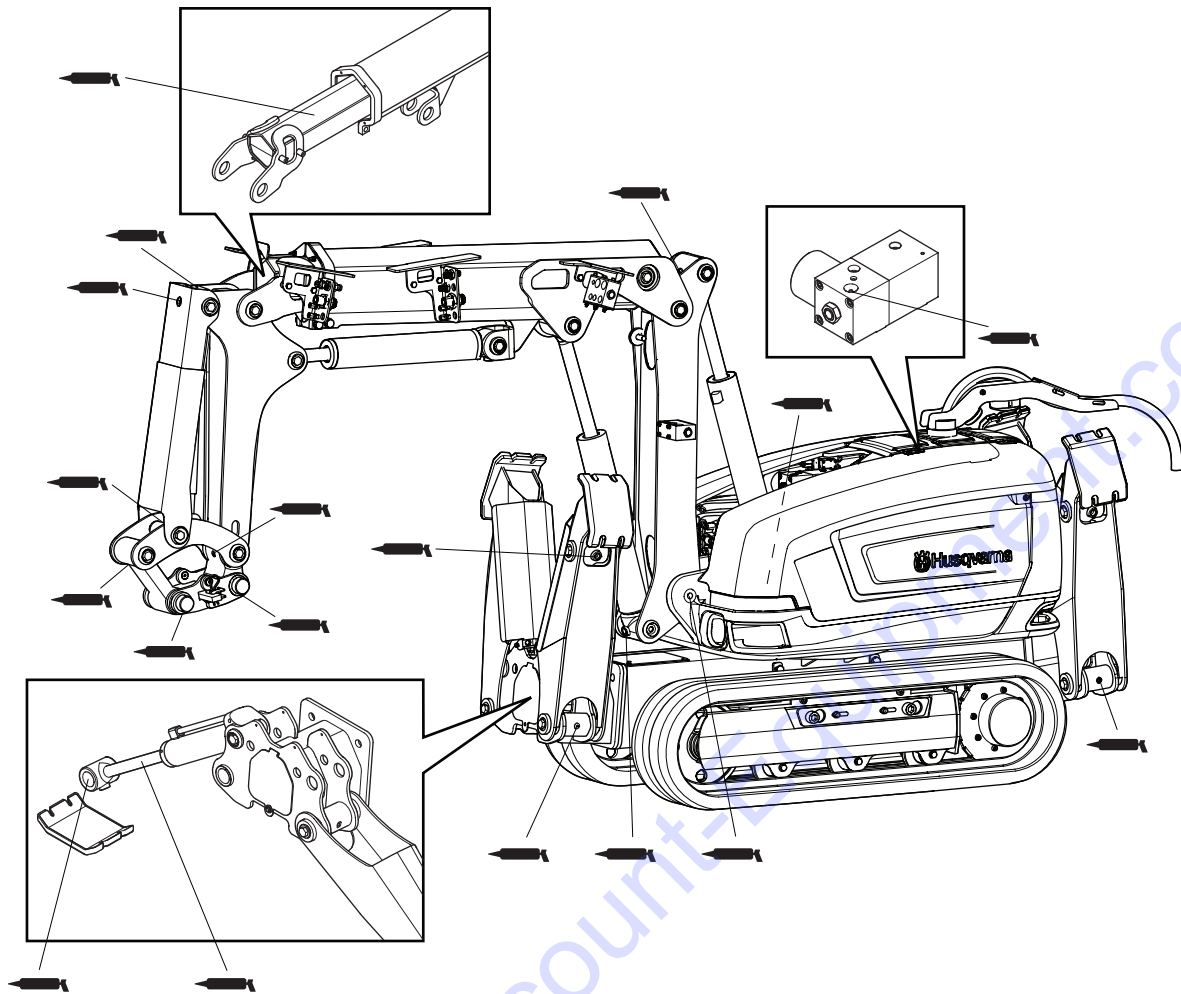

Service review



WARNING!

Ensure that nobody starts the machine while service is taking place. Turn off the motor when the machine has been moved to the desired location. Disconnect the power cable and place it so that it cannot be connected by mistake.

Lubrication

The machine can be moved to a position to access all grease nipples (see picture).

Do as follows:

- Clean the nipple before greasing.
- Replace broken or blocked nipples.
- Connect the grease gun and pump 3-5 strokes. Use lubricating grease as per the "Hydraulic fluid and lubrication" table in the "Technical data" section.

Make a habit of always applying lubrication in the same order in order to more easily remember all lubrication points.

Outriggers and arm system

- Lubricate all joints and cylinder mountings.
- The inner tube of the telescopic arm has to be lubricated. Operate the telescopic arm to its outer end position. Apply grease to the arm's sliding surfaces.

Gear ring

The gear ring has separate grease nipples for bearings and cogs. To ensure that the grease is evenly distributed it should be applied followed by rotation and then applied again.

- Connect a grease gun and grease the nipples.
- Stand at a safe distance, start the machine, rotate the upper part by 90° and then turn off the motor.
- Repeat three times so that the gear ring's bearings and cogs are lubricated in four places.

NB! If the instructions are not followed there is a high risk of the gear ring's seals being forced out. The gear ring's bearings are then open to dirt and the seals have to be replaced.

MAINTENANCE AND SERVICE

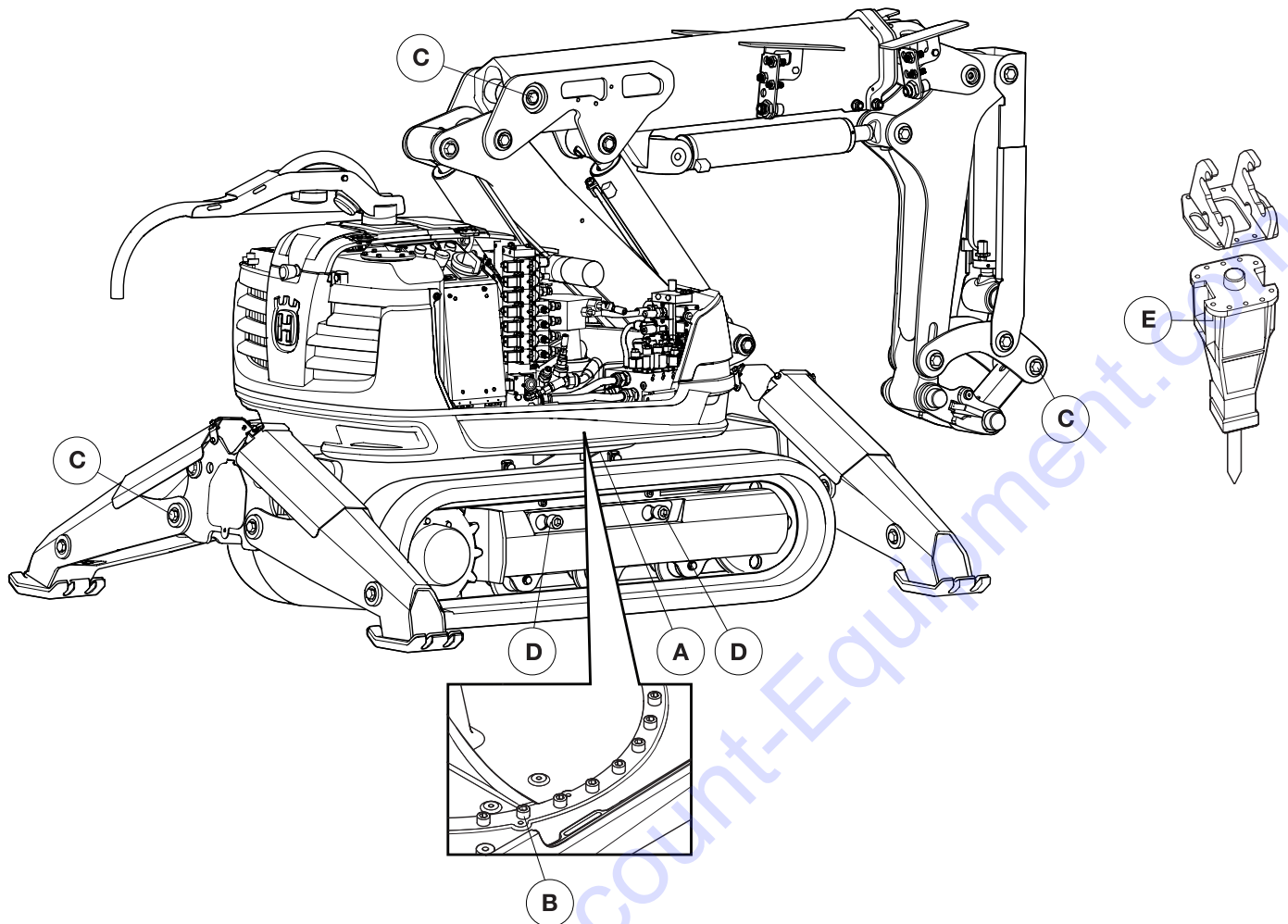

Mountings

General

Check that all components are properly secured by feeling, pulling etc. Keep a look out for wear damage. This can be caused by components coming loose.

- A bolted joint that is secured with adhesive should not be tightened. Simply check that it is tight. If a glued bolted joint has come loose, clean the threads before fresh adhesive is applied.
- Check the shafts with respect to mounting/locking. Check expanding shafts by tightening with a torque wrench.
- Locking pins must be checked with respect to damage and mounting.

Shafts

- The design of the expanding shafts ensures that there is not too much play provided that they are tightened regularly. New expanding shafts must be tightened frequently until they have bedded in. Wear damage on the expanding shaft's sleeve is a typical sign that they have not been tightened correctly or sufficiently often.
- If an expanding shaft has slipped out of position it is important that it is centered before being retightened again.

Tightening torque

Use abutment when torquing through shafts to avoid the shaft rotating.

Pos.		Nm
A	Gear ring bearings against chassis beam	81
B	Gear ring bearings against base plate	81
C	Shafts, arm system, outriggers	175
D	Track sides	500
E	Tool against adapter plate	197

MAINTENANCE AND SERVICE

Level check

Position the machine on a flat surface. Clean the component before it is opened for reading or filling in order to prevent dirt entering the system. If the oil level is low, refill with the type and quality as per the 'Hydraulic fluid and lubrication' table in the 'Technical data' section.

Hydraulic oil

- Maneuver the machine so the arm system's cylinders are retracted and the outriggers are completely folded.
- Refilling is needed if the level is more than one cm below the max mark.

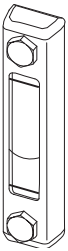

Slew reduction gear unit

- Locate and loosen the dipstick. Wipe it clean, lower it and read off the level.

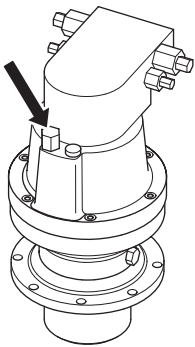

Drive motor, drive gear

- Maneuver the machine until one of the plugs is level with the middle of the hub and the other one is at the top position.
- Unscrew the level plug. The oil level should reach up to the hole.

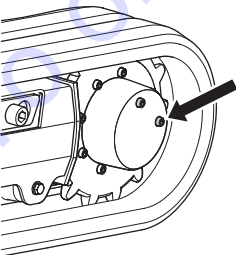

Hammer lubrication

- Check that there is grease in the receptacle.

Wear and damage

General

NB! Deal with worn components as quickly as possible. There is an increased risk of mechanical breakdown if the machine is used despite damaged or worn components.

Wear of shafts and slide bearings

Bearings and any shafts necessary must be replaced in the event of play in joints and cylinder mountings. Replace or repair damaged components.

- If there is play in joints the bearings must always be replaced.
- Shafts must be replaced if they have wear damage. If there is wear damage on an expanding sleeve it indicates that it has not been sufficiently tightened.
- Swing joints must be kept lubricated in order to be able to press out dirt that enters and to reduce wear on shafts and bearings.

Wear to rubber components

Check that caterpillar tracks and outrigger feet are intact. If they are so worn that the metal is visible they should be replaced.

Wear to hydraulic hoses

Do not use hoses that are distorted, worn or damaged. Make sure that the cords are not visible. Always have a spare hose on hand. Damaged hoses must be replaced immediately.

- Check that none of the hoses are rubbing against sharp edges. Be alert to the risk of abrasive jets.
- Adjust the length of hydraulic hoses so that they are never entirely stretched.
- Ensure that the hose is not twisted during mounting.
- Avoid severe bends in the hose.

Hydraulic couplings

- Check that the couplings are not damaged. Damaged couplings can damage hoses with the result that they come off. Change damaged couplings immediately.
- The hydraulic couplings should be lubricated before tightening to reduce friction.

Wear to electric cables



WARNING!

The power cable must be disconnected when electric cables are checked. Check that the cables' insulating casings are not damaged. Change damaged cables immediately.

MAINTENANCE AND SERVICE

Leakage

General

NB! Leakage can cause serious mechanical breakdowns and an increased risk of slipping. Wash the machine regularly to increase the chance of detecting leakage at an early stage. Deal with leaks as quickly as possible and refill if necessary.

Hydraulic fluid

Leakage of hydraulic fluid leads to an increased risk of dirt getting into the hydraulic system which can lead to breakdowns and mechanical damage. If you detect hydraulic fluid underneath the machine or on the base plate it is probably due to leakage.

- Check for leakage at the hose connectors, couplings and cylinders. Leakage can also occur at other hydraulic components and can manifest itself with a strip of dirt.

Cracks

General

A clean machine makes it easier to detect cracks.

The greatest risk of crack formation is:

- At weld seams
- At holes or sharp corners

Lower part

- Check in particular whether cracks have appeared around outrigger mountings both on the lower part and on the outriggers, gear ring mounting and weld seams between the machine body and the track sides.

Arm system

- Check in particular whether cracks have appeared on the arm system's joints, cylinder mountings and weld seams.

Welding work on the machine

Only qualified welders should carry out welding operations on the machine.



WARNING!

Risk of fire. The machine contains flammable liquids and components. Do not undertake any welding in direct connection with flammable liquids, e.g. in the vicinity of tanks, fuel lines or hydraulic pipes. Ensure that there is a fire-extinguisher on site at the workplace.

Risk of inhaling harmful substances. Toxic gases can be formed. When welding indoors, use equipment to extract welding fumes. Never weld in the vicinity of rubber or plastic material. Use a breathing mask.

Components that should not be welded

The following components should not be repaired but replaced:

- Tool attachment
- Link
- Cotters
- Mounting plate
- Cylinders
- Hydraulic tank
- Cast parts

Recommended welding wire

Type	Recommended material
Flex cored wire	Esab OK 14.03 Tubrod Class: AWS A5.28 E110C-G
Solid	Elgamatic 100 Class: AWS A5.18 ER70S-6
Rod	Esab OK 75.75 Class: AWS A5.5 E11018-G

MAINTENANCE AND SERVICE

Functional inspection

General

Functional inspections must ensure that the machine's functions are intact.

Brake functions

- Check the drive brake's function by operating the machine on a slope. Release the joysticks. The machine should then be braked and remain stationary.
- Check the slew brake's function by rotating the arm on a slope. Release the joysticks. The arm should then be braked and stop gently.

Cooler

Overheating has a negative effect on the service life of the machine's components. Clean the cooler when necessary. Refer to "Cleaning the machine" in the "Maintenance and service" section.

Cylinders

Checking cylinder tubes and piston rods must be done with the cylinders extended to the end position. Replace damaged components immediately.

- Check that the cylinder tubes are not dented or cracked.
- Check that the piston rods are undamaged and straight. A damaged piston rod causes contamination in the hydraulic system, resulting in mechanical damage.

Tool attachment



Warning!

The tool attachment's cotter and pin are important safety components. A worn or damaged cotter must be replaced with an original spare part, manufacturing your own cotters is not permitted.

- Check that the tool attachment is complete and that all parts are intact and correctly mounted.

Automatic track tensioning

The caterpillar tracks are tensioned automatically when the outriggers are up.

Should demolition material or suchlike enter into the side of the tracks during operation, their spring function should prevent breakdowns and stoppages. The spring function consists of a hydraulic accumulator.

Checking track tension

- The track must not slacken by more than 10-15 mm. Operate the outriggers up and then down. Wait 15 minutes and then check.

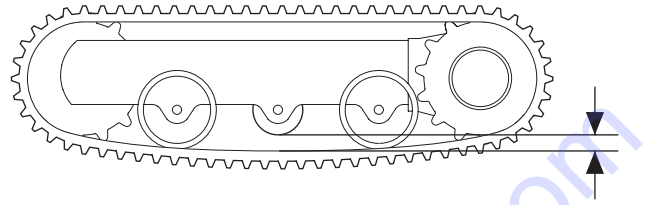

- If the tracks become slack it can be due to one of the track tensioning function's non-return valves being blocked or broken.

Cleaning non-return valves

The non-return valves can be cleaned by discharging the pressure in the accumulator and thus loosening the tension of the tracks.

- Pull out the valve and rotate it a quarter turn to lock it in open position.

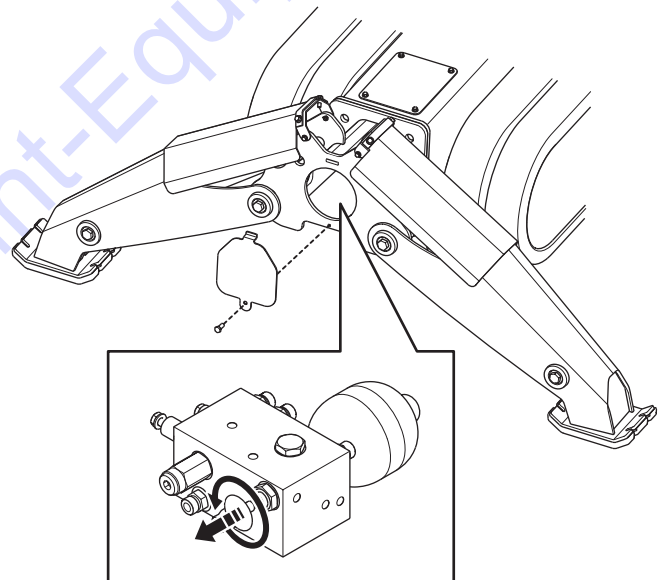

- Operate the outriggers up and down. Hydraulic fluid is then pumped around and cleans the non-return valve.
- Rotate and release the valve back into position. Operate the outriggers up and down to tension the track.

Hammer lubrication

Check that grease is reaching the hammer by dismantling the grease hose at the hammer. Start the machine and activate the hammer function. Exercise great caution during the inspection to ensure that nobody is injured.

Tools

Check that the tool can be used in such a way that neither the operator nor people in the vicinity are exposed to unnecessary risks. Refer to the supplier's Operator's Manual for other checks.

MAINTENANCE AND SERVICE

Change



IMPORTANT!

Chemicals such as degreasing agent, grease, fuel, glycol and hydraulic fluid can give rise to allergies in conjunction with repeated skin contact. Avoid contact with the skin, use protective equipment.

General

Changing liquids and filters must be done in such a way that the machine's hydraulic system and the surrounding environment are not damaged. Dispose of residual products according to local laws.

Position the machine on a flat surface. Discharge the machine and allow it to cool. Clean the component before opening it for refilling in order to prevent dirt getting in. If the level is low, fill in accordance with the following instructions.

Hydraulic fluid



IMPORTANT!

Allow the machine to cool. Hot oil can cause severe burn injuries.

General

The quality of hydraulic fluid that the machine was supplied with is indicated on the sticker on the machine's hydraulic tank. Refer also to 'Technical data' for choice of suitable hydraulic oils.

OBS! The machine can be damaged if different types of hydraulic fluid are mixed. Check which quality of hydraulic fluid the machine's hydraulic system contains before refilling or changing. Do not use hydraulic fluid that is not recommended.

Draining hydraulic fluid

- Maneuver the machine so the arm system's cylinders are retracted and the outriggers are completely folded.
- Undo the air filter so that the overpressure in the tank is discharged.

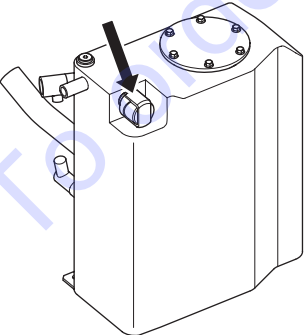

- Place a collecting vessel under the tank's drain plug and open the plug.

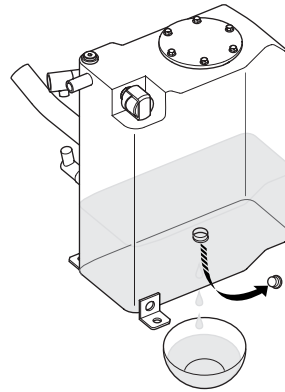

- Screw on the drain plug when all the liquid has drained out.
- Changing oil filters. Refer to 'Oil filter' in the 'Maintenance and service' section.
- Tighten the air filter.

NB! Do not start the motor when the hydraulic tank is empty, the hydraulic pump will be damaged.

Replenishing hydraulic fluid

The machine is equipped with a refill pump.

- Maneuver the machine so the arm system's cylinders are retracted and the outriggers are completely folded.
- Clean the refill pump's suction hose. Remove the plug and put the hose into the fluid container.
- Press in the refilling button to start the pump.

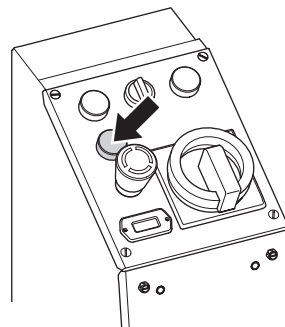

- Use the sight gauge to check the oil level when refilling.
- Start the machine and operate the cylinders between outer and inner end position a number of times to remove air that might have entered the hydraulic system while refilling.

Oil filter



IMPORTANT!

Allow the machine to cool. Hot oil can cause severe burn injuries.

- Undo the air filter so that the overpressure in the tank is discharged.
- Thoroughly clean the outside of the filter and the surrounding parts.
- Remove the filter cover. Lift up the sealing ring, the spring and the filter holder together with the filter cartridge.

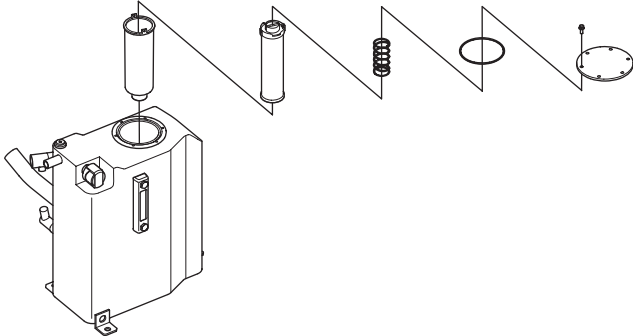

- Remove the filter cartridge from the filter holder.
- Check whether there is an unusually large amount of large metal particles or sealing compound in the filter holder. If this is the case the machine's hydraulic system must be checked for faults.
- Clean the filter holder with degreasing agent. Rinse with warm water and blow dry using compressed air.
- Install the new filter in the filter holder and put it in the tank. Install a new sealing ring.
- Install the spring and the filter cover.

Air filter

- Thoroughly clean the outside of the filter and the surrounding parts.
- Replace the filter.

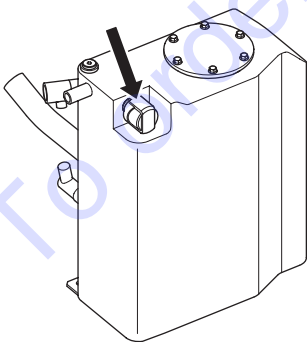

TROUBLE SHOOTING

Error messages

There are two types of error messages that can appear on the display:

- Service messages - These messages do not represent any direct danger for the operator or the machine.
- Warnings - These warn of faults or safety defects that can cause mechanical damage.

All error messages that have been acknowledged remain as small yellow red warning triangles in the field for service and can be accessed by bringing up the service menu and selecting 'Warnings'. The messages are listed in order of priority, highest priority first.

When a fault that has in some way restricted the machine's functions ceases, a message appears on the display. This message must be acknowledged for the machine to return to full functionality.

Service messages

When a service message appears on the display, the operator is made aware of it through the work light flashing three times.

The service message remains on the display until the operator has acknowledged it. The message disappears from the display and is replaced by a yellow warning triangle in the field for service. The triangle symbol remains for as long as the message is current.

Service messages and actions

Service message	Action
Oil temperature is above T_{high1}	Oil temperature is above 80°C (176°F). Put the machine into circular pumping mode to cool the hydraulic fluid.
Oil filter needs to be changed	Change the oil filter at once.
Low battery	Approx. 30 mins operating time left. Charge the battery.

Warnings

When an error message appears on the display, the operator is made aware of it through the work light flashing continuously. The machine is put into idling mode in connection with the warning. If the message is not acknowledged the horn sounds and the motor is turned off.

The operator acknowledges the warning message by selecting override. The light stops flashing and the message disappears from the display and is replaced by a red warning triangle in the field for service. The triangle symbol remains for as long as the message is current.

In override mode, certain machine functions can be used up to 50%. This function is available in order to move the machine away from hazardous environments.

Warning messages and actions

Warning message	Action
Oil temperature above T_{high2}	Oil temp. over 90°C (194°F). Put the machine into circular pumping mode to cool the hydraulic fluid.
Oil temperature below T_{low}	Oil temp. below 10°C (50°F). Warm the machine up to 40°C (104°F) before starting work.
Phase Error	Voltage too high or out of phase. Check incoming voltage.
Motor Over Temperature	The motor decreases to half-speed due to overheating. Normal operation can be resumed when the temperature has normalized.
NO OIL PRESSURE	Fault in the phase rotation relay resulting in motor and pump running in the wrong direction. Check that the motor is running in the right direction.
IDLE PRESSURE TOO HIGH	The oil pressure does not fall when the machine is put into circular pumping mode. Fault in the pump-around valve.

Emergency stop/machine stop

If the machine stop on the remote control or the emergency stop on the machine are pressed or if the function does not work, a message will appear in the display at start up. Check and confirm the message. If you are still unable to start the machine, contact Discount-equipment.

If the message has not been confirmed within 10 seconds the horn will sound together with the flashing light.

TROUBLE SHOOTING

Trouble shooting guide



WARNING!

Most accidents involving machines occur during trouble shooting, service and maintenance as staff have to locate themselves within the machine's risk area. Prevent accidents by being alert and by planning and preparing the work. You can also refer to 'Preparations for maintenance and service" in the 'Maintenance and service" section.

If service operations or trouble shooting does not require the machine to be switched on, the power cable must be removed and positioned so that it cannot be connected by mistake.

Following the trouble shooting guide will provide you with tips to facilitate the trouble shooting process. You can also perform simpler trouble shooting operations. The operator may only carry out the maintenance and service operations that are described in this Operator's Manual. More extensive interventions must be carried out by an authorized service workshop.

Always start by checking any error messages on the remote control. Follow the instructions for the respective message in accordance with the error messages section.

Fault	Cause	Possible action
The electric motor does not start	Emergency stop/machine stop is pressed.	Check that the emergency stop or machine stop button are not pressed by turning them clockwise.
	Too low mains voltage to the machine.	Check power supply and ensure correct voltage.
	A fuse has blown.	Check that the mains voltage is compatible with the machine and that the correct fuses are used.
	No radio communication between remote control and machine.	Green symbol in the display indicates contact. If the symbol does not light up, check that the battery for the remote control is charged and correctly inserted. Ensure that the correct remote control is being used. Check that the communication cable and aerial cable on the machine are properly secured. Test run the machine using cable control.
Fuses for the mains connection blow when starting.	The machine's fuses have too low a rating.	Check that the mains voltage is compatible with the machine and that the correct fuses are used.
	Electric motor blown.	Contact Discount-equipment.
	The hydraulic pump has cut out.	Contact Discount-equipment
The machine works but the motor speed decreases substantially during operation.	Too low mains voltage to the machine.	Check power supply and ensure correct voltage.
	Incorrectly dimensioned power cable.	Ensure that the power cable is correctly dimensioned. Refer to "Guide values for mains connection" in the "Technical data" section.
The motor runs but the hydraulic functions have no power or do not work at all.	Not enough hydraulic fluid in the tank. (Knocking noise coming from the tank.)	Stop the motor at once. Investigate and rectify any leaks there might be. Replenish hydraulic fluid.
	Pump around valve open.	Check the diode on the valve cap at the bottom of valve block 1. If the pump around valve is open the diode does not light up. Check the cable to the control module.
	Fault in the pump regulator.	Extend an unloaded cylinder to its end position and check the pump pressure in the display (under "Service"). If you get maximum pressure the pump regulator is OK.
	Pressure at rest set too low.	Activate the remote control without running any functions and check the setting for pressure at rest in the display. The pressure should not exceed 16 Bar.
Arm movements and tool function run slowly.	The potentiometer that controls mechanical movements/tools is screwed down.	Unscrew the knob(s).
	Pressure at rest set too low.	Activate the remote control without running any functions and check the setting for pressure at rest in the display. The pressure should not exceed 16 Bar.

TROUBLE SHOOTING

An individual function is running slowly.	Restriction in a hydraulic hose.	Extend an unloaded cylinder to its end position and check the pump pressure in the display (under "Service"). If you do not get maximum pressure this indicates a restriction in the hose. Change hose.
	Fault in the pilot control valve.	Contact Discount-equipment
An individual function is not working.	Joystick in an operative position when starting the remote control.	Restart the remote control with the joystick in neutral position.
	Fault in the pilot control valve.	Contact Discount-equipment.
The machine sinks on the outriggers	Leaking direction control valves for outrigger cylinders or internal leakage in the cylinders.	Contact Discount-equipment.
Jerky arm movements	The hydraulic fluid has been heated up in a cold machine.	Warm up the machine.
	A slide valve is seizing due to contamination.	Contact Discount-equipment.
	Air in the pilot control valve.	Contact Discount-equipment.
	Broken O-rings in the pilot control valves.	Contact Discount-equipment.
	Fault in the servo circuit.	Contact Discount-equipment.
Cylinder sinks*	Contamination in the hydraulic system	Investigate any leaks there might be. Change hydraulic fluid and oil filter.
	Leakage in the cylinder.	Locate the leak and replace any components that might be damaged.
	Defective valve	Contact Discount-equipment.
Overheating in the hydraulic system	Cooler blocked or obstructed.	Clean the cooler.
	Too high ambient temperature.	Use forced cooling.
	Maximum pressure or pressure at rest set too high in the pump.	Contact Discount-equipment.
	Defective hose or coupling.	Replace faulty component.
	Restriction in main pipe or pipe to tool.	Replace faulty component.
	Power extraction too high due to faulty or unsuitable tool.	Check that the tool's pressure and flow are compatible with the machine's specification.
	Defective hydraulic pump.	Contact Discount-equipment.
Knocking noise in the hydraulic system	Not enough hydraulic fluid in the tank.	Stop the motor at once. Investigate and rectify any leaks there might be. Replenish hydraulic fluid.
	Air in the hydraulic fluid.	Run the machine without a load until air and fluid have separated.
	Defective hydraulic pump.	Contact Discount-equipment.
Discolored hydraulic fluid	Cloudy grey fluid indicates water in the system.	Investigate and rectify the cause of water entering. Change hydraulic fluid and oil filter.
	Black fluid indicates coke formation due to too high operating temperature.	Investigate and rectify the cause of overheating. Change hydraulic fluid and oil filter.

* If cylinder 3 and 4 slowly sink (approx. 1 cm/min) this is entirely normal as they do not have any counter balance valves.

TECHNICAL DATA

Guide values for mains connection

The power cable must be dimensioned by a qualified person in accordance with national and local regulations. The mains socket to which the machine is connected must be dimensioned for the same amperage as the machine's electrical socket and extension cable, e.g. a 63 A electrical socket must be preceded by a 63 A fuse.

Nominal voltage from power source	Min. voltage at machine	Cable area	Starting current		Motor output	Setting thermal over-load relay	Max. cable length during operation
V	V	mm ²	A		kW	A	m
400	380	6	90*	50 Hz	22,0	44	163
400	380	10	90*		22,0	44	272
400	380	16	90*		22,0	44	435
460	440	6	90*	60 Hz	25,3	44	163
460	440	10	90*		25,3	44	272
460	440	16	90*		25,3	44	435

* Two phases soft start. The directly related phase can be loaded up to 30% more.

The hydraulic system's pressure

Type of pressure		Pressure, Bar
Pump pressure The pressure in the pipes between pump and main stop valve. The pressure varies between pressure at rest and max. pressure depending on which hydraulic functions are being used.	Tool, max*	250
	Rotating function	170
	Outrigger down/up	250/200
	Arm functions	200
Pressure cut-off Functions equipped with pressure cut-off can never be run at a higher pressure than that indicated. The following functions are equipped with pressure cut-off for the respective pressure level.	Telescopic arm	180
	(External hand tool - option)	(140)
Pressure at rest The pressure that the pump delivers when no function is activated and the pump around valves is shut.		20 ±1

TECHNICAL DATA

Hydraulic fluid and lubricant

Hydraulic fluid

Quality	Min. starting temp, °C/°F	Max. temp, °C/°F	Ideal working temp, °C/°F
Mineral oil ISO VG32	-20/-4	75/167	35-60/95-140
Mineral oil ISO VG46	-13/9	87/189	50-75/122-167
Mineral oil ISO VG68	-10/14	97/207	55-80/131-176

Always ask the machine manufacturer before using a type of hydraulic fluid other than those mentioned above.

The quality of hydraulic fluid that the machine was supplied with is indicated on the sticker on the machine's hydraulic tank.

NB! The machine can be damaged if different types of hydraulic fluid are mixed. Check which quality of hydraulic fluid the machine's hydraulic system contains before refilling or changing.

Lubricant

Component	Quality	Standard
Gear ring	SAE 80W-90	API GL 5
Drive motor, drive gear	SAE 80W-90	API GL 5
All lubrication points with grease nipples	NLGI 2	

Preset limit values

Description	Temperature, °C/°F
Oil Temperature High threshold 1 (T_{high1})	80/176
Oil Temperature High threshold 2 (T_{high2})	90/194
Oil Temperature Low (T_{low})	10/50

TECHNICAL DATA

Technical data

General	
Rotation speed, rpm	6
Transport speed max., km/h / mph	3/1,9
Angle of inclination, max.	30°

Hydraulic system	
Volume hydraulic system, l/gal	50/13
Pump type	Load sensing axial piston pump with variable displacement
Pump flow max.*, l/min /gal/min	65//17

Electric motor	
Type	Siemens 1LA9166-4LA66-Z
Power, kW	22
Speed, rpm	1455 (50 Hz) 1750 (60 Hz)
Voltage, V/frequency, Hz	380-420/50 440-480/60
Current, A	44

Control system	
Control type	Remote control
Signal transmission	Bluetooth/cable

Weight	
Without tool, kg / lb	1963/4328

Tools	
Rec. max. weight, kg / lb	230/507

Dimensions	
Length without tool, mm/in	2594/102
Width with track widener, mm/in	1110/44
Width without track widener, mm/in	780/31
Min. height, mm/in	1484/58
Clearance height, mm/in	185/7
Folding outrigger, mm/in	2056/81
Telescopic arm, mm/in	550/22
Caterpillar track width, mm/in	230/9
Work radius around the machine, mm/in	5200/205

*Maximum pump flow and system pressure cannot be taken out at the same time, the engine will be overloaded. 60 Hz has limited displacement.

TECHNICAL DATA

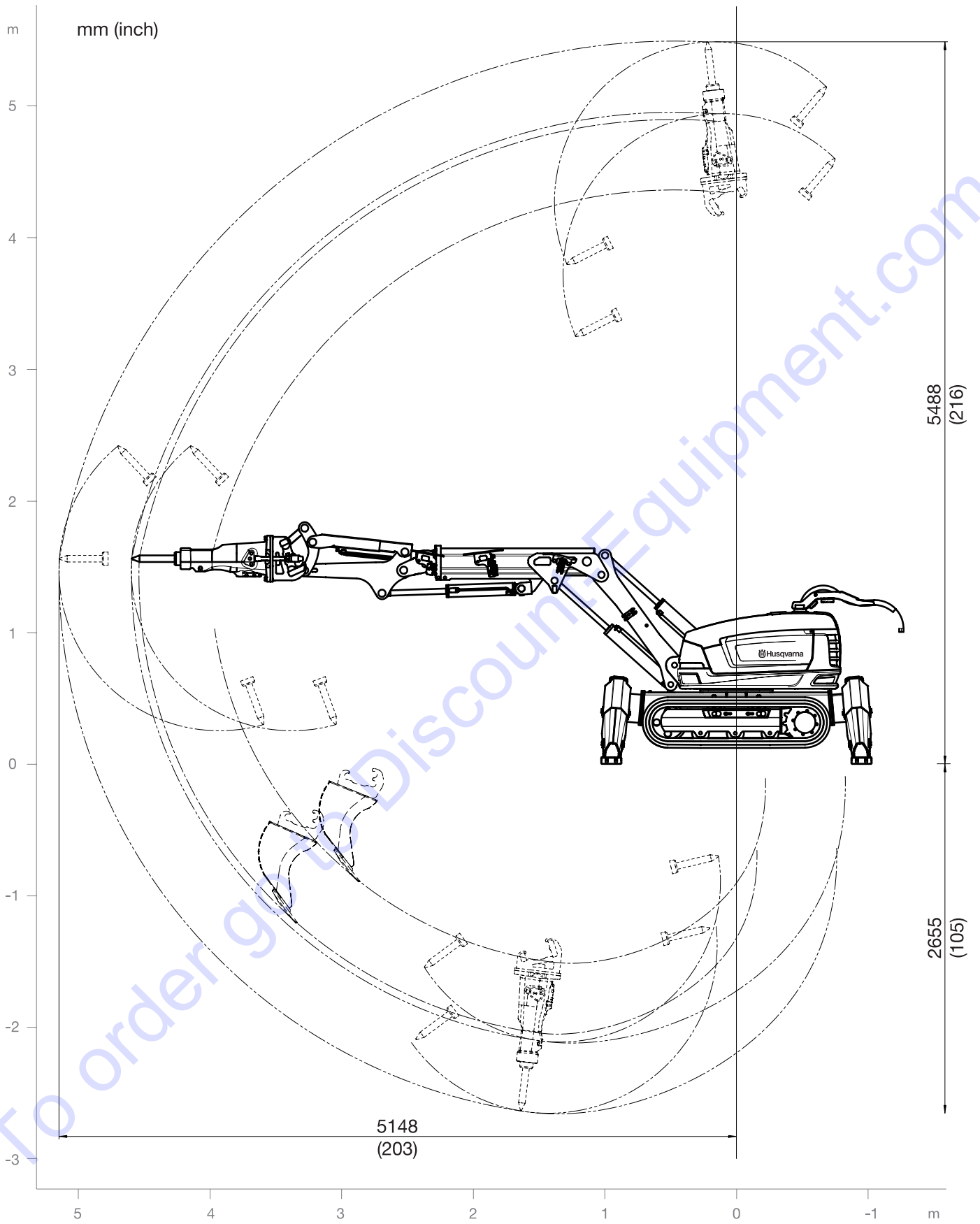

TECHNICAL DATA

mm (inch)

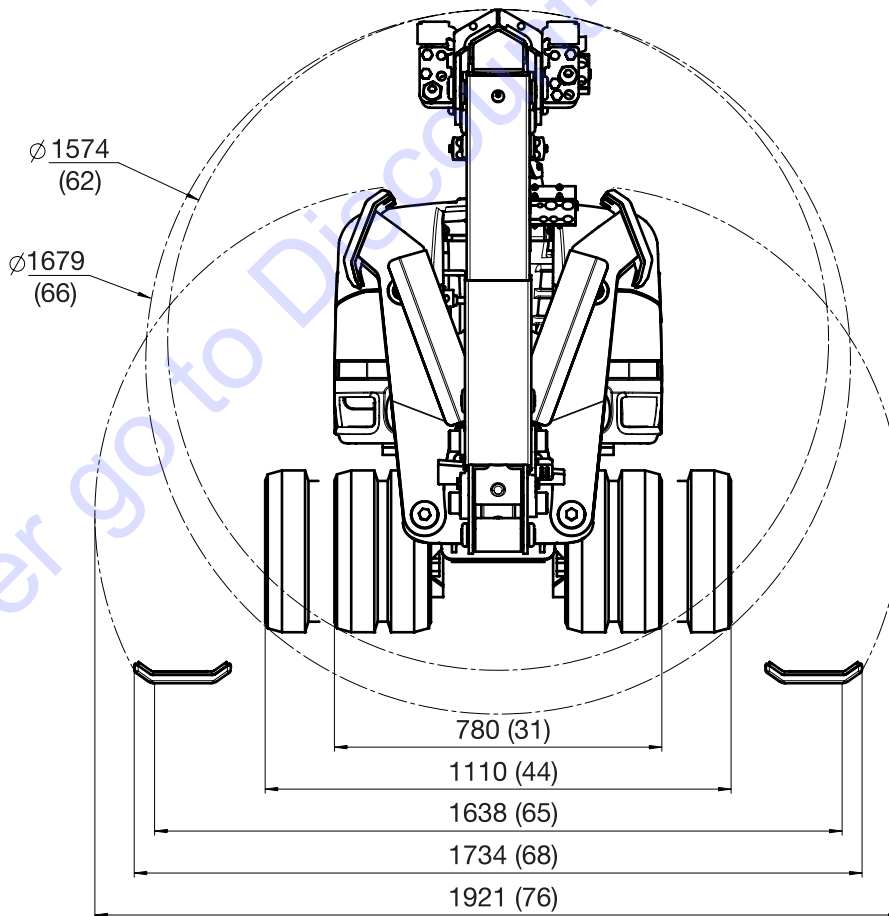
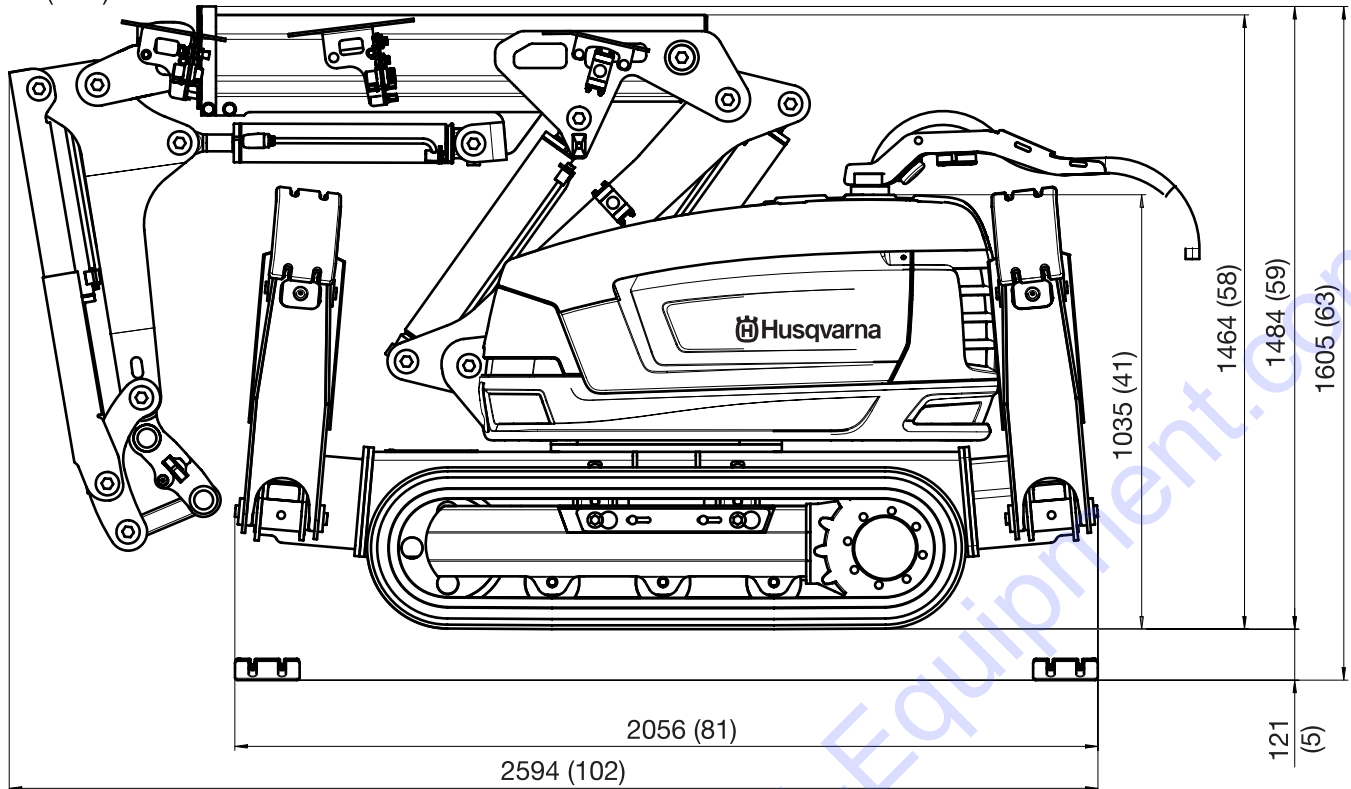



1151567-95

2009-03-16



TO PURCHASE THIS PRODUCT PLEASE CONTACT US



**Equipment Financing and
Extended Warranties Available**



**Discount-Equipment.com is your online resource for
commercial and industrial quality parts and equipment sales.**

561-964-4949

visit us on line @ www.discount-equipment.com

Select an option below to find your Equipment

Search by Manufacturer

Search by Product Type

Request a Quote

We sell worldwide for the brands: Genie, Terex, JLG, MultiQuip, Mikasa, Essick, Whiteman, Mayco, Toro Stone, Diamond Products, Generac Magnum, Airman, Haulotte, Barreto, Power Blanket, Nifty Lift, Atlas Copco, Chicago Pneumatic, Allmand, Miller Curber, Skyjack, Lull, Skytrak, Tsurumi, Husquvarna Target, Stow, Wacker, Sakai, Mi-T-M, Sullair, Basic, Dynapac, MBW, Weber, Bartell, Bennar Newman, Haulotte, Ditch Runner, Menegotti, Morrison, Contec, Buddy, Crown, Edco, Wyco, Bomag, Laymor, EZ Trench, Bil-Jax, F.S. Curtis, Gehl Pavers, Heli, Honda, ICS/PowerGrit, IHI, Partner, Imer, Clipper, MMD, Koshin, Rice, CH&E, General Equipment, Amida, Coleman, NAC, Gradall, Square Shooter, Kent, Stanley, Tamco, Toku, Hatz, Kohler, Robin, Wisconsin, Northrock, Oztec, Toker TK, Rol-Air, APT, Wylie, Ingersoll Rand / Doosan, Innovatech, Con X, Ammann, Mecalac, Makinex, Smith Surface Prep, Small Line, Wanco, Yanmar