



FSCURTIS

fscurtis.com

CA Series

AIR COMPRESSOR INSTALLATION AND OPERATING INSTRUCTION MANUAL

WARNING

Before installing and operating this compressor, read and understand the safety precautions contained in LV-474 supplement to and part of CAP-600

IMPORTANT

Make a permanent record of the Model and Serial number of your machine here. You'll save time and expense by including this reference identification on replacement part orders.

ChallengeAIR <small>CURTIS-TOLEDO, INC. 1905 Kienlen Avenue St. Louis, MO 63133</small>	
REFER TO MODEL & SERIAL NUMBER. READ INSTAL. & OPERATION INSTR. DO NOT OPERATE LOWER THAN 500 R.P.M. OR ABOVE MAX. AS STIPULATED BY PERFORMANCE DATA SHEET.	
MODEL NO.	SERIAL NO.
<input type="text"/>	<input type="text"/>

*CONSULT FACTORY FOR SPECIAL APPLICATIONS

CURTIS-TOLEDO, INC.

1905 Kienlen Avenue, St. Louis, Missouri 63133

phone: 314-383-1300 fax: 314-381-1439

email: info@curtistoledo.com

website: www.fscurtis.com

Sales representatives in principal cities

INSTALLATION

CONGRATULATIONS on your new Curtis Challenge Air Compressor. Please examine the compressor for shipping damage(s) and if any are found report it immediately to the carrier.

Select a clean dry location with a rigid floor strong enough to support the compressor. If the compressor is to be located in an area where vibration is critical, properly engineered vibration mounts and flexible piping should be used. Remove the skid. **NOTE: The compressor should never be operated on the shipping skid.** Level the compressor so it can be bolted down securely. Before tightening the bolts, check to see that all four feet are resting on the foundation. Shim as necessary to eliminate stress on the receiver or base when the bolts are tightened. We suggest using a level for proper alignment.

Maximum ambient temperature in which the compressor and motor should be operated is 104°F. Therefore, adequate ventilation must be provided.

The suction openings of the compressor are equipped with a combination air filter-muffler to protect the compressor from normal dust and other harmful substances. If the air around the compressor is excessively hot, dusty, humid or contaminated with foreign gases (such as ammonia or acid fumes) move the filter-muffler to a remote point where the air is clean, cool and dry. Run a pipe to the compressor suction opening. If the run is over 50 feet in length, use a larger pipe to avoid excessive pressure drop. In order to fit the filter to the compressor, bush down the connections. Be sure piping and fittings are clean and free from dirt and chips. If the filter is installed outside, check to insure that it is located above the normal outside dust level, and that rain cannot enter the filter element. Where the relocation of the filter-muffler is not possible or feasible, an oil bath filter is recommended and is available from Curtis.

On basic or base mounted compressors run a discharge pipe to the receiver or optional aftercooler and bush up or down as necessary. The pipe should enter near the top of the receiver. Keep in mind that condensate may form in the discharge line; therefore, the lines should always be pitched to drain condensate away from the compressor. Always provide a safety relief valve in the discharge line between the compressor and in-line shutoff valves. If more than one compressor pumps into a common system, a check valve in the discharge line of each compressor is recommended to prevent moisture from entering the cylinder head when one compressor is idle. A globe or gate valve installed in the discharge line will allow compressor isolation from plant air system for compressor maintenance. (Note: A safety relief valve should be located between the compressor and the globe/gate valve.)

Check the electrical supply for voltage, phase, and frequency to see that they match the nameplate stampings on the motor, magnetic starter, solenoids, and other controls. Use electrical wires of adequate size to carry the full load current of the motor without excessive voltage drop. Charts are available from Curtis (upon request) to provide information on this. The motor must always be protected by a starter with properly sized thermal overload(s). The starter should protect the motor from overheating and burnout due to an overload, low voltage or single phasing of a 3-phase circuit. **Failure to install the proper starter and overloads will void the motor manufacturers warranty.** Follow the National Electric Code or local electric code in providing wiring, fusing and disconnect switches. **NOTE: Do not close the disconnect switch to start the compressor until the procedures outlined under "Startup Procedures" have been completed.**

LIMITED SAFETY PRECAUTIONS

(Also see supplement LV-474)

The following safety precautions are recommended in the use of this compressor:

1. Use a totally enclosed OSHA-approved belt guard to cover the drive assembly. Where possible, place the flywheel toward the wall, and mount the unit a minimum distance of 2 feet from the wall for maintenance convenience.
2. Turn off & lock out the electrical disconnect switch before working on the unit to prevent the unit from starting unexpectedly
3. Release all air pressure from the system before working on the unit and red tag all electrical control switches, for safety precaution.
4. Do not by-pass motor over-current protection.
5. Do not change the setting or in any way affect the operation of the safety valve.
6. Keep unit securely anchored so that movement will not put a strain on piping, wiring, or air receiver.

WARNING: Read and understand supplement LV-474 before installing and operating the compressor.

START-UP PROCEDURES

OIL RECOMMENDATION

Use Genuine **CURTISLUBEPLUS** Lubricants. Specially formulated for Curtis Reciprocating Air Compressors. Non-Detergent type with anti-foam, anti-rust and oxidation inhibitors.

Recommended **ISO68 RC-1000** Premium Reciprocating Compressor Lubricant, **Part no. VO411-3**, 12-quart case or VO411-2, 4 gallon case.

Recommended **ISO100 RC-1000A** Premium Reciprocating Compressor Lubricant **Part no. VO421-3**, 12-quart case or VO421-2, 4 gallon case.

CURTISLUBEPLUS Lubricants are available through your authorized Curtis distributor.

If the compressor is equipped with an automatic start-stop control (with pressure switch unloading), it is automatically unloaded upon starting, and will automatically load after attaining running speed. If the compressor is equipped with a constant speed control (pilot valve unloading), it is necessary to manually unload the compressor, if there is pressure in the discharge line, in order to achieve an unloaded start. The compressor must be manually loaded after the compressor has attained full running speed, there after, it functions automatically to maintain operating pressure until the unit is shut off.

Close the disconnect switch and start the compressor. Observe the direction of rotation, which should be counterclockwise when viewed from the flywheel side of the compressor on all models. For single-phase units, the direction of rotation is determined by the motor nameplate instructions, and is adjusted at the factory. For three-phase units, if the rotation is incorrect, stop the unit and interchange any two of the three wires to the motor at the disconnect switch. This will reverse the direction of rotation of the motor and compressor.

PREVENTIVE MAINTENANCE

A good maintenance program will add years of service to your air compressor. The following is recommended as a minimum maintenance program. (TURN OFF POWER BEFORE SERVICING.)

LUBRICATION

- For proper lubrication the compressor shall not be operated below the minimum or above the maximum R. P.M. recommended for the various models.
- Maintain oil level mid-way between the upper and lower lines of the crankcase sight gage. **NOTE ILLUSTRATION:**

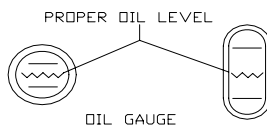

- Stop compressor to add and gauge oil.
- Do not fill above the upper line and do not operate compressor with oil level below the lower line.

DO NOT OVER FILL

- Change oil at the first 100 hours of operation and 1000 hours thereafter, or as required. It may be necessary to change oil more frequent due to abnormal humid and contaminated conditions.

DAILY MAINTENANCE

- Check and maintain oil level at centerline of sight glass and add oil as necessary.
- Drain condensate from receiver unless it is equipped with an automatic tank drain, in which case the drain should be checked weekly to see that it is operating. See automatic tank drain instructions.

WARNING: Read and understand supplement LV-474 before installing and operating the compressor.

- Check for unusual noise or vibration (See "Trouble Shooting".)

WEEKLY MAINTENANCE

- Clean the air filters. A clogged air filter can seriously affect the efficiency of the compressor and cause overheating and oil usage.
- Clean all external parts of the compressor and driver. Be sure to clean the intercooler-finned surface on two-stage compressors. A dirty compressor will cause abnormally high discharge temperature and resulting oil carbonization on internal valve components
- Check the safety valve manually (by pulling ring or lever) to see that it is not stuck.

MONTHLY MAINTENANCE

- Inspect the entire air system for leaks.
- Inspect condition of oil and change if necessary.
- Check drive belt tension and tighten if needed.

EVERY 3 MOS. OR 1,000 HRS. OF OPERATION

- Change oil.
- Inspect valves. Clean the carbon from valves and head if necessary.
- Check and tighten if necessary all bolts, nuts, etc.
- Check unloader operation.

*CHECKING BELT TENSION

The v-belt(s) should be adjusted so that a declination of about 3/8 – 1/2 inch will be obtained when it is pushed by a finger at the middle point as shown in Figure 1.

CAUTION: Over tightening the v-belt(s) will result in overloading of the motor and belt failure, while a loose belt will be slipping and resulting in an unstable speed, overheating the belt and high amp draw.

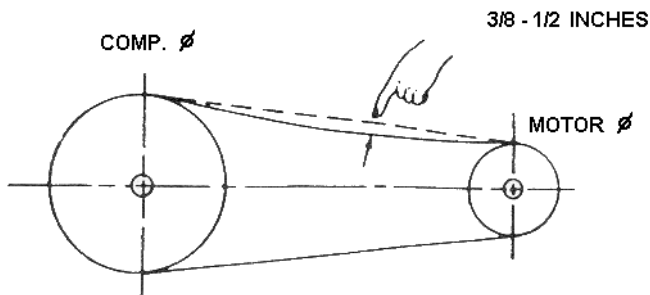

Figure 1

To change tension, loosen the motor hold-down bolts and slide the motor on the base, using a lever if necessary, or by turning the adjusting bolt at the end of the base.

Retighten motor hold-down bolts.

NOTE: Do not over tighten belts.

ELECTRIC MOTOR

Grease once a year with a good grade of lithium ball bearing grease, or as directed by the motor manufacturer.

VALVE INSPECTION AND MAINTENANCE

Valves should be inspected at regular intervals as recommended under "Maintenance" and cleaned or replaced when necessary. The valve can be serviced without disconnecting air piping or removing the head.

(Be sure the power to the motor is disconnected and all pressure released before starting to work on the compressor.)

On constant run models, it is necessary to remove the unloader piping before the valve plugs can be removed.

MODELS E-11 AND E-23 (Figures 2 and 3)

A. Disassembly:

1. Unbolt the outlet valve push cover (70112-11450).
2. Remove the outlet valve push cover packing (70112-11650), spring (70112-41070) and valve plate (70112-31030). **CAUTION: Steps 1 and 2 are for outlet valve.**
3. Remove the unloading connecting tube for Models E-11 and E-23.
4. Untighten four cylinder head fixed bolts.
5. Remove cylinder head carefully and turn it over.
6. Unbolt inlet valve receiver (70112-31020).
7. Remove valve spring (70112-31070) and valve plate (70112-31030).

Valves should be inspected approximately every 1,000 hours of operation. Inspect the valve seats on cylinder head for dents, cracks or wear. Replace all defective parts. Remove carbon deposits and wash all valve components in a suitable non-flammable cleaning fluid.

B. Assembly:

1. Place outlet valve plate (70112-31030) in position.
2. Place the outlet valve push cover packing (70112-11650) in position.
3. Insert the spring (70112-41070) into outlet valve push cover (70112-11450).
4. Turn outlet valve push cover (70112-11450) in position carefully.

5. Check the valves to see if they can move freely in their guides.
6. Turn over the cylinder head (70112-11010).
7. Place the inlet valve plate (70112-31030) in position.
8. Insert the small end of inlet valve spring (70112-31070) into position of valve receiver (70112-31020).
9. Screw inlet valve receiver in position.
10. Check the valves to see if they can move freely in their guides and do not pinch or bind between the seat and guard legs.

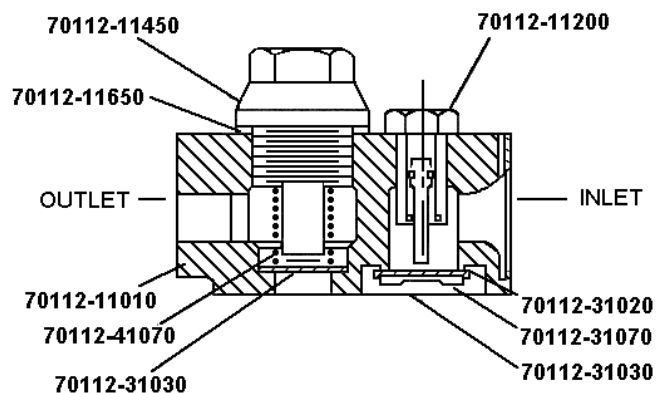

Figure 2

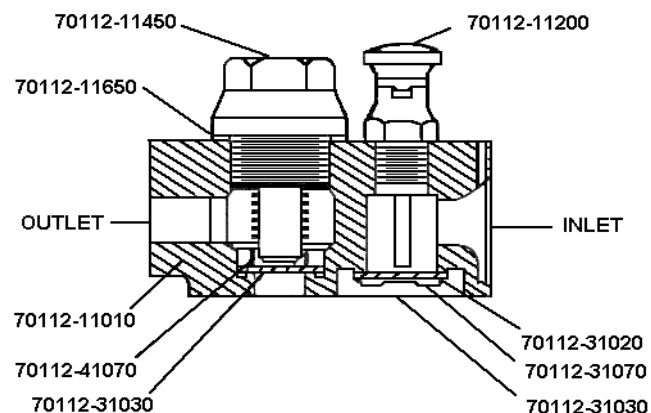

Figure 3

WARNING: Read and understand supplement LV-474 before installing and operating the compressor.

MODELS E-50, E-71 AND E-15 (Figures 4 and 5)**A. Disassembly of Inlet Valve Assembly (Figure 4).**

1. Untighten the hex nut.
2. Remove unloading fork (70123-31080), unloading fork guide (70123-31090), unloading spring (70123-11230) and valve seat (70123-31010).

CAUTION:

1. If a vise is used to hold the valve assembly, be careful not to clamp the assembly too tight.
2. Valve assembly should be inspected approximately every 1,000 hours of operation.
3. Inspect the valve seat for dents, cracks or wear.
4. Replace all defective parts.
5. Valve seats that might be worn after years of operation can be re-lapped or re-ground, in this case the recess in which the valve guard legs fit must also be cut down accordingly to ensure a same valve lift.
6. Remove carbon deposits and wash all valve components in a suitable non-flammable cleaning fluid.

B. Reassembly of Inlet Valve Assembly

1. Place valve spring (70123-31070) and valve plate (70123-31030) on valve receiver (70123-31020).
2. Place valve seat (70123-31010), unloading fork guide (70123-31090), unloading spring (70123-11230) and unloading fork (70123-31080) respectively.
3. Tighten the valve assembly by tightening the hex nut.
4. Check the valves to see if they can move freely in their guides and do not pinch or bind between the seat and guard legs.

C. Disassembly of Outlet Valve Assembly (Figure 5)

1. Untighten the hex nuts.
2. Remove valve receiver (70123-41020), valve spring (70123-41070) and valve plate (70123-31030).

CAUTION: Refer to disassembly of inlet valve assembly (paragraph B).

D. Reassembly of Outlet Valve Assembly

1. Place valve spring (70123-41070) in valve receiver (70123-41020).
2. Place valve plate (70123-31030) in valve receiver (70123-41020).
3. Insert the sub-assembled part (assembled in step 1 and 2) into valve seat (70123-41010).
4. Tighten the hex nuts.
5. Check the valves to see if they can move freely in their guides and do not pinch or bind between the seat and guard legs.

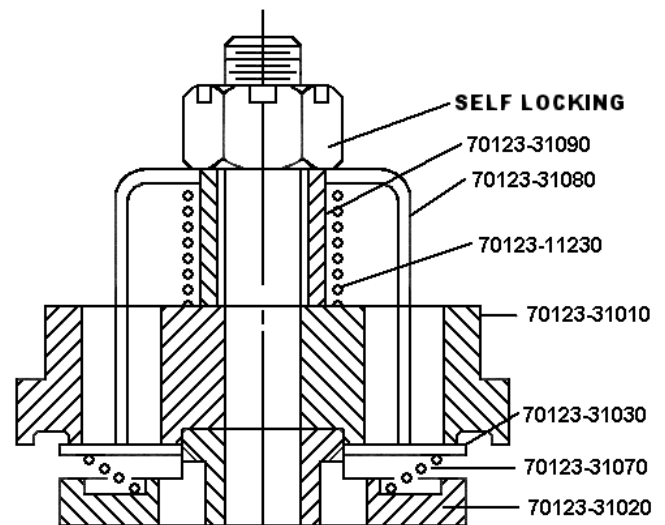
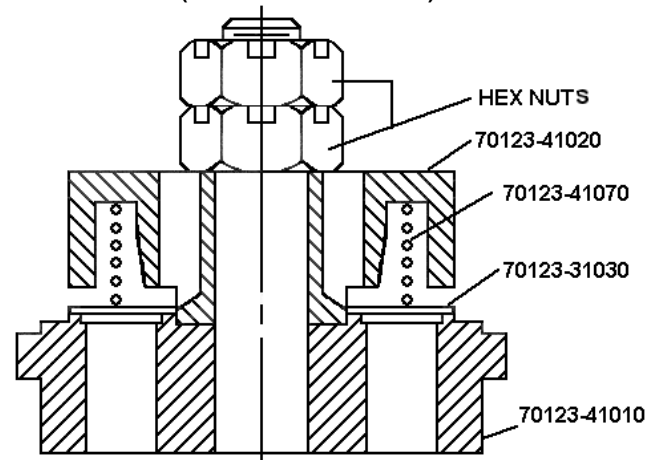
**FIGURE 4 (EXAMPLE SHOWN E-50)****FIGURE 5 (EXAMPLE SHOWN E-50)**

WARNING: Read and understand supplement LV-474 before installing and operating the compressor.

VALVE ASSEMBLY INSTALLATION - E-50 MODEL

(Figures 6 and 7)

1. Install valve assembly gasket (70123-11110)
2. Install valve assembly (70123-31000).
3. Install valve push cover (70123-11150).
4. Install head bolt and tighten evenly and securely.

It is strongly recommended that a Preventative Maintenance Kit & Valve/Gasket Maintenance Kit be kept on hand. In this manner, the valves can be used in turn to keep the compressor always in good condition and a minimum downtime.

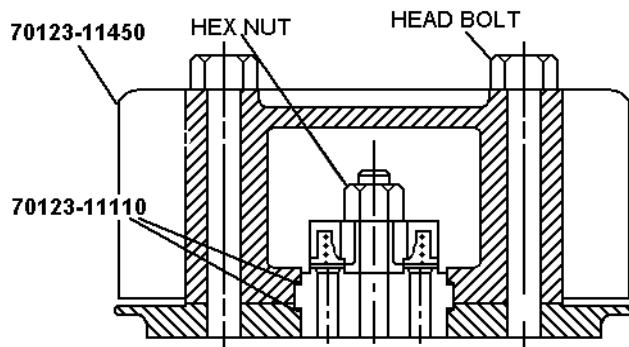

FIGURE 6

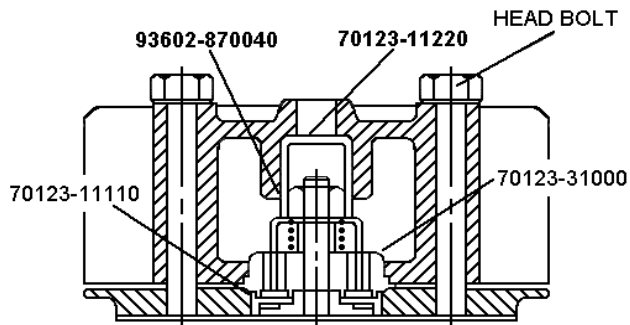

FIGURE 7

PISTON RINGS (Rebuild Kit)

To inspect or replace piston rings as follows:

1. Remove cylinder head.
2. Remove cylinder.
3. Loosen the connecting rod bolts.
4. Push out the piston with piston rings and connecting rod.
5. To remove the old rings, pry them out of their grooves and slide them over the piston. Care should be taken not to damage the piston.
6. Inspect the ring grooves for nicks and carbon deposits. Clean the ring grooves and remove the obstructions, which might prevent the rings from moving freely.

To install new rings on the piston as follows: (Be careful not to damage the piston and rings).

1. Install the oil control ring (70123-61050) first. Rotate ring in groove to make sure it is free.
2. Install the Compression ring (70123-61030). Make sure the "top" or "R" mark is exactly on top. If not, it might cause excessive oil consumption.
3. Repeat the process with other rings, if any.
4. Assemble connecting rod into the crankshaft. Be sure that the connecting rod and its cap are in original pair and position, since the connecting rod cap and crankshaft pin bushing are selected fitted and are not interchangeable.
5. Check if the ring gaps are in proper positions (Figure 8).

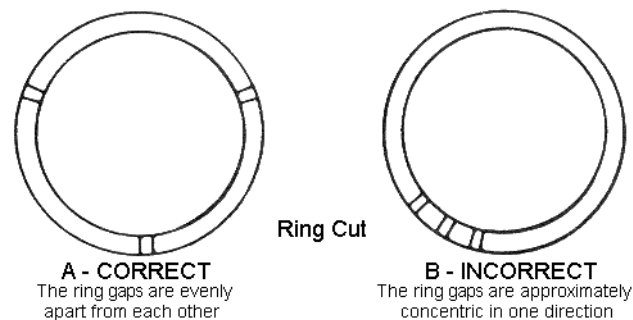

FIGURE 8

WARNING: Read and understand supplement LV-474 before installing and operating the compressor.

• REBUILD KITS

AIR COOLED SINGLE STAGE MODELS

ES03

PART NO.	CONSISTS OF:	
CF1299	1	70111-66140 Filter Element
	2	70111-31030 Valve Disc
	1	70111-31070 Spring
	1	70111-41070 Spring
	1	70111-11461 Gasket
	1	70111-11612 Head Gasket
	2	70111-61030 Comp. Ring
	1	70111-61050 Oil Ring
	1	70111-57970 Bottom Cover Gasket
	1	70111-57950 Front bearing cover gasket
1	70111-57080 Front Oil Seal	
1	70111-57960 Rear Cover Gasket	
10	92521-190600 Copper Washer	

ES05

PART NO.	CONSISTS OF:	
CF1237	1	70111-66140 Filter Element
	2	70112-31030 Valve Disc
	1	70112-31070 Spring
	1	70112-41070 Spring
	2	70112-61030 Comp. Ring
	1	70112-61050 Oil Ring
	1	70112-11612 Head Gasket
	1	70112-51610 Crankcase Gasket
	1	70112-57950 Front Cover Gasket
	1	70112-57960 Rear Cover Gasket
	1	70112-57080 Oil Seal
	12	92521-190800 Copper Washer
	1	70112-11461 Copper Gasket

ES06

ES10, ES10P

ES20

PART NO.	CONSISTS OF:		PART NO.	CONSISTS OF:		PART NO.	CONSISTS OF:	
CF1302	2	70111-66140 Filter Element	CF1238	2	70111-66140 Filter Element	CF1239	3	70111-66140 Filter Element
	4	70111-31030 Valve Disc		4	70112-31030 Disc		6	70112-31030 Disc
	2	70111-31070 Spring		2	70112-31070 Spring		3	70112-31070 Spring
	2	70111-41070 Spring		2	70112-41070 Spring		3	70112-41070 Spring
	2	70111-11461 Gasket		4	70112-61030 Compression Ring		6	70112-61030 Compression Ring
	2	70111-11612 Head Gasket		2	70112-61050 Oil Ring		3	70112-61050 Oil Ring
	2	70121-51610 Crankcase Gasket		2	70112-11612 Head Gasket		3	70112-11612 Head Gasket
	4	70111-61030 Comp. Ring		2	70112-51610 Crankcase Gasket		3	70112-51610 Crankcase Gasket
	2	70111-61050 Oil Ring		1	70122-57950 Front Cover Gasket		1	70122-57950 Front Cover Gasket
	1	70121-57950 Front Cover Gasket		1	70122-57960 Rear Cover Gasket		1	70122-57960 Rear Cover Gasket
	1	70111-57960 Rear Cover Gasket		1	70122-57080 Front Oil Seal		1	70122-57080 Front Oil Seal
	1	70121-57970 Bottom Cover Gasket		24	92521-190800 Copper Washer		26	92521-190800 Copper Washer
	24	92521-190600 Copper Washer		2	70112-11461 Copper Gasket		3	70112-11461 Copper Gasket

ES-30

ES-50

ES-100

ES-150

ES-150A

PART NO.	CONSISTS OF:		PART NO.	CONSISTS OF:		PART NO.	CONSISTS OF:		PART NO.	CONSISTS OF:		PART NO.	CONSISTS OF:	
CF1246	REBUILD KIT INCLUDES:		CF1252	REBUILD KIT INCLUDES:		CF1252	REBUILD KIT INCLUDES:		CF1252	REBUILD KIT INCLUDES:		CF1252	REBUILD KIT INCLUDES:	
	2	70123-66140 Filter Kit		3	70123-66140 Filter Element		3	70123-66140 Filter Element		3	70123-66140 Filter Element			
	4	70123-31030 Disc		3	70123-31070 Spring		3	70123-31070 Spring		3	70123-31070 Spring			
	2	70123-41070 Spring		3	70123-41070 Spring		3	70123-41070 Spring		3	70123-41070 Spring			
	4	70123-61030 Compression Ring		6	70123-31030 Disc		6	70123-31030 Disc		6	70123-31030 Disc			
	4	70123-61050 Oil Ring		3	70123-31070 Spring		3	70123-31070 Spring		3	70123-31070 Spring			
	4	70123-11110 Seat Gasket		3	70123-41070 Spring		3	70124-41070 Spring		9	70125-41074 Spring			
	2	70123-11612 Head Gasket		6	70123-11110 Seat Gasket		6	70124-11110 Seat Gasket		6	70125-11110 Seat Gasket			
	2	70123-51610 Crankcase Gasket		3	70123-11612 Head Gasket		3	70124-11612 Head Gasket		3	70125-87510 Manifold Gasket			
	1	70123-57950 Front Cover Gasket		3	70123-11612 Head Gasket		3	70125-11610 Head Gasket		3	70125-41030 Disc O / V			
	1	70123-57960-01 Rear Cover Gasket								**	70125-11612 Head Gasket			
	1	70123-57080 Front Oil Seal												
	*2	70123-61081 Bushing												
	2	70123-61090 Set, Rod Bearing												
26	92521-191000 Copper Washer													

* **WARNING** – THESE ITEMS INTERCHANGE WITH PARTS ON SERIAL #3020000 & HIGHER ONLY. CONTACT FACTORY FOR EARLIER SERIES.

** USE WITH SERIAL #A311XXXX AND LATER. 70135-11610 REPLACES 70125-11610

• REBUILD KITS

AIR COOLED TWO STAGE MODELS

E-35

E-11			E-23		
PART NO.	CONSISTS OF:		PART NO.	CONSISTS OF:	
CF1250	1	70111-66140 Filter Element	CF1251	2	70111-66140 Filter Element
	2	70112-31030 Disc		4	70112-31030 Disc
	2	70162-32030 Disc		2	70111-31030 Disc
	1	70112-31070 Spring		2	70112-31070 Spring
	1	70162-42070 Spring		2	70112-41070 Spring
	1	70112-41070 Spring		1	70172-32070 Spring
	1	70162-32070 Spring		1	70172-42070 Spring
	2	70112-61030 Compression Ring		4	70112-61030 Compression Ring
	1	70112-61050 Oil Ring		2	70112-61050 Oil Ring
	2	70162-62030 Compression Ring		2	70111-61030 Compression Ring
	2	70162-62050 Oil Ring		2	70111-61050 Oil Ring
	1	70112-11612 Head Gasket (1 st)		2	70112-11612 Head Gasket (1 st)
	1	70162-12610 Head Gasket (2 nd)		1	70111-11612 Head Gasket (2 nd)
	2	70112-51610 Crankcase Gasket		3	70112-51610 Crankcase Gasket
	1	70122-57950 Front Cover Gasket		1	70122-57950 Front Cover Gasket
	1	70122-57960 Rear Cover Gasket		1	70122-57960 Rear Cover Gasket
	1	70122-57080 Front Oil Seal		1	70122-57080 Front Oil Seal
24	92521-190800 Copper Washer	32	92521-190800 Copper Washer		
1	70112-11461 Copper Gasket	1	70111-11461 Copper Gasket		
		2	70112-11461 Copper Gasket		

PART NO.	CONSISTS OF:	
CF1306	PREVENTATIVE MAINTENANCE KIT INCLUDES:	
	1	70152-66141 Element
CF1307	VALVE/GASKET MAINT KIT INCLUDES:	
	4	70152-31030 Disc
	2	70152-32030 Disc
	4	70152-31070 Spring
	2	70152-32070 Spring
	1	70152-11612 Head Gasket
1	70152-31120 Seat Gasket	
1	70152-11622 Seat Gasket	
CF1308	REBUILD KIT INCLUDES:	
	1	70152-51610 Case Gasket
	1	70152-57960 Rear Cover Gasket
	2	70152-61030 Comp. Ring
	1	70152-61050 Oil Ring
	1	70152-61080 Bushing (L.P.)
	1	70152-62080 Bushing (H.P.)
	2	70152-61090 Rod Bearing Set
	3	70152-62030 Compression Ring
	1	70152-62050 Oil Ring
	1	70152-57950 Front Cover Gasket
	1	70127-57080 Front Oil Seal
6	92521-190800 Copper Washer	

E-57			E-50			E-71			E-15		
PART NO.	CONSISTS OF:		PART NO.	CONSISTS OF:		PART NO.	CONSISTS OF:		PART NO.	CONSISTS OF:	
CF1291	PREVENTATIVE MAINTENANCE KIT INCLUDES:		CF1315	PREVENTATIVE MAINTENANCE KIT INCLUDES:		CF1315	PREVENTATIVE MAINTENANCE KIT INCLUDES:		CF1315	PREVENTATIVE MAINTENANCE KIT INCLUDES:	
	1	70153-66142 Element		2	70123-66140 Element		2	70123-66140 Element		2	70123-66140 Element
CF1292	VALVE/GASKET MAINT KIT INCLUDES:		CF1253	VALVE/GASKET MAINT KIT INCLUDES:		CF1255	VALVE/GASKET MAINT KIT INCLUDES:		CF1257	VALVE/GASKET MAINT KIT INCLUDES:	
	4	70153-31032 Disc		6	70123-31030 Disc		4	70124-31030 Disc		4	70125-31030 Disc
	2	70153-32032 Disc		3	70123-31070 Spring		2	70123-31030 Disc		2	70175-42030 Disc
	4	70153-31072 Spring		3	70123-41070 Spring		2	70124-31070 Spring		2	70125-31070 Spring
	2	70153-32072 Spring		6	70123-11110 Seat Gasket		1	70123-31070 Spring		1	70124-31070 Spring
	1	70153-31120 Head Gasket		3	70123-11612 Head Gasket		2	70124-41070 Spring		6	70125-41070 Spring
	1	70153-11612 Seat Gasket					1	70123-41070 Spring		1	70124-41072 Spring
	1	70153-11622 Seat Gasket					4	70124-11110 Seat Gasket		4	70125-11110 Seat Gasket
CF1293	REBUILD KIT INCLUDES:		CF1254	REBUILD KIT INCLUDES:		CF1256	REBUILD KIT INCLUDES:		CF1258	REBUILD KIT INCLUDES:	
	1	70153-57951 Front Bearing Gasket		1	70123-57950 Front Bearing Gasket		1	70124-57950 Front Bearing Gasket		4	70125-61030 Compression Ring
	2	70124-61030 Compression Ring		4	70123-61030 Compression Ring		4	70124-61030 Compression Ring		4	70125-61050 Oil Ring
	2	70124-61050 Oil Ring		4	70123-61050 Oil Rings		4	70124-61050 Oil Ring		3	70124-61030 Compression Ring
	3	70153-62030 Compression Ring		3	70112-61030 Compression Ring		3	70123-61030 Compression Ring		2	70124-61050 Oil Ring
	1	70153-62050 Oil Ring		1	70112-61050 Oil Ring		2	70123-61050 Oil Ring		2	70125-61081 Bushing
	1	70153-61081 Bushing (L.P.)		2	70123-61081 Bushing		2	70124-61080 Bushing		3	70125-61090 Rod Bearing (2 Halves)
	1	70153-62081 Bushing (H.P.)		1	93503TA1725 Needle Bearing		1	70174-62081 Bushing		3	70135-51610 Gasket
	4	70153-61090 Rod Bearing (Halves)		6	70123-61090 Rod Bearing (Halves)		3	70124-51610 Gasket		1	70134-57080 Oil Seal
	1	70153-51611 Case Gasket		3	70123-51610 Crankcase Gasket		1	70134-57080 Oil Seal		1	70135-57950 Front Bearing Gasket
	1	70123-57080 Oil Seal		1	70123-57080 Oil Seal		6	70124-61090 Bearing (Halves)		1	70134-57960 Rear Bearing Gasket
	1	70153-57961 Rear Bearing Gasket		1	70133-57960 Rear Bearing Gasket		1	70134-57960 Rear Bearing Gasket		24	92521-191200 Copper Washer
26	92521-191000 Copper Washer	34	92521-191000 Copper Washer	34	92521-191000 Copper Washer	1	93503-NK28/30 Needle Bearing ***				
		1	70173-62080 Bushing			1	70175-62080 Bushing ****				

* **WARNING** – THESE ITEMS INTERCHANGE WITH PARTS ON SERIAL #3020000 & HIGHER ONLY. CONTACT FACTORY FOR EARLIER SERIES.

** USE WITH SERIAL #A311XXXX AND LATER. 70135-11610 REPLACES 70125-11610

*** USE WITH SERIAL #A409XXXX AND LATER

**** USE FOR UNITS PRIOR TO SERIAL #A409XXXX

RING SETS & GASKET SETS

SINGLE STAGE

MODEL	PART NO.	DESCRIPTION	QUANTITY REQ'D
ES03	CF1297	Ring set	1
	CF1298	Gasket set	1
ES05	CF1259	Ring set	1
	CF1276	Gasket set	1
ES06	CF1300	Ring set	2
	CF1301	Gasket set	1
ES10	CF1260	Ring set	2
	CF1277	Gasket set	1
ES20	CF1261	Ring set	3
	CF1278	Gasket set	1
ES30	CF1262	Ring set	2
	CF1279	Gasket set	1
ES50	CF1263	Ring set	3
	CF1280	Gasket set	1
ES100	CF1264	Ring set	3
	CF1281	Gasket set	1
ES150 & ES150A	CF1265	Ring set	3
	CF1282	Gasket set	1
	*CF1311	*Gasket set	1

TWO-STAGE

MODEL	PART NO.	DESCRIPTION	QUANTITY REQ'D
E11	CF1266	Ring set (LP)	1
	CF1267	Ring set (HP)	1
	CF1283	Gasket set	1
E23	CF1268	Ring set (LP)	2
	CF1269	Ring set (HP)	1
	CF1284	Gasket set	1
E35	CF1303	Ring set(LP)	1
	CF1304	Ring set(HP)	1
	CF1305	Gasket set	1
E50	CF1270	Ring set(LP)	2
	CF1271	Ring set(HP)	1
	CF1285	Gasket set	1
E57	CF1288	Ring set(LP)	1
	CF1289	Ring set(HP)	1
	CF1290	Gasket set	1
E71	CF1272	Ring set(LP)	2
	CF1273	Ring set(HP)	1
	CF1286	Gasket set	1
E15	CF1274	Ring set(LP)	2
	CF1275	Ring set(HP)	1
	CF1287	Gasket set	1
	*CF1313	*Gasket set	1

* USE WITH SERIAL #A311XXXX AND LATER

MODEL ES-03 AIR COOLED, SINGLE STAGE, SINGLE CYLINDER

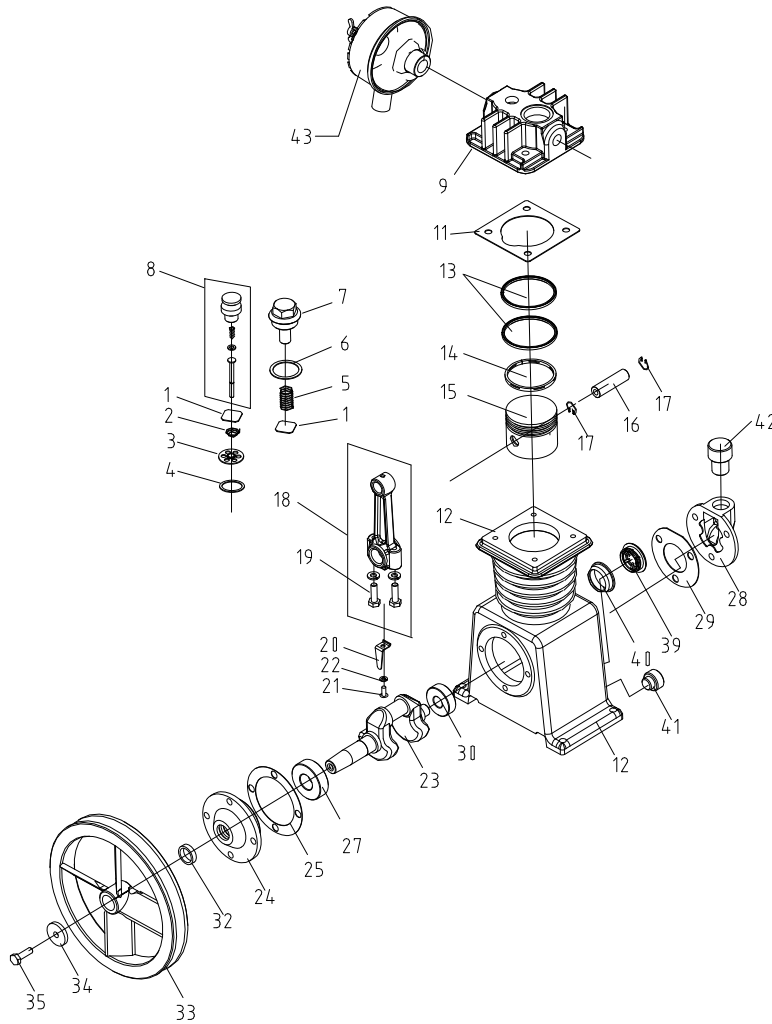

Description	QTY	PART NO.
VALVES		
1. Inlet & Outlet Valve Plate	2	70111-31030
2. Inlet Valve Spring	1	70111-31070
3. Inlet Valve Receiver	1	70111-31020
4. Inlet Valve Snap Ring	1	93610-130225
5. Outlet Valve Spring	1	70111-41070
6. Outlet Valve Push Cover Gasket	1	70111-11461
7. Outlet Valve Push Cover	1	70111-11450
8. Manual Unloader Assembly	1	70111-11300
CYLINDERS		
9A. Cylinder Head Assembly (Includes Valves)	1	70111-11000-4024
9B. Cylinder Head (Bare Casting)	1	70111-11010
10. Cylinder Head Bolt (Not Shown)	4	(Hardware Item)
11. Cylinder Head Gasket	1	70111-11612
12. Cylinder & Crankcase	1	70111-57010-4024
13. Compression Ring	2	70111-61030
14. Oil Control Ring	1	70111-61050
15. Piston	1	70111-61011
16. Piston Pin	1	70111-61120
17. Piston Pin Snap Ring	2	70111-61070
18. Connecting Rod Assembly	1	70111-61200
19. Connecting Rod Bolt	2	(furnished on conn. Rod only)
20. Oil Splash Dipper	1	70111-61282
21. Oil Splash Dipper Bolt	1	91507-2304010
22. Oil Splash Dipper Bolt Washer (Not Shown)	1	92522-130400

Description	QTY	PART NO.
CRANKCASE AND CRANK ASSEMBLY		
23. Crankshaft	1	70111-56010
24. Front Bearing Cover	1	70111-57030
25. Front Bearing Cover Gasket	1	70111-57950
26. Front Cover Bolts (Not Shown)	4	91501-1306016
27. Front Bearing #6203	1	93501-6203
28. Rear Bearing Cover	1	70111-57060
29. Rear Bearing Cover Gasket	1	70111-57960
30. Rear Bearing #6201	1	93501-6201
31. Rear Bearing Cover Bolts (Not Shown)	3	93501-1306016
32. Front Oil Seal	1	70111-57080
33. Compressor Pulley	1	70111-76010
34. Compressor Pulley Thrust Washer	1	70111-76210
35. Compressor Pulley Thrust Bolt	1	91501-1306020
36. Crankcase Bottom Cover (Not Shown)	1	70111-57220
37. Crankcase Bottom Cover Gasket (Not Shown)	1	70111-57970
38. Compressor Pulley Pin	NA	(Not Required)
39. Oil Level Gauge And Cover	1	70111-57700
40. Gauge Cover Seal	1	70111-57730
41. Crankcase Oil Plug (1/4" PT)	1	90112-100202
42. Breather Assembly	1	70191-57600-4024
AIR STRAINER ELEMENT		
43. Air Strainer Assembly	1	70111-66001
44. Air Strainer Element (Not Shown)	1	70111-66140

CRANKCASE AND CRANK ASSEMBLY

MODEL ES-06

AIR COOLED, SINGLE STAGE, TWO CYLINDER

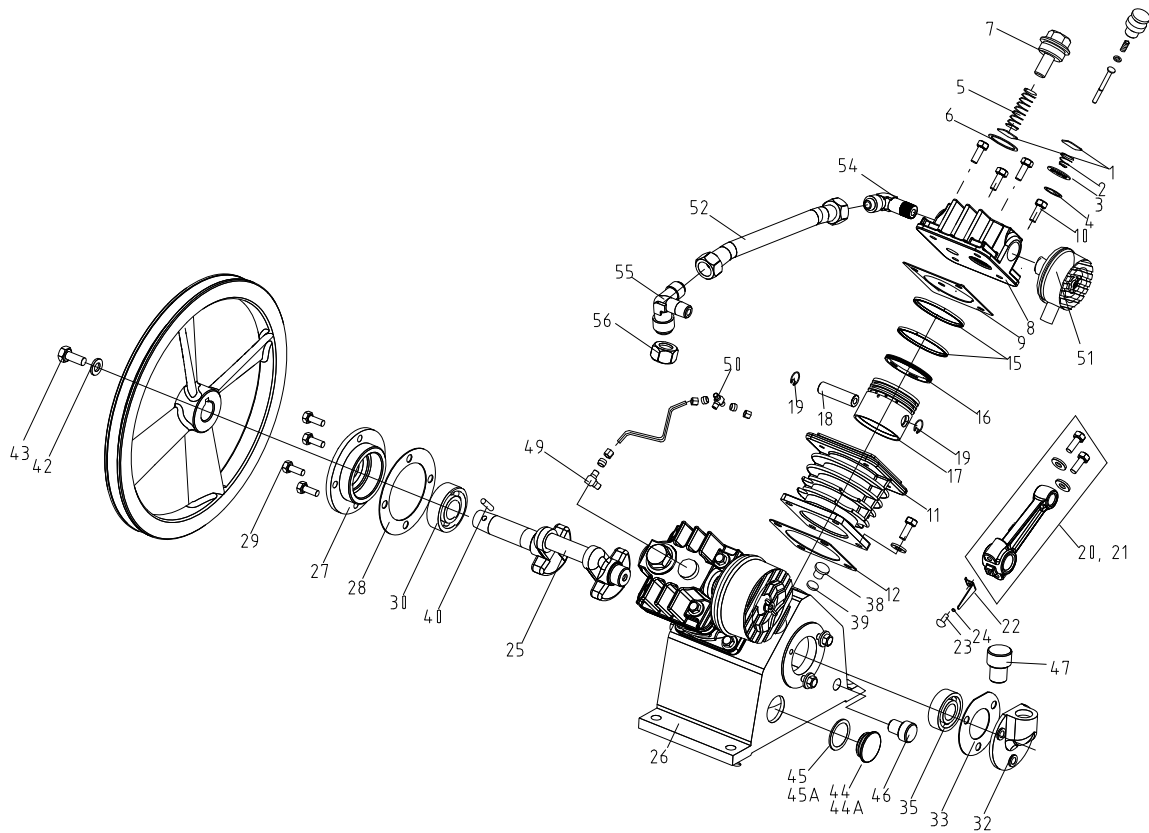

DESCRIPTION	QTY	PART NO.	DESCRIPTION	QTY	PART NO.	
VALVES			28	Front Bearing Cover Gasket	1	70121-57950
1. Inlet And Outlet Valve Plate	4	70111-31030	29	Front Bearing Cover Bolt	4	91501-1306016
2. Inlet Valve Spring	2	70111-31070	30	Front Bearing #6204	1	93501-6204
3. Inlet Valve Receiver	2	70111-31020	32	Rear Bearing Cover	1	70111-57060
4. Inlet Valve Snap Ring	2	93610-130225	33	Rear Bearing Cover Gasket	1	70111-57960
5. Outlet Valve Spring	2	70111-41070	34	Rear Bearing Cover Bolt (Not Shown)	3	91501-1306016
6. Outlet Valve Push Cover Gasket	2	70111-11461	35	Rear Bearing #6203	1	93501-6203
7. Outlet Valve Push Cover	2	70111-11450	36	Crankcase Bottom Cover (Not Shown)	1	70121-57220
			37	Crankcase Bottom Cover Bolt (Not Shown)	1	70121-57970
CYLINDERS, CRANKCASE AND CRANK ASSEMBLY			38	Crankcase Bottom Cover Washer (Not Shown)	4	(Hardware Item)
8a. Cylinder Head Assy. (Includes Valves)	2	70111-11000-4024	39	Front & Rear Cover Bolt Washer (Not Shown)	10	92521-190600
8b. Cylinder Head (Bare Casting)	2	70111-11010	40	Compressor Pulley Pin	1	70112-56060
9. Cylinder Head Gasket	2	70111-11612	41	Compressor Pulley	1	70121-76011
10. Cylinder Head Bolt	8	91501-1306055	42	Compressor Pulley Thrust Washer	1	70112-76210
11. Cylinder	2	70121-51010	43	Compressor Pulley Thrust Bolt	1	91501-1306025
12. Cylinder To Case Gasket	2	70121-51610	44	Oil Level Gauge & Gauge Cover	1	70111-57700
13. Cylinder To Case Bolt (Not Shown)	8	91501-1306016	*44A	Oil Level Gauge Assy	1	70704-57700
14. Cylinder To Case Bolt Washer (Not Shown)	16	92521-190600	45	Oil Level Gauge Cover Seal	1	70111-57730
15. Compression Ring	4	70111-61030	*45A	Oil Level Gauge "O" Ring	1	93602-8126026
16. Oil Control Ring	2	70111-61050	46	Crankcase Oil Plug (1/4" NPT)	1	90112-100202
17. Piston	2	70111-61011	47	Breather Assembly	1	CCC1357
18. Piston Pin	2	70111-61120	UNLOADERS(* Indicates Not Included On Basic Units)			
19. Piston Pin Snap Ring	4	70111-61070	48	Auto - Unloader Assembly	2	70112-11201
20. Connecting Rod Assembly	2	70111-61200	49	Unloading Elbow* (Includes Nut & Sleeve)	1	VA786
21. Connecting Rod Bolt	4	(Furnished On Conn. Rod Only)	50	Unloading Tee* (Includes Nut & Sleeve)	1	VA787
22. Oil Splash Dipper	2	70121-61282	AIR STRAINER ASSEMBLY & DISCHARGE PIPING			
23. Oil Splash Dipper Bolt	2	91507-2304010	51	Air Strainer Assembly	2	70111-66001
24. Oil Splash Dipper Lock washer	2	92522-130400	52	Air Strainer Element (Not Shown)	2	70111-66140
25. Crankshaft	1	70121-56010	53	Compressor Body Discharge Pipe Assembly	1	70121-87100
26. Crankcase	1	70121-57010-4024	54	Outlet Pipe Elbow	1	70121-87010
27. Front Bearing Cover	1	70121-57030	55	Outlet Pipe Tee	1	70121-87020
			56	Outlet Pipe Tee Nut	1	79922-130404

* START S/N AS 4030001

AIR COOLED, SINGLE STAGE MODELS
ES-05, ES-10 & ES-20

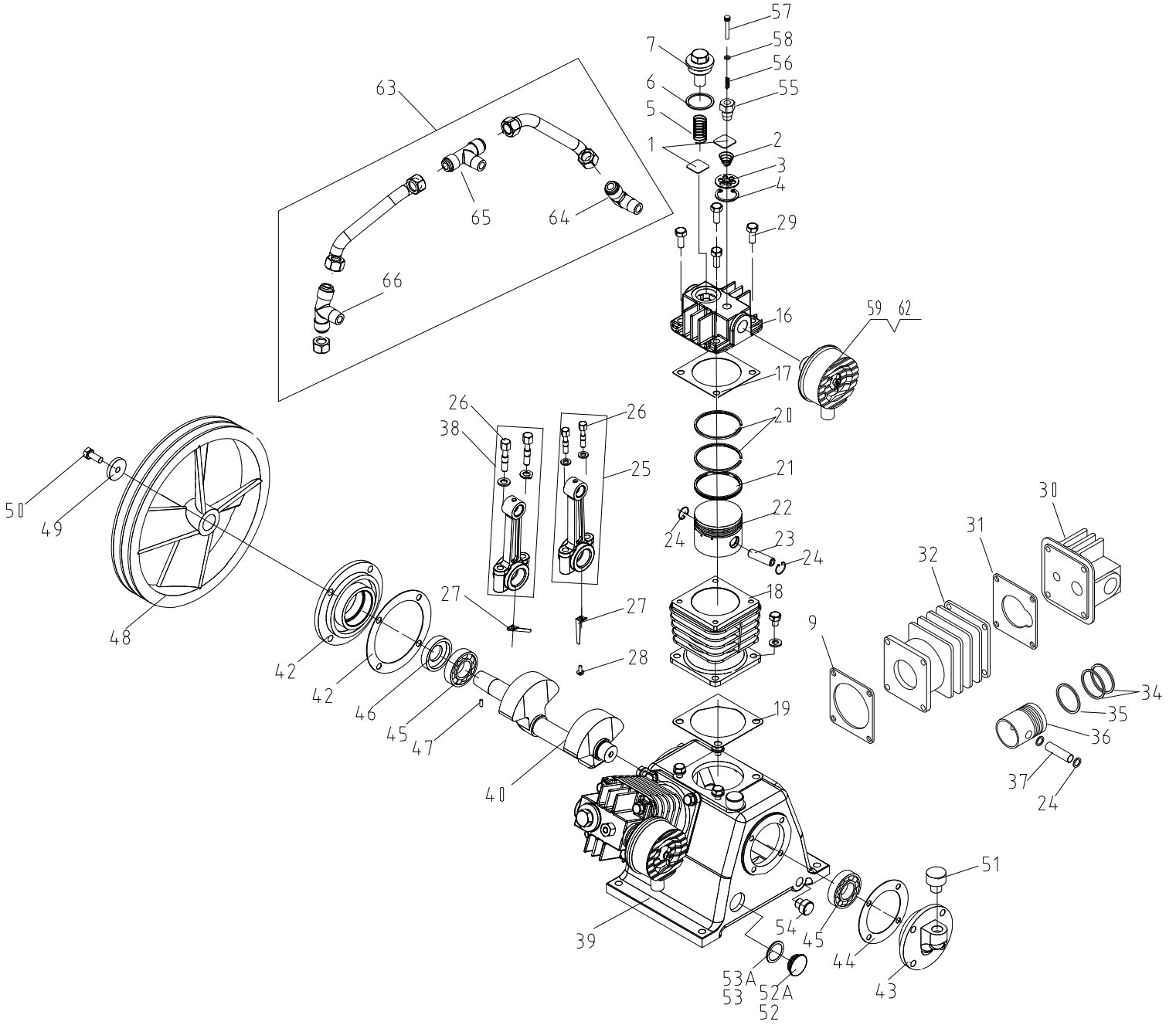

MAIN PARTS LISTING FOR SINGLE STAGE MODELS ES-05, ES-10 & ES-20

VALVES		QTY REQ'D	MODEL ES05	QTY REQ'D	MODEL ES10	QTY REQ'D	MODEL ES20
1.	Inlet And Outlet Valve Plate	2	70112-31030	4	70112-31030	6	70112-31030
2.	Inlet Valve Spring	1	70112-31070	2	70112-31070	3	70112-31070
3.	Inlet Valve Receiver	1	70112-31020	2	70112-31020	3	70112-31020
4.	Inlet Valve Snap Ring	1	93610-130232	2	93610-130232	3	93610-130232
5.	Outlet Valve Spring	1	70112-41070	2	70112-41070	3	70112-41070
6.	Outlet Valve Push Cover Gasket	1	70112-11461	2	70112-11461	3	70112-11461
7.	Outlet Valve Push Cover	1	70112-11450	2	70112-11450	3	70112-11450
CYLINDER AND CYLINDER HEADS							
16A.	Cylinder Head Assembly	1	70112-11000-4024	2	70112-11000-4024	3	70112-11000-4024
16B.	Cylinder Head	1	70112-11010	2	70112-11010	3	70112-11010
17.	Cylinder & Head Gasket	1	70112-11612	2	70112-11612	3	70112-11612
18.	Cylinder	1	70112-51010	2	70112-51010	3	70112-51010
19.	Cylinder And Case Gasket	1	70112-51610	2	70112-51610	3	70112-51610
20.	Compression Ring	2	70112-61030	4	70112-61030	6	70112-61030
21.	Oil Control Ring	1	70112-61050	2	70112-61050	3	70112-61050
22.	Piston	1	70112-61011	2	70112-61011	3	70112-61011
23.	Piston Pin	1	70112-61120	2	70112-61120	3	70112-61120
24.	Piston Pin Snap Ring	2	70112-61070	4	70112-61070	6	70112-61070
25.	Connecting Rod Assembly	1	70112-61200-1	2	70112-61200-1	3	70112-61200-1
26.	Connecting Rod Bolt	1	70112-61250	4	70112-61250	6	70112-61250
27.	Oil Splash Dipper	1	70111-61282	2	70122-61282	2	70122-61282
27A.	Oil Splash Dipper					1	70132-61290
28.	Oil Splash Dipper Bolts	1	91507-2304010	2	91507-2304010	3	91507-2304010
29.	Cylinder Head Bolt	4	(Hardware Item)	8	(Hardware Item)	12	(Hardware Item)
CRANK ASSEMBLY							
39.	Crankcase	1	70112-57010-4024	1	70122-57010-4024	1	70132-57010-4024
40.	Crankshaft	1	70112-56010	1	70122-56010	1	70132-56010
41.	Front Bearing Cover	1	70112-57030	1	70122-57030	1	70122-57030
42.	Front Bearing Cover Gasket	1	70112-57950	1	70122-57950	1	70122-57950
43.	Rear Bearing Cover	1	70112-57060	1	70122-57060	1	70122-57060
44.	Rear Bearing Cover Gasket	1	70112-57960	1	70122-57960	1	70122-57960
45A.	Bearing – Front	1	93501-6205	1	93501-6205	1	93501-6205
45B.	Bearing – Rear	1	93501-6204	1	93501-6204	1	93501-6204
46.	Front Oil Seal	1	70112-57080	1	70122-57080	1	70122-57080
47.	V-Pulley Pin	1	70112-56060	1	70112-56060	1	70112-56060
48.	Compressor Pulley	1	70112-76010	1	70122-76011	1	70122-76011
49.	Compressor Pulley Thrust Washer	1	70112-76210	1	70112-76210	1	70112-76210
50.	Compressor Pulley Thrust Bolt	1	91501-1308025	1	91501-1308025	1	91501-1308025
51.	Breather Assembly	1	CCC1375	1	CCC1375	1	CCC1375
52.	Oil Gauge & Gauge Cover	1	70111-57700	1	70111-57700	1	70111-57700
52 *A	Oil Level Gauge Assembly		-	1	70704-57700	1	70704-57700
53.	Gauge Cover Seal	1	70111-57730	1	70111-57730	1	70111-57730
53 *A	Oil Level Gauge "O" Ring		-	1	93602-8126026	1	93602-8126026
54.	Crankcase Oil Plug	1	90112-100202	1	90112-100202	1	90112-100202
54A.	Oil fill cap		-		-	1	70101-57190-4010
54B.	"O" Ring		-		-	1	93601-810016
UNLOADERS							
55.	Auto – Unloader Assembly	1	70112-11201	2	70112-11201	3	70112-11201
56.	Auto – Unloader Spring	1	70112-11230	2	70112-11230	3	70112-11230
57.	Auto – Unloader Piston	1	70112-11221	2	70112-11221	3	70112-11221
58.	O-Ring (Unloader)	1	93601-810004	2	93601-810004	3	93601-810004
AIR STRAINER							
61.	Air Strainer Element (not shown)	1	70111-66140	2	70111-66140	3	70111-66140
62.	Air Strainer Assembly	1	70111-66001	2	70111-66001	3	70111-66001
63.	Discharge Piping Assembly	1	(Not Required)	2	70122-87100	2	70132-87100
64.	Outlet Pipe Joint A		-	1	70122-87010	1	70122-87010
65.	Outlet Pipe Joint B		-	1	70122-87020	1	70132-87020
66.	Outlet Pipe Joint C		-		-	1	70132-87030

- ES10, START S/N AS 4030043
- ES20, START S/N AS 4030061

AIR COOLED SINGLE STAGE MODELS ES-30, ES-50, ES-100

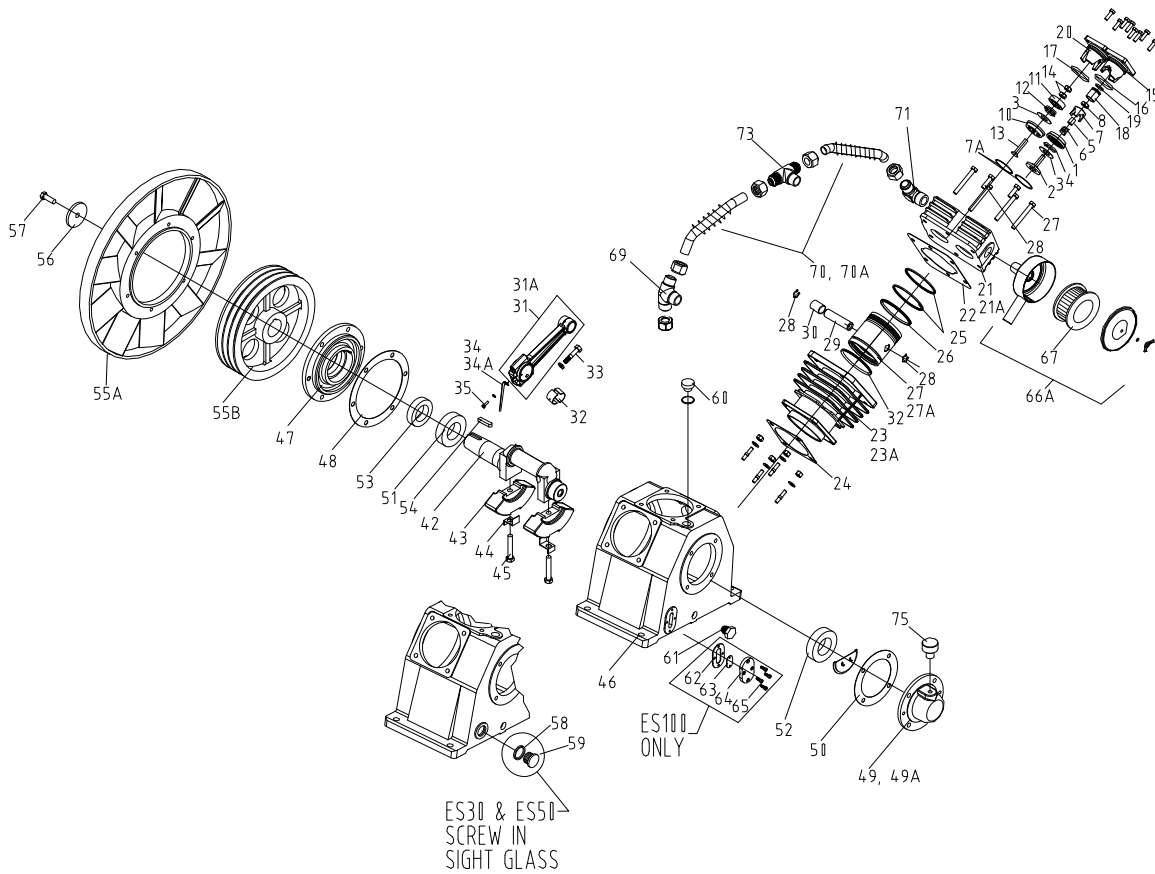

VALVE ASSEMBLIES	Description	Qty. Req.	MODEL ES30	Qty. Req.	MODEL ES50	Qty. Req.	MODEL ES100
	Inlet Valve Assembly, 1 st Stage	2	70123-31000	3	70123-31000	3	70124-31000
	Outlet Valve Assembly, 1 st Stage	2	70123-41000	3	70123-41000	3	70124-41000
	Breather Assembly	1	70103-57600-4024	1	70103-57600-4024	1	70124-57600

MAIN PARTS LISTING FOR MODELS ES-30, ES-50, ES-100

VALVE & UNLOADERS	Item No.	Description	Qty. Req.	MODEL ES30	Qty. Req.	MODEL ES50	Qty. Req.	MODEL ES100
	1.	Inlet Valve Seat	2	70123-31010	3	70123-31010	3	70124-31010
	2.	Inlet Valve Receiver	2	70123-31020	3	70123-31020	3	70124-31020
	3.	Inlet & Outlet Valve Plate	4	70123-31030	6	70123-31030	6	70124-31030
	4.	Inlet Valve Spring	2	70123-31070	3	70123-31070	3	70124-31070
	5.	Inlet Valve Unloading Fork Guide	2	70123-31090	3	70123-31090	3	70124-31090
	6.	Unloading Spring	2	70123-11230	3	70123-11230	3	70124-11230
	7A.	Valve Gasket	4	70123-11110	6	70123-11110	6	70124-11110

**MAIN PARTS LISTING FOR MODELS
ES-30, ES-50 & ES-100 (Continued)**

		Qty. Req.	MODEL ES30	Qty. Req.	MODEL ES50	Qty. Req.	MODEL ES100		
VALVES & UNLOADERS (Cont'd)	7B	Inlet Valve Unloading Fork	2	70123-31080	3	70123-31080	3	70124-31080	
	8.	Locknut	2	92518-230800	3	92518-230800	3	92518-230800	
	10.	Outlet Valve Seat	2	70123-41011	3	70123-41011	3	70124-41011	
	11.	Outlet Valve Receiver	2	70123-41020	3	70123-41020	3	70124-41020	
	12.	Outlet Valve Spring	2	70123-41070	3	70123-41070	3	70124-41070	
	13.	Outlet Valve Bolt	2	70123-41810	3	70123-41810	3	70124-41810	
	14.	Nut (Outlet Valve)	4	92502-130800	6	92502-130800	6	92502-130800	
	15.	Inlet Valve Push Cover, 1 st Stage	2	70123-11150	3	70123-11150	3	70124-11150	
	16.	O – Ring G 40	2	93602-810040	3	93602-810040	3	93602-810055	
	17.	Viton O – Ring G 40 (Outlet Valve)	2	93602-870040	3	93602-870040	3	93602-870055	
	18.	Unloading Piston, 1 st Stage	2	70123-11220	3	70123-11220	3	70124-11220	
	19.	O – Ring P 20	2	93601-810020	3	93601-810020	3	93601-810021	
	20.	Outlet Valve Push Cover, 1 st Stage	2	70123-11450	3	70123-11450	3	70124-11450	
	CYLINDERS	21A.	Cylinder Head Assembly	2	70123-11000	3	70123-11000	-	-
		21.	Cylinder Head (1 st)	2	70123-11010	3	70123-11010	3	70124-11010
		22.	Cylinder & Head Gasket, 1 st Stage	2	70123-11612	3	70123-11612	3	70124-11612
		23.	Cylinder (1 st)	2	70123-51012	3	70123-51012	3	70124-51011
		23A.	S/N 3020000 THRU A311XXXX	2	70123-51011	3	70123-51011	3	70124-51011
		24.	Cylinder & Case Gasket	2	70123-51610	3	70123-51610	3	70124-51610
		25.	Compression Ring (1 st)	4	70123-61030	6	70123-61030	6	70124-61030
26.		Oil Control Ring (1 st)	4	70123-61050	6	70123-61050	6	70124-61050	
27.		Piston (1 st)	2	70123-61011	3	70123-61011	3	70124-61011-1	
27A.		S/N 3020000 & later use	2	70123-61011	3	70123-61011	3	70124-61011	
28.		Piston Pin Snap Ring	4	70123-61070	6	70123-61070	6	70124-61070	
29.		Piston Pin (1 st)	2	70123-61120	3	70123-61120	3	70124-61120	
30.		Connecting Rod Piston Pin Bushing (1 st)	2	70123-61081	3	70123-61081	3	70124-61080	
31.		Connecting Rod Assembly, 1 st Stage	2	70123-61200	3	70123-61200	3	70124-61201	
31A.		S/N 3020000 & later use	2	70123-61201	3	70123-61201	3	70124-61201	
32.		Connecting Rod Crank Pin Metal	4	70123-61090	6	70123-61090	6	70124-61090	
33.		Connecting Rod Bolt	4	70123-61250	6	70123-61250	6	70125-61250	
34A.		Oil Splash Dipper H.P.	-	-	1	70122-61290	1	70134-62290	
34.		Oil Splash Dipper	2	70122-61282	2	70122-61282	2	70134-61281	
35.		Oil Splash Dipper Bolt	2	91507-2304012	3	91507-2304012	3	91507-2305016	
CRANKCASE & CRANK ASSEMBLY		42.	Crankshaft	1	70123-56010	1	70133-56011	1	70134-56010
		43.	Counterweight	-	-	-	-	2	70134-56030
		44.	Lockwasher	-	-	-	-	2	70124-56830
		45.	Bolt	-	-	-	-	2	70124-56810
		46.	Crankcase	1	70123-57010-4024	1	70133-57010-4024	1	70134-57010-4024
		47.	Front Bearing Cover	1	70123-57030	1	70133-57030	1	70134-57031
		48.	Front Bearing Cover Gasket	1	70123-57950	1	70123-57950	1	70124-57950
		49.	Rear Bearing Cover	1	70123-57061	1	70133-57060	1	70134-57061
		49A.	S/N 3020000 & later use	1	70123-57061	1	70133-57061	1	70134-57061
		50.	Rear Bearing Cover Gasket	1	70123-57960-01	1	70133-57960	1	70134-57960
		51.	Front Bearing	1	93501-6206	1	93501-6206	1	93502-32210
		52.	Rear Bearing	1	93501-6206	1	93501-6206	1	93502-32210
		53.	Front Oil Seal	1	70123-57080	1	70123-57080	1	70134-57080
		54.	V – Pulley Pin	1	70123-56061	1	70123-56061	1	70134-56060
		55A.	Compressor Fan	1	(Not Required)	1	(Not Required)	1	70124-76310
	55B.	Compressor Pulley	1	70123-76010	1	70133-76010	1	70134-76011	
	56.	Compressor Pulley Washer	1	70123-76210	1	70124-76210	1	70124-76210	
	57.	Compressor Pulley Set Bolt	1	91501-1312030	1	91501-1312030	1	91501-1312040	
	58.	O-Ring (oil level glass)	1	93602-81260-3065	1	93602-81260-3065	-	-	
	59.	Screw in Oil Level Glass	1	70A109B1-57702	1	70A109B1-57702	-	-	
	60.	Crankcase Oil Cap	1	CCC1257	1	CCC1257	1	CCC1257	
	61.	Crankcase Oil Plug	1	90112-100404	1	90112-100404	1	90112-100404	
	62.	Oil Level Glass Gasket	1	701210A1-57730	1	701210A1-57730	1	701210A1-57730	
	63.	Oil Level Glass Assy.	1	701210A1-57700	1	701210A1-57700	1	701210A1-57700	
	64.	Oil Level Glass, Push Cover	1	701210A1-57740	1	701210A1-57740	1	701210A1-57740	
	65.	Screw, Metric Pan Head	4	VH1470	4	VH1470	4	VH1470	
	66A	Air Strainer Assembly	2	70123-66000	3	70123-66000	3	70123-66000	
	67.	Air Strainer Filter	2	70123-66140	3	70123-66140	3	70123-66140	
	69.	Outlet Pipe Joint B	1	70123-87020	1	70133-87020	1	70134-87020	
	70.	Compressor Body Discharge Piping Assy.	1	70123-87100	2	70133-87101	2	70134-87100	
	70A.	S/N 3020000 & Later Use	1	70123-87101	2	70133-87101	2	70134-87101	
	71.	Outlet Pipe Joint A	1	70123-87010	1	70123-87010	1	70124-87010	
	73.	Outlet Pipe Joint C	-	-	1	70133-87030	1	70134-87030	
	74.	Gasket (Manifold)	-	-	-	-	-	-	
	75.	Breather Assembly	1	CCC1375	1	CCC1375	1	CCC1375	

AIR COOLED SINGLE STAGE MODELS ES-30A, ES-50A, ES-100A

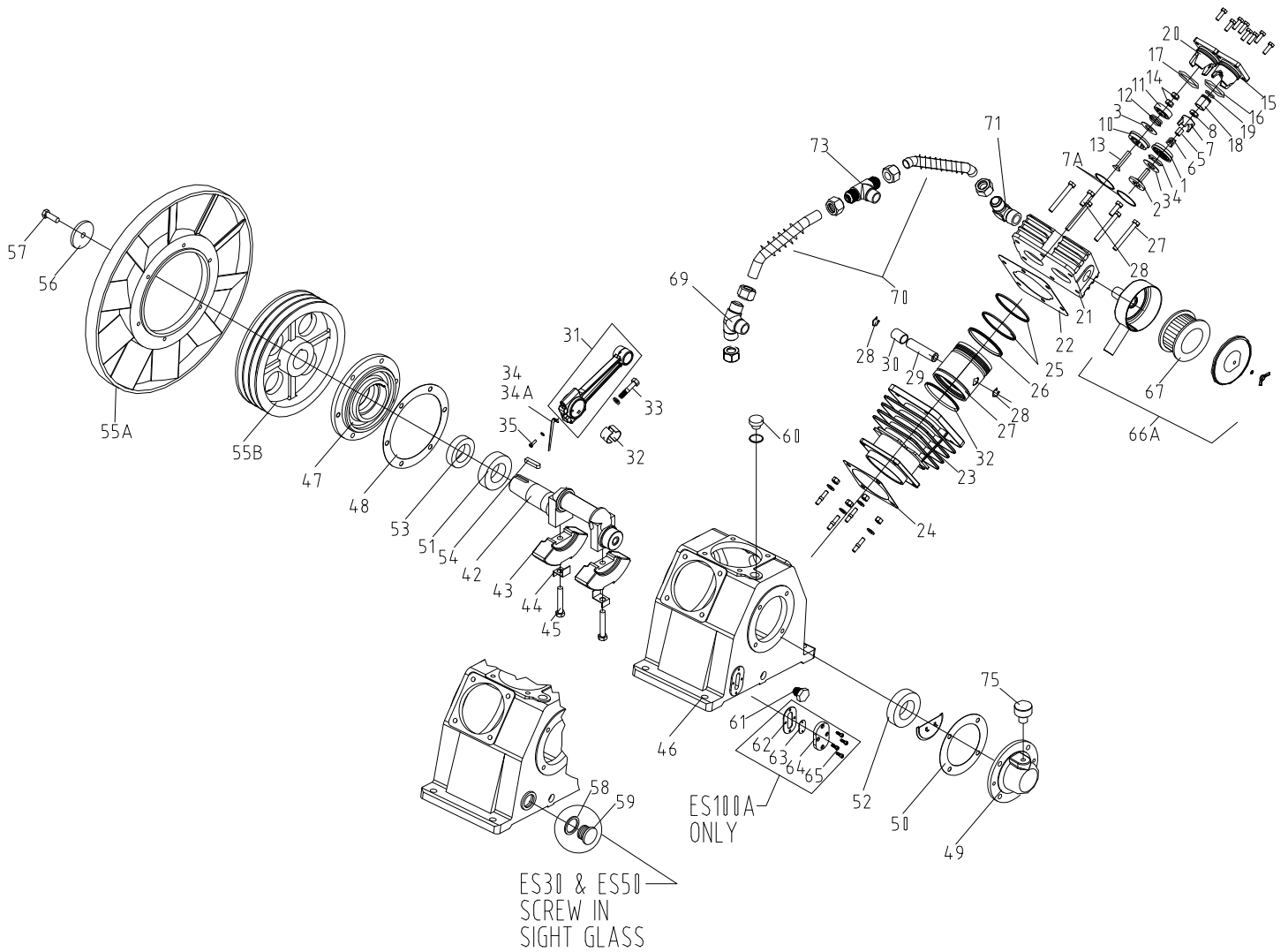

VALVE ASSEMBLIES	Description	Qty. Req.	MODEL ES30A	Qty. Req.	MODEL ES50A	Qty. Req.	MODEL ES100A
	Inlet Valve Assembly, 1 st Stage	2	701208A1-31000	3	701208A1-31000	3	701210A1-31000
Outlet Valve Assembly, 1 st Stage	2	701208A1-41000	3	701208A1-41000	3	701210A1-41000	
Breather Assembly	1	701105A1-57600	1	701105A1-57600	1	701210A1-57601	

MAIN PARTS LISTING FOR MODELS ES-30A, ES-50A, ES-100A

VALVE & UNLOADERS	Item No.	Description	Qty. Req.	MODEL ES30A	Qty. Req.	MODEL ES50A	Qty. Req.	MODEL ES100A
	1.	Inlet Valve Seat	2	701208A1-31010	3	701208A1-31010	3	701210A1-31010
2.	Inlet Valve Receiver	2	701208A1-31020	3	701208A1-31020	3	701210A1-31020	
3.	Inlet & Outlet Valve Plate	2	701208A1-31030	6	701208A1-31030	6	501210A1-31030	
4.	Inlet Valve Spring	2	701208A1-31070	3	701208A1-31070	3	701210A1-31070	
5.	Inlet Valve Unloading Fork Guide	2	701208A1-31090	3	701208A1-31090	3	701210A1-31090	
6.	Unloading Spring	2	701208A1-11230	3	701208A1-11230	3	701210A1-11230	
7A.	Valve Gasket	4	701208A1-11110	6	701208A1-11110	6	701210A1-11110	

**MAIN PARTS LISTING FOR MODELS
ES-30A, ES-50A & ES-100A (Continued)**

		Qty. Req.	MODEL ES30A	Qty. Req.	MODEL ES50A	Qty. Req.	MODEL ES100A			
VALVES & UNLOADERS (Cont'd)	7B.		Inlet Valve Unloading Fork	2	701208A1-31080	3	701208A1-31080	3	70210A1-31080	
	8.		Locknut	2	9251313-150800-532	3	9251313-150800-532	3	9251313-151000-532	
	10.		Outlet Valve Seat	2	701208A1-41011	3	701208A1-41011	3	701210A1-41011	
	11.		Outlet Valve Receiver	2	701208A1-41020	3	701208A1-41020	3	701210A1-41020	
	12.		Outlet Valve Spring	2	701208A1-41070	3	701208A1-41070	3	701210A1-41070	
	13.		Outlet Valve Bolt	2	701208A1-41810	3	701208A1-41810	3	9152613-1110050-5608	
	14.		Nut (Outlet Valve)	4	9250113-150800-532	6	9250113-150800-532	6	9250113-121000-532	
	15.		Inlet Valve Push Cover, 1 st Stage	2	701208A1-11150	3	701208A1-11150	3	701210A1-11150	
	16.		O – Ring G 40 (G55 ES100)	2	9360281-310394	3	9360281-310394	3	9360281-310544	
	17.		Viton O – Ring G 40 (Outlet Valve)	2	9360287-310394	3	9360287-310394	3	9360287-310544	
	18.		Unloading Piston, 1 st Stage	2	701208A1-11220	3	701208A1-11220	3	701210A1-11220	
	19.		O – Ring P 20 (P21 ES100)	2	9360181-240198	3	9360181-240198	3	9360187-240208	
	20.		Outlet Valve Push Cover, 1 st Stage	2	701208A1-11450	3	701208A1-11450	3	701210A1-11450	
	CYLINDERS	21A.		Cylinder Head Assembly	2	70123-11000	3	70123-11000		-
		21.		Cylinder Head (1 st)	2	701208A2-11010	3	701208A2-11010	3	701210A2-11010
		22.		Cylinder & Head Gasket, 1 st Stage	2	701208A1-11020	3	701208A1-11020	3	701210A1-11020
		23.		Cylinder (1 st)	2	701208A2-51010	3	701208A2-51010	3	701210A2-51010
		23A.		S/N 3020000 THRU A311XXXX	2	701208A1-51010	3	701208A2-51010	3	701210A2-51010
		24.		Cylinder & Case Gasket	2	701208A1-51030	3	701208A1-51030	3	701210A1-51030
25.			Compression Ring (1 st)	4	701208A1-61030	6	701208A1-61030	6	701210A1-61030	
26.			Oil Control Ring (1 st)	4	701208A1-61050	6	701208A1-61050	6	701210A1-61050	
27.			Piston (1 st)	2	701208A1-61012	3	701208A1-61012	3	701210A1-61011	
27A.			S/N 3020000 & later use	2	70123-61011	3	70123-61011	3	701210A1-61011	
28.			Piston Pin Snap Ring	4	701208A1-61070	6	701208A1-61070	6	701210A1-61070	
29.			Piston Pin (1 st)	2	701208A1-61120	3	701208A1-61120	6	701210A1-61120	
30.			Connecting Rod Piston Pin Bushing (1 st)	2	70123-61081	3	70123-61081	3	70124-61080	
31.			Connecting Rod Assembly, 1 st Stage	2	701208A1-61201	3	701208A1-61201	3	701210A1-61201	
31A.			S/N 3020000 & later use	2	701208A1-61201	3	701208A1-61201	3	701210A1-61201	
32.			Connecting Rod Crank Pin Metal	4	70123-61090	6	70123-61090	6	70124-61090	
33.			Connecting Rod Bolt	4	70123-61250	6	70123-61250	6	70125-61250	
33A.			Oil Splash Dipper H.P.		-	1	70130FA1-61290	1	701310A1-61290	
34.			Oil Splash Dipper	2	70120FA1-61282	2	70120FA1-61282	2	701310A1-61281	
35.			Oil Splash Dipper Bolt	2	9151313-1104012-5602	3	9151313-1104012-5602	3	9151313-1105016-5602	
CRANKCASE & CRANK ASSEMBLY		42.		Crankshaft	1	701208A1-56011	1	701308A1-56011	1	701310A1-56010
		43.		Counterweight		-		-	2	701310A1-56030
		44.		Lockwasher		-		-	2	701210A1-56830
		45.		Bolt		-		-	2	701210A1-56810
		46.		Crankcase	1	701208A2-57010	1	701308A2-57010	1	701310A2-57010
		47.		Front Bearing Cover	1	701208A1-57030	1	701308A1-57030	1	701310A1-57031
		48.		Front Bearing Cover Gasket	1	701208A1-57040	1	701208A1-57040	1	701210A1-57040
		49.		Rear Bearing Cover	1	701208A1-57061	1	701308A1-57061	1	701310A1-57061
		49A.		S/N 3020000 & later use	4	701208A1-57061	4	701308A1-57061	4	701310A1-57061
		50.		Rear Bearing Cover Gasket	1	701208A1-57070	1	701308A1-57070	1	701310A1-57070
		51.		Front Bearing	1	9350104-6206	1	9360112-6306	1	9354501-32210
		52.		Rear Bearing	1	9350104-6206	1	9360112-6306	1	9354501-32210
		53.		Front Oil Seal	1	701208A1-57080	1	701208A1-57080	1	701310A1-57080
		54.		V – Pulley Pin	1	701208A1-56061	1	701208A1-56061	1	701310A1-56060
		55A.		Compressor Fan	1	(Not Required)	1	(Not Required)	1	70121071-76311
	55B.		Compressor Pulley	1	701208A1-76010	1	701308A1-76010	1	701310A1-76011	
	56.		Compressor Pulley Washer	1	701208A1-76210	1	70124-76210	1	701210A1-76210	
	57.		Compressor Pulley Set Bolt	1	9150113-1112030-5608	1	9150113-1112030-5608	1	9150113-1112040-5608	
	58.		O-ring (Oil Level Glass)	1	93602-81260-3065	1	93602-81260-3065	-	-	
	59.		Screw In Oil Level Glass	1	70A109B1-577002	1	70A109B1-577002	-	-	
	60.		Crankcase Oil Cap	1	CCC1257	1	CCC1257	1	CCC1257	
	61.		Crankcase Oil Plug	1	9156310-400800	1	9156310-400800	1	9156310-400800	
	62.		Oil Level Glass Gasket	1	701210A1-57730	1	701210A1-57730	1	701210A1-57730	
	63.		Oil Level Glass Assembly	1	701210A1-57700	1	701210A1-57700	1	701210A1-57700	
	64.		Oil Level Glass, Push Cover	1	701210A1-57740	1	701210A1-57740	1	701210A1-57740	
	65.		Screw, Metric Pan Head	4	VH1470	4	VH1470	4	VH1470	
	66A.		Air Strainer Assembly	2	701208A1-66000	3	701208A1-66000	3	701312A1-66000	
	67.		Air Strainer Filter	2	701208A1-66140	3	701208A-66110	3	701208A1-66110	
	69.		Outlet Pipe Joint B	1	70123-87020	1	70133-87020	1	70134-87020	
	70.		Compressor Body Discharge Piping Assy.	1	70123-87100	2	701308A1-87101	2	70134-87100	
	70A.		S/N 3020000 & Later Use	4	701208A1-87101	2	701308A1-87101	2	701310A1-87101	
	71.		Outlet Pipe Joint A	1	701208A1-87011	1	70123-87010	1	70124-87010	
73.		Outlet Pipe Joint C		-	1	70133-87030	1	70134-87030		
74.		Gasket (Manifold)		-		-		-		
75.		Breather Assembly	1	CCC1375	1	CCC1375	1	CCC1375		

AIR COOLED, SINGLE STAGE MODEL ES-150

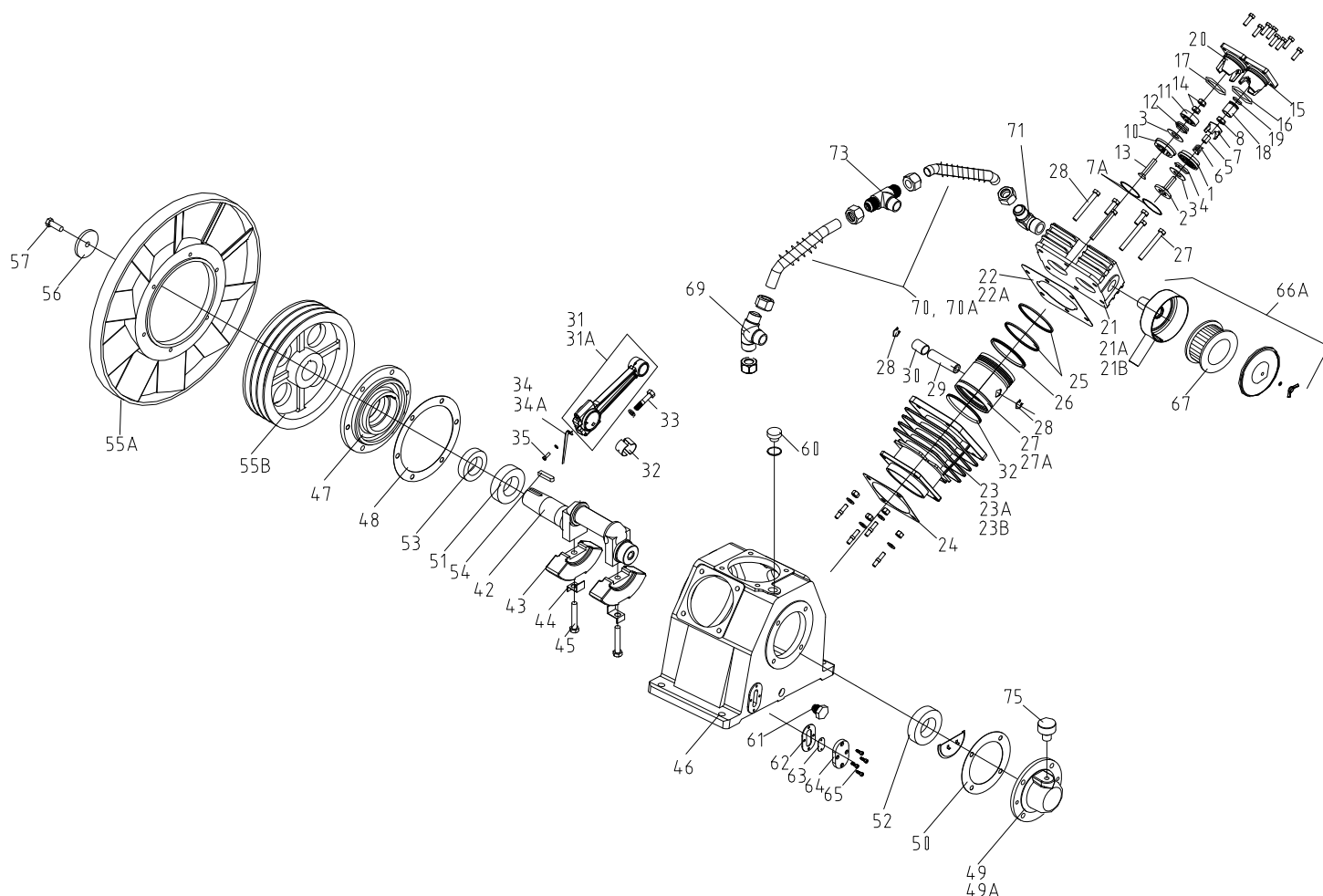

VALVE ASSEMBLIES	DESCRIPTION	Qty. Req.	MODEL ES150
	Inlet Valve Assembly, 1 st Stage	3	70125-31000
	Outlet Valve Assembly, 1 st Stage	3	70125-41000
	Breather Assembly	1	70124-57600

MAIN PARTS LISTING FOR MODEL ES-150

VALVE & UNLOADERS	DESCRIPTION	Qty. Req.	MODEL ES150
	1. Inlet Valve Seat	3	70125-31010
	2. Inlet Valve Receiver	3	70125-31021
	3. Inlet & Outlet Valve Plate	6	70125-31030
	4. Inlet Valve Spring	3	70125-31070
	5. Inlet Valve Unloading Fork Guide	3	70125-31090
	6. Unloading Spring	3	70125-11230
7A. Valve Gasket	6	70125-11110	

**MAIN PARTS LISTING FOR MODEL
ES-150 (Continued)**

CAP-600

	DESCRIPTION	Qty. Req.	MODEL ES150
VALVES & UNLOADERS (Cont'd)	7B. Inlet Valve Unloading Fork	3	70125-31080
	8. Locknut	3	92517-231200
	10. Outlet Valve Seat	3	70125-41011
	11. Outlet Valve Receiver	3	70125-41025
	12. Outlet Valve Spring	3	70125-41074
	13. Outlet Valve Bolt	3	70124-41810
	14. Nut (Outlet Valve)	6	92502-131000
	15. Inlet Valve Push Cover, 1 st Stage	3	70125-11151
	16. O – Ring G 65	3	93602-810065
	17. Viton O – Ring G 65 (Outlet Valve)	3	93602-870065
	18. Unloading Piston, 1 st Stage	3	70125-11220
	19. O – Ring P 22A	3	93601-870022A
	20. Outlet Valve Push Cover, 1 st Stage	3	70125-11451
	21A. Cylinder Head Assembly		70135-11000A
	21. Cylinder Head (1 st)	3	70125-11010
	21B. S/N A311XXXX AND LATER	3	70135-11011
	22. Cylinder & Head Gasket, 1 st Stage	3	70125-11612
	22A. S/N A311XXXX AND LATER	3	70135-11612
	23. Cylinder (1 st)	3	70135-51011
	23A. S/N 3020000 THRU A311XXXX	3	70135-51010
23B. S/N A311XXXX AND LATER	3	70135-51011	
24. Cylinder & Case Gasket	3	70135-51610	
25. Compression Ring (1 st)	6	70125-61030	
26. Oil Control Ring (1 st)	6	70125-61050	
27. Piston (1 st)	3	70125-61010	
27A. S/N 3020000 & later use	3	70135-61010-1	
28. Piston Pin Snap Ring	6	70125-61070	
29. Piston Pin (1 st)	3	70125-61120	
30. Connecting Rod Piston Pin Bushing (1 st)	3	70125-61081	
31. Connecting Rod Assembly, 1 st Stage	3	70125-61200	
31A. S/N 3020000 & later use	3	70125-61200	
32. Connecting Rod Crank Pin Metal	6	70125-61090	
33. Connecting Rod Bolt	6	70125-61250	
34A. Oil Splash Dipper H.P.		-	
34. Oil Splash Dipper	3	70135-61281	
35. Oil Splash Dipper Bolt	3	92501-130800	
CYLINDERS	42. Crankshaft	1	70135-56011
	43. Counterweight	2	70135-56031
	44. Lockwasher	2	70135-56830
	45. Bolt	2	70135-56811
	46. Crankcase	1	70135-57010-4024
	47. Front Bearing Cover	1	70135-57030
	48. Front Bearing Cover Gasket	1	70135-57950
	49. Rear Bearing Cover	1	70134-57061
	49A. S/N 3020000 & later use	1	70134-57061
	50. Rear Bearing Cover Gasket	1	70134-57960
	51. Front Bearing	1	93502-30310
	52. Rear Bearing	1	93502-32210
	53. Front Oil Seal	1	70134-57080
	54. V – Pulley Pin	1	70134-56060
	55A. Compressor Fan	1	70135-76310
	55B. Compressor Pulley	1	70135-76011
	56. Compressor Pulley Washer	1	70124-76210
	57. Compressor Pulley Set Bolt	1	91501-1312050
	60. Crankcase Oil Cap	1	CCC1257
	61. Crankcase Oil Plug	1	90112-100404
	62. Oil Level Glass Gasket	1	701210A1-57730
	63. Oil Level Glass Assembly	1	701210A1-57700
	64. Oil Level Glass, Push Cover	1	701210A1-57740
	65. Screw, Metric Pan Head	4	VH1470
	66A. Air Strainer Assembly	3	70123-66001
	67. Air Strainer Filter	3	70123-66140
	69. Outlet Pipe Joint B	1	70135-87021
	70. Compressor Body Discharge Piping Assy.	2	70135-87100 (Long)
	70A. S/N 3020000 & Later Use	2	70135-87200 (Short)
	71. Outlet Pipe Joint A	1	70135-87011
	73. Outlet Pipe Joint C	1	70135-87031
	74. Gasket (Manifold)	3	70125-87510
	Discharge Piping Assembly	1	70135-87700
	Discharge Piping Assembly	1	70135-87800
	Discharge Piping Assembly	1	70135-87900
	75. Breather Assembly	1	CCC1258

AIR COOLED SINGLE STAGE MODEL ES-150A

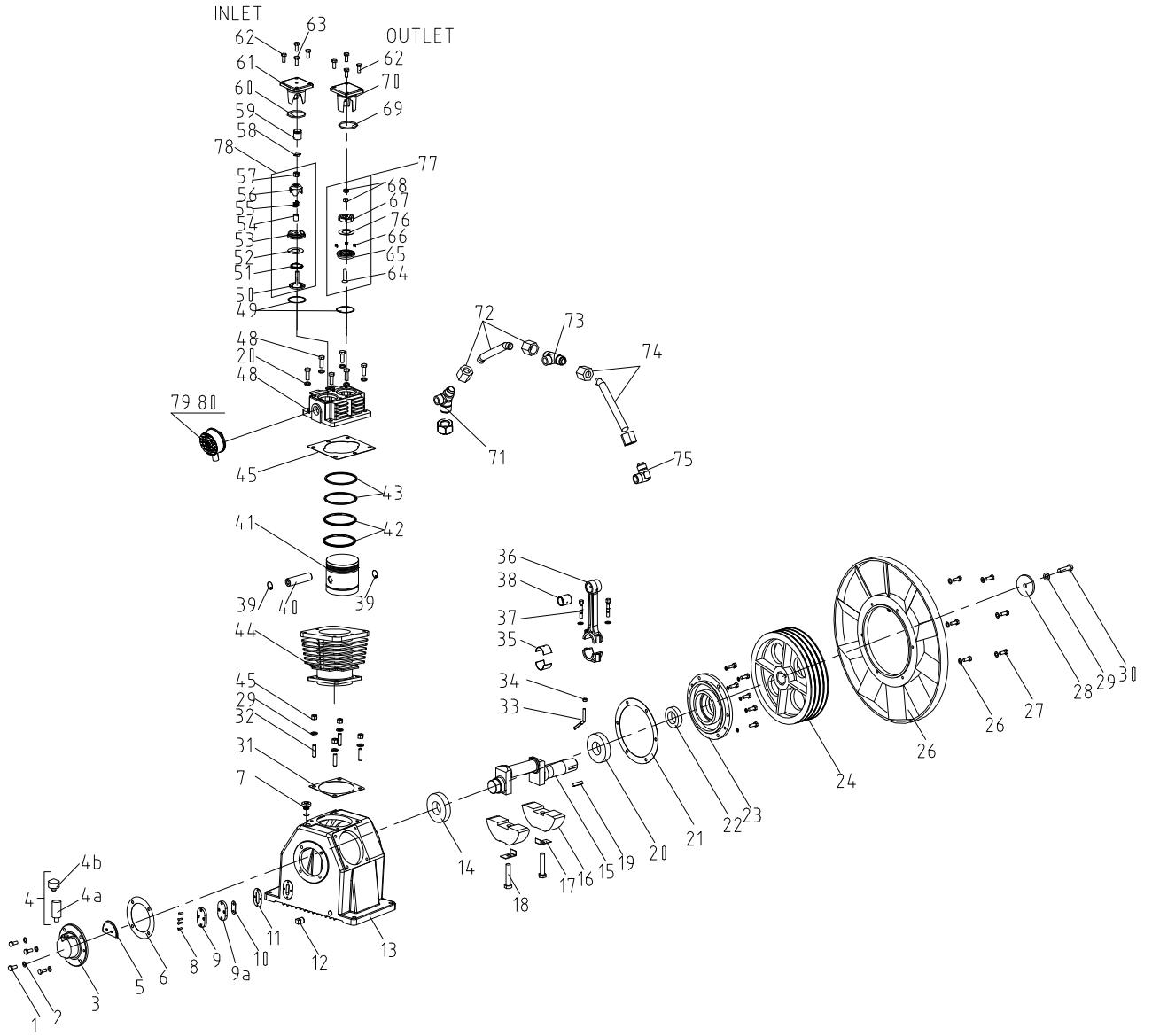

**AIR COOLED SINGLE STAGE
MODEL ES-150B**

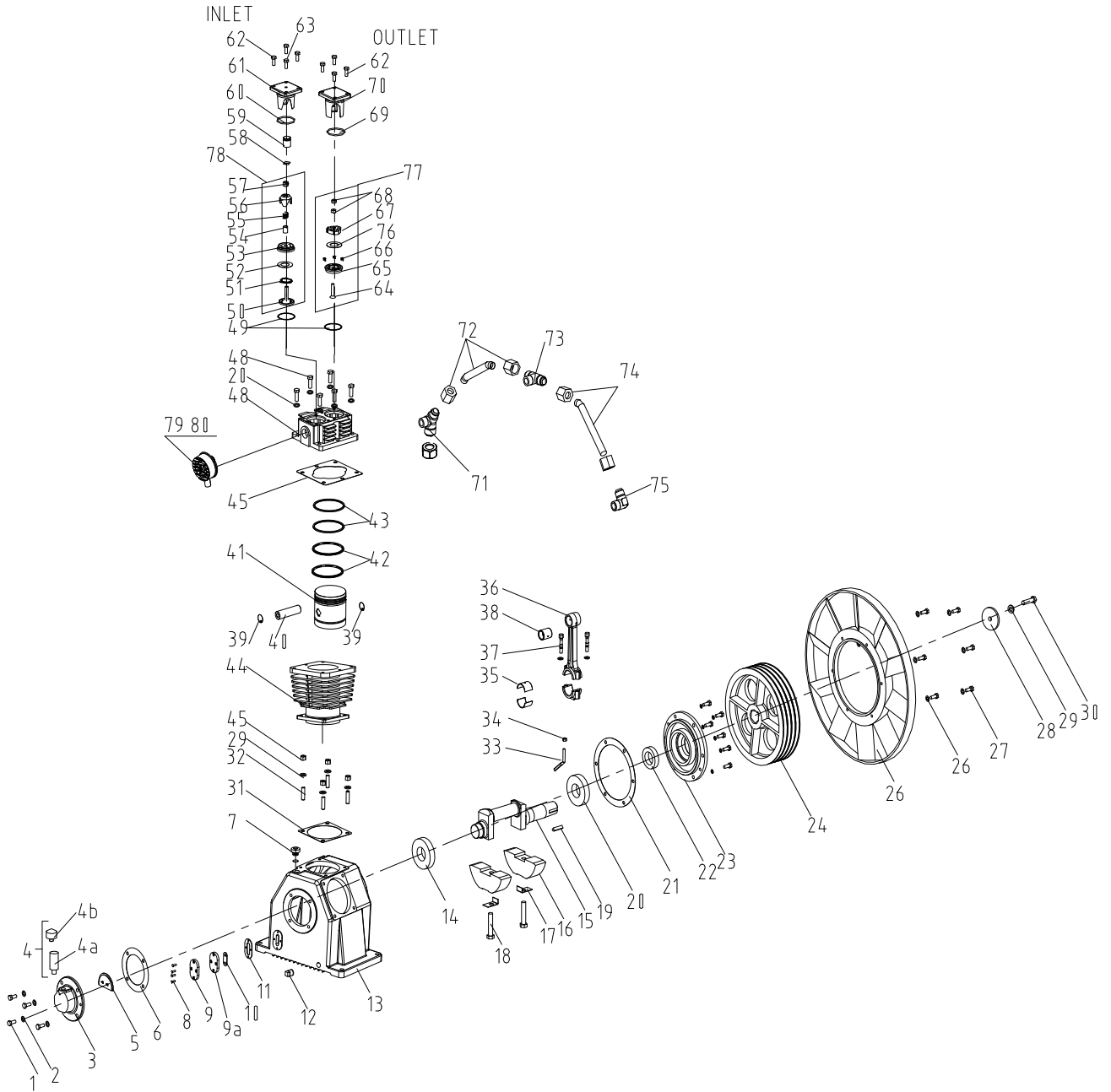

**MAIN PARTS LISTING FOR
MODEL ES150B**

ITEM NO.	PART NO.	DESCRIPTION	QTY
1	91501-1310025	BOLT, M10 X 25	10
2	9252615-101000-0	COPPER WASHER	10
3	701310A1-57061	REAR BEARING COVER	1
4	70131B81-57670	TUBE & BRTHR. ASSY.	1
4a	70131BA1-57670	TUBE, BREATHER	1
4b	CCC1697	BREATHER, ASSY.	1
5	701310A1-57590	REAR COVER OIL BAFFLE	1
6	701310A1-57070	REAR BRG CVR GASKET	1
7	70123-57190-4010	CRANKCASE OIL CAP	1
8	VH1470	GAUGE SET BOLT	4
9	701210A1-57740	OIL GLASS & COVER	1
9a	701210A1-57700	OIL COVER ASSY	1
10	70124-57750	OIL COVER GLASS	1
11	701210A1-57730	GAUGE COVER SEAL	1
12	9156310-400800	CRANKCASE OIL PLUG	1
13	701312A3-57010	CRANKCASE	1
14	9354504-30310	BEARING #30310	1
15	701312A1-56011	CRANKSHAFT	1
16	701312A1-56032	CRANKSHAFT CTR. WGT.	2
17	701312A1-56830	CTR WGT LK WASHER	2
18	701312A1-56811	CTR WGT MGT BOLT	2
19	701310A1-56060	V-PULLEY KEY	1
20	9354501-32210	BEARING #32210	1
21	70135-57950	FRONT BEARING GASKET	1
22	701310A1-57080	FRONT OIL SEAL	1
23	701312A1-57030	FRONT BEARING COVER	1
24	701312A1-76011	COMPRESSOR PULLEY	1
25	70131283-76310	COMP PULLEY FAN	1
26	9253113-100800-8	WASHER	6
27	9150113-1108030-5202	BOLT	6
28	701210A1-76210	PULLEY THRUST WASHER	1
29	9253113-101200-8	SPRING WASHER	1
30	9150113-1112050-5608	BOLT	1
31	701312A1-51030	CYL & CASE PACKING	3
32	701312A1-51810	CYL & CASE BOLT	12
33	701312A1-61281	OIL SPLASH DIPPER	3
34	9250113-120800-538	NUT	3
35	701212A1-61090	CONN.ROD CRANK PIN METL	6
36	701212A1-61200	CONN.ROD ASS'Y	3
37	70125-61250	CONN.ROD ASS'Y BOLT	6
38	501312A1-61081	CONN.ROD CRANK PIN METL	3
39	701212A1-61070	PISTON PIN SNAP RING	6
40	701212A1-61120	PISTON PIN	3
41	701312A1-61010	PISTON	3
42	701212A1-61050	OIL CONTROL RING	6
43	701212A1-61030	COMPRESSION RING	6
44	701312A3-51010	CYLINDER	3
45	92501-131200	NUT	12
46	701312A3-11020	CYL & HEAD GASKET	3
47	9250113-121200-538	BOLT	12
48	701312A3-11010	CYLINDER HEAD	3
49	701212A1-11110	I/O VALVE SEAT GASKET	6

ITEM NO.	PART NO.	DESCRIPTION	QTY
50	701212A1-31023	INLET VALVE RECEIVER	3
51	701212A1-31070	INLET VALVE SPRING	3
52	501212A1-31030	PLATE, INLET VALVE	3
53	701212A1-31010	INTER VALVE SEAT	3
54	701212A1-31090	I. VALVE UNLOAD FORK GUIDE	3
55	701212A1-11230	UNLOADING SPRING	3
56	701212A1-31080	I.VALVE UNLOAD FORK	3
57	9250413-151200-532	SLOTTED NUT	3
58	9360187-350217	O-RING P#22A	3
59	701212A1-11220	UNLOADING PISTON	3
60	9360287-310644	O-RING G#65	3
61	701212A1-11151	I. VALVE PUSH COVER	3
62	91501-1310025	BOLT	3
63	90112-100101	SCREW PLUG	24
64	70124-41810	BOLT	3
65	701212A1-41012	OUTLET VALVE SEAT	3
66	701212A1-41075	OUTLET VALVE SPRING	3
67	701212A1-41025	OUTLET VALVE RECEIVR	9
68	92501-231000	NUT	3
69	9360287-310644	VITON O-RING G#65	6
70	701212A1-11451	O. VALVE PUSH COVER	3
71	701312A1-87032	DIST. MANIFOLD #C	3
72	70135-87101	COMP.BODY DIS. PIPING ASSEMBLY	1
73	701312A1-87022	DIST. MANIFOLD #B	1
74	701312A2-87100	COMP.BODY DIS. PIPING ASSEMBLY	1
75	701312A2-87011	DIST. MANIFOLD #A	1
76	70125-41030	PLATE, OUTLET VALVE	1
77	701212A1-41001	OUTLET, VALVE ASSY.	3
78	701212A1-31000	INLET, VALVE ASSY.	3
79	701312A1-66000	AIR STRAINER ASSY.	3
80	701208A1-66110	AIR STRAINER FILTER	3

AIR COOLED TWO STAGE MODELS E-11 & E-23

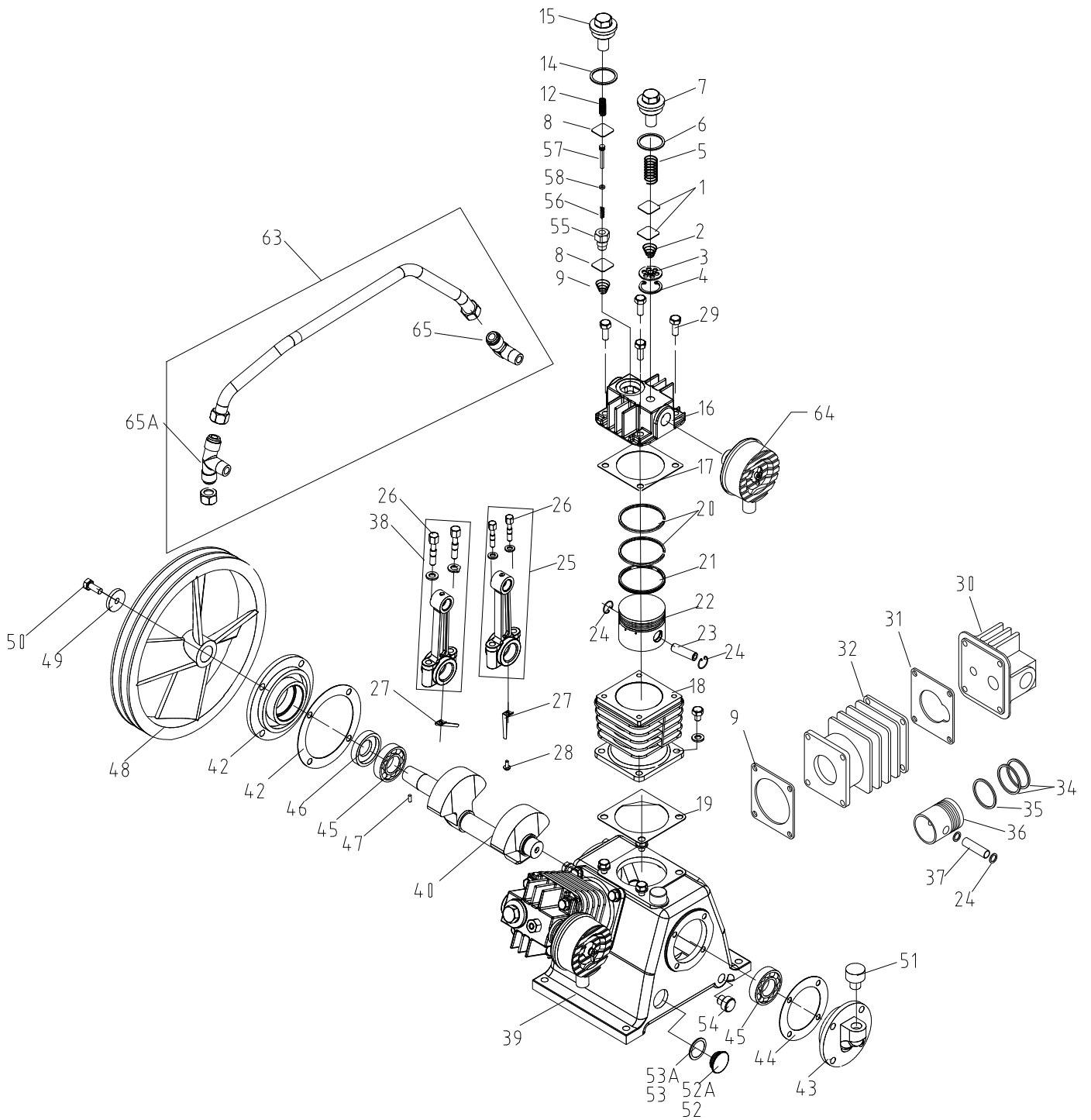

MAIN PARTS LISTING FOR TWO STAGE MODELS E-11 & E-23

VALVES		Qty. Req.	MODEL E11	Qty. Req.	MODEL E23
1.	Inlet & Outlet Valve Plate (1 st)	2	70112-31030	4	70112-31030
2.	Inlet Valve Spring (1 st)	1	70112-31070	2	70112-31070
3.	Inlet Valve Receiver (1 st)	1	70112-31020	2	70112-31020
4.	Inlet Valve Snap Ring (1 st)	1	93610-130232	2	93610-130232
5.	Outlet Valve Spring (1 st)	1	70112-41070	2	70112-41070
6.	Outlet Valve Push Cover Gasket (1 st)	1	70112-11461	2	70112-11461
7.	Outlet Valve Push Cover	1	70112-11450	2	70112-11450
8.	Inlet & Outlet Valve Plate (2 nd)	2	70162-32030	2	70111-31030
9.	Inlet Valve Spring (2 nd)	1	70162-32070	2	70172-32070
10.	Inlet Valve Receiver (2 nd)	1	70162-32020	1	70111-31020
11.	Inlet Valve Snap Ring (2 nd)	1	93610-130222	1	93610-130225
12.	Outlet Valve Spring (2 nd)	1	70162-42070	1	70172-42070
14.	Outlet Valve Push Cover Gasket (2 nd)	1	70162-12650	1	70111-11461
15.	Outlet Valve Push Cover (2 nd)	1	70112-12450	1	70111-11450
CYLINDERS					
16.	Cylinder Head (1 st)	1	70112-11010	2	70112-11010
17.	Cylinder & Head Gasket (1 st)	1	70112-11612	2	70112-11612
18.	Cylinder (1 st)	1	70112-51010	2	70112-51010
19.	Cylinder & Case Gasket	2	70112-51610	3	70112-51610
20.	Compression Ring (1 st)	2	70112-61030	4	70112-61030
21.	Oil Control Ring (1 st)	1	70112-61050	2	70112-61050
22.	Piston (1 st)	1	70112-61011	2	70112-61011
23.	Piston Pin (1 st)	1	70112-61120	2	70112-61120
24.	Piston Pin Snap Ring	4	70112-61070	6	70112-61070
25.	Connecting Rod Assembly (1 st)	2	70112-61200-1	2	70112-61200-1
26.	Connecting Rod Bolt	2	70112-61250	3	70112-61250
27.	Oil Splash Dipper		70122-61282	2	70122-61282
27A.	Oil Splash Dipper		-	1	70132-61290
28.	Oil Splash Dipper Bolt	2	91507-2304010	3	91507-2304010
29.	Cylinder Head Bolt	8	91501-1308025	12	91501-1308025
30.	Cylinder Head (2 nd)	1	70162-12010	1	70172-12010
31.	Cylinder & Head Gasket (2 nd)	1	70162-12610	1	70111-11612
32.	Cylinder (2 nd)	1	70162-52010	1	70172-52010
34.	Compression Ring (2 nd)	2	70162-62030	2	70111-61030
35.	Oil Control Ring (2 nd)	2	70162-62050	2	70111-61050
36.	Piston (2 nd)	1	70162-62010	1	70172-62010-1
37.	Piston Pin (2 nd)	1	70162-62120	1	70172-62120
38.	Connecting Rod Assembly (2 nd)		-	1	70182-62200
CRANK ASSEMBLY					
39.	Crankcase	1	70122-57010-4024	1	70132-57010-4024
40.	Crankshaft	1	70122-56010	1	70132-56010
41.	Front Bearing Cover	1	70122-57030	1	70122-57030
42.	Front Bearing Cover Gasket	1	70122-57950	1	70122-57950
43.	Rear Bearing Cover	1	70122-57060	1	70122-57060
44.	Rear Bearing Cover Gasket	1	70122-57960	1	70122-57960
45.	Bearing	2	93501-6205	2	93501-6205
46.	Front Oil Seal	1	70122-57080	1	70122-57080
47.	V-Pulley Pin	1	70112-56060	1	70112-56060
48.	Compressor Pulley	1	70122-76011	1	70132-76010
49.	Compressor Pulley Thrust Washer	1	70112-76210	1	70112-76210
50.	Compressor Pulley Thrust Bolt	1	91501-1308025	1	91501-1308025
51.	Breather Assembly	1	CCC1375	1	CCC1375
52.	Oil Gauge & Gauge Cover	1	70111-57700	1	70111-57700
52*A.	Oil Level Gauge Assy.	1	70A109B1-57701	1	70704-57700
53.	Gauge Cover Seal	1	70111-57730	1	70111-57730
53*A.	Oil Level Gauge "O" Ring	1	93602-8126026	1	93602-8126026
54.	Crankcase Oil Plug	1	90112-100202	1	90112-100202
54A.	Oil fill cap		-	1	70101-57190-4010
54B.	"O" Ring		-	1	93601-810016
UNLOADERS					
55.	Auto-Unloader Assembly	2	70112-11201	3	70112-11201
56.	Auto-Unloader Spring	2	70112-11230	3	70112-11230
57.	Auto-Unloader Piston	2	70112-11221	3	70112-11221
58.	O-Ring (Unloader)	2	93601-810016	3	93601-810016
AIR STRAINER ASSEMBLY					
61.	Air Strainer Filter (not shown)	1	70111-66141	2	70111-66141
63A.	Discharge Piping Assembly		-	1	70132-87100
63B.	Discharge Piping Assembly	1	70172-87300	1	70172-87300
64.	Air Strainer Assembly	1	70111-66001	2	70111-66001
65.	Outlet Pipe Joint #A	2	70122-87010	3	70122-87010
65A.	Outlet Pipe Joint #B			1	70132-87020

- E11, START S/N AS4040633
- E23, START S/N AS4030313

AIR COOLED, TWO STAGE MODELS E-50 & E-71

CAP600

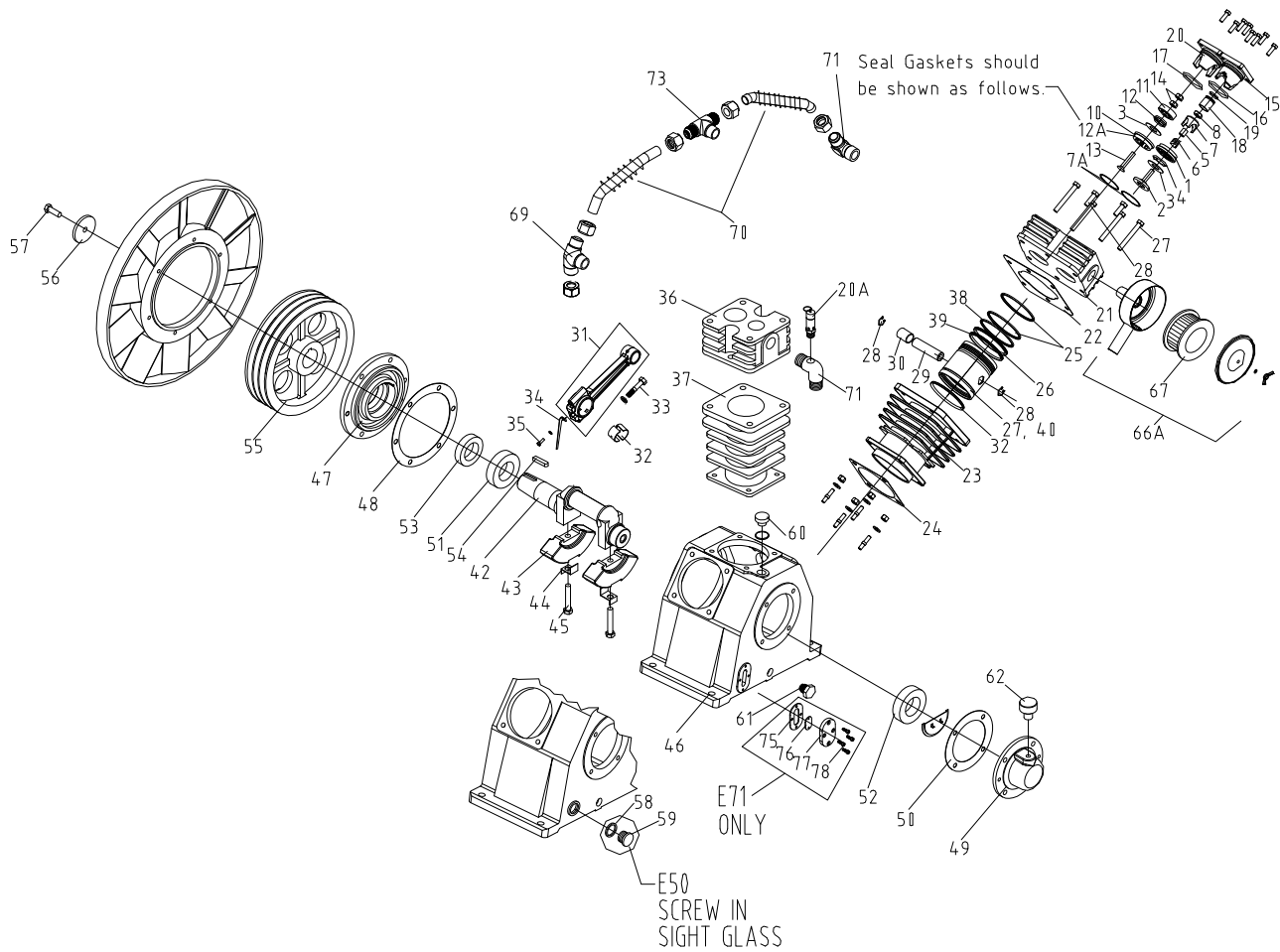

VALVE ASSEMBLIES	DESCRIPTIONS	Qty. Req.	MODEL E50	Qty. Req.	MODEL E71
	Inlet Valve Assembly, 1 st Stage	2	70123-31000	2	70124-31000
Inlet Valve Assembly, 2 nd Stage	1	70173-32000	1	70173-32000	
Outlet Valve Assembly, 1 st Stage	2	70123-41000	2	70124-41000	
Outlet Valve Assembly, 2 nd Stage	1	70123-41000	1	70123-41000	
Breather Assembly	1	70103-57600-4024	1	70124-57600-4010	

MAIN PARTS LISTING FOR TWO STAGE MODELS E-50 & E-71

DESCRIPTIONS	MODEL E50				MODEL E71			
	Qty Req'd	1 st Stage	Qty Req'd	2 nd Stage	Qty Req'd	1 st Stage	Qty Req'd	2 nd Stage
1. Inlet Valve Seat	2	70123-31010	1	70123-31010	2	70124-31010	1	70123-31010
2. Inlet Valve Receiver	2	70123-31020	1	70123-31020	2	70124-31020	1	70123-31020
3. Inlet & Outlet Valve Plate	4	70123-31030	2	70123-31030	4	70124-31030	2	70123-31030
4. Inlet Valve Spring	2	70123-31070	1	70123-31070	2	70124-31070	1	70123-31070
5. Inlet Valve Unloading Fork Guide	2	70123-31090	1	70123-31090	2	70124-31090	1	70123-31090
6. Unloading Spring	2	70123-11230	1	70123-11230	2	70124-11230	1	70123-11230
7. Inlet Valve Unloading Fork	2	70123-31080	1	70123-31080	2	70124-31080	1	70123-31080
8. Slotted Nut	2	92502-230800	1	92502-230800	2	92502-230800	1	92502-230800
9. Cotter Pin (not shown)	2	93701-130220	1	93701-130220	2	93701-130220	1	93701-130220
10. Outlet Valve Seat	2	70123-41011	1	70123-41011	2	70124-41011	1	70123-41011
11. Outlet Valve Receiver	2	70123-41020	1	70123-41020	2	70124-41020	1	70123-41020
12A. Seat Gaskets	4	70123-11110	2	70123-11110	4	70124-11110	2	70123-11110

MAIN PARTS LISTING FOR TWO STAGE MODELS E-50 & E-71 (CONTINUED)

			MODEL E-50				MODEL E-71			
DESCRIPTION			QTY	1 st Stage	QTY	2 nd Stage	QTY	1 st Stage	QTY	2 nd Stage
Valves & Unloaders	12B	Outlet Valve Spring	2	70123-41070	1	70123-41070	2	70124-41070	1	70123-41070
	13	Outlet Valve Bolt	2	70123-41810	1	70123-41810	2	70124-41810	1	70123-41810
	14	Nut (Outlet Valve)	2	92502-230800	1	92502-230800	2	92502-230800	1	92502-230800
	15	Inlet Valve Push Cover	2	70123-11150	1	70123-11150	2	70124-11150	1	70123-11150
	16	O-ring G-40(Inlet Valve)	2	93602-810040	1	93602-810040	2	93602-810055	1	93602-810055
	17	Viton O-ring G-40 (Outlet Valve)	2	93602-870040	1	93602-870040	2	93602-870055	1	93602-870040
	18	Unloading Piston	2	70123-11220	1	70123-11220	2	70124-11220	1	70123-11220
	19	O-ring P-20	2	93601-810020	1	93601-870020	2	93601-810021	1	93601-870020
	20	Outlet Valve Push Cover	2	70123-11450	1	70123-11450	2	70124-11450	1	70123-11450
	20A	Interstage Safety Valve (E71 only)	-	N/A	-	N/A	1	93132-15006-40101	-	N/A
Cylinders	21	Cylinder Head (1 st)	2	70123-11010			2	70124-11010		
	22	Cylinder & Head Gasket	2	70123-11612	1	70123-11612	2	70124-11612	1	70123-11612
	23	Cylinder (1 st)	2	70123-51012			2	70124-51011		
	23A	S/N A311xxxx & Later Use	2	70123-51012			2	70124-51011		
	24	Cylinder & Case Gasket	2	70123-51610	1	70123-51610	2	70124-51610	1	70124-51610
	25	Compression Ring (1 st)	4	70123-61030			4	70124-61030		
	26	Oil Control Ring (1 st)	4	70123-61050			4	70124-61050		
	27	Piston (1 st)	2	70123-61011			2	70124-61011-1		
	27A	S/N 3020000 & Later Use	2	70123-61011			2	70124-61011-1		
	28	Piston Snap Ring	4	70123-61070	2	70123-61070	4	70124-61070	2	70124-61070
	29	Piston Pin (1 st)	2	70123-61120			2	70124-61120		
	30	Con'cting Rod Pist. Pin Bushing	2	70123-61081	1	70173-62080	2	70124-61080	1	70174-62081
	30A	Bushing S/N 3020000 & Later use	2	70123-61081						
	30B	Nedl Brg.S/N A303XXXX&LatrUse							1	93503-RNA6903R
	30C	Nedl Brg.(2 nd)/S/N A405XXXX&Latr			1	93503-TA1725				
	31	Connecting Rod Assy	2	70123-61200	1	70173-62200	2	70124-61201	1	70174-62202
	31B	Conn. Rod Assy., 2 nd Stage S/N A405XXXX & Later Use			1	70173-62200				
	32	Connecting Rod Crank Pin Metal	4	70123-61090	2	70123-61090	4	70124-61090	2	70124-61090
	33	Connecting Rod Bolt	4	70125-61250	2	70125-61250	4	70125-61250	2	70125-61250
	34	Oil Splash Dipper	2	70122-61282	1	70132-61290	2	70134-61281	1	70134-61290
	35	Oil Splash Dipper Bolt	2	91507-2304012	1	91507-2304012	2	91507-2304012	1	91507-2304012
	36	Cylinder Head (2 nd)			1	70123-11010			1	70174-12010
	37	Cylinder (2 nd)			1	70173-52010			1	70174-52011
	37A	Cyl (2 nd),S/N 3020000 & Later Use							1	70174-52011
	38	Compression Ring (2 nd)			3	70112-61030			3	70123-61030
	39	Oil Control Ring (2 nd)			1	70112-61050			2	70123-61050
	40	Piston (2 nd)			1	70173-62010-1			1	70174-62010-1
41	Piston Pin (2 nd)			1	70173-62120			1	70174-62120	
Crankcase & Crank Assembly	42	Crankshaft	1	70133-56011			1	70134-56010		
	43	Crankshaft, Counterweight		-			1	70134-56030		
	44	Counterweight Lock Washer		-			2	70124-56830		
	45	Counterweight Mtg. Bolt		-			2	70124-56810		
	46	Crankcase	1	70133-57010-4024			1	70134-57010-4024		
	47	Front Bearing Cover	1	70133-57030			1	70134-57030		
	48	Front Bearing Cover Gasket	1	70123-57950			1	70124-57950		
	49	Rear Bearing Cover	1	70133-57061			1	70134-57061		
	49A	Rear Brg Cvr, S/N 3020000 & Later	1	70133-57061			1	70134-57061		
	50	Rear Brg Cvr Gasket	1	70133-57960			1	70134-57960		
	51	Front Bearing	1	93501-6306			1	93502-32210		
	52	Rear Bearing	1	93501-6306			1	93502-32210		
	53	Front Oil Seal	1	70123-57080			1	70134-57080		
	54	V-Pulley Pin	1	70123-56061			1	70134-56060		
	55A	Compressor Fan		-			1	70124-76310		
	55B	Compressor Pulley	1	70133-76010			1	70134-76011		
	56	Compressor Pulley Washer	1	92521-232000			1	70124-76210		
	57	Compressor Pulley Set Bolt	1	91501-1312030			1	91501-1312040		
	58	O-Ring (Oil Level Glass)	1	93602-81260-3065	-	-	-	-		
	59	Screw In Oil Level Glass	1	70A109B1-57702	-	-	-	-		
	60	Crankcase Oil Cap	1	CCC1257			1	CCC1257		
	61	Crankcase Oil Plug	1	90112-100404			1	90112-100404		
	62	Breather Assembly	1	CCC1375			1	CCC1258		
	66A	Air Strainer Assembly	2	70123-66000			2	70123-66000		
	67	Air Strainer Filter	2	70123-66140			2	70123-66140		
	69	Outlet Pipe Joint B	1	70123-87020			1	70174-87020		
	70A	Comp.body.discharg.pipe.assy. 1 st	1	70133-87101 short			1	70134-87101 short		
	70B	Comp.body.discharg.pipe.assy. 1 st		-				-		
70C	Comp.body.discharg.pipe.assy.2nd		-				-			
70D	Comp.body.discharg.pipe.assy.2nd	1	70173-87300 long			1	70174-87300 long			
71	Outlet Pipe Joint A	2	70123-87010			3	70124-87010			
72	Outlet Pipe Joint D	1	70173-87010							
73	Outlet Pipe Joint C		-				-			
74	Gasket Manifold		-				-			
75	Oil Level Glass Gasket	1	701210A1-57730			1	701210A1-57730			
76	Oil Level Glass Assembly	1	701210A1-57700			1	701210A1-57700			
77	Oil Level Glass Push Cover	1	701210A1-57740			1	701210A1-57740			
78	Screw, Metric Pan Head	4	VH1470			4	VH1470			

AIR COOLED, TWO STAGE MODEL E-15

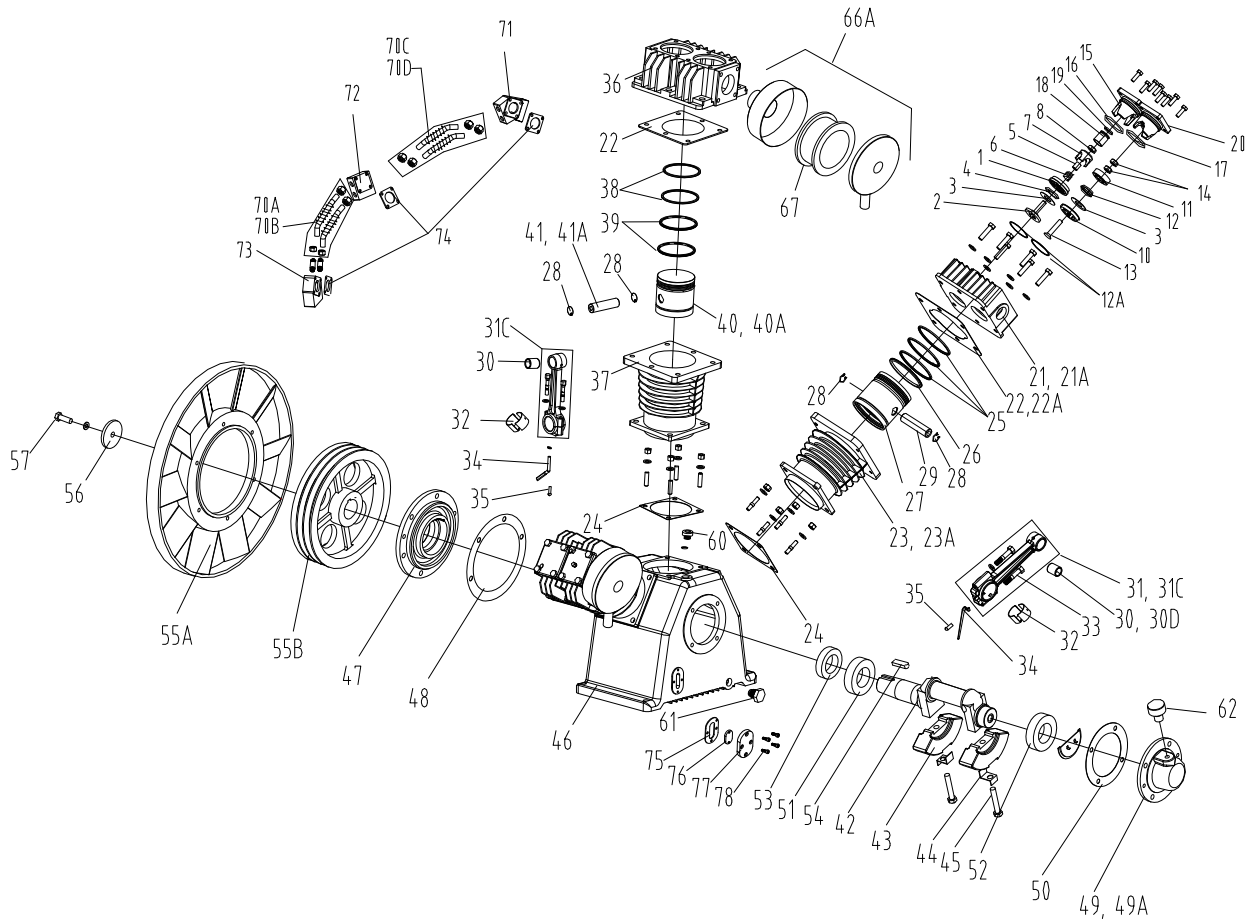

VALVE ASSEMBLIES	Description	Qty. Req.	MODEL E15
	Inlet Valve Assembly, 1 st Stage	2	70125-31000
	Inlet Valve Assembly, 2 nd Stage	1	70175-32000
	Outlet Valve Assembly, 1 st Stage	2	70125-41000
	Outlet Valve Assembly, 2 nd Stage	1	70175-42000
Breather Assembly	1	70124-57600-4010	

MAIN PARTS LISTING FOR TWO STAGE MODEL E-15

Description	MODEL E15			
	Qty Req'd	1 st Stage	Qty Req'd	2 nd Stage
1. Inlet Valve Seat	2	70125-31010	1	70124-31010
2. Inlet Valve Receiver	2	70125-31022	1	70124-31020
3. Inlet & Outlet Valve Plate	4	70125-31030	2	70175-42030
4. Inlet Valve Spring	2	70125-31070	1	70124-31070
5. Inlet Valve Unloading Fork Guide	2	70125-31090	1	70124-31090
6. Unloading Spring	2	70125-11230	1	70124-11230
7. Inlet Valve Unloading Fork	2	70125-31080	1	70124-31080
8. Slotted Nut	2	92502-230800	1	92502-230800
9. Cotter Pin (not shown)	2	93701-130220	1	93701-130220
10. Outlet Valve Seat	2	70125-41011	1	70124-41010
11. Outlet Valve Receiver	2	70125-41021	1	70175-42020
12A. Seat Gaskets	4	70125-11110	2	70124-11110

MAIN PARTS LISTING FOR TWO STAGE MODEL E-15 (Continued)

DESCRIPTION		MODEL E15				
		Qty Req'd	1 st Stage	Qty Req'd	2 nd Stage	
VALVES & UNLOADERS	12B. Outlet Valve Spring	2	70125-41071	1	70124-41072	
	13. Outlet Valve Bolt	2	70124-41810	1	70124-41810	
	14. Nut (Outlet Valve)	2	92501-231000	1	92501-231000	
	15. Inlet Valve Push Cover	2	70125-11151	1	70175-12150	
	16. O-Ring G-65 (Inlet Valve)	2	93602-810065	1	93602-870055	
	17. Viton O-Ring G-65 (Outlet Valve)	2	93602-870065	1	93602-870055	
	18. Unloading Piston	2	70125-11220	1	70124-11220	
	19. O-Ring P-20	2	93601-810022A	1	93601-870021	
	20. Outlet Valve Push Cover	2	70125-11451	1	70175-12450	
	20A. Outlet Valve Push Cover Push Pipe	1	70124-11120			
CYLINDERS	21. Cylinder Head (1 st)	2	70125-11010			
	21A. S/N A31XXXX & Later Use	2	70135-11010			
	22. Cylinder & Head Gasket	2	70125-11612	1	70124-11612	
	22A. S/N A31XXXX & Later Use	2	70135-11612			
	23. Cylinder (1 st)	2	70125-51010			
	23A. S/N A311xxxx & Later Use	2	70135-51011			
	24. Cylinder & Case Gasket	2	70135-51610			
	25. Compression Ring (1 st)	4	70125-61030			
	26. Oil Control Ring (1 st)	4	70125-61050			
	27. Piston (1 st)	2	70135-61010-1			
	27A. S/N 3020000 & Later Use	2	70135-61010-1			
	28. Piston Snap Ring	4	70125-61070	2	70125-61070	
	29. Piston Pin (1 st)	2	70125-61120			
	30. Connecting Rod Piston Pin Bushing (1 st)	2	70125-61081	1	70175-62080	
	30D. Needle Bearing (2 nd) S/N A409XXXX & Later Use			1	93503-NK28/30	
	31. Connecting Rod Assembly, 1 st Stage	2	70125-61200	1	70175-61200	
	31C. Connecting Rod Assembly, 2 nd Stage			1	70175-62201	
	32. Connecting Rod Crank Pin Metal	4	70125-61090	2	70125-61090	
	33. Connecting Rod Bolt	4	70125-61250	2	70125-61250	
	34. Oil Splash Dipper	2	70135-61281	1	70135-61281	
	35. Oil Splash Dipper Bolt	2	92501-130800	1	92501-130800	
	36. Cylinder Head (2 nd)			1	70175-12010	
	37. Cylinder (2 nd)			1	70175-52010	
	38. Compression Ring (2 nd)			3	70124-61030	
	39. Oil Control Ring (2 nd)			2	70124-61050	
	40. Piston (2 nd)			1	70175-62010-1	
	40A. Piston (2 nd), S/N A409XXXX & Later Use			1	70175-62011-1	
	41. Piston Pin (2 nd)			1	70175-62120	
	41A. Piston Pin (2 nd), S/N A409XXXX & Later Use			1	70175-62121	
	CRANKCASE AND CRANK ASSEMBLY	42. Crankshaft	1	70135-56011		
		43. Crankshaft Counterweight	1	70135-56030		
44. Counterweight Lock Washer		2	70124-56830			
45. Counterweight Mounting Bolt		2	70135-56811			
46. Crankcase		1	70135-57010-4024			
47. Front Bearing Cover		1	70135-57030			
48. Front Bearing Cover Gasket		1	70135-57950			
49. Rear Bearing Cover		1	70134-57061			
49A. Rear Bearing Cover, S/N 3020000 & Later Use		1	70134-57061			
50. Rear Bearing Cover Gasket		1	70134-57960			
51. Front Bearing		1	93502-30310			
52. Rear Bearing		1	93502-32210			
53. Front Oil Seal		1	70134-57080			
54. V-Pulley Pin		1	70134-56060			
55A. Compressor Fan		1	70135-76310			
55B. Compressor Pulley		1	70135-76011			
56. Compressor Pulley Washer		1	70135-76210			
57. Compressor Pulley Set Bolt		1	91501-1312050			
60. Crankcase Oil Cap		1	CCC1257			
61. Crankcase Oil Plug		1	90112-100404			
62. Breather Assembly		1	70124-57600-4010			
66A. Air Strainer Assembly		2	70123-66000			
67. Air Strainer Filter		2	70123-66140			
69. Outlet Pipe Joint B		1	70175-87021			
70A. Compressor Body Discharge Piping Assembly, 1 st		1	70135-87100(long)			
70B. Compressor Body Discharge Piping Assembly, 1 st		1	70135-87200(short)			
70C. Compressor Body Discharge Piping Assembly, 2 nd		1	70175-87400(short)			
70D. Compressor Body Discharge Piping Assembly, 2 nd		1	70175-87300(long)			
71. Outlet Pipe Joint A		1	70175-87010			
72. Outlet Pipe Joint D (not shown)		1	70125-87020			
73. Outlet Pipe Joint C		1	70175-87030-4010			
74. Gasket Manifold	4	70125-87510				
75. Oil Level Glass Gasket	1	701210a1-57730				
76. Oil Level Glass Assembly	1	701210a1-57700				
77. Oil Level Glass Push Cover	1	701210a1-57740				
78. Screw, Metric Pan Head	4	VH1470				

AIR COOLED, TWO STAGE

MODEL E-25

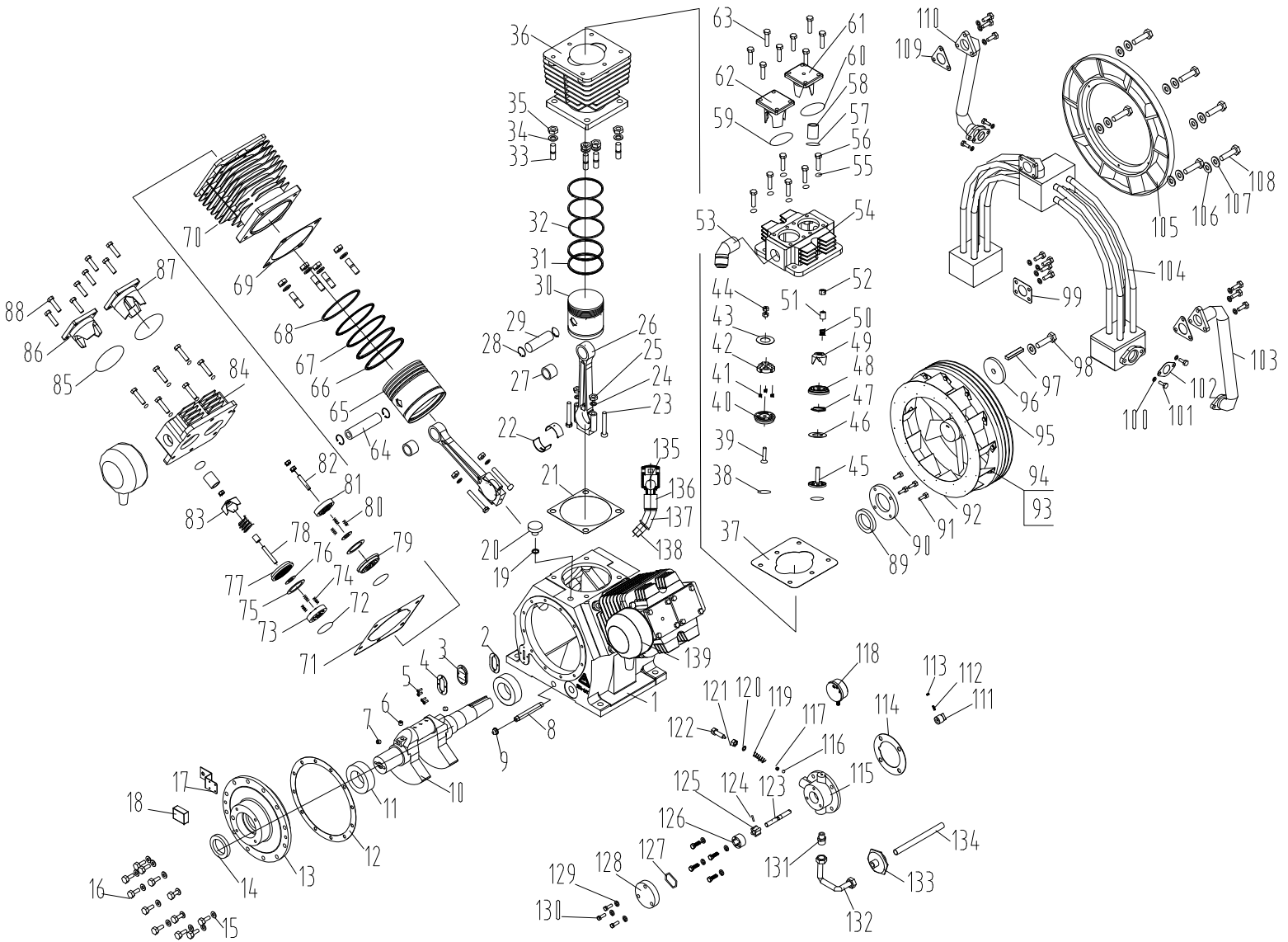

MAIN PARTS LISTING FOR TWO STAGE MODEL E-25

Item No.	Description	Model E-25			
		Qty Req.	1 st Stage	Qty Req.	2 nd Stage
1	CRANKCASE	1	70131EB2-57010		
2	OIL SIGHT GLASS GASKET	1	70124-57730		
3	OIL SIGHT GLASS ASSY.	1	70124-57700		
4	OIL SIGHT GLASS PUSH COVER	1	70124-57740		
5	OIL SIGHT GLASS BOLT; M5 x L20, Gr.8.8	4	91507-2305020		
6	BOLT M12*1.25*L10	1	9152813-1Z12010		
7	OIL NOZZLE	2	703213A1-561070		
8	PIPE	1	9011023-1604604		
9	PIPE CAP	1	9092017-1304000		
10	CRANK SHAFT	1	70131EB2-56010		
11	FRONT & REAR BEARING	2	93501-33112		
12	REAR BEARING COVER GASKET	1	70178-57070		
13	REAR BEARING COVER	1	70131EB2-57060		
14	REAR OIL SEAL	1	70131EB2-57090		
15	CENTRIFUGAL FAN LOCK WASHER; M10	12	92521-231000		
16	CENTRIFUGAL FAN BOLT; M10 X L30, Gr.8.8	12	91501-2310030-8		
17	FIX PLATE	1	70131EB2-57930		
18	PRESSURE SWITCH	1	93301-990005		
19	O-RING (OIL FILL CAP)	1	93601-810018		
20	OIL FILL CAP	1	70123-57190		
21	CYLINDER – CASE GASKET (2 ND)			1	70178-52030
22	CONNECTING ROD CRANK PIN	6	70178-61090		
23	CONNECTING ROD BOLT	6	70178-61250		
24	LOCKWASHER (M12)	6	92522-131200		
25	NUT; (M12)	6	92501-131200-8		
26	CONNECTING ROD	3	70131EB2-61210		
27	CONNECTING ROD – PISTON PIN NEEDLE BEARING	3	93501-3230		
28	PISTON PIN SNAP RING	6	93610-130032		
29	PISTON (2 ND)			1	70131EB2-62120
30	PISTON (2 ND)			1	70131EB2-62010
31	OIL CONTROL RING (2 ND)			2	70178-62050
32	COMPRESSION RING (2 ND)			3	70178-62030
33	CYLINDER BOLT (1 ST); M16 x L46, Gr. 8.8	12	91525-1316045-8		
34	CYLINDER LOCK WASHER; M16 x L46, Gr. 8.8	13	92522-131600		
35	CYLINDER NUT; M16	12	92501-131600		
36	CYLINDER (2 ND)			1	70178-52010
37	VALVE – CYLINDER GASKET (2 ND)			1	70178-31240
38	INLET & OUTLET VALVE GASKET (2 ND)			2	70125-11110
39	OUTLET VALVE BOLT; M10 X L50, Gr. 8.8	1	9152613-1110050		
40	OUTLET VALVE SEAT (2 ND)			1	70125-41011
41	OUTLET VALVE SPRING (2 ND)			3	70125-41074
42	OUTLET VALVE RECEIVER (2 ND)			1	701212A1-41026
43	OUTLET VALVE PLATE (2 ND)			1	501212A1-41032
44	NUT; M10 (Outlet Valve)	6	92501-231000		
45	INLET VALVE RECEIVER (2 ND)			1	70125-31023
46	INLET VALVE PLATE (2 ND)			1	50125-31030
47	INLET VALVE SPRING (2 ND)			1	70125-31070
48	INLET VALVE SEAT (2 ND)			1	70125-31010
49	INLET VALVE UNLOADER FORK (2 ND)			1	70125-31080
50	UNLOADER SPRING	3	70125-11230		

**MAIN PARTS LISTING FOR
TWO STAGE MODEL E-25**

CAP600

Item No.	Description	Model E-25			
		Qty Req	1 st Stage	Qty Req	2 nd Stage
51	INLET VALVE UNLOADER FORK GUIDE	1	70125-31090		
52	LOCKNUT; M12 (Inlet Valve)	1	92517-231200		
53	AIR OUTLET JOINT	1	70131EB1-87021		
54	CYLINDER HEAD (2 ND)			1	70181EB3-12010
55	CYLINDER HEAD BOLT SPRING WASHER; M12	18	92522-131200		
56	CYLINDER HEAD BOLT; M12 x L35; Gr. 8.8	18	9150113-1112035		
57	O-RING P 22A (Unloader)	3	93601-870022A		
58	UNLOADER PISTON	3	70125-11220		
59	O-RING G65 (Outlet Valve)	1	93602-870065		
60	O-RING G65 (Inlet Valve)	1	93602-810065		
61	INLET VALVE PUSH COVER (2 ND)			1	70125-11151
62	OUTLET VALVE PUSH COVER (2 ND)			1	70125-11451
63	OUTLET VALVE PUSH COVER BOLT; M10 x L25, Gr. 8.8	8	91501-1310025-8		
64	PISTON PIN (1 ST)	2	70178-61120		
65	PISTON (1 ST)	2	70131EB2-61010		
66	OIL CONTROL RING (1 ST)	4	70178-61050		
67	COMPRESSION RING 2 (1 ST)	4	70178-61030-2		
68	COMPRESSION RING 1 (1 ST)	2	70178-61030-1		
69	CYLINDER – CASE GASKET (1 ST)	2	70178-51030		
70	CYLINDER (1 ST)	2	70181EB3-51010		
71	VALVE - CYLINDER GASKET (1 ST)	2	70181EB3-11202		
72	INLET & OUTLET VALVE GASKET (1 ST)	4	70181EB3-31110		
73	INLET VALVE RECEIVER (1 ST)	2	70181EB3-31020		
74	INLET VALVE SPRING (1 ST)	6	70181EB3-31070		
75	INLET VALVE PLATE 1 (1 ST)	2	70181EB3-31050		
76	INLET VALVE PLATE 2 (1 ST)	2	70181EB3-31030		
77	INLET VALVE SEAT (1 ST)	2	70181EB3-31010		
78	INLET VALVE STUD	2	70181EB3-31810		
79	OUTLET VALVE SEAT (1 ST)	2	70181EB3-41010		
80	OUTLET VALVE SPRING (1 ST)	6	70181EB3-41070		
81	OUTLET VALVE RECEIVER (1 ST)	2	70181EB3-41020		
82	OUTLET VALVE STUD	2	70131BA4-41810		
83	INLET VALVE UNLOADER FORK (1 ST)	2	70181EB3-31080		
84	CYLINDER HEAD (1 ST)	2	70181EB3-11010		
85	O-RING G85.7	2	9360287-310857		
86	INLET VALVE PUSH COVER (1 ST)	2	70181EB3-11150		
87	OUTLET VALVE PUSH COVER (1 ST)	2	70181EB3-11450		
88	OUTLET VALVE PUSH COVER BOLT; M10 x L30, Gr. 8.8	16	CT55-1310030		
89	OIL SEAL	1	70178-57080		
90	FRONT OIL SEAL PUSH COVER	1	70178-57240		
91	FRONT OIL SEAL PUSH COVER BOLT; M8 x L25, Gr. 8.8	4	91501-2308025-8		
92	CENTRIFUGAL FAN	1	70A81EB1-76300		
93	LOCK WASHER, M6	12	92522-130600		
94	BOLT; M6 x L10, Gr. 8.8	12	91513-1306010		
95	COMPRESSOR PULLEY	1	70178-76010		
96	COMPRESSOR PULLEY THRUST WASHER	1	70178-76210		
97	V-PULLEY PIN	1	70718-56060		
98	COMPRESSOR PULLEY BOLT; M16 x L30, Gr. 8.8	1	91501-2316045-8		
99	INTERCOOLER – HEAD GASKET	1	70178-71020		
100	PIPING-INTERCOOLER LOCK WASHER; M10	14	92522-13100		

**MAIN PARTS LISTING FOR
TWO STAGE MODEL E-25**

CAP600

Item No.	Description	Model E-25			
		Qty Req	1 st Stage	Qty Req	2 nd Stage
101	PIPING-INTERCOOLER BOLT; M10 x L30, Gr. 8.8	14	91513-1310030-8		
102	PIPING- INTERCOOLER GASKET	2	70178-87090		
103	DISCHARGE PIPING ASSEMBLY	1	70178-87100		
104	MIDDLE INTERCOOLER ASSEMBLY	1	70131EB1-71000C		
105	COMPRESSOR FAN	1	70178-76310		
106	COMPRESSOR FAN WASHER, M8	6	92521-230800		
107	COMPRESSOR FAN LOCK WASHER, M8	6	92522-130800		
108	COMPRESSOR FAN BOLT; M8 x L30, Gr. 8.8	6	91501-92308030-8		
109	PIPING-HEAD GASKET	2	70178-87130-1		
110	DISCHARGE PIPING ASSEMBLY	1	70178-87200		
111	GEAR PUMP COUPLING	1	703213A1-27110		
112	BOLT; M6*15	1	91501-2306015		
113	NUT; M6	1	92501-130600		
114	GEAR PUMP HOUSING GASKET	1	703213A1-27020		
115	GEAR PUMP HOUSING	1	70131EB2-27010		
116	STEEL BALL	1	9980113-20036		
117	BALL VALVE RECEIVER	1	703213A1-28090		
118	PRESSURE GAUGE (0~10K)	1	9320611-2032213		
119	BALL VALVE SPRING	1	703213A1-28080		
120	REGULATOR SEALING	1	703213A1-28110		
121	REGULATOR ADJUST NUT	1	703213A1-28130		
122	REGULATOR ADJUST BOLT	1	703213A1-28120		
123	GEAR PUMP SHAFT	1	703213A1-27070		
124	DRIVE GEAR RING	1	703213A1-27130		
125	DRIVE GEAR	1	703213A1-27050		
126	DIRVEN GEAR	1	703213A1-27060		
127	O-RING	1	9360281-31044		
128	GEAR PUMP HOUSING COVER	1	70131EB2-27030		
129	LOCK WASHER, M10	3	92522-131000		
130	BOLT; M10*30	3	91501-2310030		
131	COPPER PIPE JOINT	1	7992013-2204050		
132	PUMP CONNECTING TUBE	1	70131EB2-27080		
133	STRAINER PLUG	1	703213A1-28530		
134	FEED OIL FILTER ASSEMBLY	1	703213A1-28500		
135	BREATHER ASSEMBLY (RUBBER)	1	701312A1-57601		
136	BREATHER TUBE	1	70131BA1-57670		
137	ELBOW 45°	1	9010311-1304304		
138	NIPPLE ½	1	9011013-1304304		
139	AIR FILTER ASSEMBLY	2	70178-66000		

AIR COOLED TWO STAGE MODEL E-35

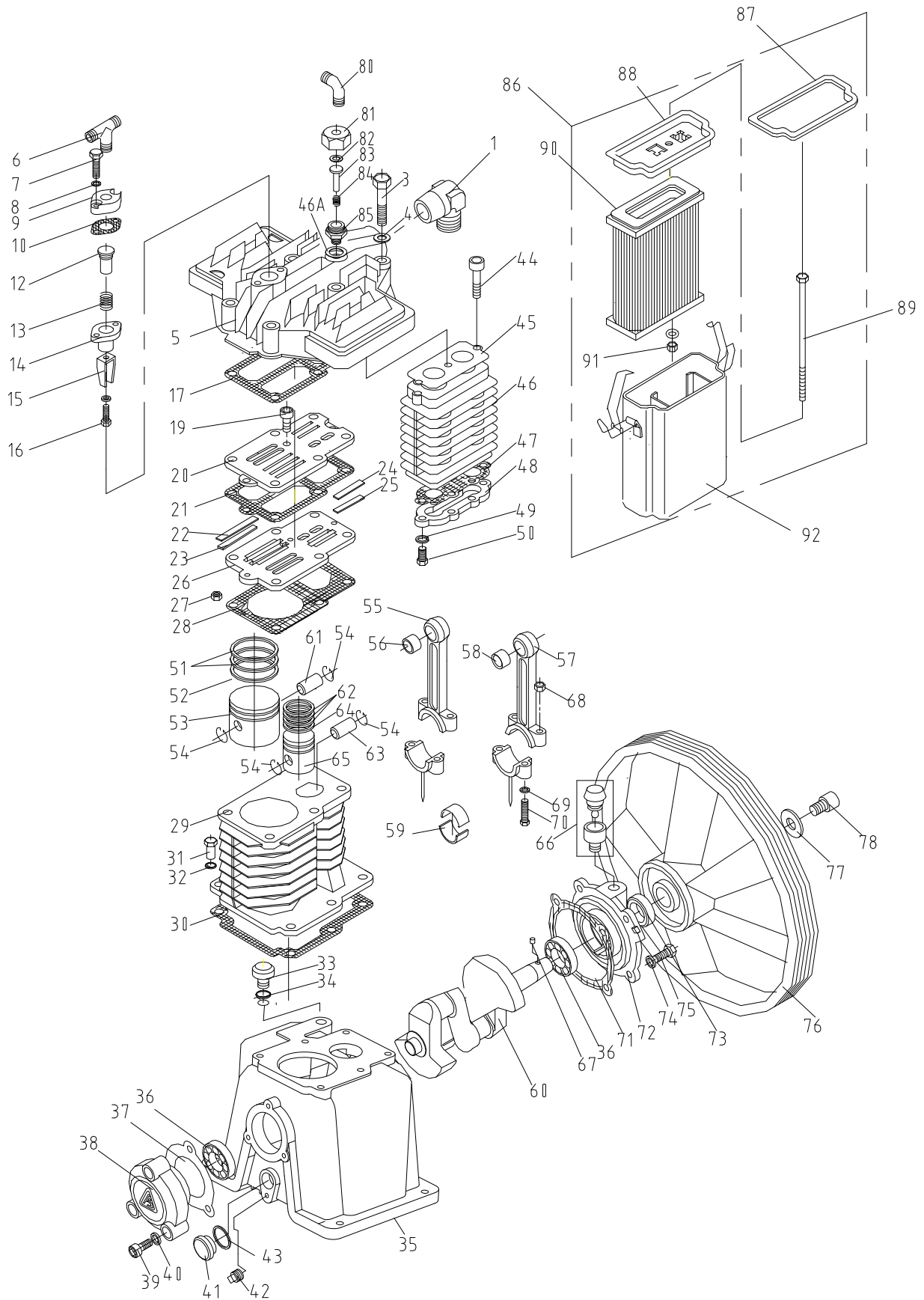

**MAIN PARTS LISTING FOR
AIR COOLED TWO STAGE MODEL E-35
(FORMERLY B-1)**

	DESCRIPTION	QTY	PART NO.
1.	Discharge Elbow	1	70123-87050
2.	Discharge Elbow Nut (Not Shown)	1	79922-130606
3.	Cylinder Head Bolt	6	91501-1310085
4.	Spring Washer	6	92522-130800
5.	Cylinder Head	1	70152-11010
6.	Unloading Tee * #	1	79922-150101
7.	Bolt	2	91521-1306025
8.	Spring Washer	2	92522-130600
9.	Upper Cover	1	70153-11270
10.	Upper Cover Gasket	1	70153-11641
11.	Unloader Assembly (1 st)(Includes 12-16)	1	70152-11201
12.	Unloading Piston	1	70153-11222
13.	Unloading Spring	1	70153-11231
14.	Unloading Cylinder	1	70153-11211
15.	Unloading Fork (1 st)	1	70152-31080
16.	Bolt	1	91501-1306015
17.	Cylinder Head Valve Seat Gasket	1	70152-11612
18.	Valve Plate Assembly (Includes 19-27)	1	70152-31000
19.	Valve Seat Bolt	3	91521-1305012
20.	Valve Seat (Upper)	1	70152-31010
21.	Valve Seat Gasket	1	70152-31120
22.	Valve Plate (1 st)	4	70152-31030
23.	Valve Plate Spring (1 st)	4	70152-31070
24.	Valve Plate (2 nd)	2	70152-32030
25.	Valve Plate Spring (2 nd)	2	70152-32070
26.	Valve Seat (Bottom)	1	70152-31020
27.	Nut	1	92501-230500
28.	Cylinder-Valve Seat Gasket	1	70152-11622
29.	Cylinder	1	70152-51010
30.	Cylinder Crankcase Gasket	1	70152-51610
31.	Bolt	11	91501-1310030
32.	Copper Washer	6	92521-190800
33.	Crankcase Oil Cap	1	70101-57190-4010
34.	Oil Cap O-Ring	1	93601-810016
35.	Crankcase	1	70152-57010
36.	Bearing #6025 (Front & Rear)	2	93501-6205
37.	Rear Cover Gasket	1	70152-57960
38.	Rear Cover	1	70152-57060
39.	Rear Cover Bolt	3	91521-1308030
40.	Copper Washer	7	92521-190800
41.	Oil Level Gauge & Gauge Cover	1	70111-57700
42.	Gauge Cover Seal	1	70111-57730
43.	Crankcase Oil Plug (1/4" NPT)	1	90112-100303
44.	Inter-Cooler Bolt	3	91521-1308050
45.	Gasket	1	70152-71612
46.	Inter-Cooler Body	1	70152-71110
46A.	Gasket, Copper	1	70152-12280

	DESCRIPTION	QTY	PART NO.
47.	Inter-Cooler Body Gasket	1	70152-71622
48.	Inter-Cooler Cover	1	70152-71160
49.	Spring Washer	4	92522-130600
50.	Bolt	4	91501-1306016
51.	Compression Ring (1 st)	2	70152-61030
52.	Oil Control Ring (1 st)	1	70152-61050
53.	Piston (1 st)	1	70152-61010
54.	Piston Snap Ring	4	70152-61070
55.	Connection Rod Assembly (1 st)	1	70152-61200
56.	Piston Pin Bush (1 st)	1	70152-61080
57.	Connecting Rod Assembly (2 nd)	1	70152-62200
58.	Piston Pin Bush (2 nd)	1	70152-62080
59.	Crank Pin Metal (Rod Bearing 2 Halves)	2	70152-61090
60.	Crankshaft	1	70152-56010
61.	Piston Pin (1 st)	1	70152-61120
62.	Compression Ring (2 nd)	3	70152-62030
63.	Piston Pin (2 nd)	1	70152-62120
64.	Oil Control Ring (2 nd)	1	70152-62050
65.	Piston (2 nd)	1	70152-62010
66.	Breather Assembly	1	CCC1375
67.	V-Pulley Pin	1	70112-56060
68.	Nut (Connecting Rod)	4	92501-130800
69.	Spring Washer (Connecting Rod)	4	92522-130800
70.	Bolt (Connecting Rod)	4	70152-61250
71.	Front Cover Gasket	1	70152-57950
72.	Front Cover	1	70152-57030
73.	Front Oil Seal	1	70127-57080
74.	Copper Washer	7	92521-190800
75.	Bolt	4	91501-1310030
76.	Compressor Pulley	1	70152-76010
77.	Compressor Pulley Thrust Washer	1	70112-76210
78.	Bolt	1	91501-1308025
79.	Unloading Elbow * #	1	79926-150101
80.	Unloader Assembly (2 nd)(Includes 81-85)	1	70152-12200
81.	Unloader Cover (2 nd)	1	70103-11271
82.	Viton O-Ring Unloader (2 nd)	1	93601-870009
83.	Unloading Piston (2 nd)	1	70152-12221
84.	Unloading Spring (2 nd)	1	70103-11230
85.	Unloader Body	1	70153-12200
86.	Air Strainer Assembly (Includes 87-92)	1	70152-66001
87.	Air Strainer Cover Gasket	1	70152-66131
88.	Air Strainer Cover	1	70153-66120
89.	Air Strainer Bolt	1	70152-66160
90.	Air Strainer Element	1	70152-66141
91.	Nut (Self Lock) Air Strainer	1	92522-230600
92.	Air Strainer Body	1	70152-66011
93.	Intercooler Safety Valve (Not Shown)	1	VV431

*Includes Nut(S) and Sleeve(S)

#Not Supplied On Basics

AIR COOLED TWO STAGE MODEL E-57, E57A

CAP600

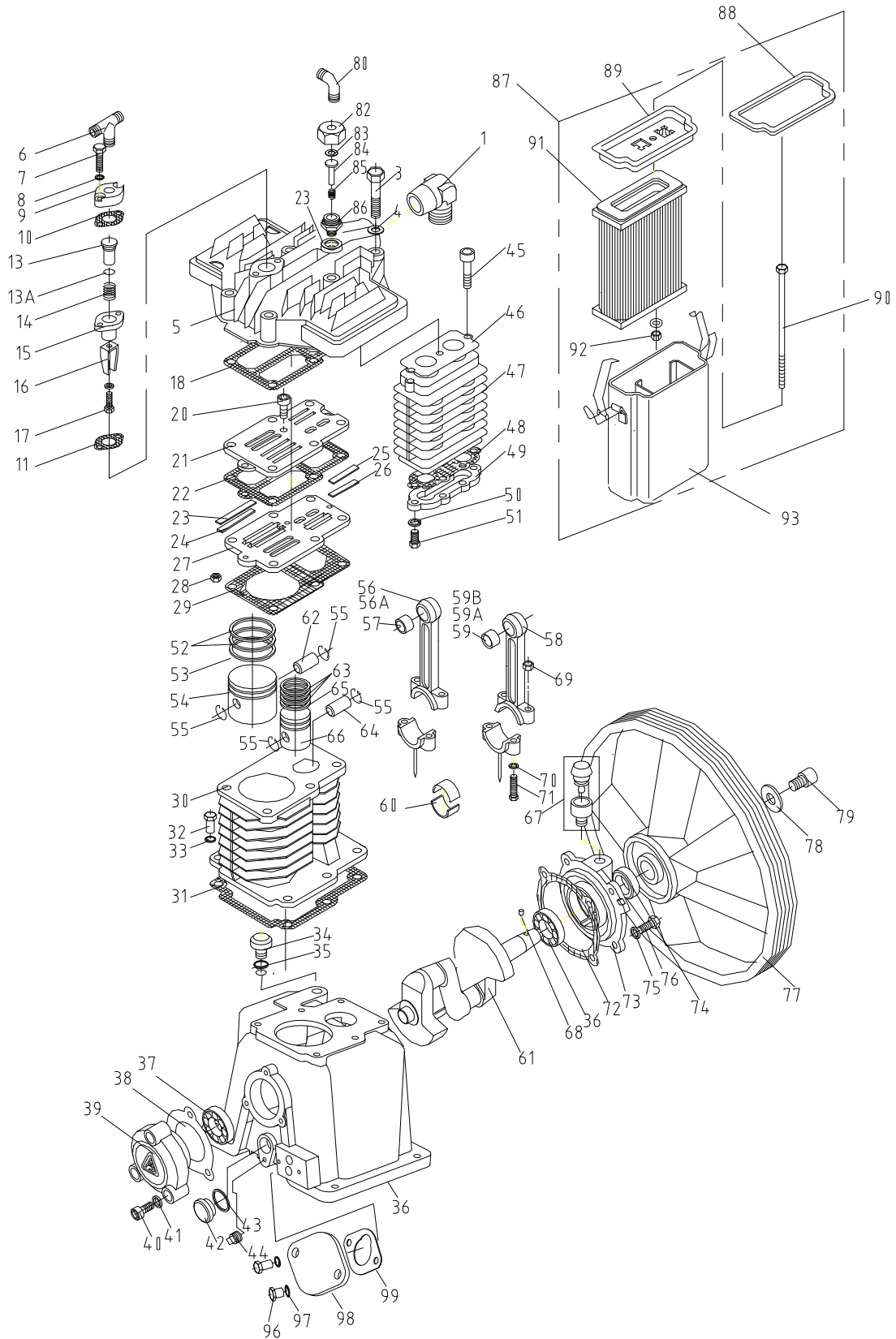

**MAIN PARTS LISTING FOR
AIR COOLED TWO STAGE MODEL E-57 & E-57A
(FORMERLY B-2)**

	DESCRIPTION	QTY	PART NO.
1.	Discharge Elbow	1	VA15EJE
2.	Discharge Elbow Nut (Not Shown)	1	79922-130707
3.	Cylinder Head Bolt	6	91501-1310085
4.	Spring Washer	6	92522-131000
5.	Cylinder Head	1	70153-11011
6.	Unloading Tee * #	1	VA787
7.	Bolt	2	91521-1306025
8.	Spring Washer	2	92522-130600
9.	Upper Cover	1	70153-11270
10.	Upper Cover Gasket	1	70153-11631
11.	Lower Unloader Gasket	1	70153-11641
12.	Unloader Assembly (1 st)(Includes 13-17)	1	70153-11201
13.	Unloading Piston	1	70153-11222
13A.	Viton O-Ring Unloader (1 st)	1	93601-870015
14.	Unloading Spring	1	70153-11231
15.	Unloading Cylinder	1	70153-11211
16.	Unloading Fork	1	70153-31080
17.	Bolt	1	91501-1306016
18.	Cylinder Head Valve Seat Gasket	1	70153-11612
19.	Valve Plate Assembly (Includes 20-28)	1	70153-31001
20.	Valve Seat Bolt	3	91521-1305012
21.	Valve Seat (Upper)	1	70153-31011
22.	Valve Seat Gasket	1	70153-31120
23.	Valve Plate (1 st)	4	70153-31032
24.	Valve Plate Spring (1 st)	4	70153-31072
25.	Valve Plate (2 nd)	2	70153-32032
26.	Valve Plate Spring (2 nd)	2	70153-32072
27.	Valve Seat (Bottom)	1	70153-31021
28.	Nut	2	92501-230500
29.	Cylinder-Valve Seat Gasket	1	70153-11622
30.	Cylinder	1	70153-51011
31.	Cylinder Crankcase Gasket	1	70153-51611
32.	Bolt	6	91501-1310030
33.	Copper Washer	6	92521-191000
34.	Crankcase Oil Cap	1	CCC1257
35.	Oil Cap O-Ring	1	93601-810018
36.	Crankcase	1	70153-57011
37.	Bearing #6026 (Front & Rear)	2	93501-6206
38.	Rear Cover Gasket	1	70153-57961
39.	Rear Cover	1	70153-57061
40.	Rear Cover Bolt	3	91521-1308030
41.	Copper Washer	3	92521-190800
42.	Oil Level Gauge & Gauge Cover	1	70111-57700
43.	Gauge Cover Seal	1	70111-57730
44.	Crankcase Oil Plug (1/4" NPT)	1	70153-12350
45.	Inter-Cooler Bolt	3	91521-1308055
46.	Gasket	1	70153-71611
47.	Inter-Cooler Body	1	70153-71111
48.	Inter-Cooler Body Gasket	1	70153-71622
49.	Inter-Cooler Cover	1	70153-71161
50.	Spring Washer	6	92522-130600
51.	Bolt	6	91501-1306016

	DESCRIPTION	QTY	PART NO.
52.	Compression Ring (1 st)	2	70124-61030
53.	Oil Control Ring (1 st)	2	70124-61050
54.	Piston (1 st)	1	70153-61011
55.	Piston Pin Snap Ring	4	70153-61071
56.	Connection Rod Assembly (1 st)	1	70153-61211
56A.	Connecting Rod Assembly (1 st)***	1	70153-62211
57.	Piston Pin Bush (1 st)	1	70153-61081
58.	Connecting Rod Assembly (2 nd)	1	70153-62211
59.	Piston Pin Bush (2 nd)	1	70153-62081
59A.	Piston Pin Needle Bearing (2 nd)**	1	93503-TA2420
59B.	Piston Pin Needle Bearing (1 st)***	1	93503-TA2420
60.	Connecting Rod Bearing (2 Halves)	2	70153-61090
61.	Crankshaft	1	70153-56011
62.	Piston Pin (1 st)	1	70153-61121
63.	Compression Ring (2 nd)	3	70153-62030
64.	Piston Pin (2 nd)	1	70153-62121
65.	Oil Control Ring (2 nd)	1	70153-62050
66.	Piston (2 nd)	1	70153-62011
67.	Breather Assembly	1	CCC1258
68.	V-Pulley Pin	1	70123-56061
69.	Nut (Connecting Rod)	4	92501-230800
70.	Spring Washer (Connecting Rod)	4	92522-130800
71.	Bolt (Connecting Rod)	4	70153-61250
72.	Front Cover Gasket	1	70153-57951
73.	Front Cover	1	70153-57030
74.	Front Oil Seal	1	70123-57080
75.	Copper Washer	4	92521-190800
76.	Bolt (Front Cover)	4	91501-1310030
77.	Compressor Pulley	1	70153-76011
78.	Compressor Pulley Thrust Washer	1	70123-76210
79.	Compressor Pulley Bolt	1	91501-1310030
80.	Unloading Elbow * #	1	VA786
81.	Unloader Assembly (2 nd)(Includes 82-86)	1	70153-12201
82.	Unloader Cover (2 nd)	1	70103-11271
83.	Viton O-Ring Unloader (2 nd)	1	93601-870009
84.	Unloading Piston (2 nd)	1	70153-12222
85.	Unloading Spring (2 nd)	1	70103-11231
86.	Unloader Body (2 nd)	1	70103-11211
87.	Air Strainer Assembly (Includes 88-93)	1	70153-66002
88.	Air Strainer Cover Gasket	1	70153-66132
89.	Air Strainer Cover	1	70153-66121
90.	Air Strainer Bolt	1	70153-66160
91.	Air Strainer Element	1	70153-66142
92.	Nut (Self Lock) Air Strainer	1	92507-230600
93.	Air Strainer Body	1	70153-66012
94.	Intercooler Safety Valve (Not Shown)	1	VV431
95.	Gasket, Copper	1	70152-12280
96.	HHCS, ¼-20 X ½" LG	2	VH12FD
97.	Lock washer, split ¼"	2	VH35F
98.	Plate, Cover, Flange	1	CA2323
99.	Gasket, Plate Cover	1	CA2312

* Includes Nut(S) And Sleeve(S)

** S/N A4081331 & Later

*** S/N AS07030318 & Later

Not Supplied On Basics

INSPECTION & MAINTENANCE OF E-57 VALVE ASSEMBLY

INSTRUCTION FOR E-57 COMPRESSOR MODEL HEAD VALVE ASSEMBLY INSPECTION AND MAINTENANCE.

Model E-57 valve assembly inspection and maintenance instruction.

1. Inspect valve assemblies every 1000 hours of operation or as necessary to maintain efficient operation.
2. Turn off power, red tag power supply switch (caution: Maintenance in progress – DO NOT START). Drain all air pressure from system before starting work.
3. Disconnect air piping from head.

Remove valve package.

- A1. Loosen and remove head bolts. On constant run models, remove upper tubing from unloader cylinder.
- A2. Remove cylinder head to expose valve assembly.
- A3. Remove valve assembly, head to valve package gasket and valve package to cylinder gasket. Use new gaskets in re-assembly. Note conditions of cylinders, clean out any foreign material and cover with clean shop cloth while open.
- A4. Refer to parts breakdown for description of valve package.
- A5. Secure valve assembly package, loosen and remove socket head bolts to separate the upper and lower valve seats. This will expose the valve springs and valve plates.
CAUTION: Do not interchange upper and lower valve seats
- A6. Thoroughly clean and wash all valve seats and parts with a suitable non-flammable cleaning fluid.
CAUTION: Use care to not scratch or deform valve parts in the cleaning.
- A7. Carefully inspect the valve seats, plates and springs for dents, cracks, wear, and any reason to prevent proper and efficient operation.
- A8. Replace all parts not in proper condition.

Assemble valve assembly package.

- B1. Secure lower valve plate in flat position with spring slots "up".
- B2. Refer to parts breakdown for valve package breakdown.
- B3. Place valve springs and valve plates in proper positions over slots in seat. Use tag wire or string for tie to hold in position for completing assembly.
- B4. Secure upper valve seat in flat position with spring slots up
- B5. Use new valve seat gasket.
- B6. Place valve seat gasket in position on lower valve plate.
- B7. Place upper valve seat with valve springs and plates tied in position on top of lower valve seat with new valve seat gasket in place between the two seats.
- B8. Start center and then two end valve plates socket head bolts, tighten finger tight being careful not to damage seat gasket, use socket head wrench to torque the three bolts uniformly to secure the top valve seat to the lower valve seat using care to avoid damage to the gasket, and valve springs and plates from moving out of position.
- B9. Remove ties to free valve springs and plates
- B10. Check to be sure valve springs and valve plates are in proper position and the plates are free to flex when manually touched with blunt instrument.

Assemble valve assembly package into compressor.

- C1. Use new gaskets, valve package to cylinder and cylinder head to valve package. Select gaskets by part numbers from parts breakdown.
- C2. Remove shop cloth to expose open cylinder bores. Remove any foreign matter from cylinder bores and top of cylinder.
- C3. Place gasket on top of cylinder, place and align valve package, place gasket on top of valve package and align holes for head bolts.
- C4. Place clean head on top of valve package with gasket and align with cylinder bolt holes.
- C5. Insert cylinder head bolts using care to avoid damage to the gaskets, start each bolt threading evenly to contact head surfaces.
- C6. Torque head bolts equally, follow torque specifications on page 20.
- C7. Attach and tighten copper tubing of constant running compressors.
- C8. Assemble and tighten discharge tubing.
- C9. Check oil level in crankcase
- C10. Close and tighten valve or the connections used to drain air pressure from system.
- C11. Remove all tools and make area safe to start compressor.
- C12. Turn on power at main switch and inspect to see that unit is operating properly.
- C13. Stay with unit for normal pump up to cut out pressure.
- C14. If unit has performed through a running cycle properly put on line for duties and remove red tag from power supply switch.
- C15. Make entry in equipment maintenance log.

VALVE PLATES DESIGNS FOR E-57 COMPRESSOR

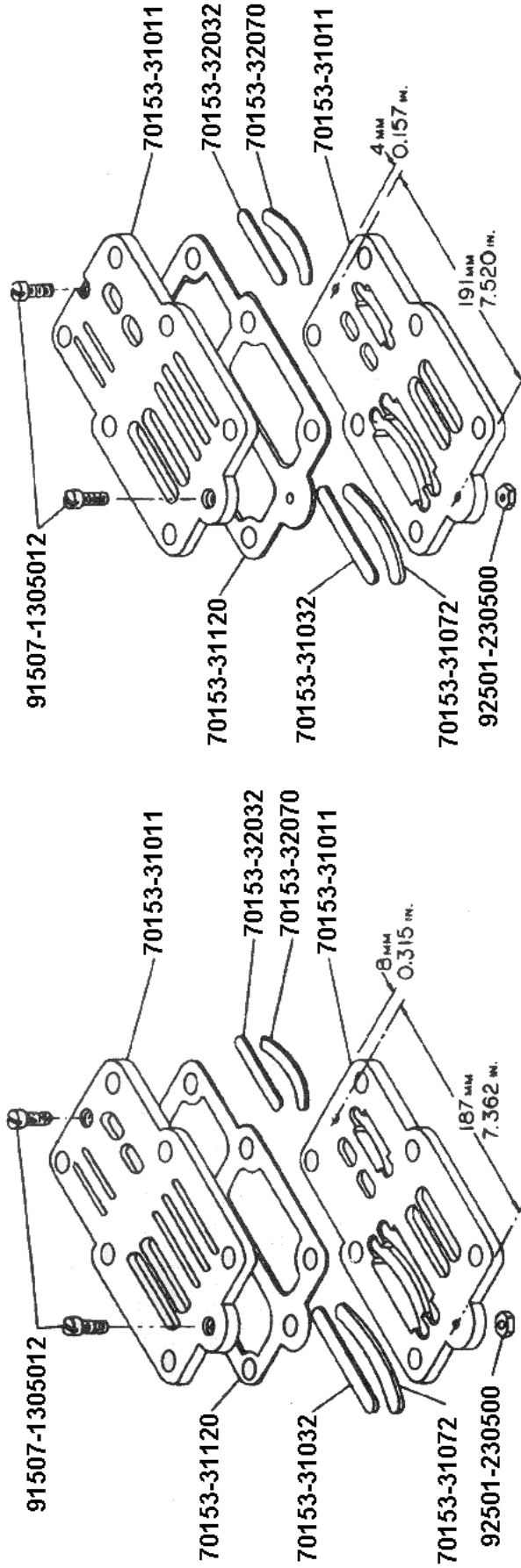

FIG. 1

SERIAL NUMBER 6107030
THROUGH 6116445

FIG. 2

SERIAL NUMBER 7010603
THROUGH 7043734

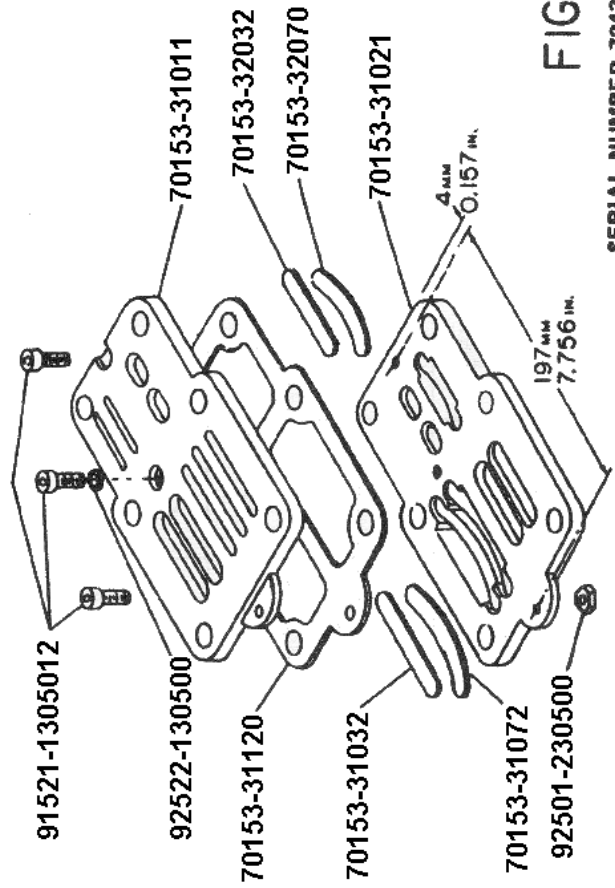

FIG. 4

SERIAL NUMBER 7043735
AND LATER

BOLT TORQUES FOR CHALLENGE AIR COMPRESSORS

	HEAD BOLTS		CYLINDER-CASE		ROD BOLTS		FRONT COVER		REAR COVER		INLET & OUTLET VALVE PUSH COVERS	
	SIZE BOLT	TORQUE CM-FT.	SIZE BOLT	TORQUE CM-FT.	SIZE BOLT	TORQUE CM-FT.	SIZE BOLT	TORQUE CM-FT.	SIZE BOLT	TORQUE CM-FT.	SIZE BOLT	TORQUE CM-FT.
ES03	M6-1	120-8.7			M6-1	135-9.7	M6-1	100-6.8	M6-1	100-6.8		
ES05	M8-1.25	200-14.5	M8-1.25	200-14.5	M8-1.25	180-13.0	M8-1.25	180-13.0	M6-1	100-6.8		
ES06	M6-1	120-8.7	M6-1	120-8.7	M6-1	135-9.7	M6-1	100-6.8	M6-1	100-6.8		
ES10	M8-1.25	200-14.5	M8-14.5	200-14.5	M8-1.25	180-13.0	M8-1.25	180-13.0	M8-1.25	180-13.0		
E11	M8-1.25	200-14.5	M8-1.25	200-14.5	M8-1.25	180-13.0	M8-1.25	180-13.0	M8-1.25	180-13.0		
ES20	M8-1.25	200-14.5	M8-1.25	200-14.5	M8-1.25	180-13.0	M8-1.25	180-13.0	M8-1.25	180-18.0		
E23	M8-1.25	200-14.5	M8-1.25	200-14.5	M8-1.25	180-13.0	M8-1.25	180-13.0	M8-1.25	180-13.0		
ES30	M10-1.5	300-21.7	M10-1.5	280-20.25	M10-1.5	280-20.25	M10-1.5	280-20.25	M10-1.5	280-20.25	M8-1.25	225-16.3
E35	M8-1.25	200-14.5	M8-1.25	200-14.5	M8-1.25	180-13	M8-1.25	180-13	M8-1.25	300-21.7		
ES50	M10-1.5	300-21.7	M10-1.5	280-20.25	M8-1.5	280-20.25	M8-1.5	280-20.25	M10-1.5	280-20.25	M8-1.25	225-16.3
E50	M10-1.5	300-21.7	M10-1.5	280-20.25	M8-1.5	280-20.25	M8-1.5	280-20.25	M10-1.5	280-20.25	M8-1.25	225-16.3
E57	M10-1.5	320-23.1	M10-1.5	280-20.25	M8-1.25	280-20.25	M10-1.5	300-21.7	M8-1.25	300-21.7		
ES100	M10-1.5	320-23.1	M10-1.5	280-20.25	M8-1.5	300-21.7	M8-1.5	300-21.7	M10-1.5	280-20.25	M8-1.25	225-16.3
E71	M10-1.5	320-23.1	M10-1.5	280-20.25	M8-1.5	300-21.7	M8-1.5	300-21.7	M10-1.5	280-20.25	M8-1.25	225-16.3
ES150	M10-1.5	320-23.1	M10-1.75	350-25.3	M10-1.5	320-23.1	M10-1.5	320-23.11	M10-1.5	28-120.25	M10-1.5	320-23.1
E15	M10-1.5	320-23.1	M10-1.75	350-25.3	M10-1.5	320-23.1	M10-1.5	320-23.1	M10-1.5	280-20.25	L M10-1.5 H M8-1.25	320-23.1 225-16.3

BOLT TORQUES

MODEL NO.	FLYWHEEL BOLTS		FAN BOLTS	
	TORQUE FT.-LBS.	TORQUE IN.-LBS.	TORQUE FT.-LBS.	TORQUE IN.-LBS.
ES03	8	96	-	-
ES05 ES06 ES10 E11 ES20 E23 E35	12	144	-	-
E57	23	276	-	-
ES30	30	360	-	-
ES50 E50	40	480	-	-
E71 ES100	45	540	24	288
E15 ES150	50	600	24	288

OIL CAPACITIES

MODEL NUMBER	HORSEPOWER	MIN RPM	OIL CAPACITY
ES03	1/4 – 1/2	500	1/2 PINTS
ES05	1/2	500	1/2 PINTS
ES06	3/4	500	10 OUNCES
ES10	1	500	1¼ PINTS
ES20	2 – 3	500	1¾ PINTS
ES30	3 – 5	500	1¼ PINTS
ES50	5 – 7½	500	1½ QUARTS
ES100	7½ - 10	500	2½ QUARTS
ES150 ES150A	15	500	5 QUARTS
E11	1	500	1¼ PINTS
E23	2 – 3	500	1¾ PINTS
E35	3 – 5	500	2½ PINTS
E50	5	500	1½ QUARTS
E57	5 – 7½	500	2 QUARTS
E71	10	500	2½ QUARTS
E15	15	500	5 QUARTS

TROUBLESHOOTING

	SYMPTOMS	CAUSES	REMEDIES
WHEN COMPRESSOR CAN BE STARTED	Flywheel rotation in wrong direction	Incorrect connection of motor terminal	Re-arrange terminal connection.
	Overheating of bearings	1. Insufficient lubrication. 2. Bad lubrication system. 3. Crankshaft bearings too tight.	1. Add lubrication oil. 2. Remove and examine the system. 3. Readjust load on bearings.
	Flywheel rotation slows down	1. Heavy lubrication oil. 2. Drop in voltage. 3. Belts slipping.	1. Refill with lighter lubrication oil. 2. Contact power company or install a transformer. 3. Tighten belts
	Severe vibration	Bent crankshaft	Remove & Replace
	Abnormal noise	1. Loose valve assembly. 2. Piston hits cylinder cover. 3. Worn connecting rod bearing.	1. Tighten valve bolt and lock nut. 2. Check piston & rod assembly for excessive wear. 3. Replace bearing.
	Pressure cannot be built up or only up to a certain extent	1. Worn valve plate. 2. Valve springs have lost their temper. 3. Dirt on the valve plate. 4. Leaks from safety valve. 5. Leaks from bolt holes. 6. Uneven valve seat surface. 7. Excessive blow by on piston rings. 8. Bad packing (gasket too thick). 9. Excessive air leaks.	1. Repair or replace valve plate. 2. Replace valve springs. 3. Remove and clean it. 4. Repair or replace safety valve. 5. Tighten the nuts even with packing. 6. Remove and lap the surface. 7. Replace with new ones 8. Replace packing (gasket). 9. Eliminate air leaks.
	Inaccuracy of pressure gauge	Pressure gauge damaged.	Replace.
	Excessive oil consumption	1. Worn piston ring 2. Worn piston. 3. Worn cylinder.	1. Replace. 2. Replace. 3. Replace.
	Slipping of belts	1. Working pressure too high. 2. Improper belt tension. 3. Worn belt.	1. Lower working pressure. 2. Adjust belt tension. 3. Replace with new ones.
	Overheating of electric motors	1. Overloading of motor due to excessive working pressure (higher than stipulated pressure). 2. Burnt piston. 3. Burnt bearing metals. 4. Drop of voltage.	1. Lower working pressure. 2. Rebuild compressor. 3. Rebuild compressor. 4. Contact power company or install a transformer
WHEN COMPRESSOR CANNOT BE STARTED	Unit will not start	1. Breakdown of electric current. 2. Line failure. 3. Malfunction of motor	1. Contact power company. 2. Examine the line. Replace with new wiring. 3. Contact motor manufacturer.
	Fuse tends to blow	1. Incorrect size. 2. Wrong connections 3. Overloading of motor. 4. Overloading of motor due to leaks of outlet valve. 5. Crankshaft too tight.	1. Replace with correct size. 2. Change connections. 3. Eliminate the loading. 4. Remove and repair outlet valve. 5. Remove crankshaft and examine it for cause.

CURTIS-TOLEDO

CUSTOMER SERVICE (314) 383-1300

RECOMMENDED STATEMENT ON DRYERS AND FILTERS

Liquid water occurs naturally in air lines as a result of compression. Moisture vapor in ambient air is concentrated when pressurized and condenses when cooled in downstream air piping.

Compressed air dryers reduce water vapor concentration and prevent liquid water formation in compressed air lines. Dryers are necessary companion to air filters, aftercoolers, and automatic tank drains for improving the productivity of compressed air systems.

Water and water vapor removal increases the efficiency of air operated equipment, reduces contamination and rusting, increases service life of pneumatic equipment and tools, prevents air line freeze ups, and reduces product rejects. The use of dryer's filters is recommended when this moisture related problems are reported to our factory or distributor service departments.

Troubleshooting guide

Symptom: Liquid water present in compressed air lines.

Problem: Water vapor condensation from cooling and compression occurs naturally

Solution: Remove the water vapor from compressed air prior to distribution through the air system. Check operation of after-cooler and moisture separator. Install a compressed air dryer sized for the flow and dryness level required.

(Note: filters may also be required to remove particles, liquid oil aerosols, or for oil vapor removal. Change cartridges as recommended by filter manufacturer.)

Check all drain traps routinely to insure their proper operation. Maintain them regularly.

COMPRESSOR PUMP-UP TIME

TWO STAGE

H.P. Size	Compressor Model No.	R.P.M.	Piston Displ. C.F.M.	Tank size		Approx. Time Required To Pump From:	
				Size (in)	Gal	0 to 175 PSIG Min. – Sec.	145 to 175 PSIG Min. – Sec.
3	3VT6	947	10.66	20 x 50	60	12' – 24"	2' – 8"
5	5E23VT6	1000	11.3	20 x 50	60	11' – 47"	2' – 1"
5	5E1HT6	1100	15.81	20 x 50	60	7' – 46"	1' – 20"
5	5E1VT6	1100	15.81	20 x 50	60	7' – 46"	1' – 20"
5	5E1HT8	1100	15.81	20 x 48	80	10' – 21"	1' – 46"
5	5E1VT8	1100	15.81	20 x 48	80	10' – 21"	1' – 46"
5	5HT6	968	20.58	20 x 50	60	5' – 56"	1' – 1"
5	5VT6	968	20.58	20 x 50	60	5' – 56"	1' – 1"
5	5HT8	968	20.58	20 x 66	80	7' – 54"	1' – 21"
5	5VT8	968	20.58	20 x 48	80	7' – 54"	1' – 21"
5	5E2HT6	900	21.47	20 x 50	60	5' – 25"	0' – 56"
5	5E2VT6	900	21.47	20 x 50	60	5' – 25"	0' – 56"
5	5E2HT8	900	21.47	20 x 66	80	7' – 14"	1' – 14"
5	5E2VT8	900	21.47	20 x 48	80	7' – 14"	1' – 14"
7 1/2	7E2HT8	1100	26.24	20 x 66	80	6' – 16"	1' – 05"
7 1/2	7E2VT8	1100	26.24	24 x 48	80	6' – 16"	1' – 05"
7 1/2	7HT8	764	29.57	20 x 66	80	5' – 22"	0' – 55"
10	10HT8	977	37.81	20 x 66	80	4' – 11"	0' – 43"
10	10HT12	977	37.81	24 x 70	120	6' – 17"	1' – 5"
10	10VT12	977	37.81	30 x 47	120	6' – 17"	1' – 5"
15	15HT12	855	54.55	24 x 70	120	4' – 28"	0' – 46"

TWO STAGE GASOLINE ENGINE DRIVEN

H.P. Size	Compressor Model No.	R.P.M.	Piston Displ. C.F.M.	Tank size		Approx. Time Required To Pump From:	
				Size (in)	Gal	0 to 175 PSIG Min. – Sec.	145 to 175 PSIG Min. – Sec.
10	10E2GT3	910	21.7	16 x 41	30	2' – 42"	0' – 28"
10	10GT3	950	20.2	16 x 41	30	3' – 1"	0' – 31"
10	10GT6	950	20.2	20 x 50	60	6' – 3"	1' – 2"
13	13E2GT3K	910	21.7	16 x 41	30	2' – 42"	0' – 28"
13	13GT3K	950	20.2	16 x 41	30	3' – 1"	0' – 31"
13	13GTGK	950	20.2	20 x 50	60	6' – 3"	1' – 2"
13	13E2GT3HE	910	21.7	16 x 41	30	2' – 42"	0' – 28"

COMPRESSOR PUMP-UP TIME

SINGLE STAGE

H.P. Size	Compressor Model No.	R.P.M.	Piston Displ. C.F.M.	Tank size		Approx. Time Required To Pump From:	
				Size (in)	Gal	0 to 100 PSIG Min. – Sec.	80 to 100 PSIG Min. – Sec.
3	3HS6	945	15.97	20 x 50	60	6' – 16"	1' – 15"
3	3VS6	945	15.97	20 x 50	60	6' – 16"	1' – 15"
5	5ES20VS6	1000	16.9	20 x 50	60	6' – 4"	1' – 13"
5	5HS6	945	20.13	20 x 50	60	4' – 8"	0' – 50"
5	5VS6	945	20.13	20 x 50	60	4' – 8"	0' – 50"
5	5HS6	945	20.13	20 x 66	80	5' – 31"	1' – 6"
5	5VS8	945	20.13	24 x 48	80	5' – 31"	1' – 6"
7 1/2	7HS8	945	30.14	20 x 66	80	3' – 35"	0' – 43"
7 1/2	7VS8	945	30.14	24 x 48	80	3' – 35"	0' – 43"
10	10HS8	866	50.4	20 x 66	80	2' – 7"	0' – 25"
10	10HS12	866	50.4	24 x 70	120	3' – 10"	0' – 38"
10	10VS12	866	50.4	30 x 47	120	3' – 10"	0' – 38"
15	15HS12	855	81.74	24 x 70	120	2' – 2"	0' – 24"

NOTES

CURTIS – TOLEDO, INC.

1905 KIENLEN AVE., ST. LOUIS, MO 63133
TEL. (314) 383-1300 FAX (314) 381-1439
E-MAIL: info@curtistoledo.com
www.curtistoledo.com