



SPARE PARTS LIST

TROWELS

CT36-5A, 2020-02

Go to Discount-Equipment.com to order your parts



PARTS FINDER

**Search Website
by Part Number**



**Search Manual
Library For Parts
Manual & Lookup Part
Numbers – Purchase
or Request Quote**

Search Manuals

Enter your information to help us find the right parts manual for your machine.

* Brand:

* Model:

* Serial:

* Part Number:

SEARCH

**Can't Find Part or
Manual? Request Help
by Manufacturer,
Model & Description**

Parts Order Form

Please fill in the following information to help us find the right part for your machine.

Manufacturer:	<input type="text"/>
Model:	<input type="text"/>
Description:	<input type="text"/>
Part Number:	<input type="text"/>
Quantity:	<input type="text"/>
Notes:	<input type="text"/>

Submit

Discount-Equipment.com is your online resource for quality parts & equipment.

Florida: **561-964-4949** Outside Florida TOLL FREE: **877-690-3101**

Need parts?

Click on this link: <http://www.discount-equipment.com/category/5443-parts/> and choose one of the options to help get the right parts and equipment you are looking for. Please have the machine model and serial number available in order to help us get you the correct parts. If you don't find the part on the website or on one of the online manuals, please fill out the request form and one of our experienced staff members will get back to you with a quote for the right part that your machine needs.

We sell worldwide for the brands: Genie, Terex, JLG, MultiQuip, Mikasa, Essick, Whiteman, Mayco, Toro Stone, Diamond Products, Generac Magnum, Airman, Haulotte, Barreto, Power Blanket, Nifty Lift, Atlas Copco, Chicago Pneumatic, Allmand, Miller Curber, Skyjack, Lull, Skytrak, Tsurumi, Husquvarna Target, Stow, Wacker, Sakai, Mi-T-M, Sullair, Basic, Dynapac, MBW, Weber, Bartell, Bennar Newman, Haulotte, Ditch Runner, Menegotti, Morrison, Contec, Buddy, Crown, Edco, Wyco, Bomag, Laymor, EZ Trench, Bil-Jax, F.S. Curtis, Gehl Pavers, Heli, Honda, ICS/PowerGrit, IHI, Partner, Imer, Clipper, MMD, Koshin, Rice, CH&E, General Equipment, Amida, Coleman, NAC, Gradall, Square Shooter, Kent, Stanley, Tamco, Toku, Hatz, Kohler, Robin, Wisconsin, Northrock, Oztec, Toker TK, Rol-Air, APT, Wylie, Ingersoll Rand / Doosan, Innovatech, Con X, Ammann, Mecalac, Makinex, Smith Surface Prep, Small Line, Wanco, Yanmar

A CT36-5A
HANDLE, LOWER

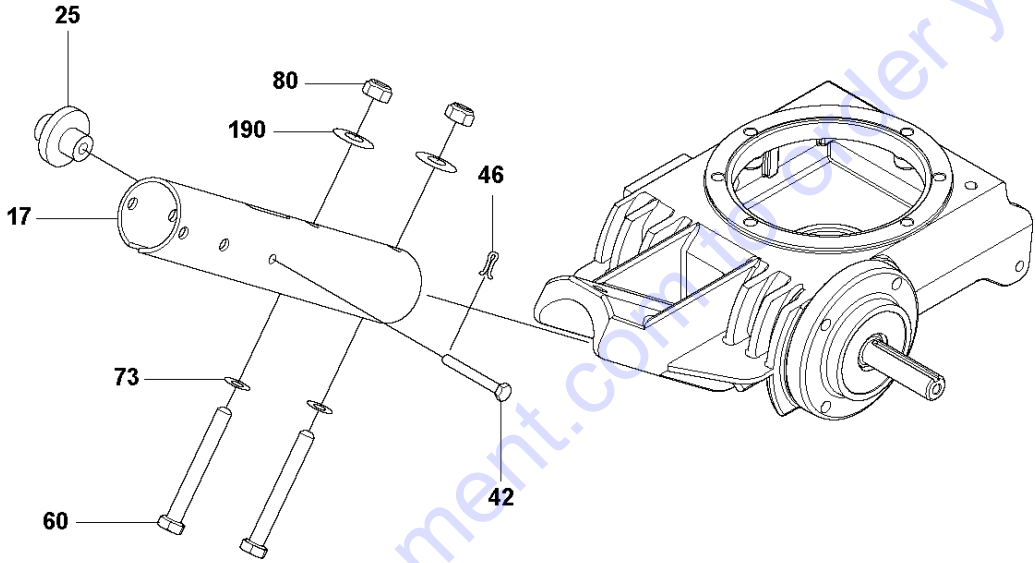

Ref	Part No	Description	Remark	QTY KIT
17	599 00 24-01	PIPE		1
25	599 17 15-01	PULLEY		1
42	599 16 80-01	PIN	CLEVIS PIN 1/4x2-3/8in	1
46	599 16 43-01	PIN	COTTER PIN 1,6x16, DIN 94	1
60	599 16 04-01	SCREW	M10x85, ISO4014, 49Nm/36ft.lbs	2
73	734 11 72-01	WASHER	M10, 200HV, A2K, DIN125B	2
80	732 21 20-51	NUT	M10, DIN985	2
190	599 15 99-01	WASHER	M10, A2K, ISO 7093	2

Go to Discount-Equipment.com to order your parts

DRIVE

CT36-5A, 2020-02

Ref	Part No	Description	Remark	QTY KIT
1	599 08 36-01	RING	48	1
2	599 41 85-01	ENGINE	5.5hp	1
3	599 13 15-02	BELT GUARD		1
4	599 00 82-01	PLATE		1
23	598 98 71-01	CLUTCH		1
24	599 00 54-01	PULLEY		1
26	598 98 99-01	BELT		1
36	599 00 76-01	SPACER		2
37	599 04 08-01	SWITCH		1
49	599 17 76-01	STUD		4
50	599 16 62-01	SCREW	5/16-24 x 3/4in25Nm/18ft.lbs	4
51	599 17 07-01	SCREW	5/16-24 x 2in25Nm/18ft.lbs	1
52	725 22 95-71	SCREW EHHM	M4 x 203Nm/2ft.lbs	2
53	596 32 01-01	BOLT	M6 x 105Nm/4ft.lbs, DIN933	3
54	725 24 55-51	SCREW	25Nm/18ft.lbs	1
55	725 24 53-71	SCREW EHHM	SCREW EHHM ISO 4017 M 8 X 25 8.8 ZPB	1
56	599 16 20-01	SCREW	M8 x 3030Nm/22ft.lbs, ISO10642	4
68	599 16 19-01	LOCKWASHER	8	4
69	734 11 54-41	WASHER	6	3
70	599 17 64-01	WASHER		1
72	599 16 29-01	WASHER		1
73	734 11 72-01	WASHER		1
76	734 11 46-01	WASHER		2
77	599 00 14-01	CLAMP		1
78	599 15 98-01	LOCK NUT		2
79	522 91 94-01	LOCK NUT	M825Nm/18ft.lbs, DIN985	4
82	599 17 00-01	KEY		1
84	599 17 06-01	KEY	3/16 x 2-7/8in	1
125	599 02 75-01	WIRING		1

Go to Discount-Equipment.com to order your parts

C CT36-5A
BLADE ASSY

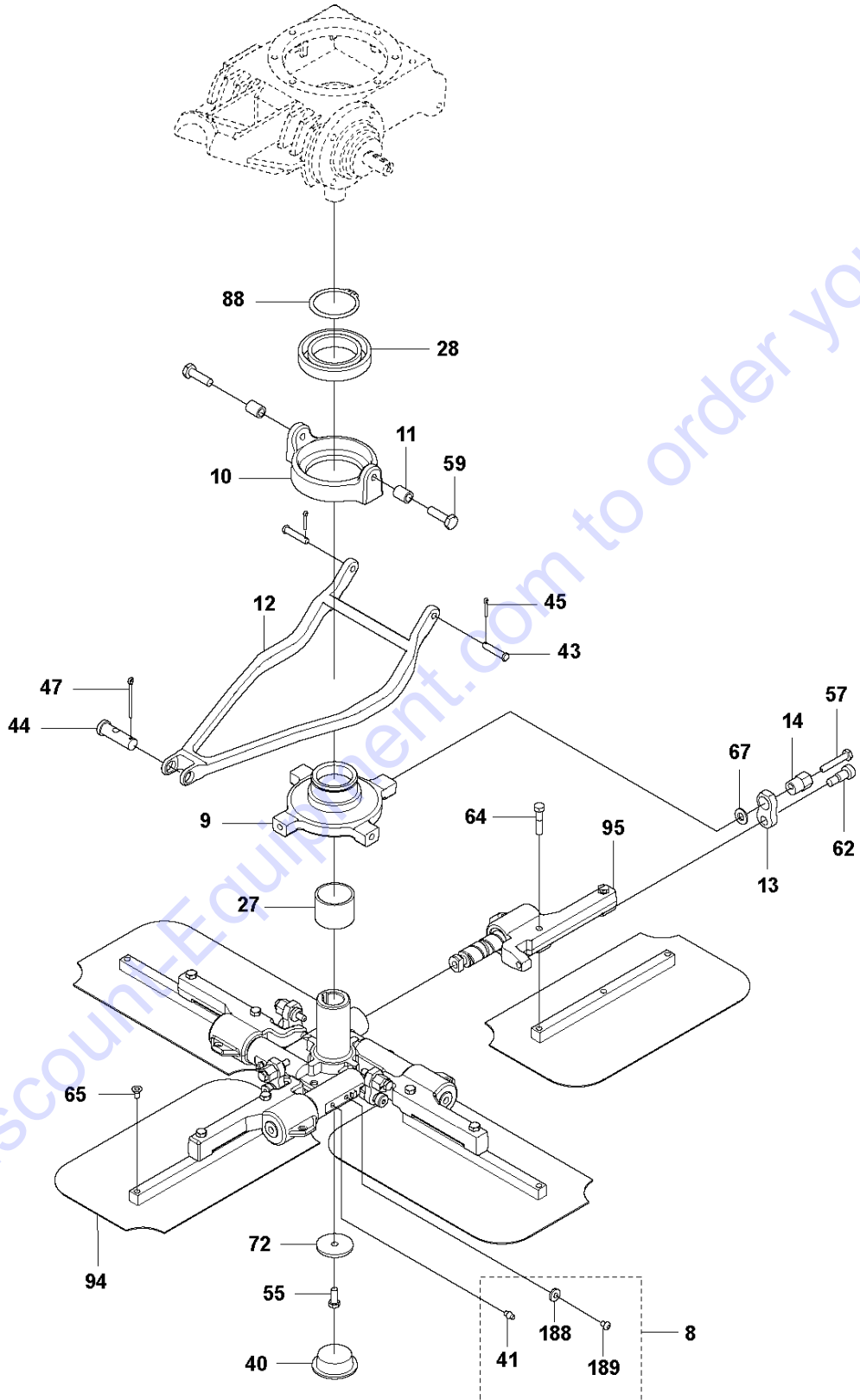

Go to DiscountEquipment.com to order your parts

BLADE ASSY

CT36-5A, 2020-02

Ref	Part No	Description	Remark	QTY	KIT
8	599 41 81-01	KIT		1	
9	599 04 07-01	RING		1	
10	598 99 63-01	HOLDER		1	
11	599 04 81-01	TUBE		2	
12	599 00 07-01	YOKE		1	
13	599 01 14-01	LINK		4	
14	599 01 09-01	EXCENTER		4	
27	598 98 72-01	BEARING	46MM ID	1	
28	598 99 67-01	BEARING	6012-2NSE	1	
40	598 98 73-01	PLUG	#W20,TAPER,PLAST. RED	1	
41	599 17 66-01	FITTING	AM6, DIN71412	4	8
43	599 16 31-01	PIN	5/16x1 - 1/2"	2	
44	599 16 86-01	PIN		1	
45	599 16 14-01	PIN	1/8 x 3/4in	2	
47	599 16 36-01	PIN	1/8 x 1-1/4in	1	
55	725 24 53-71	SCREW EHHM	M8x25, ISO4017, 25Nm/18ft.lbs	1	
57	599 16 59-01	SCREW	M8x45, 41Nm/30ft.lbs	4	
59	599 17 34-01	SCREW	M10x25, 12.9	2	
62	599 16 97-01	SCREW	M10x12x16, 25Nm/18ft.lbs	4	
64	599 16 71-01	SCREW	5/16-18 x 1-5/8"	8	
65	599 16 34-01	PLUG	#1,TAPERED,PLASTC,RE D	4	
67	734 11 65-41	WASHER	8.4x24x2, ISO7093, ZPB	4	
72	599 16 29-01	WASHER		1	
88	599 16 23-01	RETAINER RING	60x2, DIN471	1	
94	598 92 95-02	BLADE SET	36"	1	
95	599 41 43-01	MOUNT		4	
188	576 82 31-01	WASHER	M6,4	4	8
189	599 17 42-01	SCREW	M6x8, 10.9	4	8

Go to Discount-Equipment.com to enter your parts

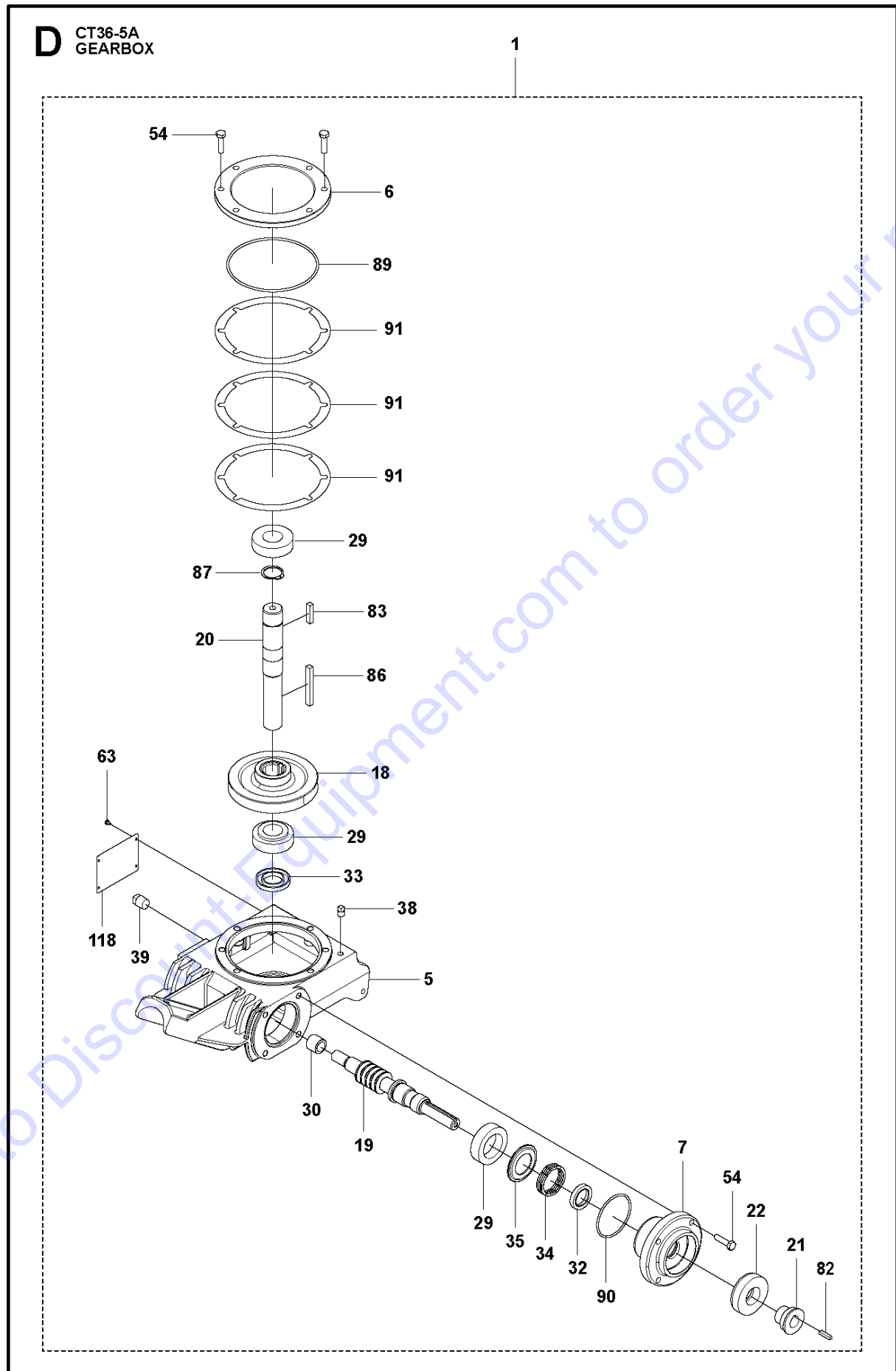

GEARBOX

CT36-5A, 2020-02

Ref	Part No	Description	Remark	QTY	KIT
1	599 41 82-01	GEARBOX		1	
5	599 01 83-01	GEARBOX		1	1
6	598 99 84-01	COVER		1	1
7	599 00 80-01	COVER		1	1
18	599 00 16-01	GEAR		1	1
19	599 01 84-01	SHAFT		1	1
20	599 05 22-01	SHAFT		1	1
21	599 02 53-01	BRAKE		1	1
22	599 02 54-01	BRAKE		1	1
29	599 00 32-01	BEARING		3	1
30	599 01 85-01	BEARING		1	1
32	599 01 04-01	SEAL	28x40x7 VTF	1	1
33	599 01 05-01	SEAL	30x52x7 VTF	1	1
34	599 01 03-01	SPRING		1	1
35	599 00 31-01	SPACER		1	1
38	599 41 67-01	VALVE		1	1
39	599 41 71-01	PLUG	3/8 NPTF	1	1
54	725 24 55-51	SCREW	M8x30, ISO4017, 8.8, ZPB, 25Nm/18ft.lbs	6	1
63	599 17 67-01	SCREW	3-48x5/32	4	1
82	599 17 00-01	KEY		1	1
83	599 17 01-01	KEY		1	1
86	599 16 69-01	KEY	8x7x70	1	1
87	599 17 65-01	RETAINER RING	30x1,5, DIN471	1	1
89	599 00 94-01	O-RING	3,5x138	1	1
90	599 01 86-01	O-RING	3x67	1	1
91	599 41 86-01	SHIM		1	1
118	599 01 75-01	LABEL		1	1

Go to Discount-Equipment.com to order your parts

E CT36-5A
HANDLE WITH TWIST PITCH

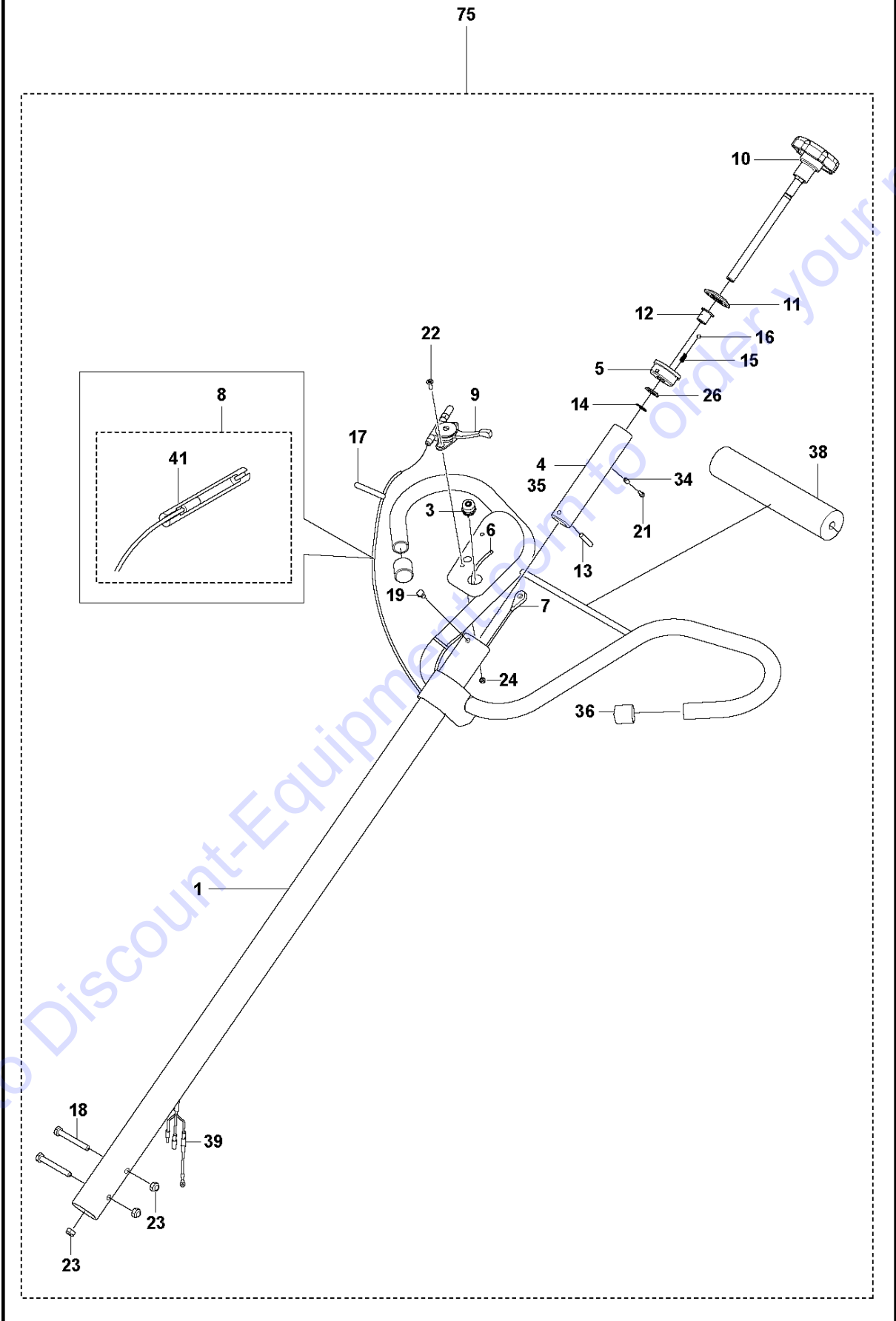

Ref	Part No	Description	Remark	QTY	KIT
1	599 08 66-01	HANDLE		1	75
3	599 08 70-01	SWITCH		1	75
4	599 03 79-01	NUT		1	75
5	599 00 28-01	HOLDER		1	75
6	599 08 69-01	HARNESS		1	75
7	599 00 26-01	CABLE		1	75
8	599 01 02-01	CABLE		1	75
9	599 01 08-01	LEVER		1	75
10	599 12 50-01	KNOB		1	75
11	599 01 07-01	PLATE		1	75
12	599 00 29-01	BEARING		1	75
13	599 17 22-01	PIN	1/4 x 1-3/8"	1	75
14	599 16 88-01	RETAINER RING	9	1	75
15	599 00 41-01	SPRING		1	75
16	599 16 96-01	BALL		1	75
17	599 16 22-01	CABLE		3	75
18	725 24 64-51	SCREW EHHM	M8x65, ISO4014, Zn, 25Nm/18ft.lbs	2	75
19	725 23 64-71	SCREW EHHM	M6x10, ISO4017, 8.8, ZPB, 5Nm/4ft.lbs	1	75
21	599 16 05-01	SCREW	M4x10, ISO4762, 8.8, Zn, 5Nm/4ft.lbs	1	75
22	599 17 72-01	SCREW	M5x16, 8.8, Zn	2	75
23	522 91 94-01	LOCK NUT	M8, ISO7040, 6H, A2	3	75
24	732 21 14-01	LOCK NUT	M5, ISO7040, 6H, A2	2	75
26	734 11 78-01	WASHER	13?24?2.5, ISO7089, 200HV, ZPB	1	75
34	599 03 93-01	SPACER	1/4x0.17x3/8"	1	75
35	599 17 21-01	SLEEVE	3/4x2.0 x9.0"	1	75
36	599 04 05-01	CAP		2	75
38	599 03 85-01	PAD		1	75
39	599 02 75-01	WIRING		1	75
41	599 41 90-01	THROTTLE		1	75, 8
75	598 92 68-02	HANDLE	Complete	1	

Go to Discount-Equipment.com to order your parts

F CT36-5A
HANDLE, ADJUSTABLE WITH TWIST PITCH

75

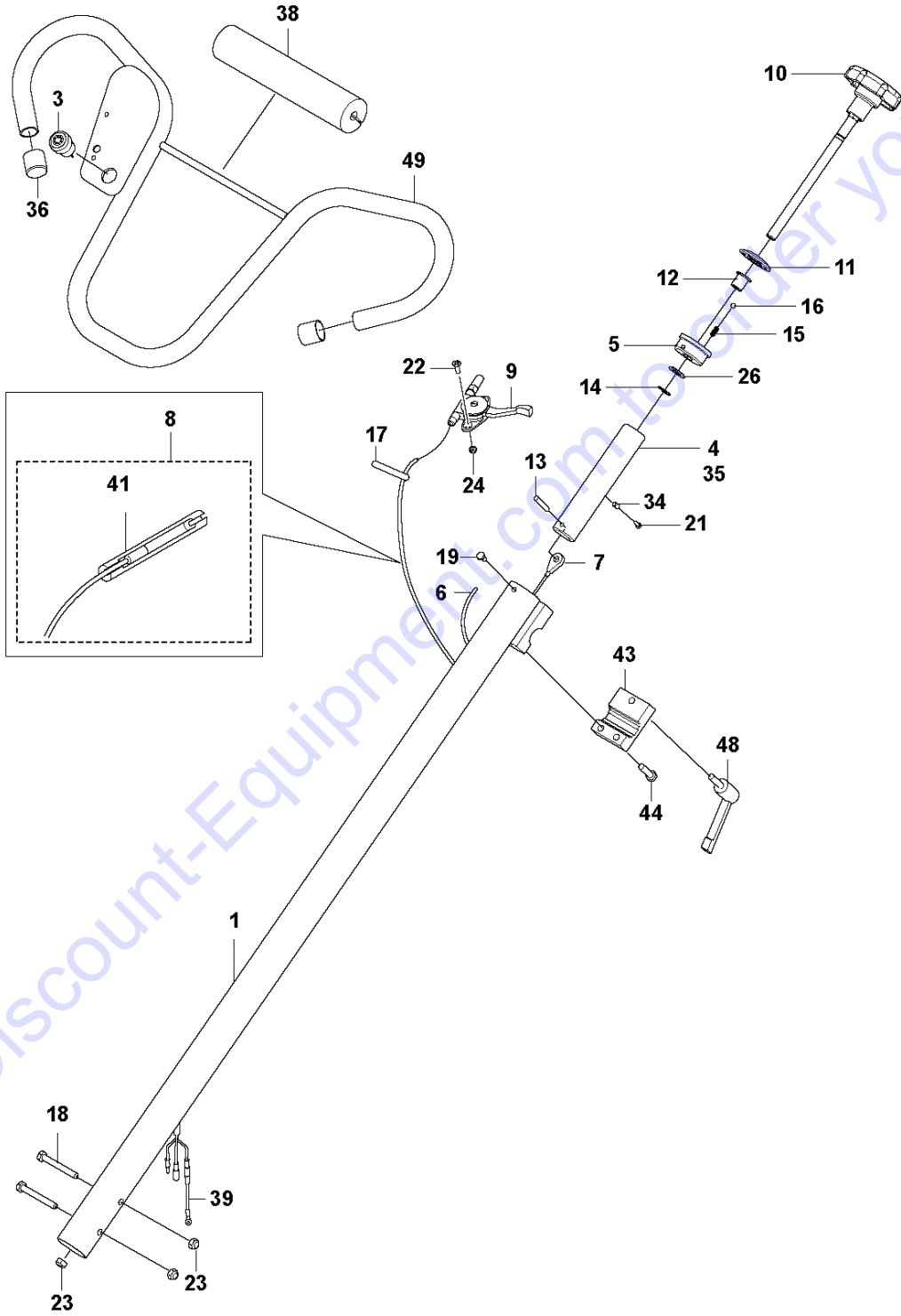

Ref	Part No	Description	Remark	QTY	KIT
1	599 02 65-01	HANDLE		1	75
3	599 08 70-01	SWITCH		1	75
4	599 03 79-01	NUT		1	75
5	599 00 28-01	HOLDER		1	75
6	599 08 69-01	HARNESS		1	75
7	599 00 26-01	CABLE		1	75
8	599 01 02-01	CABLE		1	75
9	599 01 08-01	LEVER		1	75
10	599 12 50-01	KNOB		1	75
11	599 01 07-01	PLATE		1	75
12	599 00 29-01	BEARING		1	75
13	599 17 22-01	PIN	1/4 x 1-3/8"	1	75
14	599 16 88-01	RETAINER RING	9	1	75
15	599 00 41-01	SPRING		1	75
16	599 16 96-01	BALL		1	75
17	599 16 22-01	CABLE		2	
18	725 24 64-51	SCREW EHHM	M8x65, ISO4014, Zn, 25Nm/18ft.lbs	2	75
19	725 23 64-71	SCREW EHHM	M6x10, ISO4017, 8.8, ZPB, 5Nm/4ft.lbs	1	75
21	599 16 05-01	SCREW	M4x16, 5Nm/4ft.lbs	1	75
22	599 17 72-01	SCREW	M5x16	2	75
23	522 91 94-01	LOCK NUT	M8, ISO7040, 6H, A2	3	75
24	732 21 14-01	LOCK NUT	M5, ISO7040, 6H, A2	2	75
26	734 11 78-01	WASHER	M12, 13x24x2.5, ISO7090, 200HV, ZPB	1	75
34	599 03 93-01	SPACER	1/4 x 0.17 x 3/8	1	75
35	599 17 21-01	SLEEVE	3/4x2.0x9.0in	1	75
36	599 04 05-01	CAP		2	75
38	599 03 85-01	PAD		1	75
39	599 02 75-01	WIRING		1	75
41	598 98 62-01	CHEMICAL	25Nm/18ft.lbs	1	75, 8
43	599 01 89-01	BLOCK		1	75
44	725 24 55-51	SCREW	M8x30, ISO4017, 8.8, ZPB, 25Nm/18ft.lbs	2	75
48	599 03 07-01	HANDLE		1	75
49	599 08 65-01	HANDLE		1	75
75	598 92 68-08	HANDLE	Complete	1	

Go to Discount-Equipment.com to order your parts

G CT36-5A
HANDLE, ADJUSTABLE WITH PRO-SHIFT®

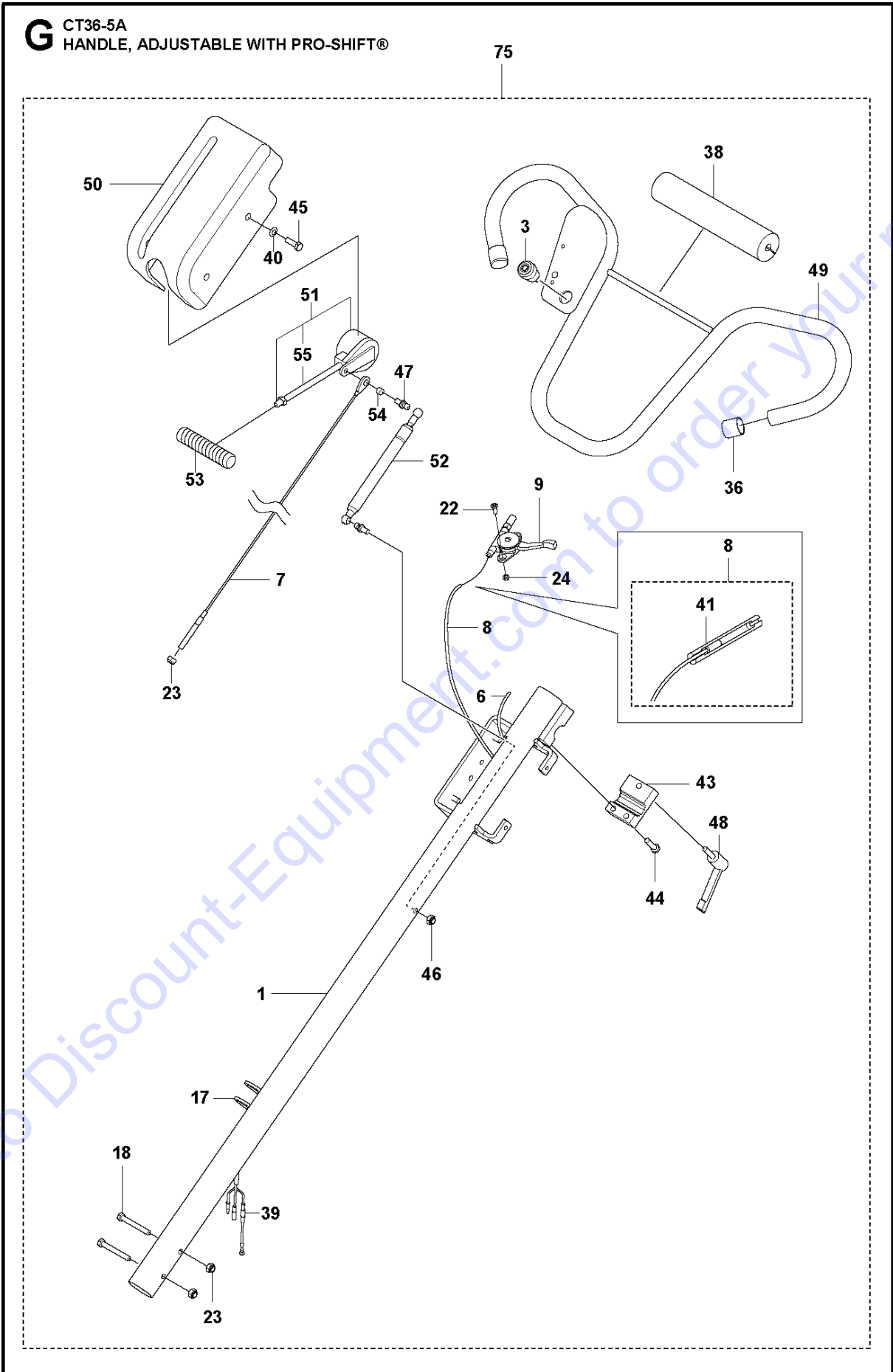

Ref	Part No	Description	Remark	QTY	KIT
1	599 02 30-01	HANDLE		1	75
3	599 08 70-01	SWITCH		1	75
6	599 08 69-01	HARNESS		1	75
7	599 00 26-01	CABLE		1	75
8	599 01 02-01	CABLE		1	75
9	599 01 08-01	LEVER		1	75
17	599 16 22-01	CABLE		2	75
18	725 24 64-51	SCREW EHHM	M8x65, ISO4014, Zn, 25Nm/18ft.lbs	2	75
22	599 17 72-01	SCREW	M5 x 16	2	75
23	522 91 94-01	LOCK NUT	M8, ISO7040, 6H, A2	3	75
24	732 21 14-01	LOCK NUT		2	75
36	599 04 05-01	CAP		2	75
38	599 03 85-01	PAD		1	75
39	599 02 75-01	WIRING		1	75
40	734 11 63-01	WASHER		4	75
41	598 98 62-01	CHEMICAL	25Nm/18ft.lbs	1	75
43	599 01 89-01	BLOCK		1	75
44	725 24 55-51	SCREW	M8x30, ISO4017, 8.8, ZPB, 25Nm/18ft.lbs	2	75
45	725 24 53-71	SCREW EHHM	M8x25, ISO4017, 8.8, ZPB, 25Nm/18ft.lbs	4	75
46	576 64 57-04	NUT FLANGE	M8, 16Nm/12ft.lbs	1	75
47	599 16 87-01	STUD	M8x10, 16Nm/12ft.lbs	2	75
48	599 03 07-01	HANDLE		1	75
49	599 08 65-01	HANDLE		1	75
50	599 20 90-01	COVER		1	75
51	599 20 88-01	CONTROL		1	75
52	599 01 64-01	SPRING	90 lb	1	75
53	599 20 91-01	HANDLE		1	75
54	599 20 89-01	SPACER		1	75
55	599 41 42-01	ROD		1	75
75	598 92 68-12	HANDLE	Complete	1	75

Go to Discount-Equipment.com to order your parts

H CT36-5A
LIFT BRACKET KIT, LONG

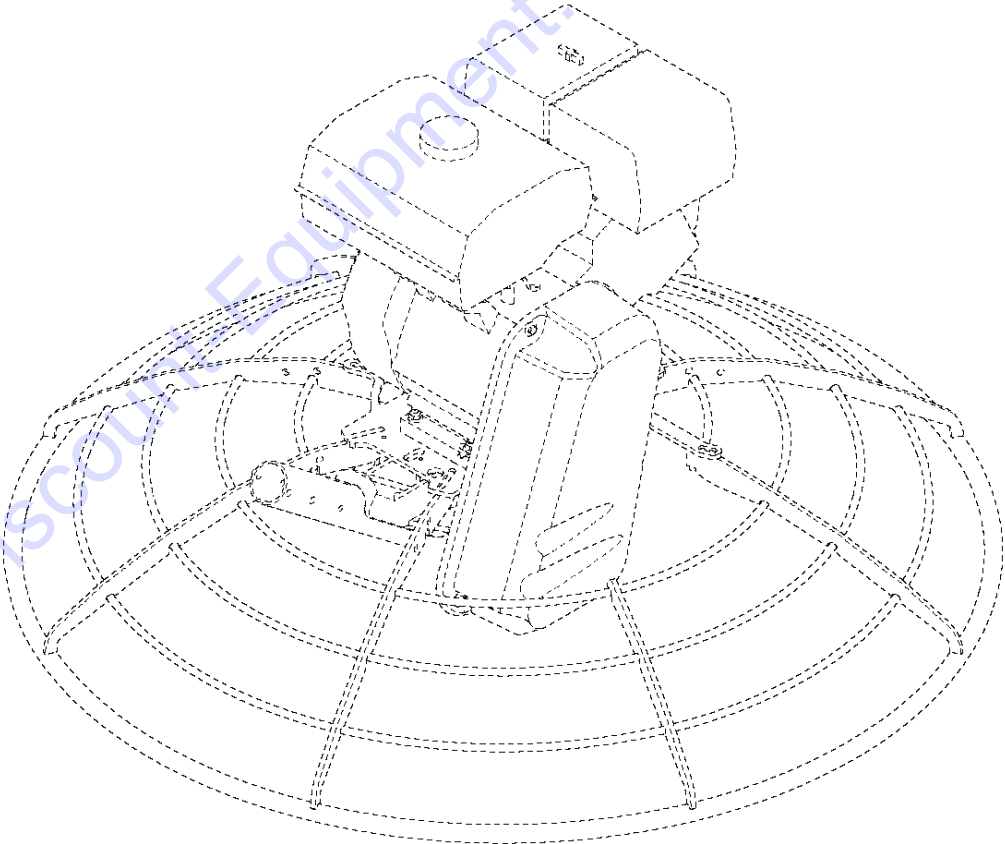
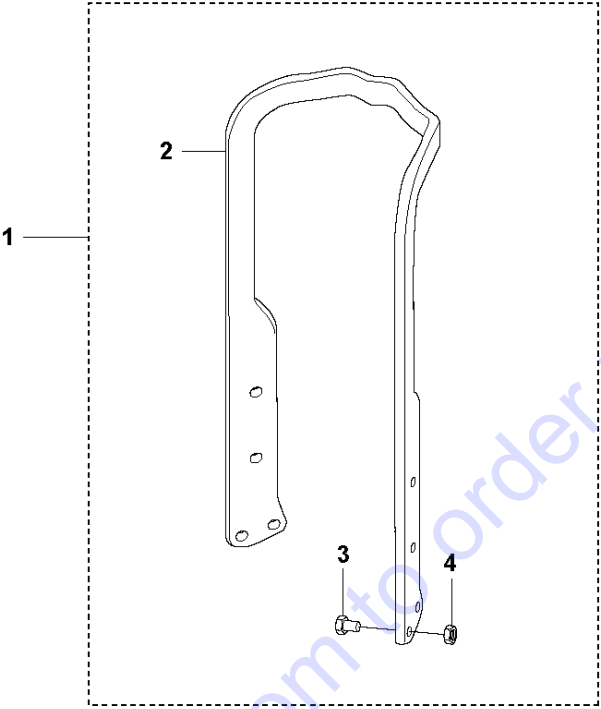

Go to Discounted Equipment.com to order your parts

Ref	Part No	Description	Remark	QTY KIT	
1	598 92 73-01	BRACKET		1	
2	599 00 83-01	BRACKET	36	1	1
3	725 24 53-71	SCREW EHHM	M8 x 25Nm/18ft.lbs	4	
4	522 91 94-01	LOCK NUT	M8, DIN985	4	1

Go to Discount-Equipment.com to order your parts

J CT36-5A
LIFT BRACKET KIT, SHORT

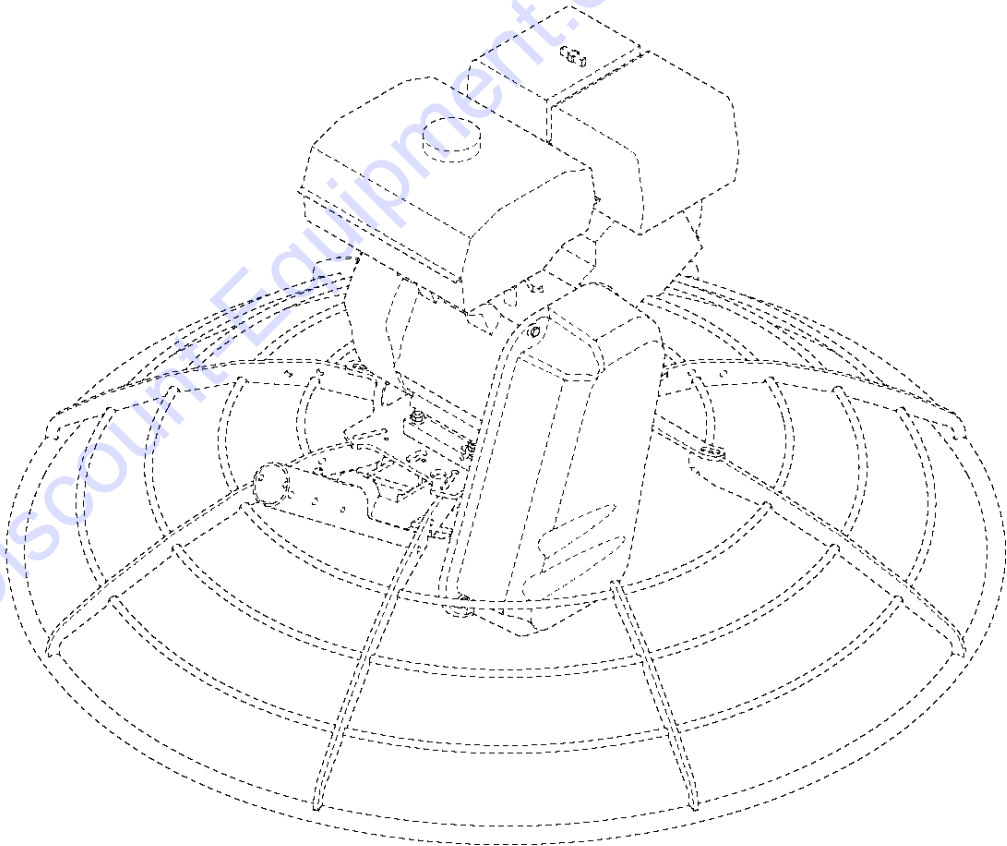
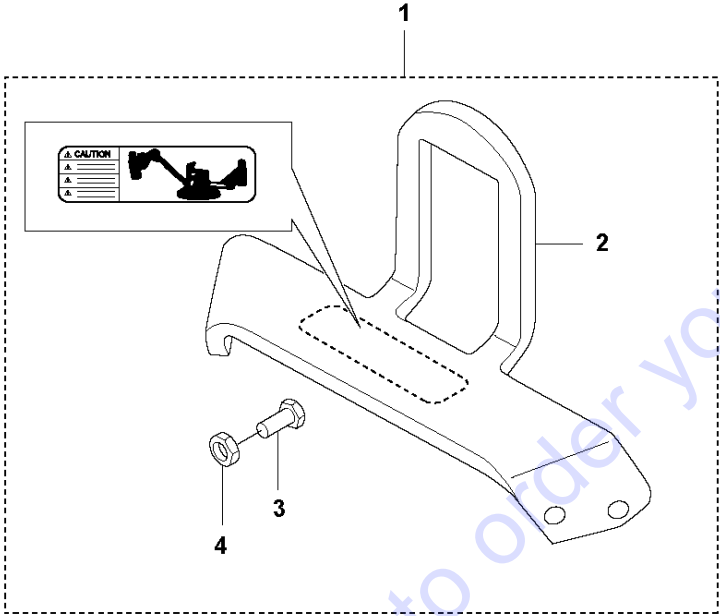

Go to DiscountEquipment.com to order your parts

Ref	Part No	Description	Remark	QTY KIT	
1	598 92 88-01	LIFT	36in	1	
2	599 22 79-01	BRACKET	36in	1	1
3	725 24 53-71	SCREW EHHM	M8x25, ISO4017, ZPB, 25Nm/18ft.lbs	4	1
4	522 91 94-01	LOCK NUT	M8, DIN985	4	1

Go to Discount-Equipment.com to order your parts

K CT36-5A
BOTTLE HOLDER KIT

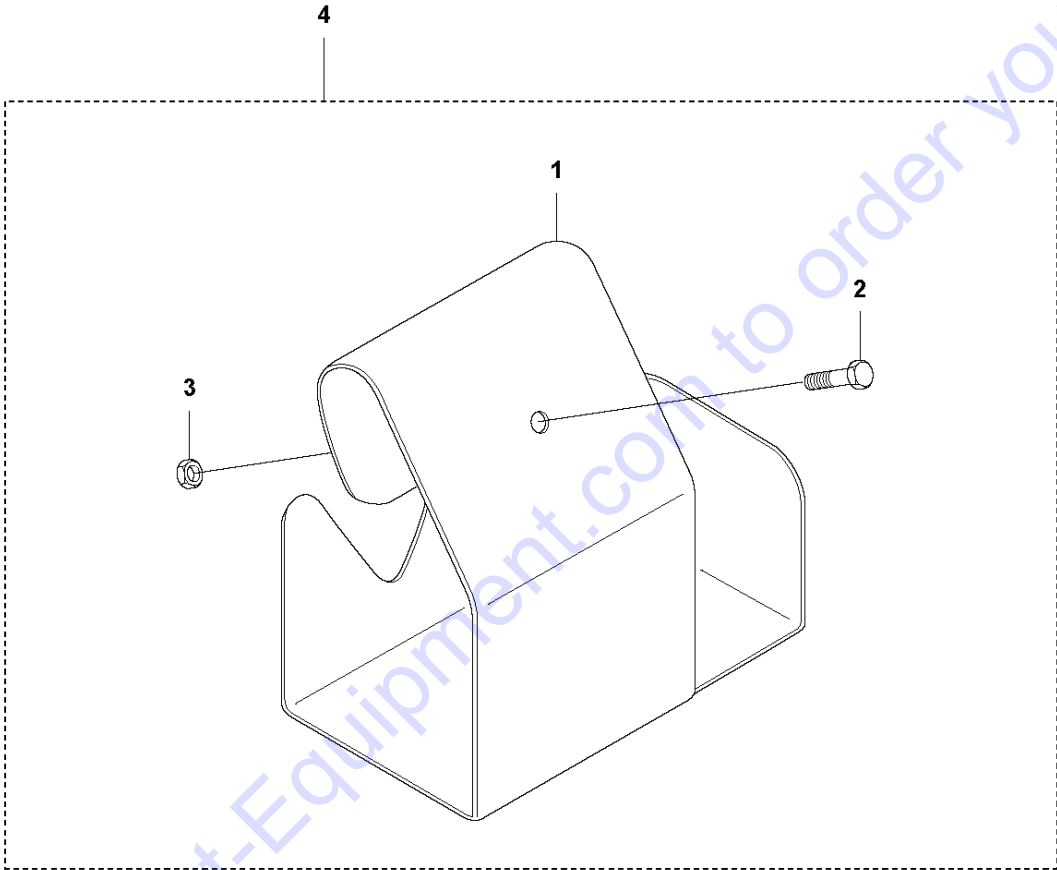

BOTTLE HOLDER KIT

CT36-5A, 2020-02

Ref	Part No	Description	Remark	QTY KIT
1	599 22 80-01	BRACKET		1
2	725 24 64-51	SCREW EHHM	M8x65, ISO4014, Zn, 25Nm/18ft.lbs	2
3	522 91 94-01	LOCK NUT	M8, ISO7040, 6H, A2	2
4	598 92 89-01	BOTTLE HOLDER		1

Go to Discount-Equipment.com to order your parts

L CT36-5A
DECALS

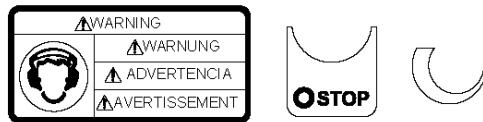
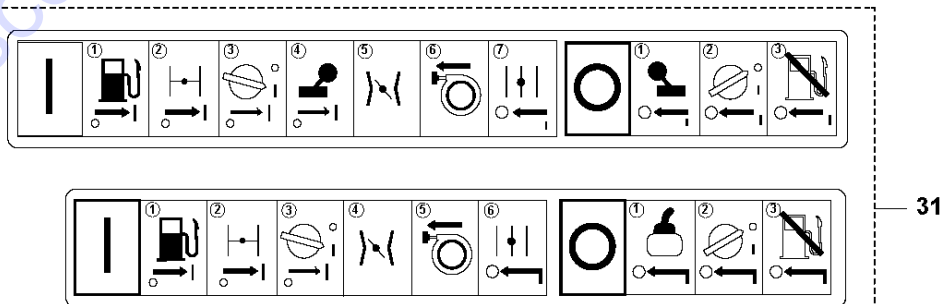
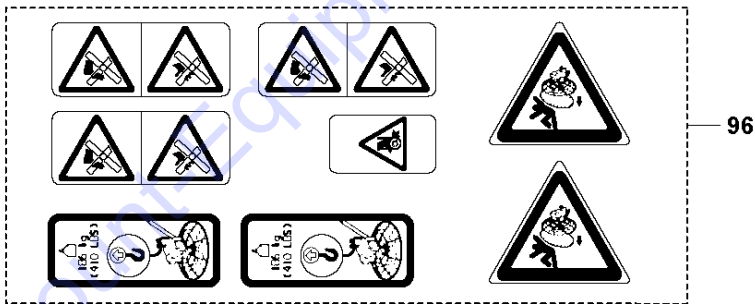
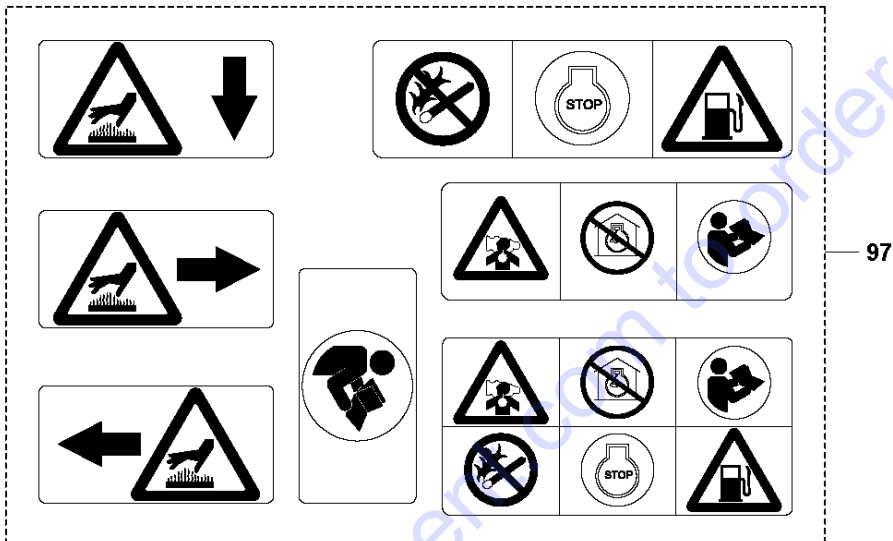
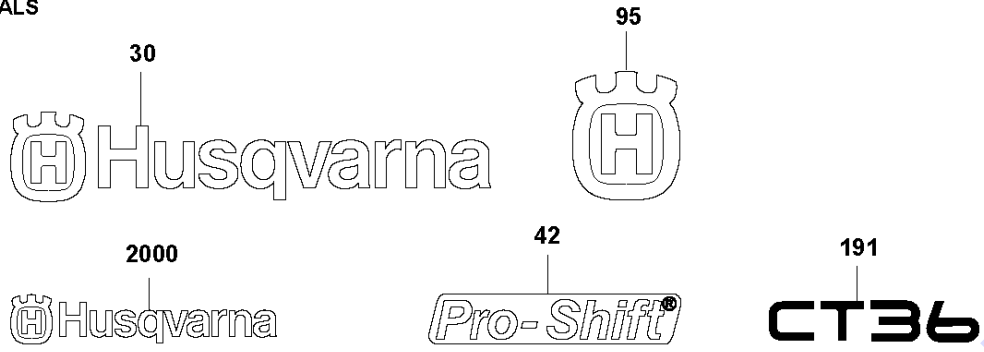

DECALS

CT36-5A, 2020-02

Ref	Part No	Description	Remark	QTY KIT
2000	599 23 45-01	DECAL		1
30	599 07 23-01	LABEL		2
31	599 01 21-01	LABEL		1
42	599 20 85-01	LABEL		1
95	599 07 21-01	LABEL		1
96	599 05 14-01	LABEL		1
97	599 05 13-01	LABEL		1
191	599 04 98-01	LABEL		1

Go to Discount-Equipment.com to order your parts

PARTS FINDER

**Search Website
by Part Number**



**Search Manual
Library For Parts
Manual & Lookup Part
Numbers – Purchase
or Request Quote**

Search Manuals

Enter your information to help us find the right parts manual for your machine.

* Brand:

* Model:

* Serial:

* Part Number:

SEARCH

**Can't Find Part or
Manual? Request Help
by Manufacturer,
Model & Description**

Parts Order Form

Please fill in the following information to help us find the right part for your machine.

Manufacturer:	<input type="text"/>
Model:	<input type="text"/>
Description:	<input type="text"/>
Part Number:	<input type="text"/>
Quantity:	<input type="text"/>
Notes:	<input type="text"/>

Submit

Discount-Equipment.com is your online resource for quality parts & equipment.

Florida: **561-964-4949** Outside Florida TOLL FREE: **877-690-3101**

Need parts?

Click on this link: <http://www.discount-equipment.com/category/5443-parts/> and choose one of the options to help get the right parts and equipment you are looking for. Please have the machine model and serial number available in order to help us get you the correct parts. If you don't find the part on the website or on one of the online manuals, please fill out the request form and one of our experienced staff members will get back to you with a quote for the right part that your machine needs.

We sell worldwide for the brands: Genie, Terex, JLG, MultiQuip, Mikasa, Essick, Whiteman, Mayco, Toro Stone, Diamond Products, Generac Magnum, Airman, Haulotte, Barreto, Power Blanket, Nifty Lift, Atlas Copco, Chicago Pneumatic, Allmand, Miller Curber, Skyjack, Lull, Skytrak, Tsurumi, Husquvarna Target, Stow, Wacker, Sakai, Mi-T-M, Sullair, Basic, Dynapac, MBW, Weber, Bartell, Bennar Newman, Haulotte, Ditch Runner, Menegotti, Morrison, Contec, Buddy, Crown, Edco, Wyco, Bomag, Laymor, EZ Trench, Bil-Jax, F.S. Curtis, Gehl Pavers, Heli, Honda, ICS/PowerGrit, IHI, Partner, Imer, Clipper, MMD, Koshin, Rice, CH&E, General Equipment, Amida, Coleman, NAC, Gradall, Square Shooter, Kent, Stanley, Tamco, Toku, Hatz, Kohler, Robin, Wisconsin, Northrock, Oztec, Toker TK, Rol-Air, APT, Wylie, Ingersoll Rand / Doosan, Innovatech, Con X, Ammann, Mecalac, Makinex, Smith Surface Prep, Small Line, Wanco, Yanmar