



SPARE PARTS LIST

WALL SAWS

WS482 HF, Valid from 20134501537,
2013-11

Go to Discount-Equipment.com to order your parts



PARTS FINDER

**Search Website
by Part Number**



**Search Manual
Library For Parts
Manual & Lookup Part
Numbers – Purchase
or Request Quote**

Search Manuals

Enter your information to help us find the right parts manual for your machine.

* Brand:

* Model:

* Serial:

* Part Number:

SEARCH

**Can't Find Part or
Manual? Request Help
by Manufacturer,
Model & Description**

Parts Order Form

Please fill in the following information to help us find the right part for your machine.

Manufacturer:	<input type="text"/>
Model:	<input type="text"/>
Description:	<input type="text"/>
Part Number:	<input type="text"/>
Quantity:	<input type="text"/>
Notes:	<input type="text"/>

Submit

Discount-Equipment.com is your online resource for quality parts & equipment.

Florida: **561-964-4949** Outside Florida TOLL FREE: **877-690-3101**

Need parts?

Click on this link: <http://www.discount-equipment.com/category/5443-parts/> and choose one of the options to help get the right parts and equipment you are looking for. Please have the machine model and serial number available in order to help us get you the correct parts. If you don't find the part on the website or on one of the online manuals, please fill out the request form and one of our experienced staff members will get back to you with a quote for the right part that your machine needs.

We sell worldwide for the brands: Genie, Terex, JLG, MultiQuip, Mikasa, Essick, Whiteman, Mayco, Toro Stone, Diamond Products, Generac Magnum, Airman, Haulotte, Barreto, Power Blanket, Nifty Lift, Atlas Copco, Chicago Pneumatic, Allmand, Miller Curber, Skyjack, Lull, Skytrak, Tsurumi, Husquvarna Target, Stow, Wacker, Sakai, Mi-T-M, Sullair, Basic, Dynapac, MBW, Weber, Bartell, Bennar Newman, Haulotte, Ditch Runner, Menegotti, Morrison, Contec, Buddy, Crown, Edco, Wyco, Bomag, Laymor, EZ Trench, Bil-Jax, F.S. Curtis, Gehl Pavers, Heli, Honda, ICS/PowerGrit, IHI, Partner, Imer, Clipper, MMD, Koshin, Rice, CH&E, General Equipment, Amida, Coleman, NAC, Gradall, Square Shooter, Kent, Stanley, Tamco, Toku, Hatz, Kohler, Robin, Wisconsin, Northrock, Oztec, Toker TK, Rol-Air, APT, Wylie, Ingersoll Rand / Doosan, Innovatech, Con X, Ammann, Mecalac, Makinex, Smith Surface Prep, Small Line, Wanco, Yanmar

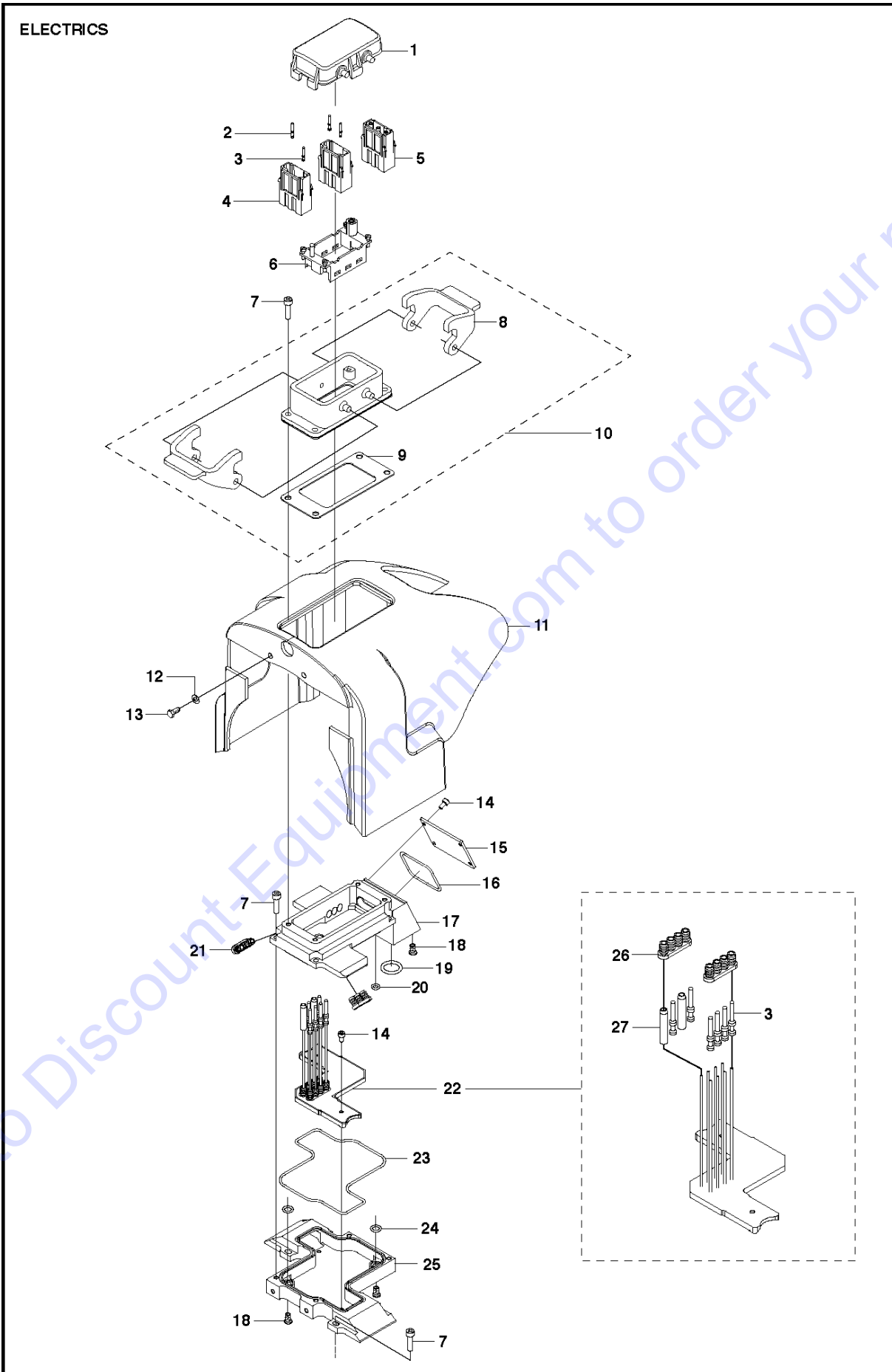

ELECTRICAL

WS482 HF, Valid from 20134501537, 2013-11

Ref	Part No	Description	Remark	QTY KIT
1	575 33 54-01	COVER		1
2	531 11 73-20	TERMINAL		6
3	522 93 08-01	TERMINAL		6
4	522 93 07-01	CONSOLE		2
5	505 53 81-01	CONSOLE		1
6	505 52 89-01	FRAME		1
7	579 25 51-01	SCREW IHSCFMO		12
8	505 24 70-01	SHACKLE		2
9	575 39 41-01	GASKET		1
10	505 52 92-01	CONTACT	Incl. 8 - 9	1
11	580 40 54-02	COVER		1
12	734 11 35-71	WASHER		2
13	725 22 87-71	SCREW EHHM		2
14	579 54 85-01	SCREW		6
15	578 37 36-01	CABLE COVER		1
16	576 42 51-01	O-RING		1
17	578 37 35-01	SEALING PLATE		1
18	505 50 58-01	PLUG		3
19	740 43 11-00	O-RING		1
20	740 42 02-00	O-RING		1
21	579 16 47-01	SEALING PLUG		2
22	578 37 34-04	PRINTED CIRCUIT BOARD	Incl. 3, 26 - 27	1
23	574 45 29-01	O-RING		1
24	740 42 04-00	O-RING		2
25	578 37 32-01	ELECTRONIC BOX		1
26	579 16 47-02	SEALING PLUG		2
27	580 42 94-01	CONNECTOR		2

Go to Discount-Equipment.com to order your parts

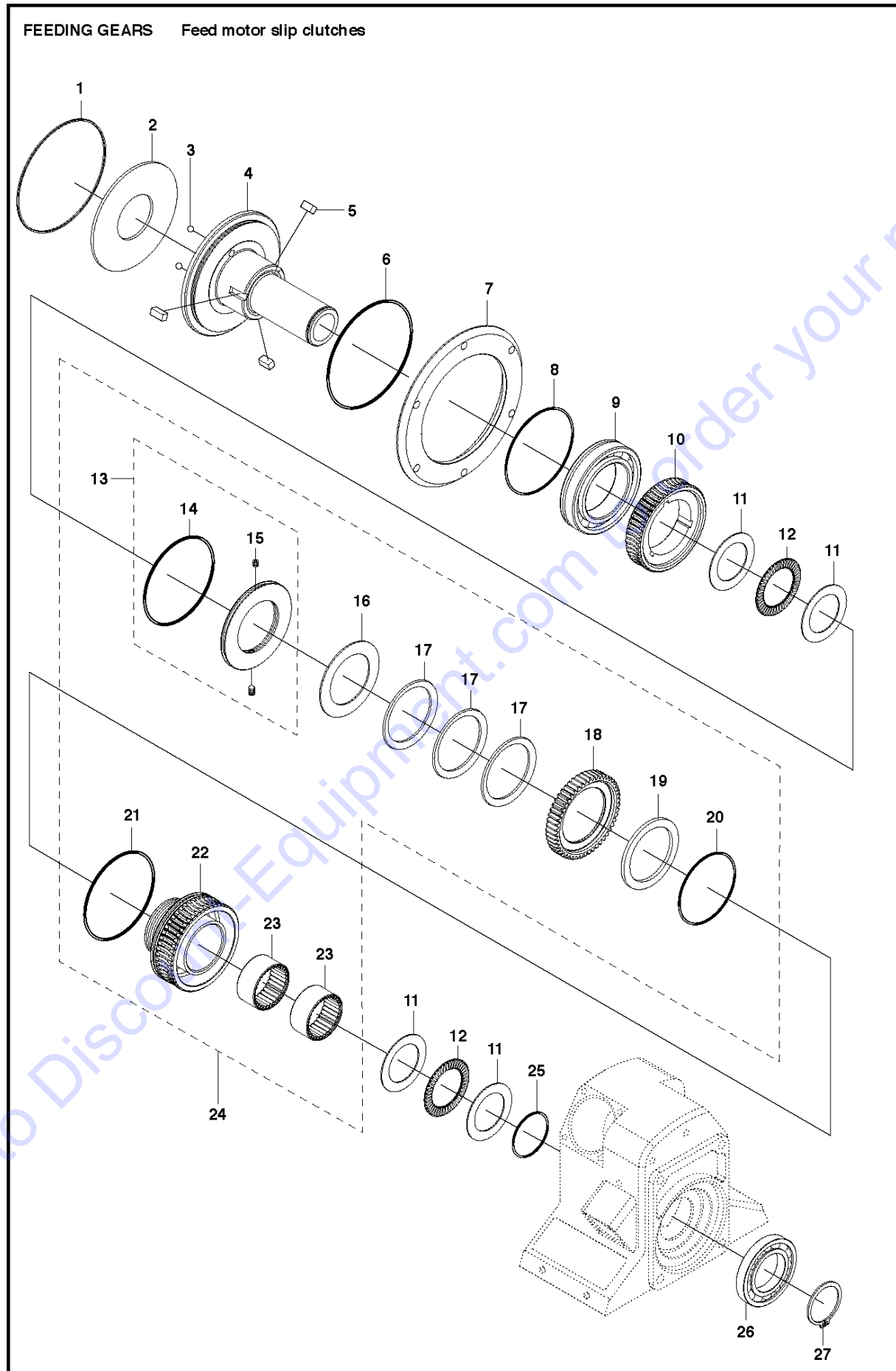

FEEDING GEARS

WS482 HF, Valid from 20134501537, 2013-11

Ref	Part No	Description	Remark	QTY KIT
1	531 11 93-75	O-RING		1
2	531 12 22-80	PLATE		1
3	581 08 40-01	BALL		2
4	574 61 87-01	SHAFT		1
5	574 61 97-01	KEY		3
6	531 11 93-76	O-RING		1
7	574 41 64-01	CLUTCH HUB		1
8	574 45 25-01	O-RING		1
9	580 41 59-01	BEARING		1
10	531 12 30-21	GEAR WHEEL		1
11	531 11 90-39	WASHER		4
12	531 11 90-42	BEARING		2
13	580 42 49-02	NUT	Incl. 14 - 15	1
14	580 41 24-01	O-RING		1
15	728 72 89-05	SCREW IHSETM		2
16	531 11 94-40	BEARING		1
17	531 12 30-25	CUP		3
18	531 12 30-23	GEAR WHEEL		1
19	531 12 30-26	PLATE		1
20	531 11 95-00	O-RING		1
21	531 11 95-04	O-RING		1
22	591 18 70-01	GEAR WHEEL	Incl. 19	1
23	531 11 94-39	BEARING		2
24	531 11 32-71	CLUTCH	Incl. 13 - 23	1
25	531 11 94-50	O-RING		1
26	531 11 94-43	BEARING		1
27	735 31 33-00	CIRCLIP		1

Go to Discount-Equipment.com to order your parts

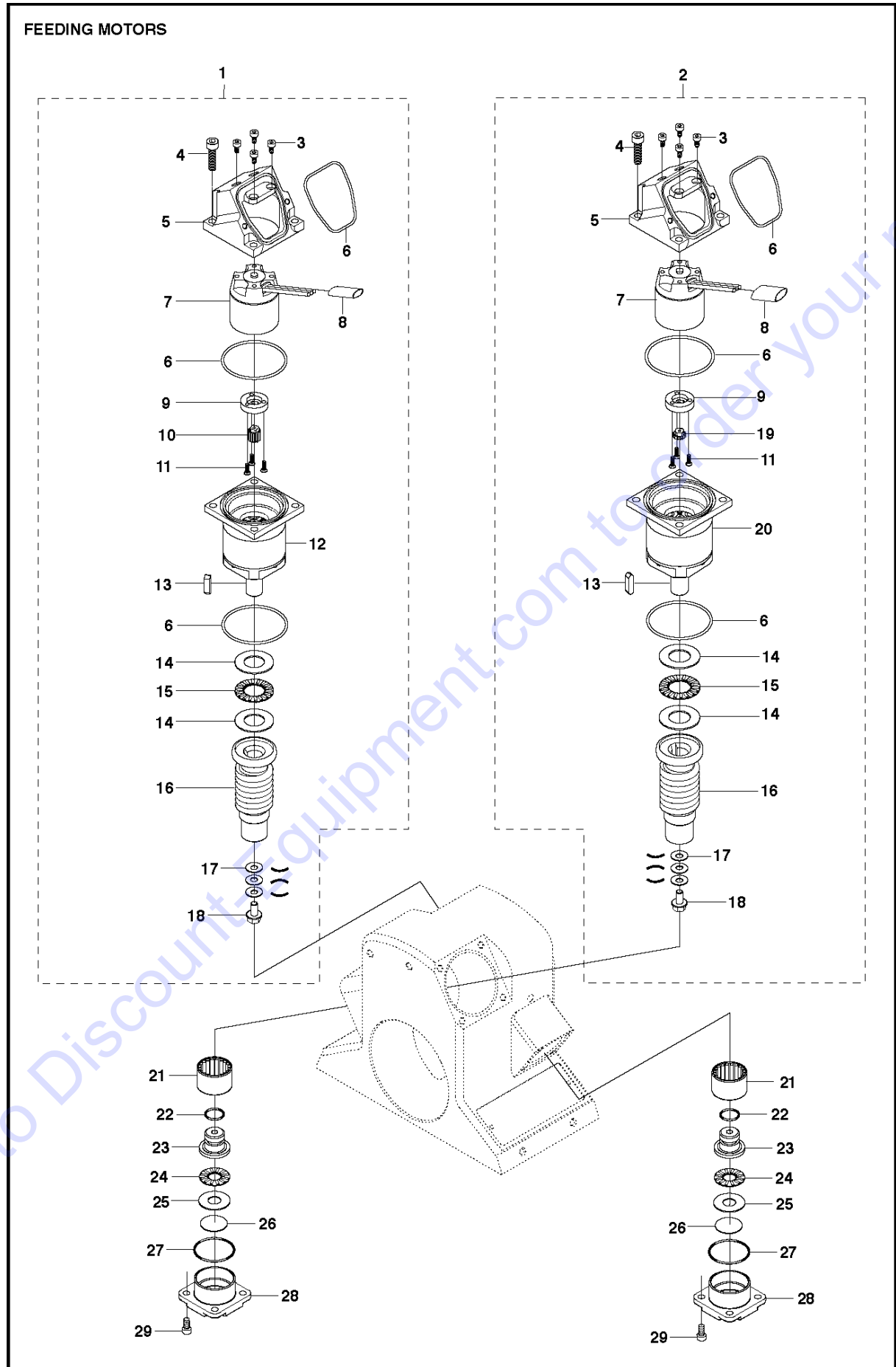

FEEDING MOTORS

WS482 HF, Valid from 20134501537, 2013-11

Ref	Part No	Description	Remark	QTY KIT
1	580 62 50-01	MOTOR ASSY	Incl. 3 - 18	1
2	580 62 51-01	MOTOR ASSY	Incl. 3-9,11,13-18, 19-20	1
3	725 52 20-01	SCREW IHSCM		8
4	725 53 31-01	SCREW IHSCM		8
5	578 37 31-01	MOTOR HOUSING		2
6	531 11 92-82	O-RING		6
7	505 53 86-01	ELECTRIC BOX		2
8	580 49 93-01	HOSE KIT		2
9	531 12 32-27	SHAFT		2
10	531 12 32-36	GEAR WHEEL		1
11	723 51 93-51	SCREW		6
12	581 78 38-01	GEARBOX		1
13	531 11 93-02	KEY		2
14	531 11 94-46	WASHER		4
15	531 11 91-50	BEARING		2
16	531 12 30-28	AUTOMATIC FEEDING SYSTEM		2
17	510 00 71-01	SPRING WASHER		6
18	531 11 95-79	SCREW		2
19	531 12 32-34	GEAR WHEEL		1
20	581 78 37-01	GEARBOX		1
21	531 11 91-55	BEARING		2
22	740 43 09-00	O-RING		2
23	531 12 20-34	AXLE		2
24	531 11 91-49	BEARING		2
25	531 11 91-46	BEARING		2
26	531 11 91-58	SHIM		2
27	531 11 92-77	O-RING		2
28	531 12 30-55	BLOCK		2
29	531 11 92-28	SCREW		8

Go to Discount-Equipment.com to order your parts

HOSES

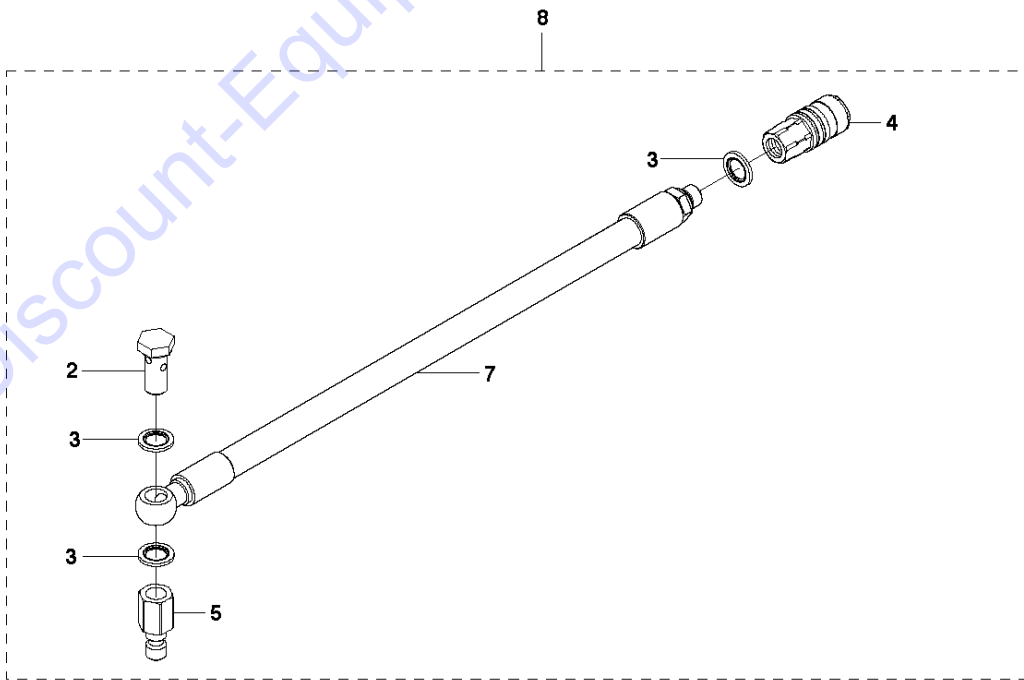
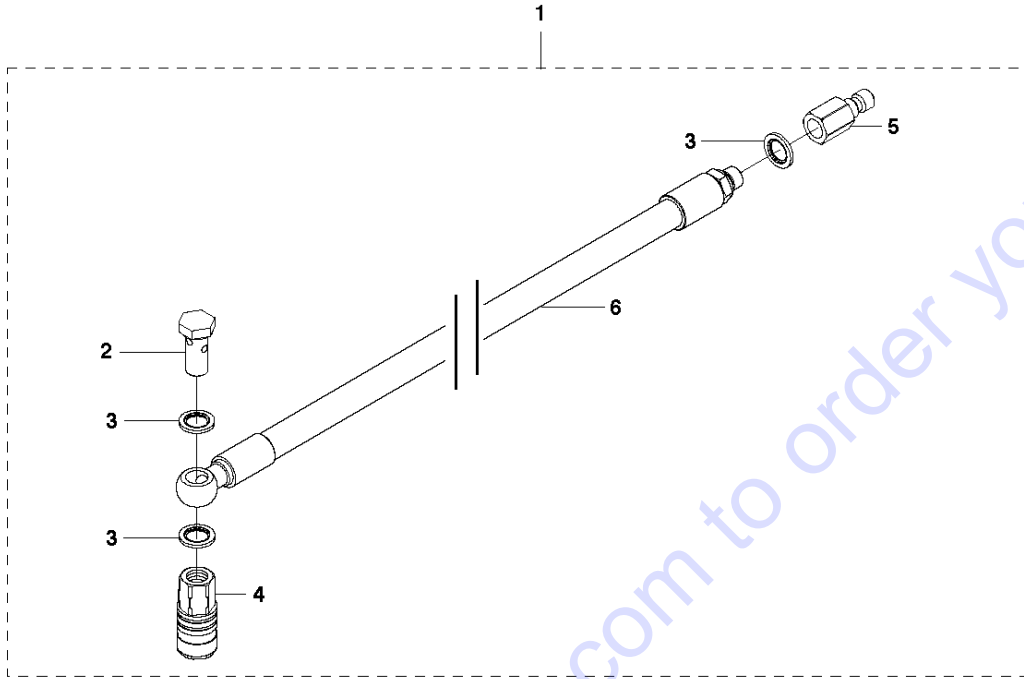

Go to Discount-Equipment.com to order your parts

HOSE

WS482 HF, Valid from 20134501537, 2013-11

Ref	Part No	Description	Remark	QTY KIT
1	505 11 53-01	HOSE	8 m, Incl. 2 - 6	1
2	531 11 83-05	SCREW		2
3	740 38 27-01	SEALING WASHER		6
4	531 11 82-19	QUICK COUPLING		2
5	531 11 82-18	QUICK COUPLING		2
6	505 21 83-01	HOSE		1
7	505 21 82-01	HOSE		1
8	505 21 84-01	HOSE	1 m, Incl. 2 - 5, 8	1

Go to Discount-Equipment.com to order your parts

HOUSING

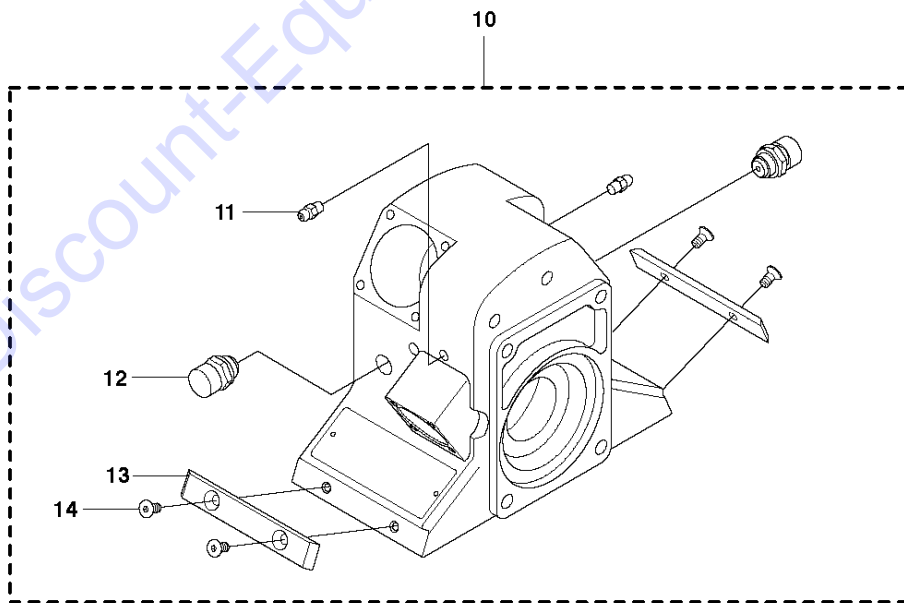
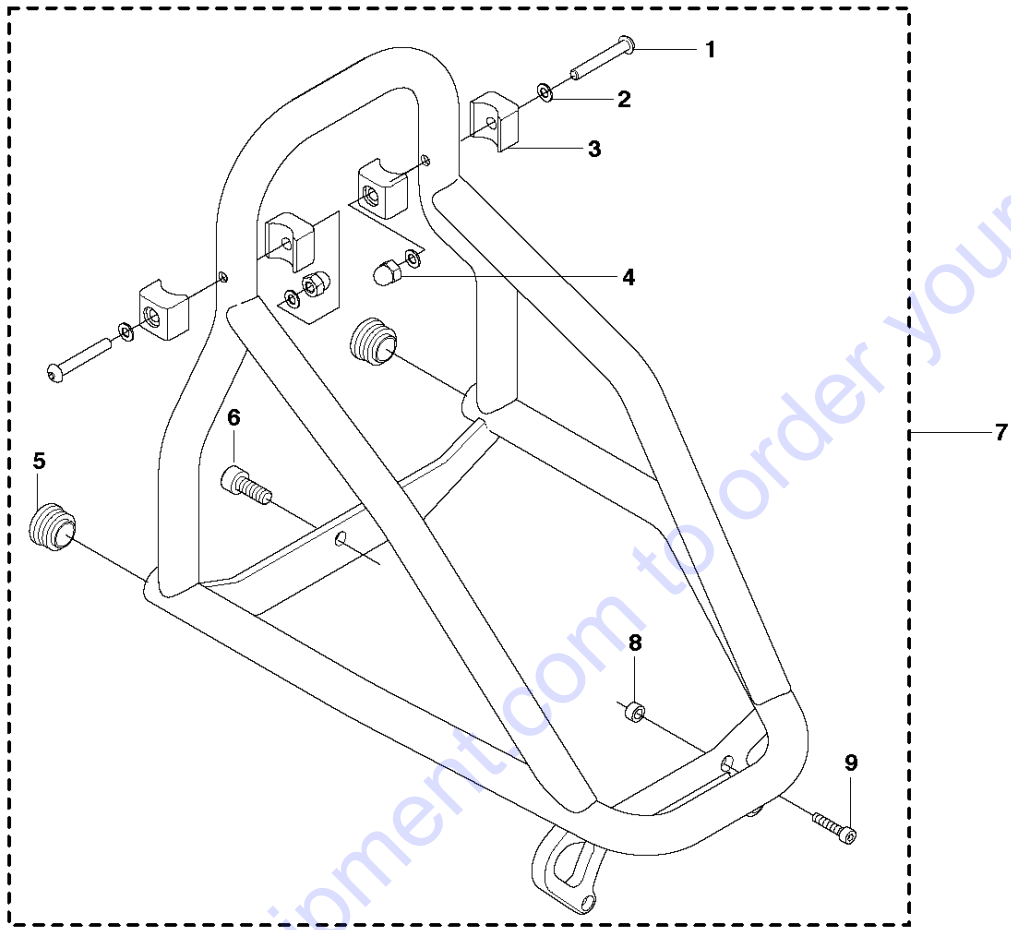

HOUSING

WS482 HF, Valid from 20134501537, 2013-11

Ref	Part No	Description	Remark	QTY	KIT
1	531 11 95-44	SCREW		2	7
2	734 11 52-01	WASHER		4	7
3	574 26 34-01	BLOCK		4	7
4	531 11 92-49	CAP NUT		2	7
5	505 55 56-01	PLUG		2	7
6	725 54 51-01	SCREW IHSCM		2	7
7	592 89 64-01	HANDLEBAR ASSY	Incl. 1 - 6 , 8 - 9	1	
8	577 88 62-01	SPACER		4	7
9	725 53 33-01	SCREW IHSCM		4	7
10	583 87 19-01	HOUSING ASSY	Incl. 11 - 14	1	
11	577 40 11-01	GREASE		2	10
12	583 87 18-01	VENTILATING VALVE		2	10
13	531 12 30-20	PLATE		2	10
14	725 63 27-51	SCREW IHCSFM		4	10

Go to Discount-Equipment.com to order your parts

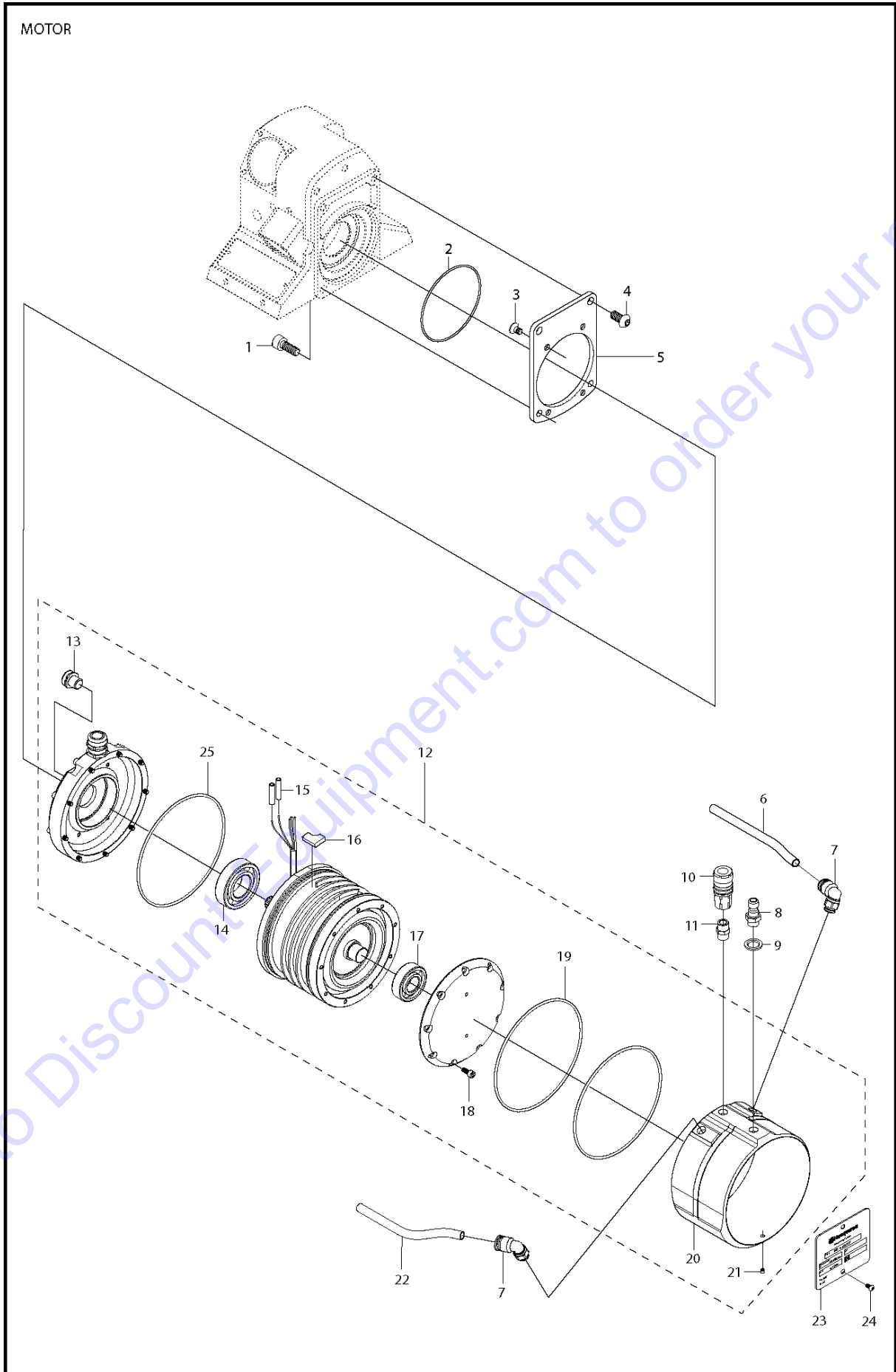

MOTOR

WS482 HF, Valid from 20134501537, 2013-11

Ref	Part No	Description	Remark	QTY	KIT
1	725 54 53-01	SCREW IHSCM		2	
2	531 11 92-93	O-RING		1	
3	725 63 66-51	SCREW IHCSFM		4	
4	531 11 95-11	SCREW		2	
5	531 12 32-14	MOUNTING PLATE		1	
6	575 30 39-02	TUBE	165 mm	1	
7	531 11 82-90	COUPLING		2	
8	505 53 80-01	QUICK COUPLING		1	
9	740 38 27-01	SEALING WASHER		1	
10	531 11 82-19	QUICK COUPLING		1	
11	531 11 83-56	ADAPTER		1	
12	580 65 70-01	MOTOR ASSY	Incl. 13 - 21	1	
13	505 52 84-01	VENTILATING VALVE		1	
14	522 83 94-01	BEARING		1	
15	579 16 48-01	CONNECTOR		2	
16	574 47 63-01	WATER SEPARATOR		1	
17	522 83 95-01	BEARING		1	
18	725 53 27-01	SCREW IHSCM		5	
19	505 24 66-01	O-RING		2	
20	522 78 60-01	TUBE		1	
21	728 83 21-05	SCREW IHSETM		1	
22	575 30 39-03	TUBE	175 mm	1	
23	583 85 64-01	TYPE PLATE		1	
24	516 04 33-01	SCREW		2	
25	589 36 06-01	O-RING		1	12

Go to Discount-Equipment.com to order your parts

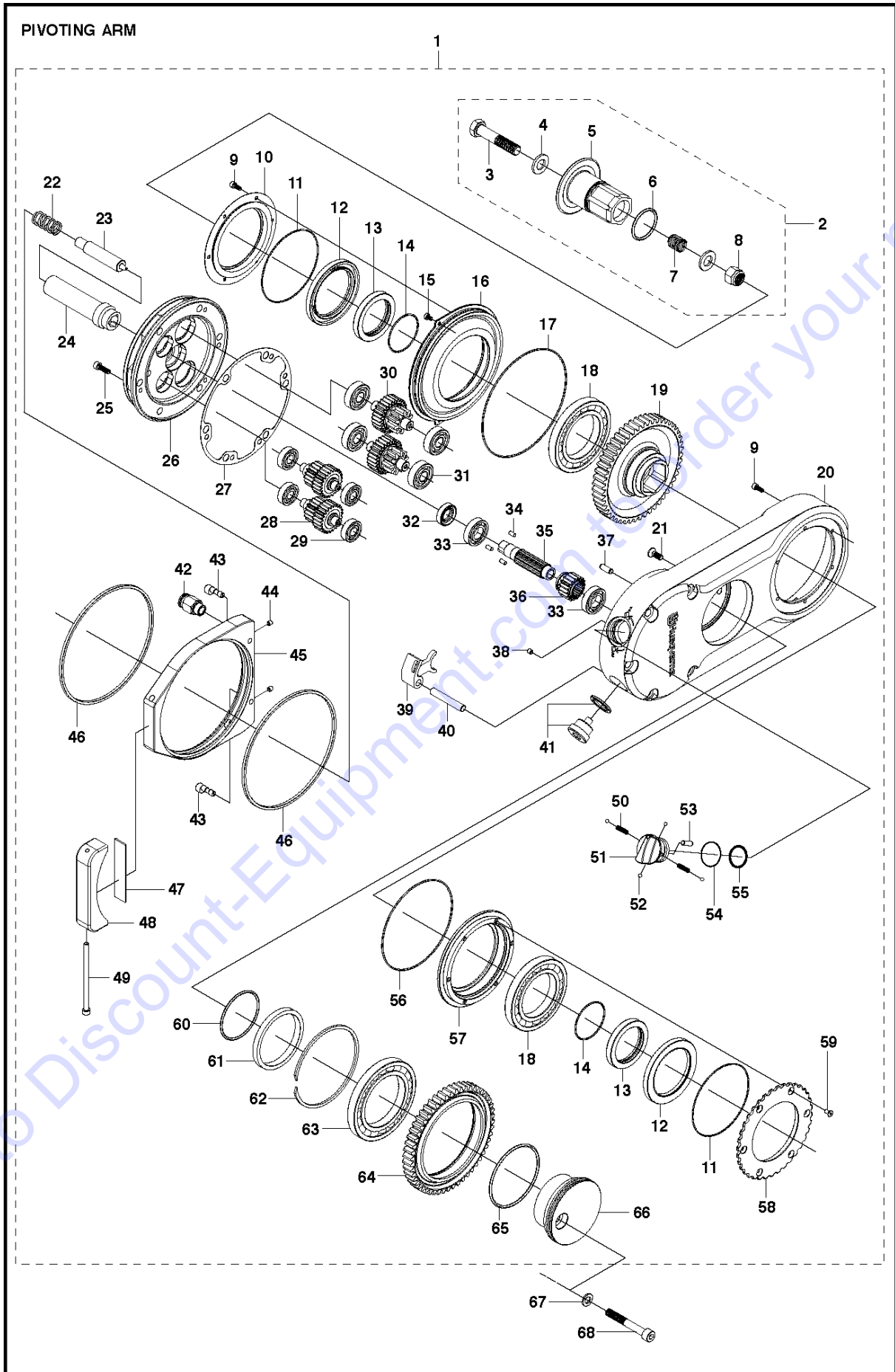

PIVOTING ARM

WS482 HF, Valid from 20134501537, 2013-11

Ref	Part No	Description	Remark	QTY KIT
1	580 72 38-01	PIVOTING ARM	Incl. 2 - 66	1
2	580 67 79-01	SHAFT ASSY	Incl. 3 - 8	1
3	725 25 44-91	SCREW EHHM		1
4	531 11 91-83	WASHER		2
5	531 12 30-35	SHAFT		1
6	531 11 92-74	O-RING		1
7	531 11 93-64	SPRING		1
8	732 25 22-71	HEXAGON LOCKING NUT		1
9	725 52 89-01	SCREW IHSCM		12
10	529 28 11-01	REAR COVER		1
11	574 45 26-01	O-RING		2
12	574 45 22-01	SEAL		2
13	574 44 39-01	RING		2
14	574 45 24-01	O-RING		2
15	506 06 85-01	SCREW		2
16	529 28 12-01	BEARING COVER		1
17	531 11 93-60	O-RING		1
18	574 45 21-01	BEARING		2
19	529 28 20-01	GEAR WHEEL		1
20	580 41 82-01	PIVOTING ARM		1
21	579 56 58-01	SCREW		1
22	505 40 03-08	CASE	Spring	1
23	576 72 06-01	SPACER		1
24	522 52 52-01	SHAFT ASSY		1
25	725 53 29-01	SCREW IHSCM		3
26	522 52 61-01	GEAR		1
27	522 72 01-01	GASKET		1
28	574 64 84-01	GEAR ASSY		2
29	525 58 48-01	BEARING		4
30	580 63 79-01	GEAR ASSY		2
31	525 58 50-01	BEARING		4
32	525 58 54-01	RADIAL SEAL		1
33	525 58 51-01	BEARING		1
34	574 45 18-01	PEN		3
35	576 74 40-01	GEAR WHEEL SHAFT		1
36	522 52 54-01	GEAR WHEEL SHAFT		1
37	720 13 51-50	PARALLEL PIN		1
38	525 58 56-01	SCREW		1
39	522 52 59-01	GEARSHIFT LEVER		1
40	531 11 94-63	PIN		1
41	531 11 81-13	PLUG		1
42	531 11 81-20	COUPLING		2
43	575 32 05-01	ADJUSTMENT DEVICE		2
44	576 38 66-01	STOP SCREW		2
45	574 64 85-01	COOLING AIR CONDUCTOR		1
46	574 45 58-01	RADIAL SEAL		2
47	575 49 15-01	DAMPER		1
48	575 49 11-01	PROTECTOR BAR		1
49	575 49 14-01	SCREW		1
50	525 58 52-01	SPRING		2
51	580 41 83-01	KNOB		1
52	531 11 93-66	ROLLERBALL		4
53	720 13 08-50	PARALLEL PIN		1
54	740 44 05-00	O-RING		1
55	525 58 53-01	O-RING		1
56	574 45 29-01	O-RING		1
57	529 28 14-01	BEARING CAGE		1
58	529 28 17-01	COVER LID		1
59	725 62 87-01	SCREW IHCSFM		6
60	574 45 30-01	O-RING		1
61	522 52 64-01	INTERLAYER		1
62	574 45 32-01	SNAP RING		1
63	574 45 20-01	BEARING		1
64	522 52 62-02	DRIVER		1
65	531 11 94-51	O-RING		1
66	522 52 63-01	MANIFOLD		1
67	734 11 63-01	WASHER		6
68	725 54 64-01	SCREW IHSCM		6

PARTS FINDER

**Search Website
by Part Number**



**Search Manual
Library For Parts
Manual & Lookup Part
Numbers – Purchase
or Request Quote**

Search Manuals

Enter your information to help us find the right parts manual for your machine.

* Brand:

* Model:

* Serial:

* Part Number:

SEARCH

**Can't Find Part or
Manual? Request Help
by Manufacturer,
Model & Description**

Parts Order Form

Please fill in the following information to help us find the right part for your machine.

Manufacturer:	<input type="text"/>
Model:	<input type="text"/>
Description:	<input type="text"/>
Part Number:	<input type="text"/>
Quantity:	<input type="text"/>
Notes:	<input type="text"/>

Submit

Discount-Equipment.com is your online resource for quality parts & equipment.

Florida: **561-964-4949** Outside Florida TOLL FREE: **877-690-3101**

Need parts?

Click on this link: <http://www.discount-equipment.com/category/5443-parts/> and choose one of the options to help get the right parts and equipment you are looking for. Please have the machine model and serial number available in order to help us get you the correct parts. If you don't find the part on the website or on one of the online manuals, please fill out the request form and one of our experienced staff members will get back to you with a quote for the right part that your machine needs.

We sell worldwide for the brands: Genie, Terex, JLG, MultiQuip, Mikasa, Essick, Whiteman, Mayco, Toro Stone, Diamond Products, Generac Magnum, Airman, Haulotte, Barreto, Power Blanket, Nifty Lift, Atlas Copco, Chicago Pneumatic, Allmand, Miller Curber, Skyjack, Lull, Skytrak, Tsurumi, Husquvarna Target, Stow, Wacker, Sakai, Mi-T-M, Sullair, Basic, Dynapac, MBW, Weber, Bartell, Bennar Newman, Haulotte, Ditch Runner, Menegotti, Morrison, Contec, Buddy, Crown, Edco, Wyco, Bomag, Laymor, EZ Trench, Bil-Jax, F.S. Curtis, Gehl Pavers, Heli, Honda, ICS/PowerGrit, IHI, Partner, Imer, Clipper, MMD, Koshin, Rice, CH&E, General Equipment, Amida, Coleman, NAC, Gradall, Square Shooter, Kent, Stanley, Tamco, Toku, Hatz, Kohler, Robin, Wisconsin, Northrock, Oztec, Toker TK, Rol-Air, APT, Wylie, Ingersoll Rand / Doosan, Innovatech, Con X, Ammann, Mecalac, Makinex, Smith Surface Prep, Small Line, Wanco, Yanmar