



Count on it.

Parts Catalog

STX-26

Stump Grinder

Model No. 23208—Serial No. 410480000 and Up

Go to Discount-Equipment.com to order your parts



www.discount-equipment.com



PARTS FINDER

**Search Website
by Part Number**



**Search Manual
Library For Parts
Manual & Lookup Part
Numbers – Purchase
or Request Quote**

Search Manuals

Enter your information to help us find the right parts manual for your machine.

* Brand:

* Model:

* Serial:

* Part Number:

SEARCH

**Can't Find Part or
Manual? Request Help
by Manufacturer,
Model & Description**

Parts Order Form

Please fill in the following information to help us find the right part for your machine.

Manufacturer:	<input type="text"/>
Model:	<input type="text"/>
Description:	<input type="text"/>
Part Number:	<input type="text"/>
Quantity:	<input type="text"/>
Notes:	<input type="text"/>

Discount-Equipment.com is your online resource for quality parts & equipment.

Florida: **561-964-4949** Outside Florida TOLL FREE: **877-690-3101**

Need parts?

Click on this link: <http://www.discount-equipment.com/category/5443-parts/> and choose one of the options to help get the right parts and equipment you are looking for. Please have the machine model and serial number available in order to help us get you the correct parts. If you don't find the part on the website or on one of the online manuals, please fill out the request form and one of our experienced staff members will get back to you with a quote for the right part that your machine needs.

We sell worldwide for the brands: Genie, Terex, JLG, MultiQuip, Mikasa, Essick, Whiteman, Mayco, Toro Stone, Diamond Products, Generac Magnum, Airman, Haulotte, Barreto, Power Blanket, Nifty Lift, Atlas Copco, Chicago Pneumatic, Allmand, Miller Curber, Skyjack, Lull, Skytrak, Tsurumi, Husquvarna Target, Stow, Wacker, Sakai, Mi-T-M, Sullair, Basic, Dynapac, MBW, Weber, Bartell, Bennar Newman, Haulotte, Ditch Runner, Menegotti, Morrison, Contec, Buddy, Crown, Edco, Wyco, Bomag, Laymor, EZ Trench, Bil-Jax, F.S. Curtis, Gehl Pavers, Heli, Honda, ICS/PowerGrit, IHI, Partner, Imer, Clipper, MMD, Koshin, Rice, CH&E, General Equipment, Amida, Coleman, NAC, Gradall, Square Shooter, Kent, Stanley, Tamco, Toku, Hatz, Kohler, Robin, Wisconsin, Northrock, Oztec, Toker TK, Rol-Air, APT, Wylie, Ingersoll Rand / Doosan, Innovatech, Con X, Ammann, Mecalac, Makinex, Smith Surface Prep, Small Line, Wanco, Yanmar

Ordering Replacement Parts

To order replacement parts, please supply the part number, the quantity, and the description of each part desired.

Understanding Reference Numbers

Each identified part in an illustration has a reference number. The reference number for a part also appears in the parts list, along with other information about the part.

This catalog uses two special reference number formats, one to indicate parts in a service assembly and another to indicate the quantity of a given part in an illustration.

Service Assembly Reference Numbers

Parts in service assemblies have reference numbers in the form a:b. The a represents the reference number of the entire service assembly and the b represents a sequential number unique to each part within the service assembly.

For example, a wheel assembly might be identified by reference number 6, the tire by 6:1, the valve by 6:2, and the wheel by 6:3. When you order the assembly identified by reference number 6, you receive all parts identified by reference numbers 6:1, 6:2, and 6:3. However, you may also order any part individually. Reference numbers of this type appear in illustration and in parts lists.

Reference Numbers Indicating Quantity

In an illustration, if a reference number indicates more than one part, the reference number has the form nX y. The n represents the quantity of the part, the X is the multiplication symbol, and the y represents the reference number.

For example, in an illustration, the reference number 2X 37 means that two of the parts identified by reference number 37 are indicated.

Go to Discount-Equipment.com to order your parts

Contents

Frame Assembly	4
Track and Drive Assembly	6
Hydraulic Pump Assembly No. 117-6409	8
Hydraulic Pump Assembly No. 117-6410	9
Hydraulic Motor Assembly No. 119-4557	10
Engine Assembly	12
Hydraulic Gear Pump Assembly No. 117-6444	14
Control Assembly	16
Frame and Cutter Wheel Assembly	18
Hydraulic Motor Assembly No. 127-9603	20
Hydraulic Cylinder Assembly No. 117-6441	21
Hydraulic Cylinder Assembly No. 121-1955	22
Tower and Fuel Tank Assembly	24
Control Valve Assembly	26
Control Valve Assembly No. 119-4585	27
Cutter Wheel Valve Assembly No. 119-4586	28
Two-Button Handle Grip Assembly No. 119-4587	29
Oil Cooler Assembly	30
Hydraulic Hose Routing Assembly	32
Battery and Electrical Assembly	34
Cylinder and Crankcase Assembly	36
Piston and Crankshaft Assembly	37
Valve and Camshaft Assembly	38
Lubrication Equipment Assembly	39
Cooling Equipment Assembly	40
Electric Equipment Assembly	41
Carburetor Assembly	42
Control Equipment Assembly	44
Air Filter and Muffler Assembly	45
Fuel Tank and Valve Assembly	46
Starter Assembly	47
Label Set	48
Attachments and Accessories	49

Frame Assembly

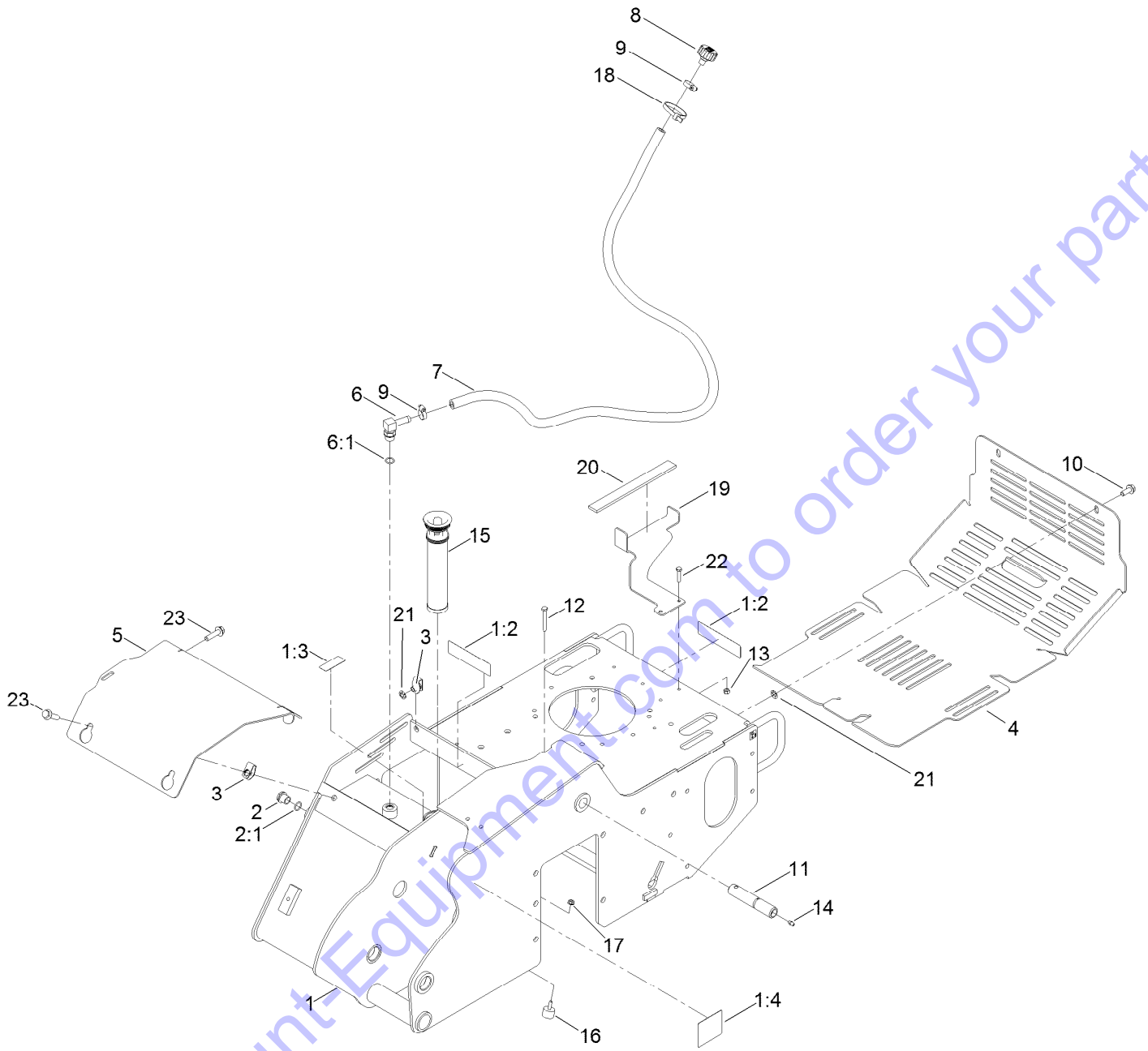

Go to Discount-Equipment.com to order your parts

Frame Assembly (continued)

<i>Ref.</i>	<i>Part Number</i>	<i>Qty.</i>	<i>Description</i>	<i>Ref.</i>	<i>Part Number</i>	<i>Qty.</i>	<i>Description</i>
1	127-9602	1	Main Frame ASM	10	108-1531	2	Screw-HHF
1:2	100-4650	1	Decal-Warning	11	120-7352	1	Pin-Pivot
1:3	93-7814	2	Decal-Danger	12	321-18	1	Screw-HH
1:4	93-6686	1	Decal-Oil, HYD	13	3296-42	3	Nut-Lock, NI
2	114-3075	1	Sight Glass ASM	14	302-5	1	Fitting-Grease
2:1	237-79	1	O-Ring	15	114-3039	1	Filter-Tank, In
3	140-1146	5	Nut-Clip, U	16	1-523420	1	Bumper
4	119-5106-01	1	Cover-Rear	17	32128-33	1	Nut-HF
5	119-4566-03	1	Plate-Cover, Front	18	3334-945	1	Tie-Cable
6	354-120	1	Fitting-Elbow, 90	19	119-5091-01	1	Bracket-Tank
6:1	237-79	1	O-Ring	20	117-6417	1	Pad-Foam
7	114-3042	1	Hose-Breather	21	140-1144	5	Nut-Push
8	68-6150	1	Breather	22	321-8	2	Screw-HH
9	2412-36	2	Clamp-Hose	23	33105-040	3	Screw-HHF

Go to Discount-Equipment.com to order your parts

Track and Drive Assembly

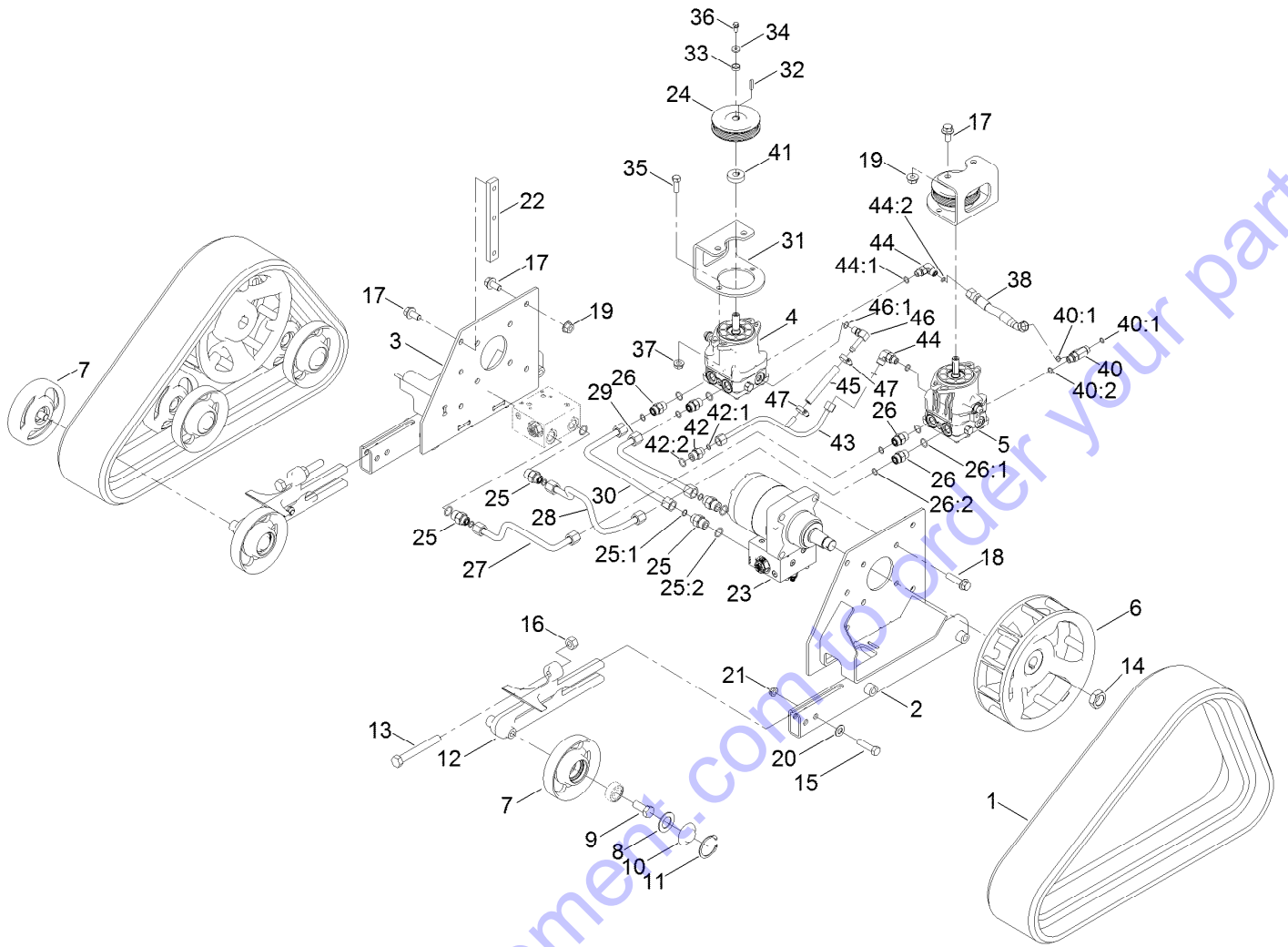

Go to Discount-Equipment.com to order your parts

Track and Drive Assembly (continued)

<i>Ref.</i>	<i>Part Number</i>	<i>Qty.</i>	<i>Description</i>	<i>Ref.</i>	<i>Part Number</i>	<i>Qty.</i>	<i>Description</i>
1	112-4816	2	Track-Rubber	26:1	237-30	1	O-Ring
2	114-2992-03	1	Frame-Track, LH	26:2	237-79	1	O-Ring
3	114-2993-03	1	Frame-Track, RH	27	119-4581	1	Tube-HYD
4	117-6409	1	RH HYD Pump ASM	28	119-4582	1	Tube-HYD
5	117-6410	1	LH HYD Pump ASM	29	119-4583	1	Tube-HYD
6	117-6426-03	2	Wheel-Drive	30	119-4584	1	Tube-HYD
7	138-3139	12	Tensioner Wheel ASM	31	115-1289-03	2	Bracket-Mount, Pump
7:1	138-7118	1	Wheel-Track ●	32	80-6090	2	Key-Pump
7:2	120-5378	1	Bearing-Ball ●	33	108-4211	2	Bushing
8	106-7585	12	Gasket-Bogie	34	73-3580	2	Washer
9	327-4	12	Screw-HH	35	324-5	4	Screw-HH
10	106-7557	12	Cap-Wheel, Bearing	36	33103-016	2	Screw-HHF
11	106-7595	12	Ring-Snap, Internal	37	32128-42	4	Nut-HF
12	114-3077-03	2	Tensioner-Track	38	115-1297	1	Hose-HYD
13	112-4874	2	Screw-HH, TAP	40	340-86	1	Fitting-Tee
14	106-8159	2	Nut-Lock	40:1	237-22	2	O-Ring
15	325-8	4	Screw-HH	40:2	237-42	1	O-Ring
16	3217-11	2	Nut-Hex	41	115-4002	2	Spacer
17	3234-6	14	Screw-HHF	42	340-3	1	Fitting-Straight
18	3234-27	8	Screw-HHF	42:1	237-22	1	O-Ring
19	32128-49	8	Nut-HHF	42:2	237-79	1	O-Ring
20	3256-26	4	Washer-Flat	43	117-1305	1	Tube-HYD
21	3296-45	4	Nut-Hex	44	340-77	2	Fitting-Elbow, 90 DEG
22	114-3091	2	Bar-Thread	44:1	237-22	1	O-Ring
23	119-4557	2	HYD Motor ASM	44:2	237-42	1	O-Ring
24	115-1298	2	Sheave	45	115-4083	1	Hose
25	340-6	4	Fitting-Straight	46	100-4887	1	Fitting-Elbow, 90
25:1	237-30	1	O-Ring	46:1	237-42	1	O-Ring
25:2	237-80	1	O-Ring	47	2412-36	2	Clamp-Hose
26	340-4	4	Fitting-Straight				

● Not illustrated

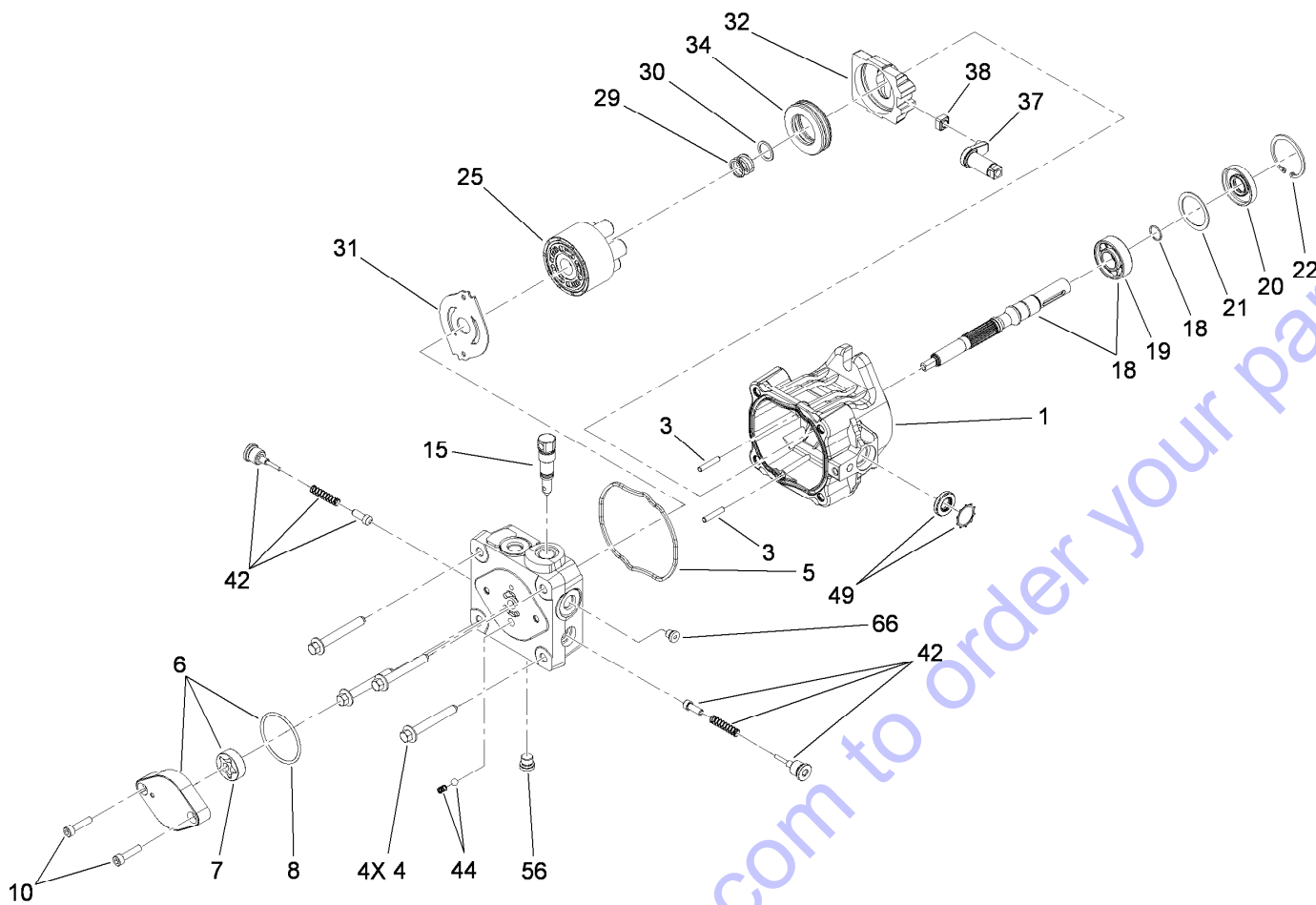

Hydraulic Pump Assembly No. 117-6409

Ref.	Part Number	Qty.	Description	Ref.	Part Number	Qty.	Description
1	115-4464	1	Housing Kit	29	94-1936	1	Spring-Block
3	106-8753	2	Pin-Headless, Straight	30	94-1937	1	Washer-Thrust
4	106-8754	4	Bolt-HF	31	105-6185	1	Plate-Valve
5	106-8755	1	O-Ring	32	94-1907	1	Swashplate-Variable
6	106-8756	1	Charge Pump Kit	34	94-6922	1	Bearing-Thrust
7	104-2122	1	Gerotor ASM	37	115-4458	1	Arm-Trunnion, Tapered Square
8	106-8757	1	O-Ring	38	94-1910	1	Guide-Slot
10	104-2111	2	Capscrew	42	98-3252	2	Valve-Check (W/Poppet)
15	106-8759	1	Bypass Valve Kit	44	106-8760	1	Charge Relief Valve Kit
18	103-2664	1	Input Shaft Kit	49	114-8155	1	Trunnion Seal Kit
19	104-5311	1	Bearing-Ball	56	106-8762	1	Plug-HSH
20	104-5310	1	Seal-Lip	66	106-8763	1	Plug-HSH
21	104-5308	1	Spacer	99	105-6184	1	Seal Overhaul Kit ●
22	104-5309	1	Ring-Retaining				
25	103-2666	1	Cylinder Block Kit				

● Not illustrated

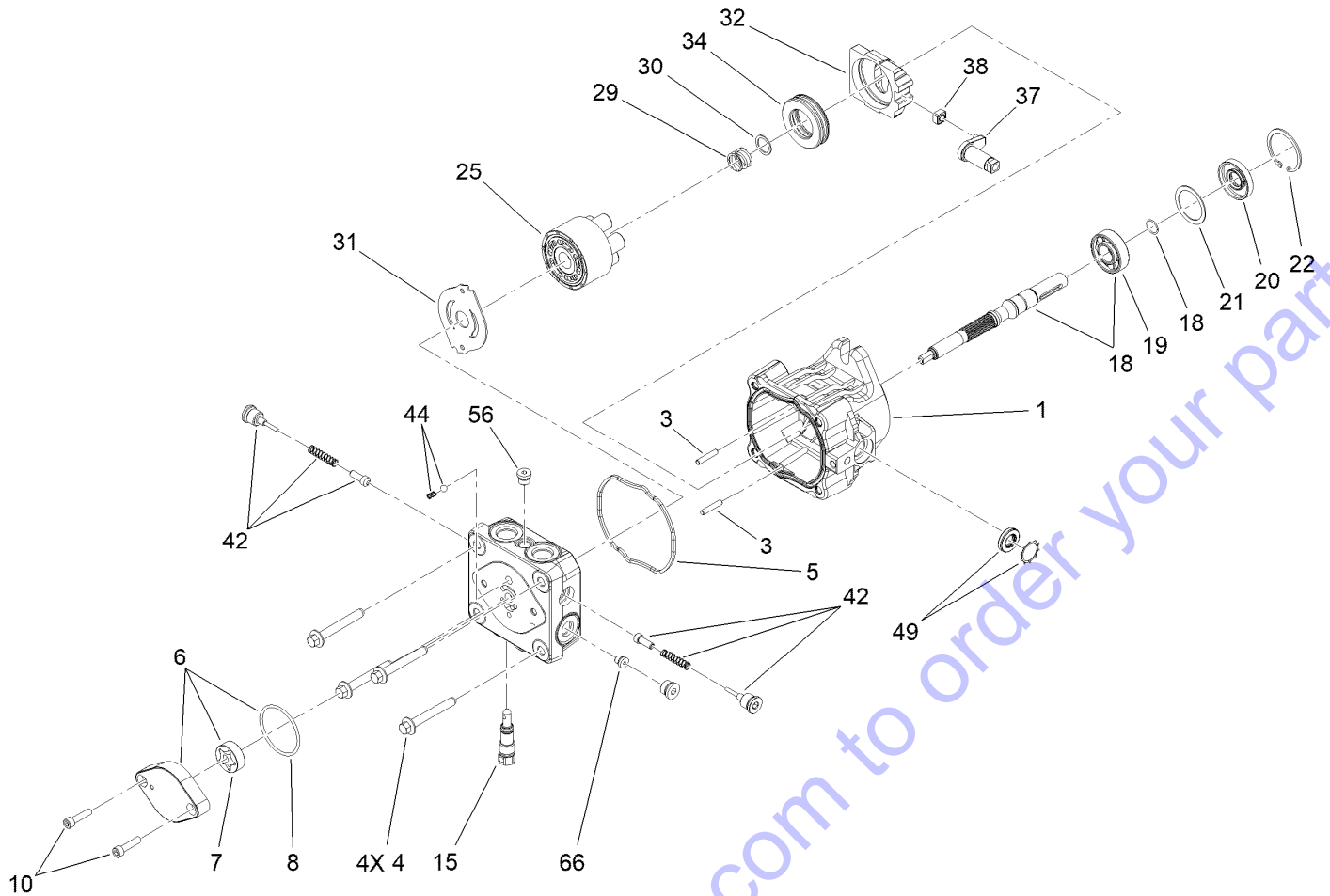

Hydraulic Pump Assembly No. 117-6410

Ref.	Part Number	Qty.	Description	Ref.	Part Number	Qty.	Description
1	115-4464	1	Housing Kit	29	94-1936	1	Spring-Block
3	106-8753	2	Pin-Headless, Straight	30	94-1937	1	Washer-Thrust
4	106-8754	4	Bolt-HF	31	105-6185	1	Plate-Valve
5	106-8755	1	O-Ring	32	94-1907	1	Swashplate-Variable
6	106-8756	1	Charge Pump Kit	34	94-6922	1	Bearing-Thrust
7	104-2122	1	Gerotor ASM	37	115-4458	1	Arm-Trunnion, Tapered Square
8	106-8757	1	O-Ring	38	94-1910	1	Guide-Slot
10	104-2111	2	Capscrew	42	98-3252	2	Valve-Check (W/Poppet)
15	106-8759	1	Bypass Valve Kit	44	106-8760	1	Charge Relief Valve Kit
18	103-2664	1	Input Shaft Kit	49	114-8155	1	Trunnion Seal Kit
19	104-5311	1	Bearing-Ball	56	106-8762	1	Plug-HSH
20	104-5310	1	Seal-Lip	66	106-8763	1	Plug-HSH
21	104-5308	1	Spacer	99	105-6184	1	Seal Overhaul Kit ●
22	104-5309	1	Ring-Retaining				
25	103-2666	1	Cylinder Block Kit				

● Not illustrated

Hydraulic Motor Assembly No. 119-4557 (continued)

<i>Ref.</i>	<i>Part Number</i>	<i>Qty.</i>	<i>Description</i>	<i>Ref.</i>	<i>Part Number</i>	<i>Qty.</i>	<i>Description</i>
1	119-4599	1	Counterbalance Valve ASM	7	100-6131	1	Seal Kit ●
1:1	119-4608	2	Valve-Cartridge	7:1		1	Ring-Back Up ■
2	119-4611	4	Bolt-HSH	7:2		1	Washer-Back Up ■
3	3257-42	1	Key-Woodruff	7:3		1	Seal-Shaft ■
4	120-0691	2	O-Ring	7:4		5	Seal-Ring ■
5	76-0860	1	Shaft-Coupling	7:5		1	Seal-Commutator ■
6	120-5394	1	Motor Housing ASM	7:6		1	Seal-Dirt And Water ■

Go to Discount-Equipment.com to order your parts

● Not illustrated

■ Not serviced separately

Engine Assembly

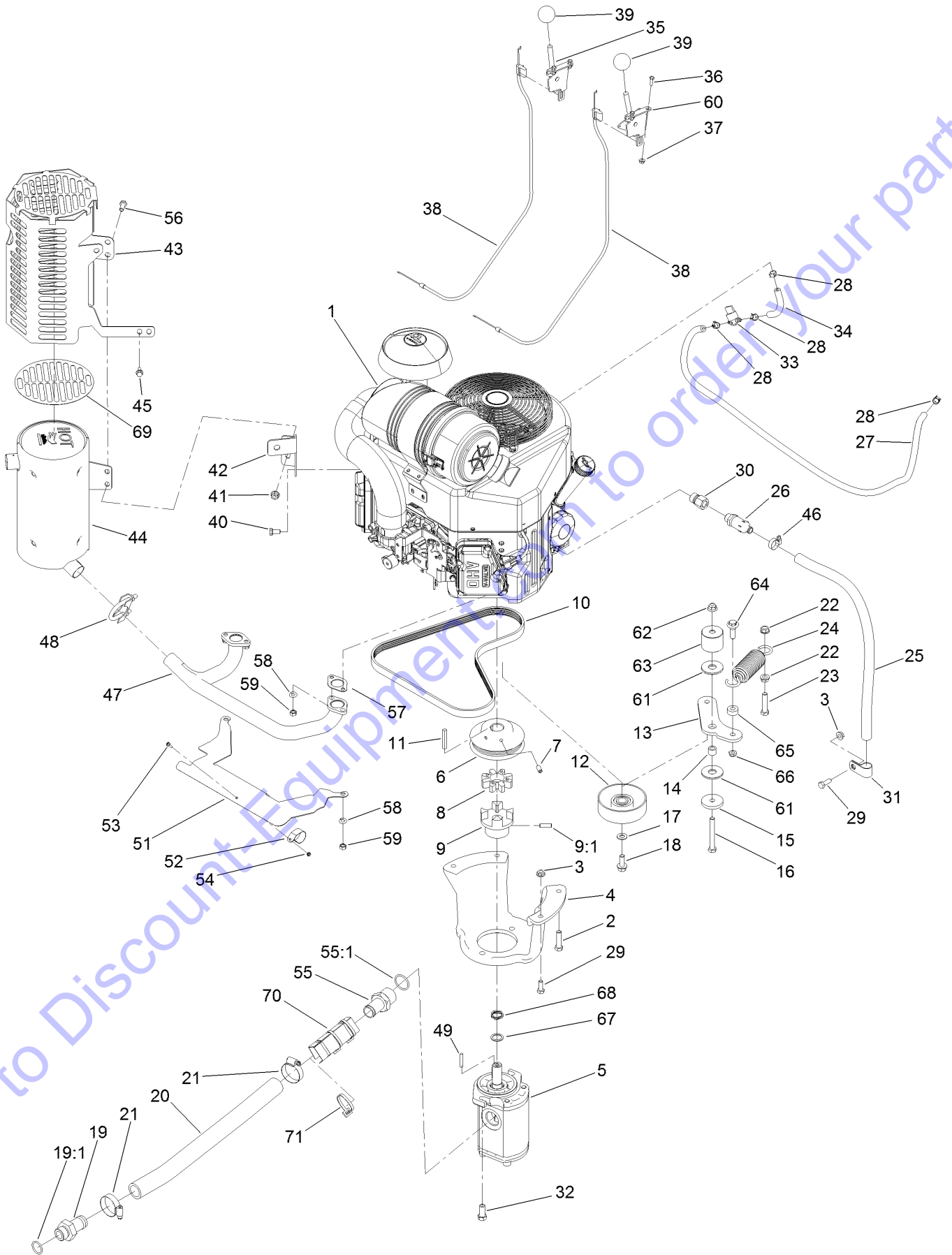

Go to Discount Equipment.com to order your parts

Engine Assembly (continued)

Ref.	Part Number	Qty.	Description	Ref.	Part Number	Qty.	Description
1	133-8077	1	Engine-Kawasaki, Fx730V	36	3290-134	4	Screw
2	323-8	4	Screw-HH	37	32128-17	4	Nut-Lock, Flange
3	32128-20	3	Nut-HF	38	115-1211	2	Cable-Control
4	115-1480-03	1	Mount-Pump	39	233-42	2	Knob
5	117-6444	1	Gear Pump ASM	40	33114-016	2	Screw-HH
6	114-8559-03	1	Pulley-Engine	41	112-2844	3	Nut-HF
7	3246-6	2	Screw-Set, HSH	42	115-9233-03	1	Bracket-Mount, Muffler
8	93-8827	1	Coupler-Spider	43	137-4879-03	1	Guard-Muffler
9	114-2933	1	Coupler-Flex	44	120-7536	1	Muffler
9:1	105-4068	1	Screw-Set, HSH	45	33103-016	1	Screw-HHF
10	114-2991	1	Belt-V	46	2412-36	1	Clamp-Hose
11	608006	1	Key-Square	47	120-7535	1	Manifold, Muffler
12	95-8802	1	Pulley-Idler	48	2112-11	1	Clamp-Muffler
13	125-0252	1	Arm-Idler	49	27-8590	1	Key-Square
14	1-413088	1	Bushing-Lever, Lift	51	115-9227	1	Plate-Shield, Heat
15	110-9981	1	Washer-Plain	52	115-6488	1	Clamp
16	323-14	1	Screw-HH	53	115-6494	1	Screw-Pan
17	3256-24	1	Washer-Flat	54	115-6495	1	Nut-Hex
18	3234-11	1	Screw-HHF	55	354-78	1	Fitting-STR
19	99-3017	1	Fitting	55:1	237-146	1	O-Ring
19:1	237-81	1	O-Ring	56	33114-020	3	Screw-HH
20	114-2917	1	Hose-Suction	57	1-653313	2	Gasket-Exhaust
21	2412-111	2	Clamp-Hose, W/Liner	58	115-6496	4	Washer-Spring
22	3290-357	2	Nut-HSF	59	115-6611	4	Nut-Hex
23	323-9	1	Screw-HH	60	110-5547	1	Lever-Control
24	121-4523	1	Spring-Extension	61	114-0463	2	Washer-Friction, Composite
25	99-1356	1	Hose-Vent	62	104-8301	1	Nut-HF, NI
26	92-6877	1	Valve-Drain, Oil	63	125-0251	1	Spacer-Idler
27	110-3372	1	Hose-Fuel	64	614672	1	Screw-Shoulder, HWH
28	2412-98	4	Clamp-Hose	65	104-8426	1	Spacer
29	322-4	3	Screw-HH	66	3296-59	1	Nut-Lock, NI
30	103-1966	1	Adapter-STR	67	115-7210	1	Washer-Thrust
31	2412-81	1	Clamp-R	68	121-4517	1	Washer-Wave
32	324-4	2	Screw-HH	69	131-0604	1	Guard-Foil
33	1-603770	1	Valve-Fuel	70	AU112950	2	Protector-Hose
34	109-0295	1	Hose-Fuel	71	3290-378	3	Tie-Cable
35	108-9730	1	Lever-Control				

Hydraulic Gear Pump Assembly No. 117-6444

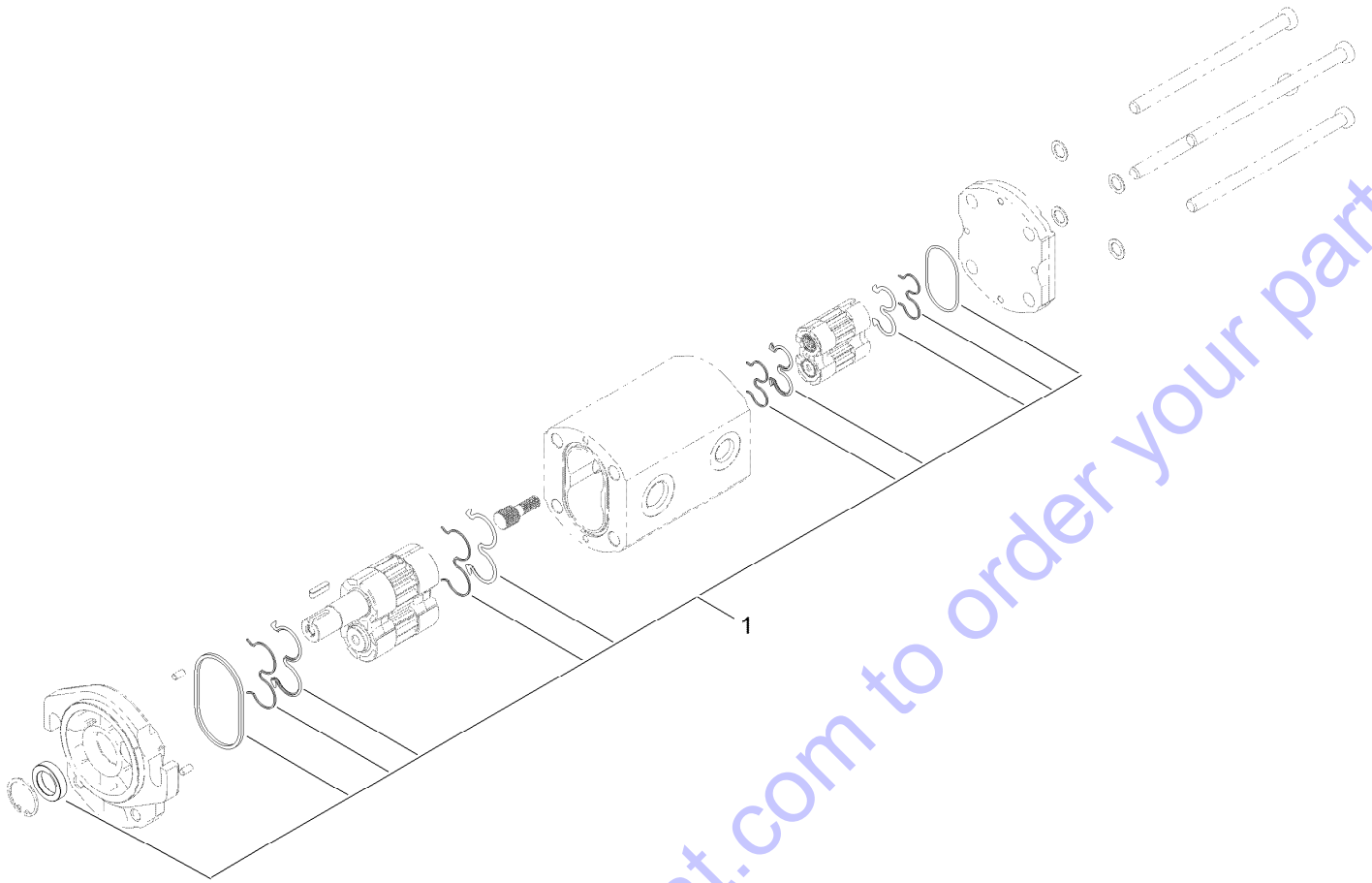

Go to Discount-Equipment.com to order your parts

Hydraulic Gear Pump Assembly No. 117-6444 (continued)

<i>Ref.</i>	<i>Part Number</i>	<i>Qty.</i>	<i>Description</i>
1	138-5210	1	Kit-Seal, Pump

Go to Discount-Equipment.com to order your parts

Control Assembly

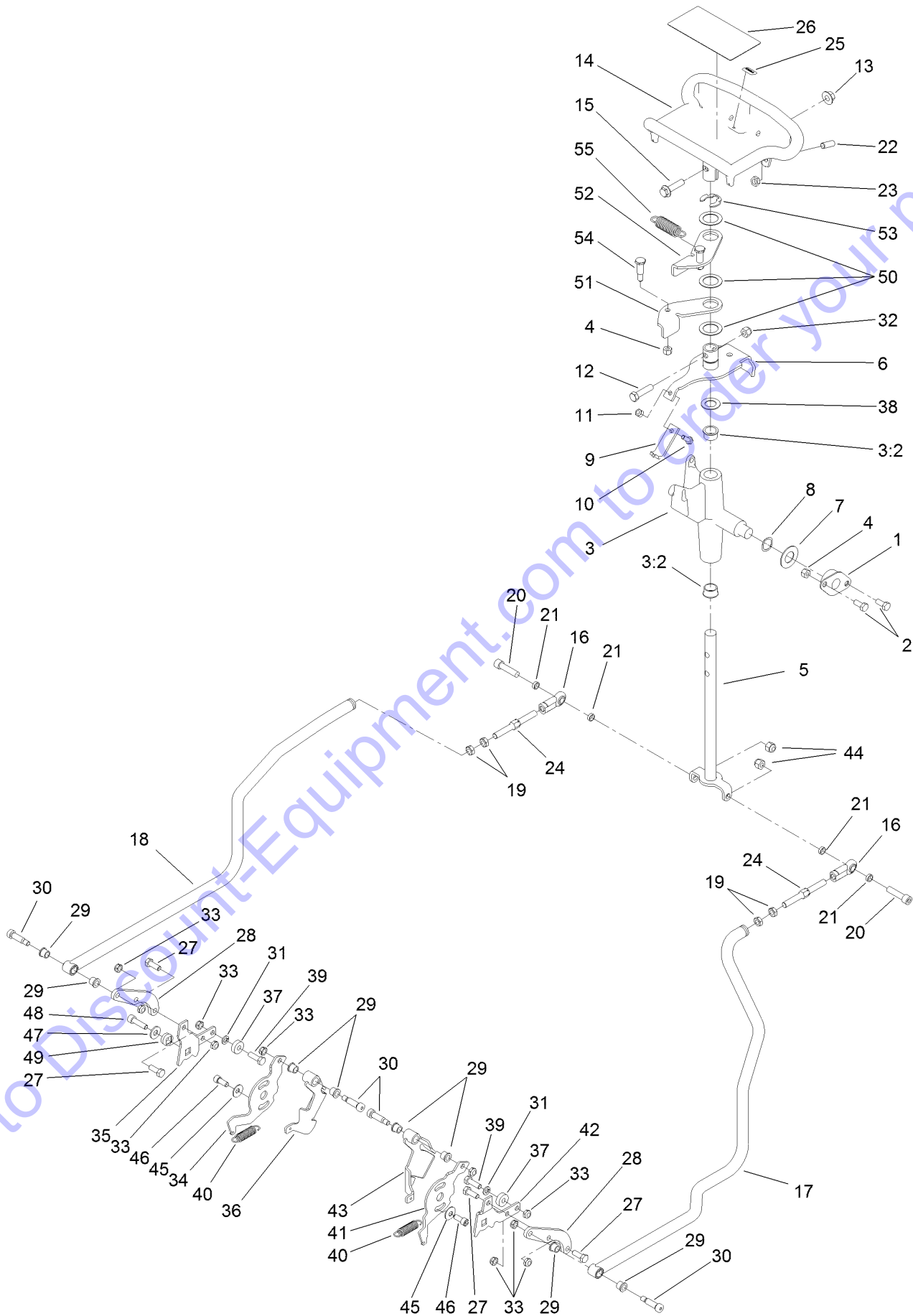

Go to Discount-Equipment.com to order your parts

Control Assembly (continued)

<i>Ref.</i>	<i>Part Number</i>	<i>Qty.</i>	<i>Description</i>	<i>Ref.</i>	<i>Part Number</i>	<i>Qty.</i>	<i>Description</i>
1	27-2320	2	Bearing	28	115-1290	2	Plate-Adapter, Control, RH
2	322-3	4	Screw-HH	29	256-116	8	Bushing-Flange
3	106-5737	1	Control Support ASM	30	114-8629	4	Bolt-Shoulder
3:2	256-252	2	Bearing-Flange	31	3253-4	2	Washer-Lock
4	3296-29	6	Nut-Lock, NI	32	3296-39	1	Nut-Lock, NI
5	117-6335	1	Rod-Drive	33	3296-47	10	Nut-Lock,NI
6	112-2783	1	Lever-Pivot	34	115-6535	1	Plate-Base, RH
7	3256-39	2	Washer-Flat	35	115-6536	1	Plate-Arm, Return
8	95-3703	2	Washer-Spring, Wave	36	115-6636	1	Pivot-RH
9	115-1204	1	Plate-Neutral	37	251-259	2	Bearing-Ball
10	321-4	1	Screw-HH	38	257-8	1	Washer-Thrust
11	3296-42	1	Nut-Lock, NI	39	322-5	2	Screw-HH
12	323-8	1	Screw-HH	40	121-4409	2	Spring-Extension
13	32128-43	1	Nut-Flange	41	115-6549	1	Plate-Base, LH
14	120-5380-03	1	Handle-Control	42	115-6628	1	Plate-Arm, Return, LH
15	3234-18	1	Screw-HHF	43	115-6637	1	Pivot-LH
16	103-1167	2	Joint-Ball End, LH	44	3296-39	2	Nut-Lock, NI
17	121-4511	1	Rod-Control, LH	45	3290-456	2	Washer-Belleville
18	121-4512	1	Rod-Control, RH	46	3273-14	2	Screw-HSH
19	3220-3	4	Nut-HJ	47	3256-3	2	Washer-Flat
20	3274-2	2	Screw-HSH	48	94-3559	2	Screw-HSH
21	108-0634	4	Spacer-Plate, Retaining	49	117-6429	2	Lock-Trunion
22	3247-6	2	Screw-Set	50	108-9743	3	Washer-Plain
23	3218-3	2	Nut-Jam	51	98-8407	1	Lever-Return, RH
24	121-4506	2	Link-Control, Adjustment	52	98-8408	1	Lever-Return, LH
25	98-1459	1	Decal	53	32151-91	1	Ring-Retaining
26	115-4020	1	Decal-Traction	54	63-2650	2	Screw-Shoulder
27	322-4	4	Screw-HH	55	108-4724	1	Spring-Extension

Frame and Cutter Wheel Assembly

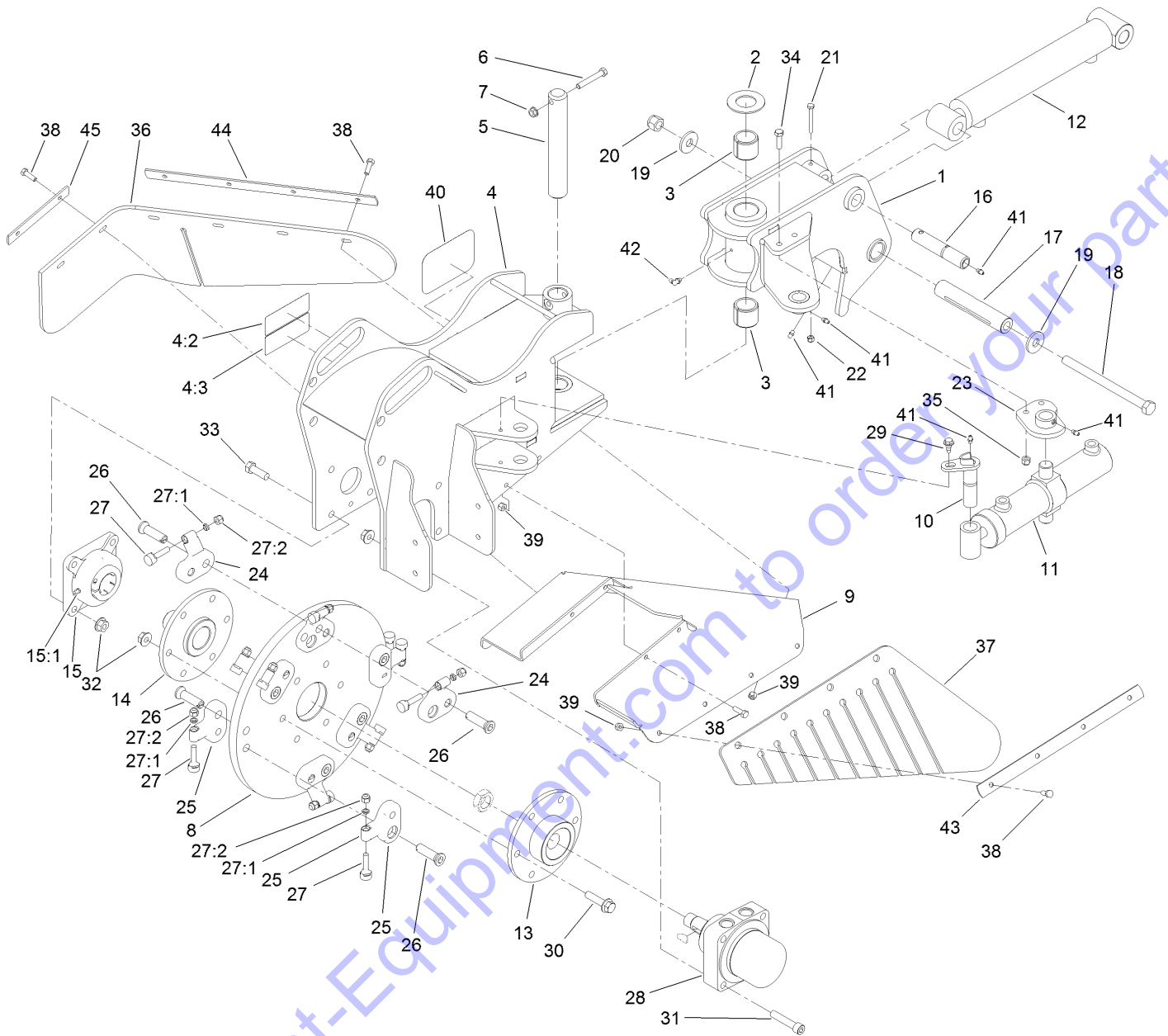

Go to Discount-Equipment.com to order your parts

Frame and Cutter Wheel Assembly (continued)

<i>Ref.</i>	<i>Part Number</i>	<i>Qty.</i>	<i>Description</i>	<i>Ref.</i>	<i>Part Number</i>	<i>Qty.</i>	<i>Description</i>
1	117-6390-01	1	Pivot	23	115-9392-01	1	Mount-Cylinder
2	99-2707	1	Washer	24	115-9384	8	Pocket-Angled
3	99-2713	2	Bushing-Tension	25	115-9388	4	Pocket-Straight
4	119-4612	1	Frame ASM	26	115-9386	12	Bolt-HSH, RH
4:2	107-9366	1	Decal-Warning	27	115-9385	12	Grinder Tooth ASM
4:3	93-7321	1	Decal-Danger	27:1	3296-39	1	Nut-Lock, NI
5	117-6445	1	Pin-Pivot	27:2	121-4365	1	Spacer-Tooth
6	323-47	1	Screw-HH	28	127-9603	1	HYD Motor ASM
7	3290-357	1	Nut-HSF	29	99-5105	1	Screw-Shoulder
8	119-5050-03	1	Wheel-Cutter	30	3234-27	6	Screw-HHF
9	119-5064-03	1	Guard-Chip	31	3274-71	4	Screw-HSH
10	94-9797	1	Pin-Pivot	32	32128-49	14	Nut-HHF
11	117-6441	1	HYD Cylinder ASM	33	325-6	4	Screw-HH
12	121-1955	1	HYD Cylinder ASM	34	323-7	2	Screw-HH
13	119-4570-03	1	Hub-Drive	35	3296-39	2	Nut-Lock, NI
14	115-9395-03	1	Shaft-Stub	36	119-5060	1	Shield-Rubber, RH
15	104-2026	1	Bearing	37	119-5061	1	Shield-Rubber, LH
15:1	302-2	1	Fitting-Grease	38	322-5	14	Screw-HH
16	120-7352	1	Pin-Pivot	39	3296-29	14	Nut-Lock, NI
17	121-4571	1	Spacer-Pivot	40	104-3989	1	Decal
18	117-6327	1	Bolt-HH	41	302-5	5	Fitting-Grease
19	104-9216	2	Washer-Hardened	42	302-40	1	Fitting-Grease, 90 DEG
20	3296-53	1	Nut-Lock, NI	43	119-5118-03	1	Strap-Retainer, LH
21	321-18	1	Screw-HH	44	119-5119-03	1	Strap-Retainer, Rear
22	3296-42	1	Nut-Lock, NI	45	119-5120-03	1	Strap-Retainer, RH

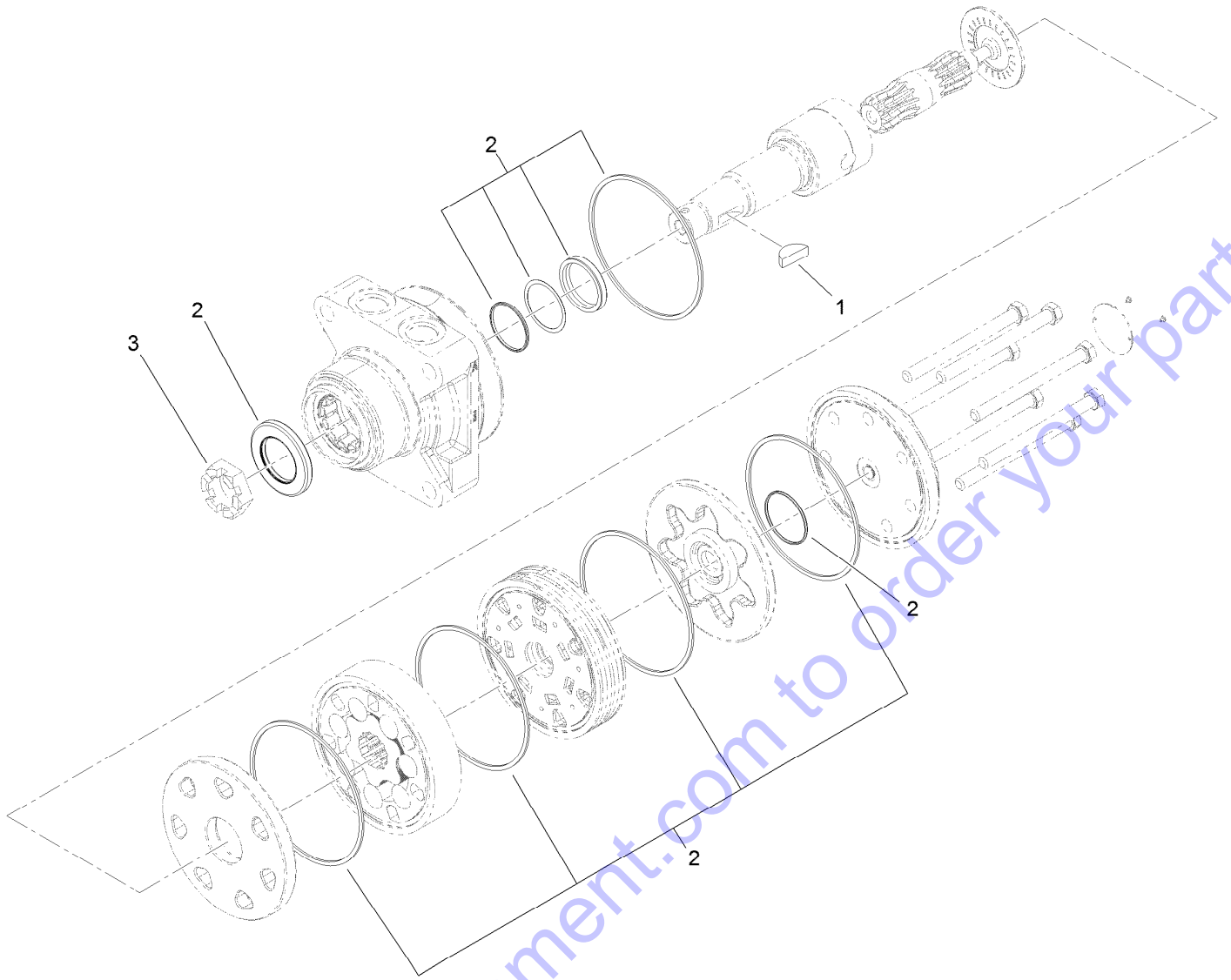

Hydraulic Motor Assembly No. 127-9603

<i>Ref.</i>	<i>Part Number</i>	<i>Qty.</i>	<i>Description</i>
1	3257-42	1	Key-Woodruff
2	119-4631	1	Seal Kit
3	106-8159	1	Nut-Lock

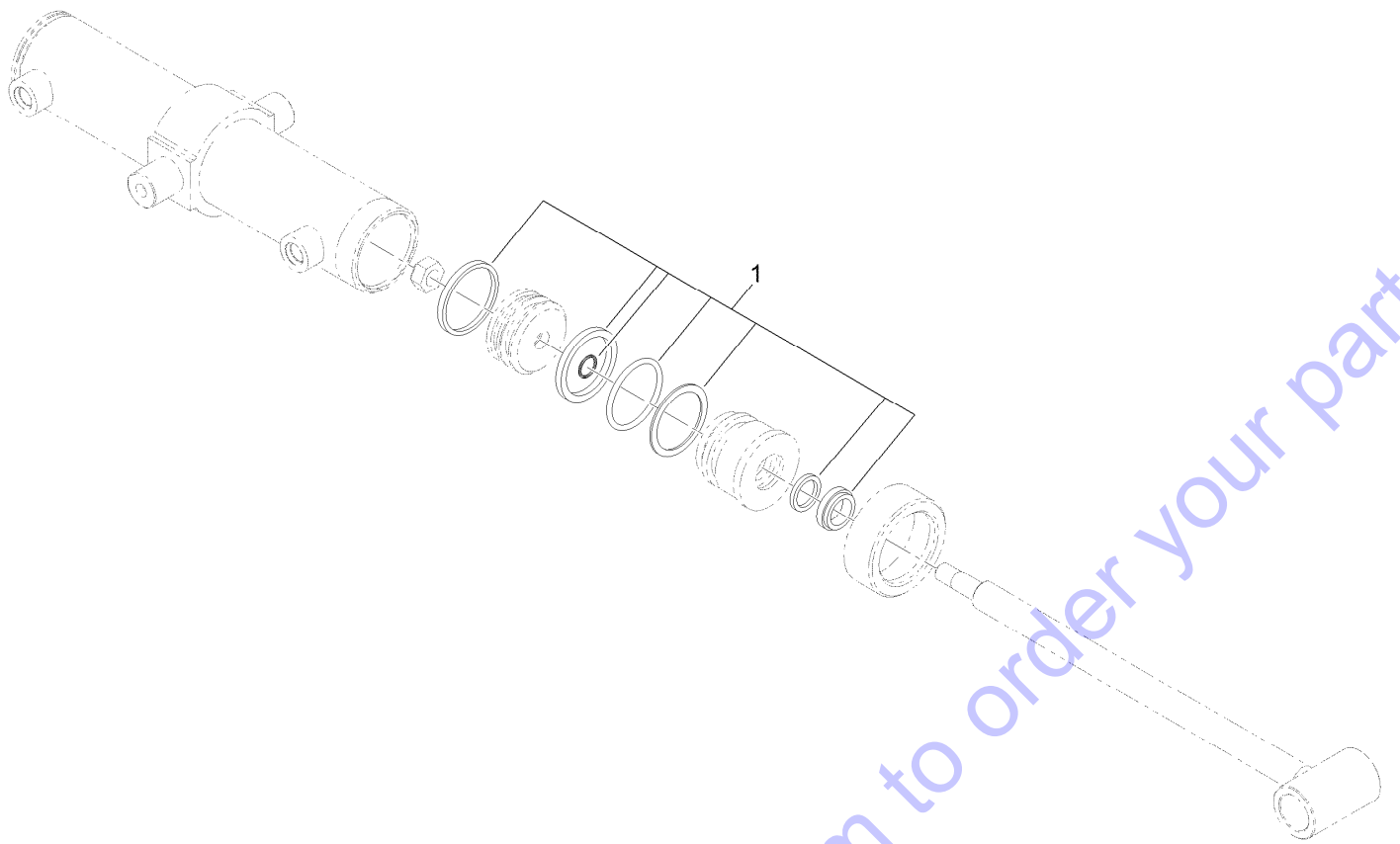

Hydraulic Cylinder Assembly No. 117-6441

<i>Ref.</i>	<i>Part Number</i>	<i>Qty.</i>	<i>Description</i>
1	119-4632	1	Seal Kit

Hydraulic Cylinder Assembly No. 121-1955



Hydraulic Cylinder Assembly No. 121-1955 (continued)

<i>Ref.</i>	<i>Part Number</i>	<i>Qty.</i>	<i>Description</i>
1	131-0665	1	Seal Kit

Go to Discount-Equipment.com to order your parts

Tower and Fuel Tank Assembly

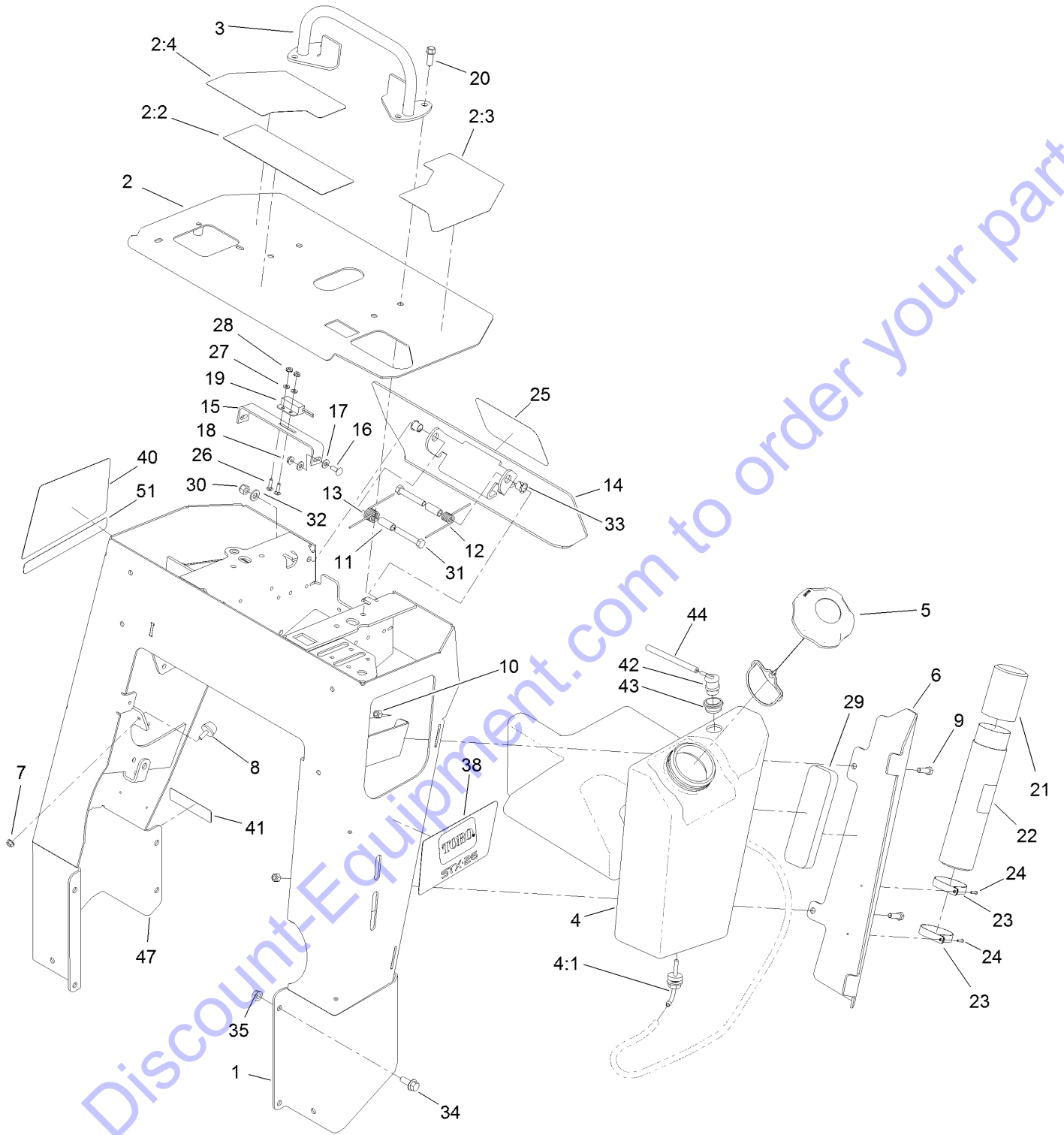

Go to Discount-Equipment.com to order your parts

Tower and Fuel Tank Assembly (continued)

<i>Ref.</i>	<i>Part Number</i>	<i>Qty.</i>	<i>Description</i>	<i>Ref.</i>	<i>Part Number</i>	<i>Qty.</i>	<i>Description</i>
1	119-5100-01	1	Tower	21	104-7048	1	Cap-Housing
2	119-4613	1	Control Panel ASM	22	104-7050	1	Tube-Manual
2:2	119-4606	1	Decal-Warning	23	2412-120	2	Clamp-R
2:3	119-4560	1	Decal-Console, LH	24	3269-17	2	Rivet-Pop
2:4	119-4561	1	Decal-Console, RH	25	105-1217	1	Decal
3	106-7715	1	Bar-Reference	26	3229-20	2	Screw-CARR
4	120-7359	1	Tank-Fuel	27	3256-51	2	Washer-Flat
4:1	103-2605	1	Fitting-Fuel, Bulkhead	28	32149-7	2	Nut-Keps
5	137-4119	1	Cap-Fuel, Ratcheting	29	107-7507	1	Pad-Foam
6	119-5086-01	1	Bracket-Cover, Tank	30	3296-39	2	Nut-Lock, NI
7	32128-33	1	Nut-HF	31	323-11	2	Screw-HH
8	1-523420	1	Bumper	32	3256-24	2	Washer-Flat
9	322-5	2	Screw-HH	33	256-257	2	Bushing-Nyliner
10	3296-29	2	Nut-Lock, NI	34	3234-11	8	Screw-HHF
11	114-1337	2	Spacer-Spring	35	32128-40	8	Nut-Flange
12	98-8425	1	Spring-Torsion, LH	38	119-4563	1	Decal-Side, LH
13	98-8424	1	Spring-Torsion, RH	40	119-4565	1	Decal-Side, RH
14	112-2786-03	1	Plate-Reverse	41	133-8062	1	Decal-Arrestor, Spark
15	100-1263	1	Plate-Switch	42	119-3547	1	Valve-Vent, Fuel
16	3229-1	2	Screw-CARR	43	114-0284	1	Grommet
17	3256-22	4	Washer-Flat	44	117-6395	1	Hose-Vent, Tank
18	32149-2	2	Nut-Keps	47	93-9084	2	Decal-Point, Lift
19	100-1270	1	Switch-Proximity	51	130-7577	1	Decal-Intellisweep
20	95-1726	4	Screw-Taptite				

Go to Discount-Equipment.com to Order your parts

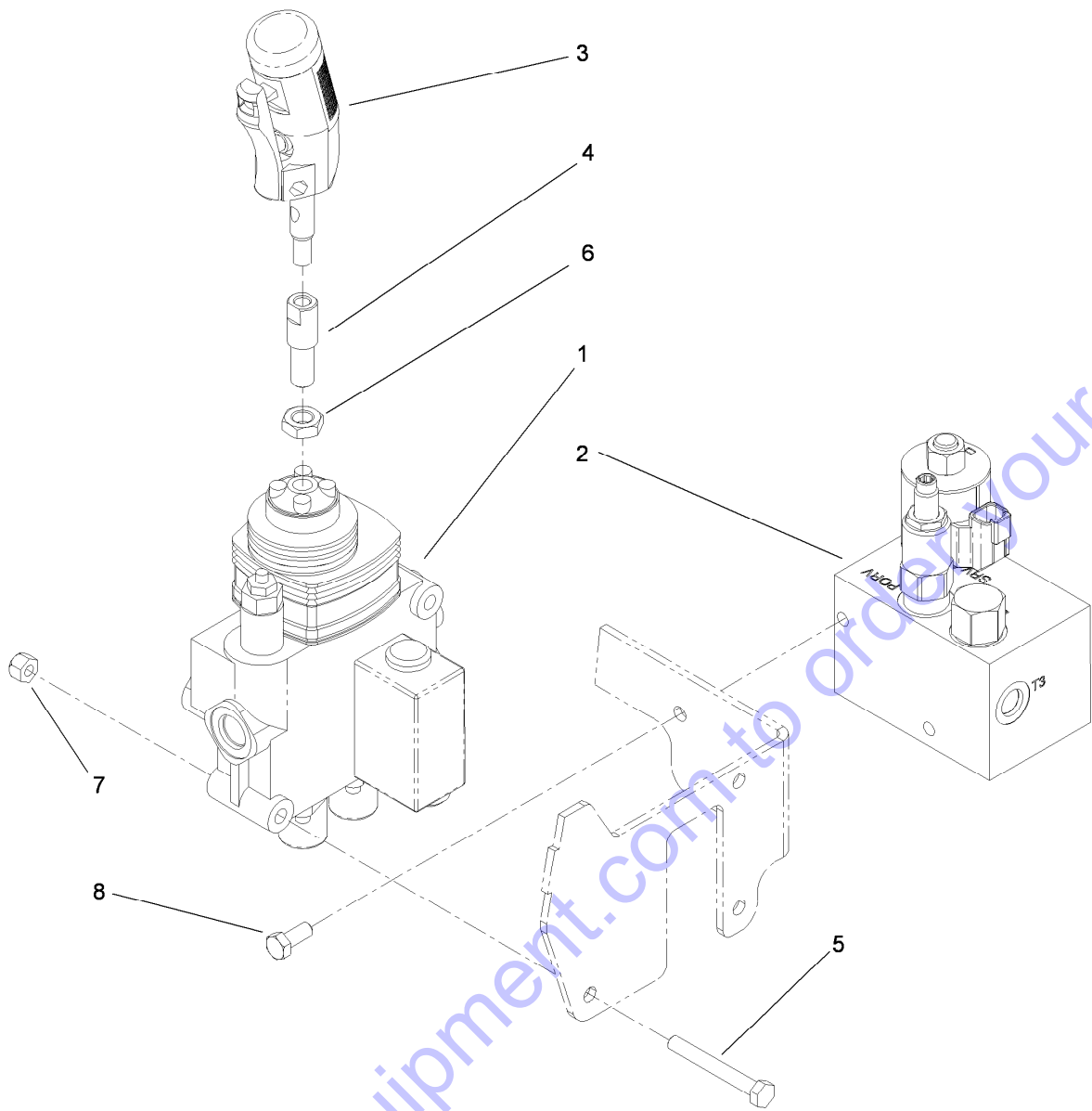

Control Valve Assembly

Ref.	Part Number	Qty.	Description
1	119-4585	1	HYD Valve ASM
2	119-4586	1	Cutter Wheel Valve ASM
3	119-4587	1	Two Button Handle Grip ASM
4	119-5103	1	Adapter-Handle
5	322-12	3	Screw-HH
6	51-2070	1	Nut
7	3296-29	3	Nut-Lock, NI
8	322-3	2	Screw-HH

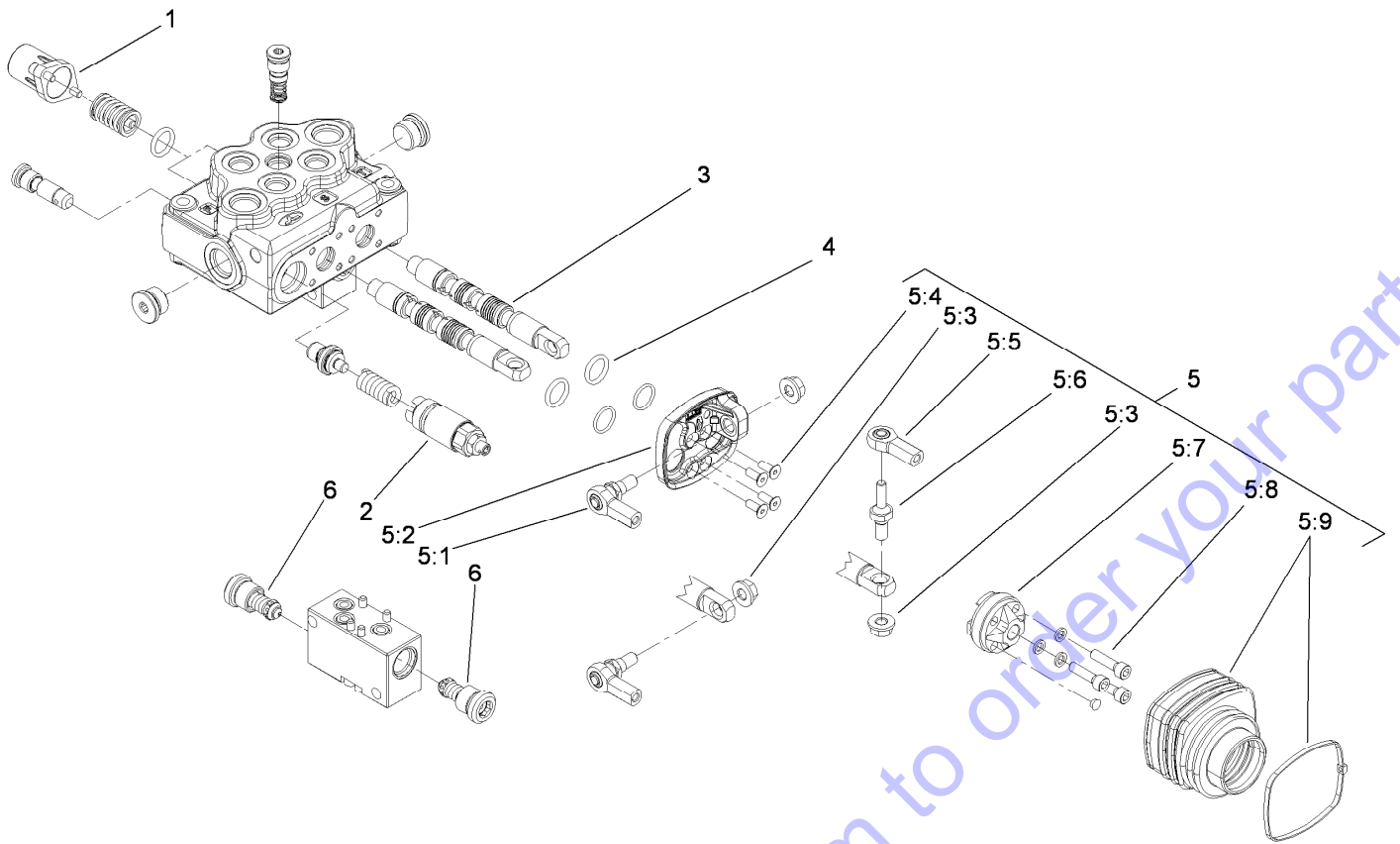

Control Valve Assembly No. 119-4585

Ref.	Part Number	Qty.	Description
1	100-8801	2	High Force Spring Kit
2	100-8805	1	Valve-Relief
3	114-8625	2	Valve-Spool
4	106-7719	4	Seal-Valve
5	119-4622	1	Joystick Kit
5:1	119-4623	2	Joint-Joystick
5:2	119-4624	1	Base-Joystick
5:3	117-1350	3	Nut-HF, Lock
5:4	119-4625	4	Screw-Joystick
5:5	119-4626	1	Joint-Joystick
5:6	119-4627	1	Pin-Spool
5:7	119-4628	1	Holder-Joystick
5:8	3273-42	3	Screw-HSH
5:9	119-4629	1	Boot-Joystick
6	119-4630	2	Valve Kit

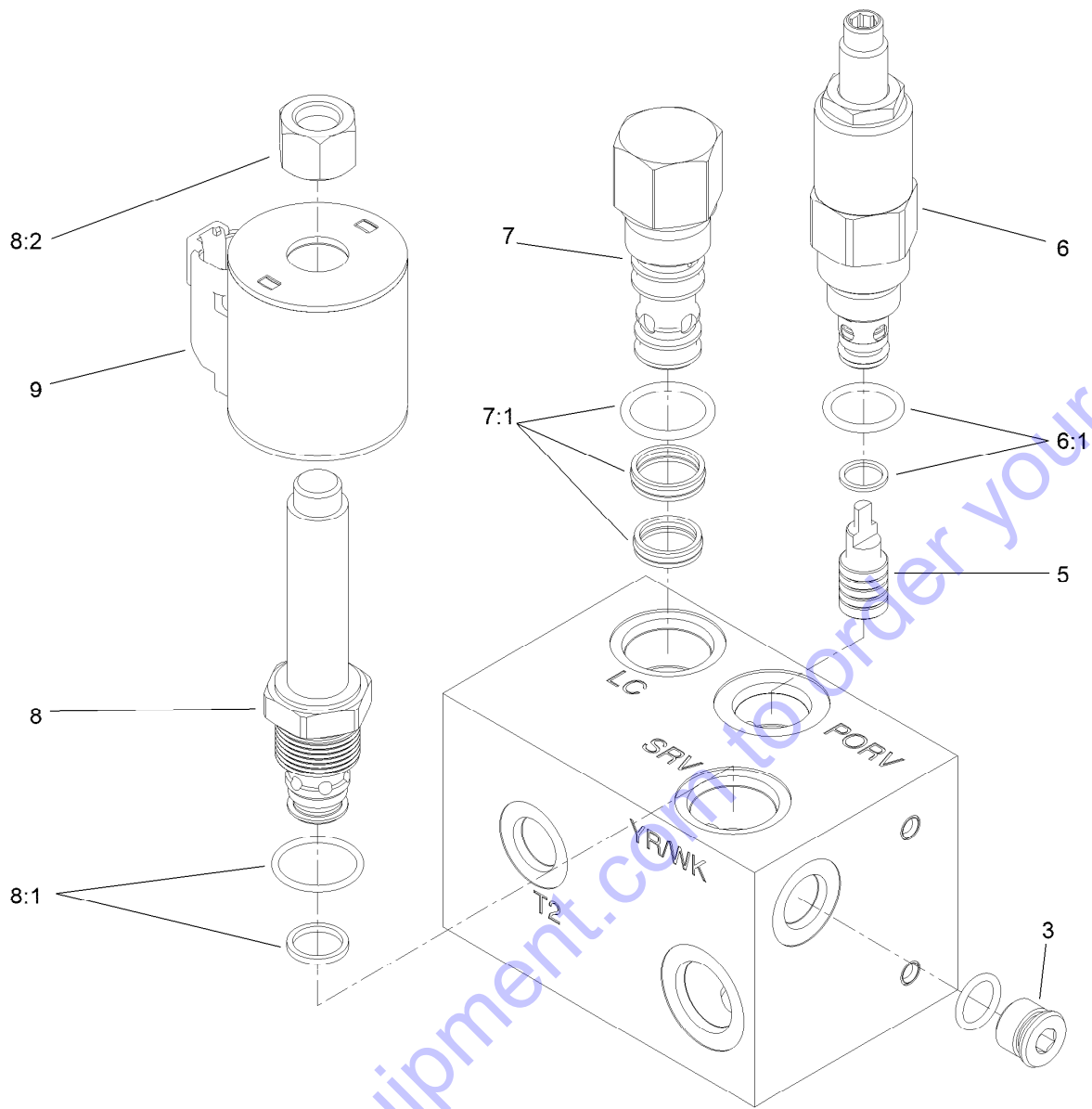

Cutter Wheel Valve Assembly No. 119-4586

Ref.	Part Number	Qty.	Description
3	106-1026	1	Plug-HYD
5	105-9157	1	Piston-Pilot
6	119-4620	1	Valve-Relief
6:1	105-9156	1	Seal Kit
7	105-9153	1	Element-Logic, Vented
7:1	119-2159	1	Seal Kit ●
8	130-7609	1	Valve-Relief,
8:1	110-6316	1	Seal Kit
8:2	130-8180	1	Nut-Coil (9/16-24 Unef-2B)
9	119-4619	1	Coil-Solenoid

● Not illustrated

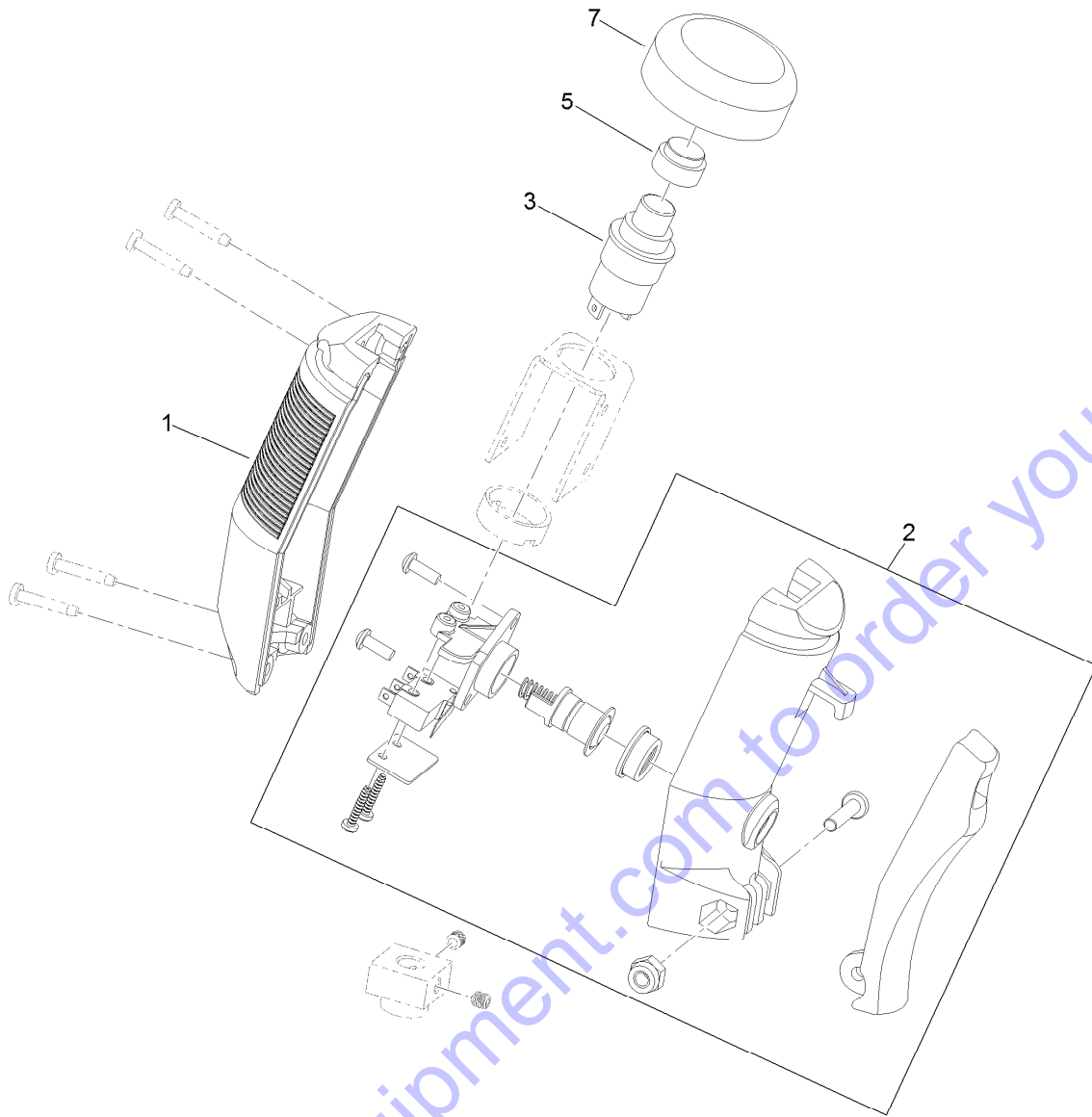

Two-Button Handle Grip Assembly No. 119-4587

Ref.	Part Number	Qty.	Description
1	119-4637	1	Halve-Handle
2	132-8660	1	Swich Kit
3	119-4640	1	Button-Push, Top
5	119-4642	1	Button-Actuator
7	119-4641	1	Boot-Button

Oil Cooler Assembly

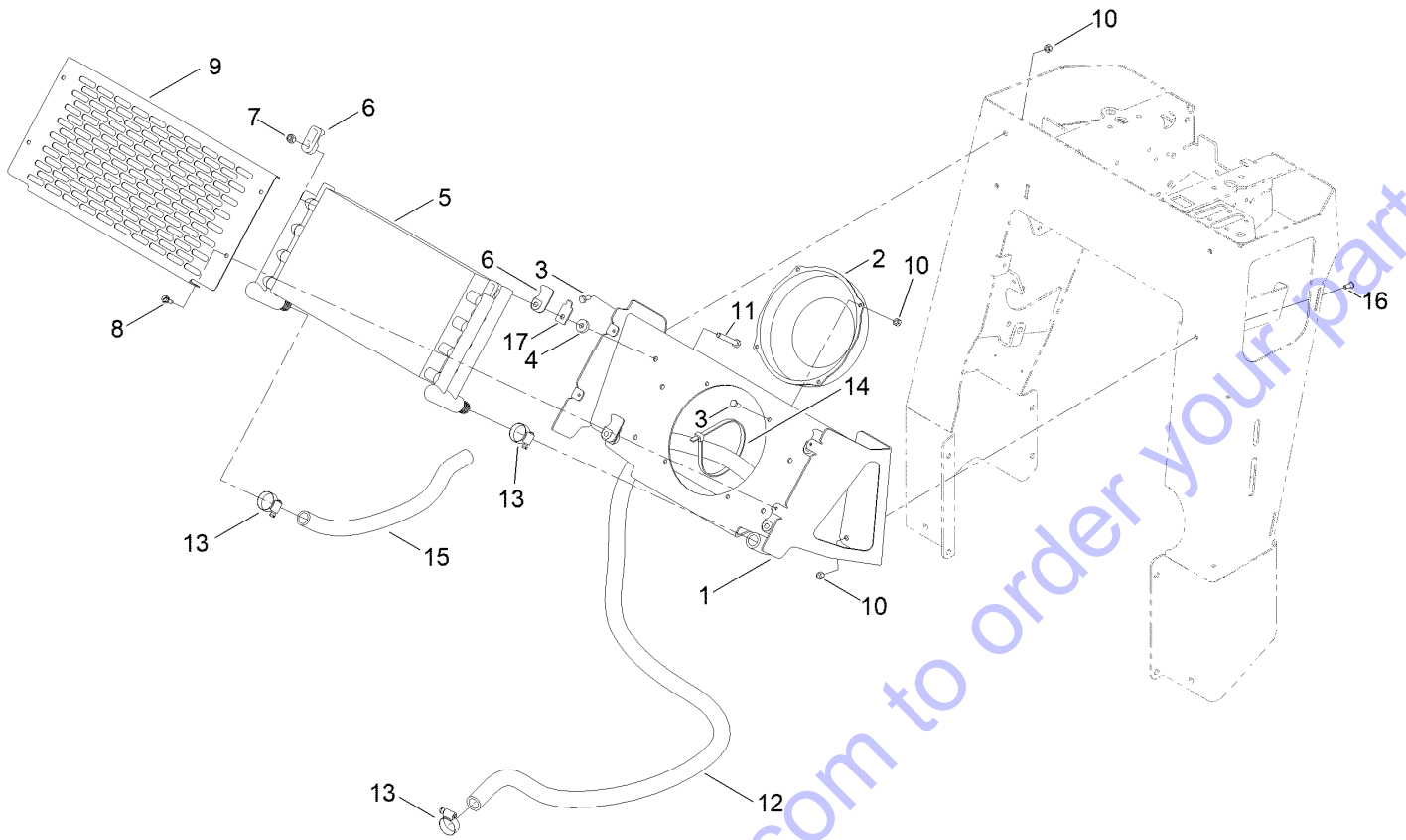

Go to Discount-Equipment.com to order your parts

Oil Cooler Assembly (continued)

<i>Ref.</i>	<i>Part Number</i>	<i>Qty.</i>	<i>Description</i>	<i>Ref.</i>	<i>Part Number</i>	<i>Qty.</i>	<i>Description</i>
1	117-6296-01	1	Mount-Cooler	10	3296-42	8	Nut-Lock, NI
2	104-2809	1	Fan	11	322-11	4	Screw-HH
3	321-3	7	Screw-HH	12	119-4607	1	Hose-Return
4	26-4840	4	Spacer-Pin, Mounting	13	2412-129	3	Clamp-Hose
5	117-6320	1	Cooler-Oil	14	3334-945	1	Tie-Cable
6	131-0733	8	Clamp	15	119-4571	1	Hose-Return
7	3296-29	4	Nut-Lock, NI	16	3274-31	1	Screw-HSBH
8	32104-95	4	Screw-HWH	17	131-0642	4	Plate-Support, Clamp
9	119-4633-01	1	Cover-Cooler				

Go to Discount-Equipment.com to order your parts

Hydraulic Hose Routing Assembly

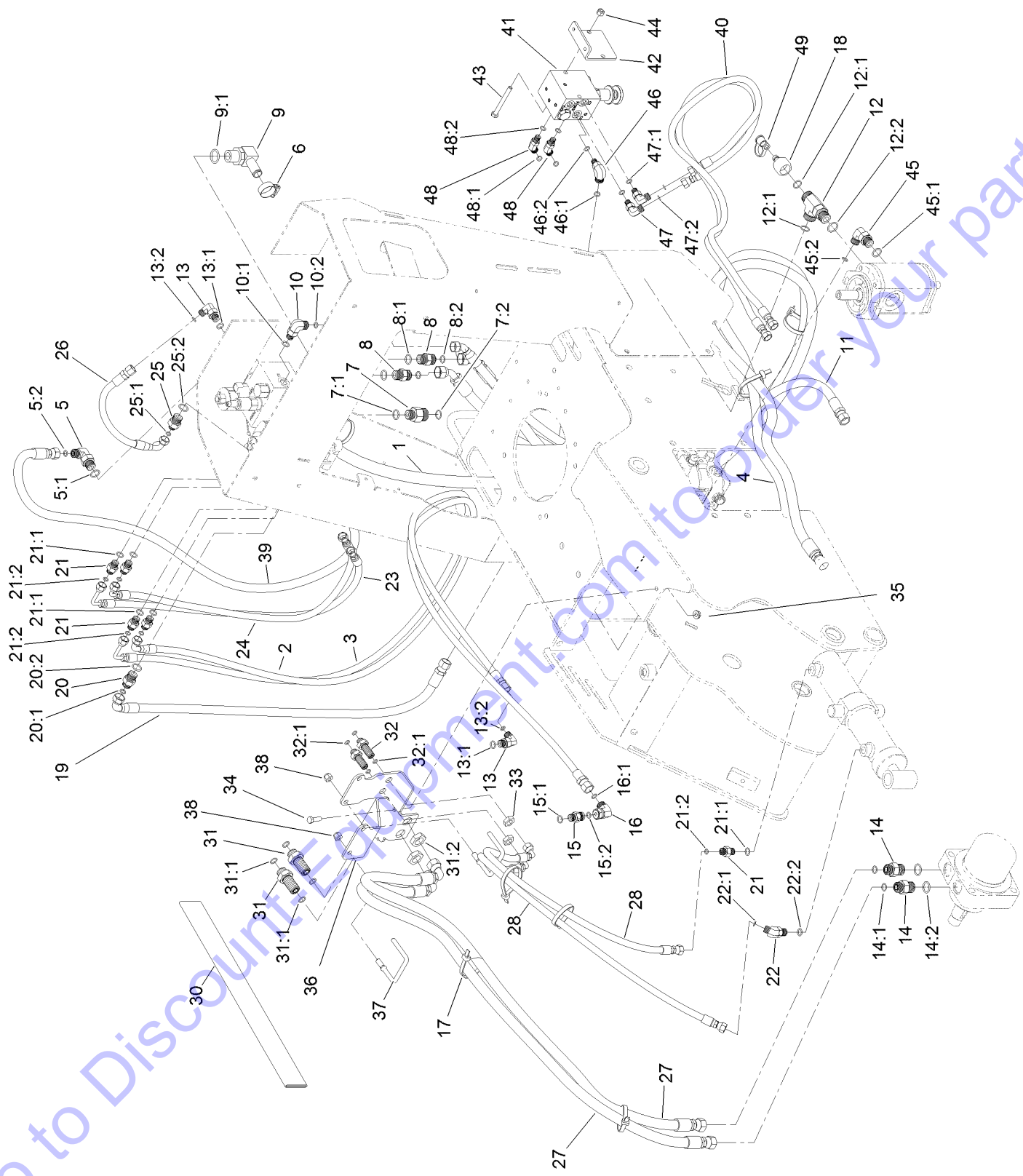

Go to DiscountEquipment.com to order your parts

Hydraulic Hose Routing Assembly (continued)

<i>Ref.</i>	<i>Part Number</i>	<i>Qty.</i>	<i>Description</i>	<i>Ref.</i>	<i>Part Number</i>	<i>Qty.</i>	<i>Description</i>
1	119-4589	1	Hose-HYD	22	340-137	1	Fitting
2	119-4590	1	Hose-HYD	22:1	237-21	1	O-Ring
3	119-4601	1	Hose-HYD	22:2	237-42	1	O-Ring
4	144-7457	2	Hose ASM-HYD	23	130-7602	1	Hose-HYD
5	340-18	1	Fitting-HYD, 90 DEG	24	130-7603	1	Hose-HYD
5:1	237-79	1	O-Ring	25	340-133	1	Fitting-STR
5:2	237-22	1	O-Ring	25:1	237-79	1	O-Ring
6	2412-129	1	Clamp-Hose	25:2	237-21	1	O-Ring
7	340-155	1	Fitting-Straight	26	119-4594	1	Hose-HYD
7:1	237-79	1	O-Ring	27	144-7458	2	Hose ASM-HYD
7:2	237-151	1	O-Ring	28	144-7459	2	Hose ASM-HYD
8	340-4	2	Fitting-Straight	30	99-5648	1	Sleeve-Protective
8:1	237-30	1	O-Ring	31	340-161	2	Fitting-Bulkhead
8:2	237-79	1	O-Ring	31:1	237-30	2	O-Ring
9	353-987	1	Fitting-Elbow, 90	31:2	340-127	1	Nut-Bulkhead
9:1	237-81	1	O-Ring	32	94-1444	2	Union-Bulkhead
10	340-77	1	Fitting-Elbow, 90 DEG	32:1	237-21	2	O-Ring
10:1	237-22	1	O-Ring	33	340-78	2	Nut-Lock
10:2	237-42	1	O-Ring	34	322-5	1	Screw-HH
11	119-4602	1	Hose-HYD	35	32128-20	1	Nut-HF
12	340-22	1	Fitting-Tee	36	125-0263-03	1	Bracket-Bulkhead
12:1	237-65	2	O-Ring	37	121-4555	2	Guide-Hose
12:2	237-80	1	O-Ring	38	3296-39	2	Nut-Lock, NI
13	340-82	2	Fitting-Elbow, 90 DEG	39	130-7604	1	Hose-HYD
13:1	237-42	1	O-Ring	40	130-7605	2	Hose-HYD
13:2	237-21	1	O-Ring	41	121-4466	1	Sweep Manifold ASM
14	340-6	2	Fitting-Straight	42	130-1014-03	1	Bracket-Valve
14:1	237-30	1	O-Ring	43	322-14	2	Screw-HH
14:2	237-80	1	O-Ring	44	3296-29	2	Nut-Lock, NI
15	115-4081	1	Valve-Check	45	340-18	1	Fitting-HYD, 90 DEG
15:1	237-42	1	O-Ring	45:1	237-79	1	O-Ring
15:2	237-22	1	O-Ring	45:2	237-22	1	O-Ring
16	340-159	1	Elbow-90	46	340-97	1	Fitting-Elbow, 90 DEG
16:1	237-22	2	O-Ring	46:1	237-22	1	O-Ring
17	3334-945	13	Tie-Cable	46:2	237-78	1	O-Ring
18	86-5860	1	Nipple	47	340-132	2	Fitting-Elbow, 90 DEG
19	119-4592	1	Hose-HYD	47:1	237-78	1	O-Ring
20	340-3	1	Fitting-Straight	47:2	237-21	1	O-Ring
20:1	237-22	1	O-Ring	48	340-103	2	Fitting-HYD, 45 DEG
20:2	237-79	1	O-Ring	48:1	237-78	1	O-Ring
21	340-1	5	Fitting-Straight	48:2	237-21	1	O-Ring
21:1	237-21	1	O-Ring	49	354-79	1	Cap-Dust
21:2	237-42	1	O-Ring				

Battery and Electrical Assembly

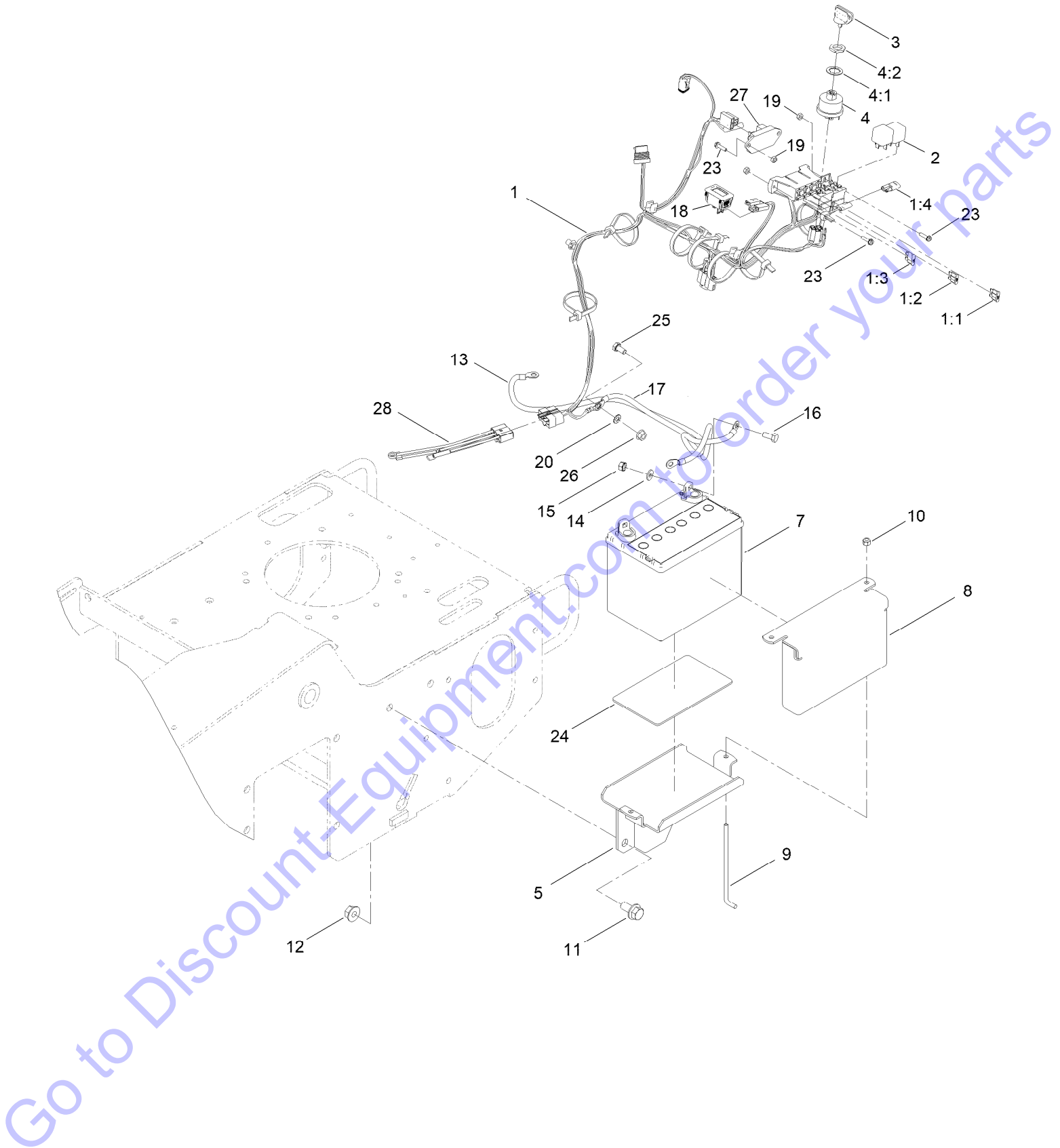

Battery and Electrical Assembly (continued)

<i>Ref.</i>	<i>Part Number</i>	<i>Qty.</i>	<i>Description</i>	<i>Ref.</i>	<i>Part Number</i>	<i>Qty.</i>	<i>Description</i>
1	119-4555	1	Harness-Wire	12	32128-49	2	Nut-HHF
1:1	109103	1	Fuse-Blade, 30 Amp	13	106-8945	1	Cable-Battery, Positive
1:2	109102	1	Fuse-Blade, 25 Amp	14	3256-2	2	Washer-Flat
1:3	109101	1	Fuse-Blade, 20 Amp	15	32149-1	2	Nut-Keps
1:4	116-0053	1	Cap-Plug	16	322-3	2	Screw-HH
2	98-7249	2	Relay	17	117-6422	1	Cable-Battery, Black
3	63-8360	1	Key-Ignition	18	120-2244	1	Hourmeter
4	88-9830	1	Key Switch ASM	19	3296-2	5	Nut-Lock, NI
4:1	3254-5	1	Washer-Lock	20	3255-8	1	Washer-Lock
4:2	218-461	1	Nut-HH	23	32105-13	5	Screw-HWH
5	105-3150-01	1	Tray-Battery	24	62-4300	1	Pad-Skid, Anti
7	99-7421	1	Battery	25	33114-016	1	Screw-HH
8	115-6621-03	1	Plate-Hold Down, Battery	26	33004-00	1	Nut-HF
9	104-8567	2	Holdown-Battery	27	100-6170	1	Module-Delay
10	3296-42	2	Nut-Lock, NI	28	119-4604	1	Harness
11	3234-6	2	Screw-HHF				

Go to Discount-Equipment.com to order your parts

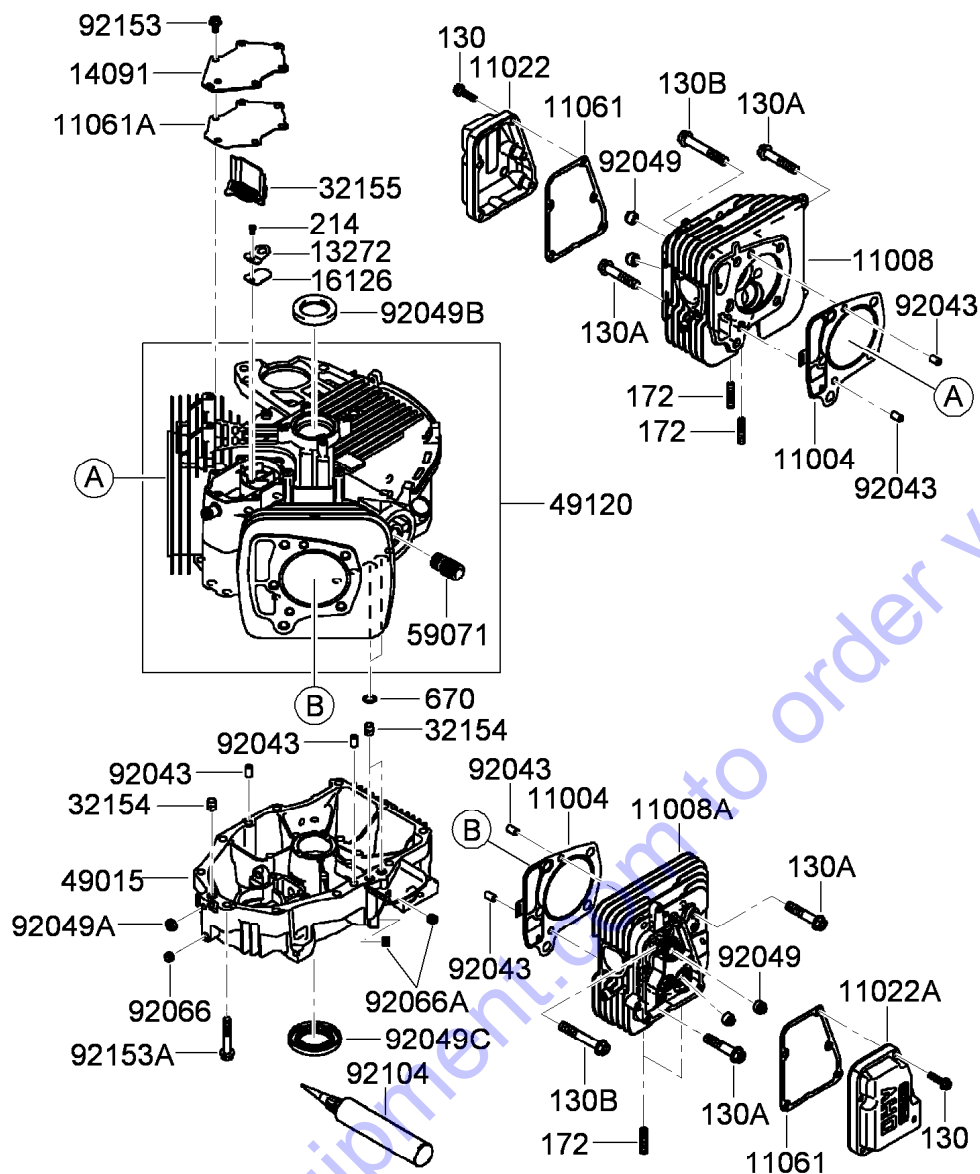

Cylinder and Crankcase Assembly

Ref.	Part Number	Qty.	Description	Ref.	Part Number	Qty.	Description
130	93-8548	10	Bolt-Flanged (6X25)	32154	119-5811	3	Pipe
130A	119-5822	4	Bolt-Flanged (10X50)	32155	119-5812	1	Pipe-Breather
130B	119-5823	6	Bolt-Flanged (10X65)	49015	119-5813	1	Cover-Crankcase
172	114-8658	4	Bolt-Stud (8X18)	49120	119-5814	1	Crankcase ASM
214	115-6422	1	Screw-Pan (4X8)	59071	95-9715	1	Joint
670	95-9771	2	O-Ring (11Mm)	92043	KW10694	6	Pin
11004	119-5800	2	Gasket-Head	92049	114-8650	4	Seal-Oil, Rv C2 (6X11X10.2)
11008	119-5801	1	Head-Cylinder (No.1)	92049A	119-5816	1	Seal-Oil, So (8X14X5) Hs
11008A	119-5802	1	Head-Cylinder (No.2)	92049B	119-5817	1	Seal-Oil, Sd (35X48X8) R Hs
11022	119-5803	1	Case-Rocker (No.1)	92049C	119-5818	1	Seal-Oil (38X62X8) Mtclv
11022A	119-5804	1	Case-Rocker (No.2)	92066	119-5819	1	Plug
11061	119-5805	2	Gasket-Case, Rocker	92066A	119-5820	2	Plug
11061A	119-5806	1	Gasket-Breather	92104	119-5821	1	Gasket-Liquid (Tb1217H)
13272	119-5808	1	Plate-Breather	92153	114-8655	6	Bolt (6X12)
14091	119-5809	1	Cover-Breather	92153A	114-8656	10	Bolt (8X50)
16126	119-5810	1	Valve-Breather				

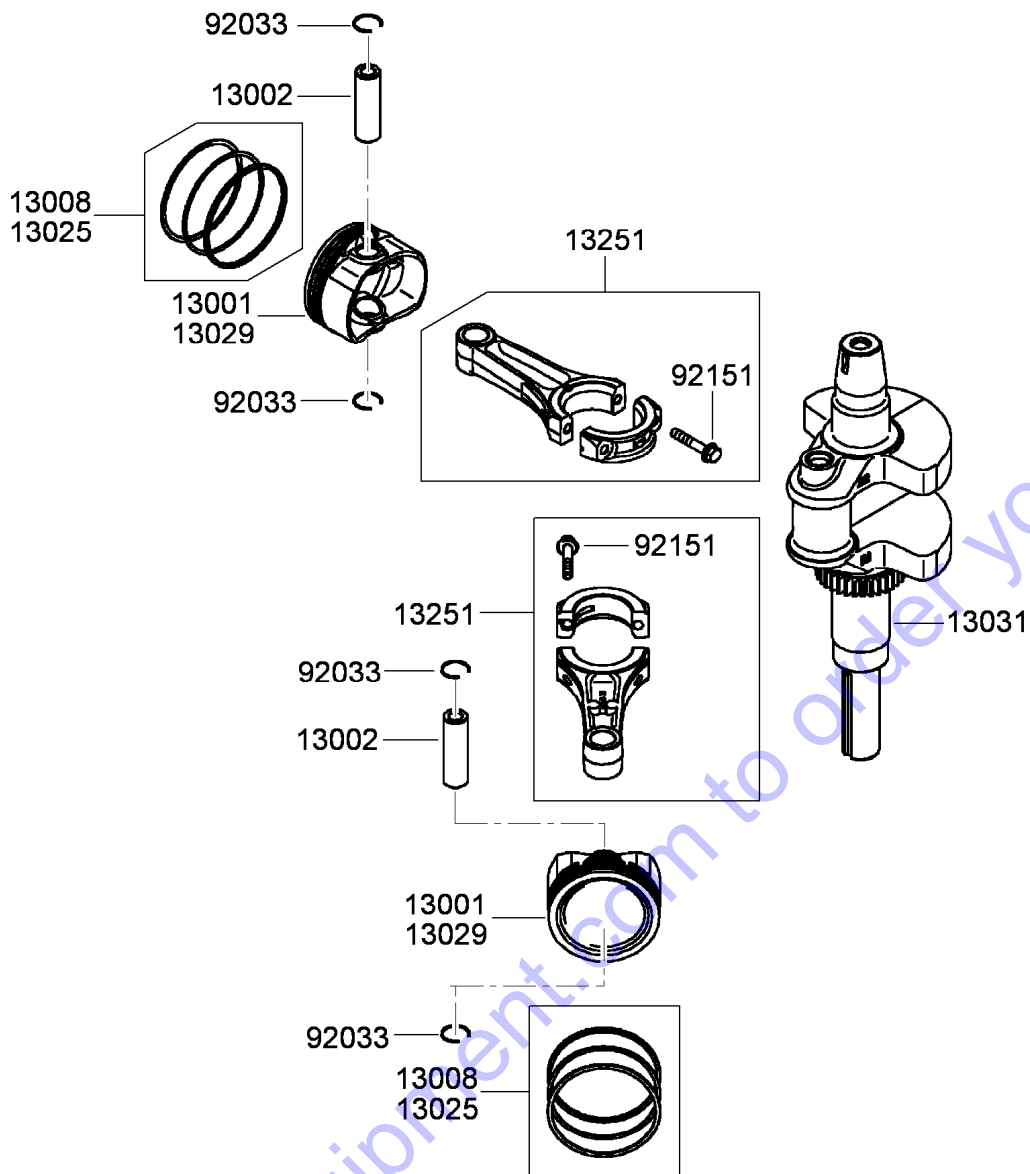

Piston and Crankshaft Assembly

Ref.	Part Number	Qty.	Description
13001	119-5824	2	Piston-Engine
13002	119-5825	2	Pin-Piston
13008	119-5826	2	Piston Ring Set
13025	119-5827	1	Piston Ring Set, L (0.5)
13029	119-5828	1	Piston-Engine, L (0.5)
13031	119-5829	1	Crankshaft ASM
13251	119-5830	2	Connecting Rod ASM
92033	119-5831	4	Ring-Snap
92151	115-6565	4	Bolt (6X35)

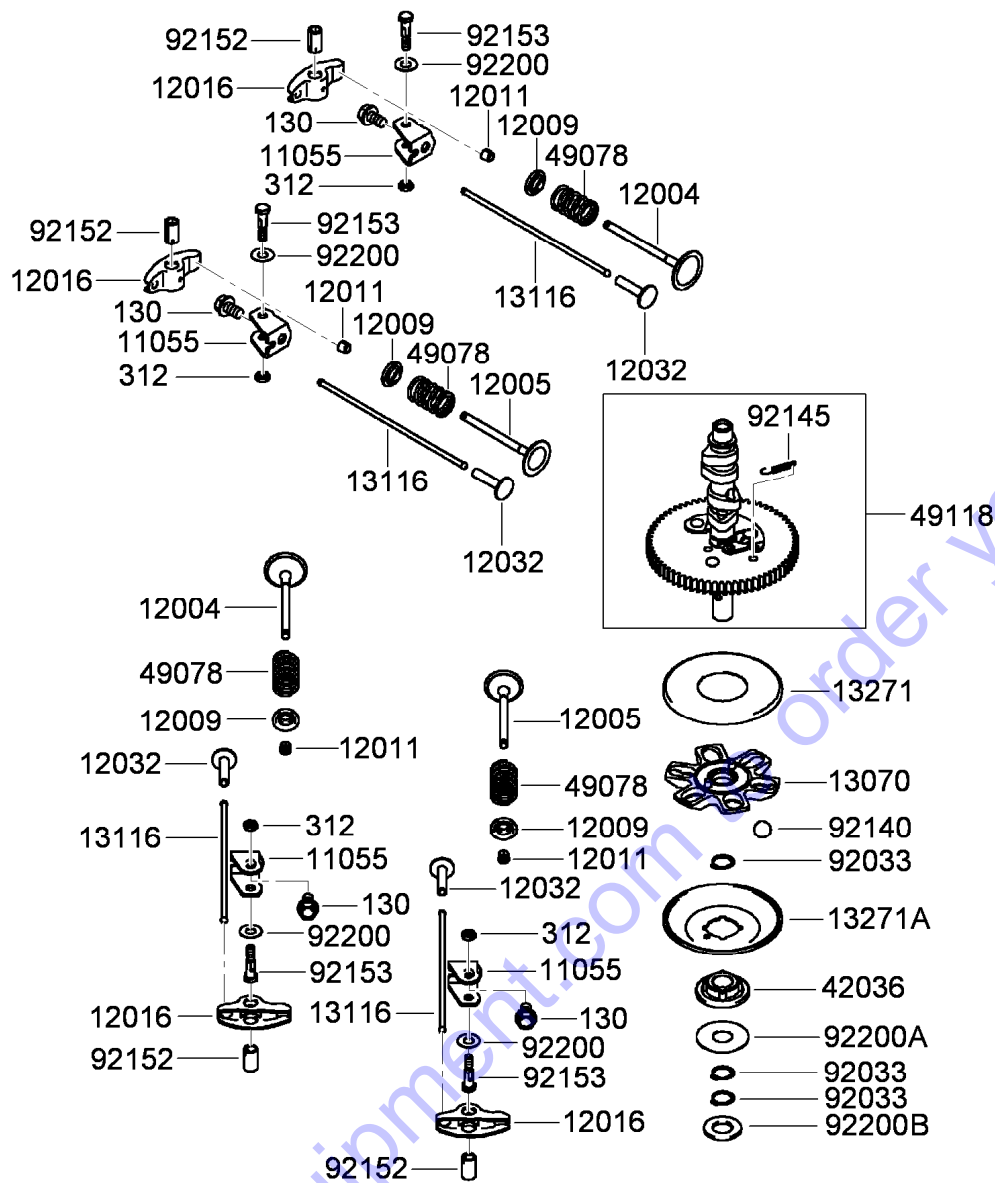

Valve and Camshaft Assembly

<i>Ref.</i>	<i>Part Number</i>	<i>Qty.</i>	<i>Description</i>	<i>Ref.</i>	<i>Part Number</i>	<i>Qty.</i>	<i>Description</i>
130	119-5845	4	Bolt-Flanged (8X14)	13271A	114-8672	1	Plate-Governor
312	119-5846	4	Nut-Hex (6MM)	42036	114-8673	1	Sleeve
11055	119-5832	4	Bracket	49078	119-5838	4	Spring-Valve, Engine (In)
12004	119-5833	2	Valve-Intake	49118	119-5839	1	Camshaft ASM
12005	119-5834	2	Valve-Exhaust	92033	114-8675	3	Ring-Snap
12009	108-2525	4	Retainer-Spring, Valve	92140	114-8676	6	Ball
12011	95-9744	8	Collet	92145	114-8677	1	Spring
12016	119-5835	4	Arm-Rocker	92152	119-5840	4	Collar
12032	108-2527	4	Tappet	92153	119-5841	4	Bolt (6X29.5)
13070	119-5836	1	Guide-Governor	92200	119-5842	4	Washer (8.1X18X0.5)
13116	119-5837	4	Rod-Push	92200A	119-5843	1	Washer (16X42X0.91)
13271	114-8671	1	Plate	92200B	119-5844	1	Washer (16.3X30X2.28)

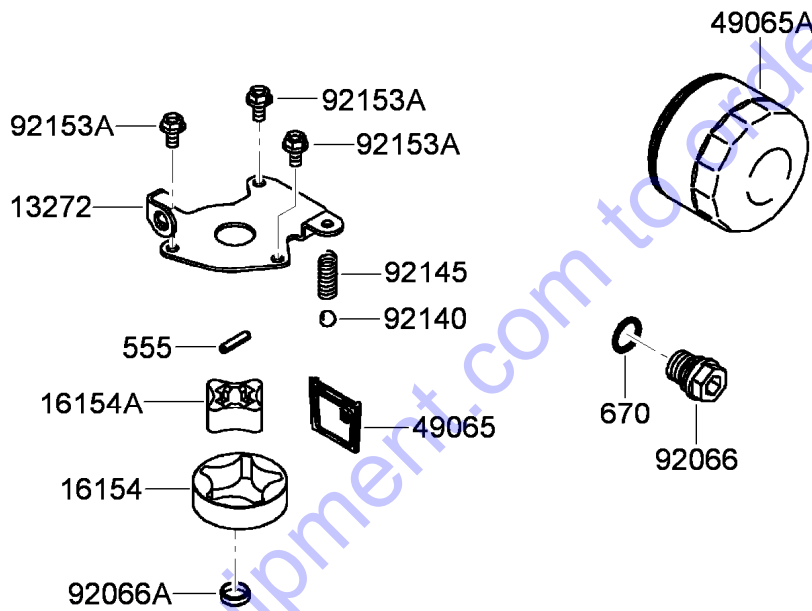
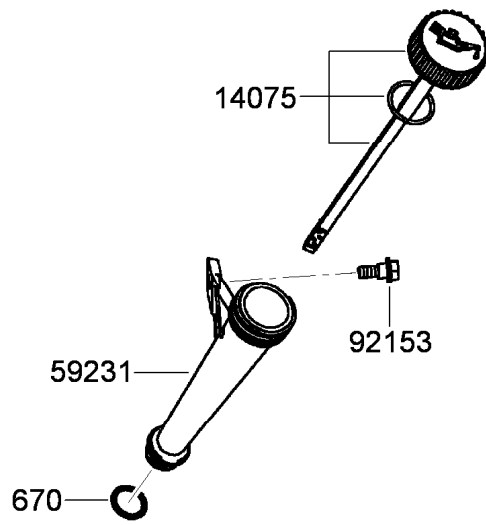

Lubrication Equipment Assembly

Ref.	Part Number	Qty.	Description
555	119-5859	1	Pin-Spring (4X20)
670	1-413506	2	Discontinued
13272	119-5847	1	Plate-Rotor
14075	119-5848	1	Oil Gauge Cap ASM
16154	119-5849	1	Rotor-Pump, Outer
16154A	119-5850	1	Rotor-Pump, Inner
49065	119-5851	1	Filter-Oil
49065A	119-5852	1	Filter-Oil
59231	119-5853	1	Tube-Filler, Oil
92066	119-5854	1	Plug
92066A	119-5855	1	Plug
92140	119-5856	1	Ball
92145	119-5857	1	Spring
92153	119-5858	1	Bolt
92153A	115-6419	3	Bolt (6X12)

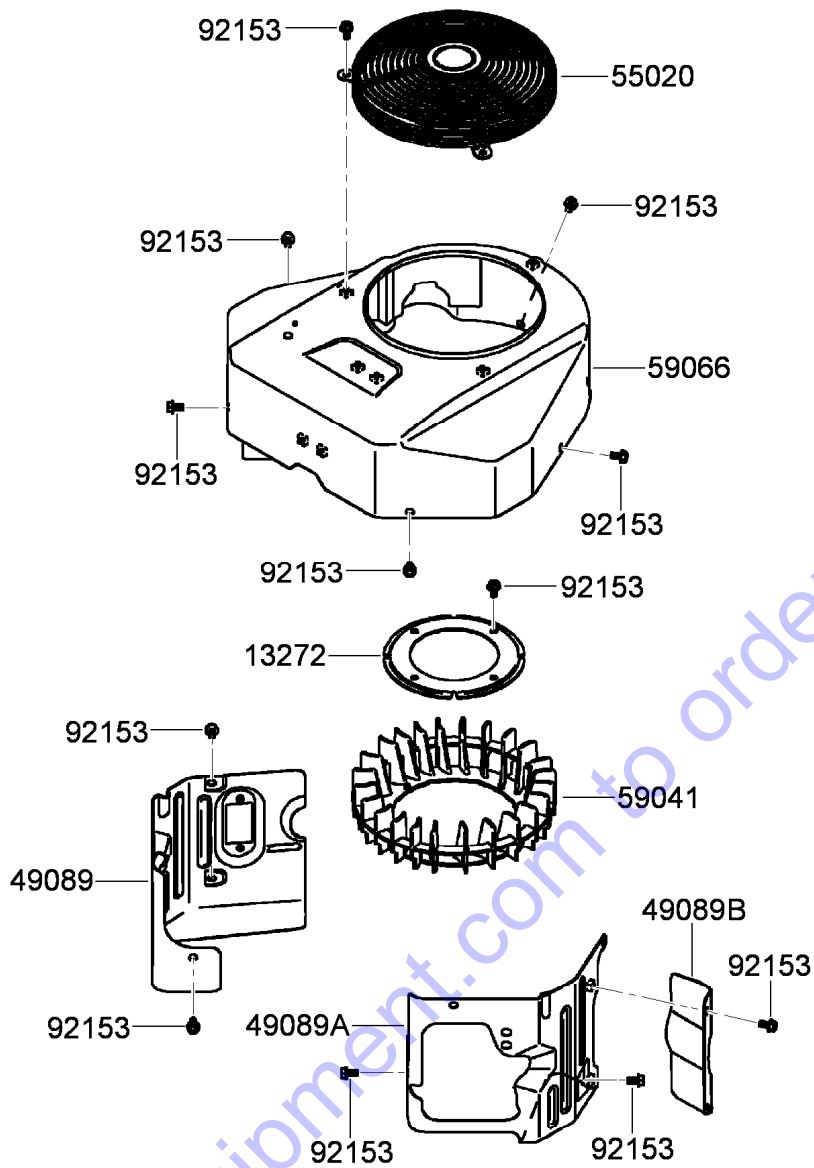

Cooling Equipment Assembly

Ref.	Part Number	Qty.	Description
13272	119-5860	1	Plate-Fan
49089	119-5862	1	Shroud-Engine
49089A	119-5863	1	Shroud-Engine
49089B	119-5864	1	Shroud-Engine
55020	119-5865	1	Guard
59041	119-5867	1	Fan
59066	119-5868	1	Housing-Fan
92153	114-8655	18	Bolt (6X12)

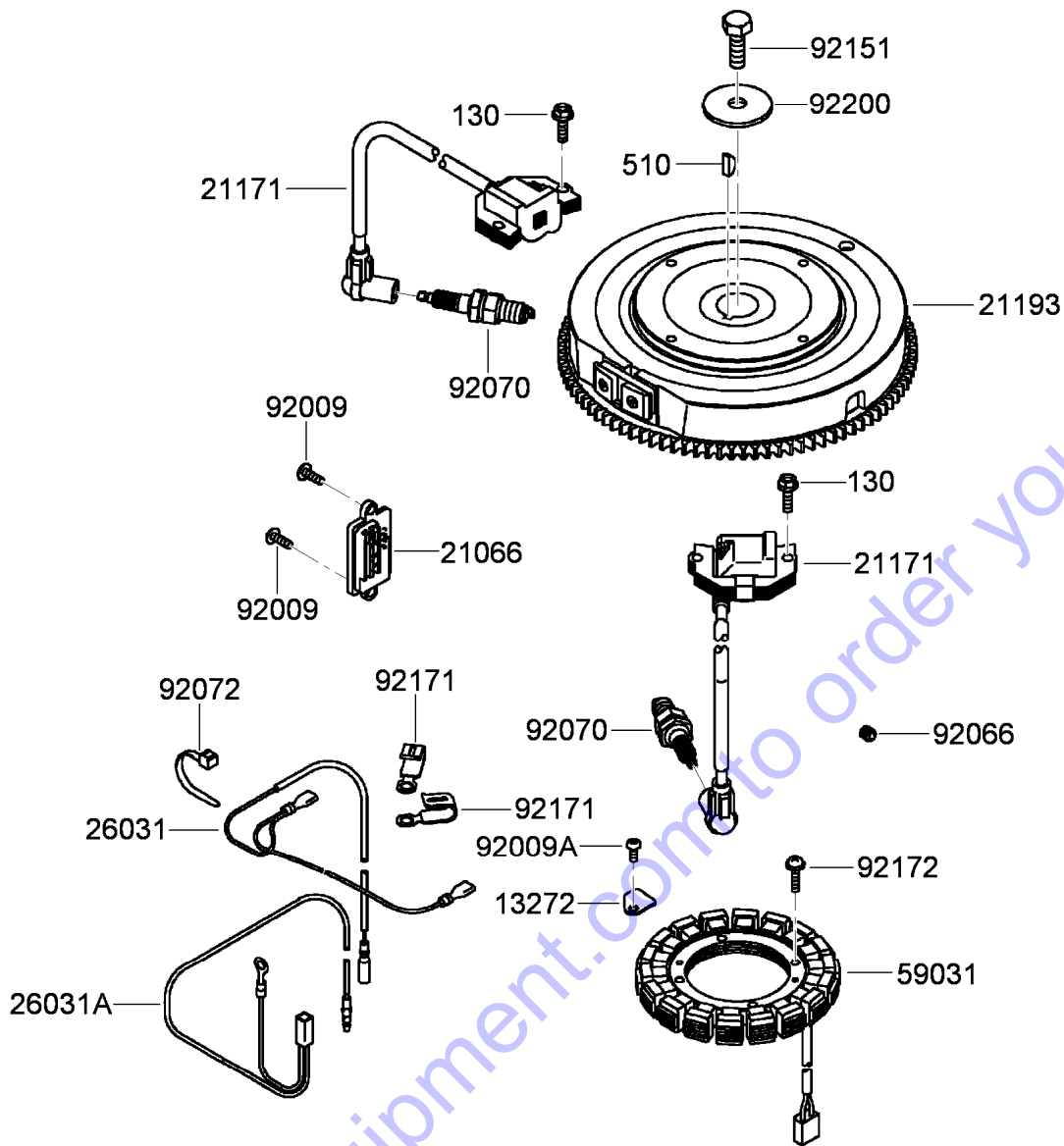

Electric Equipment Assembly

Ref.	Part Number	Qty.	Description
130	95-9893	4	Bolt-Flanged (6X20)
510	KW10163	1	Key-Woodruff
13272	119-5870	1	Plate
21066	120-7356	1	Regulator-Voltage
21171	119-5872	2	Ignition Coil ASM
21193	119-5874	1	Flywheel ASM
26031	119-5876	1	Harness
26031A	119-5877	1	Harness
59031	120-7355	1	Coil-Charging

Ref.	Part Number	Qty.	Description
92009	119-5879	2	Screw
92009A	95-9716	1	Screw
92066	119-5820	1	Plug
92070	92-2153	2	Plug-Spark
92072	115-6585	1	Band
92151	115-6408	1	Bolt (12X30)
92171	115-8665	2	Clamp
92172	115-4030	4	Screw (5X20)
92200	115-4031	1	Washer (12.2X46X3)

Carburetor Assembly

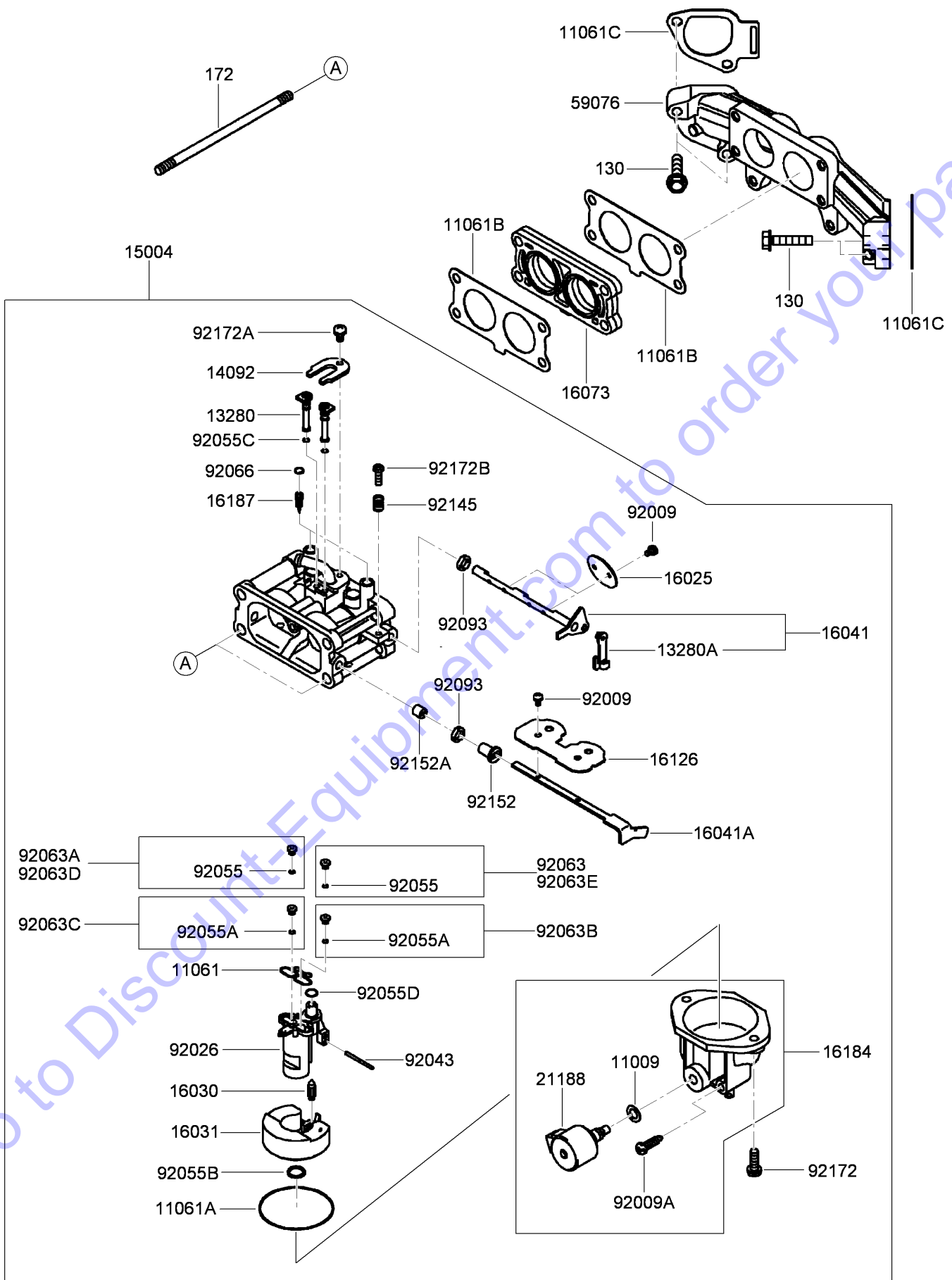

Carburetor Assembly (continued)

<i>Ref.</i>	<i>Part Number</i>	<i>Qty.</i>	<i>Description</i>	<i>Ref.</i>	<i>Part Number</i>	<i>Qty.</i>	<i>Description</i>
130	119-5940	4	Bolt-Flanged (6X30)	92009A	119-5917	1	Screw-Drain
172	119-5941	2	Bolt-Stud (6X115)	92026	119-5918	1	Spacer
11009	119-5895	1	Gasket	92043	119-5919	1	Pin-Float
11061	119-5896	1	Gasket	92055	119-5920	1	O-Ring
11061A	119-5897	1	Gasket	92055A	119-5921	2	O-Ring
11061B	119-5898	2	Gasket-Carburetor/Manifold	92055B	132-8667	1	O-Ring
11061C	119-5899	2	Gasket-Manifold	92055C	119-5923	2	O-Ring
13280	119-5901	2	Holder	92055D	119-5924	1	O-Ring
13280A	119-5902	1	Holder	92063	119-5926	1	Jet-Main (No. 108)
14092	119-5903	1	Cover	92063A	119-5927	1	Jet-Main (No. 104)
15004	119-5904	1	Carburetor ASM	92063B	119-5928	1	Jet-Main (No. 114)
16025	119-5905	2	Valve-Throttle	92063C	119-5929	1	Jet-Main (No. 110)
16030	119-5906	1	Valve-Float	92063D	119-5930	1	Jet-Main (No. 107)
16031	119-5907	1	Float	92063E	119-5931	1	Jet-Main (No. 111)
16041	119-5908	1	Carburetor Throttle Shaft ASM	92066	119-5932	2	Plug-Expansion
16041A	119-5909	1	Shaft-Choke, Carburetor	92093	119-5933	2	Seal (6.9)
16073	119-5910	1	Insulator	92145	119-5934	1	Spring
16126	119-5911	1	Valve	92152	119-5935	1	Collar
16184	119-5912	1	Float Chamber ASM	92152A	119-5936	1	Collar
16187	119-5913	2	Needle-Jet	92172	119-5937	2	Screw (M5)
21188	119-5914	1	Solenoid	92172A	119-5938	1	Screw (M4)
59076	119-5915	1	Manifold-Intake	92172B	119-5939	1	Screw-Adjust, Throttle
92009	119-5916	6	Screw				

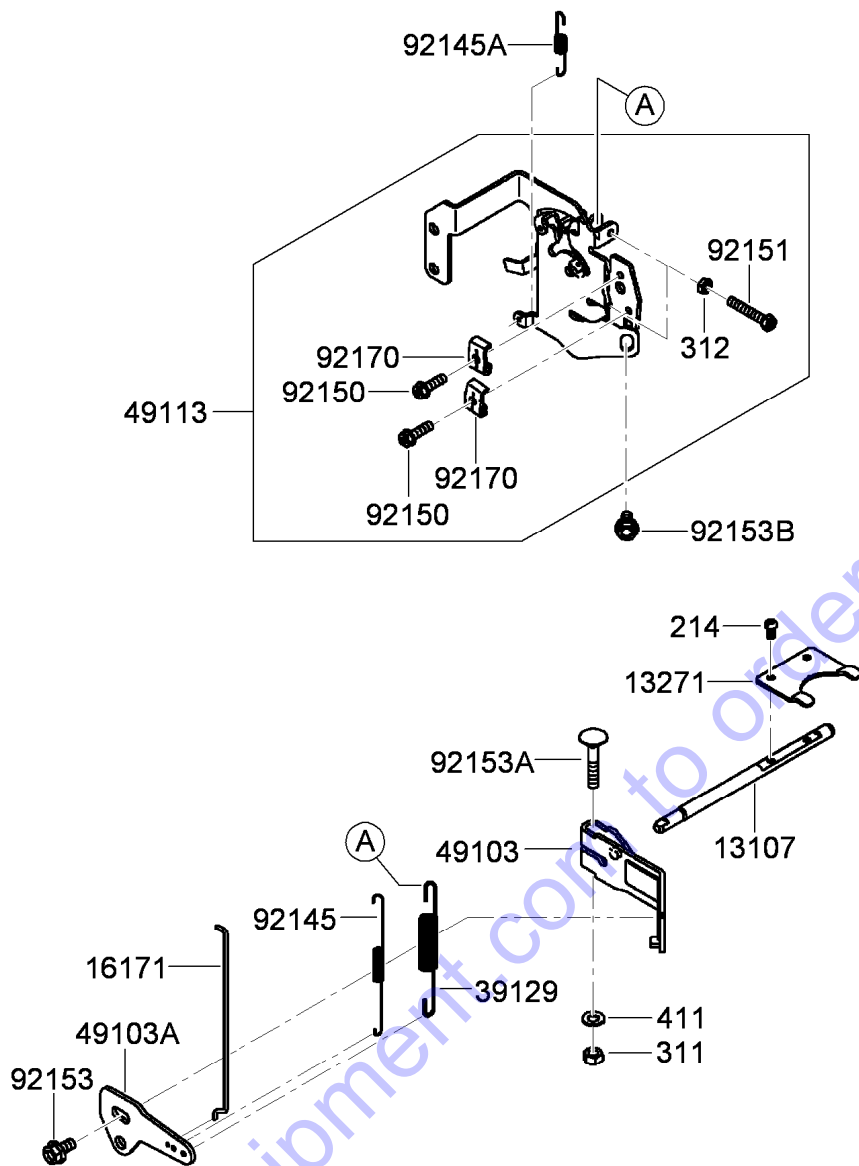

Control Equipment Assembly

Ref.	Part Number	Qty.	Description	Ref.	Part Number	Qty.	Description
214	115-6422	2	Screw-Pan (4X8)	49113	119-5888	1	Control Panel ASM
311	114-8698	1	Nut-Hex (6MM)	92145	119-5889	1	Spring
312	119-5894	2	Nut-Hex (5MM)	92145A	119-5890	1	Spring
411	115-6423	1	Washer-Plain (6MM)	92150	95-9853	2	Bolt (5X18)
13107	119-5882	1	Shaft-Governor	92151	119-5891	2	Bolt (5X30)
13271	119-5883	1	Plate	92153	119-5892	1	Bolt (6X12)
16171	119-5884	1	Link	92153A	115-6420	1	Bolt (6X35)
39129	119-5885	1	Spring-Governor	92153B	119-5892	1	Bolt (6X12)
49103	119-5886	1	Arm-Governor	92170	115-6421	2	Clamp
49103A	119-5887	1	Arm-Governor				

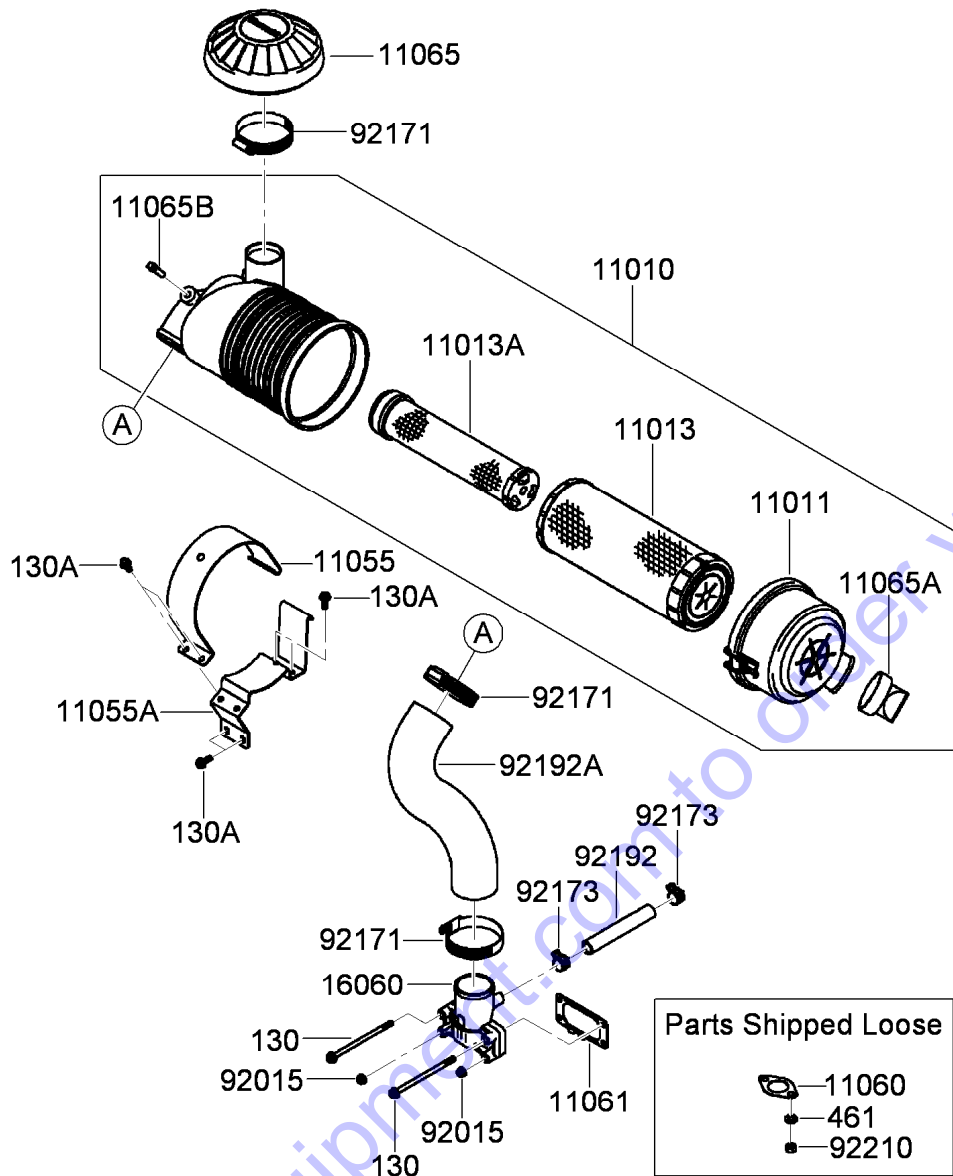

Air Filter and Muffler Assembly

Ref.	Part Number	Qty.	Description	Ref.	Part Number	Qty.	Description
130	119-5960	2	Bolt-Flanged (6X110)	11065	119-5950	1	Cap
130A	119-5961	6	Bolt-Flanged (6X16)	11065A	119-5951	1	Cap
461	119-5962	4	Washer-Spring (8MM)	11065B	119-5952	1	Cap
11010	119-5942	1	Air Filter ASM	16060	119-5953	1	Pipe-Intake
11011	119-5943	1	Case-Filter, Air	92015	119-5954	2	Nut
11013	119-5944	1	Element-Filter, Air (Outer)	92171	119-5955	3	Clamp
11013A	119-5945	1	Element-Filter, Air (Inner)	92173	119-5956	2	Clamp
11055	119-5946	1	Bracket	92192	119-5957	1	Tube (12.6X18.6X118)
11055A	119-5947	1	Bracket	92192A	119-5958	1	Tube
11060	119-5948	2	Gasket-Muffler	92210	119-5959	4	Nut (M8)
11061	119-5949	1	Gasket				

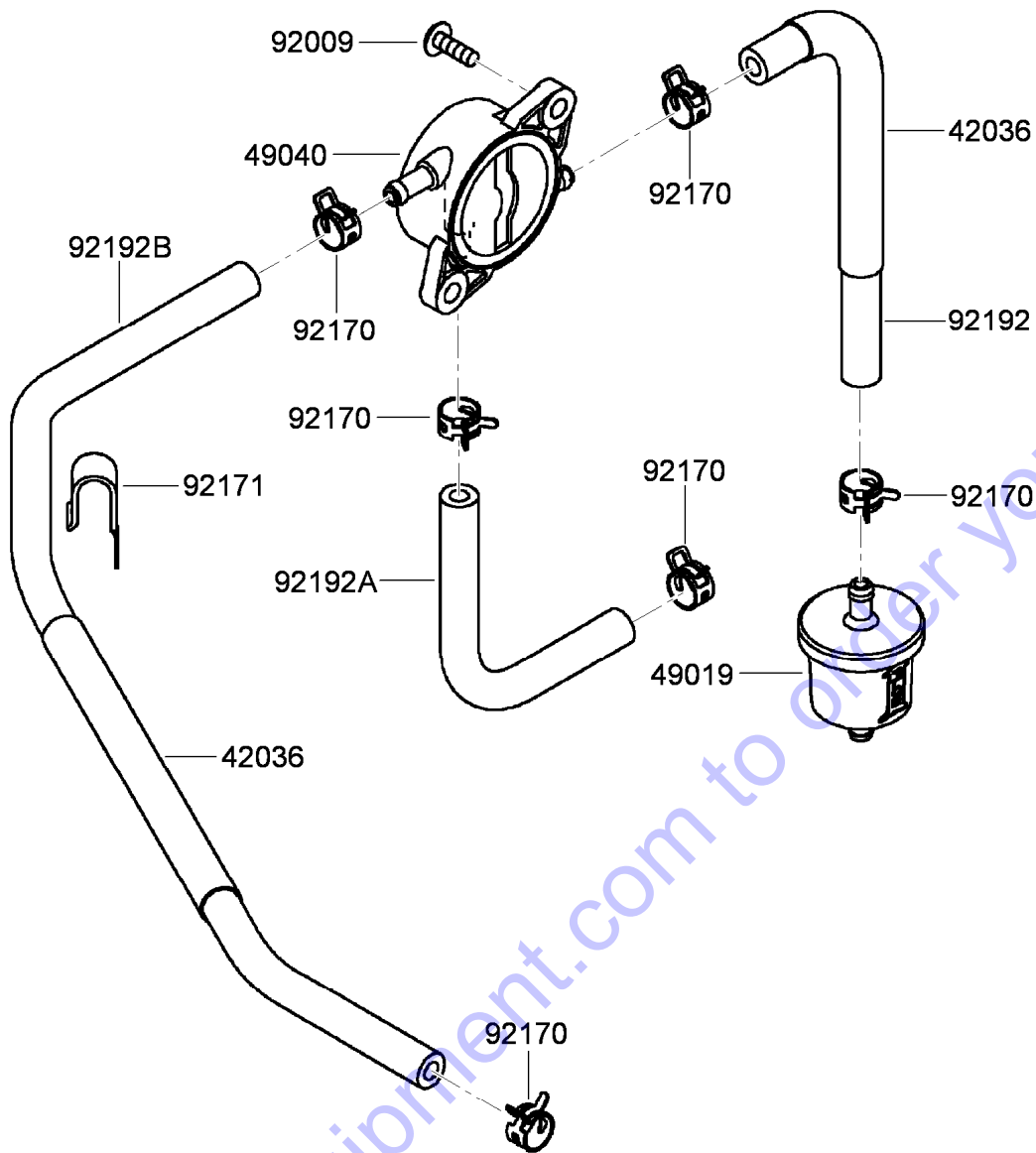

Fuel Tank and Valve Assembly

Ref.	Part Number	Qty.	Description
42036	119-5963	2	Sleeve
49019	121-4570	1	Filter-Fuel
49040	119-5965	1	Pump-Fuel
92009	119-5879	2	Screw
92170	119-5967	6	Clamp
92171	119-5968	1	Clamp
92192	119-5969	1	Tube (6.35X12.7X185)
92192A	119-5970	1	Tube (6.4X12.7X150)
92192B	119-5971	1	Tube (6.35X12.7X390)

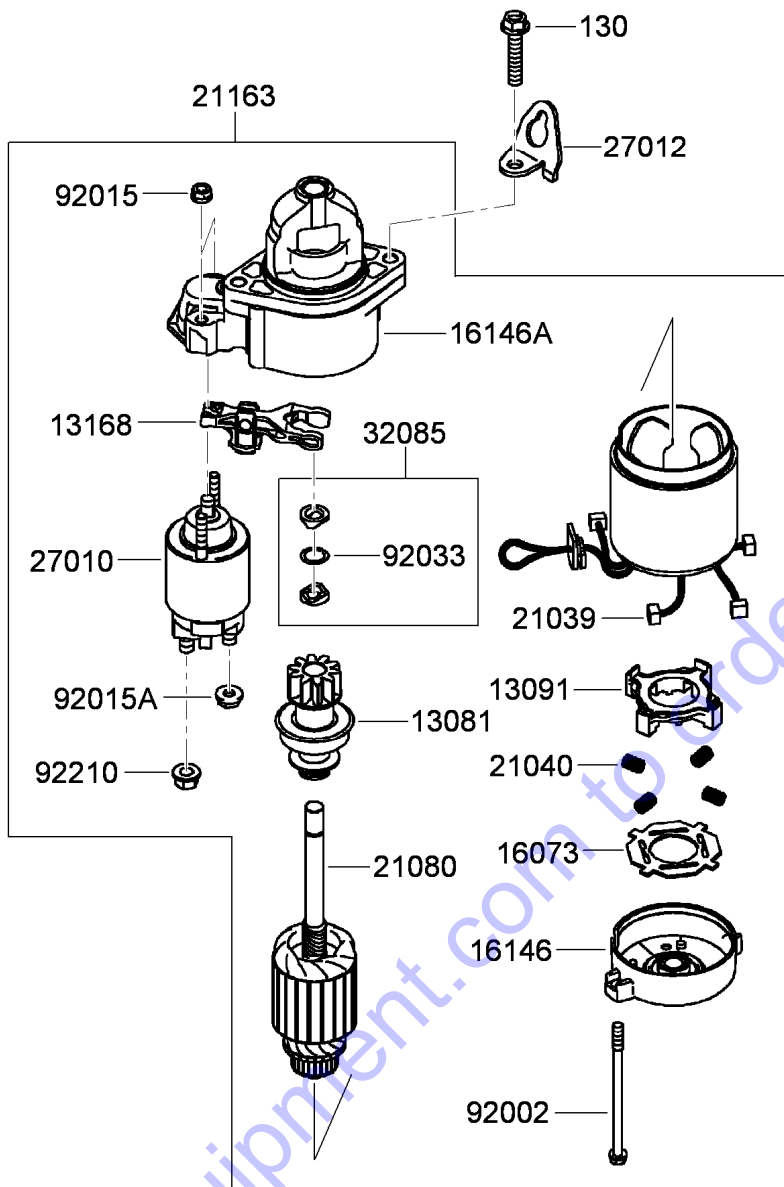

Starter Assembly

Ref.	Part Number	Qty.	Description
130	119-5991	2	Bolt-Flanged (8X40)
13081	119-5972	1	Clutch ASM
13091	119-5973	1	Holder-Brush
13168	119-5974	1	Lever-Shift
16073	119-5975	1	Insulator
16146	119-5976	1	Cover ASM
16146A	119-5977	1	Cover ASM
21039	119-5978	4	Brush
21040	119-5979	4	Spring-Brush
21080	119-5980	1	Armature

Ref.	Part Number	Qty.	Description
21163	119-5981	1	Starter-Electric
27010	119-5982	1	Switch
27012	119-5983	1	Hook
32085	119-5985	1	Stopper
92002	119-5986	2	Bolt
92015	119-5987	2	Nut
92015A	119-5988	1	Nut
92033	119-5989	1	Ring-Snap
92210	119-5990	1	Nut

56014

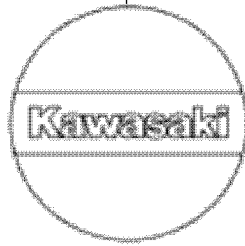

56070

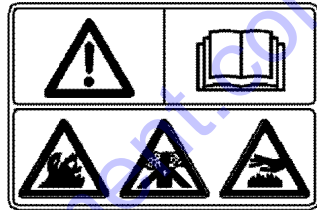

Label Set

<i>Ref.</i>	<i>Part Number</i>	<i>Qty.</i>	<i>Description</i>
56014	119-5992	1	Emblem
56070	115-6469	1	Label-Warning

Attachments and Accessories

For 23208 STX-26 Stump Grinder

Product Name	Model/Part
Spark Arrestor Screen	94-8157
CE Kit	22368
Semi-Gloss Black Spray Paint	361-9
New Red Paint - Gallon	361-11
Decal Kit	145-6940

Go to Discount-Equipment.com to order your parts

PARTS FINDER

**Search Website
by Part Number**



**Search Manual
Library For Parts
Manual & Lookup Part
Numbers – Purchase
or Request Quote**

Search Manuals

Enter your information to help us find the right parts manual for your machine.

* Brand:

* Model:

* Serial:

* Part Number:

SEARCH

**Can't Find Part or
Manual? Request Help
by Manufacturer,
Model & Description**

Parts Order Form

Please fill in the following information to help us find the right part for your machine.

Manufacturer:	<input type="text"/>
Model:	<input type="text"/>
Description:	<input type="text"/>
Part Number:	<input type="text"/>
Quantity:	<input type="text"/>
Notes:	<input type="text"/>

Discount-Equipment.com is your online resource for quality parts & equipment.

Florida: **561-964-4949** Outside Florida TOLL FREE: **877-690-3101**

Need parts?

Click on this link: <http://www.discount-equipment.com/category/5443-parts/> and choose one of the options to help get the right parts and equipment you are looking for. Please have the machine model and serial number available in order to help us get you the correct parts. If you don't find the part on the website or on one of the online manuals, please fill out the request form and one of our experienced staff members will get back to you with a quote for the right part that your machine needs.

We sell worldwide for the brands: Genie, Terex, JLG, MultiQuip, Mikasa, Essick, Whiteman, Mayco, Toro Stone, Diamond Products, Generac Magnum, Airman, Haulotte, Barreto, Power Blanket, Nifty Lift, Atlas Copco, Chicago Pneumatic, Allmand, Miller Curber, Skyjack, Lull, Skytrak, Tsurumi, Husquvarna Target, Stow, Wacker, Sakai, Mi-T-M, Sullair, Basic, Dynapac, MBW, Weber, Bartell, Bennar Newman, Haulotte, Ditch Runner, Menegotti, Morrison, Contec, Buddy, Crown, Edco, Wyco, Bomag, Laymor, EZ Trench, Bil-Jax, F.S. Curtis, Gehl Pavers, Heli, Honda, ICS/PowerGrit, IHI, Partner, Imer, Clipper, MMD, Koshin, Rice, CH&E, General Equipment, Amida, Coleman, NAC, Gradall, Square Shooter, Kent, Stanley, Tamco, Toku, Hatz, Kohler, Robin, Wisconsin, Northrock, Oztec, Toker TK, Rol-Air, APT, Wylie, Ingersoll Rand / Doosan, Innovatech, Con X, Ammann, Mecalac, Makinex, Smith Surface Prep, Small Line, Wanco, Yanmar



Count on it.



www.discount-equipment.com

Go to Discount-Equipment.com to order your parts