

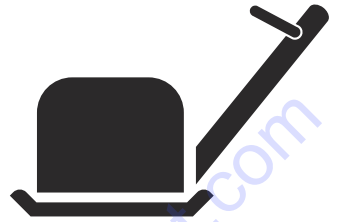

 **Husqvarna**<sup>®</sup>



LG 164, LG 204

EN Operator's manual

2-30

**TO PURCHASE THIS PRODUCT PLEASE CONTACT US**



**Equipment Financing and  
Extended Warranties Available**



**Discount-Equipment.com is your online resource for  
commercial and industrial quality parts and equipment sales.**

**561-964-4949**

**visit us on line @ [www.discount-equipment.com](http://www.discount-equipment.com)**

Select an option below to find your Equipment

**Search by Manufacturer**

**Search by Product Type**

**Request a Quote**

We sell worldwide for the brands: Genie, Terex, JLG, MultiQuip, Mikasa, Essick, Whiteman, Mayco, Toro Stone, Diamond Products, Generac Magnum, Airman, Haulotte, Barreto, Power Blanket, Nifty Lift, Atlas Copco, Chicago Pneumatic, Allmand, Miller Curber, Skyjack, Lull, Skytrak, Tsurumi, Husquvarna Target, Stow, Wacker, Sakai, Mi-T-M, Sullair, Basic, Dynapac, MBW, Weber, Bartell, Bennar Newman, Haulotte, Ditch Runner, Menegotti, Morrison, Contec, Buddy, Crown, Edco, Wyco, Bomag, Laymor, EZ Trench, Bil-Jax, F.S. Curtis, Gehl Pavers, Heli, Honda, ICS/PowerGrit, IHI, Partner, Imer, Clipper, MMD, Koshin, Rice, CH&E, General Equipment, Amida, Coleman, NAC, Gradall, Square Shooter, Kent, Stanley, Tamco, Toku, Hatz, Kohler, Robin, Wisconsin, Northrock, Oztec, Toker TK, Rol-Air, APT, Wylie, Ingersoll Rand / Doosan, Innovatech, Con X, Ammann, Mecalac, Makinex, Smith Surface Prep, Small Line, Wanco, Yanmar

# Contents

|                   |    |                                           |    |
|-------------------|----|-------------------------------------------|----|
| Introduction..... | 2  | Transportation, storage and disposal..... | 21 |
| Safety.....       | 6  | Technical data.....                       | 25 |
| Operation.....    | 10 | EC Declaration of Conformity.....         | 30 |
| Maintenance.....  | 15 |                                           |    |

## Introduction

### Product overview (LG 164)

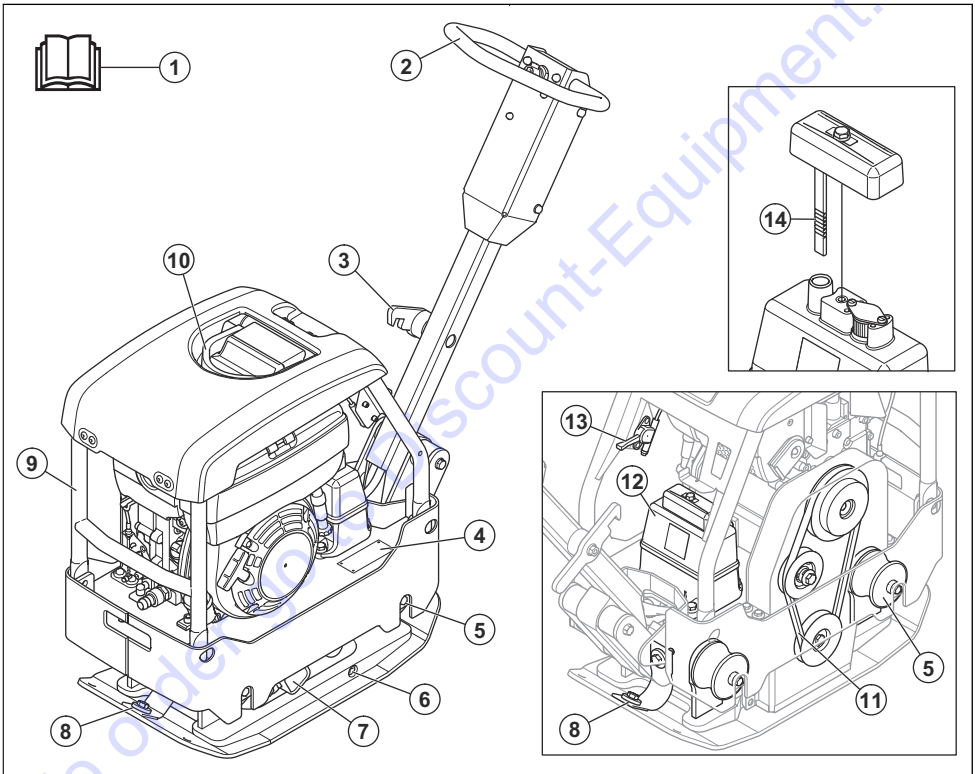

1. Operator's manual
2. Handle
3. Lock lever for the handle
4. Type plate
5. Vibration damping units
6. Oil plug for the eccentric element
7. Eccentric element
8. Safety straps
9. Safety frame
10. Lifting point
11. V-belt
12. Hydraulic oil tank
13. Throttle control
14. Hydraulic oil dipstick

**Note:** There are also 6 vibration damping units between the handle and the engine plate. Refer to *To do a check of the vibration damping units on page 8.*

## Product overview (LG 204)

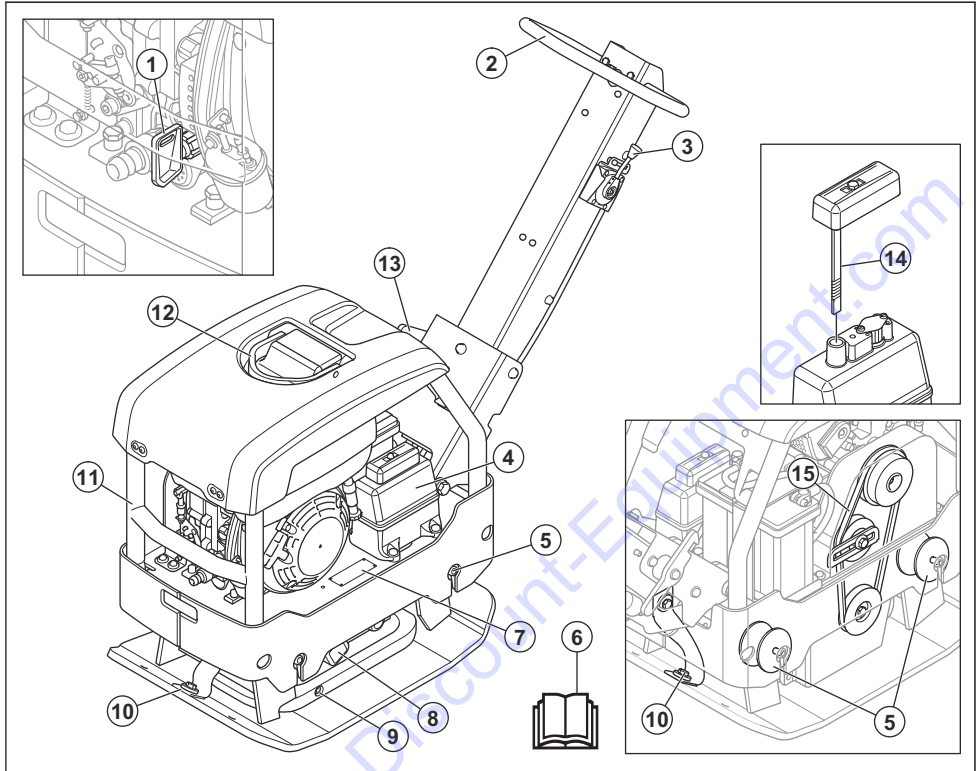

1. Ignition key, only on Hatz engine with electrical start
2. Handle
3. Throttle control
4. Hydraulic oil tank
5. Vibration damping units
6. Operator's manual
7. Type plate
8. Eccentric element
9. Oil plug for the eccentric element
10. Safety straps
11. Safety frame
12. Lifting point
13. Lock lever for the handle
14. Hydraulic oil dipstick
15. V-belt

**Note:** There are also 6 vibration damping units between the handle and the engine plate. Refer to *To do a check of the vibration damping units on page 8.*

# Engine overview

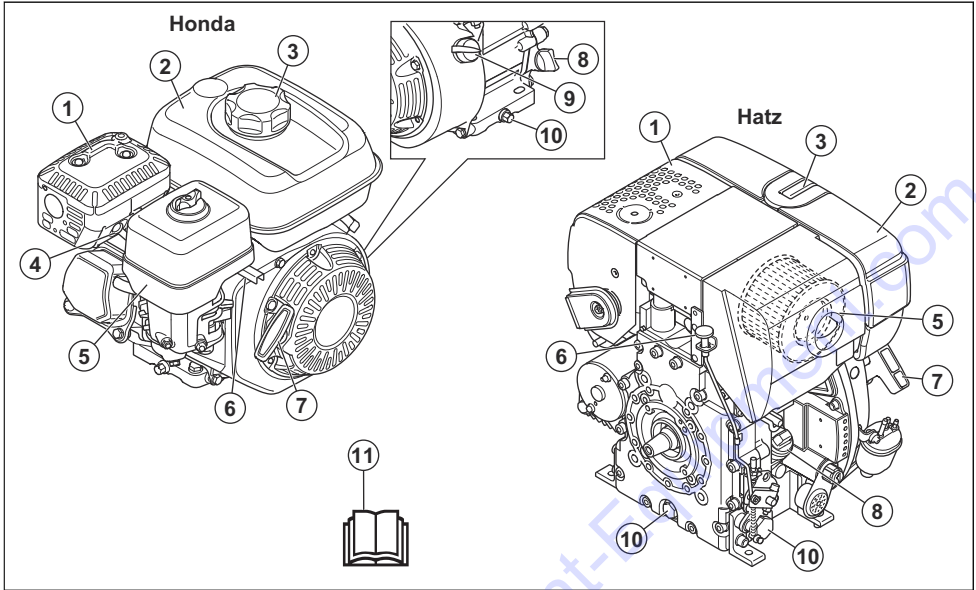

1. Muffler
2. Fuel tank
3. Fuel tank cap
4. Spark plug
5. Air filter
6. Throttle control
7. Starter rope handle
8. Oil tank / dipstick
9. Engine ON/OFF switch
10. Drain plug for engine oil
11. Operator's manual



Read the manual carefully and make sure that you understand the instructions before you use the product.



Read the manual carefully and make sure that you understand the instructions before you use the product.



Use hearing protection.



Use protective boots.



Fuel: Unleaded gasoline with a maximum of 10% ethanol.



Ultra-low-sulfur diesel fuel only.

## Product description

The product is a walk-behind reversible plate compactor for compaction of granular soils in moderately thick layers to layers of larger depth.

## Intended use

The product is for professional operation only. Use the product for repairs and maintenance of driveways, paths and parking lots. With the optional block paving kit the product can also be used for block paving. Do not use the product for other tasks.

## Symbols on the product



Be careful and use the product correctly. This product can cause serious injury or death to the operator or others.



Manual start.



Electrical start.



Hydraulic oil level.



The vibrations start. Symbol for a position of the throttle control.



Risk of injury. Be careful around the drive belt.



Risk of injury if the handle falls on you. Lock the handle in the lifted position.



Hot surface.

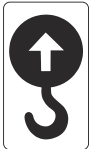

Lifting point on the safety frame.



Noise emission to the environment as referred to in the EC directive. The emission of the product is specified in *Technical data on page 25* and on the label.



This product is in compliance with applicable EC directives.



Move the product forward.

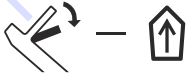

Move the product rearward.

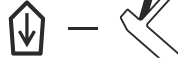

**Note:** Other symbols/decals on the product refer to special certification requirements for some markets.

## Type plate



1. Product type
2. Product number
3. Product weight
4. Serial number
5. Manufacturer
6. Rated power
7. Production year

## Product liability

As referred to in the product liability laws, we are not liable for damages that our product causes if:

- the product is incorrectly repaired.
- the product is repaired with parts that are not from the manufacturer or not approved by the manufacturer.
- the product has an accessory that is not from the manufacturer or not approved by the manufacturer.
- the product is not repaired at an approved service center or by an approved authority.

---

# Safety

---

## Safety definitions

Warnings, cautions and notes are used to point out specially important parts of the manual.



**WARNING:** Used if there is a risk of injury or death for the operator or bystanders if the instructions in the manual are not obeyed.



**CAUTION:** Used if there is a risk of damage to the product, other materials or the adjacent area if the instructions in the manual are not obeyed.

**Note:** Used to give more information that is necessary in a given situation.

## General safety instructions



**WARNING:** Read the warning instructions that follow before you use the product.

- This product is a dangerous tool if you are not careful or if you use the product incorrectly. This product can cause serious injury or death to the operator or others. Before you use the product, you must read and understand the contents of this operator's manual.
- Save all warnings and instructions.
- Comply with all applicable laws and regulations.
- The operator and the employer of the operator must know and prevent the risks during operation of the product.
- Do not let a person operate the product unless they read and understand the contents of the operator's manual.
- Do not operate the product unless you receive training before use. Make sure that all operators receive training.
- Do not let a child operate the product.
- Only let approved persons operate the product.
- The operator is responsible for accidents that occur to other persons or their property.
- Do not use the product if you are tired, ill, or under the influence of alcohol, drugs or medicine.
- Always be careful and use your common sense.
- This product produces an electromagnetic field during operation. This field can under some circumstances interfere with active or passive medical implants. To decrease the risk of serious injury or death, we recommend persons with medical implants to speak to their physician and the medical implant manufacturer before operating this product.
- Keep the product clean. Make sure that you can clearly read signs and decals.
- Do not use the product if it is defective.
- Do not do modifications to this product.
- Do not operate the product if it is possible that other persons have done modifications to the product.

## Safety instructions for operation



**WARNING:** Read the warning instructions that follow before you use the product.

- Make sure that you know how to stop the engine quickly in an emergency.
- The operator must have the physical strength that is necessary to operate the product safely.
- Do not operate the product without all protective covers installed.
- Use personal protective equipment. Refer to *Personal protective equipment on page 8*.
- Make sure that only approved persons are in the work area.
- Keep the work area clean and bright.
- Make sure that you are in a safe and stable position during operation.
- Make sure that there is no risk that you or the product can fall from a height.
- Make sure that there is no grease or oil on the handle.
- Do not use the product in areas where fire or explosions can occur.
- The product can cause objects to eject at high speed. Make sure that all persons in the work area use approved personal protective equipment. Remove loose objects from the work area.
- Before you go away from the product, stop the engine and make sure that there is no risk of accidental start.
- Make sure that clothes, long hair and jewelry do not get caught in moving parts.
- Do not sit on the product.
- Do not hit the product.
- Always operate the product from behind with your hands on the handle.
- Do not operate the product near electrical cables. The product does not have electrical insulation and injury or death can occur.
- Before you operate the product, find out if there are hidden wires, cables and pipes in the work area. If the product hits a hidden object, stop the engine immediately and examine the product and the object. Do not start to operate the product again until you know that it is safe to continue.

## Vibration safety

---



**WARNING:** Read the warning instructions that follow before you use the product.

- During operation of the product, vibrations go from the product to the operator. Regular and frequent operation of the product can cause or increase the degree of injuries to the operator. Injuries can occur in fingers, hands, wrists, arms, shoulders, and/or nerves and blood supply or other body parts. The injuries can be debilitating and/or permanent, and can increase gradually during weeks, months or years. Possible injuries include damage to the blood circulation system, the nervous system, joints, and other body structures.
- Symptoms can occur during operation of the product or at other times. If you have symptoms and continue to operate the product, the symptoms can increase or become permanent. If these or other symptoms occur, get medical aid:
  - Numbness, loss of feeling, tingling, pricking, pain, burning, throbbing, stiffness, clumsiness, loss of strength, changes in skin color or condition.
- Symptoms can increase in cold temperatures. Use warm clothing and keep your hands warm and dry when you operate the product in cold environments.
- Do maintenance on and operate the product as given in the operator's manual, to keep a correct vibration level.
- The product has a vibration damping system that decreases the vibrations from the handles to the operator. Let the product do the work. Do not push the product with force. Hold the product at the handles lightly, but make sure that you control the product and operate it safely. Do not push the handles into the end stops more than necessary.
- Keep your hands on the handle or handles only. Keep all other body parts away from the product.
- Stop the product immediately if strong vibrations suddenly occurs. Do not continue the operation before the cause of the increased vibrations is removed.

## Dust safety

---



**WARNING:** Read the warning instructions that follow before you use the product.

- Operation of the product can cause dust in the air. Dust can cause serious injury and permanent health problems. Silica dust is regulated as harmful by several authorities. These are examples of such health problems:
  - The fatal lung diseases chronic bronchitis, silicosis and pulmonary fibrosis

- Cancer
- Birth defects
- Skin inflammation
- Use correct equipment to decrease the quantity of dust and fumes in the air and to decrease dust on work equipment, surfaces, clothing and body parts. Examples of controls are dust collection systems and water sprays to bind dust. Decrease dust at the source where possible. Make sure that the equipment is correctly installed and used and that regular maintenance is done.
- Use approved respiratory protection. Make sure that the respiratory protection is applicable for the dangerous materials in the work area.
- Make sure that the airflow is sufficient in the work area.
- If it is possible, point the exhaust of the product where it cannot cause dust to go into the air.

## Exhaust fumes safety

---



**WARNING:** Read the warning instructions that follow before you use the product.

- The exhaust fumes from the engine contain carbon monoxide which is an odourless, poisonous and very dangerous gas. To breathe carbon monoxide can cause death. Because carbon monoxide is odourless and cannot be seen, it is not possible to sense it. A symptom of carbon monoxide poisoning is dizziness, but it is possible that a person becomes unconscious without warning if the quantity or concentration of carbon monoxide is sufficient.
- Exhaust fumes also contain unburned hydrocarbons including benzene. Long-term inhalation can cause health problems.
- Exhaust fumes that you can see or smell also contain carbon monoxide.
- Do not use a combustion engine product indoors or in areas that do not have sufficient airflow.
- Do not breathe the exhaust fumes.
- Make sure that the airflow in the work area is sufficient. This is very important when you operate the product in trenches or other small work areas where exhaust fumes can easily collect.

## Noise safety

---



**WARNING:** Read the warning instructions that follow before you use the product.

- High noise levels and long-term exposure to noise can cause noise-induced hearing loss.
- To keep the noise level to a minimum, do maintenance on and operate the product as given in the operator's manual.



- Examine the muffler for damages and defects. Make sure that the muffler is correctly attached to the product.
- Use approved hearing protection while you operate the product.
- Listen for warning signals and voices when you use hearing protection. Remove the hearing protection when the product is stopped, unless hearing protection is necessary for the noise level in the work area.

2. Set the engine ON/OFF switch to "OFF". The engine stops.

### Muffler

The muffler keeps the noise levels to a minimum and sends the exhaust fumes away from the operator.

Do not use the product if the muffler is missing or defective. A defective muffler increases the noise level and the risk of fire.

## Personal protective equipment



**WARNING:** Read the warning instructions that follow before you use the product.



**WARNING:** The muffler becomes very hot during and after use and when the engine operates at idle speed. Be careful near flammable materials and/or fumes to prevent fire.

- Always use approved personal protective equipment when you operate the product. Personal protective equipment cannot fully prevent injury but it decreases the degree of injury if an accident does occur. Let your dealer help you select the correct personal protective equipment.
- Regularly do a check of the condition of the personal protective equipment.
- Use an approved protective helmet.
- Use approved hearing protection.
- Use approved respiratory protection.
- Use approved eye protection with side protection.
- Use protective gloves.
- Use boots with steel toe-cap and non-slip sole.
- Use approved work clothing or equivalent close-fitting clothing that has long sleeves and long legs.

### To do a check of the muffler

- Examine the muffler regularly to make sure that it is attached correctly and not damaged.

### Safety frame

The safety frame prevents damage to the product if it falls.

### To do a check of the safety frame

- Make sure that there are no cracks or other damages on the safety frame.
- Make sure that the safety frame is correctly installed on the product.

### Vibration damping units

The vibration damping units decrease vibration in the product. The vibration damping units decrease harmful vibrations to prevent injury to the operator and damage to the product.

### To do a check of the vibration damping units

There are 10 vibration damping units, 2 on each side of the product, and 6 between the handle and the engine plate.

Model LG 164:

### Fire extinguisher

- Keep a fire extinguisher near during operation.
- Use a powder fire extinguisher of "ABE" class or a carbon dioxide fire extinguisher of "BE" type.

## Safety devices on the product



**WARNING:** Read the warning instructions that follow before you use the product.

- Do not use a product with defective safety devices.
- Do a check of the safety devices regularly. If the safety devices are defective, speak to Discount-equipment.

### Engine ON/OFF switch

The engine can only start when the engine ON/OFF switch is set to "ON". The engine stops when you set the engine ON/OFF switch to "OFF".

### To do a check of the engine ON/OFF switch

1. Start the engine. Refer to *To start and stop the product on page 10*.

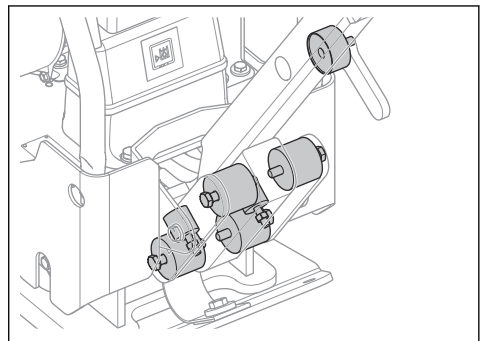

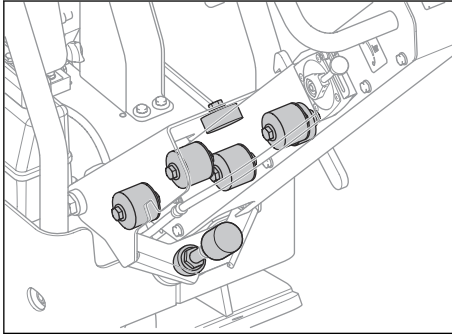

- Make sure that the vibration damping units are correctly installed.
- Examine the vibration damping units for damages and wear.
- Replace the vibration damping units if it is necessary.

### Fuel safety



**WARNING:** Read the warning instructions that follow before you use the product.

- Fuel is flammable and the fumes are explosive. Be careful with fuel to prevent injury, fire and explosion.
- Do not breathe in the fuel fumes. The fuel fumes are poisonous and can cause injury. Make sure that the airflow is sufficient.
- Do not remove the fuel tank cap or fill the fuel tank when the engine is on.
- Let the engine become cool before you refuel.
- Do not fill fuel in an indoor area. Not sufficient airflow can cause injury or death because of asphyxiation or carbon monoxide.
- Do not smoke near the fuel or the engine.
- Do not put hot objects near the fuel or the engine.
- Do not fill fuel near sparks or flames.
- Before you refuel, open the fuel tank cap slowly and release the pressure carefully.
- Fuel on your skin can cause injury. If you get fuel on your skin, use soap and water to remove the fuel.
- If you spill fuel on your clothing, change clothing immediately.
- Do not fill the fuel tank fully. Heat causes the fuel to expand. Keep a space at the top of the fuel tank.
- Tighten the fuel tank cap fully. If the fuel tank cap is not tightened, there is a risk of fire.
- Before you start the product, move the product to a minimum of 3 m/10 ft from where you refueled.
- Do not start the product if there is fuel or engine oil on the product. Remove the unwanted fuel and

engine oil and let the product dry before you start the engine.

- Examine the engine for leaks regularly. If there are leaks in the fuel system, do not start the engine until the leaks are repaired.
- Do not use your fingers to examine the engine for leaks.
- Keep fuel in approved containers only.
- When the product and fuel is in storage, make sure that fuel and fuel fumes cannot cause damage.
- Drain the fuel in an approved container outdoors and away from sparks and flames.

### Battery safety



**WARNING:** A damaged battery can cause an explosion and cause injury. If the battery has a deformation or is damaged, speak to Discount-equipment.



**WARNING:** Read the warning instructions that follow before you use the product.

- Use protective glasses when you are near batteries.
- Do not wear watches, jewelry or other metal objects near the battery.
- Keep the battery out of reach for children.
- Charge the battery in a space with good airflow.
- Keep flammable materials at a minimum clearance of 1 m when you charge the battery.
- Discard replaced batteries. See *Disposal on page 24*.
- Explosive gases can come from the battery. Do not smoke near the battery. Keep the battery away from open flames and sparks.

### Safety instructions for operation on slopes



**WARNING:** Read the warning instructions that follow before you use the product.

- Do not operate the product on a slope that is more than 20°. Loose ground, vibrations and the operation speed can cause the product to fall on a slope that is less than 20°.
- Make sure that the work area is safe. Wet and loose soil decreases safe operation of the product. Be very careful on slopes and rough surfaces.
- Make sure that all persons in the work area are above the product on the slope.
- Operate the product up and down the slope, not from side to side.
- Do not park the product on a slope. If you must park the product on a slope, make sure that the product cannot fall. There is a risk of injury and damage.

## Safety instructions for operation near edges



**WARNING:** Read the warning instructions that follow before you use the product.

- There is a risk that the product falls when you operate it near an edge. Always keep a minimum of  $\frac{2}{3}$  of the product on a surface that is sufficiently stable to hold the product weight.
- If the product falls, stop the engine before you lift the product back to a surface that is sufficiently stable. Refer to *To lift the product on page 23*.

## Safety instructions for maintenance



**WARNING:** Read the warning instructions that follow before you use the product.

- If the maintenance is not done correctly and regularly, the risk of injury and damage to the product increases.
- Use personal protective equipment. Refer to *Personal protective equipment on page 8*.
- Stop the engine and make sure that all parts of the product are cool before you do the maintenance.

- Clean the product to remove dangerous material before you do the maintenance.
- Disconnect the spark plug cap before you do the maintenance.
- The exhaust fumes from the engine are hot and can contain sparks. Do not operate the product in indoor areas or near flammable material.
- Do not change the product. Modifications that are not approved by the manufacturer, can cause serious injury or death.
- Always use original accessories and spare parts. Accessories and spare parts that are not approved by the manufacturer, can cause serious injury or death.
- Replace damaged, worn or broken parts.
- Only do the maintenance as given in this operator's manual. Let an approved service center do all other servicing.
- Remove all tools from the product before you start the engine after maintenance. Loose tools or tools attached to rotating parts can eject and cause injury.
- After maintenance, do a check of the vibration level in the product. If it is not correct, speak to an approved service center.
- Let an approved service center do servicing on the product regularly.

# Operation

## Introduction



**WARNING:** Read and understand the safety chapter before you use the product.

## To do before you operate the product

- Read the operator's manual carefully and make sure that you understand the instructions.
- Read the engine manual that is supplied by the engine manufacturer.
- Do the daily maintenance. Refer to *Maintenance schedule on page 15*.

## To set the handle to operation position



**WARNING:** Hold the handle tightly when you change the position of the handle. There is a risk of injury if the handle falls on you.

1. Hold the handle.

2. Release the lock lever and lower the handle carefully.

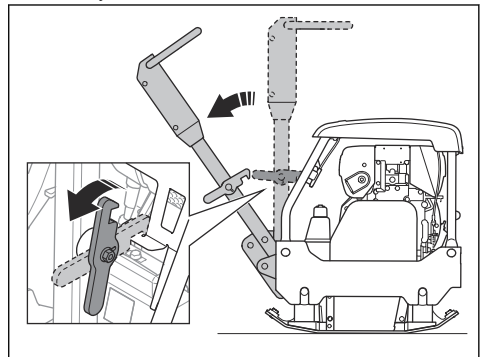

## To start and stop the product



**WARNING:** Keep your feet away from the product during the start procedure. The hydraulic system can cause the product to move suddenly when the engine starts.

## To start the product (LG 164, Honda)

1. Open the fuel valve.

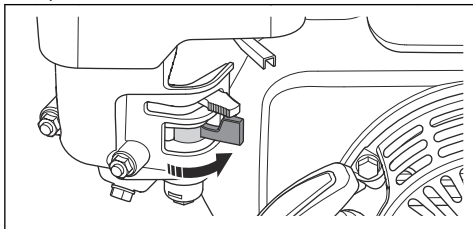

2. Set the throttle control to idle speed.

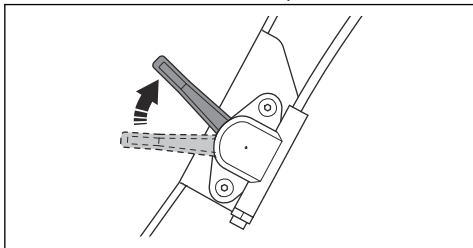

3. Set the choke control in the correct position.

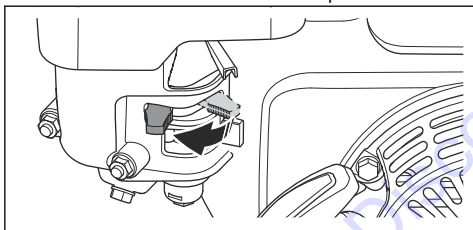

- a) If the engine is cold, close the choke.
- b) If the engine is warm or the ambient temperature is high, open the choke.

4. Set the engine ON/OFF switch to ON.

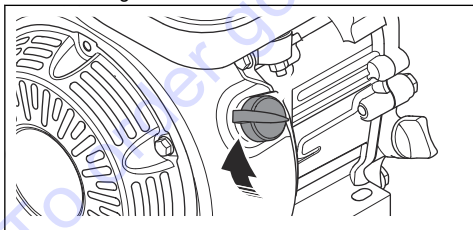

5. Pull the starter rope handle slowly until you feel resistance.

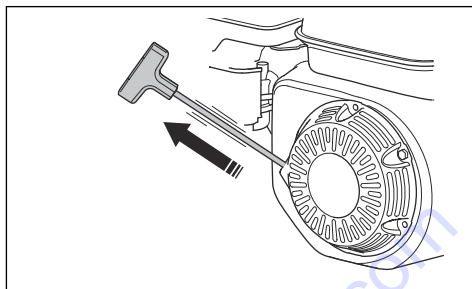

6. Release the starter rope handle to let the starter rope go back.
7. Pull the starter rope handle until the engine starts.
8. Open the choke control gradually until it is fully open.

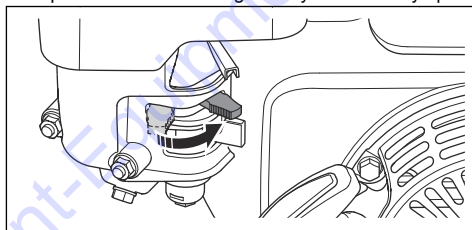

9. Let the engine operate at idle speed for 2-3 minutes.
10. Set the throttle control to full throttle.

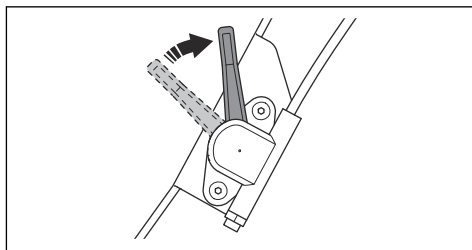

## To start the product (LG 204, Honda)

1. Open the fuel valve.

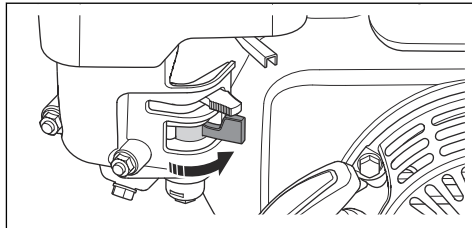

- Set the throttle control to idle speed.

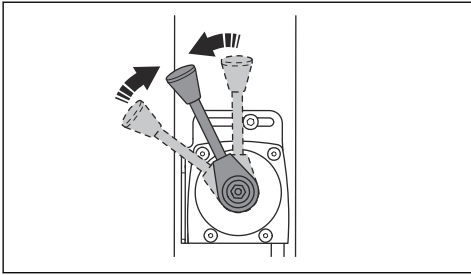

- Set the choke control in the correct position.

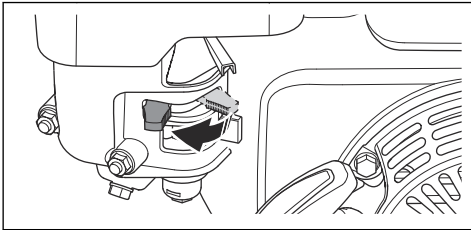

- If the engine is cold, close the choke.
- If the engine is warm or the ambient temperature is high, open the choke.

- Set the engine ON/OFF switch to ON.

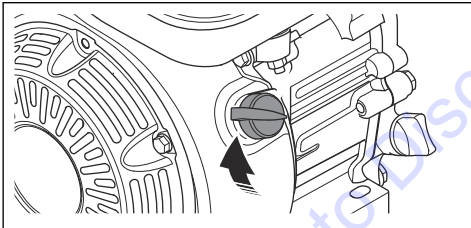

- Pull the starter rope handle slowly until you feel resistance.

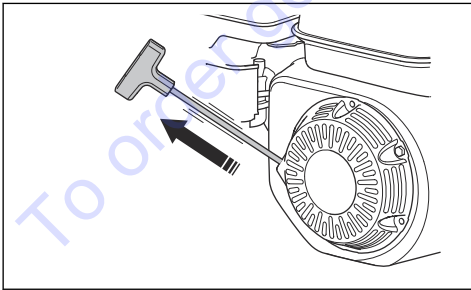

- Release the starter rope handle to let the starter rope go back.
- Pull the starter rope handle until the engine starts.

- Open the choke control gradually until it is fully open.

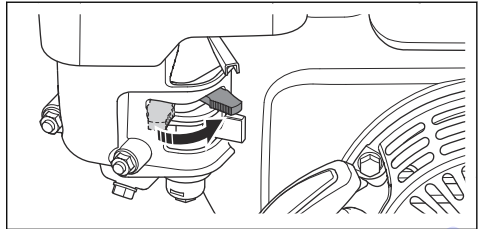

- Let the engine operate at idle speed for 2–3 minutes.

- Set the throttle control to full throttle.

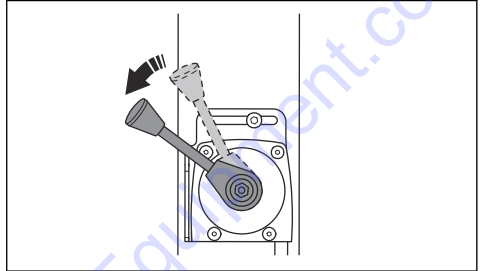

### To stop the product (Honda)

- Set the throttle control to idle speed.

- LG 164:

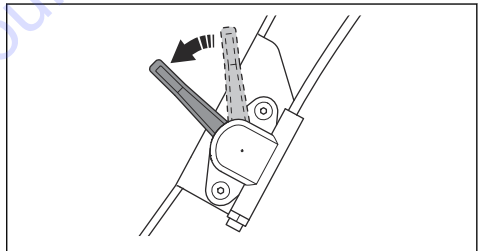

- LG 204:

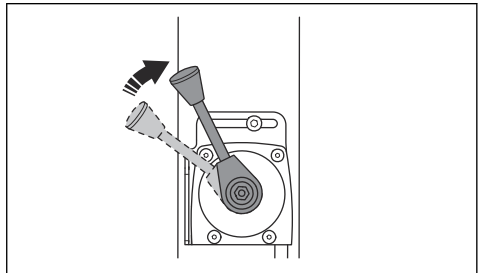

- Let the engine operate at idle speed for 2–3 minutes.
- Set the engine ON/OFF switch to OFF. The engine stops.
- Move the fuel valve to the OFF position.

## To start the product (LG 164, Hatz)

1. Set the throttle control to idle speed.

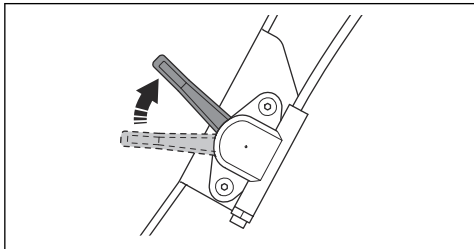

2. Pull the starter rope handle slowly until you feel resistance.

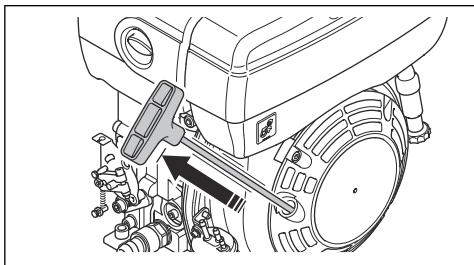

3. Release the starter rope handle to let the starter rope go back.
4. Pull the starter rope handle until the engine starts.
5. Let the engine operate at idle speed for 2–3 minutes.
6. Set the throttle control to full throttle.

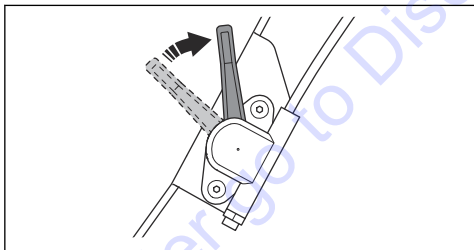

## To start the product manually (LG 204, Hatz)

1. Set the throttle control to idle speed.

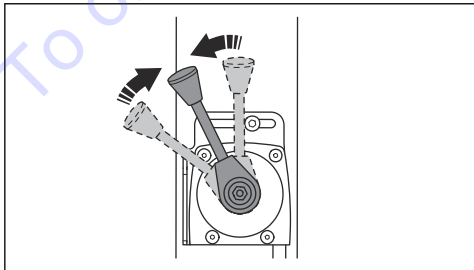

2. Pull the starter rope handle slowly until you feel resistance.

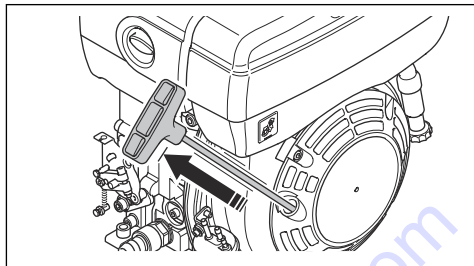

3. Release the starter rope handle to let the starter rope go back.
4. Pull the starter rope handle until the engine starts.
5. Let the engine operate at idle speed for 2–3 minutes.
6. Set the throttle control to full throttle.

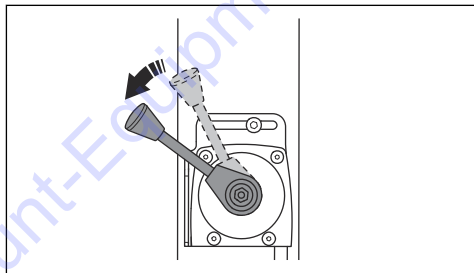

## To start the product, electrical start (LG 204, Hatz)

1. Set the throttle control to idle speed.

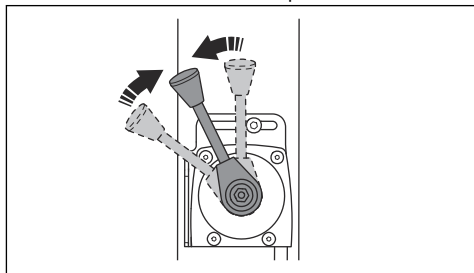

2. Turn the ignition key to the ignition position (A). The indicators for battery charge and oil pressure come on (B).

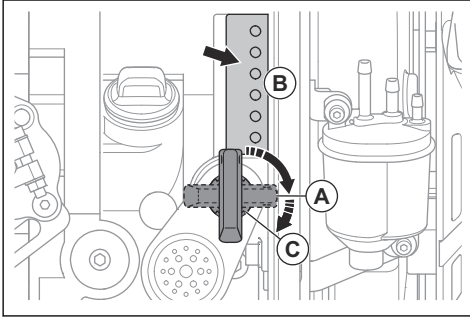

3. Turn the ignition key to the start position (C).
  - a) When the engine starts, immediately release the ignition key. The ignition key goes to the ignition position (A).
  - b) If the engine does not start in 10 seconds, release the ignition key and wait 5 seconds before you try again.
4. Let the engine operate at idle speed for 2–3 minutes.
5. Set the throttle control to full throttle.

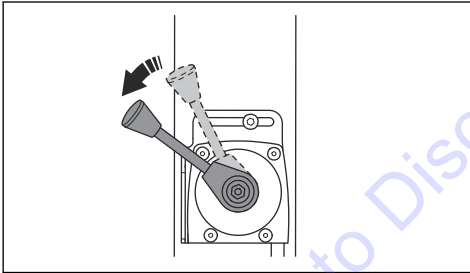

### To stop the product (Hatz)

1. Park the product on level ground.
2. Set the throttle control to idle speed.
3. Let the engine operate at idle speed for 2–3 minutes.
4. Set the throttle control to the stop position. This stops the engine if it has a manual start.
  - a) (LG 164, Hatz):

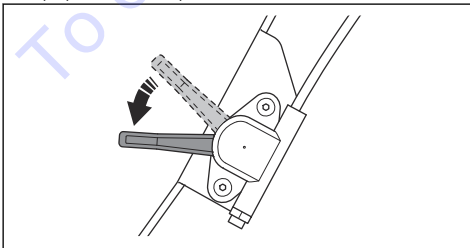

- b) (LG 204, Hatz):

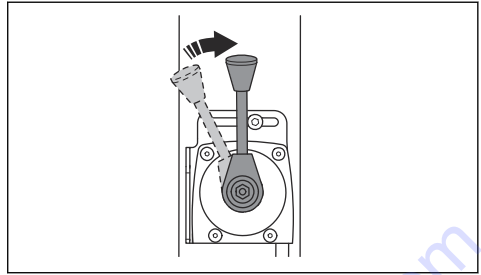

5. If the engine has an electrical start, do also these steps:

- a) Turn the ignition key to the stop position.

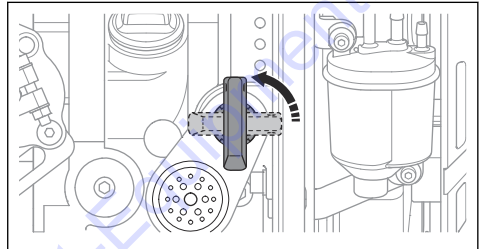

- b) Remove the ignition key to prevent accidental start.

### To operate the product

Always operate the product with the throttle control set to full throttle.

- To operate the product forward, move the operation control fully forward and release it.

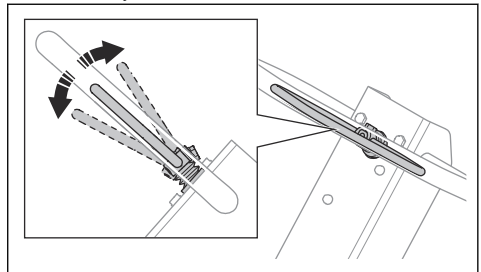

- To operate the product rearward, move the operation control fully rearward and release it.
- To stop the movement of the product, move the operation control in the opposite direction in small movements until the product is stationary.
- To change direction, turn the product around by the handle.

# Maintenance

## Introduction



**WARNING:** Read and understand the safety chapter before you do maintenance on the product.

X = The instructions are given in this operator's manual.

O = Refer to the instructions in the engine manual supplied by the engine manufacturer.

## Maintenance schedule

\* = General maintenance done by the operator. The instructions are not given in this operator's manual.

| General product maintenance                                                                                   | Before use, each 10 h | Weekly, each 100 h | Monthly, each 250 h | Yearly, each 500 h |
|---------------------------------------------------------------------------------------------------------------|-----------------------|--------------------|---------------------|--------------------|
| Make sure that there are no fuel or oil leaks.                                                                | *                     |                    |                     |                    |
| Clean the product.                                                                                            | X                     |                    |                     |                    |
| Make sure that nuts and screws are tightened.                                                                 | *                     |                    |                     |                    |
| Examine the forward and reverse control, the throttle control and the choke control for damage.               | *                     |                    |                     |                    |
| Make sure that the forward and reverse control, the throttle control and the choke control can move smoothly. | *                     |                    |                     |                    |
| Lubricate the controls and linkages.                                                                          | *                     |                    |                     |                    |
| Examine the safety straps for damage. Replace if it is necessary.                                             | X                     |                    |                     |                    |
| Examine the vibration damping units for damage.                                                               |                       | X                  | X                   | X                  |
| Examine the tension of the V-belt and look for damages. Adjust or replace the V-belt as necessary.            |                       | X                  | X                   | X                  |
| Examine all rubber hoses and rubber elements for damage. Replace if it is necessary.                          |                       |                    | X                   |                    |
| Do a check of the hydraulic oil level.                                                                        |                       |                    | X                   |                    |
| Do a check of the battery terminals.                                                                          |                       |                    | *                   |                    |
| Replace the oil in the eccentric element.                                                                     |                       |                    |                     | X                  |
| Replace the hydraulic oil.                                                                                    |                       |                    |                     | X                  |

| Engine maintenance, Honda                                        | Before use, each 10 h | After the first 20 h | Weekly, each 100 h | Yearly, each 300 h |
|------------------------------------------------------------------|-----------------------|----------------------|--------------------|--------------------|
| Do a check of the fuel level and the engine oil level.           | X                     |                      |                    |                    |
| Clean the cooling fins of the engine.                            | O                     |                      |                    |                    |
| Examine the air filter. Clean the air filter if it is necessary. | X                     | X                    |                    |                    |
| Clean the air filter.                                            |                       |                      | X                  |                    |



| <b>Engine maintenance, Honda</b>                                                                              | <b>Before use,<br/>each 10 h</b> | <b>After the<br/>first 20 h</b> | <b>Weekly,<br/>each 100 h</b> | <b>Yearly, each<br/>300 h</b> |
|---------------------------------------------------------------------------------------------------------------|----------------------------------|---------------------------------|-------------------------------|-------------------------------|
| Do a check of the drain valve for the air filter. Only applicable for engines that have a cyclone precleaner. | ○                                |                                 |                               |                               |
| Replace the engine oil.                                                                                       |                                  | X                               | X                             | X                             |
| Replace the air filter.                                                                                       |                                  |                                 |                               | X                             |
| Do a check of the engine speed.                                                                               |                                  | ○                               | ○                             | ○                             |
| Examine and clean the spark plug. Replace the spark plug if it is necessary.                                  |                                  |                                 | ○                             |                               |
| Replace the spark plug.                                                                                       |                                  |                                 |                               | ○                             |
| Clean the fuel valve of the carburetor.                                                                       |                                  |                                 | ○                             | ○                             |
| Clean the spark arrester screen on the muffler.                                                               |                                  |                                 | ○                             | ○                             |
| Adjust the valve head clearance for the air intake and the exhaust valves.                                    |                                  | ○                               |                               | ○                             |
| Drain the fuel and clean the fuel tank and the fuel filter.                                                   |                                  |                                 |                               | ○                             |
| Clean and adjust the carburetor.                                                                              |                                  |                                 |                               | ○                             |
| Replace the fuel filter.                                                                                      |                                  |                                 |                               | ○                             |

| <b>Engine maintenance, Hatz</b>                                                                               | <b>Before use,<br/>each 10 h</b> | <b>After the<br/>first 20 h</b> | <b>Each 250 h</b> | <b>Yearly, each<br/>500 h</b> |
|---------------------------------------------------------------------------------------------------------------|----------------------------------|---------------------------------|-------------------|-------------------------------|
| Do a check of the fuel level and the engine oil level.                                                        | X                                |                                 |                   |                               |
| Clean the cooling fins of the engine.                                                                         | ○                                |                                 | ○                 | ○                             |
| Clean the air filter.                                                                                         | X                                | X                               |                   |                               |
| Replace the air filter.                                                                                       |                                  |                                 | X                 | X                             |
| Do a check of the drain valve for the air filter. Only applicable for engines that have a cyclone precleaner. | ○                                |                                 |                   |                               |
| Replace the engine oil.                                                                                       |                                  | X                               | X                 | X                             |
| Do a check of the engine speed.                                                                               |                                  | ○                               | ○                 | ○                             |
| Clean the spark arrester screen on the muffler.                                                               |                                  |                                 | ○                 | ○                             |
| Adjust the valve head clearance for the air intake and the exhaust valves.                                    |                                  | ○                               | ○                 | ○                             |
| Clean the oil filter.                                                                                         |                                  |                                 |                   | ○                             |
| Do a check of the fuel injection pump.                                                                        |                                  |                                 | ○                 | ○                             |
| Do a check of the fuel injection nozzle.                                                                      |                                  |                                 | ○                 | ○                             |
| Drain water from the fuel system.                                                                             |                                  |                                 |                   | ○                             |
| Replace the fuel filter.                                                                                      |                                  |                                 |                   | ○                             |

## To clean the product



**CAUTION:** Before you clean the product, attach a plastic bag tightly around the fuel tank cap. This is to make sure that water does not go into the venthole in the fuel tank cap.

- Use running water from a hose or a high-pressure washer to clean the product.



**CAUTION:** Do not point the water directly at the fuel tank cap, electrical components or the engine.

- Remove grease and oil from the handle.

## To do a general inspection

- Make sure that all nuts and screws on the product are tightened correctly.

## To do a check of the safety straps

1. Examine the safety straps at the front and the rear of the product.

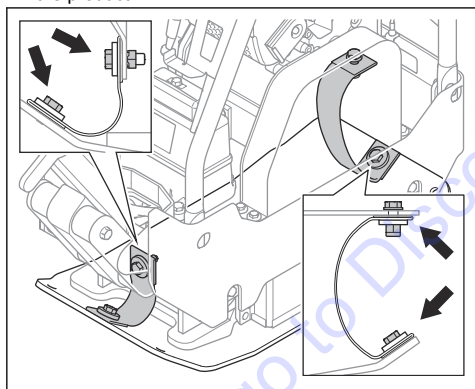

2. Examine the screws and nuts on the safety straps.
3. Replace damaged safety straps.
4. Replace damaged nuts and screws.
5. Tighten loose screws and nuts.

## To do a check of the engine oil level

1. Remove the oil tank cap and dipstick.
2. Clean the oil from the dipstick.
3. Put the dipstick back fully into the oil tank.
4. Remove the dipstick.
5. Examine the oil level on the dipstick.
6. If the oil level is low, fill with engine oil and do a check of the oil level again. Refer to *Technical data on page 25* or the engine manual for the correct type of oil.

## To replace the engine oil (LG 164, Honda)

If the engine is cold, start the engine for 1–2 minutes before you drain the engine oil. This makes the engine oil warm and easier to drain.



**WARNING:** Engine oil is very hot directly after the engine stops. Let the engine become cool before you drain the engine oil. If you spill engine oil on your skin, clean with soap and water.

1. Put a container below the drain plug for the engine oil.
2. Remove the oil drain plug (A) and connect a hose (B).

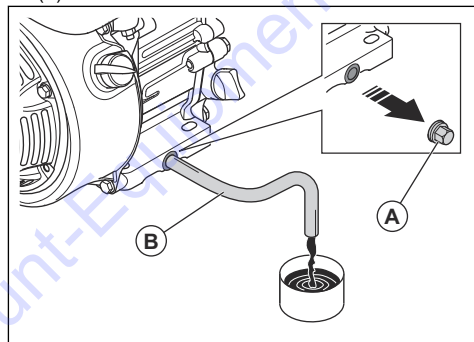

3. Tilt the product and let the oil run out into the container.
4. Remove the hose.
5. Install the oil drain plug and tighten it.
6. Fill with new engine oil. Refer to *Technical data on page 25* or the engine manual for the correct type of oil.
7. Do a check of the engine oil level.

## To replace the engine oil (LG 164, Hatz)

If the engine is cold, start the engine for 1–2 minutes before you drain the engine oil. This makes the engine oil warm and easier to drain.



**WARNING:** Engine oil is very hot directly after the engine stops. Let the engine become cool before you drain the engine oil. If you spill engine oil on your skin, clean with soap and water.

1. Put a container below the oil drain plug (A) or (B).

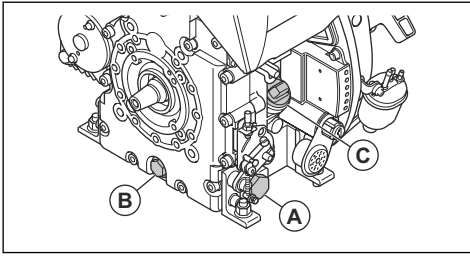

2. Remove the oil drain plug (A) or (B) and connect a hose.
3. Tilt the product and let the oil run out into the container.
4. Remove the hose.
5. Install the oil drain plug and tighten it.
6. Remove the dipstick (C) and fill with new engine oil. Refer to the engine manual for the correct type of oil.
7. Do a check of the engine oil level.

## Air filter



**WARNING:** Use approved respiratory protection when you clean or replace the air filter. Discard used air filters correctly. The dust in the air filter is dangerous to your health.



**CAUTION:** Always replace a damaged air filter, or the dust will go into the engine and cause engine damage.

### To clean or replace the air filter (LG 164, Honda)



**WARNING:** Do not clean the air filter with compressed air. This causes damage to the air filter and the risk increases that you breathe the dangerous dust.

1. Turn the knob on the air filter cover and remove the air filter cover.

2. Remove the paper filter element and the foam filter element (A).

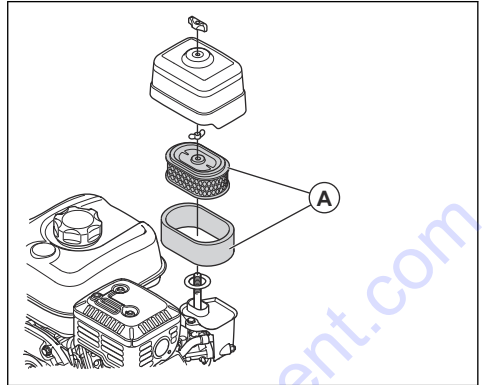

3. Clean the air filter housing with a brush.
4. Examine the air filter elements for damage.
5. Tap the paper filter element against a hard surface or use a vacuum cleaner to remove the particles.



**CAUTION:** Do not let the nozzle of the vacuum cleaner touch the surface of the paper filter element. Keep a small distance. The sensitive surface of the paper filter element becomes damaged if objects touch it.

6. Clean the foam filter element with a solution of soap and water.
7. Flush the foam filter element in clean water.
8. Compress the foam filter element to remove the water and let the foam filter element dry fully.
9. Lubricate the foam filter element with engine oil.
10. Push a clean cloth against the foam filter element to remove unwanted oil.
11. Install the air filter in the opposite sequence.

### To clean or replace the air filter (LG 164, Hatz)



**WARNING:** Do not clean the air filter with compressed air. This causes damage to the air filter and the risk increases that you breathe the dangerous dust.

1. Turn the knob on the air filter cover and remove the air filter cover.

- Remove the air filter (A).

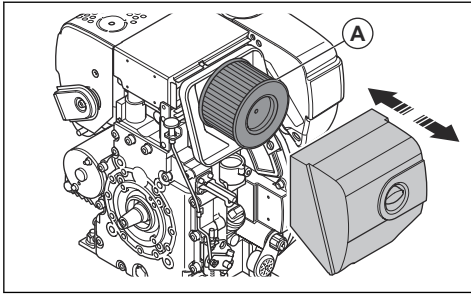

- Clean the air filter housing with a brush.
- Examine the air filter for damage.
- Tap the air filter against a hard surface or use a vacuum cleaner to remove the particles.



**CAUTION:** Do not let the nozzle of the vacuum cleaner touch the surface of the paper filter element. Keep a small distance. The sensitive surface of the paper filter element becomes damaged if objects touch it.

- Install the air filter in the opposite sequence.

### To do a check of the V-belt



**WARNING:** Do not operate the product without the V-belt cover installed.

- Stop the engine.
- Remove the V-belt cover.

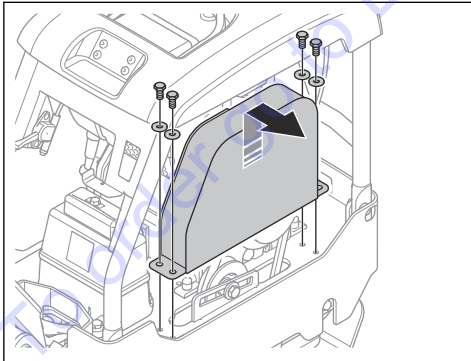

- Examine the V-belt for damages and wear. Replace the V-belt if it is necessary.

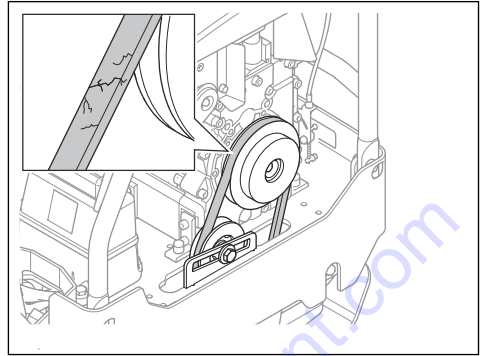

- Do a check of the V-belt tension.
- If the V-belt tension is not sufficient, do this procedure:

- Loosen the screw on the belt tensioner (A).

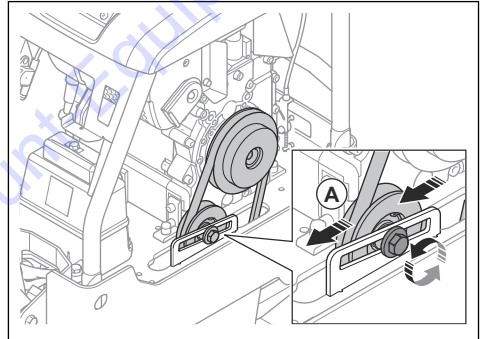

- Push the belt tensioner rearward.
- Tighten the screw on the belt tensioner.

- Install the V-belt cover.

### To replace the oil in the eccentric element

- Remove the oil drain plug for the eccentric element and connect a hose.

- LG 164:

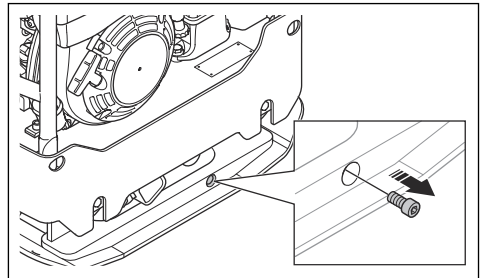

b) LG 204:

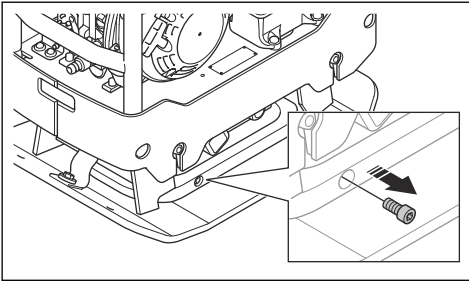

2. Tilt the product to drain the oil.

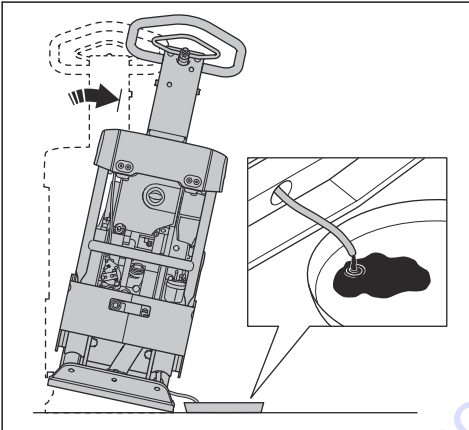

**Note:** You can also use a manual oil drain pump to drain the oil in the eccentric element.

3. Clean the surfaces around the hole for the oil drain plug, the threads of the hole and the oil drain plug. Use a dry cloth and, if it is necessary, an applicable solvent.



**CAUTION:** Do not use water to clean around and on the oil drain plug.

4. Fill the eccentric element with oil of the correct type. Refer to *Technical data* on page 25.

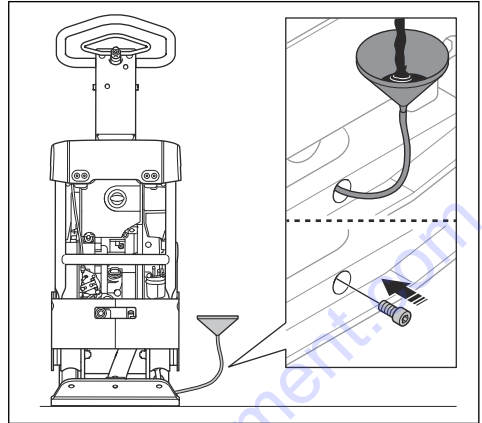

5. Install the oil drain plug.

## To do a check of the battery

1. Disconnect the battery cables (A).

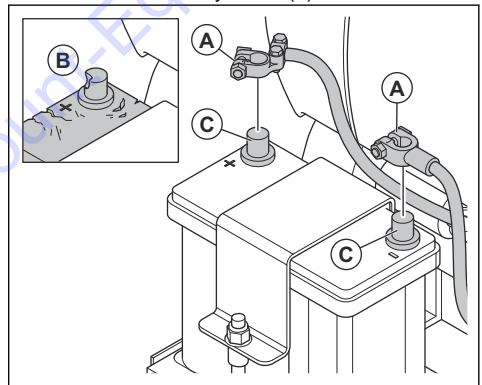

2. Examine the battery for damages (B). Replace the battery if it is damaged.

3. Clean the battery terminals (C).

4. Connect the battery cables.

## To charge the battery

- If the battery is not used for a long period of time, charge it fully before you use it.
- Use a battery charger that automatically adjusts the voltage. We recommend a 2-stage charger with constant voltage that automatically decreases to trickle charging when the battery is fully charged. Speak to Discount-equipment for information about the correct battery charger.
- Do a trickle charging 1-2 times during the winter season when the product is in storage.

## Hydraulic system

### To do a check of the hydraulic hoses

- Examine the hydraulic hoses regularly. Replace worn or damaged hydraulic hoses.



**WARNING:** Hydraulic oil is dangerous. The rubber in the hydraulic hoses wears with time. Worn or damaged hydraulic hoses can break and the hydraulic oil can cause injury. If you cannot tell if the hydraulic hoses are worn, always replace the hydraulic hoses.

### To do a check of the hydraulic oil level

1. Remove the dipstick from the hydraulic oil tank.

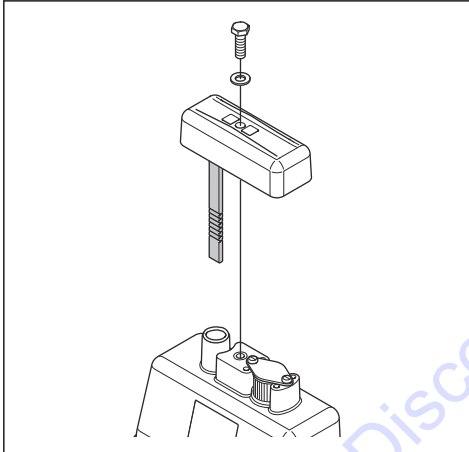

2. Read the hydraulic oil level on the dipstick.
3. If the hydraulic oil level is too low, let an approved service center examine the hydraulic system for leaks.

## To replace the hydraulic oil



**WARNING:** Risk of burn injury. The hydraulic oil becomes hot during operation of the product. Let the product become cool before you replace the hydraulic oil.

1. Remove the dipstick (A) from the hydraulic oil tank.

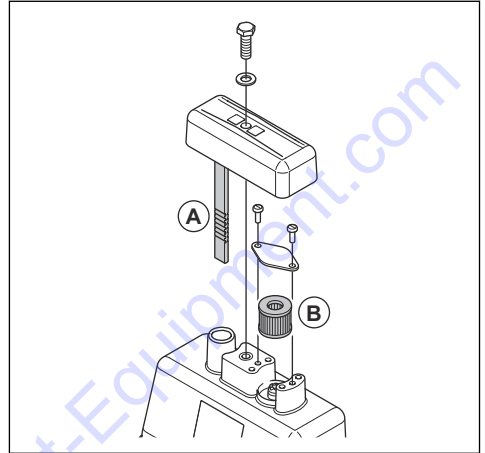

2. Use an oil drain pump to drain the hydraulic oil from the hydraulic oil tank.
3. Clean the opening of the hydraulic oil tank.
4. Replace the breather filter (B).
5. Fill with hydraulic oil of the correct type. Refer to *Technical data on page 25*.
6. Put the dipstick into the hydraulic oil tank.

## Transportation, storage and disposal

### Transportation



**WARNING:** Be careful during transportation. The product is heavy and can cause injury or damage if it falls or moves during transportation.

Transport wheels let you move the product manually for shorter distances. For longer distances, lift the product to move it or put the product on a vehicle.



**CAUTION:** Do not tow the product behind a vehicle.

## Trolley overview

The trolley is an optional accessory.

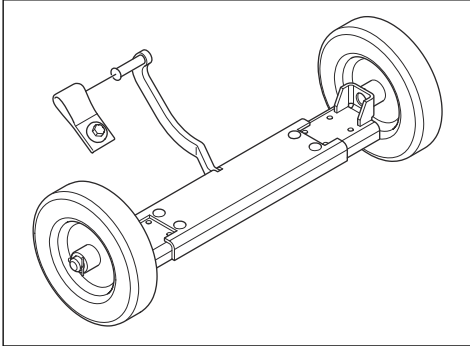

## To install the trolley on the product



**WARNING:** Do not put your hand between the trolley and the bottom plate. Risk of crush injury.

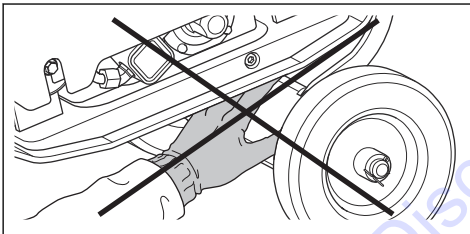

1. Adjust the width of the trolley to an applicable width for the product.

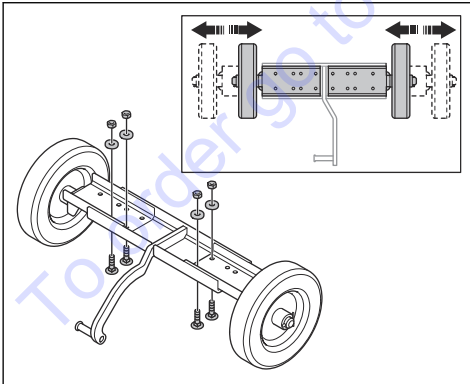

- a) Remove the screws, nuts and washers.
- b) Adjust the wheels.
- c) Install screws, nuts and washers and tighten the screws.

2. Attach the trolley strap to the product with the screw and washer.

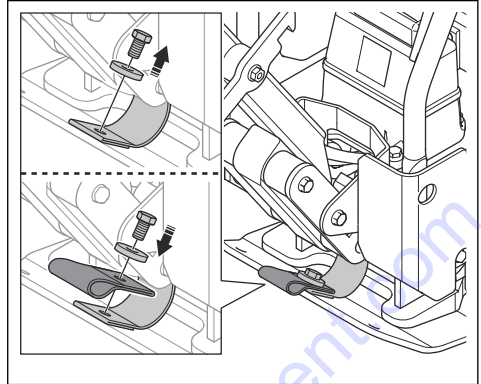

3. Put the hook of the trolley in the trolley strap.

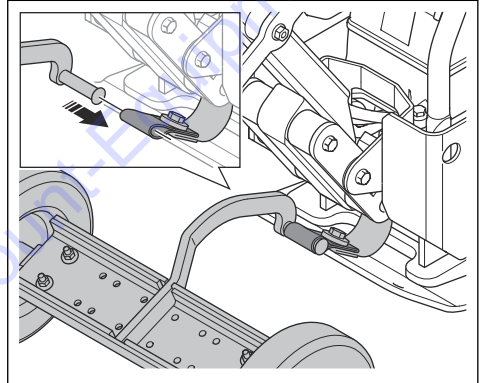

4. Lock the handle in upright position (A).

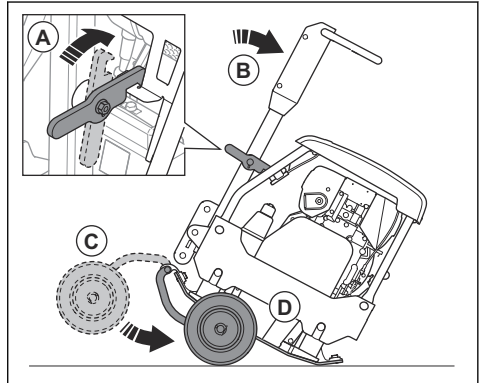

5. Tilt the product forward (B).
6. Fold the trolley (C) below the bottom plate (D).

7. Unlock the handle (A) and tilt the product rearward.

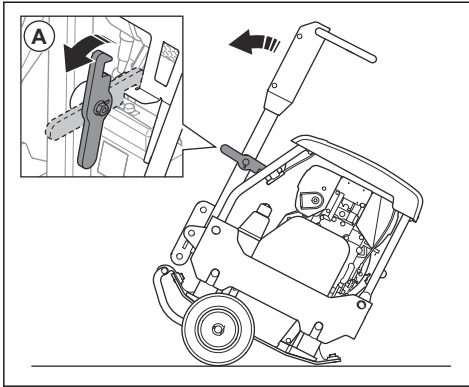

8. Move the product on the wheels.

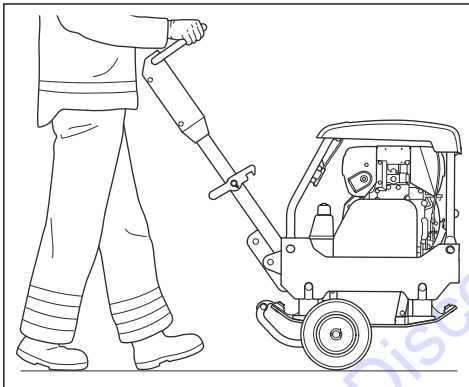

### To lift the product



**WARNING:** Make sure that the lifting equipment has the correct specification to lift the product safely. The type plate on the product shows the product weight.



**WARNING:** Do not lift a damaged product. Make sure that the lifting eye, the vibration damping units and the safety straps are correctly installed and not damaged.



**WARNING:** Do not walk or stay below or near a lifted product.

1. Lock the handle in upright position.

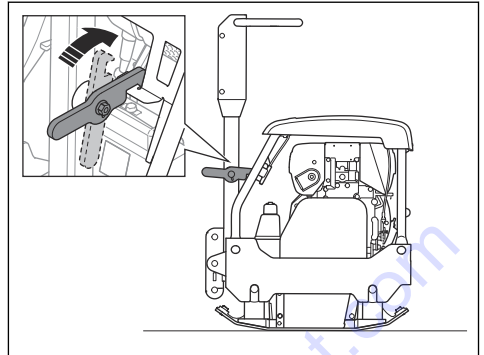

2. Attach the lifting equipment to the lifting eye. A label on the product identifies the correct position.

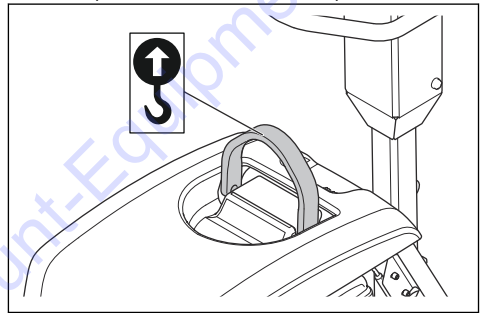

**WARNING:** Do not use metal hooks, chains or other lifting equipment with rough edges that can cause damage to the lifting eye.

### To safety the product to a transportation vehicle with tie-down straps

1. Lock the handle in upright position (A).

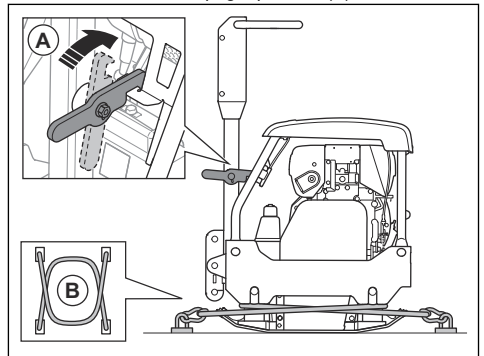

2. Put 2 straps (B) around the bottom plate.



- a) Put 1 strap around the front of the bottom plate and attach the strap to the vehicle.
- b) Put 1 strap around the rear of the bottom plate and attach the strap to the vehicle.

## Storage

- Remove all fuel from the fuel tank before you put the product in storage for a long period of time. Discard the fuel at an applicable disposal location.
- Fully charge the battery before storage. An empty battery freezes at approximately  $-7^{\circ}\text{C}/19^{\circ}\text{F}$ . A fully charged battery freezes at approximately  $-67^{\circ}\text{C}/89^{\circ}\text{F}$ .
- Clean the product before storage. Remove oil and dust from the rubber parts.
- Clean the air filter before storage.
- Carefully pull the starter rope handle until there is a small resistance.
- Put a protective cover on the product.
- Keep the product in a dry and frost free area.
- Keep the product in a locked area to prevent access for children or persons that are not approved.

## Disposal

- Chemicals can be dangerous and must not be discarded on the ground. Always discard used chemicals at a service center or an applicable disposal location.
- When the product is worn out, send it to the dealer or to an applicable recycling location.
- Oil, oil filters, fuel and the battery can have negative effects on the environment. Obey the local recycling requirements and applicable regulations.
- Do not discard the battery as domestic waste.
- Discard it at a disposal location for used batteries.

## Technical data

### Technical data (LG 164)

| LG 164                                             | Honda, manual start                 | Hatz, manual start                                          |
|----------------------------------------------------|-------------------------------------|-------------------------------------------------------------|
| Net weight, kg/lb                                  | 350 mm: 147/324<br>450 mm: 156/344  | 350 mm: 165/364<br>450 mm: 168/370<br>600 mm: 184/406       |
| Operation weight (EN500, incl. oil, ½ fuel), kg/lb | 350 mm: 148/326<br>450 mm: 157/346  | 350 mm: 166/366<br>450 mm: 169.5/373.7<br>600 mm: 185/407.9 |
| Engine brand, type                                 | Honda, GX160                        | Hatz, 1B20                                                  |
| Engine power, kW/hp @rpm <sup>1</sup>              | 3.6/4.8 @3600                       | 3.1/4.3 @3200                                               |
| Vibration frequency, Hz/rpm                        | 80/4800                             | 80/4800                                                     |
| Amplitude, mm/in.                                  | 1.4/0.054                           | 1.4/0.054                                                   |
| Centrifugal force, kN/lbf                          | 28/6.3                              | 28/6.3                                                      |
| Operation speed, m/min / ft./min                   | 22/72                               | 22/72                                                       |
| Max. tilt, degrees/%                               | 20/36                               | 25/47                                                       |
| Fuel tank capacity, l/qts                          | 3.1/3.3                             | 3.6/3.8                                                     |
| Engine oil capacity *, l/qts                       | 0.6/0.63                            | 0.9/0.95                                                    |
| Hydraulic fluid, l/qts                             | 1/1.1                               | 1/1.1                                                       |
| Eccentric element, l/qts                           | 0.4/0.42                            | 0.4/0.42                                                    |
| Fuel consumption, l/h or qts/h                     | 0.95 or 0.25                        | 0.87 or 0.19                                                |
| Engine oil *                                       | SAE 10W-30, API Class SJ            | SAE 10W-30, API Class SJ                                    |
| Eccentric element oil                              | SAE 10W-30, API Class SJ            | SAE 10W-30, API Class SJ                                    |
| Hydraulic oil                                      | Shell Tellus S3 V 32                | Shell Tellus S3 V 32                                        |
| Biological hydraulic oil (optional)                | Shell Naturelle HF-E 32             | Shell Naturelle HF-E 32                                     |
| Fuel *                                             | Unleaded gasoline, max. 10% ethanol | Ultra-low-sulfur diesel fuel only                           |

\* = For further information and questions about this specific engine, refer to the engine manual or the web site of the engine manufacturer.

<sup>1</sup> As specified by the engine manufacturer. The power rating of the engine indicated is the average net output (at specified rpm) of a typical production engine for the engine model measured to SAE standard J1349/ISO1585. Mass production engines may differ from this value. Actual power output for the engine installed on the final product will depend on the operating speed, environmental conditions and other values.

| Noise and vibration emissions, LG 164                                   | Honda                        | Hatz                                     |
|-------------------------------------------------------------------------|------------------------------|------------------------------------------|
| Sound power level, measured dB (A)                                      | 102                          | 104                                      |
| Sound power level, guaranteed $L_{WA}$ dB (A) <sup>2</sup>              | 108                          | 108                                      |
| Sound pressure level at the operator's ear, $L_P$ , dB (A) <sup>3</sup> | 350 mm: 81.9<br>450 mm: 82.4 | 350 mm: 84.1<br>450 mm: 84<br>600 mm: 93 |
| Vibration level, $a_{hv}$ , $m/s^2$ <sup>4</sup>                        | 2.3                          | 3.5                                      |

## Technical data (LG 204)

| LG 204                                             | Honda, manual start | Hatz, manual start | Hatz, electric start                     |
|----------------------------------------------------|---------------------|--------------------|------------------------------------------|
| Net weight, kg/lb                                  | 209.4/461.6         | 225.7/497.6        | 500 mm: 241.8/553.1<br>600 mm: 249/549   |
| Operation weight (EN500, incl. oil, ½ fuel), kg/lb | 210.8/464.7         | 227.7/502.0        | 500 mm: 243.8/537.5<br>600 mm: 251/553.4 |
| Engine brand, type                                 | Honda, GX 200       | Hatz, 1B20         | Hatz, 1B20                               |
| Engine power, kW/hp @rpm <sup>5</sup>              | 4.1/5.5 @3600       | 3.1/4.2 @3100      | 3.1/4.2 @3100                            |
| Vibration frequency, Hz/rpm                        | 65/3900             | 65/3900            | 65/3900                                  |
| Amplitude, mm/in.                                  | 1.9/0.07            | 1.9/0.07           | 500 mm: 1.9/0.07<br>600 mm: 1.7/0.06     |
| Centrifugal force, kN/lbf                          | 36/8093             | 36/8093            | 36/8093                                  |
| Operation speed, m/min or ft./min                  | 23 or 75.5          | 22 or 72.2         | 22 or 72.2                               |
| Max. tilt, degrees/%                               | 20/36               | 25/47              | 25/47                                    |
| Battery voltage, V                                 | –                   | –                  | 12                                       |
| Battery capacity, Ah                               | –                   | –                  | 41                                       |
| Fuel tank capacity, l/qts                          | 3.1/3.3             | 3.6/3.8            | 3.6/3.8                                  |

<sup>2</sup> Noise emissions in the environment measured as sound power ( $L_{WA}$ ) as per EN ISO 3744 in conformity with EC directive 2000/14/EC. The difference between guaranteed and measured sound power is that the guaranteed sound power also includes dispersion in the measurement result and the variations between different machines of the same model according to Directive 2000/14/EC.

<sup>3</sup> Sound pressure level  $L_P$  according to EN ISO 11201, EN 500-4. Uncertainty  $K_{PA}$  4.0 dB (A).

<sup>4</sup> Vibration value according to EN 500-4. Reported data for vibration level has a typical statistical dispersion (standard deviation) of 1.5  $m/s^2$ .

<sup>5</sup> As specified by the engine manufacturer. The power rating of the engine indicated is the average net output (at specified rpm) of a typical production engine for the engine model measured to SAE standard J1349/ISO1585. Mass production engines may differ from this value. Actual power output for the engine installed on the final product will depend on the operating speed, environmental conditions and other values.

| LG 204                              | Honda, manual start                 | Hatz, manual start                | Hatz, electric start              |
|-------------------------------------|-------------------------------------|-----------------------------------|-----------------------------------|
| Eccentric element, l/qts            | 0.5/0.53                            | 0.5/0.53                          | 0.5/0.53                          |
| Engine oil *                        | SAE 10W-30, API Class SJ            | SAE 10W-30, API Class SJ          | SAE 10W-30, API Class SJ          |
| Eccentric element oil               | SAE 10W-30, API Class SJ            | SAE 10W-30, API Class SJ          | SAE 10W-30, API Class SJ          |
| Hydraulic oil                       | Shell Tellus S3 V 32                | Shell Tellus S3 V 32              | Shell Tellus S3 V 32              |
| Biological hydraulic oil (optional) | Shell Naturelle HF-E 32             | Shell Naturelle HF-E 32           | Shell Naturelle HF-E 32           |
| Fuel *                              | Unleaded gasoline, max. 10% ethanol | Ultra-low-sulfur diesel fuel only | Ultra-low-sulfur diesel fuel only |

\* = For further information and questions about this specific engine, refer to the engine manual or the web site of the engine manufacturer.

| Noise and vibration emissions, LG 204                                   | Honda | Hatz | Hatz, electric start       |
|-------------------------------------------------------------------------|-------|------|----------------------------|
| Sound power level, measured dB (A)                                      | 104   | 105  | 105                        |
| Sound power level, guaranteed $L_{WA}$ dB (A) <sup>6</sup>              | 106   | 108  | 108                        |
| Sound pressure level at the operator's ear, $L_p$ , dB (A) <sup>7</sup> | 84    | 90   | 500 mm: 85.1<br>600 mm: 93 |
| Vibration level, $a_{hv}$ , $m/s^2$ <sup>8</sup>                        | 3.5   | 3.4  | 500 mm: 3.4<br>600 mm: 2.8 |

## Noise and vibration declaration statement

These declared values were obtained by laboratory type testing in accordance with the stated directive or standards and are suitable for comparison with the declared values of other products tested in accordance with the same directive or standards. These declared values are not suitable for use in risk assessments and values measured in individual work places may be higher. The actual exposure values and risk of harm experienced by an individual user are unique and depend upon the way the user works, in what material the product is used, as well as upon the exposure time and the physical condition of the user, and the condition of the product.

<sup>6</sup> Noise emissions in the environment measured as sound power ( $L_{WA}$ ) as per EN ISO 3744 in conformity with EC directive 2000/14/EC. The difference between guaranteed and measured sound power is that the guaranteed sound power also includes dispersion in the measurement result and the variations between different machines of the same model according to Directive 2000/14/EC.

<sup>7</sup> Sound pressure level  $L_p$  according to EN ISO 11201, EN 500-4. Uncertainty  $K_{PA}$  4.0 dB (A).

<sup>8</sup> Vibration value according to EN 500-4. Reported data for vibration level has a typical statistical dispersion (standard deviation) of 1.5  $m/s^2$ .

## Product dimensions (LG 164)

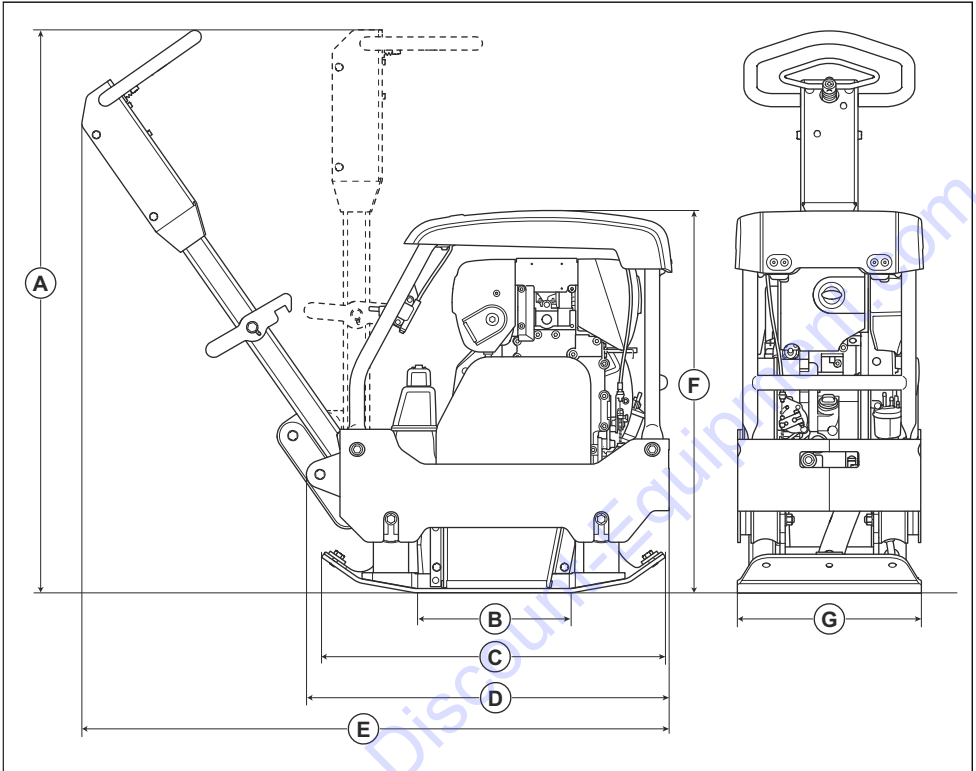

|          |                                                    |                         |          |                                 |                                  |
|----------|----------------------------------------------------|-------------------------|----------|---------------------------------|----------------------------------|
| <b>A</b> | Handle height, mm/in.                              | 1069/42                 | <b>E</b> | Length including handle, mm/in. | 1110/44                          |
| <b>B</b> | Bottom plate contact area, m <sup>2</sup> /sq. ft. | 0.103/1.11 / 0.132/1.42 | <b>F</b> | Height, mm/in.                  | 727/28.6                         |
| <b>C</b> | Length bottom plate, mm/in.                        | 654/25.7                | <b>G</b> | Width, mm/in.                   | 350/13.8 or 450/17.7 or 600/23.6 |
| <b>D</b> | Length with handle folded, mm/in.                  | 748/29.4                |          |                                 |                                  |

## Product dimensions (LG 204)

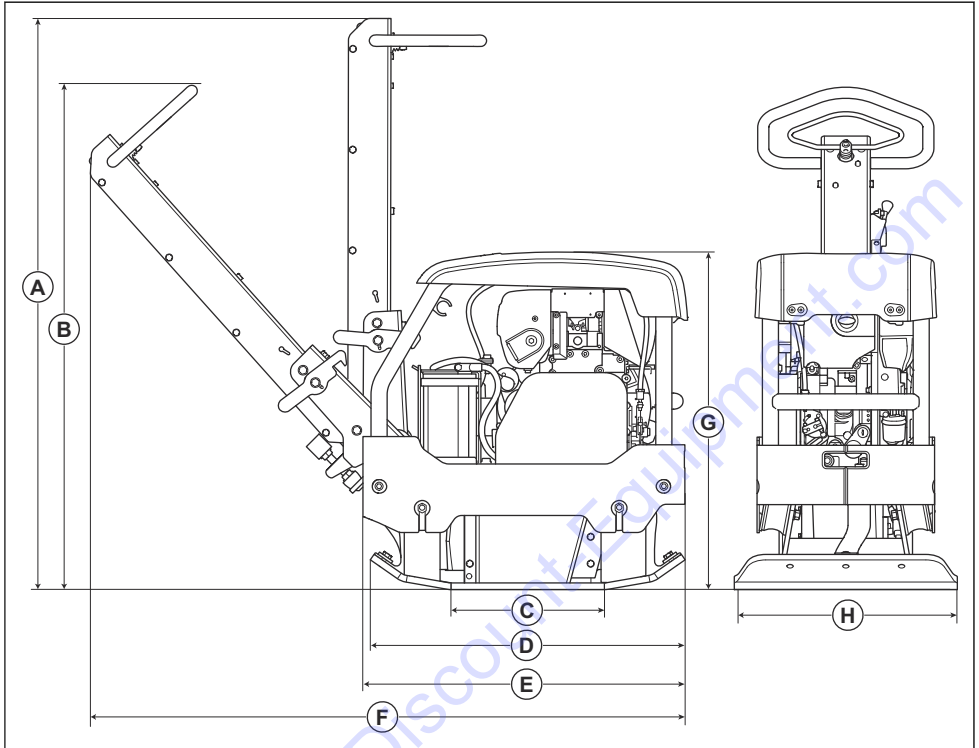

|          |                                                    |               |          |                                   |                      |
|----------|----------------------------------------------------|---------------|----------|-----------------------------------|----------------------|
| <b>A</b> | Handle height, transport position, mm/in.          | 1269/50.0     | <b>E</b> | Length with handle folded, mm/in. | 720/28.3             |
| <b>B</b> | Handle height, operation position, mm/in.          | 1126/44.3     | <b>F</b> | Length including handle, mm/in.   | 1328/52.3            |
| <b>C</b> | Bottom plate contact area, m <sup>2</sup> /sq. ft. | 0.1735/1.8675 | <b>G</b> | Height, mm/in.                    | 754/29.7             |
| <b>D</b> | Length bottom plate, mm/in.                        | 703/27.7      | <b>H</b> | Width, mm/in.                     | 500/19.7 or 600/23.6 |

**TO PURCHASE THIS PRODUCT PLEASE CONTACT US**



**Equipment Financing and  
Extended Warranties Available**



**Discount-Equipment.com is your online resource for  
commercial and industrial quality parts and equipment sales.**

**561-964-4949**

**visit us on line @ [www.discount-equipment.com](http://www.discount-equipment.com)**

Select an option below to find your Equipment

**Search by Manufacturer**

**Search by Product Type**

**Request a Quote**

We sell worldwide for the brands: Genie, Terex, JLG, MultiQuip, Mikasa, Essick, Whiteman, Mayco, Toro Stone, Diamond Products, Generac Magnum, Airman, Haulotte, Barreto, Power Blanket, Nifty Lift, Atlas Copco, Chicago Pneumatic, Allmand, Miller Curber, Skyjack, Lull, Skytrak, Tsurumi, Husquvarna Target, Stow, Wacker, Sakai, Mi-T-M, Sullair, Basic, Dynapac, MBW, Weber, Bartell, Bennar Newman, Haulotte, Ditch Runner, Menegotti, Morrison, Contec, Buddy, Crown, Edco, Wyco, Bomag, Laymor, EZ Trench, Bil-Jax, F.S. Curtis, Gehl Pavers, Heli, Honda, ICS/PowerGrit, IHI, Partner, Imer, Clipper, MMD, Koshin, Rice, CH&E, General Equipment, Amida, Coleman, NAC, Gradall, Square Shooter, Kent, Stanley, Tamco, Toku, Hatz, Kohler, Robin, Wisconsin, Northrock, Oztec, Toker TK, Rol-Air, APT, Wylie, Ingersoll Rand / Doosan, Innovatech, Con X, Ammann, Mecalac, Makinex, Smith Surface Prep, Small Line, Wanco, Yanmar

 **Husqvarna**®



Original instructions

1140387-26



2020-03-05