

Operating Instructions

Control unit WSE1217 ★★★ USA

Index 000

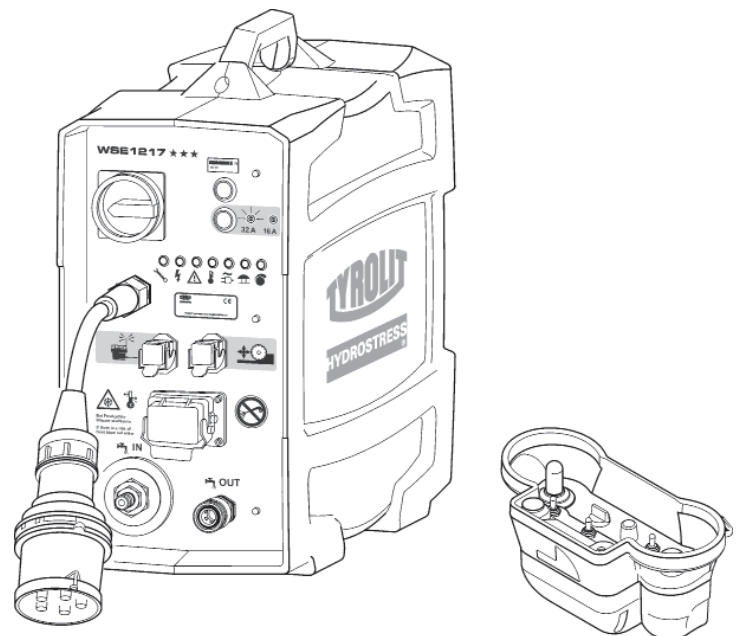

TO PURCHASE THIS PRODUCT PLEASE CONTACT US



**Equipment Financing and
Extended Warranties Available**



**Discount-Equipment.com is your online resource for
commercial and industrial quality parts and equipment sales.**

561-964-4949

visit us on line @ www.discount-equipment.com

Select an option below to find your Equipment

Search by Manufacturer

Search by Product Type

Request a Quote

We sell worldwide for the brands: Genie, Terex, JLG, MultiQuip, Mikasa, Essick, Whiteman, Mayco, Toro Stone, Diamond Products, Generac Magnum, Airman, Haulotte, Barreto, Power Blanket, Nifty Lift, Atlas Copco, Chicago Pneumatic, Allmand, Miller Curber, Skyjack, Lull, Skytrak, Tsurumi, Husquvarna Target, Stow, Wacker, Sakai, Mi-T-M, Sullair, Basic, Dynapac, MBW, Weber, Bartell, Bennar Newman, Haulotte, Ditch Runner, Menegotti, Morrison, Contec, Buddy, Crown, Edco, Wyco, Bomag, Laymor, EZ Trench, Bil-Jax, F.S. Curtis, Gehl Pavers, Heli, Honda, ICS/PowerGrit, IHI, Partner, Imer, Clipper, MMD, Koshin, Rice, CH&E, General Equipment, Amida, Coleman, NAC, Gradall, Square Shooter, Kent, Stanley, Tamco, Toku, Hatz, Kohler, Robin, Wisconsin, Northrock, Oztec, Toker TK, Rol-Air, APT, Wylie, Ingersoll Rand / Doosan, Innovatech, Con X, Ammann, Mecalac, Makinex, Smith Surface Prep, Small Line, Wanco, Yanmar

Congratulations!

With a Hydrostress unit from TYROLIT, you have chosen a tried and tested piece of equipment which has been designed and built to leading technical standards. Only genuine TYROLIT Hydrostress replacement parts can guarantee quality and interchangeability. If maintenance work is neglected or carried out inexpertly we will be unable to honour our warranty obligations. Any repair work must be carried out by trained personnel only.

Our after sales service is available to help ensure that your TYROLIT Hydrostress units remain in perfect working order.

We hope that working with your TYROLIT unit will be a satisfying and fault-free experience.

TYROLIT Hydrostress

1 Safety



DANGER

Failure to comply with the safety instructions in the «Safety Manuals / System Handbooks» may result in serious injuries or even death.

- ▶ Make sure that the «Safety Manuals / System Descriptions» for the relevant type of saw have been fully read and understood.



DANGER

Death or serious injury can be caused by sudden start-up of the machine.

- ▶ Before switching on the system, ensure that no other persons are present in the danger areas.
- ▶ Switch the system off before connecting or disconnecting cables.
- ▶ Switch the system off when you leave and secure it so that it cannot be switched back on again.

Death or serious injury as a result of the sawing machine continuing to run after an accident.

- ▶ Ensure that the EMERGENCY STOP button can be reached quickly.

Electric shock from live cables and connectors.

- ▶ Switch off the control unit WSE1217 ★★★ before connecting or disconnecting cables.
- ▶ Ensure that the power supply is earthed and fitted with a residual current operated protective device (FI) with a maximum residual current of 30mA.

Risk of fire due to incorrect mains voltage.

- ▶ Make sure that the mains voltage and mains frequency match control unit mains settings WSE1217 ★★★.

1.1 In case of emergency

- ▶ Press the EMERGENCY STOP button on the remote controller.

If the EMERGENCY STOP is activated on the radio remote controller, the LED warning light flashes rapidly.



In an emergency the sawing machine can be also switched off using the main switch on the control unit WSE1217 ★★★.

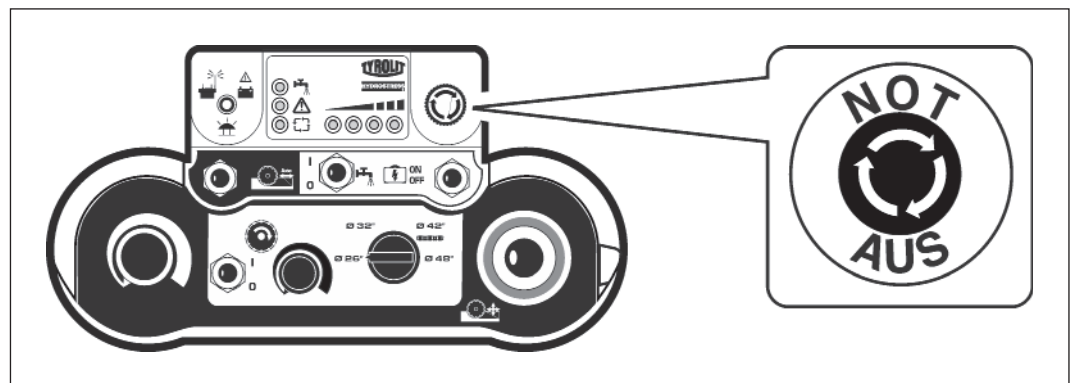

EMERGENCY STOP

2 Description

2.1 Main components control unit

Main components control unit

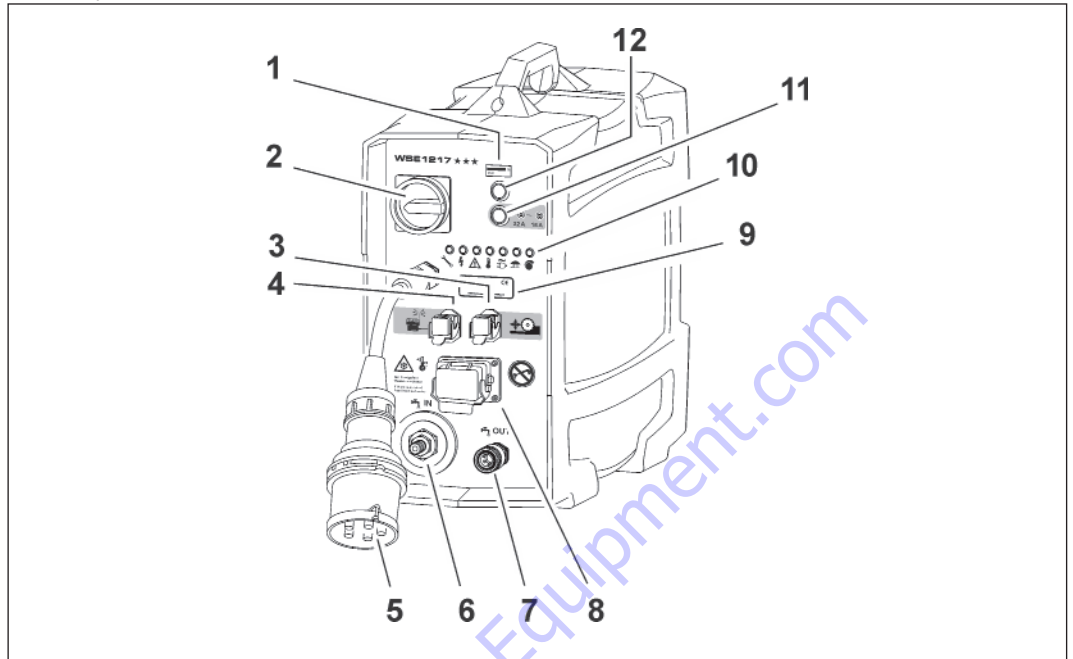

- | | |
|--------------------------------|-----------------------------------|
| 1 Operating hours counter | 7 Water connection / water outlet |
| 2 Main switch | 8 Main motor connection |
| 3 Feed motor connection | 9 Name plate |
| 4 Remote controller connection | 10 Indicator lights |
| 5 Mains connector | 11 Mains system selection button |
| 6 Water nipple / water inlet | 12 Reset button |

2.2 Main components remote controller

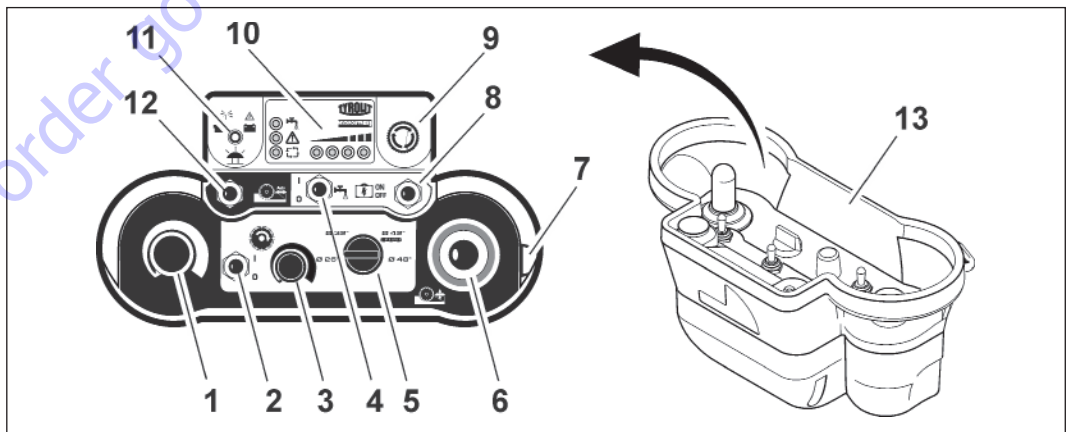

Main components remote controller

- | | |
|----------------------------|---|
| 1 Feed potentiometer | 8 Pulse switch Control unit |
| 2 On / Off main motor | 9 EMERGENCY STOP |
| 3 Main motor potentiometer | 10 Indicator lights |
| 4 Water On / Off | 11 Warning light (radio & battery) |
| 5 Diameter selector switch | 12 Position lock switch (Traverse feed) |
| 6 Traverse feed joystick | 13 Casing |
| 7 Starter switch | |

2.3 Remote controller



The remote controller can be replaced by an accumulator or a battery operated radio remote controller. Additionally the remote controller can be operated using a cable.

Radio remote control

The transmitter and receiver are a pair of matched units. They cannot be used with other devices.

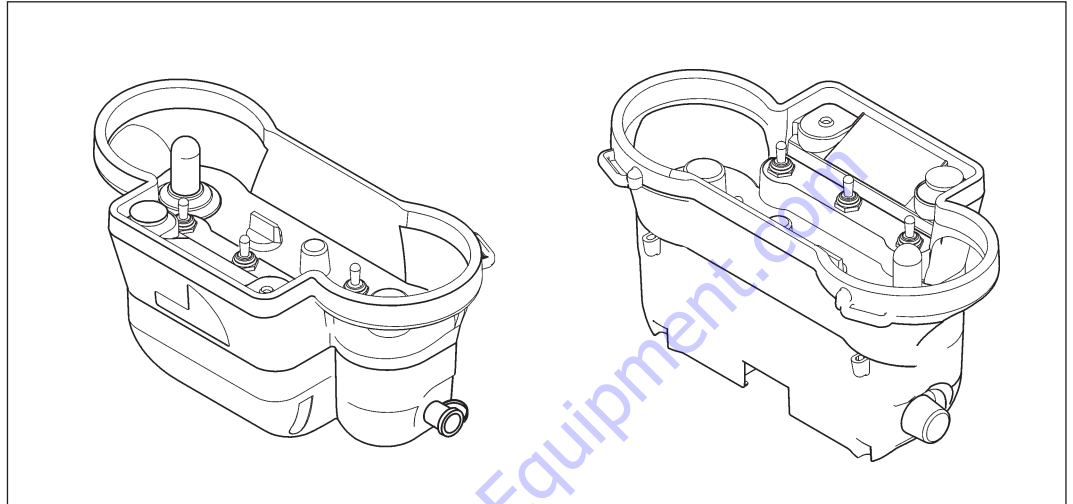

2.4 Operating modes

Rechargeable battery operation:

The interchangeable rechargeable battery is inserted in the base of the casing. The operating period with a fully charged battery is approximately 12 hours. The reception distance is 27 yards.

Battery operation:

The battery holder included in the scope of supply allows operation with three 1.5 V AA batteries. The reception distance is 27 yards.

Cable operation:

The cable insert included in the scope of supply allows connection of the remote controller to the control unit WSE1217★★★. The cable length is 11 yards. Cable operation makes it possible to work in areas where radio operation is not allowed (e.g. hospitals).

With cable operation all control signals are transmitted via the power cable. The rechargeable/ordinary battery holders may not be inserted in the base of the casing during cable operation.

2.5 Accessories Remote control



The battery charger is exclusively for recharging the interchangeable rechargeable battery. The battery holder and the cable insert must not be inserted.

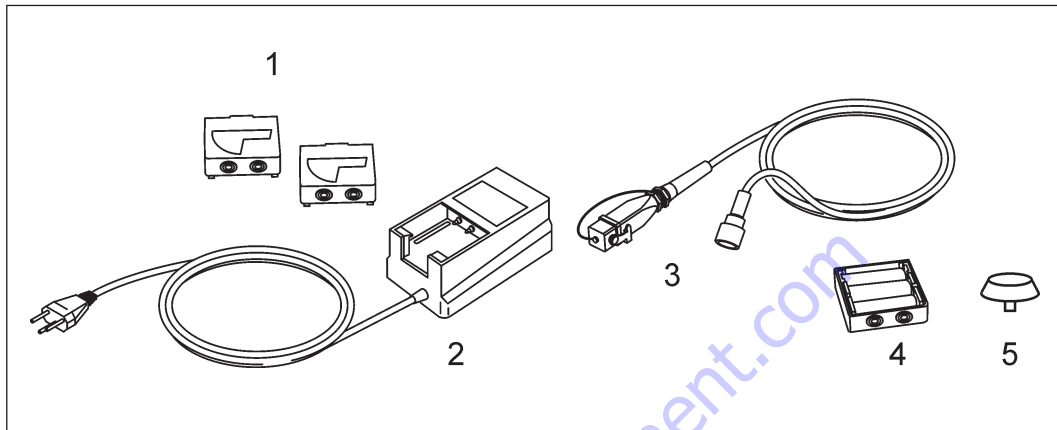

Accessories

- | | | |
|---|--|--------------|
| 1 | 2x Interchangeable rechargeable batteries | No. 10984306 |
| 2 | Rechargeable battery charger | No. 10984305 |
| | Rechargeable battery charger with 10-30 VDC connection | No.10984840 |
| 3 | Remote control cable | No. 10991362 |
| 4 | Battery holder | No. 10984307 |
| 5 | Key | No. 10984309 |

To order go to DiscountEquipment.com

3 Connections

3.1 Making remote control and motor connections

- ✓ The control unit is isolated from the power supply
- ✓ Connectors/plugs are clean
- ✓ Cables are undamaged

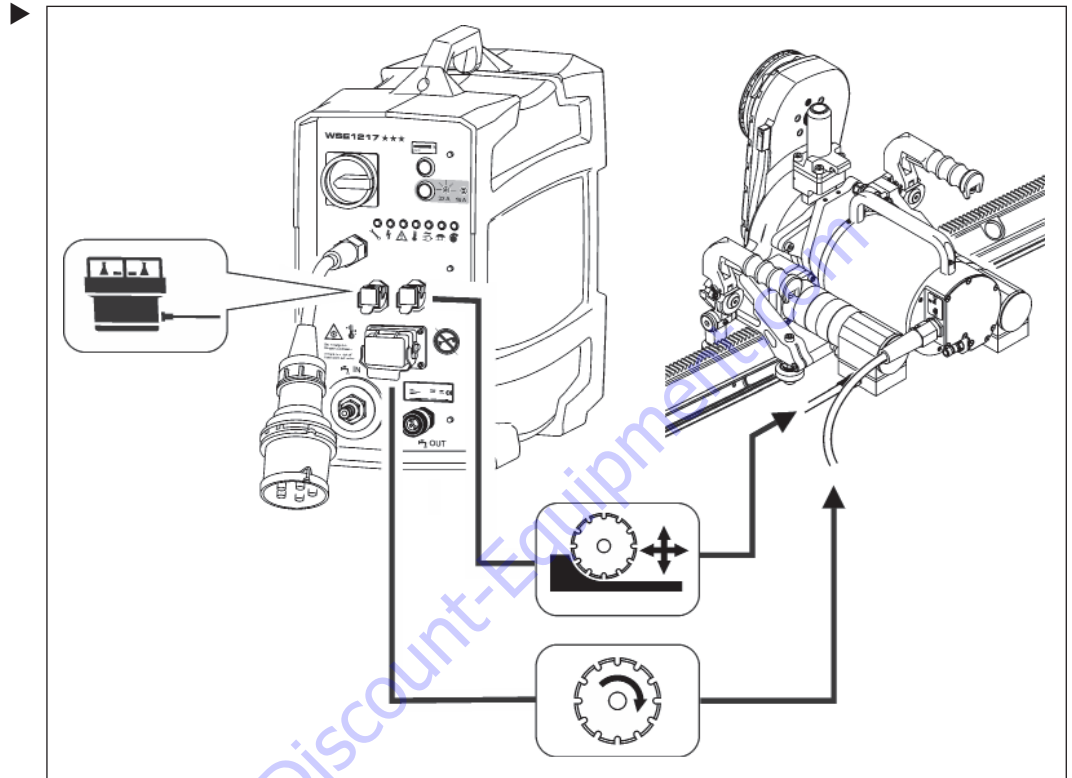

3.2 Making the mains connection and water supply

- ✓ The power supply is earthed and fitted with a residual current operated protective device (FI; max. residual current 30mA)
- ✓ Cable cross-section is sufficient: for up to 27 yards long 5 x AWG 11, more than 27 yards long 5 x AWG 9.

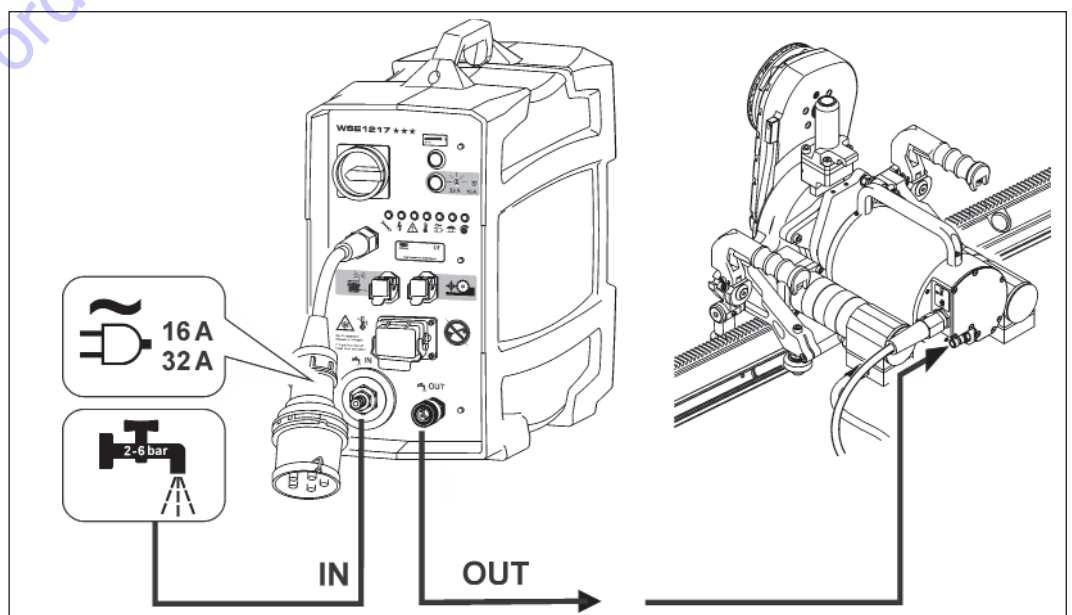

4 Operation

4.1 Overview of operating elements

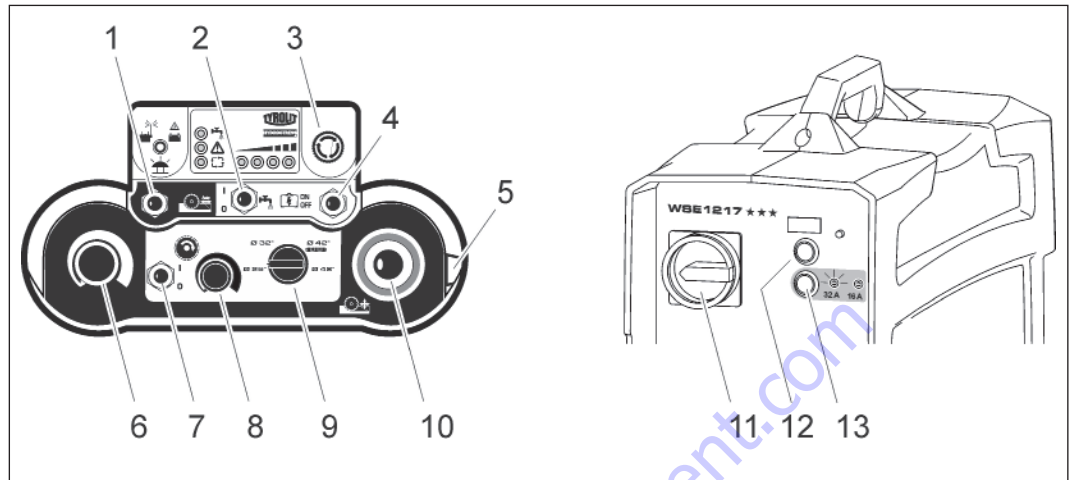

Operating elements

- | | |
|--|----------------------------------|
| 1 Position lock switch (Traverse feed) | 8 Main motor potentiometer |
| 2 Water On / Off | 9 Diameter selector switch |
| 3 EMERGENCY STOP | 10 Traverse feed joystick |
| 4 Pulse switch Control unit | 11 Main switch Control unit |
| 5 Starter switch | 12 Reset button |
| 6 Feed potentiometer | 13 Mains system selection button |
| 7 On / Off Main motor | |



The control unit WSE1217*** can also be used for wire sawing and core drilling with suitable TYROLIT Hydrostress system components.

Wire sawing:

To change to the control unit WSE1217 wire sawing mode*** the rotary switch (9) (diameter selector switch) is turned to the symbol wire sawing.

4.2 Starting the control unit WSE1217★★★



CAUTION

The control unit WSE1217★★★ can be damaged if it slips or overturns!

- ▶ Make sure that the control unit WSE1217★★★ stands horizontally (handle at top).
- ✓ Control unit WSE1217★★★ is connected to the mains and the water supply.
- ✓ The sawing machine is connected to the control unit WSE1217★★★.
(see «Operating instructions - Sawing machine »)
- ✓ The remote control EMERGENCY STOP has been deactivated.

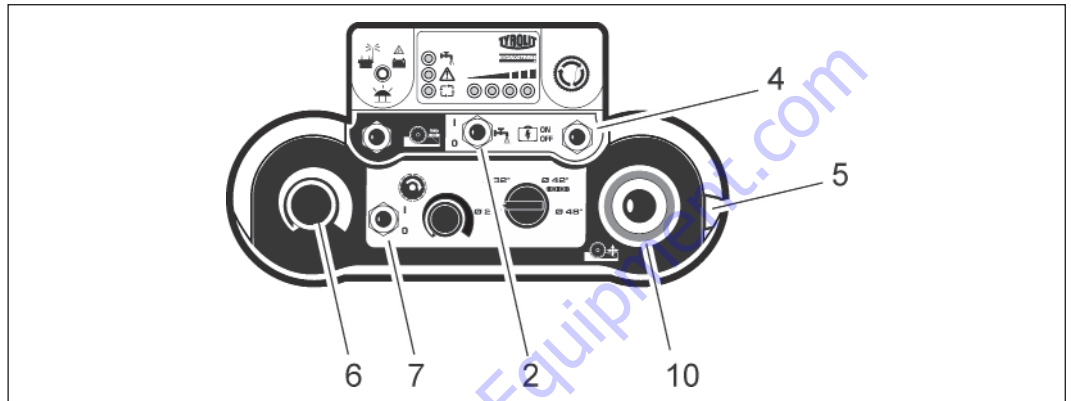

Starting the control unit WSE1217★★★

- ▶ Move the controls shown below on the remote controller to the 0 position.

Feed potentiometer (6)

Starter switch (5)

Feed joy stick (10)

Main motor On/Off (7)

- ▶ Switch on the control unit WSE1217★★★ using the main switch (11).

- ▶ Switch on the radio remote controller using the starter switch (5).

- Warning lights (radio and battery) at first show red
- An audible signal sounds simultaneously
- Indicators flash coloured
- Second audible signal sounds
- Indicators show coloured
- Warning light flashes green

- ▶ Press the remote control pulse switch (4) briefly in the ON-position.
All indicator lights except the warning lights and the group alarm on the remote controller go off.
- ▶ Press the reset button (12) on the control unit.
- ▶ Press the remote control pulse switch (4) briefly in the ON-position.
The the control unit 'ready' lights show green.
- ▶ Open the water valve on the system supply line.
- ▶ Press the Water On/Off switch (2) on the remote control unit to I.
– Water flows from the cutting tool
- ▶ Press the main motor On/Off switch (7) on the remote controller to position I.
– The electric motor starts if the main motor potentiometer is at the max. position.
- ▶ The control unit WSE1217★★★ has started and ready for operation.

4.3 Select mains network



The control unit WSE1217★★★ is preset for a 32 A power supply network. (32A Button lights up). It is possible to switch over to a 16 A power supply network. The system automatically returns to the 32 A settings when it is restarted.

- ▶ To set the power supply network to 16 A press the power network selector (13), the button light goes out.
Resetting must take place directly after switching on the control unit WSE1217★★★.

4.4 Tool soft start

The control unit WSE1217★★★ offers the possibility for a tool soft start. The soft start is particularly applicable in the case of diamond wire saws.

Proceed as follows:

- ▶ Start the control unit WSE1217★★★, see 4.2.
- ▶ Turn the main motor (8) potentiometer to the 0 position.
- ▶ Press the switch main motor (7) to I.
- ▶ Select the desired output level, see 4.5.
- ▶ Turn the main motor (8) potentiometer slowly to 100% power.

4.5 Select tool station

After the control unit WSE1217★★★ has been started correctly the tool station can be selected.

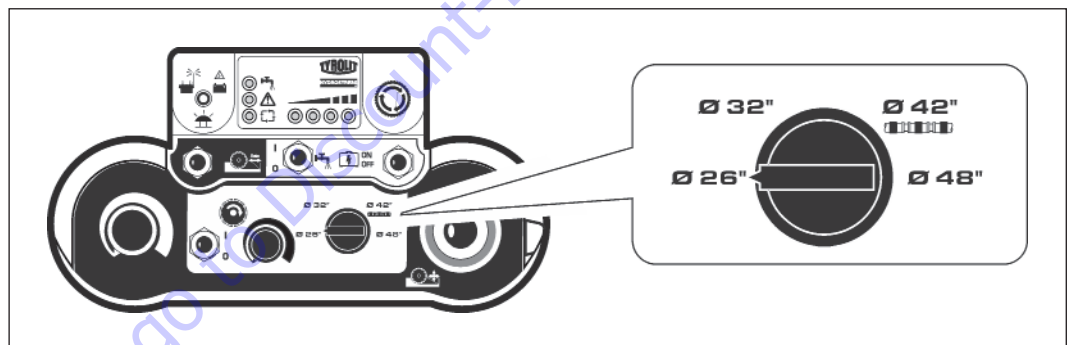

Selecting the power level

Proceed as follows:

- ▶ Set the diameter selector switch to the desired tool and turn the main motor potentiometer from 0 to 100%.



The tool stations may not be changed during operation.

The tool stations are set with reference to the tool diameter for the optimum rotational speed and cutting performance.

The rotational speed can be reduced using the main motor potentiometer but at the same time the power is reduced.

4.6 Power control

The main motor and the feed motor power are controlled via the potentiometers.

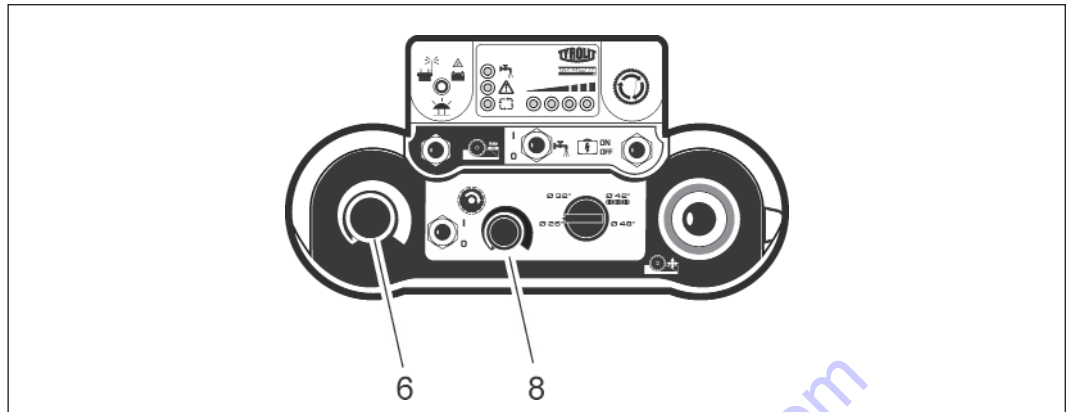

Power control

Feed motor potentiometer (6)

Main motor potentiometer (8)

4.7 Adjusting the feed

The feed movements are selected with the joystick.

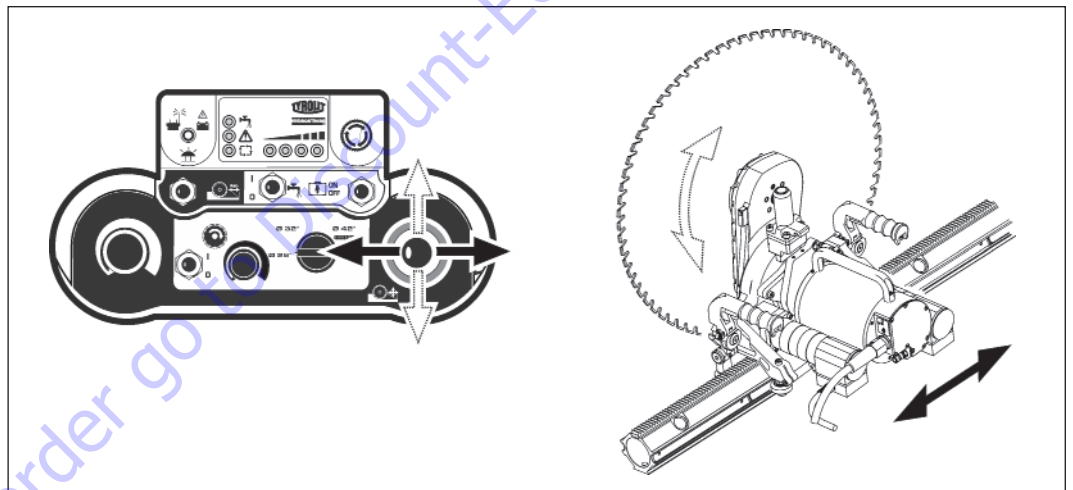

Adjusting the feed

During the cutting process the feed speed is automatically assisted by a feed facility.

4.7.1 Manually adjusting the feed speed

- ✓ Control unit WSE1217★★★ has been started
- ▶ Select the required feed speed via the feed potentiometer (6).

4.7.2 Feed stop

So that the joystick does not have to be held in position during the travel feed motion the travel feed can be locked.

Proceed as follows:

- ▶ Push the joystick in the desired travel direction and at the same time press the locking switch (1).
- ▶ When the joystick and the locking switch are released the feed is locked.



In order to release the feed lock, move the joystick slightly in any desired direction.

4.8 Switching off the control unit WSE1217★★★

Proceed as follows:

- ▶ Switch off electric motor (7) On / Off Main motor.
- ▶ Turn off cooling water, switch (2) Water On / Off.
- ▶ Close water valve on control unit WSE1217★★★.
- ▶ Turn the start switch (5) on the remote controller to the 0 position.
- ▶ Switch on the control unit WSE1217★★★ using the main switch (11).



CAUTION

Frost damage to control unit WSE1217★★★!

- ▶ Blow out any water if there is a risk of frost (see chapter 4.9, Blowing out water).



Stop the wall saw WSE1217★★★ only in an emergency using the EMERGENCY STOP function.

4.9 Blowing out the water

- ✓ Main switch is set to **OFF**
- ▶ Disconnect the mains plug.
- ▶ Disconnect all water lines.
- ▶ Connect blow out pump to the water nipple.
- ▶ Blow out water until all of the cooling water has been removed.
- ▶ Remove the pump.

4.10 Deactivating EMERGENCY STOP

If the EMERGENCY STOP is activated on the radio remote controller, the radio and battery light (8) flash.

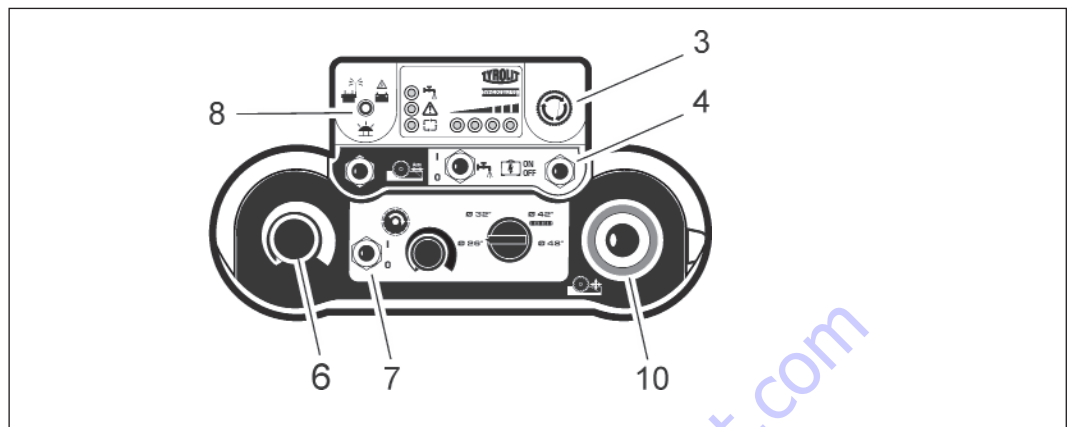

Deactivating EMERGENCY STOP

The following controls must be moved the 0 position:

- Feed potentiometer (6).
- Feed joy stick (10).
- Main motor On/Off (7).
- Turn the EMERGENCY STOP button (3) clockwise.
- Press pulse switch control unit (4) to the ON position.

4.11 After termination of work

Proceed as follows:

- ▶ Turn the main switch on the control unit WSE1217★★★ to the 0-position.
- ▶ Withdraw the mains plug (control unit WSE1217★★★).
- ▶ Disconnect the water hoses on control unit WSE1217★★★.
- ▶ Blow out the water from all the lines (blow out pump).
- ▶ Disconnect electric cable.
- ▶ Clean the control unit WSE1217★★★, the remote controller and the cable with a damp cloth.

Cleaning using high pressure cleaning equipment is not permitted.



Products containing cleaning agent can damage parts of the control unit WSE1217★★★, the radio remote controller and the cable.

5 Responding to displays

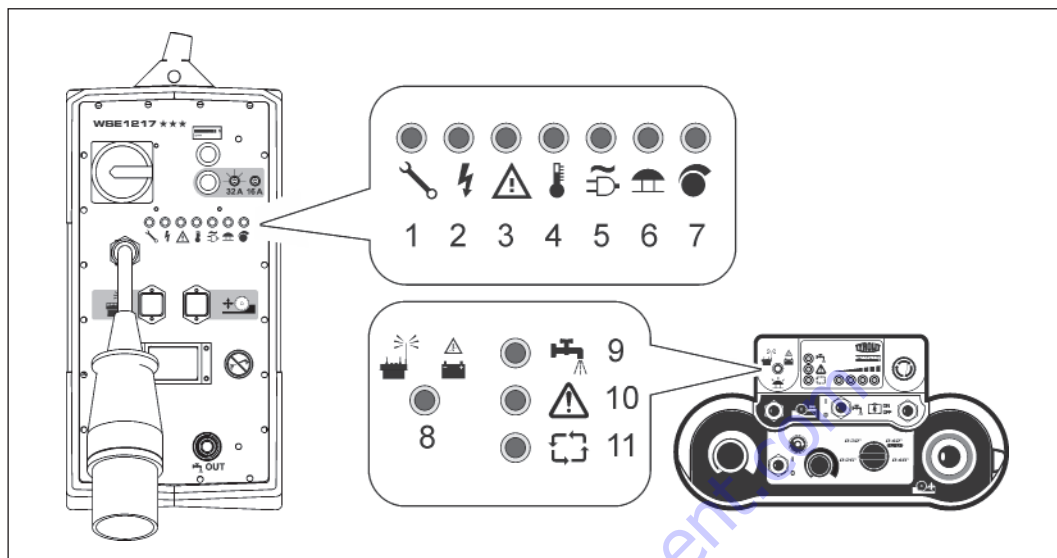







Symbols on the control unit / remote controller





Symbols on the control unit

- 1 Service
- 2 Fault within the control unit
- 3 Control unit external fault
- 4 Temperature
- 5 Mains connector
- 6 EMERGENCY STOP
- 7 Potentiometers

Symbols on the remote controller

- 8 Radio and battery remote control
- 9 Cooling water
- 10 Group alarm
- 11 Ready for operation lights

Power and error displays on the control unit			
Symbol	Response	Possible cause	Action
	Lights up red	After the first 100 operating hours, then after every 200 operating hours.	Carried out only by TYROLIT Hydrostress AG or an authorised representative
	Lights up red	Fault: - current overload - short circuit - earth fault Main motor - defective feed motor	The control unit will not start. ▶ Check network connection. ▶ Check cable. ▶ Replace feed motors. ▶ Contact TYROLIT Hydrostress AG customer service.
	Lights up red	Defective : - main contactor - brake resistance - over current Motor - CAN fault - group fault	The control unit will not start. ▶ Contact TYROLIT Hydrostress AG customer service. ▶ Check network connection.
	Lights up red	Overheated: - cooling element - control unit - main motor	The control unit will not start. ▶ Check cooling. Wait until it can be restarted. Before starting press the reset button. (Water cooling see page 19) ▶ Avoid direct contact with sun light.
	Lights up red	Phase missing	The drive unit will not start or switches off during operation.
			▶ Check the mains fuse in the distribution box and switch it on if necessary.
			▶ Have the site power supply checked.
		▶ Have the extension cables, plugs and sockets checked for faults.	
	Lights up red	The EMERGENCY STOP has been activated - CAN fault	▶ Deactivate the EMERGENCY STOP. ▶ Contact TYROLIT Hydrostress AG customer service.
	Lights up red	Feed potentiometer not in zero position	The control unit will not start. ▶ Set the feed potentiometer to 0 .

Power and error displays on the remote controller			
Symbol	Response	Possible cause	Action
	Flashes red	Rechargeable battery voltage too low	▶ Recharge rechargeable battery.
	Flashes rapidly green	No radio connection The EMERGENCY STOP has been activated	▶ Switch on the control unit. ▶ Defective receiver. ▶ No receiver matched connection, see page 5.
	No light shows	No water flow	The control unit will start, but motor does not run. ▶ Press the cooling water button (LED shows blue).
	Lights up red or flashes	<ul style="list-style-type: none"> • Group alarm on the control unit • On operating the pulse switch control unit the main motor On/Off switch is in the position On 	▶ Observe control unit fault indicators. ▶ Press the control unit reset button.
	Lights up green	The motor is ready to start	
	No light shows	Contacteur not ready	▶ Operate control unit pulse switch.
		Shows the current power range Ideally: At the third, orange coloured diode (in iron fourth, red diode).	

To order go to Discount-Equipment.com

5 Servicing and maintenance

Maintenance and servicing table		Before start- ing up	On finishing work	Weekly	Annually	After faults	After damage
Electrical system	▶ Check the condition and cleanliness of electric cables, plugs/connectors and switches.	X	X			X	X
	▶ Check the condition and cleanliness of connections.	X	X			X	X
Water supply	▶ Check water lines for cleanliness and leaks.	X	X			X	X
	▶ Blow out the water if there is a risk of frost.		X			X	X
Complete control unit WSE1217★★★	▶ Clean with damp cloth no high pressure cleaner		X				
Service	▶ To be performed by TYROLIT Hydros- tress AG or an authorised workshop.	First service after 100 operating hours Further services after every further 200 operating hours					



Cleaning using high pressure cleaning equipment is not permitted.

Cleaning using high pressure cleaning equipment can damage the control unit and the remote controller.

Products containing cleaning agent can damage parts of the control unit WSE1217★★★, the radio remote controller and the cable.

6 Faults

Faults		
Faults	Possible cause	Solution
Control unit does not run although the mains cable is connected	Control unit is switched off	▶ Switch control unit on, see Chapter 4.
	Mains cable is defective	▶ Replace the mains cable.
	No voltage at the power supply (building site)	▶ Check the power supply.
	Power supply phases incorrectly connected	▶ Check the power supply.
	Phase missing	See the chapter «Responding to displays».
The control unit starts and then switches off again	Building site power supply cut-off unit trips	▶ Check and if necessary adapt the cut-off protection. ▶ If necessary change the power supply. ▶ See chapter «Responding to displays».
No power, even though the control unit is running	Incorrect voltage Defective main motor	▶ Make sure that the control unit voltage and frequency match the mains supply specifications. ▶ Contact TYROLIT Hydrostress AG customer service.
The control unit suddenly switches off	Over or under voltage	▶ Check the power supply. Refer to fault indicator.
	Cross section of power supply cable too small	▶ Check the power supply.
	Defective plug connection	▶ Check the plug connection. ▶ Check the power supply.
	Group alarm	▶ Refer to fault indicator.
Main motor is not running	<ul style="list-style-type: none"> • Main motor potentiometer is in 0-position • Defective main motor On / Off switch on remote controller The remote controller 'ready to operate' light does not come on.	▶ Contact TYROLIT Hydrostress AG customer service. ▶ Do not start control unit, see Chapter 4.2
	EMERGENCY STOP activated	▶ Deactivate EMERGENCY STOP, see Chapter 4.10.
	Overheating	▶ Check the water circuit and the plug-in couplings. ▶ Refer to fault indicator.
	No water	▶ Switch on the water supply. ▶ Refer to fault indicator.
Remote controller not working	Rechargeable battery or battery have too little charge	▶ Replace rechargeable battery and recharge or install cable operation. ▶ Replace batteries.
Feed potentiometer indicates no function	<ul style="list-style-type: none"> • Defective potentiometer in the remote controller • Feed motors not connected • Defective feed motor • Joystick is in the zero position 	▶ Contact TYROLIT Hydrostress AG customer service. ▶ See Chapters 3.1 / 4.6 / 4.7
Feed motor fails to build up power	Remote controller potentiometer is defective or in the 0-position	▶ Contact TYROLIT Hydrostress AG customer service. ▶ See Chapter 4.7.1
	Defective cable	▶ Contact TYROLIT Hydrostress AG customer service.
	Motor fault	▶ Contact TYROLIT Hydrostress AG customer service.

Faults		
Faults	Possible cause	Solution
No water emerging	Water line blocked	▶ Clean the water line.
	Water valve on the supply or water hose are closed	▶ Open the water valve.
	Insufficient water pressure	▶ Make sure that the water pressure is at least 2 bar.
	Water filter is blocked	▶ Remove filter and clean ▶ Contact TYROLIT Hydrostress AG customer service.
	Switch for the radio remote controller defective	▶ Contact TYROLIT Hydrostress AG customer service.
Uncontrolled water leak	<ul style="list-style-type: none"> • Water valve on the control unit WSE1217 is defective • Switch for the radio remote control defective 	<ul style="list-style-type: none"> ▶ Stop water leaks using the hose water valve. ▶ Contact TYROLIT Hydrostress AG customer service.
Group alarm on the remote controller		▶ See chapter «Responding to displays».

To order go to [Discount-Equipment.com/](https://www.discount-equipment.com/)

7 Technical data

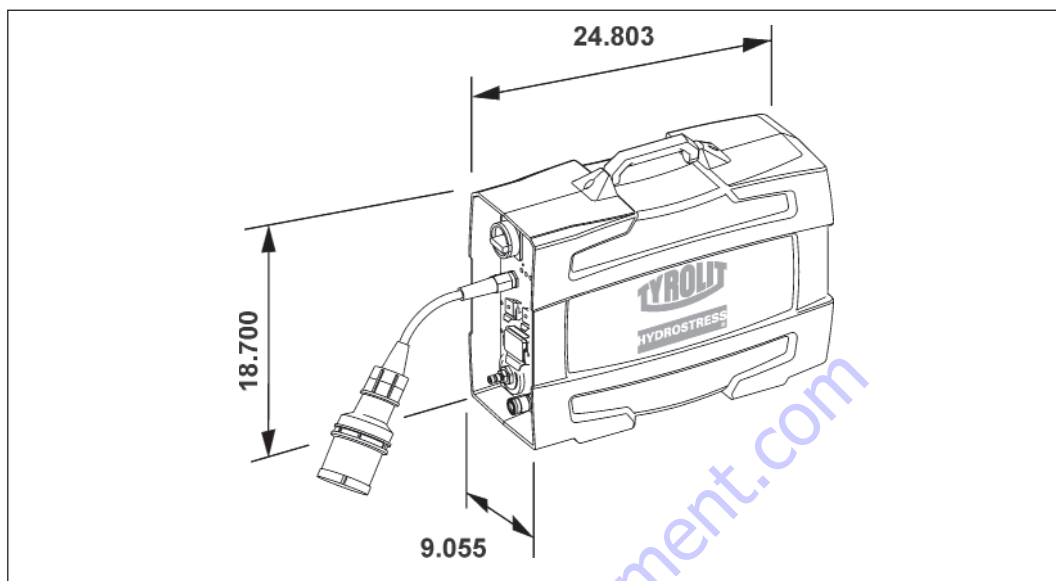

Dimensions in inch

Technical data		
Parameter	Value	
Weight	Control unit WSE1217 ★★★ incl. remote controller	48.5 lbs
	Remote controller separate	4.4 lbs
Protection class	IP 65	
Connection values	460 to 480 VAC / 60 Hz	
Power consumption	16 to 32 A (400 V/ 50 Hz)	
Power	at 16 A	8 kW
	at 32 A	17 kW
Internal control voltages	Computer / Remote controller	24 VDC
	Feed drives	48 VDC
	Main drive unit	400 VAC, 0..400 Hz
Water	Cooling the control unit	Water cooling the power semi-conductors
	Cooling water flow rate	min. 1.05 gmp at max 77°F
	Water connection	29 to 87 psi

8 EU Declaration of Conformity

Description	Control unit
Type designation	WSE1217★★★
Year of construction	2011

We declare under our sole responsibility that this product complies with the following directives and standards:

Applied directives

2006/42/EU	of 17th May 2006
2004/108/EU	of 15th December 2004
2002/96/EU	of 27th January 2003

Applied standards

EN 15027/A1	2009
EN 12100	2010
EN 60204-1/A1	2009
EN 6100-3-11	2000
EN 6100-3-12	2005
1999/5/EG	1999

TYROLIT Hydrostress AG

Witzbergstrasse 18
CH-8330 Pfäffikon
Switzerland

Pfäffikon, 28.04.2011



Pascal Schmid
Development leader



9 Spare parts

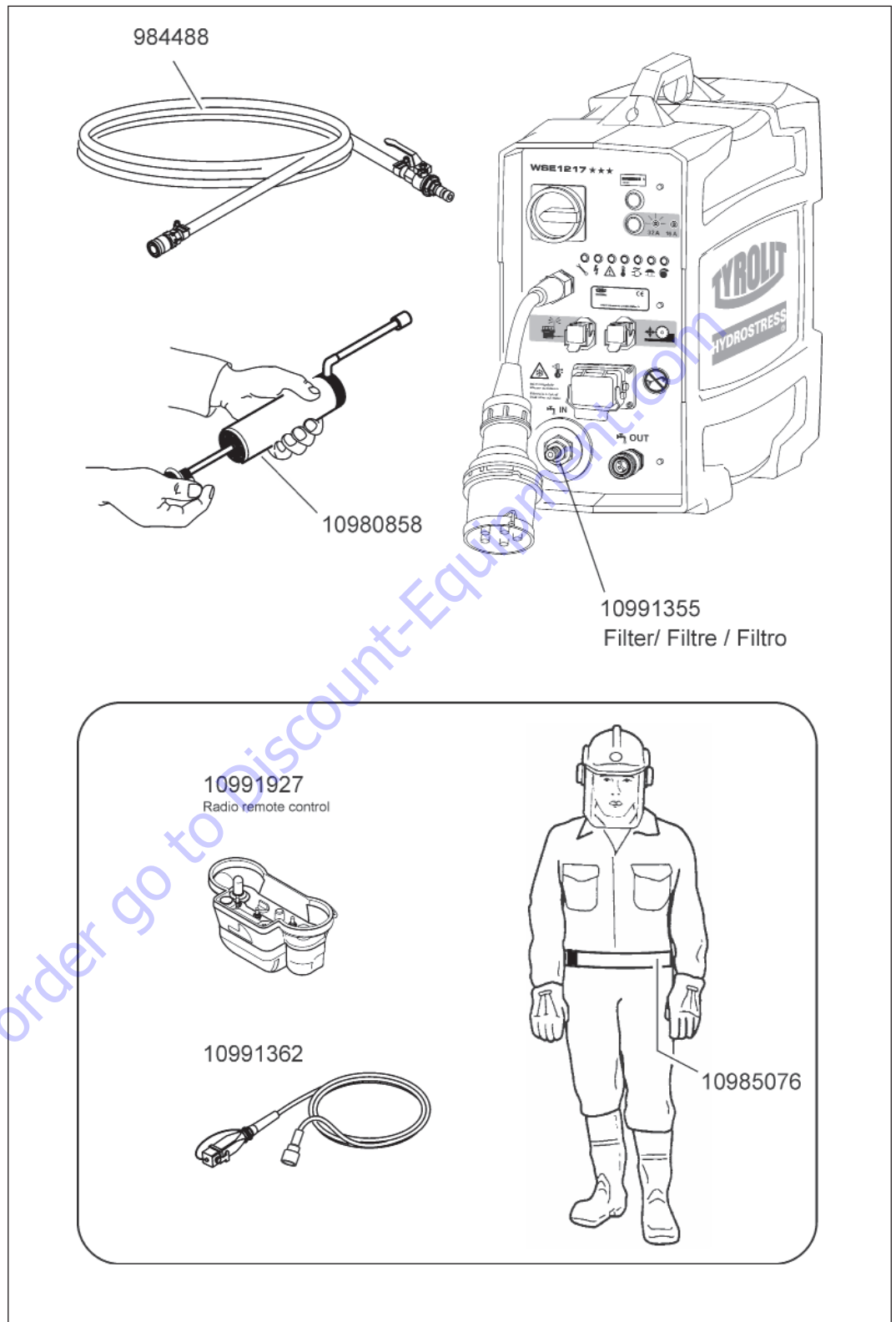

TO PURCHASE THIS PRODUCT PLEASE CONTACT US



**Equipment Financing and
Extended Warranties Available**



**Discount-Equipment.com is your online resource for
commercial and industrial quality parts and equipment sales.**

561-964-4949

visit us on line @ www.discount-equipment.com

Select an option below to find your Equipment

Search by Manufacturer

Search by Product Type

Request a Quote

We sell worldwide for the brands: Genie, Terex, JLG, MultiQuip, Mikasa, Essick, Whiteman, Mayco, Toro Stone, Diamond Products, Generac Magnum, Airman, Haulotte, Barreto, Power Blanket, Nifty Lift, Atlas Copco, Chicago Pneumatic, Allmand, Miller Curber, Skyjack, Lull, Skytrak, Tsurumi, Husquvarna Target, Stow, Wacker, Sakai, Mi-T-M, Sullair, Basic, Dynapac, MBW, Weber, Bartell, Bennar Newman, Haulotte, Ditch Runner, Menegotti, Morrison, Contec, Buddy, Crown, Edco, Wyco, Bomag, Laymor, EZ Trench, Bil-Jax, F.S. Curtis, Gehl Pavers, Heli, Honda, ICS/PowerGrit, IHI, Partner, Imer, Clipper, MMD, Koshin, Rice, CH&E, General Equipment, Amida, Coleman, NAC, Gradall, Square Shooter, Kent, Stanley, Tamco, Toku, Hatz, Kohler, Robin, Wisconsin, Northrock, Oztec, Toker TK, Rol-Air, APT, Wylie, Ingersoll Rand / Doosan, Innovatech, Con X, Ammann, Mecalac, Makinex, Smith Surface Prep, Small Line, Wanco, Yanmar



www.Discount-Equipment.com

To order go to Discount-Equipment.com