



# **OPERATING INSTRUCTIONS**

## **CONTROL UNIT WSE1621**

Index 000

To order go to [Discount-Equipment.com](http://Discount-Equipment.com)

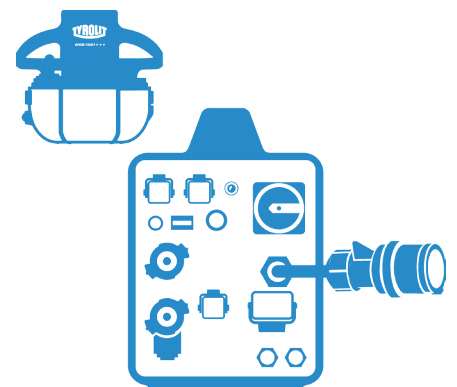

**TO PURCHASE THIS PRODUCT PLEASE CONTACT US**



**Equipment Financing and  
Extended Warranties Available**



**Discount-Equipment.com is your online resource for  
commercial and industrial quality parts and equipment sales.**

**561-964-4949**

**visit us on line @ [www.discount-equipment.com](http://www.discount-equipment.com)**

Select an option below to find your Equipment

**Search by Manufacturer**

**Search by Product Type**

**Request a Quote**

We sell worldwide for the brands: Genie, Terex, JLG, MultiQuip, Mikasa, Essick, Whiteman, Mayco, Toro Stone, Diamond Products, Generac Magnum, Airman, Haulotte, Barreto, Power Blanket, Nifty Lift, Atlas Copco, Chicago Pneumatic, Allmand, Miller Curber, Skyjack, Lull, Skytrak, Tsurumi, Husquvarna Target, Stow, Wacker, Sakai, Mi-T-M, Sullair, Basic, Dynapac, MBW, Weber, Bartell, Bennar Newman, Haulotte, Ditch Runner, Menegotti, Morrison, Contec, Buddy, Crown, Edco, Wyco, Bomag, Laymor, EZ Trench, Bil-Jax, F.S. Curtis, Gehl Pavers, Heli, Honda, ICS/PowerGrit, IHI, Partner, Imer, Clipper, MMD, Koshin, Rice, CH&E, General Equipment, Amida, Coleman, NAC, Gradall, Square Shooter, Kent, Stanley, Tamco, Toku, Hatz, Kohler, Robin, Wisconsin, Northrock, Oztec, Toker TK, Rol-Air, APT, Wylie, Ingersoll Rand / Doosan, Innovatech, Con X, Ammann, Mecalac, Makinex, Smith Surface Prep, Small Line, Wanco, Yanmar

## **Congratulations!**

You have decided to purchase a tried-and-tested TYROLIT Hydrostress unit and have thus acquired a highly sophisticated and reliable state-of-the-art device. Only genuine TYROLIT Hydrostress replacement parts can guarantee quality and interchangeability. If maintenance work is neglected or carried out inexpertly, we will be unable to honour our warranty obligations. All repairs must be carried out by trained personnel only.

Our after-sales service is available to help ensure that your TYROLIT Hydrostress units remain in perfect working order.

We hope that working with your TYROLIT unit will be a satisfying and fault-free experience.

TYROLIT Hydrostress

Copyright © TYROLIT Hydrostress

TYROLIT Hydrostress AG  
Witzbergstrasse 18  
CH-8330 Pfäffikon  
Switzerland  
Tel. 0041 (0) 44 952 18 18  
Fax 0041 (0) 44 952 18 00

## Table of contents

	Page
<b>1. 1. Safety</b> .....	5
1.1 What to do in an emergency .....	6
<b>2. Description</b> .....	7
2.1 System .....	7
2.2 Main components .....	8
2.3 Remote controller .....	10
2.4 Connections .....	11
<b>3. Operation</b> .....	14
3.1 Overview of controls .....	14
3.2 Display elements .....	15
3.3 Positioning the WSE1621P control unit .....	25
3.4 Starting the WSE1621P control unit .....	26
3.5 Selecting the machine system .....	28
3.6 Selecting the mains power supply .....	28
3.7 Tool soft start .....	29
3.8 Selecting the tool station .....	30
3.9 Power control .....	31
3.10 Adjusting the feed .....	31
3.11 Changing the direction of rotation of the main motor .....	33
3.12 Daily hour counter / stopwatch .....	34
3.13 Switching off the WSE1621P control unit .....	35
3.15 Deactivating the EMERGENCY STOP function .....	36
<b>4. Servicing and maintenance</b> .....	37
4.1 High-pressure cleaning .....	37
4.2 Cleaning the water filter .....	38
4.3 Blowing out water .....	38
4.4 Rechargeable batteries .....	39
4.5 Recycling waste .....	39

<b>5. Malfunctions</b> .....	40
<b>6. Technical data</b> .....	41
6.1 Dimensions .....	41
6.2 Weights .....	41
6.3 Electrical data .....	42
6.4 Water .....	42
6.5 Recommended ambient temperature .....	42
6.6 Remote controller .....	42
<b>7. EC Declaration of Conformity</b> .....	43
<b>8. Spare parts</b> .....	44

To order go to [Discount-Equipment.com](http://Discount-Equipment.com)

# 1 Safety



## DANGER

Failure to comply with the safety instructions in the "Safety Manuals / System Manuals" may result in serious injury or even death.

- ▶ Make sure the "Safety Manuals / System Descriptions" for the relevant type of saw have been read and understood in full.



## DANGER

### Death or serious injury can be caused by sudden start-up of the machine!

- ▶ Before switching on the system, ensure that no other persons are present in the danger areas.
- ▶ Switch the system off before connecting or disconnecting cables.
- ▶ When leaving the system unattended: switch off and secure the system to prevent it being switched on again.

### Death or serious injury as a result of the sawing machine continuing to run after an accident

- ▶ Ensure that the EMERGENCY STOP button can be reached quickly.

### Electric shock from live cables and connectors!

- ▶ Switch off the WSE1621 Control unit before connecting or disconnecting cables.
- ▶ Ensure the power supply is earthed and fitted with an AC/DC sensitive residual current circuit breaker (FI type B) with a maximum residual current of 30mA.

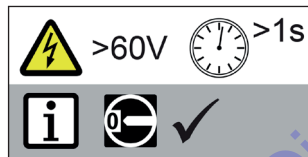

### Risk of fire due to incorrect mains voltage!

- ▶ Make sure the mains voltage and mains frequency correspond with the mains settings of the WSE1621 Control unit.

## 1.1 What to do in an emergency

- ▶ Press the EMERGENCY STOP button on the remote controller.

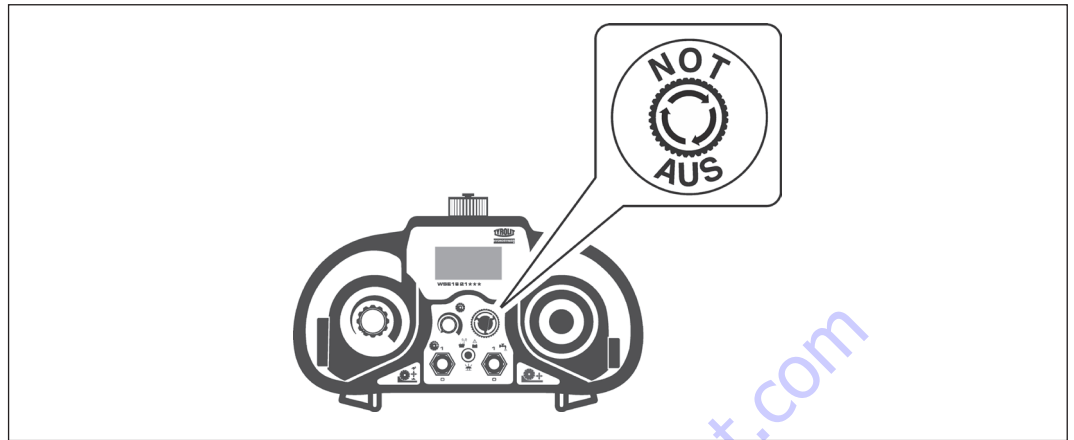

EMERGENCY STOP

If the EMERGENCY STOP function is activated on the radio remote controller, the power supply of the main motor is interrupted.



In the event of an emergency, the machine systems can also be switched off via the main switch on the WSE1617 control unit.

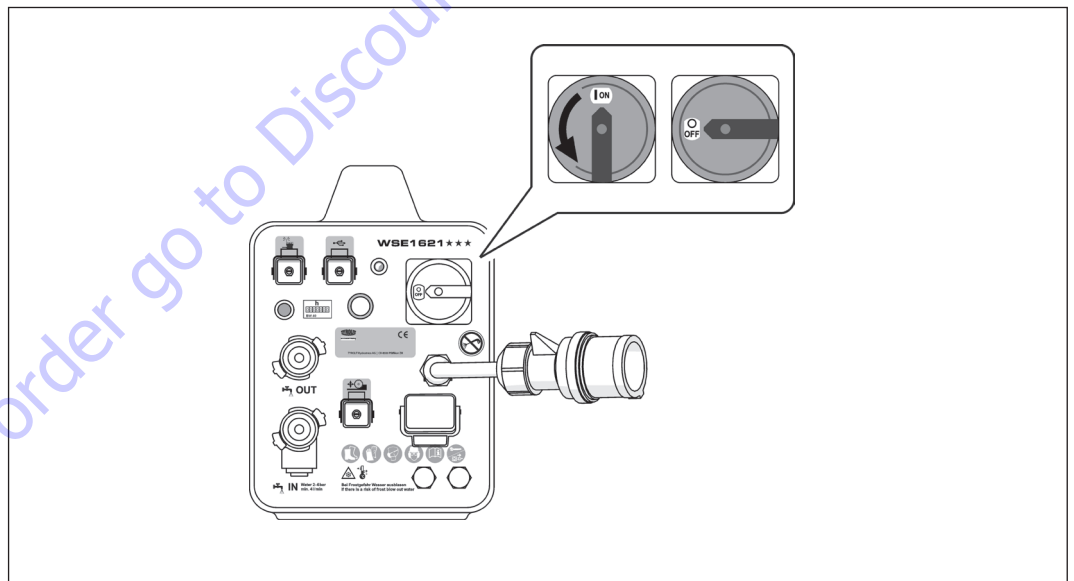

Main switch

## 2 Description

### 2.1 System



The WSE1621 Control unit / Remote controller can be used to operate various TYROLIT machine systems.

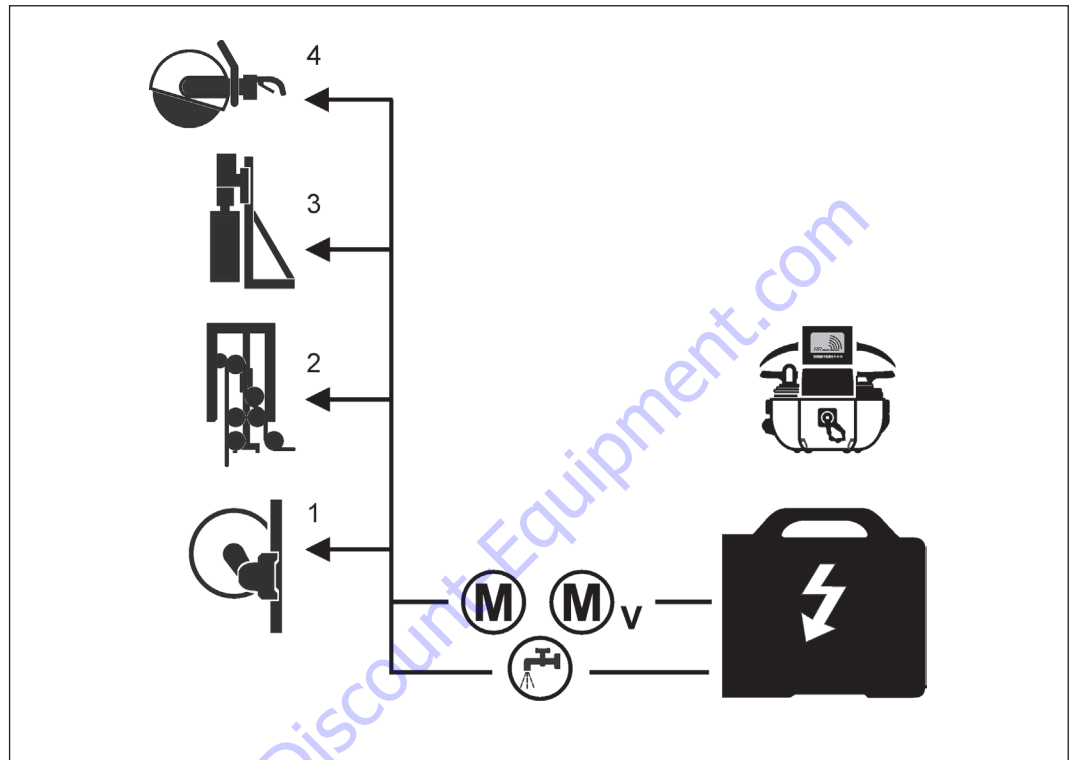

System

- 1 Wall saw systems
- 2 Wire saw systems
- 3 Core drilling systems
- 4 Hand saw systems

M Connection for main/drive motor

Mv Connection for feed motor(s)

 Water connection



## 2.2 Main components

### 2.2.1 Main components Control unit

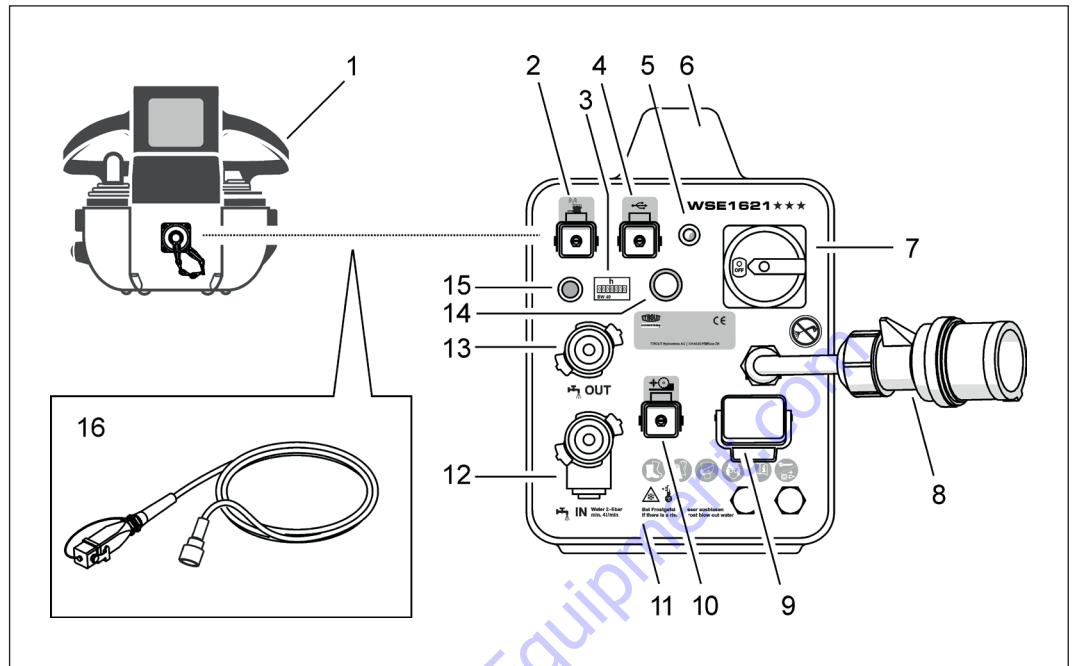

Main components Control unit

- |                                    |                                      |
|------------------------------------|--------------------------------------|
| 1 Remote controller                | 9 Connection for main motor          |
| 2 Connection for remote controller | 10 Connection for feed motor         |
| 3 Hour counter                     | 11 Switchboard                       |
| 4 USB port                         | 12 Water coupling / water inlet      |
| 5 Indicator light                  | 13 Water coupling / water outlet     |
| 6 Housing with grip                | 14 Radio antenna / remote query      |
| 7 Main switch                      | 15 Radio antenna / remote controller |
| 8 Power supply                     | 16 Remote controller cable           |

## 2.2.2 Main components Remote controller

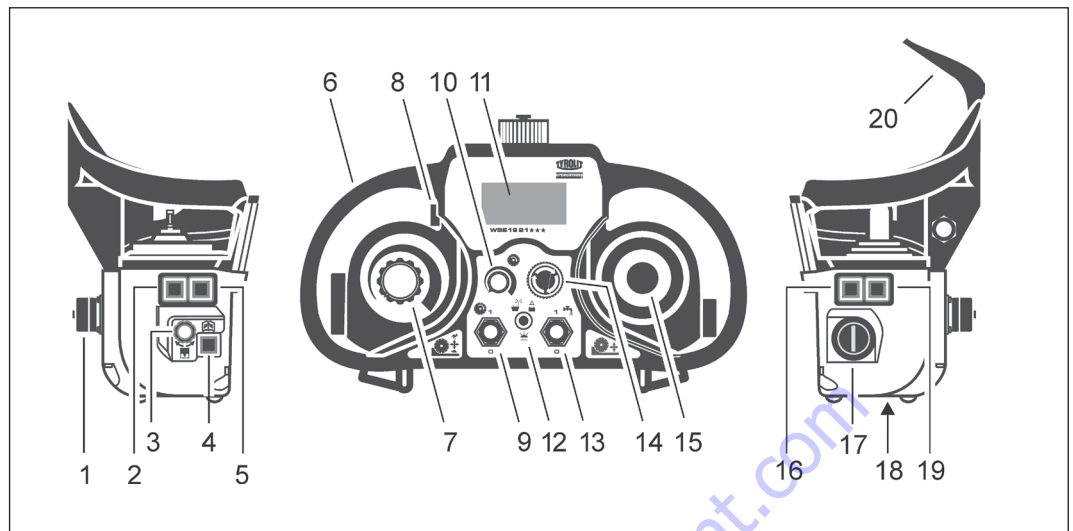

### Main components of remote controller

- |  |                                      |
|--|--------------------------------------|
| 1 Connection for remote controller cable | 11 Display                           |
| 2 Locking button (traverse feed)         | 12 Indicator light (radio & battery) |
| 3 Rotary knob/push button, universal     | 13 Water On/Off                      |
| 4 Menu selection button                  | 14 EMERGENCY STOP                    |
| 5 Tool selection button                  | 15 Feed joystick                     |
| 6 Casing                                 | 16 Pulse button                      |
| 7 Feed motor potentiometer               | 17 Start switch                      |
| 8 USB port                               | 18 Battery compartment               |
| 9 Main motor On/Off                      | 19 Reset button                      |
| 10 Main motor potentiometer              | 20 Sun shield                        |

## 2.2.3 Accessories for remote controller



The battery charger is exclusively designed for recharging the original interchangeable rechargeable batteries. The battery holder and the cable insert must not be inserted.

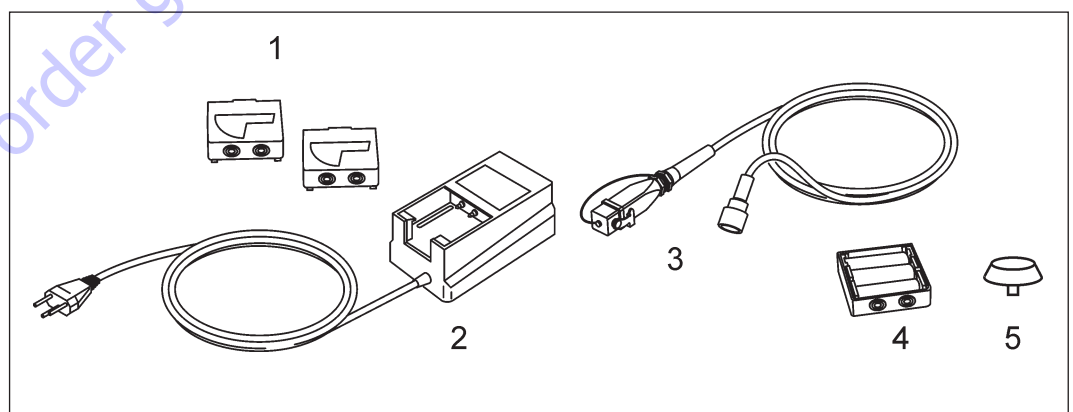

### Accessories

- |  |              |
|--|--------------|
| 1 2x interchangeable rechargeable batteries            | No. 10999383 |
| 2 Rechargeable battery charger                         | No. 10984305 |
| Rechargeable battery charger with 10–30 VDC connection | No.10984840  |
| 3 Remote controller cable                              | No. 10999372 |
| 4 Battery holder                                       | No. 10999384 |
| 5 Key  | No. 10984309 |

## 2.3 Remote controller



The remote controller can be replaced by an accumulator or a battery operated radio remote controller. The remote controller can also be operated using a cable.

### 2.3.1 Operating modes

#### Radio remote controller

The transmitter and receiver are a pair of matched units. They cannot be used with other devices. The number on the back of the remote controller must match the serial number on the machine name plate.

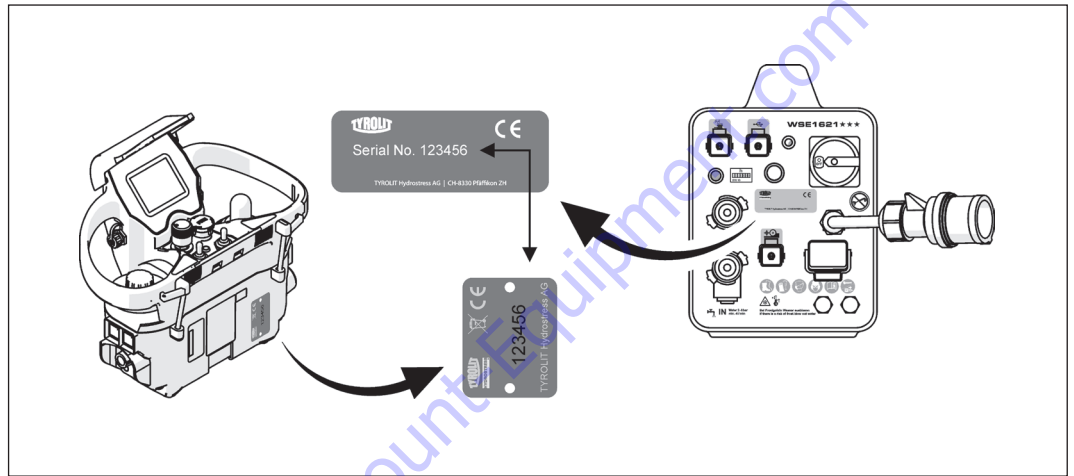

Radio remote controller

### 2.3.2 Operating modes

#### Rechargeable battery operation:

The interchangeable rechargeable battery is inserted in the base of the casing of the remote controller. The operating period with a fully charged battery is approximately 12 hours. The maximum reception distance is 25 m.

#### Ordinary battery operation:

The battery insert included in the scope of supply allows operation with three 1.5 V AA batteries. The reception distance is 25 m and the maximum operating time is 1 hour.

#### Cable operation:

The cable insert is included in the scope of supply and allows connection of the remote controller to the WSE1621 Control unit. The cable length is 10 m. Cable operation makes it possible to work in areas where radio operation is not allowed (e.g. hospitals).

When working with the cable connection, all control signals are transmitted via the electric cable. The rechargeable/ordinary battery holders must not be inserted in the base of the casing during cable operation.

## 2.4 Connections

### 2.4.1 Establishing connections for the control unit

- ✓ The control unit is isolated from the power supply
- ✓ The connectors and couplings are clean
- ✓ Cables and hoses are undamaged

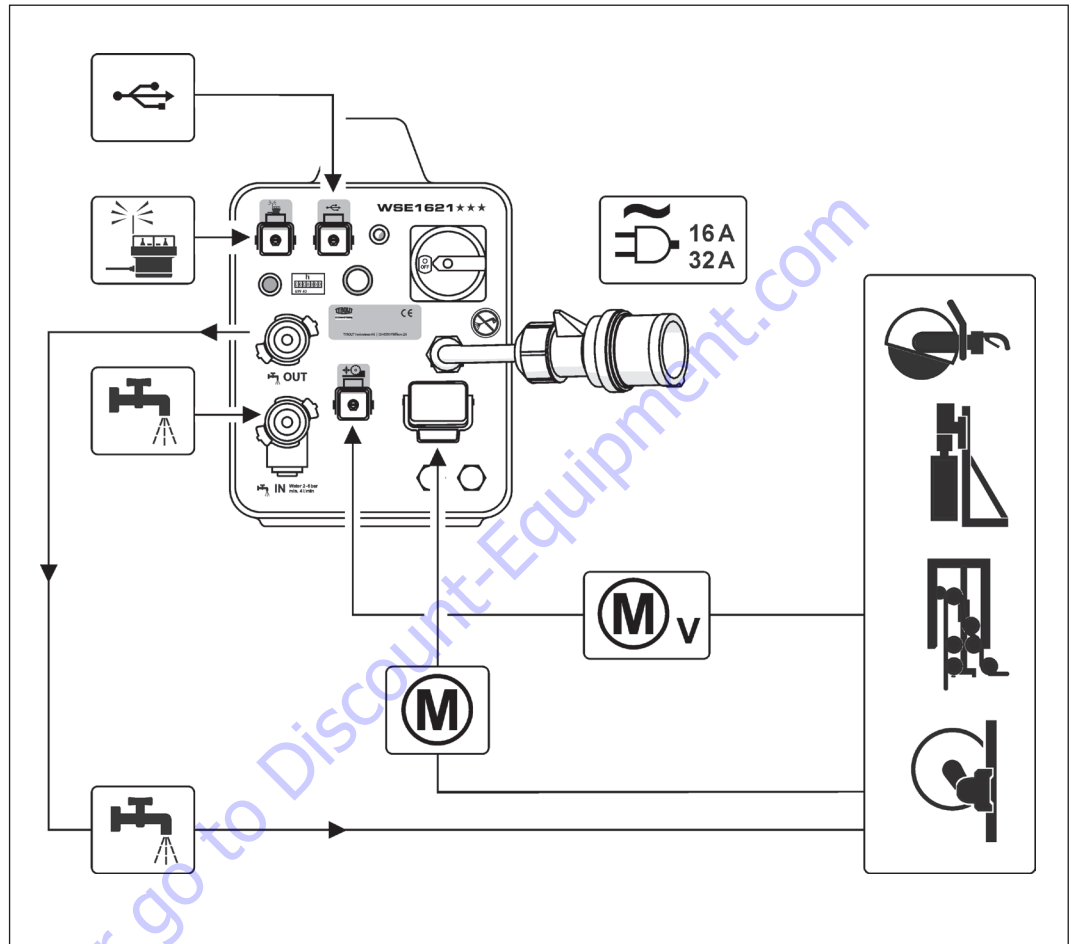

Control unit connections

- Cutting tool drive motor
- Feed motor
- Water
- Mains supply
- Cable connection for remote controller
- USB port

## 2.4.2 Connecting the power and water supply

### Connecting motors

- ✓ The power supply is earthed and fitted with a residual current operated protective device (FI; max. residual current 30mA)
- ✓ Sufficient cable cross-sections: up to 25 m long 5 x 4 mm<sup>2</sup>, more than 25 m long 5 x 6 mm<sup>2</sup>
- ✓ Connectors are clean
- ✓ Cables are undamaged

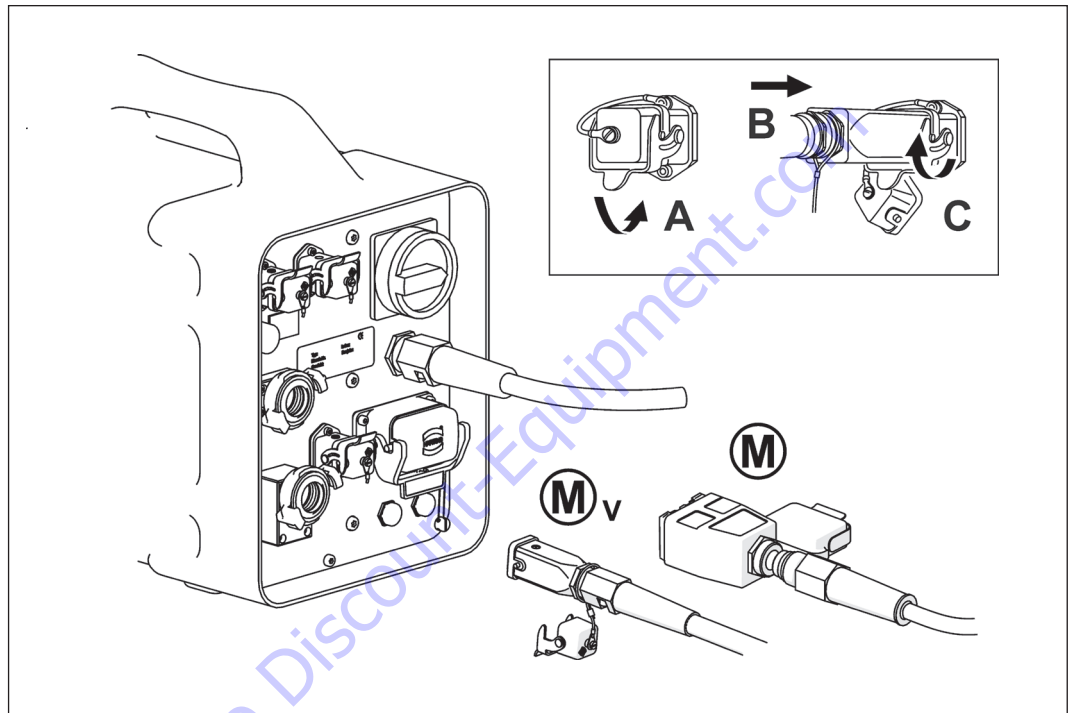

Connecting motors

- M Cutting tool drive motor
- M v Feed motor

### Connecting the water supply

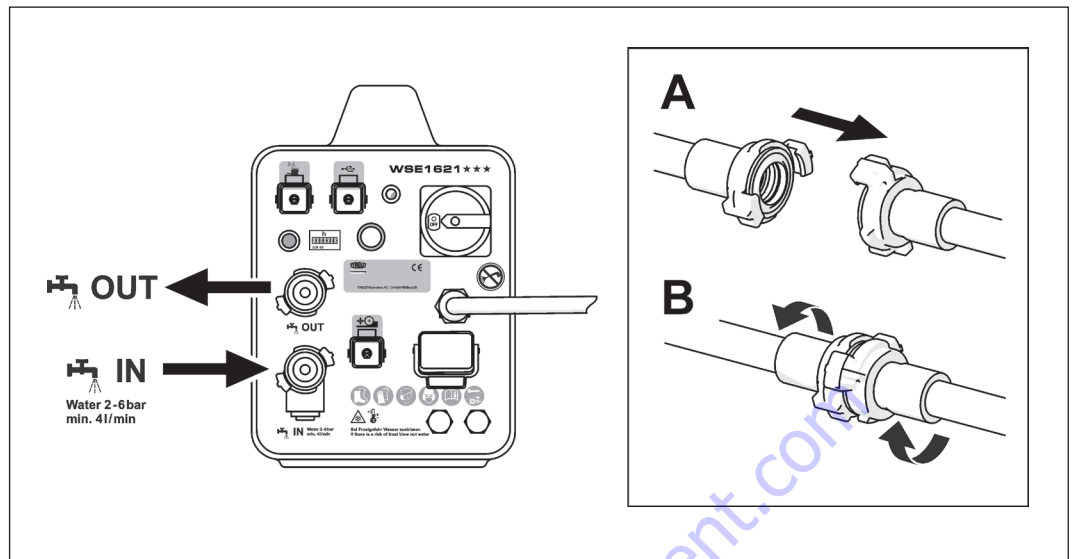

Water connections



The WSE1621 Control unit is cooled by water. The control unit must also be cooled during dry applications. The incoming water is routed through the water filter via the control unit and on to the machine system. After cooling the main motor of the machine system during a dry application, the water is drained via a water hose.

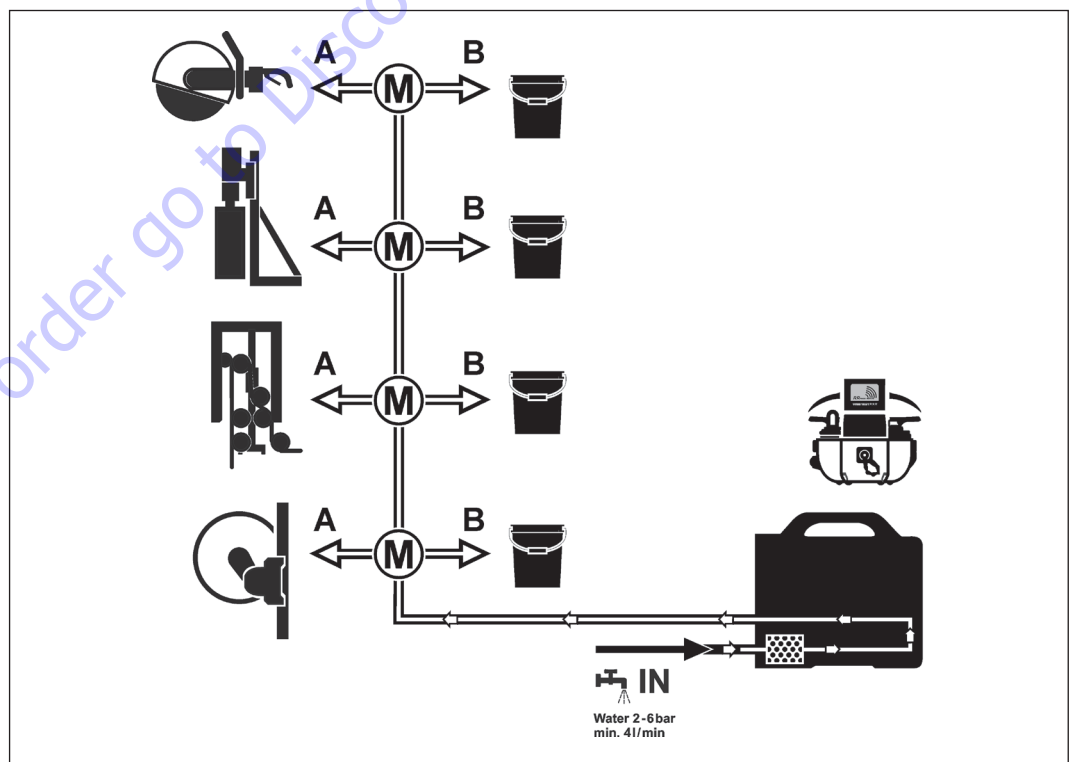

Control unit connections

- A Wet applications
- B Dry applications

### 3 Operation

#### 3.1 Overview of controls

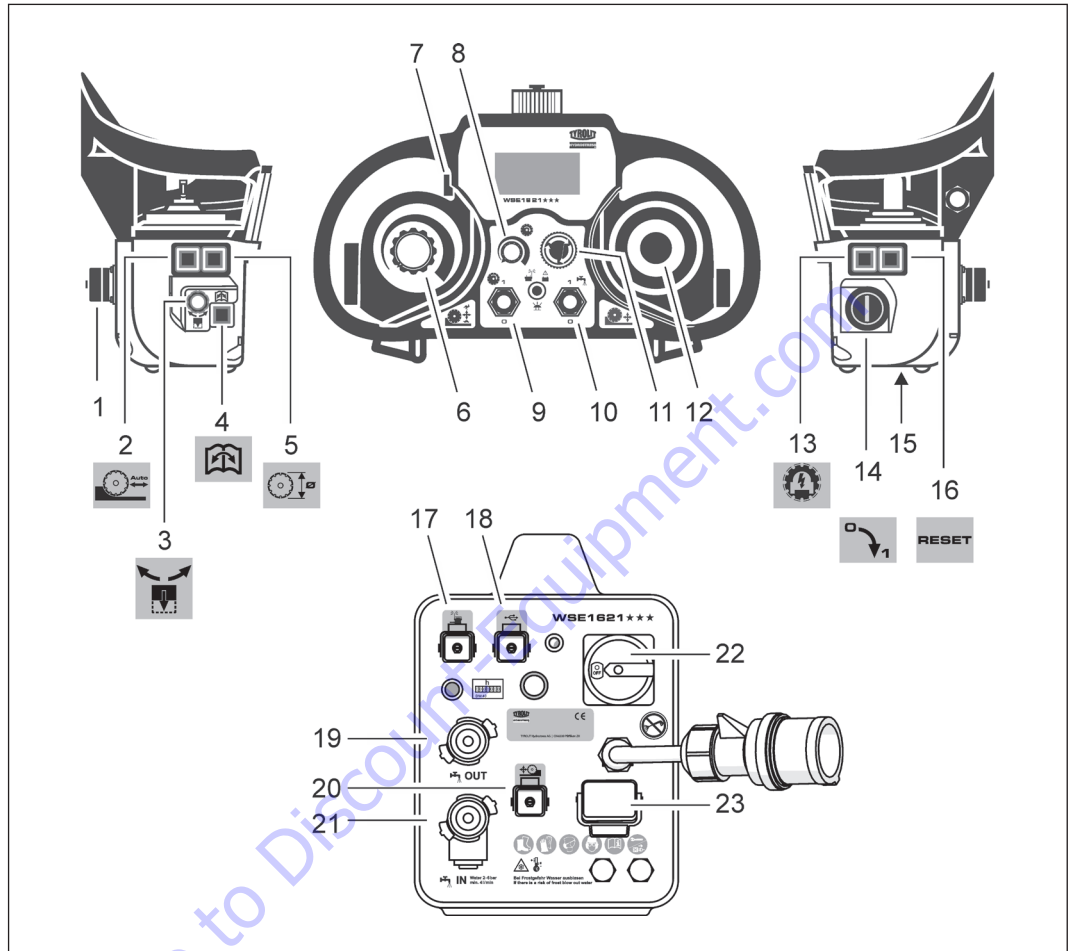

Controls

- |  |   |
|--|---|
| 1 Connection for remote controller cable | 13 Pulse button                           |
| 2 Locking button (traverse feed)         | 14 Start switch                           |
| 3 Rotary knob/push button, universal     | 15 Battery compartment                    |
| 4 Menu selection button                  | 16 Reset button                           |
| 5 Tool selection button                  | 17 Connection for remote controller cable |
| 6 Feed motor potentiometer               | 18 USB port                               |
| 7 USB port                               | 19 Water connection                       |
| 8 Main motor potentiometer               | 20 Connection for feed cable              |
| 9 Main motor On/Off                      | 21 Water connection                       |
| 10 Water On/Off                          | 22 Start switch                           |
| 11 EMERGENCY STOP                        | 23 Connection for main motor cable        |
| 12 Feed joystick                         |   |

### 3.2 Display elements

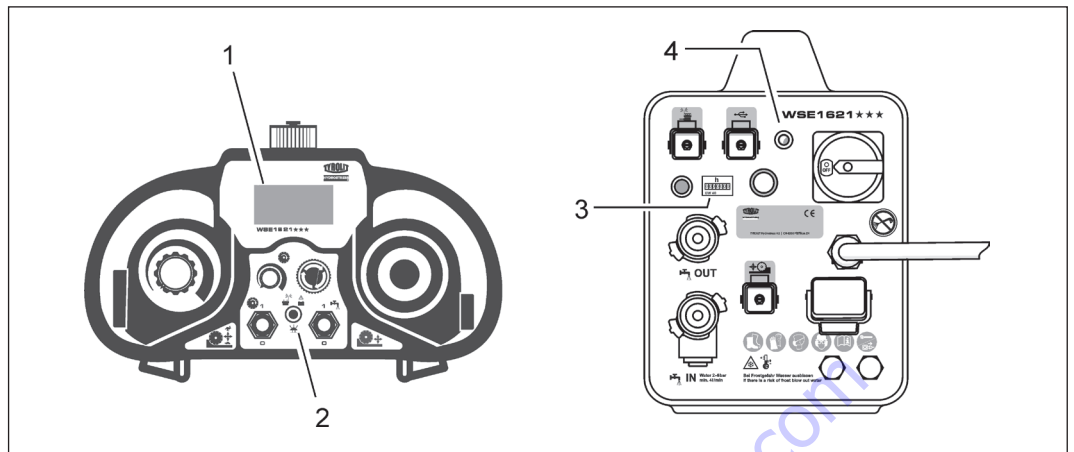

Display elements

- 1 Display
- 2 Indicator light (radio & battery)
- 3 Hour counter
- 4 Indicator light (ON/OFF)

#### 3.2.1 Display fields

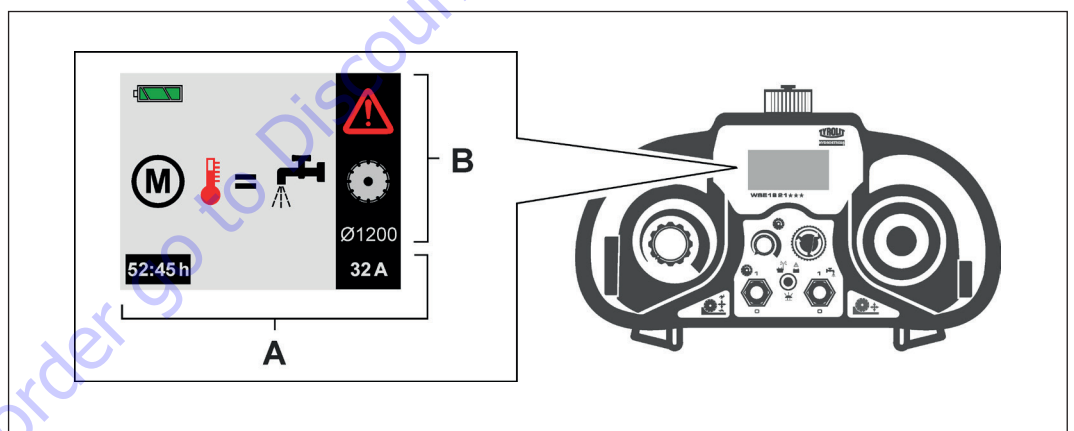

Display fields

- A Vario information field
- B Status information field

#### Vario information field



The vario information field displays information regarding faults, power and time.

#### Status information field









The status information field displays information regarding the machine system.

























### 3.2.2 Display symbols













#### Status information field

	Error displays		Ø TYROLIT diamond tool
	System displays		Ø high-speed diamond tool
	Repair / service displays		Ø drill bit
			Diamond wire

#### Vario information field

	Operating Instructions		Phase
	Electric		Phase missing
	Information		Relay
	Main motor		FC intermediate circuit
	Repair / service		FC output stage
	Potentiometer		Data exchange
	Potentiometer 0 position		EMERGENCY STOP function / ON
	Water		EMERGENCY STOP function / OFF
	Rechargeable battery: Battery empty		Contact
	Rechargeable battery: Low battery level		Stopwatch / daily hour counter
	Rechargeable battery: Fully charged		Electronics

**Vario information field**

	Insert feed		Current
	Advance feed		Overcurrent
	Feed		Undercurrent
	Main motor, clockwise direction of rotation		Earth
	Main motor, counter-clockwise direction of rotation		Earth fault
	Overheating		Equal sign



The individual vario symbols can be combined to create statements

Example of an error display:

Cause: Overtemperature of main motor

Action: Cool with water

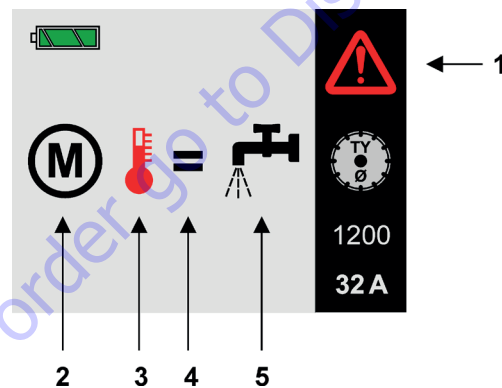

Example of vario fields

Display:

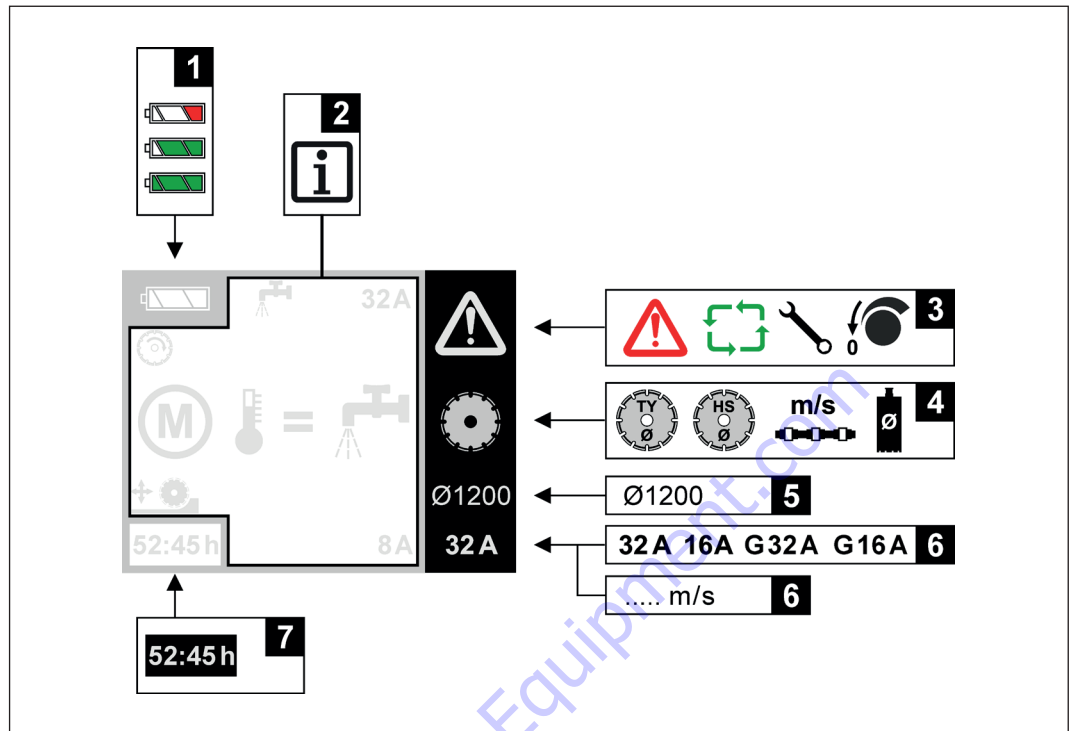

Error display (1): Main motor (2) has reached overtemperature (3), countermeasure equals (4) cool with water (5).

### 3.2.3 Display segments



Display fields





#### 1 Power supply

-  1/3 red Rechargeable battery: Battery empty
-  2/3 green Rechargeable battery: Low battery level
-  3/3 green Rechargeable battery: Fully charged

#### 2 Information field

-  The vario information field displays information regarding faults, power and operating status.

#### 3 Display status

-  This status indicates an error in the Information field.
-  This status indicates operating/system information in the Information field.
-  This status indicates repair information in the Information field.
-  Potentiometer of the feed motor is not in the 0 position.

#### 4 Machine system display



Wall saws with TYROLIT diamond tool



Wall saws with TYROLIT high-speed diamond tool



Wire saws Diamond tool speed



Core drilling Ø diamond tool

#### 5 Type / dimension of cutting tool

Ø 1200 e.g. saw blade with Ø 1200mm (650mm / 825mm / 1025mm / 1200mm / 1600mm)

#### 6 Mains power supply display / speed of diamond tool



The mains power supply is displayed in field 6, which, during the cutting procedure, switches to the speed of the diamond tools.



16 A mains power supply / G16 A generator



32 A mains power supply / G32 A generator

... m/s Speed of the diamond tool

#### 7 Time field

... h 00:00h time field



The machine system is detected automatically during the startup process.



The WSE1621 Control unit is preset for a 32 A mains power supply. (32A appears on the display). It is possible to switch to a 16 A mains power supply. The control unit will automatically return to the 32 A setting when it is restarted.



The WSE1621 Control unit will switch off if it is not used for 30 seconds. The control unit can be reactivated by pressing the pulse button (12).

### 3.2.4 Power display during operation



The current power range is displayed with a coloured bar and a power value (digit adjusts continuously).  
 Ideal scenario: In the second orange segments (in iron in the third red segments).

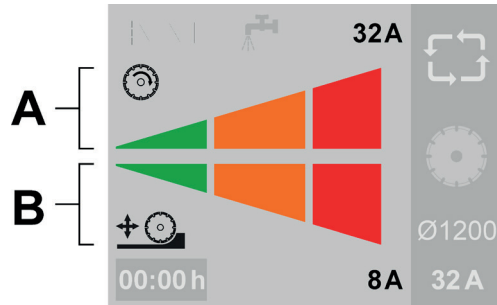

Display of the power for the feed- and main motor

- A Power display for the main motor
- B Power display for the feed motor

#### Display of the power for the feed- and main motor

**Power display during operation**

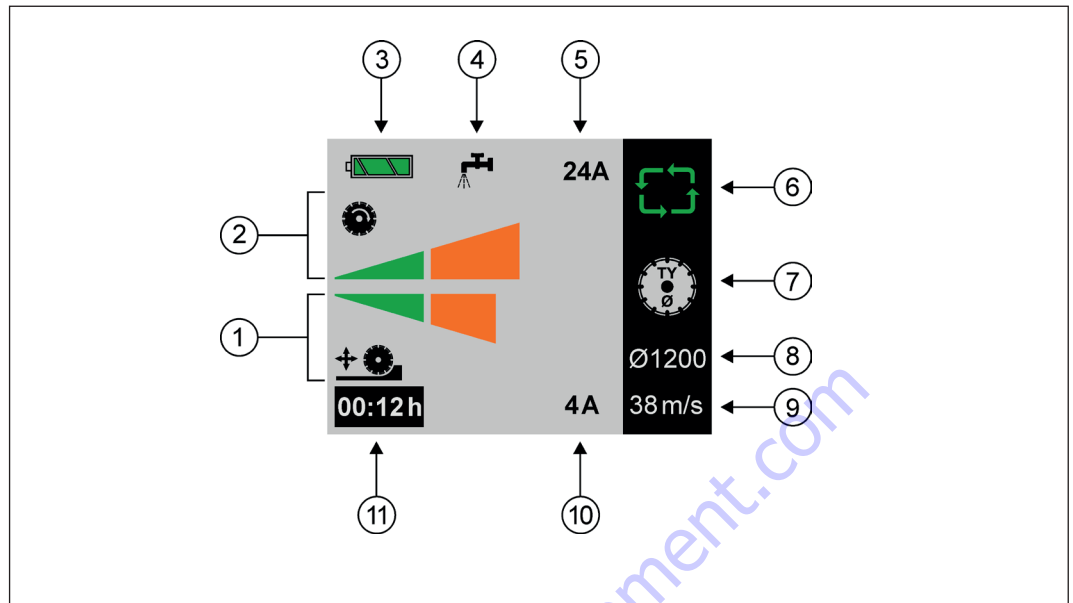

	<p>Operation with less than 40% nominal power</p>	<p>Example:</p>
	<p>Operation with 40% to 80% nominal power</p>	
	<p>Motors are operated at 100%</p>	<p>Main motor 80% nominal power                  Feed motor 80% nominal power</p>

### 3.2.5 Examples of an operating screen







Display fields

#### Status information









































- 6  The machine system is in the operating mode
- 7  Wall saw with TYROLIT saw blade
- 8 Ø1200 Saw blade diameter Ø1200mm

#### Vario information











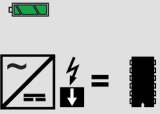

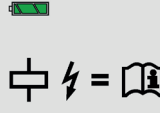

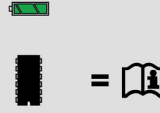
- 1  The feed motor operates at a nominal power between 40 and 100%
- 2  The main motor operates at a nominal power of 75%
- 3  Rechargeable battery: Fully charged
- 4  The diamond tool is supplied with water
- 5 24A Current nominal power of the main motor: 24A (adjusts continuously)
- 9 38m/s The speed of the diamond tool is 38m/s
- 10 4A Current nominal power of the feed motor: 4A (adjusts continuously)
- 11 00:12 h The machine system has been in use for 12 minutes

### 3.2.6 Error displays

Error displays			
Error		Possible cause	Action
	Mains phase missing	<ul style="list-style-type: none"> <li>Fault during installation</li> <li>Fuse defective</li> </ul>	<ul style="list-style-type: none"> <li>Check phases and fuses</li> </ul>
	Overtemperature of frequency converter	<ul style="list-style-type: none"> <li>Absence of cooling</li> <li>Ambient temperature too high</li> <li>No, too little or too hot cooling water</li> </ul>	<ul style="list-style-type: none"> <li>Avoid direct contact with sunlight</li> </ul>
	Overtemperature of feed motors	<ul style="list-style-type: none"> <li>Absence of cooling</li> <li>Ambient temperature too high</li> </ul>	<ul style="list-style-type: none"> <li>Allow control unit to cool down for 3 minutes</li> <li>Avoid direct contact with sunlight</li> </ul>
	Overtemperature of control unit components	<ul style="list-style-type: none"> <li>Absence of cooling</li> <li>Ambient temperature too high</li> </ul>	<ul style="list-style-type: none"> <li>Allow control unit to cool down for 3 minutes</li> <li>Avoid direct contact with sunlight</li> </ul>
	Overtemperature of the main motor	<ul style="list-style-type: none"> <li>Absence of cooling</li> <li>No, too little or too hot cooling water</li> </ul>	<ul style="list-style-type: none"> <li>See Technical data</li> </ul>
	Short circuit fault	<ul style="list-style-type: none"> <li>Blocked main motor</li> </ul>	<ul style="list-style-type: none"> <li>Contact TYROLIT after-sales service</li> </ul>
	Short circuit detection of the main motor	<ul style="list-style-type: none"> <li>Earth fault</li> </ul>	<ul style="list-style-type: none"> <li>Contact TYROLIT after-sales service</li> </ul>
	Main motor overcurrent	<ul style="list-style-type: none"> <li>Main motor blocked</li> <li>Overcurrent earth fault</li> </ul>	<ul style="list-style-type: none"> <li>Contact TYROLIT after-sales service</li> </ul>

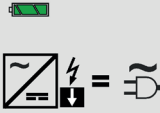
Error displays			
	Error	Possible cause	Action
  ⚡ =  52:45 h	  Ø1200 32 A	Main motor current earth fault	<ul style="list-style-type: none"> <li>Electrical connection earth fault</li> <li>Contact TYROLIT after-sales service</li> </ul>
  ⚡ =  52:45 h	  Ø1200 32 A	Overcurrent DC axis	<ul style="list-style-type: none"> <li>Feed motor overloaded</li> <li>Reduce feed</li> </ul>
  ⚡ =  52:45 h	  Ø1200 32 A	DC motor short circuit	<ul style="list-style-type: none"> <li>Blocked feed motor</li> <li>Defective feed motor</li> <li>Contact TYROLIT after-sales service</li> </ul>
  =  52:45 h	  Ø1200 32 A	The safety relay no longer switches properly	<ul style="list-style-type: none"> <li>Hardware defect</li> <li>Contact TYROLIT after-sales service</li> </ul>
  =  52:45 h	  Ø1200 32 A	The safety contact no longer functions properly.	<ul style="list-style-type: none"> <li>Hardware defect</li> <li>Contact TYROLIT after-sales service</li> </ul>
  =  52:45 h	  Ø1200 32 A	Transformer fault	<ul style="list-style-type: none"> <li>Motor outside of possible parameters</li> <li>Contact TYROLIT after-sales service</li> </ul>
  ⚡ =  52:45 h	  Ø1200 32 A	Overvoltage at the feed output stage	<ul style="list-style-type: none"> <li>Defective power supply unit</li> <li>Power supply unit overloaded</li> <li>Contact TYROLIT after-sales service</li> </ul>
  =  52:45 h Fehler	  Ø1200 32 A	EMERGENCY STOP has been actuated	<ul style="list-style-type: none"> <li>EMERGENCY STOP has been actuated</li> <li>Radio communication has been interrupted</li> <li>Reset the EMERGENCY STOP push-button, perform the startup procedure</li> <li>Change the radio frequency by switching the key switch on the radio remote controller on and off</li> </ul>

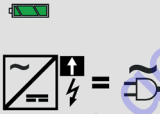

Error displays			
Error		Possible cause	Action
   Ø1200 32 A	Overvoltage at the feed output stage	<ul style="list-style-type: none"> <li>Defective power supply unit</li> <li>Power supply unit overloaded</li> </ul>	<ul style="list-style-type: none"> <li>Contact TYROLIT after-sales service</li> <li>Switch to generator mode</li> </ul>
   Ø1200 32 A	Main contactor does not switch	<ul style="list-style-type: none"> <li>Defective main contactor</li> </ul>	<ul style="list-style-type: none"> <li>Contact TYROLIT after-sales service</li> </ul>
   Ø1200 32 A	Fan does not rotate	<ul style="list-style-type: none"> <li>Defective fan</li> </ul>	<ul style="list-style-type: none"> <li>Contact TYROLIT after-sales service</li> </ul>
   Ø1200 32 A	Communication fault	<ul style="list-style-type: none"> <li>Communication fault due to interference</li> </ul>	<ul style="list-style-type: none"> <li>Contact TYROLIT after-sales service</li> </ul>
   Ø1200 32 A	Direct current link voltage too low	<ul style="list-style-type: none"> <li>Incorrect mains voltage</li> </ul>	<ul style="list-style-type: none"> <li>Check the mains voltage; see Technical data</li> </ul>
   Ø1200 32 A	Direct current link voltage too high	<ul style="list-style-type: none"> <li>Mains overvoltage</li> <li>The saw blade feeds back too much energy.</li> </ul>	<ul style="list-style-type: none"> <li>Check the mains voltage; see Technical data</li> <li>Only use diamond saw blades between Ø650mm (25.5") and Ø1600mm (63")</li> <li>Switch to generator mode</li> </ul>

### 3.3 Positioning the WSE1621 Control unit



**CAUTION**

The WSE1621 Control unit can be damaged if it slips or topples over!

- ▶ Make sure the WSE1621 Control unit is level and located on a firm surface (grip at the top).



The WSE1621 Control unit should only be switched on when level and upright.

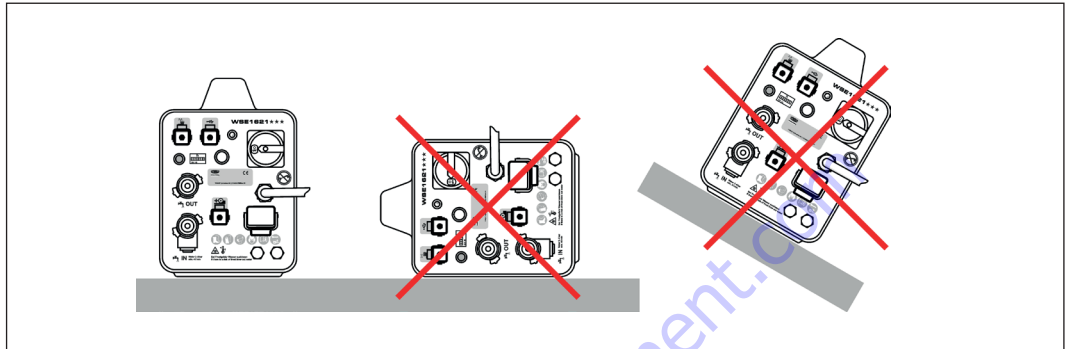

Positioning the WSE1621 Control unit



**CAUTION**

Risk of water damage to the WSE1621 Control unit.

- ▶ Make sure the WSE1621 Control unit is not positioned in water and that it is located at a safe distance to any splash water.

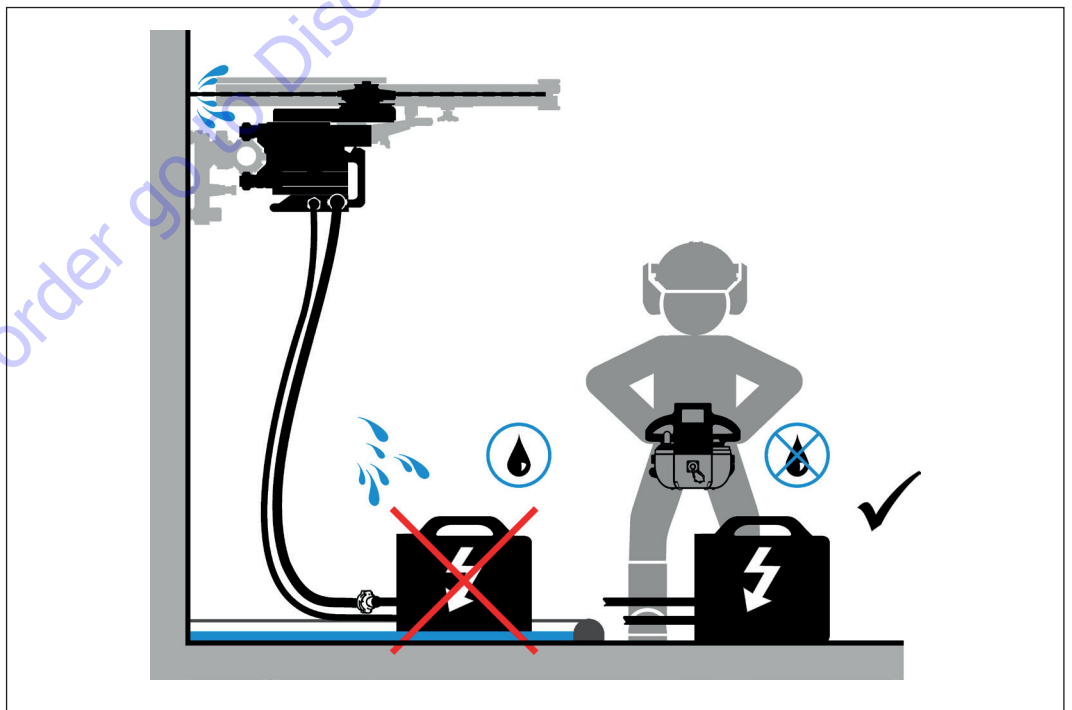

Positioning the WSE1621 Control unit

### 3.4 Starting the WSE1621 Control unit

- ✓ The WSE1621 Control unit is connected to the mains and the water supply.
- ✓ The machine system is connected to the WSE1621 Control unit.  
(See "Operating instructions - Sawing system")
- ✓ The remote controller EMERGENCY STOP (11) has been deactivated.

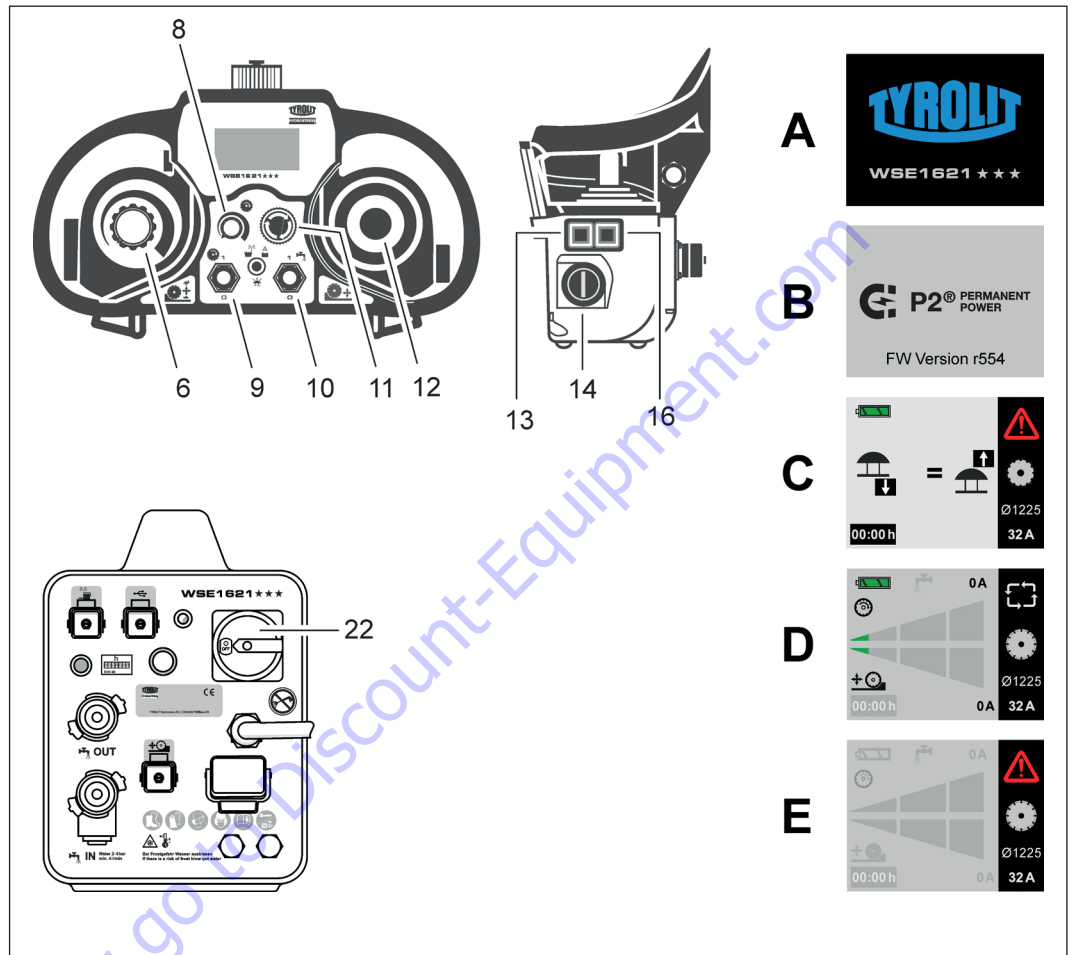

Starting the control unit

- ▶ Move the operating elements listed below on the remote controller to their 0 position.

- Feed motor potentiometer (6)
- Main motor potentiometer (8)
- Main motor On/Off (9)
- Water switch (10)
- Feed joystick, automatically takes up 0 position (12)
- Start switch (14)

- ▶ Switch on the WSE1621 Control unit by using the main switch (22).
- ▶ Switch on the radio remote controller using the start switch (14).

- Indicator lights (radio and battery) initially light up red
- An audible signal is emitted simultaneously
- The TYROLIT logo (A) appears in the display
- The P2 logo and firmware version e.g. r554 appear in the display (B)
- "EMERGENCY STOP information" screen appears in the display (C)
- The indicator light flashes green



If only the remote controller is switched on, the P2 screen will remain on the display.  
Application: Check display of software version e.g. r554

- ▶ Press the blue reset button (16) on the radio remote controller.
  - The operating screen (D) appears on the display
  - If an error message (E) appears, press the blue reset button (16) again.
- ▶ Press the green pulse switch (13)
  - The system indicator on the display lights up.
  - The feed and main motors are released from this point onwards.
  - The control unit automatically detects which machine system is connected.
- ▶ Open the water valve on the system supply line.
  - The water valve is displayed on the screen
- ▶ Press the Water On/Off switch (10) on the remote controller to I.
  - Water emerges at the cutting tool.
- ▶ Press the main motor On/Off switch (9) on the remote controller to position I.
  - The electric motor starts when the main motor potentiometer is in the max. position.
- ▶ The WSE1621 Control unit has started up and is ready for operation.

### 3.4.1 Changing the frequency of the remote controller

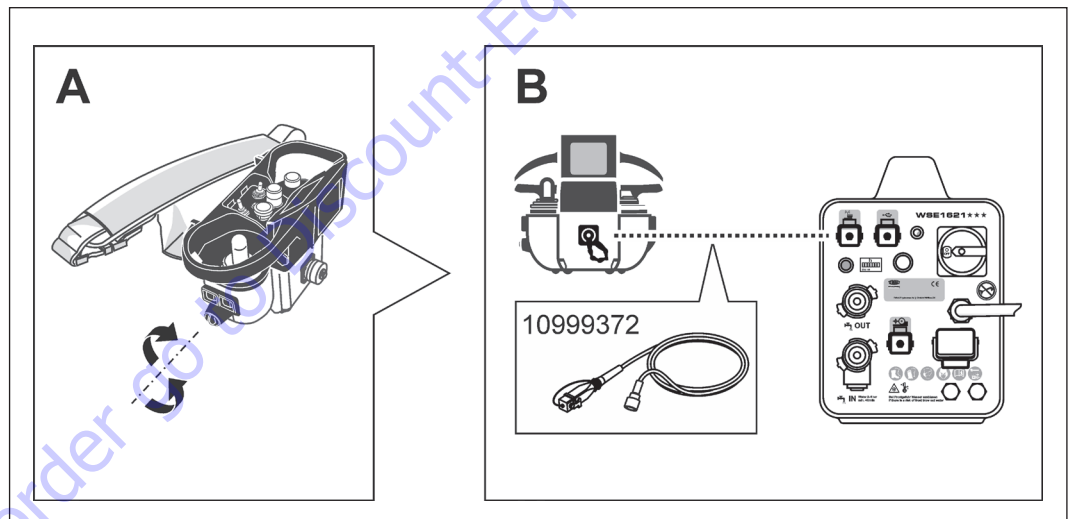

Frequency search



The radio remote controller systems are equipped with a frequency generator for selecting a frequency.

If the systems experience a malfunction or radio communication is interrupted (external transmitter, range, rechargeable battery empty), the systems immediately revert to the EMERGENCY STOP state.

#### New frequency search:

The next frequency is selected by switching the start switch on the remote controller off and then on again.

The process of switching off and on is limited to four attempts (channels). If the system does not locate a suitable frequency after four attempts, a changeover to cable operation is necessary.

### 3.5 Selecting the machine system



The machine system is detected automatically during the startup process.

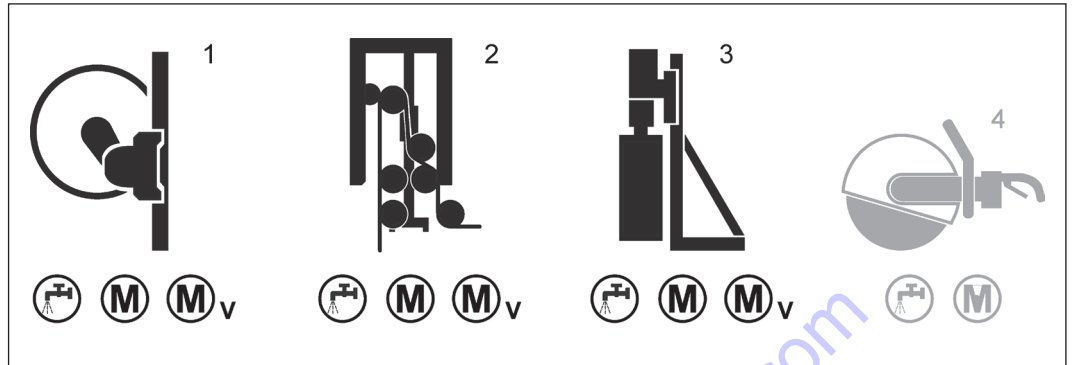

Detecting the machine system

- |   |                      |     |                          |
|---|----------------------|-----|--------------------------|
| 1 | Wall sawing system   | M   | Cutting tool drive motor |
| 2 | Wire sawing system   | M v | Feed motor               |
| 3 | Core drilling system | M   | M v                      |
| 4 | Hand saw             |     | Water                    |

### 3.6 Selecting the mains power supply



The WSE1621 Control unit is preset for a 32 A mains power supply. (32A appears on the display). The mains power supply can be switched to a 16 A setting or an emergency power supply mode (G32A / G16A). The control unit will automatically return to the 32 A setting when it is restarted.

To switch the control unit to the 16 A setting or emergency power supply mode (G32A / G16A), perform the startup procedure as far as the point designated **“Press the black locking button (2) on the radio remote controller”**.

Instead of using the pulse button (13), you can now use the locking button (2) to switch to the 16 A mains power supply or the emergency power supply mode (G32A / G16A). (16A or emergency power supply (G32A / G16A) appears on the display.)

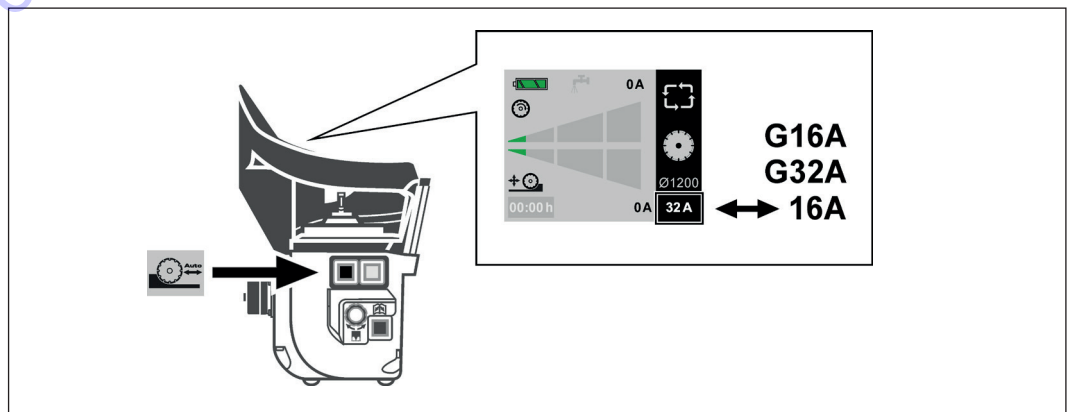

Selecting the mains power supply

### 3.7 Tool soft start



The WSE1621 Control unit offers a tool soft start option. The soft start option is particularly applicable in the case of diamond wire saws.

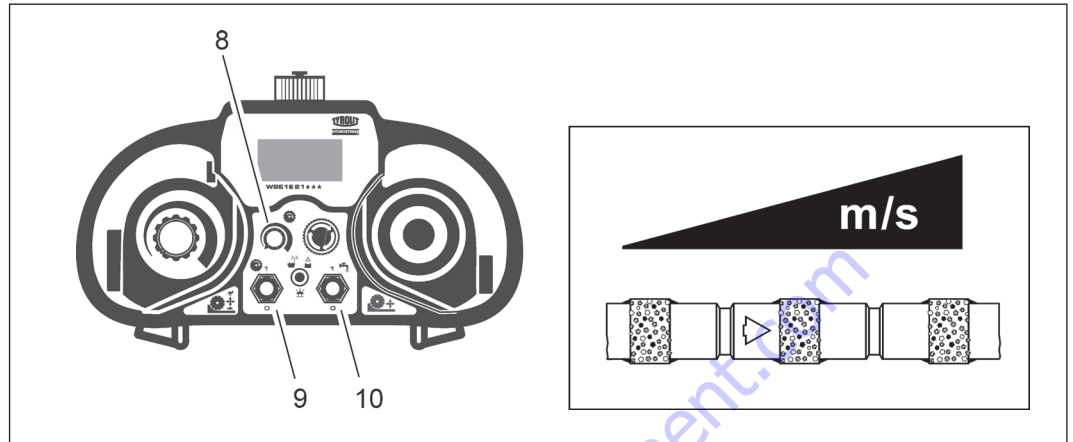

Selecting the tool station

Proceed as follows:

- ▶ Start the WSE1621 Control unit.
- ▶ Turn the main motor potentiometer (8) to the 0 position.
- ▶ Press the Water On/Off switch (10) on the remote controller to I.
- ▶ Press the main motor switch (9) to I.
- ▶ Slowly turn the main motor potentiometer (8) to 100% power.

### 3.8 Selecting the tool station

The machine systems (wall saws, wire saws, core drilling) are detected automatically during the startup process.

When the 1621 control unit has been started correctly, the tool stations can be selected before switching on the main motor.

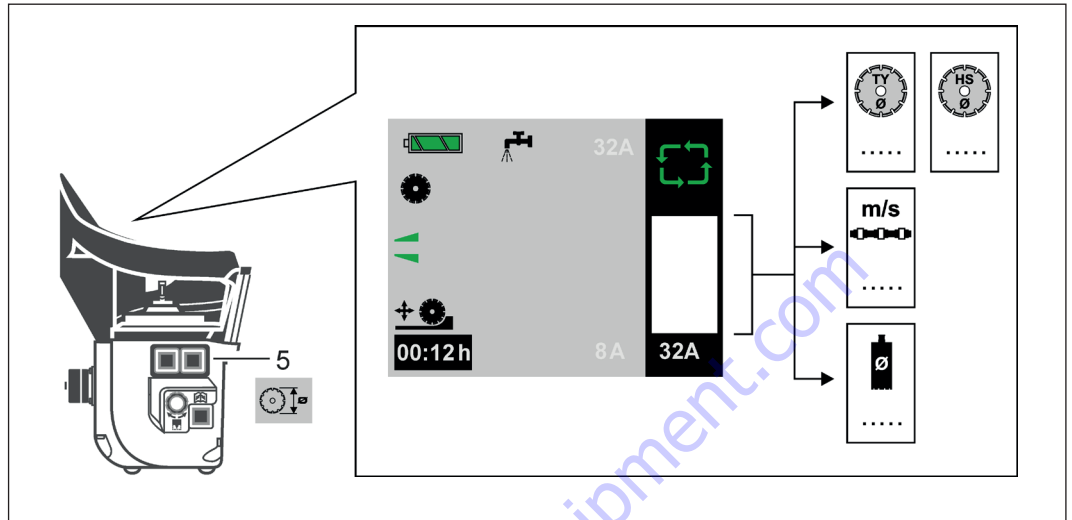

Selecting the tool station



A selection can be made between the following cutting tools:

#### Tool selection



Wall saws

TYROLIT diamond tool  
 (Ø650mm / Ø825mm / Ø1025mm / Ø1200mm / Ø1600mm)



Wall saws

TYROLIT high-speed diamond tool  
 Ø825mm / Ø1025mm / Ø1200mm / Ø1600mm



Wire saws

Diamond tool speed  
 0-26 m/s 0-22 m/s 0-17 m/s



Core drilling

Ø diamond tool  
 Ø150mm / Ø200mm / Ø250mm / Ø300mm / Ø350mm  
 Ø400mm / Ø450mm / Ø500mm / Ø600mm / Ø700mm  
 Ø800mm / Ø900mm / Ø1000mm

Proceed as follows:

- ▶ Press the tool selection button (5). Toggle between the individual dimensions and speed ratings by repeatedly pressing the tool selection button.



To switch to the high-speed diamond tool:

- ▶ To activate the change, press the tool selection button (5) for 3 seconds. When the button is released, the displayed symbol will change.
- ▶ Pressing the tool selection button (5) for 3 seconds again and then releasing it will result in the WSE1621 Control unit reverting back to the standard tools.

### 3.9 Power control

The main motor and the feed motor power are controlled via the potentiometers.

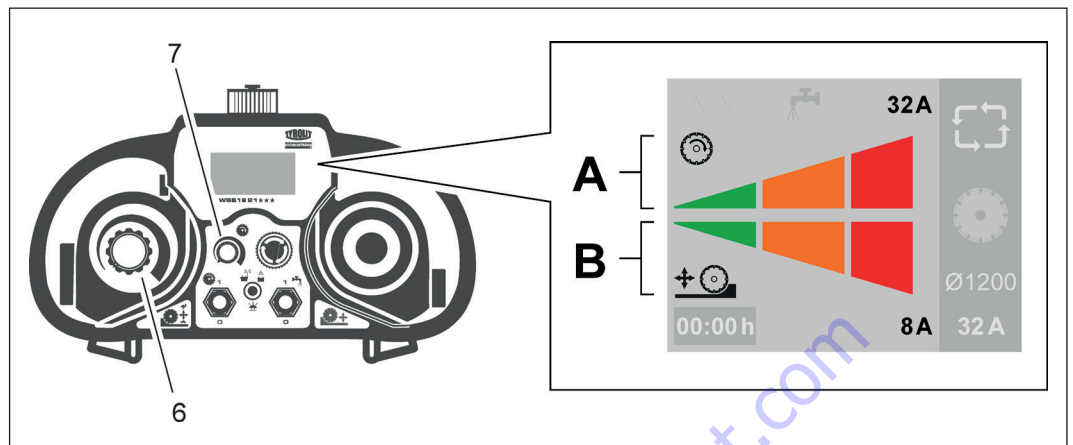

Power control

- A Power display for the main motor (the digit value for current consumption adapts continuously)
- B Power display for the feed motor (the digit value for current consumption adapts continuously)
- 6 Feed motor potentiometer
- 7 Main motor potentiometer

### 3.10 Adjusting the feed

The feed movements are selected with the joystick (12) and the speed is regulated via the potentiometer (6).

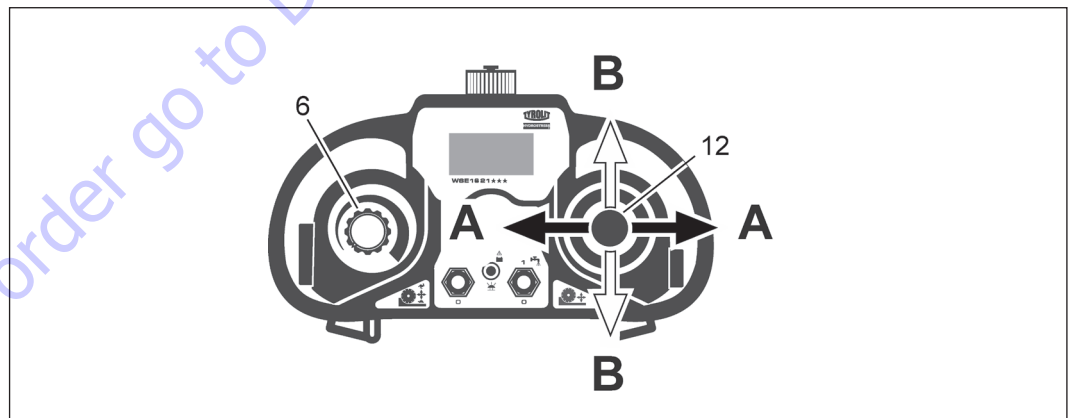

Adjusting the feed



The feed speed is automatically assisted by a feed facility during the cutting process.



### 3.10.1 Manually adjusting the feed speed

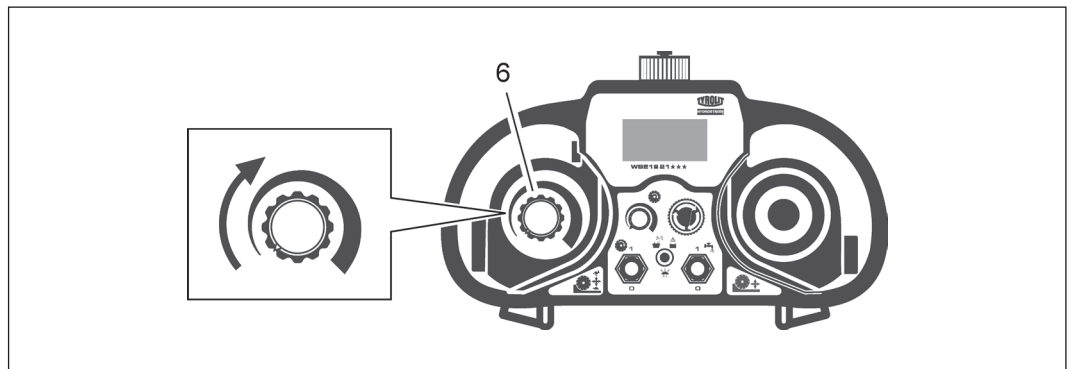

Feed speed

- ✓ The WSE1621 Control unit has been started
- ▶ Select the required feed speed via the feed potentiometer (6).

### 3.10.2 Locking the feed

So that the joystick does not have to be held in position during the travel feed motion, the travel feed can be locked.

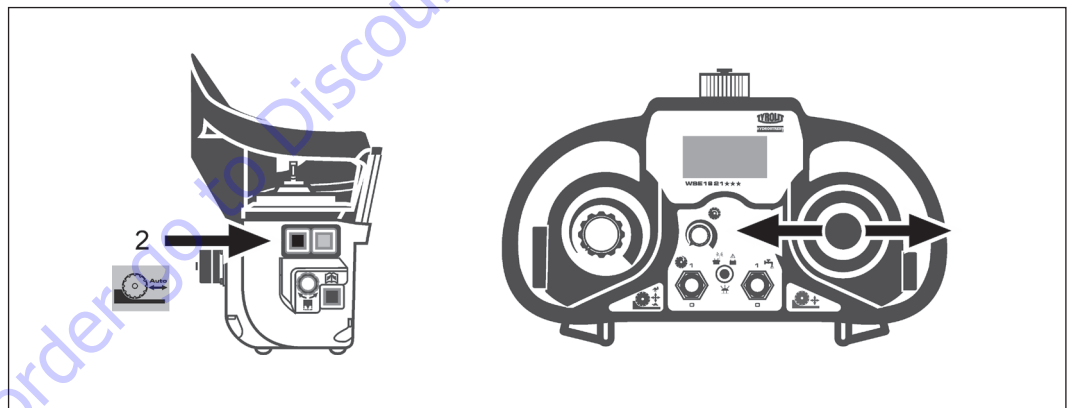

Proceed as follows:

- ▶ Push the joystick in the desired direction of travel and, at the same time, press the locking button (2).
- ▶ When the joystick and the locking button (2) are released, the feed is locked.



In order to release the feed lock, move the joystick slightly in any desired direction or press the locking button.

### 3.11 Changing the direction of rotation of the main motor



This function is only possible for wall sawing applications.  
The direction of rotation can only be changed before starting the main motor.

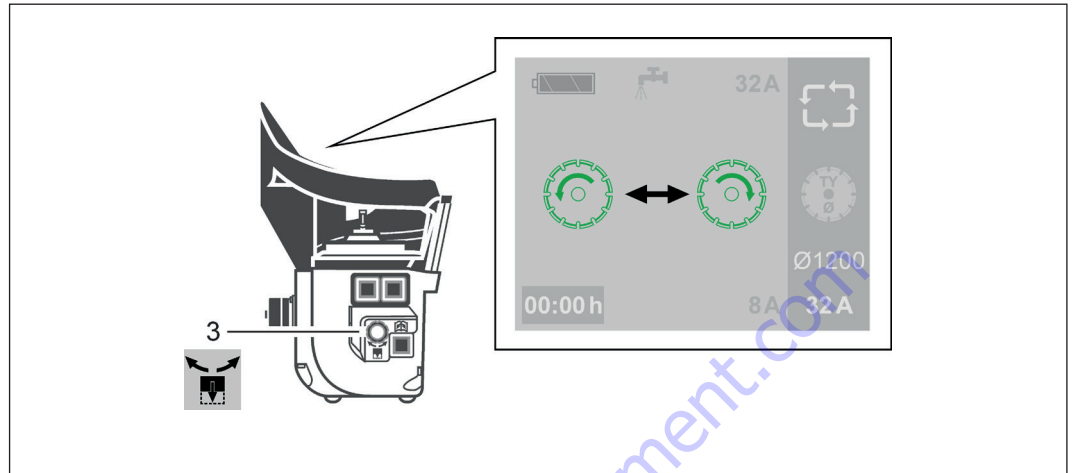

Changing the direction of rotation of the main motor

Proceed as follows:

- ▶ Press the universal rotary knob/push button (3).
  - The current direction of rotation of the main motor is indicated on the display.
- ▶ Turn the universal rotary knob/push button (3) until the direction of rotation changes on the display.
- ▶ Press the universal rotary knob/push button (3).
  - The direction of rotation has been changed and the operating screen is displayed.



When the WSE1621 Control unit is restarted, the direction of rotation of the main motor reverts to the default setting.

### 3.12 Daily hour counter / stopwatch



The WSE1621 Control unit is equipped with a daily hour counter and a stopwatch. The daily hour counter and the stopwatch can be used during operation as and when required.

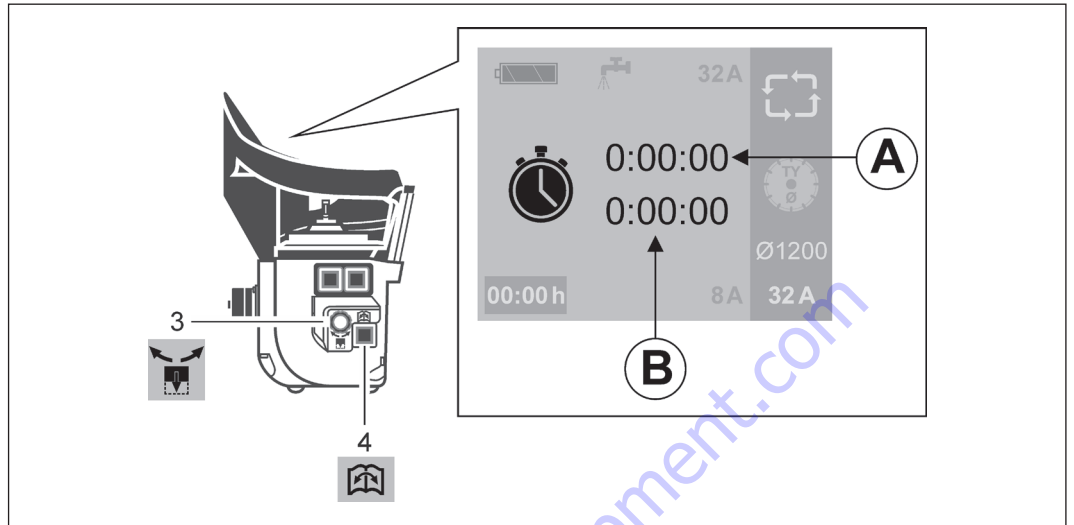

Daily hour counter / stopwatch

- A Stopwatch
- B Daily hour counter

#### 3.12.1 Using the daily hour counter / stopwatch

Proceed as follows:

- ▶ Press the Menu selection button (4).  
– The clock screen appears.
- ▶ You can alternate between the stopwatch and the daily hour counter by turning the universal rotary knob/push button (3).



When the time measurement is active, it is indicated by an asterisk (C).

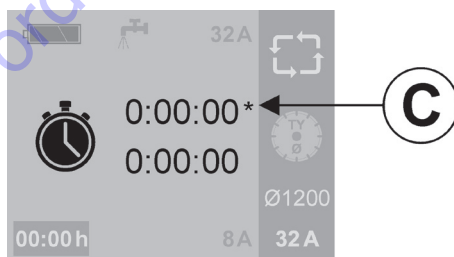

The stopwatch can be started, stopped and reset to 0 by pressing the universal rotary knob/push button (3). The stopwatch is set to 0 when the control unit is switched off.



The daily hour counter is operated in the same way as the stopwatch. The daily hour counter remains active until it is reset manually (by repeatedly pressing the universal rotary knob/push button (3)).

- ▶ To revert back to the operating screen, press the Menu selection button (4).

### 3.13 Switching off the WSE1621 Control unit

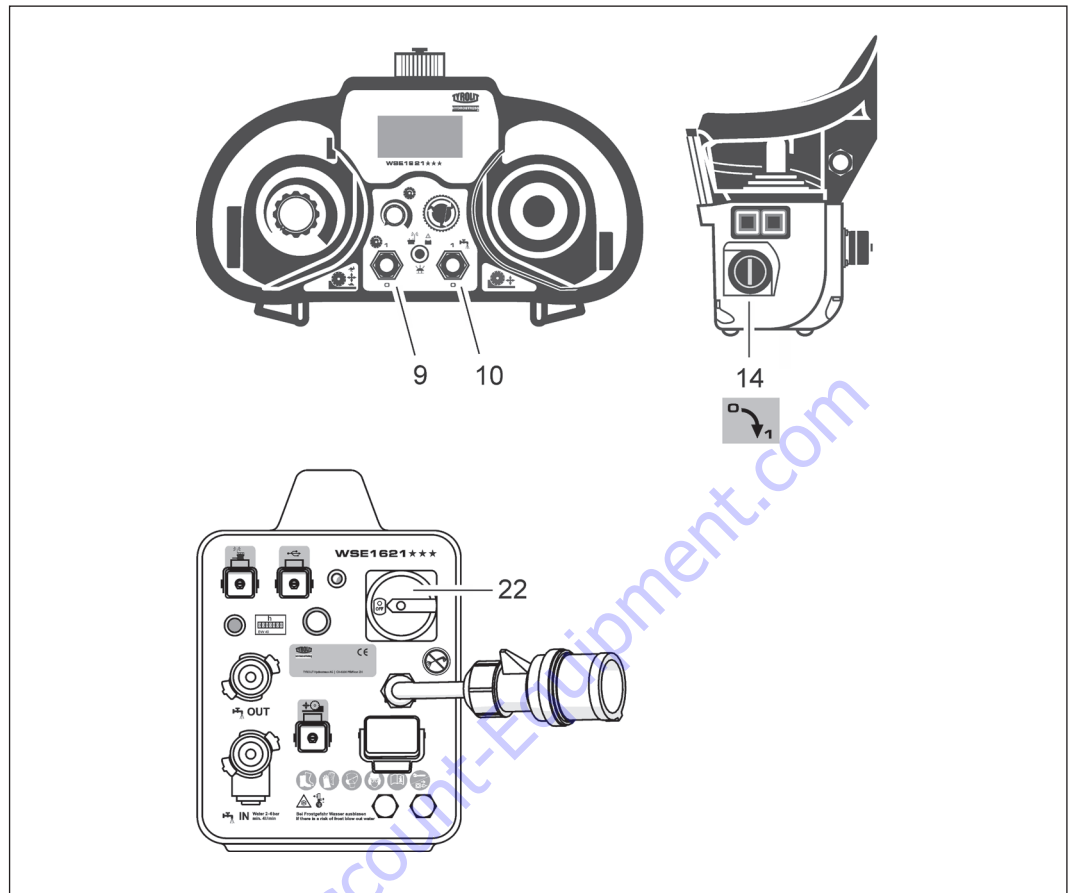

Switching off the control unit

Proceed as follows:

- ▶ Switch off the electric motor, switch (9) Main motor On/Off.
- ▶ Deactivate the cooling water, switch (10) Water On/Off.
- ▶ Close the water valve on the WSE1621 Control unit.
- ▶ Turn the start switch (14) on the remote controller to the 0 position.
- ▶ Switch off the WSE1621 Control unit by using the main switch (22).



#### CAUTION

Risk of frost damage to the WSE1621 Control unit!

- ▶ If there is a risk of frost, blow out any water



Only use the EMERGENCY STOP function in an emergency to stop the WSE1621 Wall saw.

### 3.14 Deactivating the EMERGENCY STOP function

If the EMERGENCY STOP function is activated on the radio remote controller, the radio and battery light (A) will flicker.

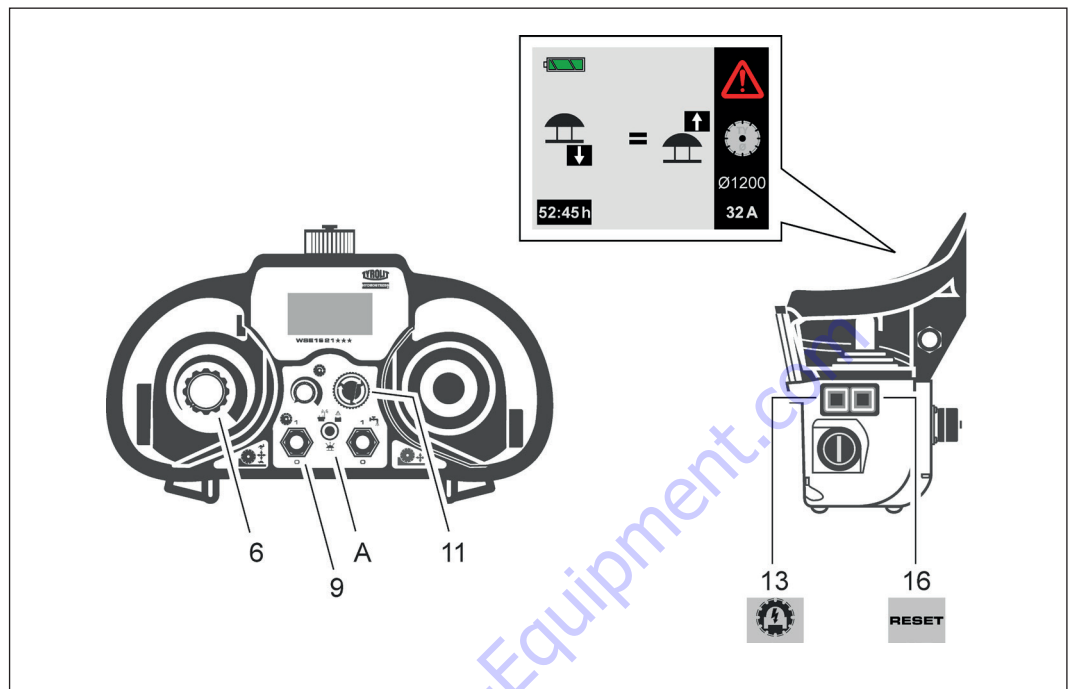

Deactivating the EMERGENCY STOP function

The following controls must be moved to the 0 position:

- Feed potentiometer (6)
- Turn the EMERGENCY STOP button (11) clockwise
  - The EMERGENCY STOP screen appears on the display
- Main motor On/Off (9)..

Proceed as follows:

- ▶ Press the blue reset button (16).
  - The operating screen appears.
- ▶ To continue operation, press the green pulse button (13).

## 4 Servicing and maintenance

Maintenance and servicing table							
		Before each use	After finishing work	Weekly	Annually	After faults	After damage
Electrical system	▶ Check the condition and cleanliness of electric cables, plugs/connectors and switches.	X	X			X	X
	▶ Check the condition and cleanliness of couplings.	X	X			X	X
Water economy	▶ Check water lines for cleanliness and leaks.	X	X			X	X
	▶ Blow out the water if there is a risk of frost.		X			X	X
Overall WSE1621 Control unit	▶ Clean with a damp cloth, do not use a high-pressure cleaner.		X				
Service	▶ To be performed by TYROLIT Hydrostress AG or an authorised workshop.	First service after 100 operating hours Further services after every further 200 operating hours					

### 4.1 High-pressure cleaning



#### Caution

Cleaning using high-pressure cleaning equipment is not permitted. The WSE1621 Wall saw could be damaged if it is cleaned with high-pressure cleaning equipment. Products containing cleaning agent can damage parts of the WSE1621 Wall saw, the remote controller and the cables.



High-pressure cleaner

## 4.2 Cleaning the water filter

✓ Tool

Pliers



Fork wrench



Size 32

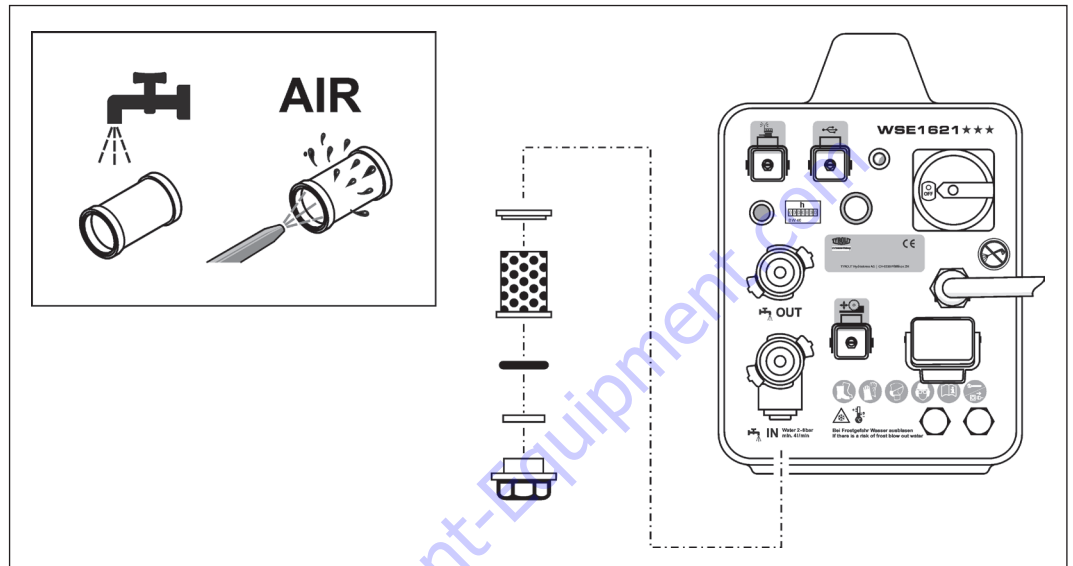

Cleaning the water filter

## 4.3 Blowing out water

✓ The main switch is set to **OFF**

- ▶ Disconnect the mains plug.
- ▶ Disconnect all water lines.
- ▶ Connect a purge pump to the water coupling.
- ▶ Blow out water until all of the cooling water has been removed.
- ▶ Remove the pump.



Blowing out water



To ensure the water can be blown out of the lines properly, use the TYROLIT purge pump, no.10998115.

## 4.4 Rechargeable batteries

### 3.10.2 Handling and use of rechargeable batteries

- ▶ Keep batteries away from high temperatures, direct sunlight and fire.
- ▶ Batteries must not be disassembled, crushed, heated above 80°C or burnt.
- ▶ Damaged batteries must not be charged or reused.
- ▶ If the battery is too hot to touch, it may be defective. Place the product at a sufficient distance to combustible materials in a non-flammable location, where it can be observed, and allow it to cool. Contact TYROLIT customer service when the battery has cooled down.

## 4.5 Recycling waste



TYROLIT Hydrostress power tools are manufactured using a high proportion of recyclable materials. A prerequisite for recycling is proper material separation. In many countries, TYROLIT is already prepared for taking back your used equipment for recycling. Contact TYROLIT customer service or your sales adviser.

To order go to [Discount-Equipment.com](http://Discount-Equipment.com)



## 5 Faults

Faults		
Fault	Possible cause	Solution
The control unit does not work even though the mains cable is connected	Control unit is switched off	▶ Switch on the control unit
	Defective mains cable	▶ Replace the mains cable
	No voltage at the power supply (building site)	▶ Check power supply
	Power supply phases incorrectly connected	▶ Check power supply
	Phase missing	See the chapter entitled "Responding to displays"
The control unit starts and then cuts out again	Power supply fuse at the building site trips	▶ Check the fuse and adjust if necessary ▶ If necessary, change the power supply ▶ See the chapter entitled "Responding to displays"
No power, even though the control unit is running	Incorrect voltage Defective main motor	▶ Make sure the voltage and frequency of the control unit correspond to the specifications for the mains supply ▶ Contact TYROLIT after-sales service
The control unit cuts out suddenly	Over- or undervoltage	▶ Check the power supply. Refer to the error display
	Cross section of power supply cable too small	▶ Check power supply
	Defective plug connection	▶ Check the plug connection ▶ Check power supply
	Group alarm	▶ Refer to the error displays
Main motor is not running	<ul style="list-style-type: none"> <li>• Main motor potentiometer is in 0 position</li> <li>• Defective main motor On/Off switch on remote controller</li> <li>• Water On / Off switch is not in position 1 or it is defective</li> </ul> The remote controller 'Ready' light does not illuminate	▶ Contact TYROLIT after-sales service ▶ Do not start the control unit
	The EMERGENCY STOP is activated	▶ Deactivating the EMERGENCY STOP function
	Overheating	▶ Check the water circuit and the plug-in couplings ▶ Refer to the error displays
	No water	▶ Switch on the water supply ▶ Refer to the error displays
Remote controller not working	Rechargeable battery or batteries have too little charge	▶ Replace and recharge the rechargeable battery or install cable operation ▶ Replace the batteries
Feed potentiometer indicates no function	<ul style="list-style-type: none"> <li>• Defective potentiometer in the remote controller</li> <li>• Feed motors not connected</li> <li>• Defective feed motor</li> <li>• Joystick is in the 0 position</li> </ul>	▶ Contact TYROLIT after-sales service ▶ See the chapter entitled "Responding to displays"
Feed motor fails to build up power	Remote controller potentiometer is defective or in the 0 position	▶ Contact TYROLIT after-sales service
	Defective cable	▶ Contact TYROLIT after-sales service
	Defective motor	▶ Contact TYROLIT after-sales service

## 6 Technical data

### 6.1 Dimensions

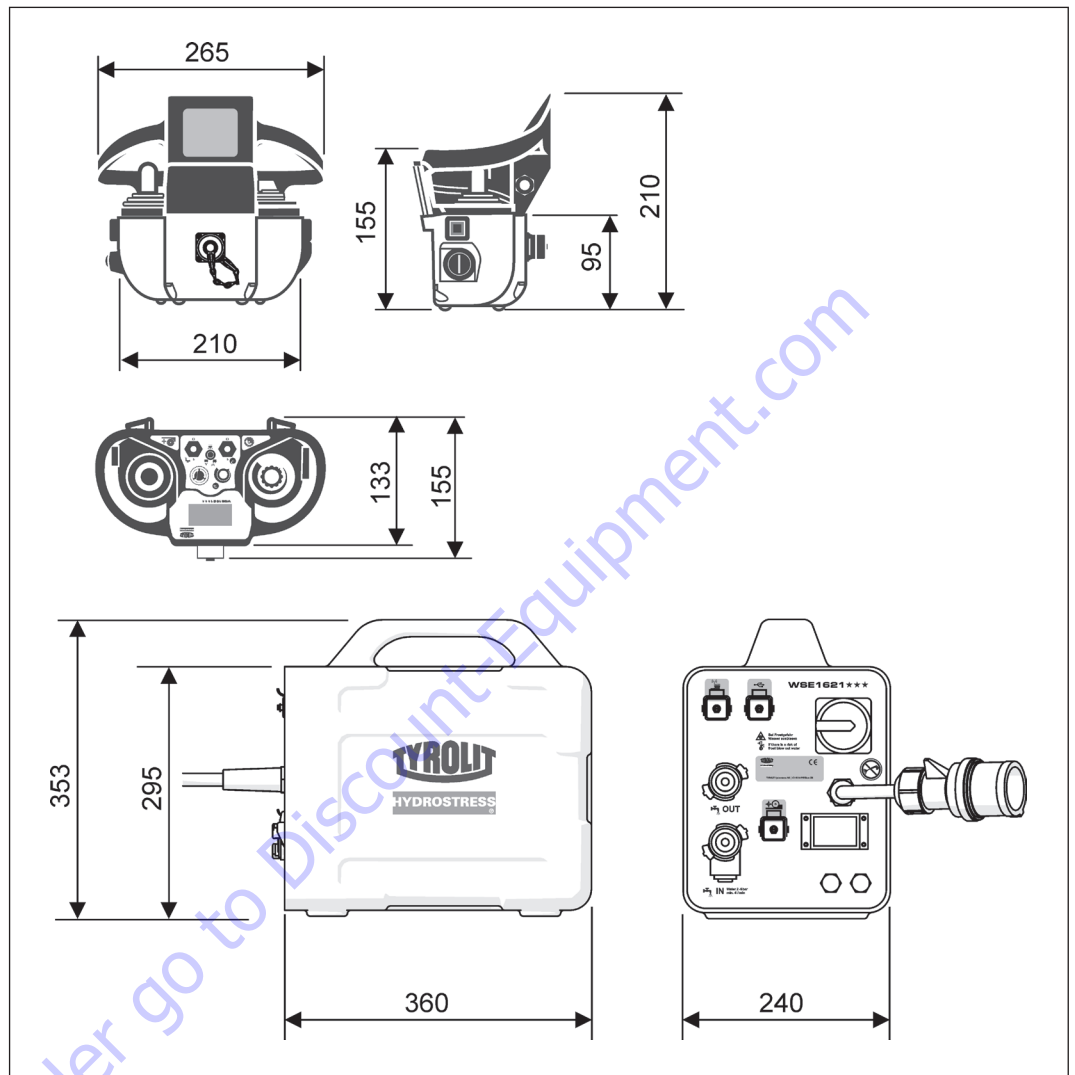

Measurements in mm

### 6.2 Weights

Technical data		
Parameter		Value
Weight	WSE1621 Control unit	11 kg
	WSE1621 Remote controller	1.8 kg

### 6.3 Electrical data

Technical data		
Parameter		Value
Protection class	IP 65	
Connected values	400 to 480 VAC / 50 - 60 Hz	
Power consumption	16 to 32 A (400 V / 50 Hz)	
Output	at 16 A	11 kW
	at 32 A	20 kW
Internal control voltages	Computer/remote controller	24 VDC
	Feed drives	48 VDC
	Main drive unit	400VAC = 565VDC 480VAC = 680 VDC
Converter	High-frequency, water-cooled	

### 6.4 Water

Technical data		
Parameter		Value
Water	Cooling the control unit	Water cooling the power semi-conductors
	Cooling water flow rate	Min. 4 l/min at max 25 °C
	Water connection	2 to 6 bar

### 6.5 Ambient temperature recommendation

Ambient temperature	
Parameter	Value
Storage	-20 °C to 50 °C
Operation	-15°C to 45°C

### 6.6 Remote controller

Remote controller	
Parameter	Value
Cable length (optional)	10 m
Nominal voltage	24 VDC
Protection class	IP 65
Weight	1.8 kg
Frequency	2.4 GHz

## 7 EC Declaration of Conformity

Description	Control unit
Type designation	WSE1621

We declare under our sole responsibility that this product complies with the following directives and standards:

### Directive applied

### Directive applied

2006/42/EC	from 17 May 2006
2011/65/EU	from 08 June 2011
2012/19/EU	from 04 July 2012
2014/30/EU	from 26 February 2014
2014/53/EU	from 16 April 2014

### Applied standards

EN ISO 12100:2010  
 EN ISO 13849-1:2008  
 EN 60204-1:2006+A1:2009  
 EN 61000-6-2:2005  
 EN 61000-6-4:2007+A1:2011

**TYROLIT Hydrostress AG**  
 Witzbergstrasse 18  
 CH-8330 Pfäffikon  
 Switzerland

Pfäffikon, 10/04/2018



Pascal Schmid  
 Head of Development



## 8 Spare parts

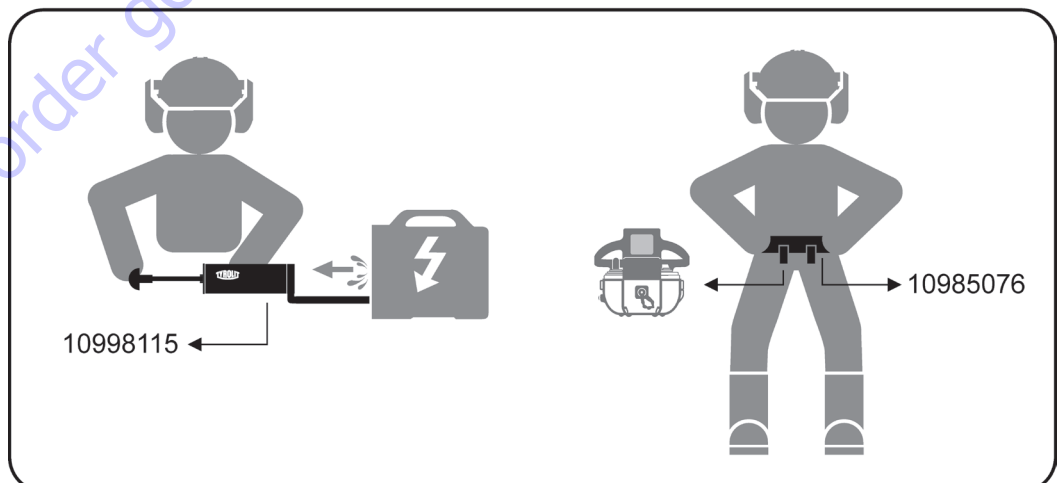
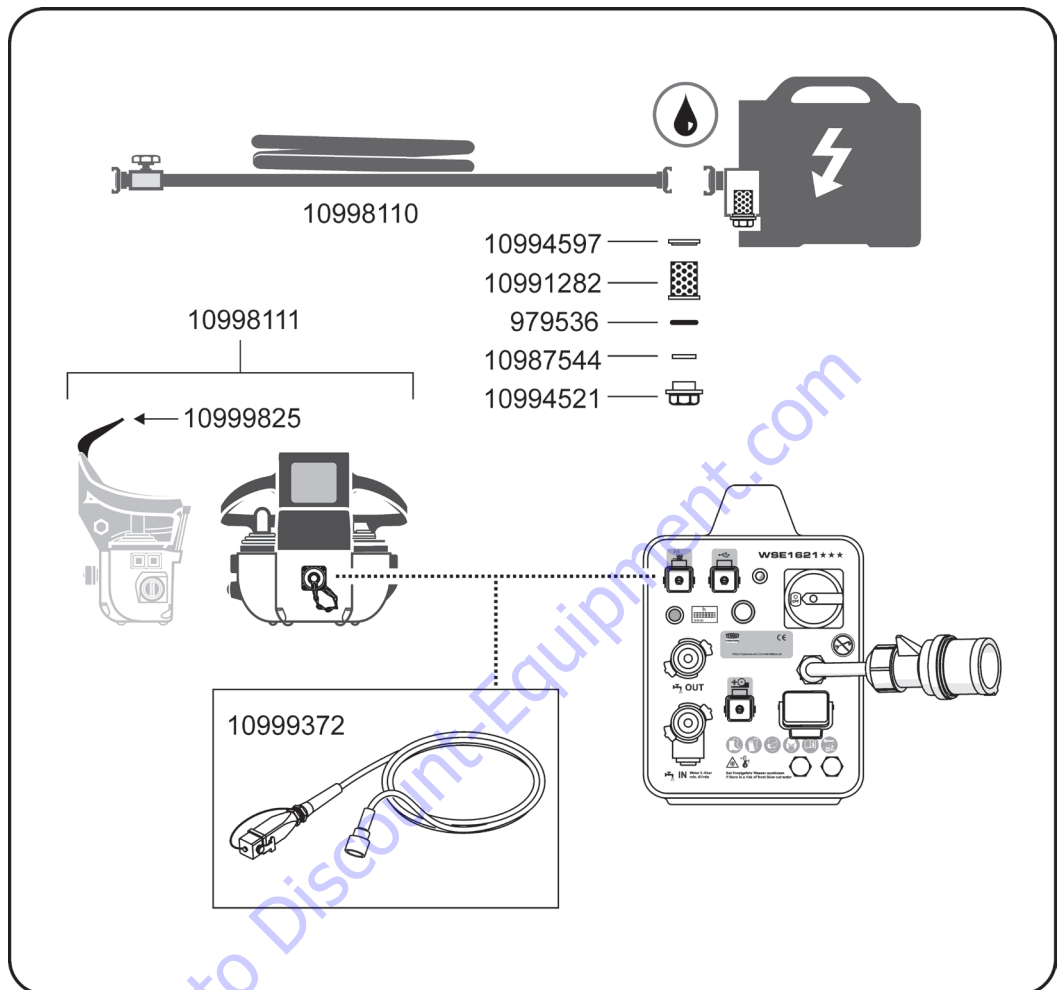

**TO PURCHASE THIS PRODUCT PLEASE CONTACT US**



**Equipment Financing and  
Extended Warranties Available**



**Discount-Equipment.com is your online resource for  
commercial and industrial quality parts and equipment sales.**

**561-964-4949**

**visit us on line @ [www.discount-equipment.com](http://www.discount-equipment.com)**

Select an option below to find your Equipment

**Search by Manufacturer**

**Search by Product Type**

**Request a Quote**

We sell worldwide for the brands: Genie, Terex, JLG, MultiQuip, Mikasa, Essick, Whiteman, Mayco, Toro Stone, Diamond Products, Generac Magnum, Airman, Haulotte, Barreto, Power Blanket, Nifty Lift, Atlas Copco, Chicago Pneumatic, Allmand, Miller Curber, Skyjack, Lull, Skytrak, Tsurumi, Husquvarna Target, Stow, Wacker, Sakai, Mi-T-M, Sullair, Basic, Dynapac, MBW, Weber, Bartell, Bennar Newman, Haulotte, Ditch Runner, Menegotti, Morrison, Contec, Buddy, Crown, Edco, Wyco, Bomag, Laymor, EZ Trench, Bil-Jax, F.S. Curtis, Gehl Pavers, Heli, Honda, ICS/PowerGrit, IHI, Partner, Imer, Clipper, MMD, Koshin, Rice, CH&E, General Equipment, Amida, Coleman, NAC, Gradall, Square Shooter, Kent, Stanley, Tamco, Toku, Hatz, Kohler, Robin, Wisconsin, Northrock, Oztec, Toker TK, Rol-Air, APT, Wylie, Ingersoll Rand / Doosan, Innovatech, Con X, Ammann, Mecalac, Makinex, Smith Surface Prep, Small Line, Wanco, Yanmar



[www.Discount-Equipment.com](http://www.Discount-Equipment.com)

To order go to [Discount-Equipment.com](http://Discount-Equipment.com)