

# EXTREME DUTY BUDDY Mortar Mixer



Models: EXD850, EXD1100, EXD1300



## EXTREME DUTY BUDDY MIXER OPERATOR MANUAL

America's Fastest & Strongest Mortar Mixers

4541-3 St. Augustine Rd. • Jacksonville, FL 32207  
Office / Warehouse 888-823-8819 • 904-398-3133  
Fax: 800-548-1333 • 904-398-6820

[www.buddyequipment.com](http://www.buddyequipment.com)



**BUDDY EQUIPMENT, INC.**  
**AMERICA'S FASTEST & STRONGEST MORTAR MIXERS.**

**LIMITED WARRANTY** ..... 5

**FOREWORD / WARRANTY INFORMATION** ..... 6

**SECTION 1 - INTRODUCTION** ..... 7-9

    Introduction ..... 8

    Intended Use ..... 8

    General Description ..... 8-9

    Machine Diagram ..... 10

**SECTION 2 - TECHNICAL DATA** ..... 11-16

    Machine Specifications ..... 12

    Lubrication Specifications ..... 12

    Engine Specifications ..... 13

    Machine Sound Level Test ..... 13

    Machine Dimensions ..... 14

    Operator Controls ..... 15

    PIN & Plate Location ..... 16

**SECTION 3 - HEALTH & SAFETY** ..... 17-24

    Decal Location ..... 18-19

    Safety Precautions ..... 20-23

    Safety Use ..... 24

**SECTION 4 - OPERATION** ..... 25-35

    General Safety Notes ..... 26-27

    Safety Symbols ..... 28

    Delivery Inspection ..... 28

    Break-In Period ..... 28

    Before Starting ..... 28-29

    Pre-Start Checklist ..... 30

    Fuel ..... 30

    Starting the Machine ..... 31

    To Operate Machine ..... 31-32

    Shutting the Machine Off ..... 33

    Operator Controls ..... 33

    Towing ..... 33-35

**SECTION 5 - MAINTENANCE** ..... 36-48

    First Service 50 Hours ..... 38

    Additional Service Information ..... 38

    Fluids and Lubrication ..... 38-39

    Lubrication Points ..... 40

**TABLE OF CONTENTS**

**EXTREME DUTY  
BUDDY  
MORTAR MIXER**

# TABLE OF CONTENTS

Engine/Engine Oil/Air Filter .....	40
Spark Plug / Engine RPM/Cooling System/Valve Clearance .....	41
Hardware .....	42
Wheel Bearing Lubrication .....	42
Wheel Bearing Adjustment .....	42
Drum Seals .....	42
Cleaning .....	42
Storage/Long-Term Storage/End of Storage .....	43
Troubleshooting .....	44
Maintenance Chart .....	45
Maintenance Log .....	46
Seals and Bearings .....	47
Bull Gear Assembly .....	48

**CALIFORNIA PROPOSITION 65 WARNING .....** IBC

**EXTREME DUTY  
BUDDY  
MORTAR MIXER**

## LIMITED WARRANTY

The Manufacturer warrants that products manufactured shall be free from defects in material and workmanship that develop under normal use for a period of 1-year for products from the date of shipment. The foregoing shall be the exclusive remedy of the buyer and the exclusive liability of the Manufacturer. Our warranty excludes normal replaceable wear items, i.e. gaskets, wear plates, seals, O-rings, V-belts, drive chains, clutches, etc. Any equipment, part or product which is furnished by the Manufacturer but manufactured by another, bears only the warranty given by such other manufacturer. The Manufacturer extends the warranty period to 2-years on the drum, "Lifetime" for the drum bearings and seals for the mortar mixers, and agrees to furnish, free of charge, the bearings and seals only upon receipt of the defective parts. A Warranty Evaluation Form must accompany all defective parts. Warranty is voided by product abuse, alterations, and use of equipment in applications for which it was not intended, use of non-manufacturer parts, or failure to follow documented service instructions. The foregoing warranty is exclusive of all other warranties whether written or oral, expressed or implied. No warranty of merchantability or fitness for a particular purpose shall apply. The agents, dealer and employees of Manufacturer are not authorized to make modification to this warranty, or additional warranties binding on Manufacturer. Therefore, additional statements, whether oral or written, do not constitute warranty and should not be relied upon.

The Manufacturer's sole responsibility for any breach of the foregoing provision of this contract, with respect to any product or part not conforming to the Warranty or the description herein contained, is at its option (a) to repair, replace or refund such product or parts upon the prepaid return thereof to location designated specifically by the Manufacturer. Product returns not shipped prepaid or on an economical transportation basis will be refused (b) as an alternative to the foregoing modes of settlement - the Manufacturer's dealer to repair defective units with reimbursement for expenses, except labor, and be reviewed with the Manufacturer prior to repair. A Warranty Evaluation Form must accompany all warranty claims.

Except as set forth hereinabove and without limitation of the above, there are no warranties or other affirmations which extends beyond the description of the products and the fact hereof, or as to operational efficiency, product reliability or maintainability or compatibility with products furnished by others. In no event whether as a result of breach of contract or warranty or alleged negligence, shall the Manufacturer be liable for special or consequential damages including but not limited to: Loss of profits or revenues, loss of use of the product or any associated product, cost of capital, cost of substitute products, facilities or services or claims of customers.

No claim will be allowed for products lost or damaged in transit. Such claims should be filed with the carrier within fifteen days.

Effective October 2006.

Buddy Equipment, Inc.  
4541-3 St. Augustine Rd.  
Jacksonville, FL 32207  
Local: (904) 398-3133 or 888-823-8819  
Fax: 800-548-1333

# FOREWORD

## Location of warranty information:

1. Information on S/N tag.
2. Information on engine tag.
3. Date you purchased machine.
4. Dealer machine was purchased from.

**EXTREME DUTY  
BUDDY  
MORTAR MIXER**

These instructions include:

- Safety regulations
- Operating instructions
- Maintenance instructions

- **These instructions have been prepared for operation on the construction site and for the maintenance engineer.**
- These instructions are intended to simplify operation of the machine and to avoid malfunctions through improper operation.
- Observing the maintenance instructions will increase the reliability and service life of the machine when used on the construction site and reduce repair costs and down-times.
- **Always keep these instructions at the place of use of the machine.**
- **Only operate the machine as instructed and follow these instructions.**
- **Observe the safety regulations as well as the guidelines of the civil engineering trade association.**
- Buddy Equipment, Inc. is not liable for the function of the machine when used in an improper manner and for other than the intended purpose.
- Operating errors, improper maintenance and the use of incorrect operating materials are not covered by the warranty.
- The above information does not extend the warranty and liability conditions of business of Buddy Equipment, Inc.

---

Please enter the following data. This will help expedite any service or warranty work.

1. Machine Type: \_\_\_\_\_

Machine S/N: \_\_\_\_\_

2. Engine Type: \_\_\_\_\_

Engine S/N: \_\_\_\_\_

3. Purchase Date: \_\_\_\_\_

4. Dealer/Distributor Information:

Name: \_\_\_\_\_

Address: \_\_\_\_\_

Phone #: \_\_\_\_\_

Fax # \_\_\_\_\_

**EXTREME DUTY  
BUDDY  
MORTAR MIXER**

# **1. INTRODUCTION**

## INTRODUCTION



This safety alert system identifies important safety messages in this manual.

When you see this symbol, be alert, your safety is involved. Carefully read the message that follows and inform other operators.

**EXTREME DUTY  
BUDDY  
MORTAR MIXER**

## INTRODUCTION

---

Congratulations on your purchase of the Buddy Mixer! You've made an excellent choice! Buddy mixers have been specifically designed as the ideal machine for the professional contractor. The Buddy Mixer is ergonomically engineered to optimize operator interface with the total machine--it's really "user friendly". Besides good visibility, you'll find that the controls are exactly in the right places for maximum comfort and safety.

Our common sense approach to servicing is a valuable benefit on the BUDDY MIXER. Thanks to our modular design, everything that needs servicing is located behind the easy-access cowl.

The following instructions were compiled to provide you information on how to obtain long and trouble-free use of the mixer. Periodic maintenance of the mixer is essential. Read the manual in its entirety and follow the instructions carefully. Refer to the Technical Data Section to familiarize yourself with machine controls and components. Failure to do so may injure yourself or a bystander.

## INTENDED USE

---

These machines are designed to carry out the function of mixing mortar, plaster, fireproofing, grout and other small grained Portland cement products.

Use of the machine in any other way is considered contrary to the intended use and will void the warranty.

**Danger Zone**

While the machine is in use unauthorized persons must remain outside the danger zone.

## GENERAL DESCRIPTION

---

Your new EXD850, EXD1100, OR EXD1300 mixer comes standard with the following patented features:

### Patented Drum and Paddle Design

The symmetrical drum shape eliminates the dead-zone and increases the mixer's speed by up to 30%.

**The paddle design:**

- Increases the level of entrained air which then lowers the mortar's temperature by up to 5 degrees.
- Proven longer pan life
- Makes the mix more creamy...improving spreadability
- Extends the mortar's plasticity, which allows a longer time period before tooling the mortar.
- Improves spreadability and extends the workability which allows you to lay more courses before tooling.



## Patent Pending Engine Cowl Design

- This unique engine cowl allows access to the engine's controls without having to open the cowl.
- This allows the mixer to be operated with the cowl closed...convenience of not having to open and close the cowl for engine starting and stopping.
- The front section of the engine cowl becomes a closed compartment housing the mixer's drive train components.
- Provides the highest level of operating safety.
- Protects the drive train components from cement dust and dirt thus extending the component's life.

## Extendible and Lockable Axle---with the Patent Pending "Locking-Leg"

- Utilizing the optional "Locking-Leg" the mixer can be protected from jobsite theft by removing the dump side wheel / spindle and replacing it with the locking-leg.
- The axle can be collapsed from the 46 inches standard towing width to less than 36 inches total width making maneuvering around the worksite and through doorways possible.

## Quadruple Shaft Seal

Provides a life-long urethane seal system that completely isolates the sealed ball bearings in the drum trunnions from the mix.

## Patented Automatic Guard Lifter

Lifts the drum guard as the drum is tilted to prevent the mix from being poured through the guard and causing a build up on it. The guard and guard lifter system is designed for your safety and convenience.

## Engine

The engine is a high quality 8hp or 11hp Honda with low oil shut down to protect the engine from the harshest environments.

**EXTREME DUTY  
BUDDY  
MORTAR MIXER**

# INTRODUCTION

## MACHINE DIAGRAM

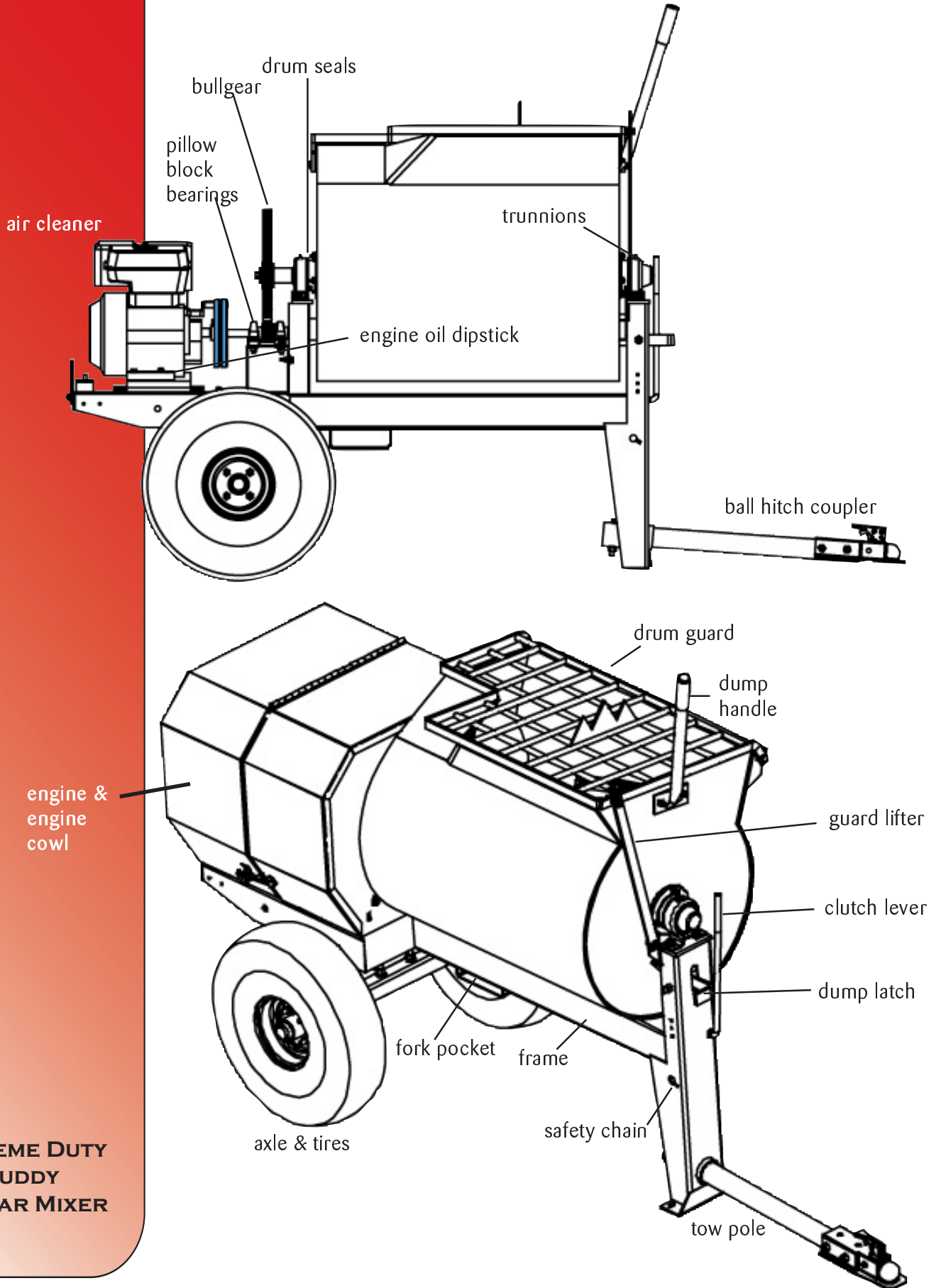

**EXTREME DUTY  
BUDDY  
MORTAR MIXER**

**EXTREME DUTY  
BUDDY  
MORTAR MIXER**

## **2. TECHNICAL DATA**

# TECHNICAL DATA

## Extreme Duty Buddy Mortar Mixers - Specifications

Model	Buddy EXD850	Buddy EXD1100	Buddy EXD1300
<u>Dimensions</u>			
Operating Wt. Lbs/kg	796 / 361	860 / 389	1084 / 492
Total Volume cu.ft. / cu. m.	8.6 / 0,24	11.1 / 0,31	15.8 / 40,1
Lx W x H in / cm	95.50 x 48 x 68 243 x 122 x 173	100.50 x 48 x 68 255 x 122 x 173	125 x 56 x 71.5 317,5 x 142 x 182
Discharge Height in / cm	17.63 / 44,8	17.63 / 44,8	15.8 / 40,1
<u>Engines</u>			
	8 hp Honda 2 hp Baldor 1-PH 115/230V 3 hp Baldor 1-PH 230V	8 hp Honda 2 hp Baldor 1-PH 115/230V 3 hp Baldor 1-PH 230V	11 hp Honda 3 hp Baldor 1-PH 230V

## Lubrication Specifications

	Type	Quantity
Engine Crankcase qts / liter	See Engine Manual	1.16 / 1.1
Grease Fittings oz / mm	Mobilgrease XHP 222 (NLGI 2EP lithium complex)	3-4 / 90-120

**EXTREME DUTY  
BUDDY  
MORTAR MIXER**

## TECHNICAL DATA

### Engine Specifications

Engine Type	Single Cylinder, 4-Cycle Air Cooled Gasoline	Electric Motor
Engine Make	Honda	Baldor
Engine Model	GX240, GX340	ODP
Power	8 hp / 6,0 kw 11 hp / 8,2 kw	2 hp / 1,5 kw 3 hp / 2,2 kw
Operating Speed Idle / Full RPM	1400 / 3600 no load +/- 100	1725 RPM
Fuel Type	Unleaded Gasoline, High Test Minimum 91 Octane	115V 1-PH, 230V 1-PH

### Machine Sound Level Test

Machine Type	Buddy Mixer EXD1100
Sound Level Meter Calibration Date	May 26, 2005
Meter Type	Simpson Model 886-2 Type 2
Test Date	November 27, 2006
Test Conditions	
Temperature	46 degrees Fahrenheit
Ambient Sound	dba fast mode
Soil Condition	silts and clay
Moisture Limit	Approximately equal to 50%
Engine Speed	3,600 RPM
Frequency	4,000 Hz
Test Site	Honeoye, New York USA
Sound Level at Operator Position	dba 95



Since the permissible noise level rating of 89 dB(A) can be exceeded with this machine, the operator must wear suitable hearing protection!

**EXTREME DUTY  
BUDDY  
MORTAR MIXER**

# TECHNICAL DATA

## MACHINE DIMENSIONS

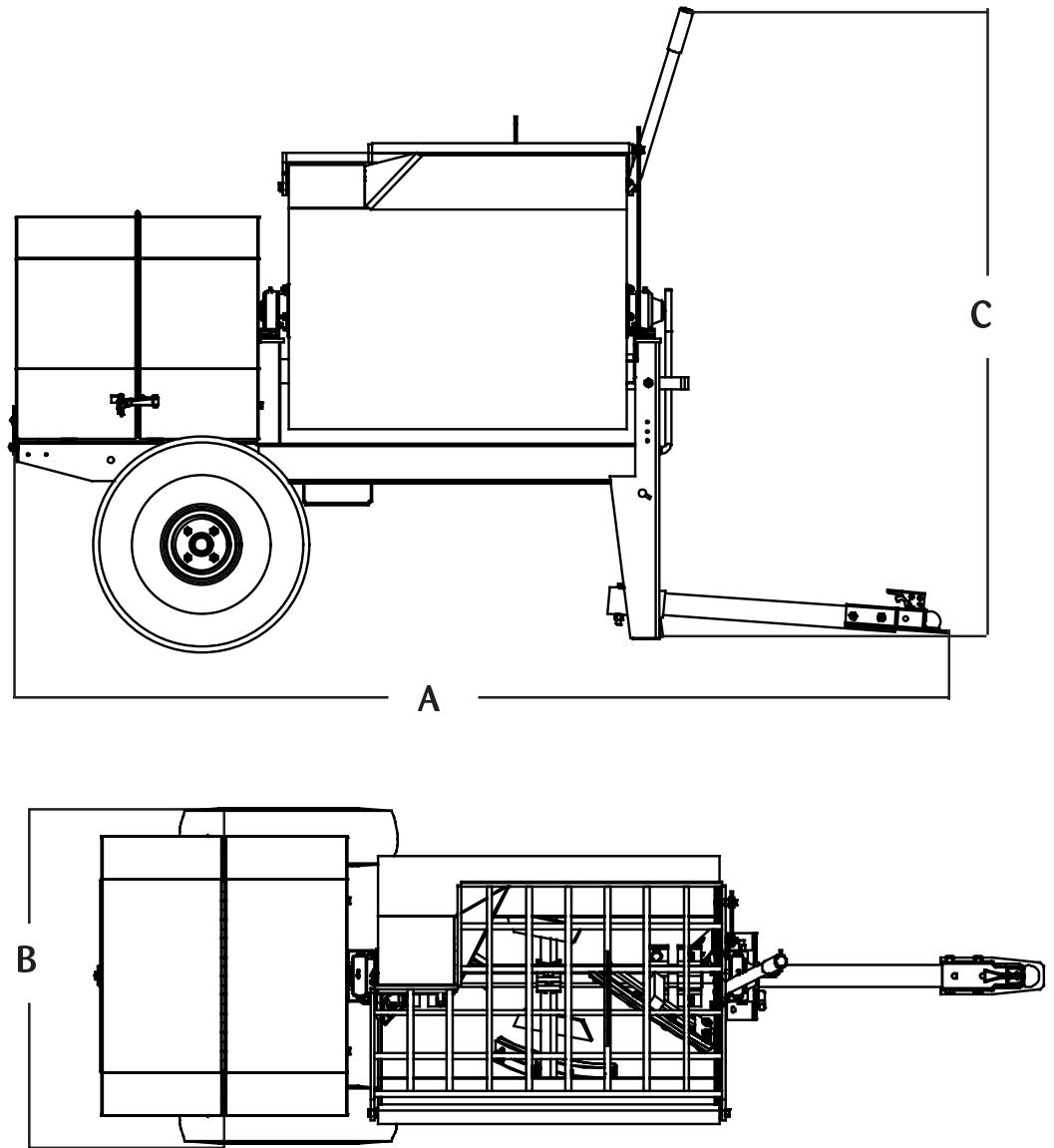

Dimensions	A Length	B Width (axle retracted)	C Height
EXD850 L x W x H in / cm	95.50 / 243	47 / 119 (35.68 / 90,6)	68.0 / 173
EXD1100 L x W x H in / cm	100.5 / 255	47 / 119 (35.68 / 90,6)	68.0 / 173
EXD1300 L x W x H in / cm	125 / 318	56.5 / 144	71.5 / 182

**EXTREME DUTY  
BUDDY  
MORTAR MIXER**

## MACHINE OPERATOR CONTROLS

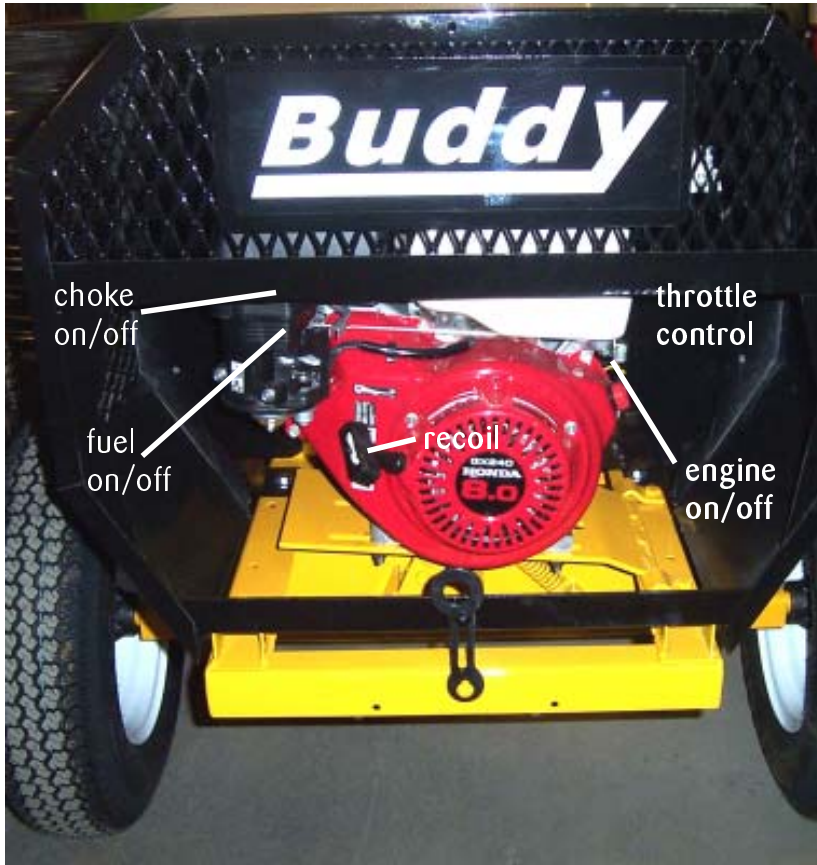

## TECHNICAL DATA

**EXTREME DUTY  
BUDDY  
MORTAR MIXER**

# TECHNICAL DATA

## PIN & PLATE LOCATION

---

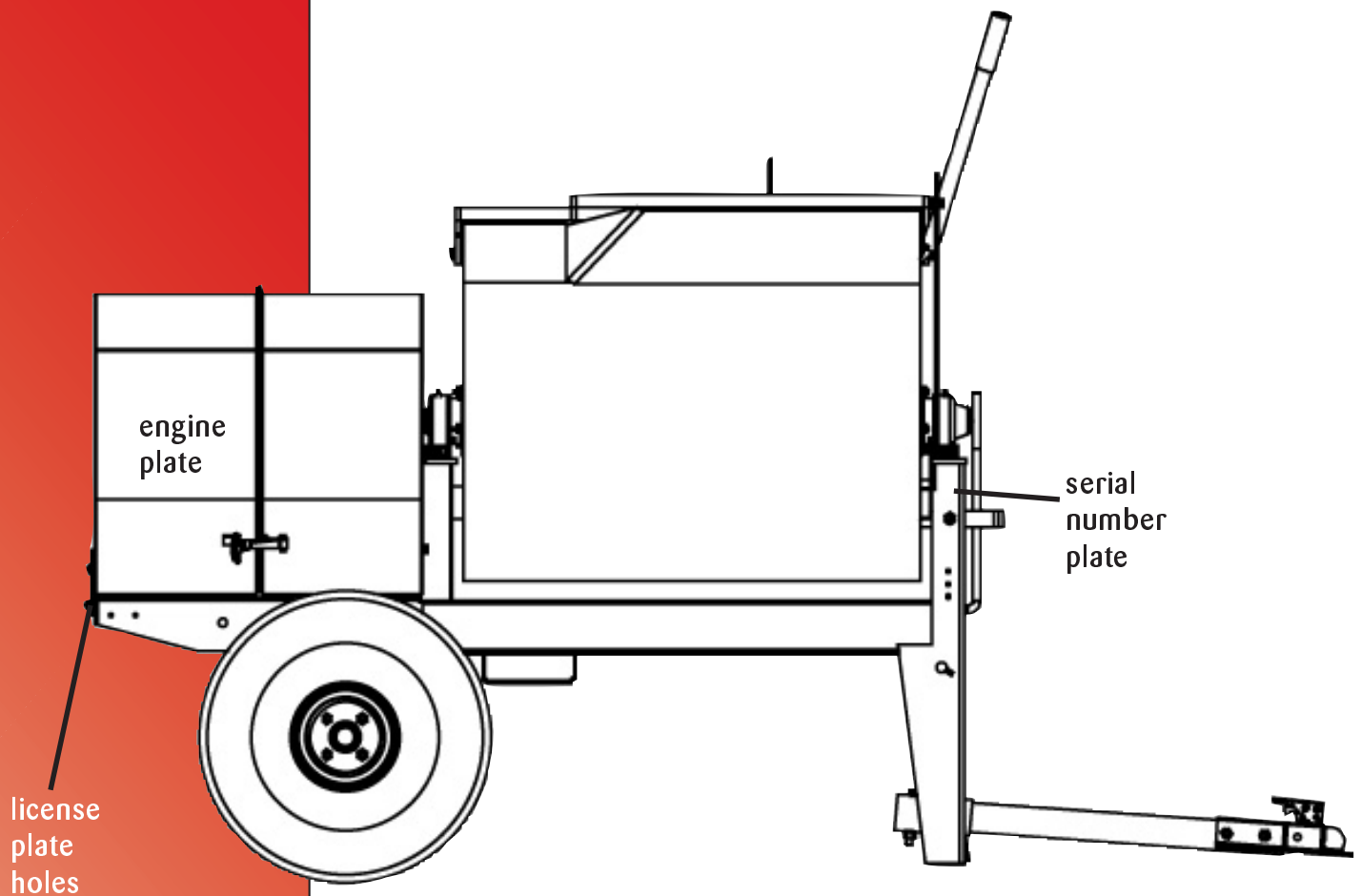

**EXTREME DUTY  
BUDDY  
MORTAR MIXER**



EXTREME DUTY  
BUDDY  
MORTAR MIXER

### **3. HEALTH & SAFETY**



# Front View - Decal Placement

## HEALTH & SAFETY

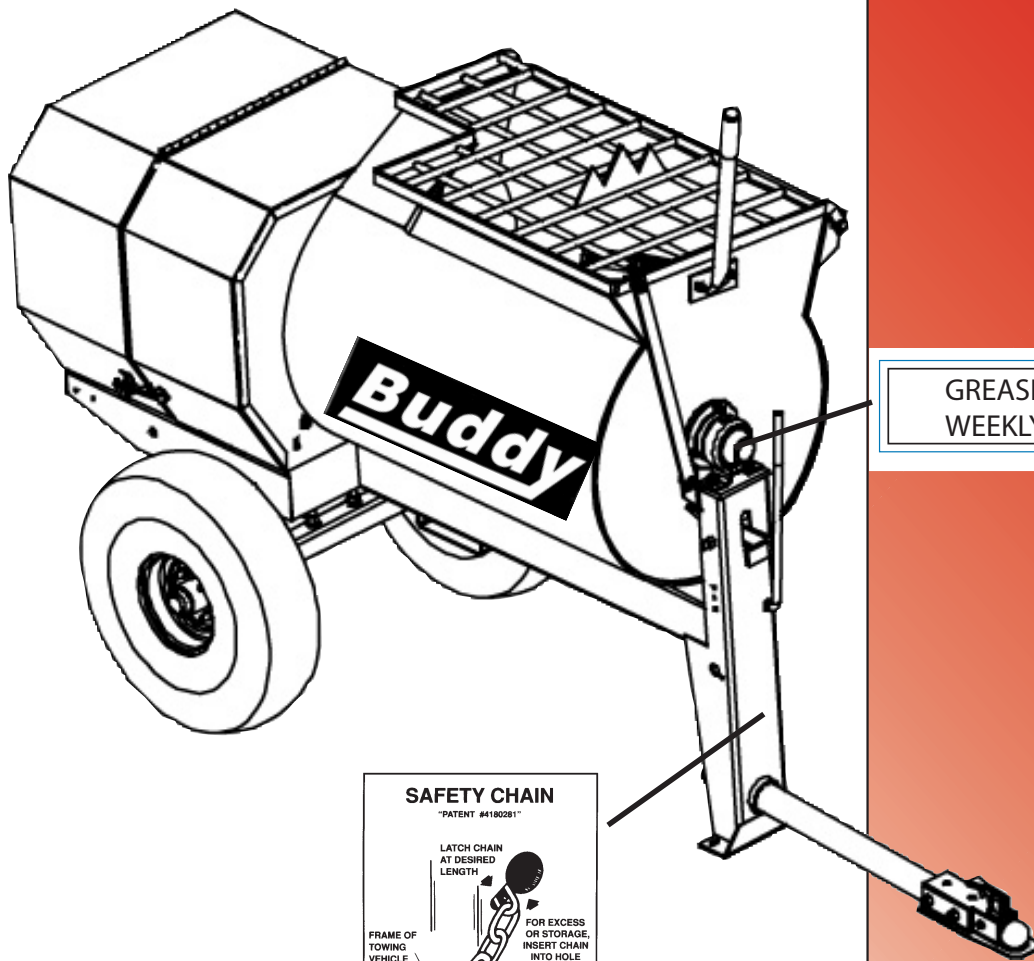

GREASE WEEKLY 55392

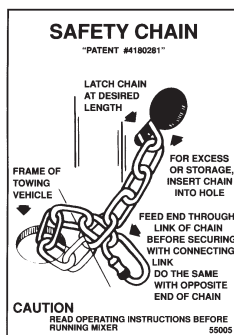

EXTREME DUTY  
BUDDY  
MORTAR MIXER

## HEALTH & SAFETY

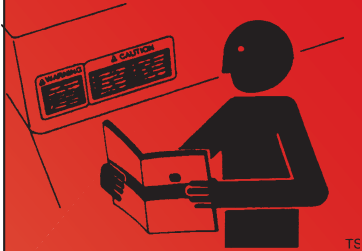

**! WARNING**



**EXTREME DUTY  
BUDDY  
MORTAR MIXER**

## FOLLOW SAFETY INSTRUCTIONS

---

- Carefully read all safety messages and decals in this manual and on your machine safety signs. Keep decals in good condition. Replace missing or damaged decals. Be sure new equipment components and repair parts include the current safety signs. Replacement safety signs and decals are available through your dealer.
- Learn how to operate the machine and how to use controls properly. Do not let anyone operate without instruction.
- Keep your machine in proper working condition. Unauthorized modifications to the machine may impair the function and/or safety and affect machine life.
- If you do not understand any part of this manual and need assistance, contact your dealer.

## UNDERSTAND SIGNAL WORDS

---

- A signal word – DANGER, WARNING, or CAUTION – is used with the safety-alert symbol. DANGER identifies the most serious hazards.
- DANGER or WARNING safety signs are located near specific hazards. General precautions are listed on CAUTION safety signs. IMPORTANT also calls attention to safety messages in this manual.
- This notation appears before warnings in the text. It means that the step that follows must be carried out to avoid the possibility of personal injury or death. These warnings are intended to help the technician avoid any potential hazards encountered in the normal service procedures. We strongly recommend that the reader takes advantage of the information provided to prevent personal injury or injury to others.

## PRACTICE SAFE OPERATION

---

- Users must be trained to operate this mixer. Read the Operator's Manual and Engine Owner's Manual. Learn to operate this mixer safely.
- Before starting machine, make sure that there are no persons or obstacles near or under machine.
- Do not operate the mixer in standing water.
- Ear protection required when operating this equipment.
- Exposure to loud noise can cause impairment or loss of hearing.
- For foot protection, wear steel toe shoes or toe pads.
- Never perform any work on mixer while it is running.
- Before working on mixer, stop the engine and disconnect the spark plug wire(s) to prevent accidental starting. If electric, unplug motor.
- Keep cowl closed and latched during operation, close and latch cowl immediately after starting.
- Keep hands, clothing and jewelry away from all moving parts.
- Keep all guards in place, including drum guards.
- Never place your hands or any solid object into drum while mixer is in operation.

## PROPER VENTILATION

---

- Never operate unit in a poorly ventilated or enclosed area.
- Avoid prolonged breathing of exhaust gases.
- Engine exhaust fumes can cause sickness or death.

## WEAR PROTECTIVE CLOTHING

---

- Wear close fitting clothing and safety equipment appropriate to the job.
- Prolonged exposure to loud noise can cause impairment or loss of hearing.
- Wear a suitable hearing protective device such as earmuffs or earplugs to protect against objectionable or uncomfortable loud noises.
- Operating equipment safely requires the full attention of the operator. Do not wear radio or music headphones while operating machine.

## HOT SURFACES

---

- Muffler, engine, and engine shroud may be hot.
- Allow all components in the engine compartment to cool before performing any service work.

## PRACTICE SAFE MAINTENANCE

---

- Understand service procedure before doing work. Keep area clean and dry.
- Never lubricate, service or adjust machine while it is moving. Keep hands, feet, and clothing from power-driven parts. Disengage all power and operation controls to relieve pressure. Stop the engine. Allow machine to cool.
- Securely support any machine elements that must be raised for service work.
- Keep all parts in good condition and properly installed. Fix damage immediately. Replace worn or broken parts. Remove any buildup of grease, oil, or debris.
- Never perform any work on the mixer while it is running. Before working on the mixer, stop the engine and disconnect the spark plug wire(s) to prevent accidental starting, block drums to prevent rolling.
- Keep engine cover closed during the operation.
- Keep all guards in place.

## HEALTH & SAFETY



**EXTREME DUTY  
BUDDY  
MORTAR MIXER**

## HEALTH & SAFETY



**DANGER**



**BEFORE TOWING**



**Environment**



**EXTREME DUTY  
BUDDY  
MORTAR MIXER**

### WARNING-TOWING

---

- Warning: Before attempting to tow mixer, ensure that all anti-theft devices are disabled and completely removed. Always close fuel valve.
- Warning: Do not tow the mixer with the drum in the dump position. Mixer may become unstable and tip over when hitting a curb, pothole or other obstruction.
- Warning: Always properly attach safety chains before mixer is towed. Maximum towing speed 55 m.p.h. (90 km/hr). Reduce speed according to highway conditions.

### WARNING-BEFORE TOWING

---

1. Check vehicle hitch, ball and coupler for signs of wear or damage. Replace any parts that are worn or damaged before towing.
2. Use only the ball diameter indicated on your coupler. Use of any other ball diameter will create an extremely and dangerous condition that can result in separation of the coupler and ball or ball failure.
3. Be sure the coupler is secured to the hitch ball and the lock lever is down tight and locked. Assure that the ball clamp is properly nested under the ball and not sitting on top of the ball. Recheck tightness again after towing about 50 miles.
4. Check that trailer safety chains are properly connected.
5. Check that all trailer lighting is hooked up and working correctly.

### DISPOSE OF WASTE PROPERLY

---

- Improperly disposing of waste can threaten the environment and ecology. Potentially harmful waste used with equipment include such items as oil, fuel, coolant, brake fluid, filters, and batteries.
- Use leak proof containers when draining fluids. Do not use food or beverage containers that may mislead someone into drinking from them.
- Do not pour waste onto the ground, down a drain, or into any water source.
- Inquire on the proper way to recycle or dispose of waste from your local environmental or recycling center.

### WARNING - EYE PROTECTION

---

- Always wear splash goggles when operating equipment.

## USE COMMON SENSE WHEN HANDLING FUELS

---

- Transport and handle fuel only when contained in approved safety containers.
- Do not smoke when refueling the engine or during any other fuel handling operation.
- If fuel is spilled during refueling, wipe it off from the engine immediately and discard the rag in a safe place.
- Do not operate the equipment if fuel or oil leaks exist-repair immediately.
- Never operate this equipment in an explosive atmosphere.
- Starting fluid (ether) is highly flammable, do not use or an explosion or fire may result.

## PREPARE FOR EMERGENCIES

---

- Be prepared if a fire starts.
- Keep a first aid kit and fire extinguisher handy.
- Keep emergency numbers for doctors, ambulance service, hospital, and fire department near your telephone.

## LOOSE HARDWARE

---

- With power off, DAILY check for loose hardware. Immediately inform your supervisor to have it corrected--Do Not Run Mixer.

## EXTENSION CORDS

---

- Always use the proper size grounded extension cord, conforming to the National Electric Code and Local Ordinances.
- Inspect all extension and electrical cords for cuts, frayed wire and broken connectors before use. Do not use cords if not in good condition.
- Do not route extension cords through standing water.
- Do not operate the mixer in standing water.
- When cleaning the mixer, never spray water over the motor.

## HEALTH & SAFETY

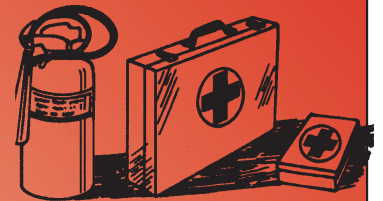

**EXTREME DUTY  
BUDDY  
MORTAR MIXER**

## **HEALTH & SAFETY**

### **SAFETY USE**

These machines are designed to carry out the function of mixing mortar, plaster, fireproofing, grout and other small grained Portland cement products.

If used correctly, they will provide an effective and safe means of mixing and meet the appropriate performance standards.

It is essential that the operator of the machine is adequately trained in its safe operation, be authorized to operate it, and have sufficient knowledge of the machine to ensure that it is in full working order before being put to use.

**EXTREME DUTY  
BUDDY  
MORTAR MIXER**



EXTREME DUTY  
BUDDY  
MORTAR MIXER

## 4. OPERATION

## GENERAL SAFETY NOTES

---

---

### If Applicable, Observe the Following Points for Your Safety and Protection

---

Operators and maintenance personnel must always comply with the following safety precautions. These precautions are given here for your safety. Review them carefully before operating the machine and before performing general maintenance or repairs. Supervising personnel should develop additional precautions relating to specific work area and local safety regulations.

- Before operating the machine, ensure you have had proper training and are fully conversant with the machine and its operation - If in Doubt ASK!
- Read this instruction manual carefully before operating the machine. Ensure this instruction manual is kept with the machine at all times and in good condition - replace the manual immediately if it becomes dirty, damaged or lost.
- Decals are fitted to the machine for safety purposes and **MUST** be replaced immediately if they are not readable or lost. If the machine is repaired and parts have been replaced on which decals were fixed, ensure new decals are fitted before the machine is put into service.
- Always make sure there is a adequate ventilation around the machine. Never run the engine in an enclosed area without good ventilation or next to combustible materials.
- Stop the engine before refuelling. If there is a spillage, mop it up and do not start the engine until it is safe again.
- The exhaust gets extremely hot. Do not place anything on top of it and keep all combustible materials clear. Do not attempt any maintenance on a hot engine.
- Check your local laws, the engine may require a spark arrester etc.
- Do not inspect or clean the machine with the engine running.
- Make sure you and anyone else who uses the machine have been shown how to operate it safely.
- A hard hat, safety boots, safety glasses and reflective clothing must be worn at all times.
- Establish a training program for all operators to ensure safe operation.
- Do not operate the machine unless thoroughly trained.
- Do not operate the machine if it is damaged, improperly adjusted or not completely and correctly assembled.

## PREVENT DAMAGE TO MACHINE

---

---

### Observe the Following Points, If Applicable, to Prevent Damage to the Machine

---

- Always replace parts with parts supplied or recommended by Buddy Equipment. NEVER USE SPARE PARTS OF INFERIOR SPECIFICATION.
- Never allow unqualified people to perform repairs on the machine.
- Never overfill the engine oil or fuel tank.
- If a hose bursts, stop the engine immediately - ALWAYS replace with a hose of the correct specification.
- Follow the engine starting instructions in this manual and on the machine.
- If you see oil leaking, report it and get it fixed immediately.
- Make sure the correct fuel, oils and grease are used.
- Never use the machine for purposes other than those it was manufactured for.
- Always ensure workmates are aware of your work plan.
- If equipped, ensure all tires are serviceable before using the machine.
- Do not operate the machine if it is damaged, improperly adjusted or not completely and correctly assembled.
- Establish a training program for all operators to ensure safe operation.

**OPERATION**

**EXTREME DUTY  
BUDDY  
MORTAR MIXER**

## OPERATION



This symbol is used to identify an action that requires particular attention and/or care.

**EXTREME DUTY  
BUDDY  
MORTAR MIXER**

## SAFETY SYMBOLS

---

Safety symbols are used in these instructions to bring attention to actions that may cause personal injury or damage to the equipment. Always observe these symbols, they are included for your safety and for the protection of the machine.

## DELIVERY INSPECTION

---

Upon receipt of your mixer, **CAREFULLY CHECK FOR ANY FREIGHT DAMAGE.** Any damage should be immediately reported to the carrier and a claim registered.

This unit is manufactured to the strictest specifications and inspection procedures. If any material or manufacturing defects are found, return the tag on the machine with the assembler's signature and your findings to the manufacturer. We want to know when a product is less than perfect. We also welcome any and all input on how the product may serve you better.

The following instructions were compiled to provide you information on how to obtain long and trouble free use of the mixer. Periodic maintenance of the mixer is essential. Read the manual in its entirety and follow the instructions carefully. Refer to the Technical Data Section to familiarize yourself with machine controls and components. Failure to do so may injure yourself or a bystander.

## BREAK-IN PERIOD

---

The BUDDY MIXER is ready for normal operation. However, extra care during the first 50 hours of operation will result in more satisfactory, long-term machine performance and cost of ownership. Do not exceed 50 hours of operation before conducting the break-in first service.

- Run engine at full throttle.
- Run engine under load. DO NOT overload the engine.
- Idle engine 3 minutes before stopping.
- DO NOT idle engine for long periods.
- Check engine oil level daily.

## BEFORE STARTING

---

**READ ENGINE OWNERS MANUAL.** Mixers are shipped completely assembled and ready for operation except for installation of the safety chain.

### Safety Chain Installation

1. Remove the safety chain kit from the engine compartment. The kit includes (1) 12 ft. length of safety chain and (2) latch hooks.
2. Pull one end of the chain through the (2) key hole slots located in the front post of the mixer with a hook (see drawing below and decal on mixer front post).
3. Attach the latch hooks to each end of the chain.
4. Follow the instructions in the TOWING section of this manual and on the mixer front post to attach the safety chain to the towing vehicle.

## Installing Chain to Mixer

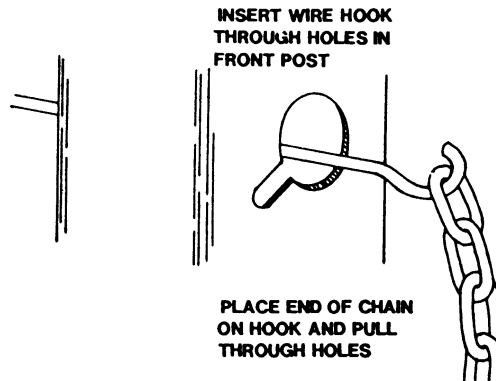

## Dump Handle Installation

Remove the dump handle from the mixer drum where it is attached to the paddle shaft. Consult the **FRAME AND DRUM ASSEMBLY** section of this manual and use the (2) 3/8 bolts and nuts provided near the top, tow pole end of the drum to install the drum handle as shown in the exploded view. Assemble nuts to the outside of the drum. Do not torque bolt that holds the guard - see note in the **TORQUE CHART** section of this manual.

## Oil Levels and Lubrication

Be sure to check the oil levels in the engine and engine reduction unit **BEFORE** starting this unit. The engine warranty is **VOID** if it is run without oil. Consult the **ENGINE MANUAL** supplied with this unit for specific instructions and oil recommendations.

## Axle Blocks (Spring Axle Option Only)

Before your mixer was shipped, wood blocks were placed in the axle springs to avoid bouncing during transport. Before operation, loosen spring bolts, remove blocks and retighten spring bolts until locknut is fully engaged.

## Rubber Blades

The rubber blades are factory preset. Due to local preferences, some readjustment may be desired.

## Check Drum Dump Latch

Make sure that the drum latch is engaged with the drum in the upright or mixing position.

Review the following information. Specific information regarding these items can be found in the Technical Data Section or located by the Table of Contents. The following instructions were compiled to provide you information on how to obtain long and trouble free use of the mixer. Periodic maintenance of the mixer is essential. Read the manual in its entirety and follow the instructions carefully. Refer to the Technical Data Section to familiarize yourself with the machine controls and components. Failure to do so may injure you or a bystander.

# OPERATION

**EXTREME DUTY  
BUDDY  
MORTAR MIXER**

## OPERATION

Fuel is highly flammable, handle with care. Do not refuel the engine while smoking or when near an open flame or sparks. Always stop engine before refueling. Clean up spilled fuel before starting. Avoid fires by keeping engine clean of accumulated grease and debris.

Do not run unit in an enclosed, unventilated area. Avoid prolonged breathing of exhaust gases.

### PRE-START CHECKLIST

---

- Review the manual and check that operator and engine controls function properly before starting.
- Check engine oil level. **Warranty is VOID if run without oil.** Consult the Engine Manual supplied with this unit for specific instructions and oil recommendations.
- Check engine air filter.
- Check engine fuel level.
- Check hardware for looseness. If loose, tighten according to torque chart.



### **WARNING**

*ENGINE IS EQUIPPED WITH LOW OIL SHUT DOWN. UNIT WILL SHUT DOWN IF ENGINE OIL IS LOW.*

### FUEL

---

Always use fresh, unleaded high test gasoline (91 octane min). Fresh gasoline is blended for the season and reduces gum deposits that could clog the fuel system. Do not use gasoline left over from the previous season. The engine has a separate oil reservoir in the crankcase. Do not mix oil with the fuel. Unleaded gasoline is recommended for use in the engine since it leaves less combustion chamber deposits. Never tow mixer with fuel valve open.

### **WARNING**

*FUEL IS BOTH TOXIC AND FLAMMABLE. DO NOT SMOKE WHILE WORKING WITH FUEL. DO NOT USE NEAR OPEN FLAME. START, STORE AND REFUEL ON LEVEL GROUND TO PREVENT PERSONAL INJURY. DO NOT RUN UNIT IN AN ENCLOSED, NON-VENTILATED AREA. AVOID PROLONGED BREATHING OF VAPORS AND SKIN CONTACT. SERIOUS ILLNESS OR LOSS OF LIFE COULD RESULT.*

#### Fuel Level

Check the fuel level when the mixer is parked on level ground and the engine is off.

### **WARNING**

*SET MIXER UP IN AN OPEN AREA. AVOID CLOSE PROXIMITY TO STRUCTURES OR OTHER EQUIPMENT. FAILURE TO DO SO MAY CAUSE INADVERTENT INJURY TO OPERATOR OR OTHER PEOPLE IN THE AREA.*

**EXTREME DUTY  
BUDDY  
MORTAR MIXER**

## STARTING THE MACHINE

---

### Warm and Cold Weather Starting

1. Disengage drive train.
2. Turn engine switch to the "on position".
3. Open fuel valve.
4. Turn on choke.
5. Pull recoil until engine starts.
6. Then turn choke off gradually.
7. Always operate the engine at full speed when under load.

### Electric Motor Switch

- Located on the motor. It is used to start and stop the electric mixer.

## TO OPERATE

---

Start the engine as instructed above and allow engine to reach operating temperature. Make sure that the engine cowl is closed. **Never** operate the mixer with the cowl open. **Never** operate the mixer with the drum guard open or removed.

### Paddle Rotation

The proper rotation of paddles for mixing is clockwise rotation from the tow pole end of machine. Rotate clutch lever for paddle rotation to engage the paddles. The lever will remain in this position unless pulled and disengaged.

### Mixer Charging Sequence

1. Engage the paddles for mixing prior to charging the mixer.
2. Begin charging the mixer by pouring the required amount of water into drum.
3. Add bags of mortar mix.
4. Add the required amount of sand.
5. Add additional water if required to achieve desired mortar consistency.

Note: When using a premix tower to charge the mixer, add the total required amount of water into drum prior to adding the premix.

## OPERATION



**EXTREME DUTY  
BUDDY  
MORTAR MIXER**

## OPERATION

### **WARNING**

*THE MIXER IS DESIGNED FOR MIXING ONLY MORTAR, PLASTER, FIREPROOFING, GROUT AND OTHER SMALL GRAINED PORTLAND CEMENT PRODUCTS. ANY OTHER USE OF THIS MIXER MAY CAUSE PREMATURE FAILURE OR GREAT PERSONAL RISK TO THE OPERATOR OR OTHER INDIVIDUALS CLOSE BY. DO NOT USE FOR MIXING ANY VOLATILE OR CORROSIVE MATERIAL.*

#### **Drum Discharge**

After mixing for the proper length of time (homogenous mix obtained), discharge the mix from the drum using the dump handle.

1. Leave the mixing paddles engaged to help in the discharge of the mix.
2. Pull down drum dump handle to discharge the mix.
3. When the drum is completely discharged, pull up on the drum dump handle to retract the drum back to its mixing position.
4. Immediately pour in the required water for the next batch with the paddles continuing to mix. This will clean the paddles and drum between batches and help prevent dried lumps of mortar from forming and contaminating the next batch.

### **WARNING**

*ALWAYS WEAR SPLASH GOGGLES WHEN OPERATING THE MIXER. FAILURE TO DO SO WILL ALLOW FOREIGN PARTICLES TO ENTER EYES.*

### **WARNING**

*NEVER OPERATE MIXER WITH ANYONE CLOSE BY. KEEP ALL UNTRAINED PERSONNEL AWAY FROM WORK AREA.*

#### **Cleaning the Mixer**

For consistent performance, long life and continued high quality mixing of plaster or mortar, thoroughly clean the mixer inside and out at the end of each day's operation. To prevent lumps of dried plaster from forming and contaminating future batches of plaster or mortar, do not allow build up of materials to form on drum guards, around paddles or anywhere inside the drum.

- Before cleaning, shut the engine off and disconnect the spark plug wire to prevent accidental starting.
- Keep drum guard closed.
- Always keep guard lifter connected.
- Keep drum in upright, mixing position.
- Spray mixer with water before mix dries to remove accumulation.
- Power up mixer and rotate drum to dump position to remove debris.
- Sometimes it is necessary to strike the drum with a hammer to loosen dried mix. Above all, be careful not to dent the drum as this may damage the drum and void the warranty.

### **WARNING**

*FAILURE TO FOLLOW CLEANING INSTRUCTION AND/OR ROTATION OF DRUM WITHOUT GUARD LIFTER CONNECTED CAN RESULT IN SERIOUS INJURY.*

**EXTREME DUTY  
BUDDY  
MORTAR MIXER**



## SHUTTING THE MACHINE OFF

1. Retract drum until it is in its mixing position.
2. Disengage drive train by moving lever for paddle rotation to its neutral position.
3. To improve the engine service life, throttle engine down to idle for a period of 2 to 5 minutes before shutting down.
4. When idle period is up, use engine stop switch under gas tank to shut off engine.
5. Before towing mixer, **always close the fuel valve and turn off gas!**

## OPERATOR CONTROLS

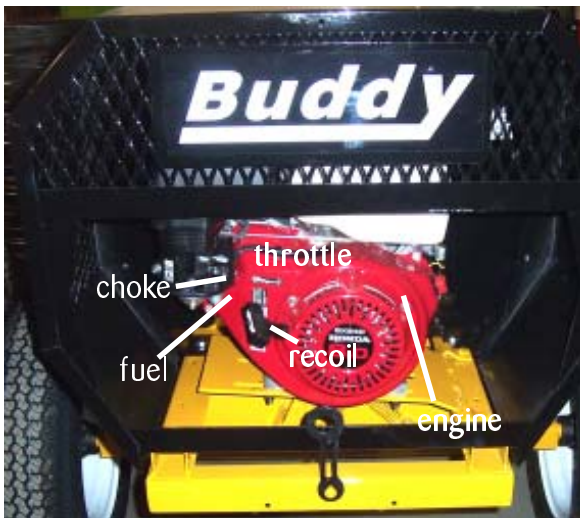

## TOWING

Before attempting to tow this mixer, always shut off fuel supply and check the state and local laws that apply to your intended route and check the following:

1. Hitch attached to the towing vehicle securely.
2. Tow pole fully extended and bolted to mixer securely.

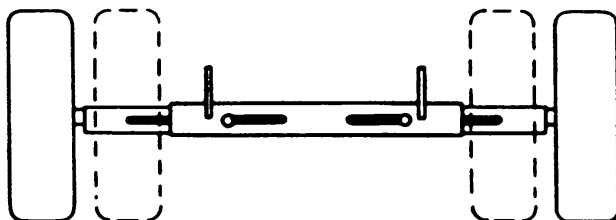

## OPERATION

**EXTREME DUTY  
BUDDY  
MORTAR MIXER**

## OPERATION

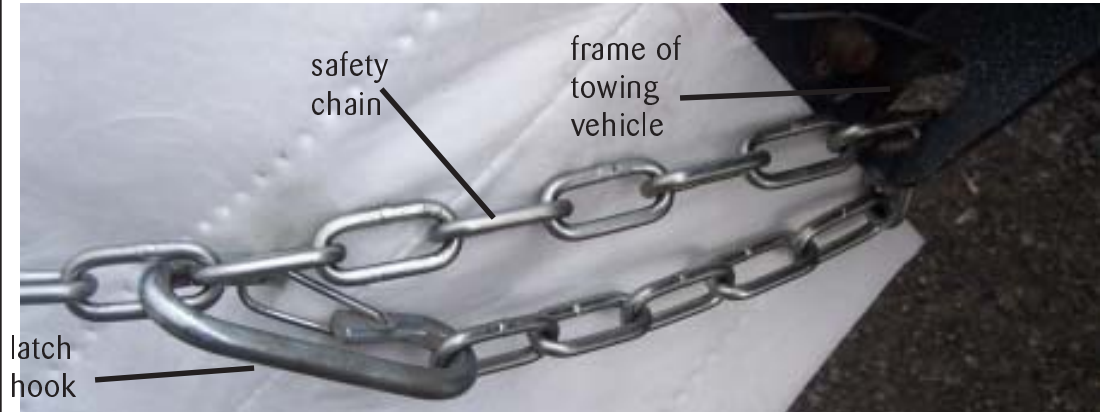

### Attach Safety Chain to Towing Vehicle

- Cross chain under tow pole with 4-5 inch vertical slack.
  - Feed chain through frame of towing vehicle.
  - Secure end of chain with latch hook as illustrated.
  - Repeat with opposite end of chain.
3. Safety chain hooked up properly (see illustration below and decal on mixer front post).
  4. Drum in the mixing position and drum latch engaged, clutch lever in the up position.
  5. Lug nuts and axle mount nuts tight.
  6. On extendible axles, extend axle to full width and adjust bolts tight.
  7. On spring axles - spring mounting hardware tight, main springs and snubber springs not cracked or broken.
  8. Tires in good shape and at proper inflation, for maximum safety and load capacity tires should be inflated to the following pressures:

Tire size 6.50 x 13 @ 32 P.S.I.



**EXTREME DUTY  
BUDDY  
MORTAR MIXER**

## **WARNING**

9. On Spring Axles--wheel spindle on mixer dump end of machine is pinned to axle with two pins and secured with two hairpins. Make sure that spindle is fully assembled into axle and both pins are locked in place as shown prior to towing.

## **WARNING**

***FAILURE TO PIN SPINDLE INTO AXLE CAN RESULT IN SERIOUS DAMAGE OR INJURY.***



***DO NOT EXCEED A TOWING SPEED OF 55 MILES/HR (90 KM/HR). FOR POOR ROAD CONDITIONS OR INCLEMENT WEATHER, REDUCE SPEED ACCORDINGLY.***

Refer to FRAME AND DRUM ASSEMBLY, STANDARD AXLE ASSEMBLY and SPRING AXLE ASSEMBLY sections of the Parts Manual for parts identification and location.

### ***Recommended Coupler Maintenance*** ***Read Entire Owners Manual***

1. Smear ball socket and clamp face with chassis grease. Periodically, oil pivot points and sliding surfaces of coupler with SAE 30 wt. motor oil.
2. When parking or storing your trailer, keep the coupler off the ground so dirt will not build up in the ball socket.
3. Replacement instructions:
  - Use (2) 1/2 inch grade 5 through bolts and locknuts, torque to 57 ft. lbs.

**OPERATION**

**EXTREME DUTY  
BUDDY  
MORTAR MIXER**



EXTREME DUTY  
BUDDY  
MORTAR MIXER

## 5. MAINTENANCE

## FIRST SERVICE 50 HOURS

---

After the 50 hour break-in period, perform the following services:

- Change the engine oil (See Engine Oil section).
- Check air filter (see Engine Air Filter section)

## ADDITIONAL SERVICE INFORMATION

---

This is not a detailed engine service manual. If you want more detailed service information refer to engine manuals:

**IMPORTANT:** Read engine Emission Warranty Statement and Engine Manual before operating or performing maintenance.

## FLUIDS AND LUBRICATION

---

### Engine Oil

Straight SAE 30 API SH or SJ (oil with “starburst” certification mark) is recommended for general, all temperature use. Check daily for proper oil level; replace engine oil every 100 hours. **DO NOT OVERFILL.** See Engine Owner’s Manual for specifications.

### WARNING

***ENGINE IS EQUIPPED WITH LOW OIL SHUT DOWN. UNIT WILL SHUT DOWN IF ENGINE OIL IS LOW.***

### Gasoline Fuel

Always use fresh, unleaded high test gasoline (91 octane min). Fresh gasoline is blended for the season and reduces gum deposits that could clog the fuel system. Do not use gasoline left over from the previous season. The engine has a separate oil reservoir in the crankcase. Do not mix oil with the fuel. Unleaded gasoline is recommended for use in the engine since it leaves less combustion chamber deposits. At the end of the day, close the fuel valve.

Fill fuel tank at the end of each day’s operation to prevent condensation in the tank. Drain and flush fuel tank every 1000 hours or 12 months.

Avoid storing fuel over long periods of time.

Proper fuel storage is critically important. Use clean storage and transfer tanks. Periodically drain water and sediment from bottom of tank. Store fuel in a convenient place away from buildings.

**EXTREME DUTY  
BUDDY  
MORTAR MIXER**

**⚠ WARNING**

*FUEL IS BOTH TOXIC AND FLAMMABLE.*

*DO NOT SMOKE WHILE WORKING WITH FUEL.*

*DO NOT USE NEAR OPEN FLAME.*

*ALWAYS STOP ENGINE BEFORE REFUELING.*

*CLEAN UP SPILLED FUEL BEFORE STARTING.*

*AVOID FIRES BY KEEPING ENGINE AND ENGINE COWL CLEAN AND FREE OF ACCUMULATED GREASE AND DEBRIS.*

*START, STORE AND REFUEL ON LEVEL GROUND TO PREVENT PERSONAL INJURY.*

*DO NOT RUN UNIT IN AN ENCLOSED, NON-VENTILATED AREA.*

*AVOID PROLONGED BREATHING OF VAPORS AND SKIN CONTACT—SERIOUS ILLNESS OR LOSS OF LIFE COULD RESULT.*

**MAINTENANCE**

**EXTREME DUTY  
BUDDY  
MORTAR MIXER**

## MAINTENANCE

## LUBRICATION POINTS

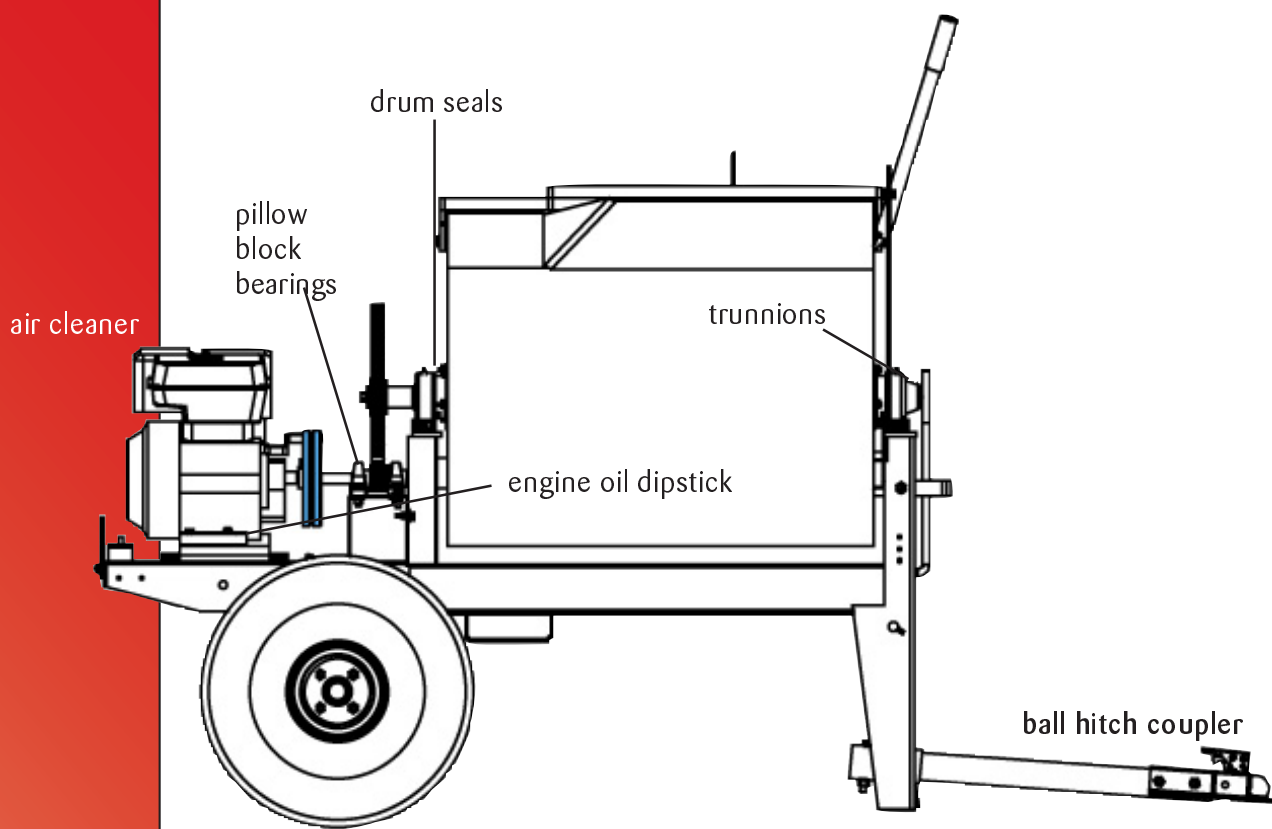

### Engine

Refer to engine manual for specific engine information.

### Engine Oil

1. Replace oil at 20 hours, then change oil every 100 hours. Under heavy loads, change engine oil weekly.
2. Remove the oil filler cap and drain bolt. Drain oil into a suitable container
3. Clean and install the drain bolt, tighten securely.
4. Fill with recommended oil, fill to the upper limit mark on the dipstick, and tighten the oil filler cap securely.
5. Run engine for 2 – 3 minutes, stop engine and check oil level and check for leaks.

Note: Please dispose of used motor oil in a manner that doesn't harm the environment.

## **▲WARNING**

**ENGINE IS EQUIPPED WITH LOW OIL SHUT DOWN. UNIT WILL SHUT DOWN IF ENGINE OIL IS LOW.**

**EXTREME DUTY  
BUDDY  
MORTAR MIXER**



## Air Filter

Wash the parts with water and dry thoroughly. Remove the pre-cleaner cap to access the foam pre-cleaner and paper element.

Clean foam pre-cleaner in warm soapy water, rinse and dry thoroughly. Apply oil to the foam and squeeze out excess oil. The engine will smoke if too much oil is left in the foam.

Clean the paper element by tapping the element lightly on a hard surface to remove excess dirt or blow pressurized air (30psi max) through the filter from the air cleaner cover side. Do not brush the dirt off.

Reassemble the cleaned air cleaner components. Replace elements if damaged or excessively dirty.

## Spark Plug

The recommended spark plug is a BPR6ES (NGK) or W20EPR-U (DENSO). To ensure proper engine operation, the spark plug must be properly gapped and free of deposits. Clean and replace at scheduled maintenance. Clean engine before removing spark plug. Visually inspect the spark plug and discard if insulator or tip is damaged. Check that the spark plug washer is in good condition. If spark plug is to be reused, clean with a wire brush and set gap .028-.031in(.70-.80mm). Thread the spark plug in by hand to prevent cross threading. After the spark plug is seated, tighten with a spark plug wrench to compress the washer.

- If installing a new spark plug, tighten ½ turn after the spark plug seats to compress the washer.
- If reinstalling a used spark plug, tighten 1/8 to ¼ turn after the spark plug seats to compress the washer.

Note:

- The spark plug must be securely tightened. An improperly tightened spark plug can become very hot and may cause engine damage.
- Use only the recommended spark plug or equivalent. A spark plug that has an improper heat range may cause engine damage.

## Engine RPM

- Start the engine and allow it to warm up to normal operating temperature, check the idle speed 1400 +/- 100, and adjust the idle stop screw as required.
- Check the full speed 3600 +/-100 and adjust the full speed stop screw as required.

## Cooling System

The machine should be cleaned at scheduled maintenance. This should include cleaning the air inlet screens and the engine cooling fins. Wash machine with warm soapy water, rinse off mud and dirt with water, and use pressurized air(30psi max) to blow dirt and debris from engine.

## Valve Clearance

Due to special tool requirements and training, an authorized engine dealer should perform this service unless the owner has the proper tools and proper shop manuals.

**EXTREME DUTY  
BUDDY  
MORTARMIXER**

## MAINTENANCE

### Hardware

Periodically inspect all hardware on the mixer and engine. Loose hardware can contribute to early component failure and poor performance.

**NOTE:** Some hardware is used to retain parts that have to move freely for correct operation of this unit. These items include the guard lifter and drum guard. The hardware for these items should be snug enough to prevent excessive play, yet loose enough to allow the parts to pivot freely.

### Wheel Bearing Lubrication

Fill wheel hub with grease to inside diameter of outer races and also fill hub grease cap. Never use grease heavier than 265 A.S.T.M. penetration (No. 2 grade). Grease bearing cone by machine or by hand method. Force grease between rollers, cone and cage. (If Ball Bearing Hub: force grease between balls.) It is not recommended that a pressure grease fitting be installed on the hub.

### Wheel Bearing Adjustment

Tighten the adjusting nut with a 12" wrench, at the same time turn the wheel in both directions, until there is a slight bind to be sure all bearing surfaces are in contact. Then back off adjusting nut 1/6 to 1/4 turn or to the nearest locking hole to allow the wheel to rotate freely within limits of 0.001 inch to 0.010 inch end play. Lock nut at this position.

### Drum Seals

Grease zerks daily with lithium based grease.

## CLEANING

---

### WARNING

**FAILURE TO FOLLOW CLEANING INSTRUCTION AND/OR ROTATION OF DRUM WITHOUT GUARD LIFTER CONNECTED CAN RESULT IN SERIOUS INJURY.**

For consistent performance, long life and continued high quality mixing of plaster or mortar, thoroughly clean the mixer inside and out at the end of each day's operation. To prevent lumps of dried plaster from forming and contaminating future batches of plaster or mortar, do not allow build up of materials to form on drum guards, around paddles or anywhere inside the drum.

**DO NOT** beat on the drum with a shovel, hammer or other device to break up accumulations of dried mix, as this will dent and damage the drum.

- Before cleaning, shut the engine or motor and disconnect the spark plug wire or electric cord to prevent accidental starting.
- Keep drum guard closed.
- Always keep guard lifter connected.
- Keep drum in upright, mixing position.
- Spray mixer with water before mix dries to remove accumulation.
- Rotate drum to dump position to remove debris.

**EXTREME DUTY  
BUDDY  
MORTAR MIXER**

## STORAGE / LONG-TERM STORAGE

---

### Cleaning and Storage

If equipment is taken out of operation for the Winter season or a prolonged period, follow below procedures to prevent machine or engine damage.

1. Ensure that the drum is in the dump position with engine off.
2. Completely clean mixer per cleaning instruction.
3. Drain the fuel system and fill it with the preservative fuel. If preservative fuel is not used, the system can be kept full with normal fuel, but the fuel must be drained and discarded at the end of the storage period.
4. Remove the air filter. Seal the vent pipe of the fuel tank or the fuel fill cap with waterproof tape.
5. With the fuel valve closed, allow the engine to "run-out". This will ensure that the fuel bowl is dry.

## MAINTENANCE

**EXTREME DUTY  
BUDDY  
MORTAR MIXER**

Symptom	Cause	Corrective Action
<b>Engine Lacks Power</b>	Fuel line plugged	Clean or replace
	Dirty fuel filter	Clean or replace
	Air filter dirty	Clean or replace
	Worn cylinder and piston rings	Replace
	Too much oil in crankcase	Drain to proper level
<b>Oil Consumption</b>	Worn valve guides	Replace
	Worn cylinder and piston rings	Replace
	Too much oil in crankcase	Drain to proper level
	Loose bolts on engine crankcase	Tighten
<b>Blue Smoke</b>	Worn valves/valve guides	Replace
	Worn cylinder and piston rings	Replace
	Too much oil in crankcase	Drain to proper level
	Oil seal at intake valve defective	Replace
<b>Does Not Start</b>	Empty fuel tank	Fill tank
	Run/ off switch is in OFF position	Move switch to proper position
	Low oil	Add Oil
<b>Paddles will not move</b>	Belts loose	Tighten belts
<b>Unit lacks power</b>	Engine not properly warmed up	Idle about five (5) minutes to reach operating temperature
	Fuel restriction	Change filter

**EXTREME DUTY  
BUDDY  
MORTAR MIXER**



## IMPORTANT!

The person attempting any of the following maintenance tasks must be authorized to do so and have read *and* understood *all* sections within this manual.

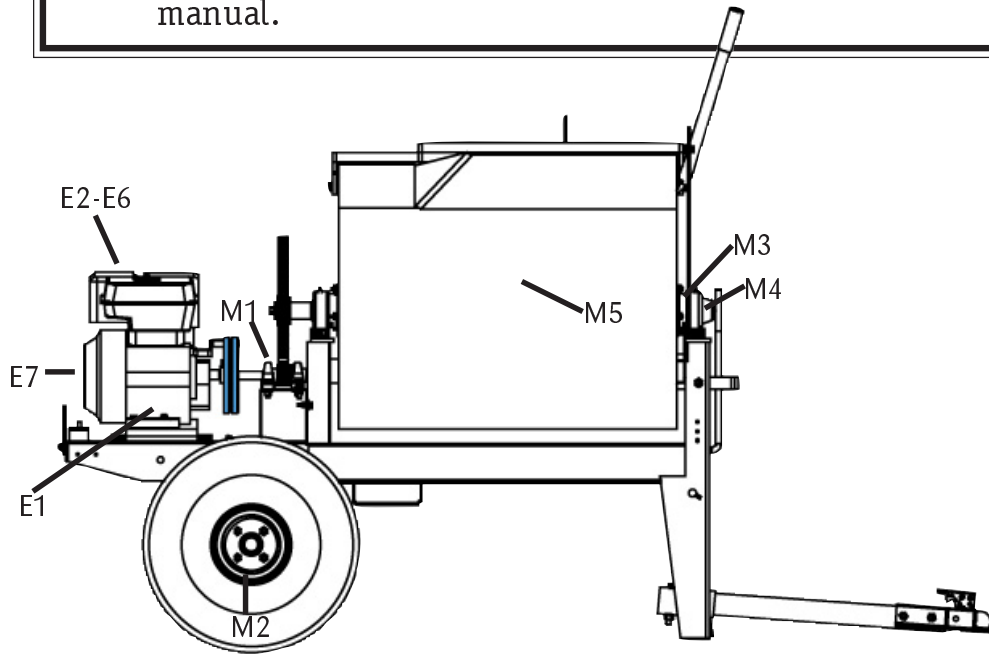

## MAINTENANCE

✓ 0	Check/Adjust Clean/Replace	Daily	Weekly	Other	Instructions
	<b>ENGINE</b>				<b>READ EMISSION WARRANTY, OPERATOR &amp; ENGINE MANUAL</b>
E1	Oil Level	✓		0	Replace at 30-hrs, then every 100-hrs SAE 30W AP, SH or SJ
E2	Fuel Cap & Strainer	✓		0	Check daily, clean every 6-months or 100 hrs
E3	Sediment Cup & Filter			0	Clean every 100-hrs
E4	Air Filter & Pre-cleaner	✓		0	Clean every 50-hrs, replace every 300-hrs
E5	Spark Plug			0	Clean every 100-hrs, gap setting .028 inch, replace every 300-hrs
E6#	Engine RPM Idle/Full			✓	Check idle at full speed RPM every 300-hrs
E7	Clean Cooling System		✓	0	Clean/blow out air inlets, engine fins (30 psi max)
E8##	Valve Clearance			✓	Check/adjust every 300-hrs
E9	Fuel Tank			0	Clean every year or 300-hrs
	<b>MACHINE</b>				
M1	Pillow Block Bearings			0	Lithium Base Grease every 50-hrs or every month
M2	Wheel Hubs			0	Repack yearly with Wheel Bearing Grease
M3	Drum Seals	✓			Grease fittings with Lithium Base Grease
M4	Trunnions		✓		Grease fittings with Lithium Base Grease
M5	Mixer Clean	0			Clean mixer inside & out/remove all build-up
M6	Leaks Oil & Fuel	✓			Clean unit and inspect
M7	Hardware/Engine Mounts	✓			Clean unit and check torque
#	Important READ Engine Emissions Warranty Statement, Manual and Engine Manual				
##	See AUTHORIZED Engine Service Dealer and/or Refer to Engine Shop Manual for Procedures				

**EXTREME DUTY  
BUDDY  
MORTARMIXER**

# MAINTENANCE

## MAINTENANCE LOG

### Extreme Duty Buddy Mortar Mixers – Maintenance Log

Machine Model \_\_\_\_\_ Date of Purchase \_\_\_\_\_

Serial Number \_\_\_\_\_ Engine Serial Number \_\_\_\_\_

Use this chart to record dates of service and hours on machine.

Maintenance	Date/ Hours	Date/ Hours	Date/ Hours	Date/ Hours	Date/ Hours	Date/ Hours	Date/ Hours
Replace Oil							
Replace Spark Plug							
Replace Engine Fuel Strainer							
Clean Air Filter							
Replace Air Filter							
Check Engine RPM							
Clean Cooling System							
Check / Adjust Valve Clearance							
Grease Pillow Block Bearings							
Grease Wheel Hubs							
Grease Drum Seals							
Grease Trunnions							
Clean Machine							

**EXTREME DUTY  
BUDDY  
MORTAR MIXER**

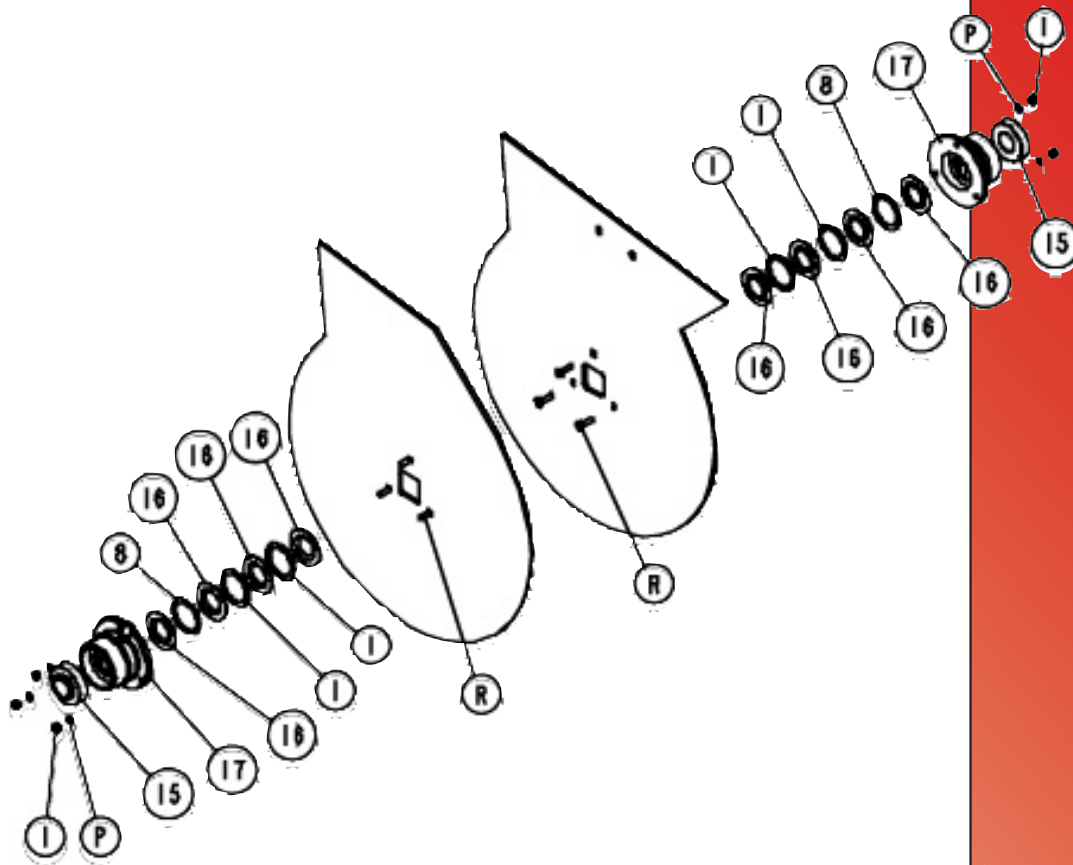

Instructions for Seal & Bearing Assembly Kits P/N 23432

ITEM	P/N	DESCRIPTION	QUANTITY
1	24017	Washer	2
8	25881	Washer Split	1
15	32003	Bearing	1
16	32324	Seal Drum Yellow	4

1. Disassemble drum from frame and remove. Unscrew end bolts from paddle shaft and remove spacers and bull gear.
2. Attach a three-jaw puller to ring on housing, center puller on paddle shaft and remove housing and bearing.
3. Remove worn components and clean shaft and housing as needed.
4. Assemble seals and spacers over paddle shaft, flush with drum end using soapy water mixture as lubricant.
5. Make sure seals are assembled tight up to drum end; inner lip of seals curve inwards towards drum end as illustrated.
6. Insert bearing into housing and slide over shaft and seals as illustrated.
7. Tighten housing evenly to drum end so as not to pinch seals.
8. Reassemble spacer, bull gear (if applicable), washer and bolt to paddle shaft and repeat steps 4-7 on opposite end and reassemble drum to frame.

**EXTREME DUTY  
BUDDY  
MORTAR MIXER**

## BULL GEAR ASSEMBLY

1. Align Bull gear key way opposite to gear mesh. Never lubricate this surface.
2. Adjust pinion for tooth alignment and engagement using .010 feeler gauge.
3. Tighten all four (4) pillow block bolts before removing feeler gauge.

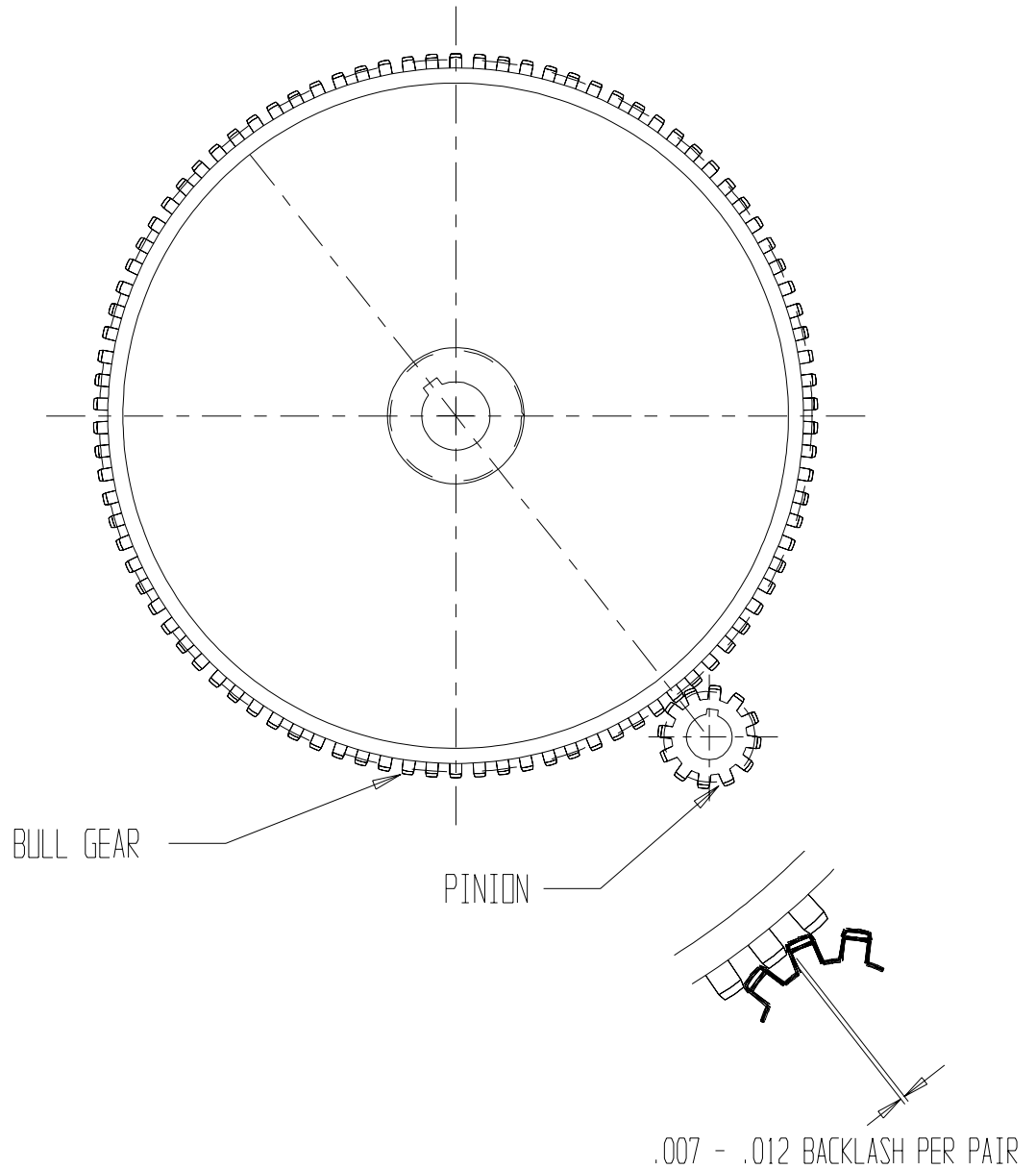

**EXTREME DUTY  
BUDDY  
MORTAR MIXER**



**EXTREME DUTY  
BUDDY  
MORTAR MIXER**

**EXTREME DUTY  
BUDDY  
MORTAR MIXER**

**CALIFORNIA PROPOSITION 65 WARNING:** Operation of this equipment and/or engine exhaust from this product contains chemicals known to the State of California to cause cancer, birth defects, and other reproductive harm.

**EXTREME DUTY  
BUDDY  
MORTAR MIXER**

America's Fastest & Strongest Mortar Mixers



Buddy Equipment, Inc.  
4541-3 St. Augustine Rd.  
Jacksonville, FL 32207  
Local: (904) 398-3133 or 888-823-8819  
Fax: 800-548-1333

© 2006 Buddy Equipment, Inc.,  
Printed in U.S.A.

SPR