

CC9074DK Deep Cut Walk Behind Saw

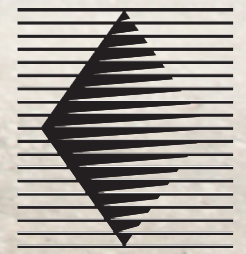

www.Discount-Equipment.com





Tier 4 Final

Powered By:

Kubota



MADE IN THE U.S.A.



Blade not included

CC9074DK Deep Cut Saw

60" Blade Capacity

Diesel

Features & Benefits:

- Certified EPA/CARB Tier 4 engine
- Advanced digital 7" display
- Smart 3 mode display screen for blade speed, engine speed, engine torque views
- Critical diagnostics functions alerts potential problems to avoid shutdown
- Blade over-speed alert
- Engine service alerts and maintenance reminders
- USB Port for quick simple updating of display software
- Digital depth indicator/stop
- Front View Camera to view sawing location/obstructions
- LED spot and bar lights for night sawing
- Adjustable blade lowering speed
- Central water control valve
- Auto Water System (AWS) automatically starts/stops water to blade when in/out of cut
- Quick set handle bars
- On-board handle bar storage
- Convenient battery access for easy charging access
- Single piece frame platform with heavy bar and tubular reinforcement
- Undercarriage slurry flap to minimize slurry buildup on rear axle components
- Tubular frame lift -central hoist location for balanced even lifting
- Effective weight balance for balanced optimum performance
- Fast attach blade guard stabilizer with quick disconnect ball joints to speed guard removal
- Steady hydrostatic pump for smooth reliable response with low speed travel creep
- Heavy duty wheels with 1" thick polyurethane tread for front and rear wheels
- Easy-turn 5th wheel that automatically lifts rear wheels at max raise height to allow rear saw swivel
- Enclosed rear wheel motors that are hydraulic driven with center swivel for easy tracking adjustment
- Simple freewheeling with dash mounted switch activation
- Robust blade shaft with massive support by 3 pillow block style, spherical roller bearings
- Powerful Jackshaft drive with low speed, high torque blade drive maximizing full engine power
- Vast 25" depth sawing with an impressive 60" blade and 10" quick disconnect flanges
- Advanced air cleaner with radial seal primary and secondary filters along with spinner style pre-cleaner
- Reliable radiator fan drive with gear driven clutch drive for strong cooling performance
- Front mounted radiator with front saw access for quick cleaning and servicing
- Robust radiator core made of heavy duty aluminum that withstands frequent power washing
- Heavy rear weight kit with improved traction for the deepest sawing
- Sealed electronic protection that resists heat, moisture, shock and vibration
- Corrosion resistant components with durable finish for harsh demanding conditions

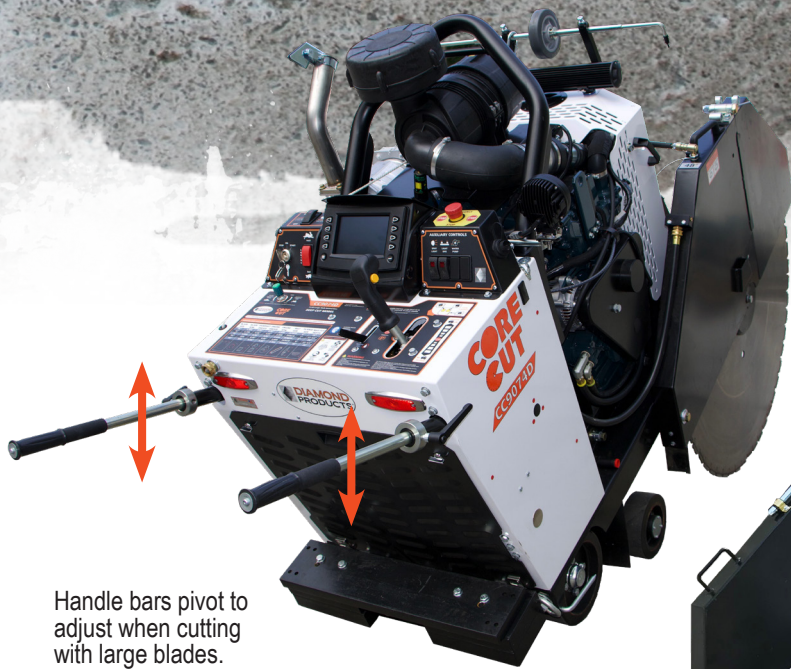

Handle bars pivot to adjust when cutting with large blades.



LED light bar for night sawing



CC9074DK Control Panel

Detailed control instructions and computer readout for blade speed and engine setting. The control panel can automatically fold down to protect the screen.

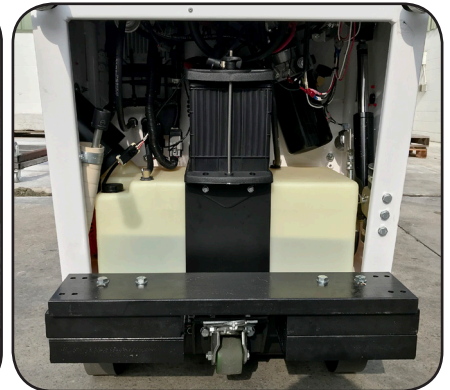

Simplified Serviceability

Easy, open component access to speed routine maintenance

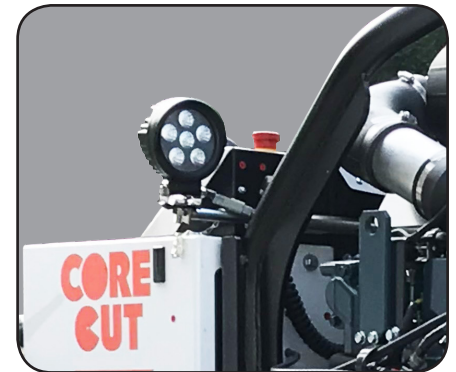
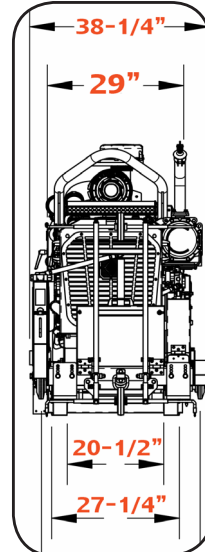
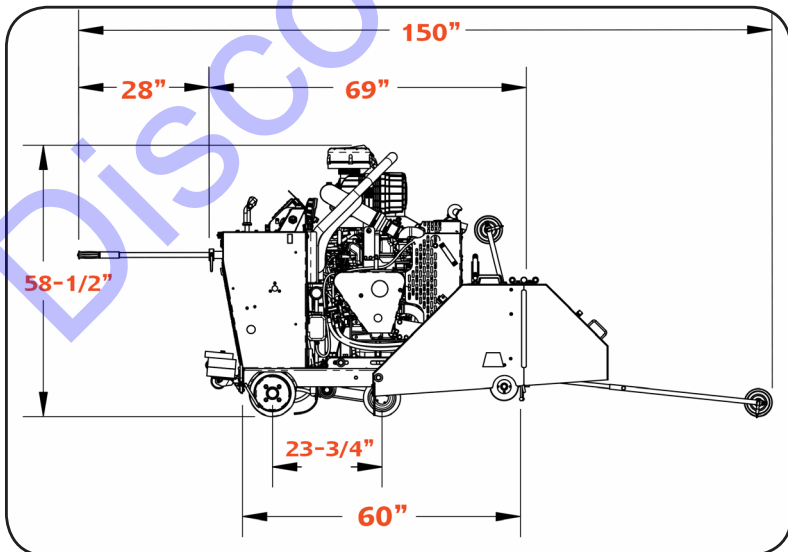

Side Spot Light

Increased lighting capability for night time or low light sawing

CC9074DK DEEP CUT SAW

Model #	Engine Make	Engine Power	Power Source	Speeds	Part #	Cat #	Product Weight (lbs.)	Blade Capacity
CC9074DK-36	Kubota® Turbo	74 HP	Diesel	Single	5801290	68055	2,489	36"
CC9074DK-42	Kubota® Turbo	74 HP	Diesel	Single	5801291	68247	2,509	42"
CC9074DK-48	Kubota® Turbo	74 HP	Diesel	Single	5801292	57696	2,518	48"
CC9074DK-54	Kubota® Turbo	74 HP	Diesel	Single	5801293	46758	2,723	54"
CC9074DK-60	Kubota® Turbo	74 HP	Diesel	Single	5801294	59724	2,773	60"

CC9074DK OPTIONS & BLADE GUARDS

Description	Part #	Cat #
Water Pump (electric)	6016035	49453
Weight Kit (200 lbs.)*	6016088	49459
36" Tapered Mount Blade Guard	6010958	13375
42" Tapered Mount Blade Guard	6010960	08216
48" Tapered Mount Blade Guard	6010962	24618
54" Tapered Mount Blade Guard	6010614	99721
60" Tapered Mount Blade Guard	6010616	70666

*Standard on the CC9074DK



Telescoping front-rear-left-right pointers with tracking adjustment

CC9074DK SPECIFICATIONS

Saw Model	CC9074DK-36	CC9074DK-42	CC9074DK-48	CC9074DK-54	CC9074DK-60
Blade Guard Capacity	36" (900mm)	42" (1000mm)	48" (1200mm)	54" (1400mm)	60" (1500mm)
Blade Cutting Depth Max.	15"	17.5"	20"	22.5"	25"
Blade Shaft Speed	1400 RPM	1150 RPM	1000 RPM	870 RPM	800 RPM
Jackshaft Sheave Size	5"	6"	6.9"	8"	8"
Engine Speed	2,600 RPM	2,600 RPM	2,600 RPM	2,600 RPM	2,400 RPM
Blade Flange Size	6" OD	7" OD	8" OD	9" OD	10" OD
Drive Belts (Set of 10)	3VX600K	3VX616K	3VX630K	3VX650K	3VX650K
Operating Weight*	2,489 lbs.	2,509lbs.	2,518 lbs.	2,723 lbs.	2,773 lbs.
Crated Weight	2,578 lbs.	2,600 lbs.	2,633 lbs.	2,923 lbs.	2,964 lbs.
Blade Guard Weight Only	63 lbs.	72 lbs.	94 lbs.	170 lbs.	200 lbs.
Rear Weight Kit Only	NA	NA	NA	200 lbs.	200 lbs.

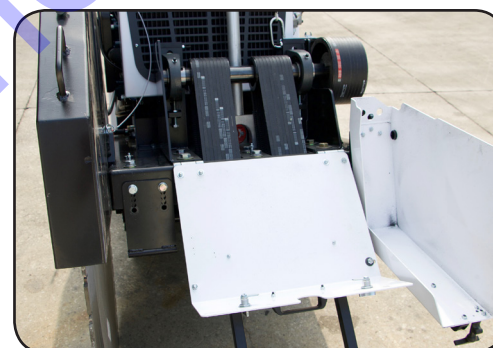

Easily Accessible Belts

Multi-panel openings for quick belt maintenance.

Standard Features:

Telescoping front and rear pointers, dual LED marker lamps, fuel and oil coolers, low coolant level sensor, oil drain valve, air restriction indicator, travel speed push/pull cable, positive front axle depth stop, slip-on blade flange guard, folding front rest, polycarbonate decals, ratcheting blade shaft wrench.

Engine Model	Kubota V3307-CR-TE4B, EPA Carb Tier 4 Final/ EU Stage III B
Engine Type	4 cylinder, liquid cooled, turbo diesel
Engine Max. Power	74.3 hp @ 2600 rpm (Kubota rating)
Emission Regulation	EPA-CARB Tier 4 Final / EU Stage III B
Engine Air Filtration	Dry dual element with spinner pre-cleaner and restriction indicator
Engine Sheave Size	4" (All Models)
Peak Torque	195.5 Ft-Lbs (265 Nm) @ 1500 rpm
Battery	12 Volt (950 CCA) group size 31
Starter / Alternator	Electric 4hp (3kW) / 90 Amp
Blade Arbor Size	1" diameter with drive pin
Blade Flange Type	Quick disconnect
Blade Shaft	1-3/4" OD with left/right side mounting, 3 pillow blocks with spherical roller bearings
Blade Shaft Drive	Engine: 10 Kevlar V-Belts (3VX) to Jackshaft: 20 Kevlar V-Belts (3VX)
Blade Coolant	Dual stainless steel multi-jet spray tubes
Blade Raise & Lower	Electro-hydraulic power unit with push button control
Blade Lowering Speed	Adjustable panel mounted flow control valve
Blade Depth Control	Electronic depth indicator and depth stop
Front Wheels	8" x 3" with 1" poly tread (sealed ball bearings)
Axle Size (Front/Rear)	Front: 1" OD straight / Rear: 1" OD tapered
Rear Wheels	10" x 3" with 1" poly tread (quick disconnect lug nuts)
Fifth Wheel	3-1/4" x 2" poly tread swivel lock caster
Travel Speed	0-220 FPM (2.5 mph) forward/reverse
Rear Wheel Transmission	Hydrostatic pump with push/pull cable control
Rear Wheel Drive	Hydraulic wheel motors with freewheel for pushing
Parking Brake	Automatic hydraulic lock at stop position
Handle Bar Adjustment	Variable extension with quick lock variable 30° angle range
Safety Alerts	Emergency stop, blade overspeed, neutral start

CC9074DK FLUIDS

Fuel Type	Ultra low sulfur diesel (Cetane 45 min)
Fuel Tank	9 gallon (34 liter) with fuel level indicator
Engine Oil	SAE 15W-40 API class CJ-4 (3 gallon/11.3 Liter)
Radiator Coolant	50/50 pre-mixed (3 gallon/11.3 Liter)
Wheel Motor Pump Fluid	SAE 15W-40 (2 Liter capacity)
Saw Lift Pump Fluid	SAE 15W-40 (2 Liter capacity)
Lubrication Type	NLGI #2 grease