

OPERATION AND PARTS MANUAL



www.Discount-Equipment.com

WHITEMAN SERIES
MODEL
WSC55 SERIES
CHEMICAL SPRAY CART
(HONDA GX160UT2LX2 GASOLINE ENGINE)

Revision #1 (08/30/19)

Original Version



THIS MANUAL MUST ACCOMPANY THE EQUIPMENT AT ALL TIMES.

P/N 49356

TO PURCHASE THIS PRODUCT PLEASE CONTACT US



**Equipment Financing and
Extended Warranties Available**



**Discount-Equipment.com is your online resource for
commercial and industrial quality parts and equipment sales.**

561-964-4949

visit us on line @ www.discount-equipment.com

Select an option below to find your Equipment

Search by Manufacturer

Search by Product Type

Request a Quote

We sell worldwide for the brands: Genie, Terex, JLG, MultiQuip, Mikasa, Essick, Whiteman, Mayco, Toro Stone, Diamond Products, Generac Magnum, Airman, Haulotte, Barreto, Power Blanket, Nifty Lift, Atlas Copco, Chicago Pneumatic, Allmand, Miller Curber, Skyjack, Lull, Skytrak, Tsurumi, Husquvarna Target, Stow, Wacker, Sakai, Mi-T-M, Sullair, Basic, Dynapac, MBW, Weber, Bartell, Bennar Newman, Haulotte, Ditch Runner, Menegotti, Morrison, Contec, Buddy, Crown, Edco, Wyco, Bomag, Laymor, EZ Trench, Bil-Jax, F.S. Curtis, Gehl Pavers, Heli, Honda, ICS/PowerGrit, IHI, Partner, Imer, Clipper, MMD, Koshin, Rice, CH&E, General Equipment, Amida, Coleman, NAC, Gradall, Square Shooter, Kent, Stanley, Tamco, Toku, Hatz, Kohler, Robin, Wisconsin, Northrock, Oztec, Toker TK, Rol-Air, APT, Wylie, Ingersoll Rand / Doosan, Innovatech, Con X, Ammann, Mecalac, Makinex, Smith Surface Prep, Small Line, Wanco, Yanmar

FUEL AND CHEMICAL EXPOSURE WARNINGS



WARNING

Gasoline engine exhaust and some of its constituents, and some dust created by power sanding, sawing, grinding, drilling and other construction activities contain chemicals known to cause cancer, birth defects and other reproductive harm.

Some examples of these chemicals are:

- Lead from lead-based paints
- Crystalline silica from bricks
- Cement and other masonry products
- Arsenic and chromium from chemically treated lumber

Your risk from these exposures varies, depending on how often you do this type of work. To reduce your exposure to these chemicals: **ALWAYS** work in a well-ventilated area, and work with approved safety equipment, such as dust masks that are specially designed to filter out microscopic particles.

SILICOSIS AND RESPIRATORY WARNINGS

! WARNING



SILICOSIS WARNING

Grinding/cutting/drilling of masonry, concrete, metal and other materials with silica in their composition may give off dust or mists containing crystalline silica. Silica is a basic component of sand, quartz, brick clay, granite and numerous other minerals and rocks. Repeated and/or substantial inhalation of airborne crystalline silica can cause serious or fatal respiratory diseases, including silicosis. In addition, California and some other authorities have listed respirable crystalline silica as a substance known to cause cancer. When cutting such materials, always follow the respiratory precautions mentioned above.

! WARNING

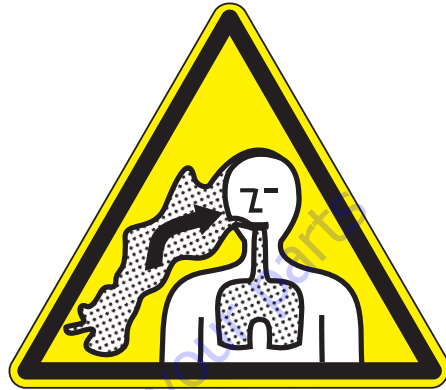

RESPIRATORY HAZARDS

Grinding/cutting/drilling of masonry, concrete, metal and other materials can generate dust, mists and fumes containing chemicals known to cause serious or fatal injury or illness, such as respiratory disease, cancer, birth defects or other reproductive harm. If you are unfamiliar with the risks associated with the particular process and/or material being cut or the composition of the tool being used, review the material safety data sheet and/or consult your employer, the material manufacturer/supplier, governmental agencies such as OSHA and NIOSH and other sources on hazardous materials. California and some other authorities, for instance, have published lists of substances known to cause cancer, reproductive toxicity, or other harmful effects.

Control dust, mist and fumes at the source where possible. In this regard use good work practices and follow the recommendations of the manufacturers or suppliers, OSHA/NIOSH, and occupational and trade associations. Water should be used for dust suppression when wet cutting is feasible. When the hazards from inhalation of dust, mists and fumes cannot be eliminated, the operator and any bystanders should always wear a respirator approved by NIOSH/MSHA for the materials being used.

TABLE OF CONTENTS

WSC55 Chemical Spray Cart

Fuel and Chemical Exposure Warnings	2
Silicosis and Respiratory Warnings	3
Table of Contents	4
Training Checklist	6
Daily Pre-Operation Checklist	7
Safety Information	8–13
Lifting and Transporting	14
Specifications	15
Dimensions	16
Noise and Vibration Emissions	17
General Information	18
Components	19–23
Set-Up	24–26
Inspection	27–28
Operation	29–34
Options	35–37
Maintenance	38–42
Troubleshooting	43–45
Explanation of Code in Remarks Column	46
Suggested Spare Parts	47

Component Drawings

Nameplate and Decals	48–49
Cart Assembly	50–51
Compressor Assembly	52–53
Pump Assembly	54–55
Engine Assembly	56–57
Wheel Assembly	58–59
Brake Assembly	60–61
Cart Hose Assembly	62–63
Barrel Mount Assembly	64–65
Engine Service Parts	66–67

NOTICE

Specifications and part numbers are subject to change without notice.

Go to Discount-Equipment.com to order your parts

NOTES

Go to Discount-Equipment.com to order your parts

TRAINING CHECKLIST

Training Checklist			
No.	Description	OK?	Date
1	Read operation manual completely		
2	Machine layout, location of components, checking of engine oil levels		
3	Fuel system, refueling procedure		
4	Operation of controls (machine not running)		
6	Unit startup, engine choke and throttle		
7	Spray system operation		
8	Compressor operation		
9	Unit shutdown		
10	Cleanup procedures		
11	Unit transport and storage		

Go to Discount-Equipment.com to order your parts

DAILY PRE-OPERATION CHECKLIST

Daily Pre-Operation Checklist		✓	✓	✓	✓	✓	✓
1	Engine oil level						
2	Fuel level						
3	Condition of hoses and fittings						
4	Compressor oil level						
5	Tire pressure						

Go to Discount-Equipment.com to order your parts

SAFETY INFORMATION

DO NOT operate or service this equipment before reading the entire manual. Safety precautions should be followed at all times while operating this equipment. Failure to read and understand the safety messages and operating instructions may result in injury to yourself and others.



SAFETY MESSAGES

The four safety messages shown below will inform you about potential hazards that could injure you or others. The safety messages specifically address the level of exposure to the operator and are preceded by one of four words: **DANGER**, **WARNING**, **CAUTION**, or **NOTICE**.

SAFETY SYMBOLS

⚠ DANGER

Indicates a hazardous situation which, if not avoided, **WILL** result in **DEATH** or **SERIOUS INJURY**.

⚠ WARNING

Indicates a hazardous situation which, if not avoided, **COULD** result in **DEATH** or **SERIOUS INJURY**.

⚠ CAUTION

Indicates a hazardous situation which, if not avoided, **COULD** result in **MINOR** or **MODERATE INJURY**.

NOTICE

Addresses practices not related to personal injury.









Potential hazards associated with the operation of this equipment will be referenced with hazard symbols which may appear throughout this manual in conjunction with safety messages.





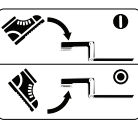

Symbol	Safety Hazard
	Lethal exhaust gas hazards
	Explosive fuel hazards
	Burn hazards
	Rotating parts hazards
	Pressurized fluid hazards

SAFETY INFORMATION

DECALS

Decals associated with the operation of this equipment are defined below.

DECAL	DEFINITION
	WARNING DO NOT Lift with Barrel/Pails NEVER attempt to lift the spray cart with chemicals loaded on the platform. ALWAYS unload the chemical platform before lifting the spray cart.
	WARNING Tipping Hazard Avoid slopes while operating.
	CAUTION Burn Hazard Hot parts can burn skin. DO NOT touch hot parts. Allow machine sufficient time to cool before performing maintenance.
	FUEL TYPE This engine requires unleaded gasoline.
	WARNING Secure Drum ALWAYS use the drum chain to secure a drum to the spray cart.
	WARNING Read Manual To avoid injury, you must read and understand the operator's manual before using this machine.
	WARNING DO NOT Tow on Street 10 mph maximum towing speed.
	WARNING Rotating Parts Hazard Keep hands and fingers clear from engine belts. Moving parts can cause injury. DO NOT remove guards.
	WARNING Guard Hazard DO NOT operate equipment with guards removed. Serious bodily injury may result.
	WARNING Engage Parking Brake ALWAYS set the parking brake when the unit is stationary.

DECAL	DEFINITION
	NOTICE Forklift Left Left forklift pocket.
	NOTICE Forklift Right Right forklift pocket.
	NOTICE Engage Compressor Left lever engages air compressor.
	NOTICE Engage Pump Right lever engages pump.
	NOTICE Lifting Location Attach a suitable lifting device here to lift the unit.
	
WARNING Fire, Smoking, Explosion, Inhalation Hazard DO NOT smoke or light matches near this equipment. This equipment contains highly flammable fuel. DO NOT use this equipment in an enclosed area.	

SAFETY INFORMATION

GENERAL SAFETY

CAUTION

- **NEVER** operate this equipment without proper protective clothing, shatterproof glasses, respiratory protection, hearing protection, steel-toed boots, and other protective devices required by the job or city and state regulations.



- Avoid wearing jewelry or loose-fitting clothes that may snag on the controls or moving parts, as this can cause serious injury.
- **NEVER** operate this equipment while on medication, or when not feeling well due to fatigue or illness. 
- **NEVER** operate this equipment under the influence of drugs or alcohol.



- **ALWAYS** clear the work area of any debris, tools, etc. that would constitute a hazard while the equipment is in operation.
- **ALWAYS** check the equipment for loose threads or bolts before starting.
- **DO NOT** use this equipment for any purpose other than its intended application.

NOTICE

- This equipment should **only** be operated by trained and qualified personnel 18 years of age or older.
- Replace nameplate, operation, and safety decals whenever they become difficult to read.
- Manufacturer does not assume responsibility for any accident due to equipment modifications. Unauthorized equipment modification will void all warranties.

- **NEVER** use accessories or attachments that are not recommended by Multiquip for this equipment. Damage to the equipment and/or injury to the user may result.

- **ALWAYS** know the location of the nearest **fire extinguisher**.



- **ALWAYS** know the location of the nearest **first aid kit**.



- **ALWAYS** know the location of the nearest phone, or **keep a phone on the job site**. Also, know the phone numbers of the nearest **ambulance, doctor, and fire department**. This information will be invaluable in case of an emergency.

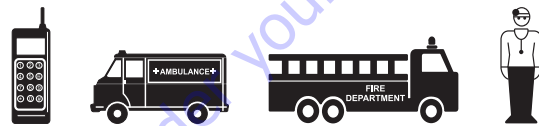

SPRAY CART SAFETY

DANGER

- **NEVER** operate this equipment in an explosive atmosphere or near combustible materials. An explosion or fire can result, causing **severe bodily harm or even death**. 
- **NEVER** disconnect any **emergency or safety devices**. These devices are intended for operator safety. Disconnection of these devices can cause **severe injury, bodily harm, or even death**. Disconnection of any of these devices will void all warranties.
- **NEVER** pump or spray **flammable** or **explosive** substances.
- **NEVER** use air from the spray cart's air compressor for respiration (breathing).

SAFETY INFORMATION

WARNING

- If the spray cart is operated indoors, discharge engine exhaust fumes **outdoors**.
- **NEVER** spray corrosive chemicals or water containing toxic substances. These fluids can create **serious health and environmental hazards**.
- **NEVER** engage in horseplay with hoses.
- **NEVER** blow compressed air directly at people. Scattered dust or foreign debris in the compressed air can cause **serious injury**.
- Blowing compressed air on food is **prohibited**.
- Residual air pressure can cause **severe bodily injury**.
- **NEVER** use the spray cart to pump or spray water or other liquids for human or animal consumption.
- **ALWAYS** relieve back pressure with the pump pressure regulator before disconnecting the spray gun or hoses.
- **ALWAYS** release all pressure within the system before servicing any components.
- **ALWAYS** drain all fluids from the spray system before servicing.

CAUTION

- **ALWAYS** be sure the operator is familiar with proper safety precautions and operating techniques before using the spray cart.
- **DO NOT** lubricate components or attempt service on a running machine.
- **DO NOT** operate the pump above recommended RPM.
- **DO NOT** operate the pump at pressures higher than the maximum recommended pressure for the pump.
- **DO NOT** block or restrict flow from the discharge hose. **ALWAYS** remove kinks from the discharge line before starting the pump. Operation with a blocked discharge line can cause water inside the pump to overheat.
- Keep personnel away from the discharge opening of hoses, tools or other points of compressed air.
- When blowing compressed air to remove dust and debris that has accumulated in such devices as air filters, **wear safety glasses, etc. to protect eyes**.

- **DO NOT** allow passengers or riders on the spray cart.
- **ALWAYS** engage the parking brake to prevent rolling while parked.

NOTICE

- **ALWAYS** keep the machine in proper running condition.
- Select tools, air hoses, pipes, valves, filters, and other fittings accordingly. **DO NOT** exceed the manufacturer's rated safe operating pressures for these items.
- Fix damage to the machine and replace any broken parts **immediately**.
- **ALWAYS** fill the pump housing with water before starting the engine. Failure to maintain water inside the pump housing will cause **severe damage to the pump and mechanical seal**.
- In winter, drain water from the pump housing to prevent freezing.
- **ALWAYS** store equipment properly when it is not being used. Equipment should be stored in a clean, dry location out of the reach of children and unauthorized personnel.

ENGINE SAFETY

DANGER

- Engine fuel exhaust gases contain poisonous carbon monoxide. This gas is colorless and odorless, and will cause **death** if inhaled.
- The engine of this equipment requires an adequate free flow of cooling air. **NEVER** operate this equipment in any enclosed or narrow area where free flow of the air is restricted. If the air flow is restricted, it will cause **injury to people and property, and serious damage to the equipment or engine**.



SAFETY INFORMATION

WARNING

- **NEVER** place hands or fingers inside the engine compartment while the engine is running.
- **NEVER** operate the engine with heat shields or guards removed.
- To prevent injury, keep fingers, hands, hair, and clothing away from all moving parts. 
- **NEVER** remove the engine oil drain bolt while the engine is **hot**. Hot oil will gush out of the oil tank and severely scald any persons in the area of the spray cart.

CAUTION

- **DO NOT** leave the engine running while the spray cart is unattended. **ALWAYS** turn off the engine when unattended. 
- **DO NOT** touch the hot exhaust manifold, muffler, or cylinder. Allow these parts to cool before servicing the equipment.
- **DO NOT** crank a flooded engine with the spark plug removed. Fuel trapped in the cylinder may squirt out of the spark plug opening.

NOTICE

- **DO NOT** run the engine without an air filter, or with a dirty air filter. **Severe engine damage may occur.** Service the air filter frequently to prevent engine malfunction.
- **DO NOT** tamper with the factory settings of the engine or engine governor. **Damage to the engine or equipment can result** if operating in speed ranges above the maximum allowable. 

FUEL SAFETY

DANGER

- **NEVER** start the engine near spilled fuel or combustible fluids. Fuel is extremely flammable and its vapors can cause an **explosion** if ignited.
- **ALWAYS** refuel in a well-ventilated area, away from sparks and open flames.

- **ALWAYS** use extreme caution when working with flammable liquids.
- **NEVER** fill the fuel tank while the engine is running or hot.
- **NEVER** overfill the fuel tank, since spilled fuel can **ignite** if it comes into contact with hot engine parts or sparks from the ignition system.
- Store fuel in appropriate containers, in well-ventilated areas, away from sparks and flames.
- **NEVER** use fuel as a cleaning agent.
- **NEVER** smoke around or near the equipment. **Fire or explosion** can result from fuel vapors. 

TRANSPORTING SAFETY

WARNING

- **NEVER** attempt to lift the spray cart with chemicals loaded on the platform. **ALWAYS** unload the chemical platform before lifting the spray cart. Disconnect and stow all hoses before lifting.
- When lifting the spray cart, make sure the rated lifting capacity of the lifting equipment meets or exceeds the weight of the spray cart. Make sure forklift forks are at least 2/3 the length of the spray cart.
- The spray cart is heavy and awkward to move around. **NEVER** attempt to lift the unit alone. **ALWAYS** use proper heavy lifting procedures.
- **BE CAREFUL** when lifting the spray cart. A dropped spray cart can cause **serious personal injury** and damage to the equipment. **NEVER** lift the spray cart to unnecessary heights. **NEVER** stand underneath the spray cart while it is being lifted.

NOTICE

- **DO NOT** transport the equipment while the engine is running. **ALWAYS** shut down the engine before transporting.
- Tighten the fuel tank cap securely and close the fuel valve lever while transporting the equipment to prevent fuel from spilling.
- **ALWAYS** tie down equipment securely with rope during transport.

SAFETY INFORMATION

TOWING SAFETY

CAUTION

- **DO NOT** tow the spray cart on public roads. The tow hitch is for **on-site towing only**.
- Recommended off-road towing is not to exceed **15 MPH** or less, depending on the type of terrain.
- **DO NOT** tow the spray cart with defective hitches, couplings, chains, etc. **ALWAYS** inspect the hitch and coupling for wear.
- Avoid sudden starts and stops, which can cause **skidding or jackknifing**. Smooth, gradual starts and stops will improve towing.
- Avoid sharp turns to prevent rolling.
- Disconnect and stow hoses while towing.

ENVIRONMENTAL SAFETY/DECOMMISSIONING

NOTICE

Decommissioning is a controlled process used to safely retire a piece of equipment that is no longer serviceable. If the equipment poses an unacceptable and unreparable safety risk due to wear or damage, or is no longer cost effective to maintain (beyond life-cycle reliability), and is to be decommissioned (demolition and dismantlement), follow the guidelines below.

- **NEVER** pour waste or oil directly onto the ground, down a drain, or into any water source.
- Contact your country's Department of Public Works or the recycling agency in your area and arrange for proper disposal of any electrical components, waste, or oil associated with this equipment. 
- When the life cycle of this equipment is over, it is recommended that the frame and all other metal parts be sent to a recycling center.

Metal recycling involves the collection of metal from discarded products and its transformation into raw materials to use in manufacturing a new product.

Recyclers and manufacturers alike promote the process of recycling metal. Using a metal recycling center promotes energy cost savings.

EMISSIONS INFORMATION

NOTICE

The gasoline engine used in this equipment has been designed to reduce harmful levels of carbon monoxide (CO), hydrocarbons (HC) and nitrogen oxides (NOx) contained in gasoline exhaust emissions.

In the installed configuration, this engine has been certified to meet US EPA evaporative emissions requirements.

Attempting to modify or make adjustments to the engine emission system by unauthorized personnel without proper training could damage the equipment or create an unsafe condition.

Additionally, modifying the fuel system may adversely affect evaporative emissions, resulting in fines or other penalties.

Emission Control Label

The emission control label is an integral part of the emission system and is strictly regulated.

The label must remain with the engine for its entire life.

If a replacement emission label is needed, please contact your authorized engine distributor.

LIFTING AND TRANSPORTING

WARNING

MAKE SURE the rated lifting capacity of the lifting equipment meets or exceeds the weight of the spray cart. **MAKE SURE** forklift forks are at least 2/3 the length of the spray cart. See Table 1 and Table 4 for spray cart specifications and dimensions.

WARNING

The spray cart is heavy and awkward to move around. **NEVER** attempt to lift the unit alone. **ALWAYS** use proper heavy lifting procedures.

WARNING

NEVER attempt to lift the spray cart with chemicals loaded on the platform. **ALWAYS** unload the chemical platform before lifting the spray cart. Disconnect and stow all hoses before lifting.

WARNING

BE CAREFUL when lifting the spray cart. A dropped spray cart can cause serious personal injury and damage to the equipment. **NEVER** lift the spray cart to unnecessary heights. **NEVER** stand underneath the spray cart while it is being lifted.

LIFTING THE SPRAY CART

Using a crane or forklift to lift the spray cart is **highly recommended**. **ALWAYS** use extra care when lifting the spray cart off the ground.

There are two different ways to lift the spray cart for transport—the crane hook or the forklift pockets.

Crane Hook

The crane hook provides an optimal lift point for the spray cart. To lift the unit, attach a chain or rope to the crane hook (Figure 1).

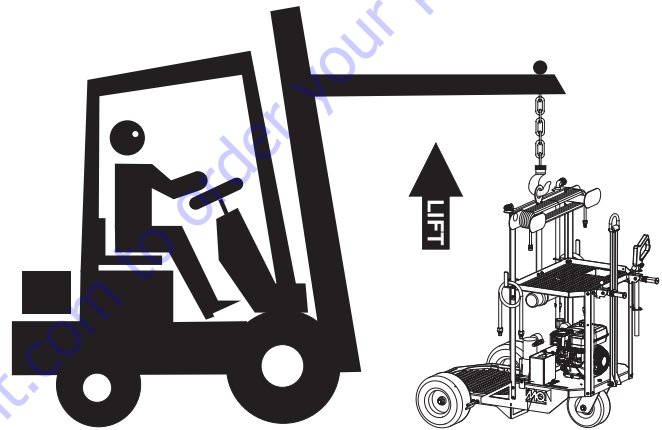

Figure 1. Crane Hook

Forklift Pockets

To lift the spray cart using the forklift pockets, fully insert the forklift forks through the spray cart's forklift pockets as shown in Figure 2.

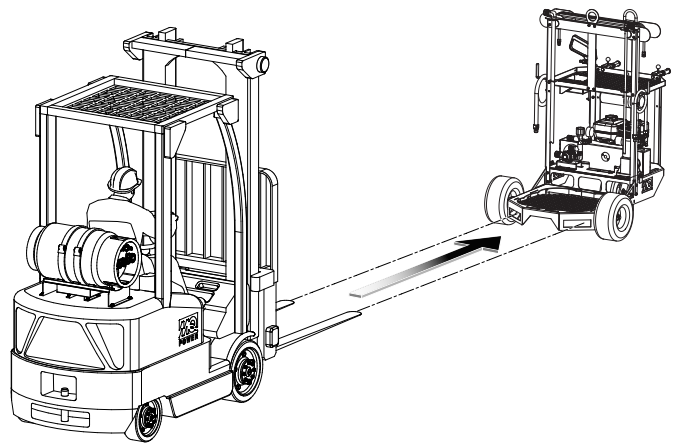

Figure 2. Forklift Pockets

SPECIFICATIONS

Table 1. Spray Cart Specifications

Model	WSC55	WSC55BM	WSC55C
Weight — lb. (kg)	290 (131)	82 (37)	208 (94)
Flow Rate — gpm (liters/min)	9 (34.1)	9 (34.1)	N/A
Max. Pressure — lb/in ² (kPa)	150 (1034)	150 (1034)	N/A
Hose Length — ft. (m)	50 (15.2)	50 (15.2)	N/A
Pump Type	Roller	Roller	N/A

Table 2. Engine Specifications

Model	Honda GX160
Type	Air-cooled, 4-stroke, single-cylinder OHV
Displacement	9.95 in ³ (163 cm ³)
Bore x Stroke	2.68 in. x 1.77 in. (68 mm x 45 mm)
Max. Output	4.8 hp (3.6 kW) @ 3600 rpm
Max. Torque	7.6 ft-lbf (10.3 N·m) @ 2500 rpm
Engine Oil Type	4-stroke API, SF or SG SAE 10W-30 general use
Engine Oil Capacity	0.61 qt. (0.58 liters)
Lubricating System	Splash
Fuel Type	Unleaded 86 octane or higher
Fuel Tank Capacity	0.825 gallons (3.1 liters)
Starting System	Recoil start
Dimensions (L x W x H)	12.2 in. x 14.3 in. x 13.6 in. (312 mm x 362 mm x 346 mm)
Weight	33 lb. (15.1 kg)

Table 3. Compressor Specifications

Model	Schulz MSI 5,2 ML
Type	Single-stage, low pressure
Motor	1 hp (0.75 kW)
Displacement	5.2 ft ³ /min (0.15 m ³ /min)
Max. Pressure	120 lb/in ² (861.8 kPa)
Oil Capacity	0.094 qt. (0.09 liters)
Cylinder Diameter	2 in. (50.8 mm)
Stroke	1.259 in. (32 mm)
RPM	2275
Weight	13 lb. (5.9 kg)
Flywheel Size	6.3 in. (160 mm)

DIMENSIONS

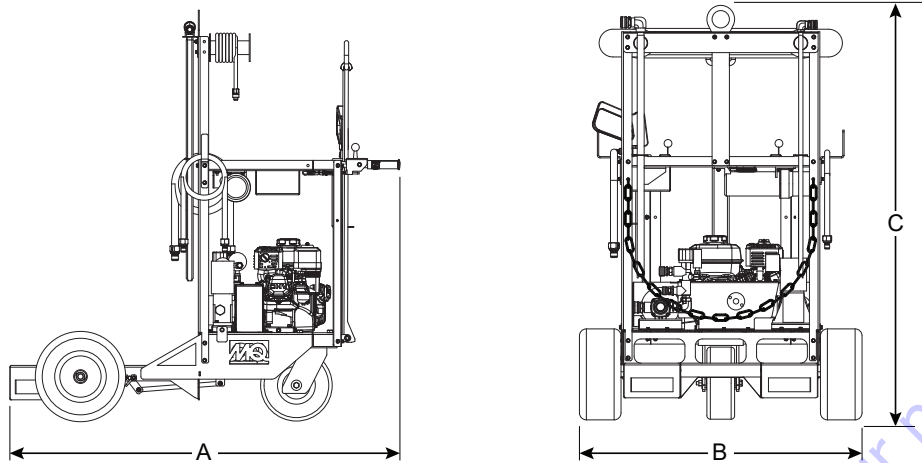

Figure 3. WSC55 Spray Cart Dimensions

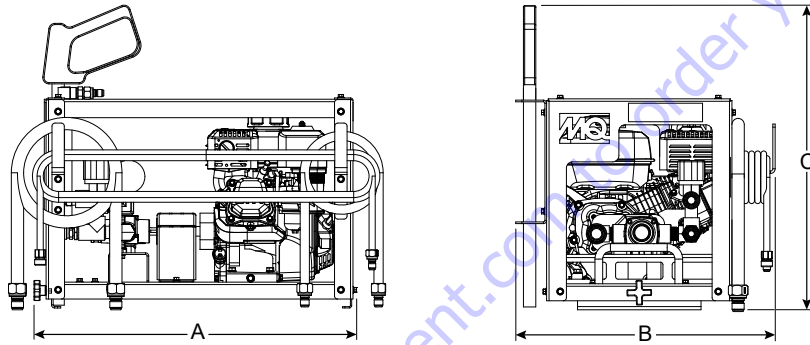

Figure 4. WSC55BM (Barrel Mount) Dimensions

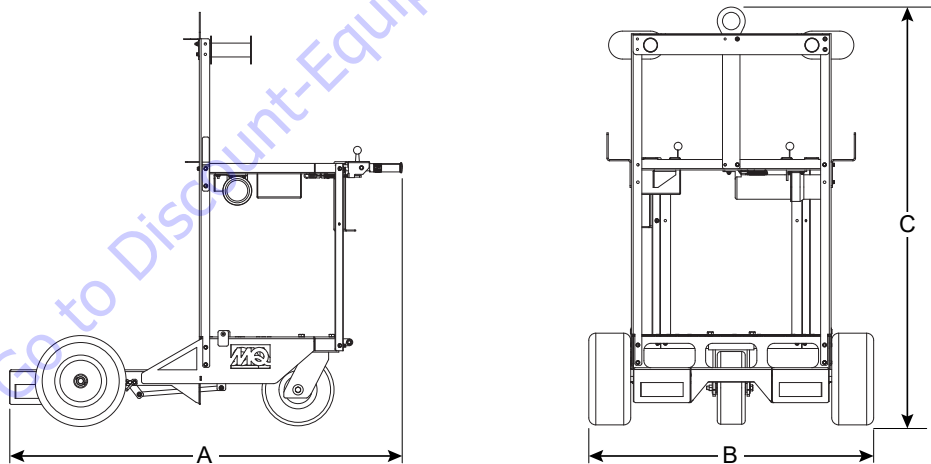

Figure 5. WSC55C (Cart Only) Dimensions

Table 4. Dimensions

Model	WSC55	WSC55BM	WSC55C
(A) Length — in. (cm)	56 (142.2)	26 (66.0)	56 (142.2)
(B) Width — in. (cm)	41 (104.1)	21 (53.3)	41 (104.1)
(C) Height — in. (cm)	60 (152.4)	24 (61.0)	56 (142.2)

NOISE AND VIBRATION EMISSIONS

Table 5. Noise and Vibration Emissions

Model	WSC55	WSC55BM
Guaranteed ISO 11201:2010 Based Sound Pressure Level at Operator Station in dB(A)	TBD	TBD
Guaranteed ISO 3744:2010 Based Sound Power Level in dB(A)	~115	TBD
Whole Body Vibration per ISO 2631-1:1997+A1:2010 in $m/s^2 \Sigma A(8)$	N/A	N/A

NOTES:

1. Sound pressure and power levels are "A" weighted measures per ISO 226:2003 (ANSI S1.4-1981). They are measured with the operating condition of the machine which generates the most repeatable but highest values of the sound levels. Under normal circumstances, the sound level will vary depending on the condition of the material being worked upon.
2. The vibration level indicated is the vector sum of the RMS (root mean square) values of amplitudes on each axis, standardized to an 8-hour exposure period, and obtained using operating conditions of the machine that generate the most repeatable but highest values in accordance with the applicable standards for the machine.
3. Per EU Directive 2002/44/EC, the daily exposure action value for hand-arm vibration is $2.5 m/s^2 \Sigma A(8)$. The daily exposure limit value is $5.0 m/s^2 \Sigma A(8)$.

Go to Discount-Equipment.com to order your parts

GENERAL INFORMATION

INTENDED USE

Operate this equipment only in accordance with the manufacturer's instructions. Any deviation from the manufacturer's intended use is strongly discouraged, and the risk of such use remains entirely with the user. The manufacturer cannot be held liable for damages incurred as a result of misuse.

FAMILIARIZATION

Safety instructions are found on the spray cart and throughout this manual. **Read all safety instructions carefully.** Maintain all safety information in readable condition. Operators should be well-trained on operation and maintenance of the unit.

The WSC55 chemical spray cart is designed for the easy dispersion of liquid chemicals in a variety of construction and maintenance applications. The chemical platform holds one 55-gallon (208-liter) drum (not included) or up to four 5-gallon (18.9-liter) buckets (not included). The platform's sloped design allows all material inside the drum or buckets to enter the suction tube, eliminating the waste of costly chemical products.

Walk around the spray cart and observe each of the major components (Figure 6)—engine, compressor, pump, hoses, spray gun, etc. Familiarize yourself with each component and its function before operating the unit.

Engine

The WSC55 chemical spray system is powered by a Honda GX160 air-cooled, 4-stroke, 4.8-hp, gasoline engine (Figure 10). For basic engine maintenance, refer to the **Maintenance** section of this manual. For more detailed engine maintenance, refer to the Honda engine owner's manual.

Compressor

An engine-driven, onboard air compressor is provided for clearing any remaining liquid from the spray system after use. Unused liquid remaining in the hoses can be cycled back into the drum or buckets, reducing waste and maintenance. Refer to the **Specifications**, **Components (Compressor)**, and **Operation** sections of this manual for more information about the compressor.

Pump and Hoses

A cast-iron, four-roller pump delivers liquid to the spray assembly from the user-supplied drum or buckets. The pump is equipped with permanently lubricated bearings that do not require further lubrication.

A 50-foot (15-meter) hose is provided with the spray cart. However, the hose wrap will accommodate a 3/8-inch hose up to 300 feet (91 meters) long. The spray gun, tubes, and hoses are all equipped with quick-connect fittings for fast and easy coupling.

Control Levers

Dual control levers are provided for operation of the pump and compressor. The right lever engages the pump, and the left lever engages the compressor. Refer to the **Operation** section of this manual for more information.

Maneuverability

A single rear wheel and gripped control handles provide easy steering and maneuverability of the spray cart, and a parking brake secures the unit on unstable or uneven ground. Forklift pockets and a crane hook are provided for lifting the unit, and a tow hitch allows easy transportation of the unit around the jobsite.

Options

The chemical spray system is available as a stationary barrel mount option (Model WSC55BM). A compressor is not provided with the barrel mount. Refer to the **Options** and **Components (Barrel Mount)** sections of this manual for more information on the barrel mount. A cart-only option is also available (Model WSC55C). Refer to the part numbers below when ordering either of these units.

MODEL	P/N	Description
WSC55BM	49202	BARREL MOUNT
WSC55C	49203	CART ONLY

TRAINING

For proper training, please use the **Training Checklist** form located in the front of this manual. This checklist is an outline for an experienced operator to provide training to a new operator.

COMPONENTS (SPRAY CART)

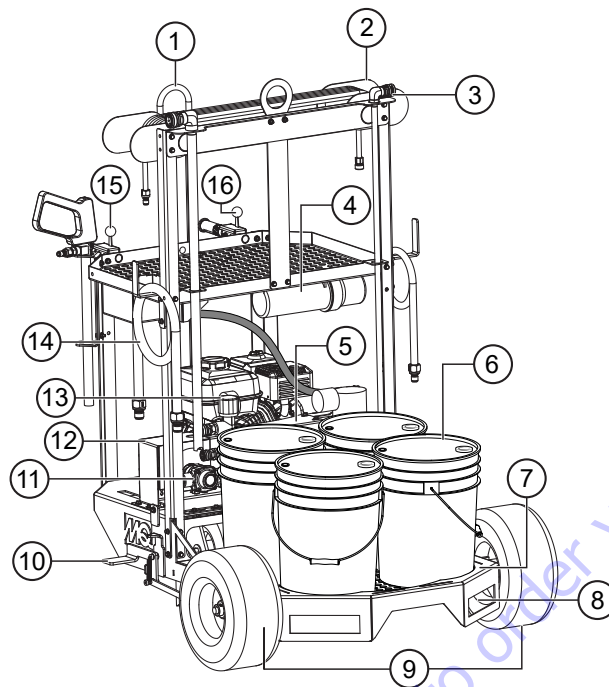

Figure 6. WSC55 Spray Cart Components (Front)

Figure 6 and Figure 7 show the location of the spray cart's basic components. Listed below is a brief explanation of each component.

1. **Tow Hitch** — Allows the spray cart to be transported easily around the jobsite.

WARNING

NEVER tow the spray cart on surface streets. The tow hitch is for **on-site towing only**.

2. **Hose Wrap** — Will hold a 3/8-inch hose up to 300 feet (91 meters) long.
3. **Return Tube** — Returns unused liquid to the supply container(s). A quick-connect fitting provides easy coupling with the return hose.
4. **Manual Holder** — Provides storage for manuals and any other documentation relating to the spray cart.
5. **Belt Guard** — Houses the drive belt.
6. **5-Gallon (18.9-Liter) Buckets (4)** — Customer-provided.
7. **Chemical Platform** — Holds one 55-gallon (208-liter) drum or up to four 5-gallon (18.9-liter) buckets. Sloped design eliminates waste.
8. **Forklift Pockets (2)** — To lift the unit, insert forklift forks here.
9. **Front Wheels** — Treadless tires reduce the risk of floor damage.
10. **Parking Brake** — Secures the unit on unstable or uneven ground.
11. **Pump** — Delivers liquid to the spray assembly from the supply container(s). Quick-connect fittings provide easy coupling with the hoses.
12. **Clutch Guard (Pump)** — Houses the pump clutch.
13. **Pressure Regulator** — Adjusts pump/spray pressure.
14. **Suction Hose** — Connects the suction tube to the pump. Quick-connect fittings provide easy coupling.
15. **Pump Control Lever** — Engages the pump. Push forward to increase spray pressure, and pull backward to decrease spray pressure.
16. **Compressor Control Lever** — Engages the air compressor. Push forward to increase air pressure, and pull backward to decrease air pressure.

COMPONENTS (SPRAY CART)

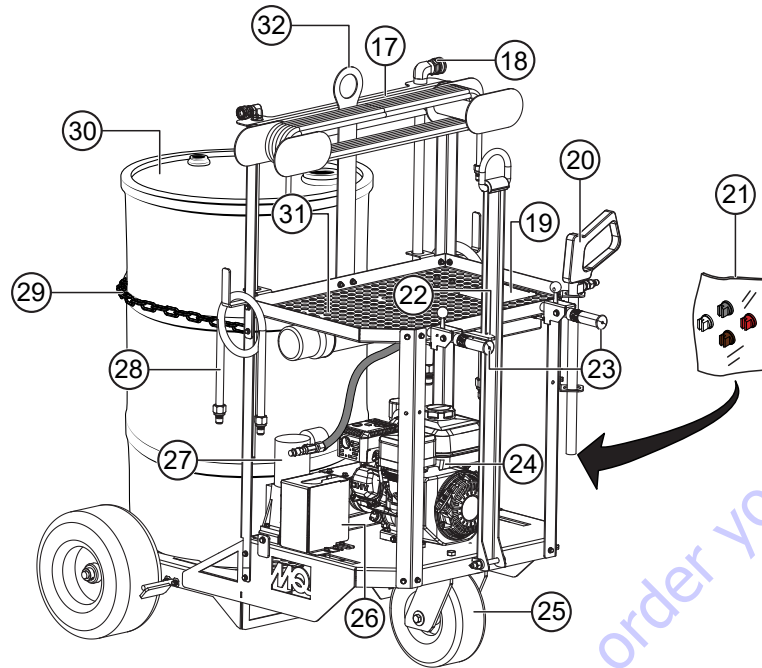

Figure 7. WSC55 Spray Cart Components (Rear)

17. **Main Hose** — A 50-foot (15-meter) hose with quick-connect fittings for easy coupling with the pump and spray gun.
18. **Suction Tube** — Delivers liquid from the supply container(s) to the spray assembly. A quick-connect fitting provides easy coupling with the suction hose.
19. **Spray Tip Bin** — Store spray tips or other small items here for easy access.
20. **Spray Gun** — Disperses liquids onto their final application. A quick-connect fitting provides easy coupling with the main hose.
21. **Spray Tips** — Attach to the spray gun to provide options for different spray applications.
22. **Hitch Latch** — Secures the tow hitch.
23. **Steering Control Handles** — Gripped control handles provide comfort for the operator while steering.
24. **Engine** — A Honda GX160 air-cooled, 4-stroke, 4.8-hp, gasoline engine. See the **Components (Engine)** section for more information.
25. **Rear Wheel** — A single caster wheel provides easy steering of the unit.
26. **Clutch Guard (Compressor)** — Houses the compressor clutch.
27. **Compressor** — An engine-driven air compressor used for clearing any liquid remaining in the spray system after use. A quick-connect fitting provides easy coupling with the hoses.
28. **Return Hose** — Connects the pump to the return tube. Quick-connect fittings provide easy coupling.
29. **Drum Chain** — Secures a 55-gallon (208-liter) drum to the chemical platform.
30. **55-Gallon (208-Liter) Drum** — Customer-provided.
31. **Tool Tray** — Holds tools and other materials.
32. **Crane Hook** — To lift the unit, attach a suitable lifting device here.

COMPONENTS (BARREL MOUNT)

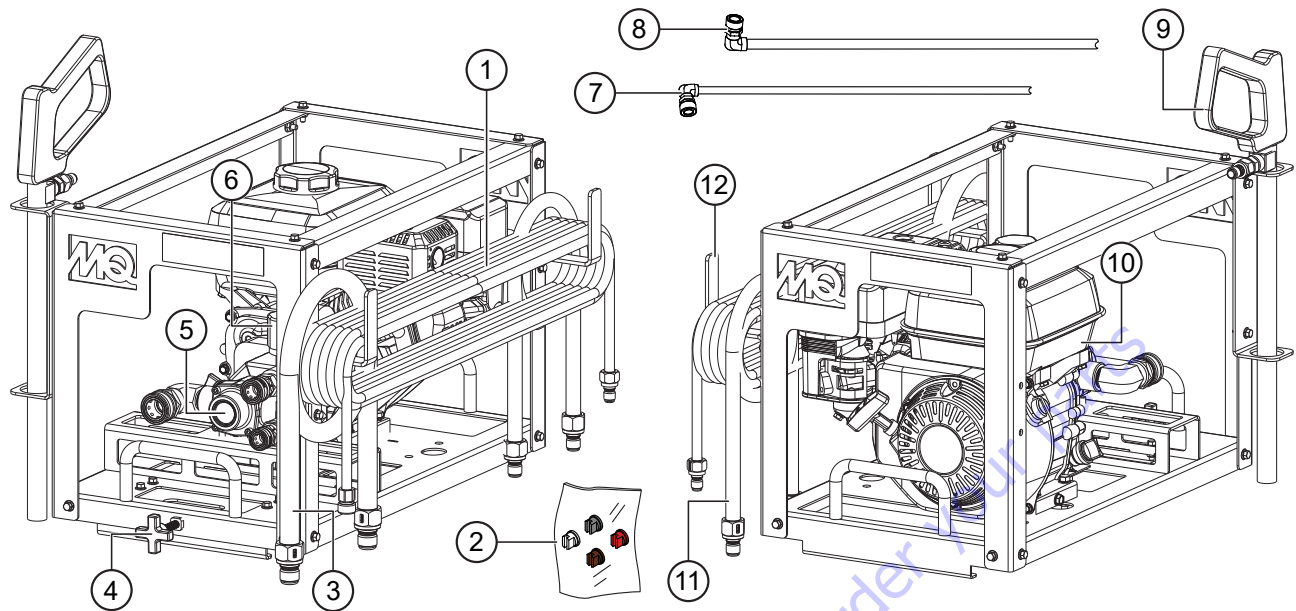

Figure 8. WSC55BM Barrel Mount Components

The chemical spray system is available as a barrel mount attachment (Model WSC55BM), providing the user with a stationary option. A compressor is not provided with the barrel mount. Figure 8 shows the location of the barrel mount's basic components. Listed below is a brief explanation of each component.

1. **Main Hose** — A 50-foot (15-meter) hose with quick-connect fittings for easy coupling with the pump and spray gun.
2. **Spray Tips** — Attach to the spray gun to provide options for different spray applications. See Table 8 for spray tip selection information
3. **Suction Hose** — Connects the suction tube to the pump. Quick-connect fittings provide easy coupling.
4. **Thumb Screw** — Turn **clockwise** to secure the barrel mount to a drum.
5. **Pump** — Delivers liquid to the spray assembly from the supply container(s). Quick-connect fittings provide easy coupling with the hoses.
6. **Pressure Regulator** — Adjusts pump/spray pressure.
7. **Return Tube** — The smaller of the two tubes returns unused liquid to the supply container(s). A quick-connect fitting provides easy coupling with the return hose.
8. **Suction Tube** — The larger of the two tubes delivers liquid from the supply container(s) to the spray assembly. A quick-connect fitting provides easy coupling with the suction hose.
9. **Spray Gun** — Disperses liquids onto their final application. A quick-connect fitting provides easy coupling with the main hose.
10. **Engine** — A Honda GX160 air-cooled, 4-stroke, 4.8-hp, gasoline engine. See the **Components (Engine)** section for more information.
11. **Return Hose** — Delivers liquid from the pump to the return tube. Quick-connect fittings provide easy coupling.
12. **Hose Wrap** — Will hold a 3/8-inch hose up to 300 feet (91 meters) long.

COMPONENTS (COMPRESSOR)

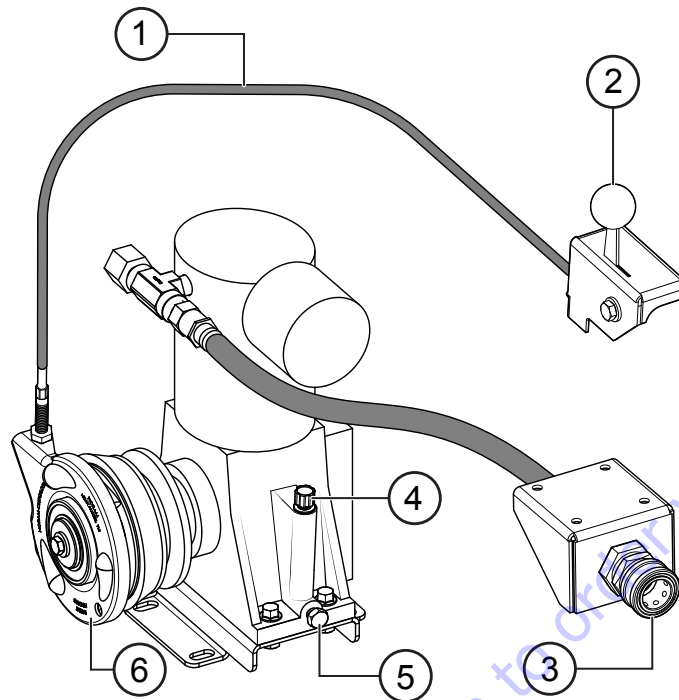

Figure 9. Compressor Components

An engine-driven, onboard air compressor is provided for clearing liquid from the spray system after use. Figure 9 shows the location of the compressor's basic components. Listed below is a brief explanation of each component.

1. **Clutch Cable** — Connects the compressor control lever to the compressor. Attaches to the compressor clutch.
2. **Compressor Control Lever** — Mounted on the left handlebar. Engages the air compressor. Push forward to engage the compressor, and pull backward to disengage the compressor.
3. **Compressor Port** — Attach the main hose here to clear liquid from the spray assembly. See the **Operation** section for more information.
4. **Dipstick/Oil Filler Cap** — Remove to determine if compressor oil is low. Add oil through this port as recommended in Table 7.
5. **Oil Drain Bolt** — Remove to drain oil from the compressor crankcase.
6. **Clutch** — Attaches to the clutch cable to provide compressor control.

COMPONENTS (ENGINE)

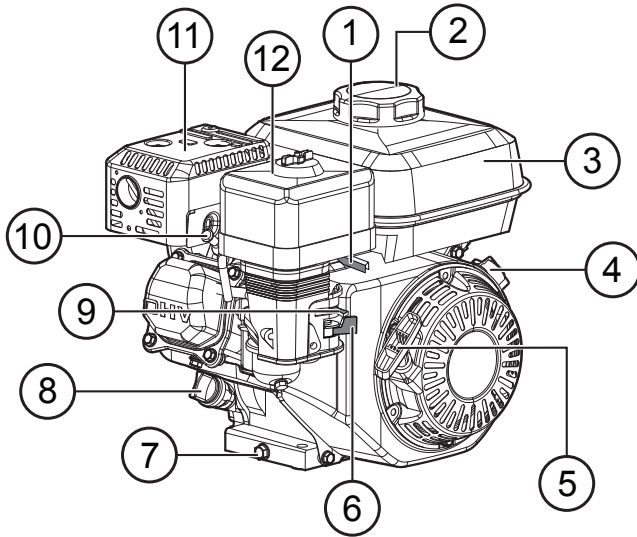

Figure 10. Honda GX160 Engine Components

The Honda GX160 engine (Figure 10) must be checked for proper lubrication and filled with fuel prior to operation. Refer to the manufacturer's engine manual for detailed operation and service instructions.

1. **Throttle Lever** — Adjusts engine RPM speed.
2. **Fuel Filler Cap** — Remove to add unleaded gasoline to the fuel tank. Make sure cap is tightened securely. **DO NOT** overfill.

! DANGER



NEVER fill the fuel tank while the engine is running or hot. In the event of a fuel spill, **DO NOT** start the engine until all fuel residue has been wiped up and the area surrounding the engine is dry. Fuel is **extremely flammable** and can ignite if it comes into contact with hot engine parts or sparks from the ignition system.

3. **Fuel Tank** — Holds up to 0.825 gallons (3.1 liters) of unleaded gasoline. Refer to the manufacturer's engine manual for additional information.
4. **Engine ON/OFF Switch** — **ON** position permits engine starting, **OFF** position stops engine operation.

! CAUTION

DO NOT disable or disconnect the engine **ON/OFF** switch. It is provided for operator safety. Injury may result if it is disabled, disconnected, or improperly maintained.

5. **Recoil Starter** — Manual starting mechanism. Slowly pull the starter grip until resistance is felt, then pull briskly and smoothly to start the engine.
6. **Fuel Valve Lever** — Open to allow the flow of fuel, and close to prevent the flow of fuel.
7. **Oil Drain Bolt** — Remove to drain oil from the engine crankcase.
8. **Dipstick/Oil Filler Cap** — Remove to determine if engine oil is low. Add oil through this port as recommended in Table 6.
9. **Choke Lever** — Aids in starting a cold engine, or starting in cold weather conditions. The choke enriches the fuel mixture.
10. **Spark Plug** — Provides spark to the ignition system. Set the spark plug gap according to the engine manufacturer's instructions, and clean the spark plug once a week.
11. **Muffler** — Reduces noise and emissions. **NEVER** touch the muffler while it is hot.

! WARNING



Engine components can generate extreme heat. To prevent burns, **NEVER** touch these areas while the engine is running or immediately after operating. **NEVER** operate the engine with the muffler removed.

12. **Air Cleaner** — Prevents dirt and other debris from entering the fuel system. Remove the wing nut on top of the air cleaner to gain access to the filter elements.

NOTICE

Operating the engine without an air filter, or with a damaged or worn air filter in need of replacement, will allow dirt to enter the engine, causing rapid engine wear.

INITIAL ASSEMBLY

Some assembly is required before the WSC55 can be operated.

Refer to the **WSC55 Initial Assembly Instructions (P/N 49274)** shipped with the unit.

Once the initial assembly is complete, proceed with the following set-up instructions.

SUPPLY PREPARATION

Perform the following procedure to load the chemical platform for use.

1. Engage the parking brake to secure the spray cart in place (Figure 11).

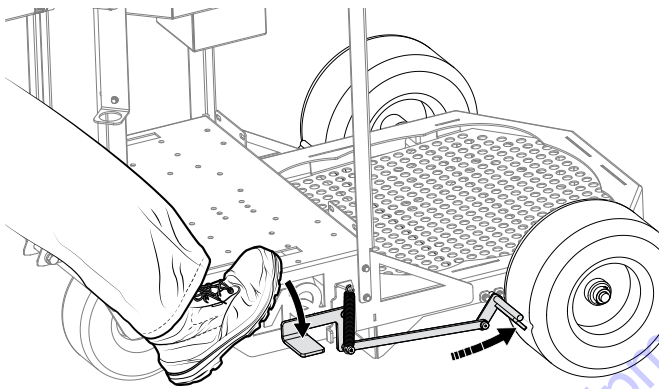

Figure 11. Engage Parking Brake

2. Carefully load your liquid chemical supply onto the chemical platform. The platform will hold up to four 5-gallon (18.9-liter) buckets (Figure 12) or one 55-gallon (208-liter) drum (Figure 13).

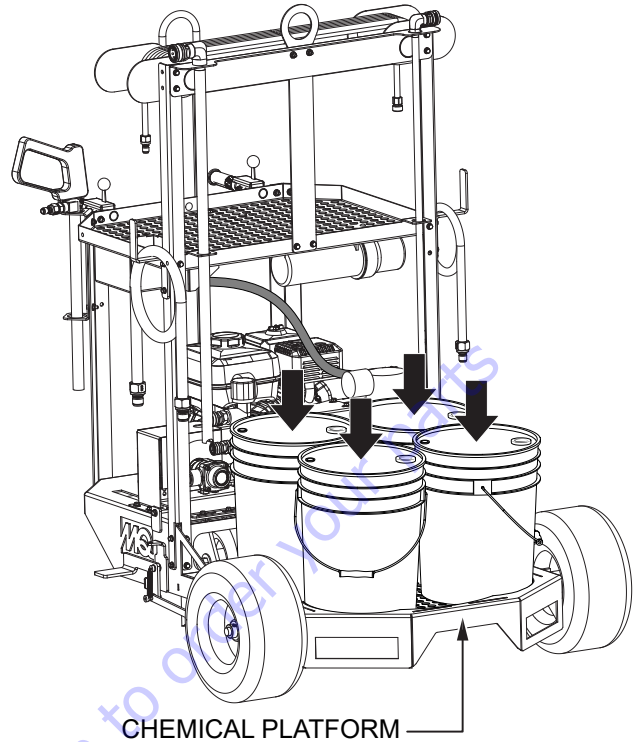

Figure 12. Loaded Chemical Platform (Buckets)

3. If loading a 55-gallon drum, use a drum lifter or drum grabber forklift attachment to load the drum onto the platform. Secure the drum to the platform with the drum chain as shown in Figure 13.

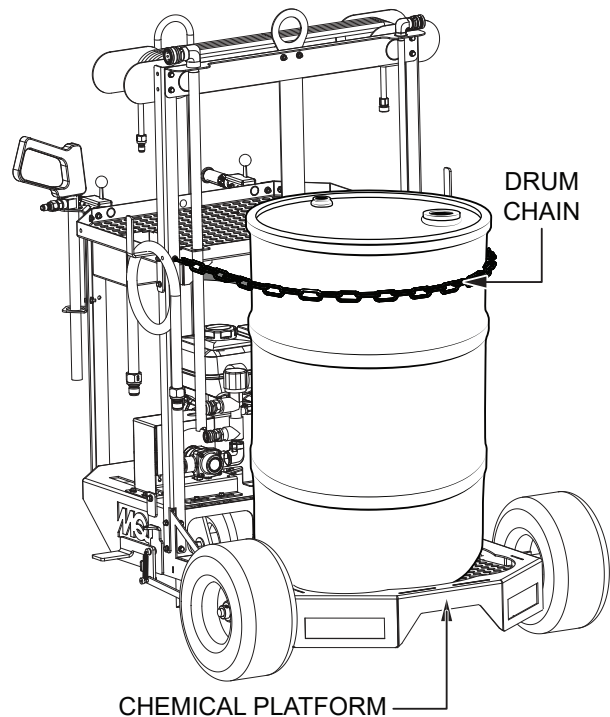

Figure 13. Loaded Chemical Platform (Drum)

4. Locate the bung holes on top of the supply container(s). Break the bung hole cap seals (if necessary) and unscrew the bungs (plugs) to remove. See Figure 14.

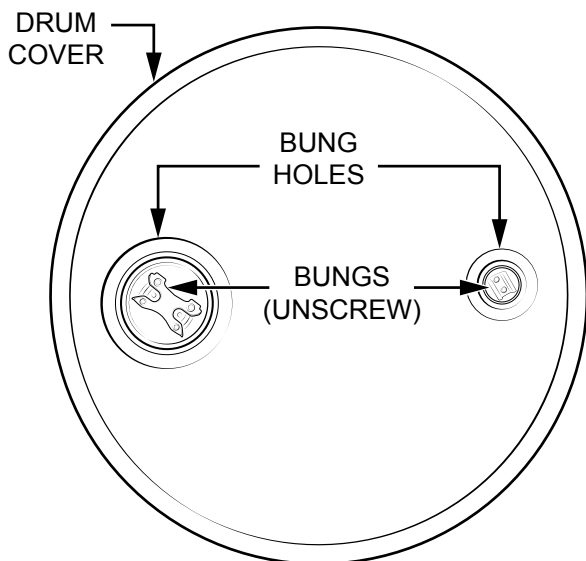

Figure 14. Open Supply Container

5. Insert the **suction** tube (the **larger** of the two tubes) into the top of the supply container(s). If the bung holes are different sizes, be sure to place the suction tube into the **larger** hole. See Figure 15.

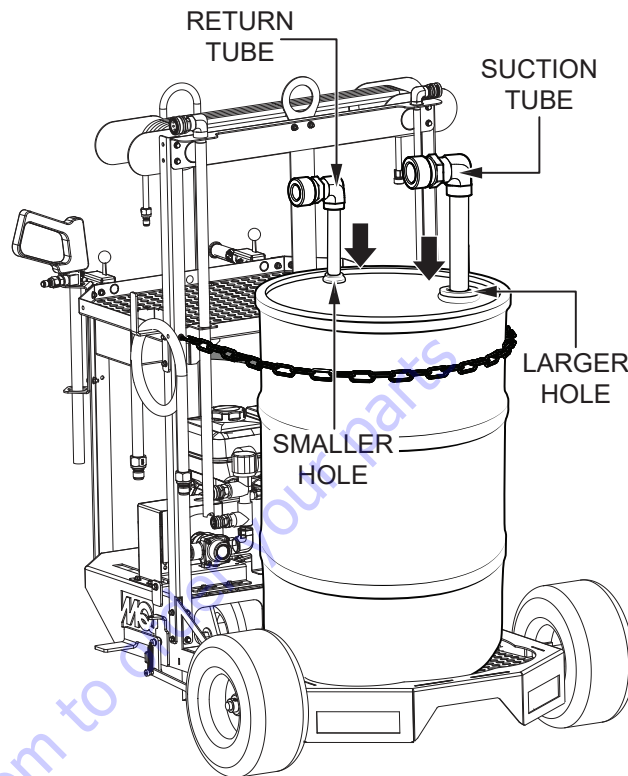

Figure 15. Tube Installation

6. Insert the **return** tube (the **smaller** of the two tubes) into the top of the supply container(s). If the bung holes are different sizes, be sure to place the return tube into the **smaller** hole (Figure 15).

Go to Discount-Equipment.com to purchase your parts

SPRAY SYSTEM ASSEMBLY

Perform the following procedure to assemble the spray system for use. Refer to Figure 16.

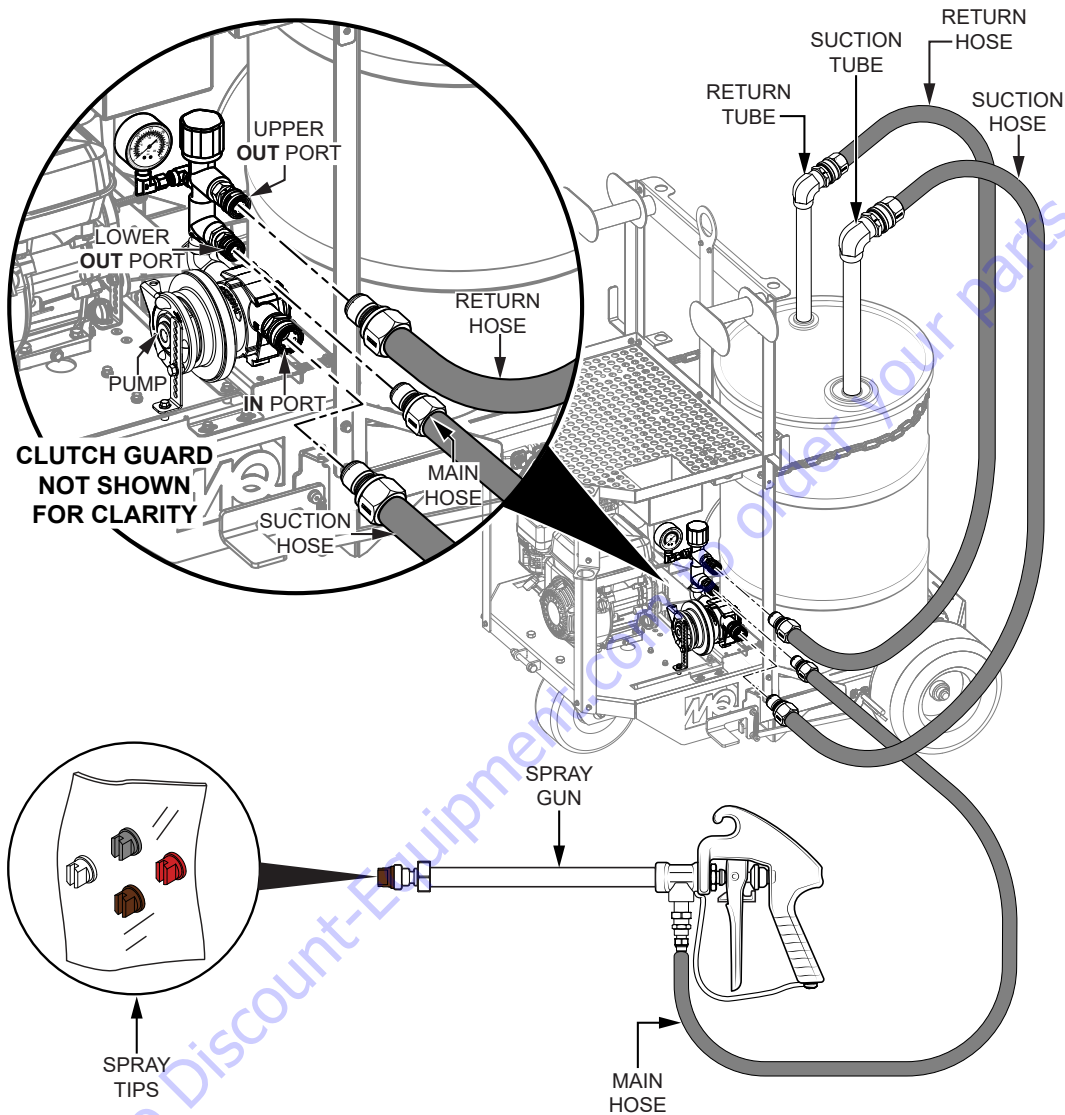

Figure 16. Spray System Assembly

1. Connect one end of the suction hose to the **IN** port on the pump.
2. Connect the other end of the suction hose to the suction tube.
3. Connect one end of the return hose to the upper **OUT** port on the pump.
4. Connect the other end of the return hose to the return tube.
5. Connect the male fitting on one end of the main hose to the lower **OUT** port on the pump.
6. Connect the female fitting on the other end of the main hose to the male fitting on the spray gun.
7. Choose an appropriate spray tip for the desired application, and install it onto the end of the spray gun. Always refer to the chemical manufacturer's recommendations when selecting a spray tip. Refer to Table 8 for spray tip selection information.
8. Make sure all spray system connections are secure.

BEFORE STARTING

1. Read all safety instructions at the beginning of this manual.
2. Clean the unit, particularly the engine cooling air inlet. Remove dirt and dust.
3. Inspect the air cleaner, and replace it with a new one if dirty or dusty.
4. Check the carburetor for external dirt and dust. Clean with dry compressed air.
5. Check fastening nuts and bolts for tightness.

CAUTION



ALWAYS wear appropriate personal protective equipment while operating this equipment.

CAUTION



DO NOT place hands or feet inside the belt guard while the engine is running. **ALWAYS** shut down the engine before performing any service on this equipment.

ENGINE OIL

1. Place the unit on secure, level ground with the engine turned off.
2. Remove the engine oil dipstick (Figure 17) and wipe it clean.

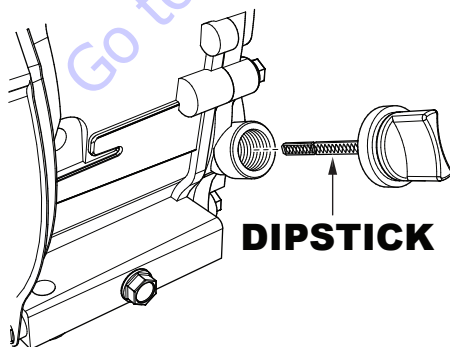

Figure 17. Engine Oil Dipstick Removal

3. Reinsert the dipstick, then remove the dipstick without screwing it in.
4. Check the oil level shown on the dipstick (Figure 18). If the oil level is low, fill to the edge of the oil filler hole with the recommended oil type (Table 6). Maximum oil capacity is 0.61 quarts (0.58 liters).

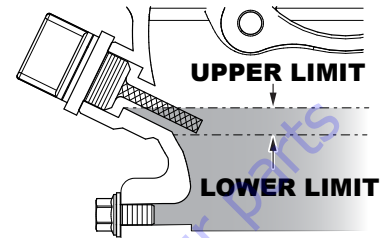

Figure 18. Checking Engine Oil

Table 6. Engine Oil Type

Season	Temperature	Oil Type
Summer	25°C or Higher	SAE 10W-30
Spring/Fall	25°C ~ 10°C	SAE 10W-30/20
Winter	0°C or Lower	SAE 10W-10

FUEL

DANGER



Motor fuels are **highly flammable** and can be dangerous if mishandled. **NEVER** smoke while refueling. **NEVER** attempt to refuel while the engine is **hot** or **running**.

1. Remove the fuel filler cap located on top of the fuel tank.
2. Visually inspect the fuel level. If fuel is low, fill the tank with unleaded gasoline. Use a strainer for filtration while refueling.

DANGER

NEVER top off fuel. Wipe up any spilled fuel immediately.

SPRAY SYSTEM

1. Inspect the pump inlet (**IN**) and discharge (**OUT**) lines to make sure they are clear. Obstructed lines will prevent self-priming of the pump. See Figure 19.

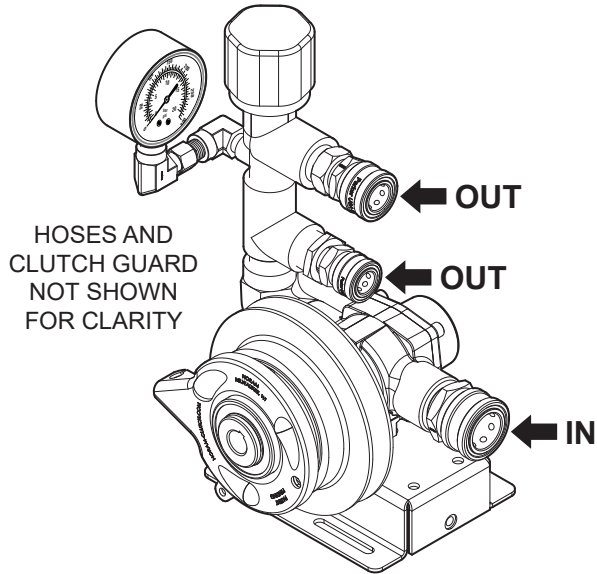

Figure 19. Pump Inspection

2. Inspect all hoses for weak or worn condition, and replace as necessary.
3. Inspect the O-rings inside each of the quick-connect fittings for damage or wear (Figure 20). Replace if necessary.

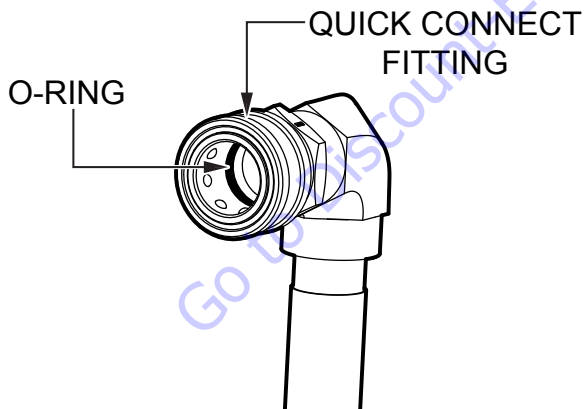

Figure 20. O-Ring Inspection

4. Inspect all hose fitting connections, including the compressor port. Make sure the suction hose connection to the **IN** port on the pump is tightly secured. A loose connection will cause air to be drawn into the line, and the pump will not prime itself properly.

5. Inspect the spray gun and spray tips for damage or wear. Replace if necessary.

COMPRESSOR OIL

1. Remove the compressor dipstick and check the compressor oil level shown on the dipstick (Figure 21). The oil should be between the dipstick's minimum and maximum marks. If the oil level is low, fill with the recommended oil type (Table 7). Maximum compressor oil capacity is 0.094 quarts (0.09 liters).

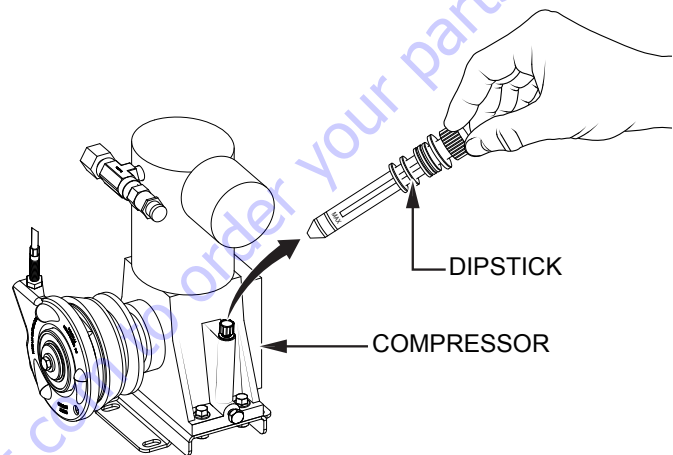

Figure 21. Checking Compressor Oil

Table 7. Compressor Oil Type

Ambient Temperature		
Below 32°F (0°C)	32°F (0°C) to 68°F (20°C)	68°F (20°C) to 104°F (40°C)
SAE 10W or ISO 32	SAE 20W or ISO 68	SAE 30W or ISO 100

TIRE PRESSURE

Inspect the wheels and check the front tire air pressure. The two front tires should be inflated to approximately 28 psig.

CHEMICAL SUPPLY

For best results, make sure the material to be sprayed is mixed properly according to manufacturer's recommendations, and has an even consistency.

INITIAL START-UP

It is **extremely important** that this section is read carefully before attempting to use the spray cart in the field. **DO NOT** use your spray cart until this section is thoroughly understood.

WARNING

Failure to understand the operation of the spray cart can result in **severe personal injury** or damage to the unit. Refer to Figure 6, Figure 7, Figure 8, Figure 9, and Figure 10 for the location of any components referenced in this manual.

CAUTION



DO NOT operate the spray cart in a confined area or enclosed structure that does not provide ample free flow of air.

NOTICE

DO NOT pump or spray whitewash, paints, or other abrasive liquids. **DO NOT** use rusty supply containers or sandy water.

1. Place the fuel valve lever in the **ON** position (Figure 22).

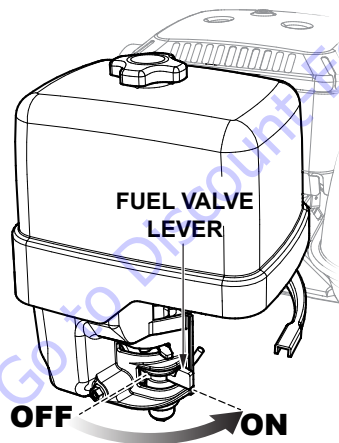

Figure 22. Fuel Valve Lever (ON)

2. To start a cold engine, or to start the engine in cold weather, move the choke lever (Figure 23) to the **CLOSED** position.

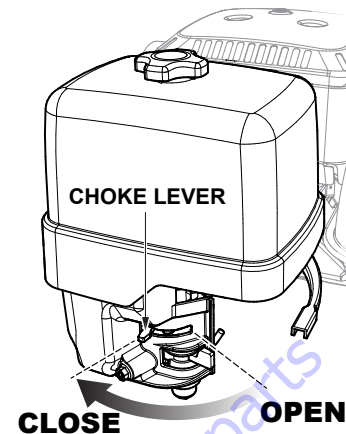

Figure 23. Choke Lever (CLOSED)

3. Move the throttle lever (Figure 24) away from the **SLOW** position, about 1/3 of the way toward the **FAST** position.

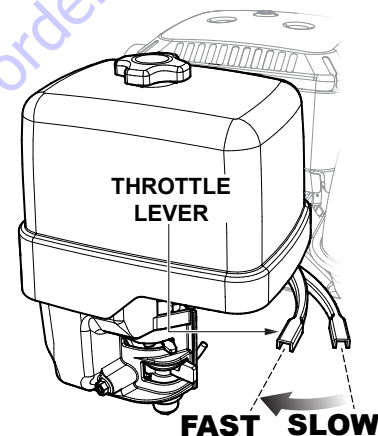

Figure 24. Throttle Lever Adjustment

4. Turn the engine **ON/OFF** switch to the **ON** position (Figure 25).

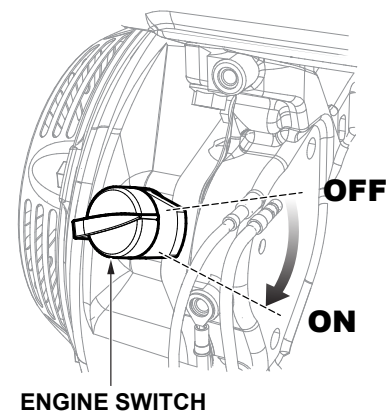

Figure 25. Engine ON/OFF Switch (ON)

5. Slowly pull the recoil starter grip (Figure 26) until resistance is felt, then pull briskly and smoothly to start the engine. Gently return the starter grip to its original position.

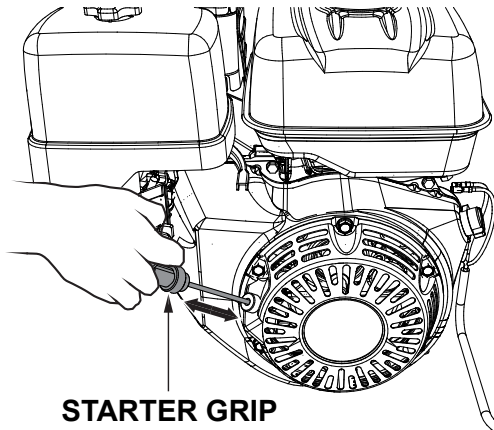

Figure 26. Starter Grip

OPERATION

Steering and Parking

1. Use the gripped control handles at the rear of the spray cart to steer the unit (Figure 27).

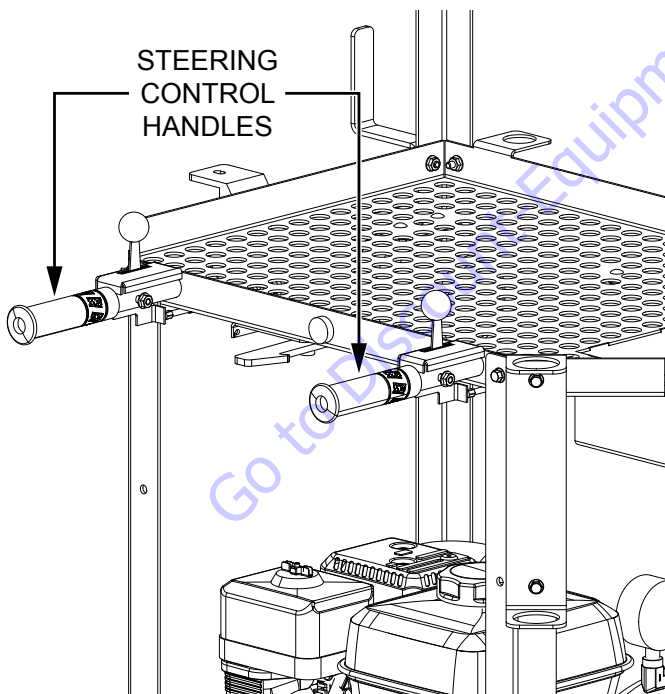

Figure 27. Steering Control Handles

2. Park the spray cart near the application area and engage the parking brake (Figure 28) to prevent the unit from rolling during use.

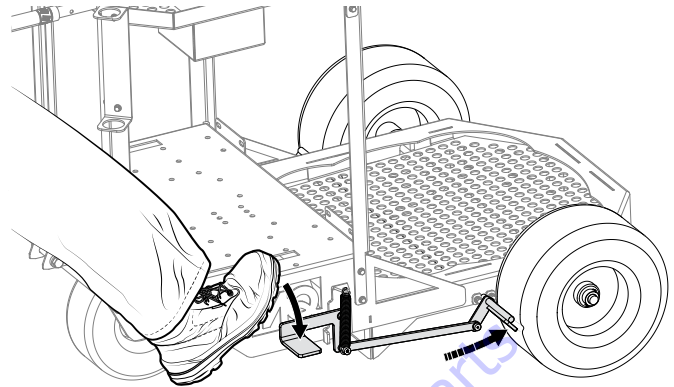

Figure 28. Engage Parking Brake

Control Levers

Once the engine has been started, use the control levers located at the rear of the spray cart (Figure 29) to engage the pump and compressor. The right lever engages the pump, and the left lever engages the compressor.

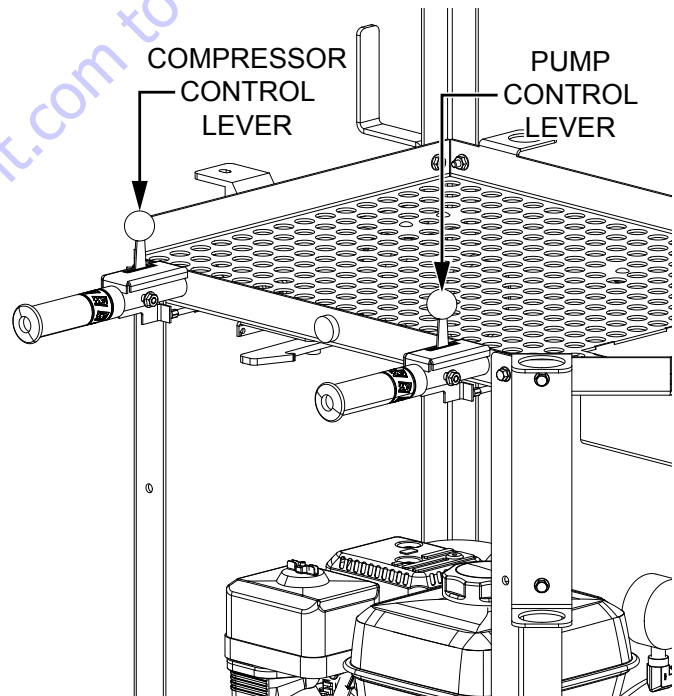

Figure 29. Pump and Compressor Control Levers

Pump

NOTICE

DO NOT run the pump dry. Excessive heat will damage the pump's rollers and seals.

1. To activate the pump, push the pump control lever forward until it latches in the forward position (Figure 30). The self-priming pump will begin to displace liquid within a few seconds.

NOTICE

A squirt of oil into the inlet side of the pump before starting will accelerate the priming action.

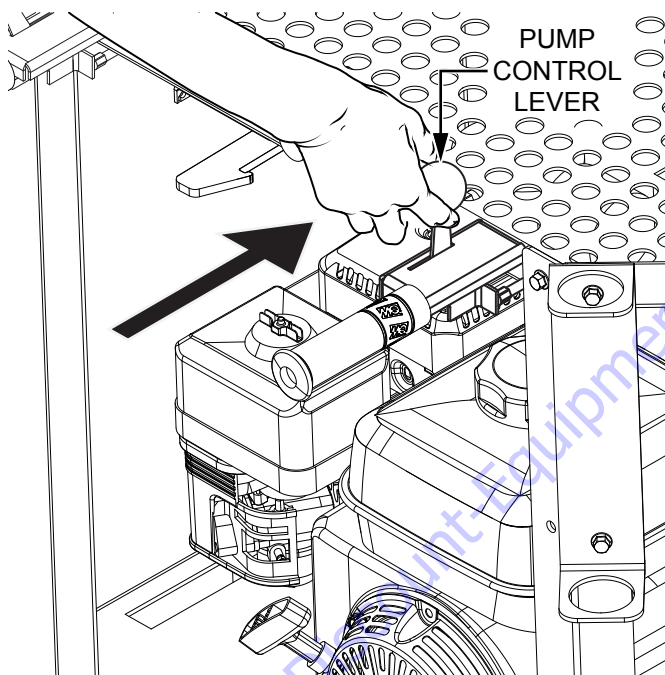

Figure 30. Engage Pump

2. Make sure the appropriate spray tip for the desired application is installed onto the spray gun (Figure 31). Always refer to the chemical manufacturer's recommendations when selecting a spray tip. Refer to Table 8 for spray tip selection information.

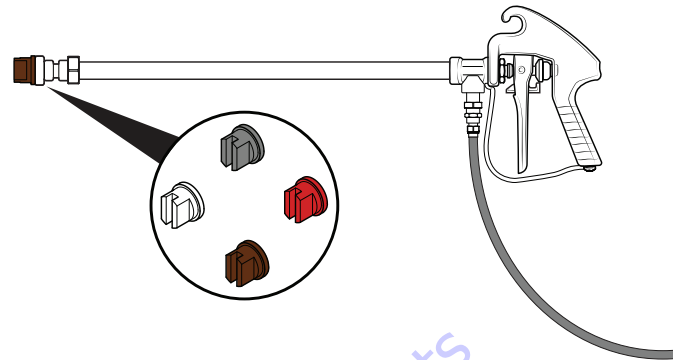

Figure 31. Spray Tip Installation

3. Aim the spray gun and pull the trigger to disperse liquids onto their final application (Figure 32). Release the spray gun trigger to stop dispersion.

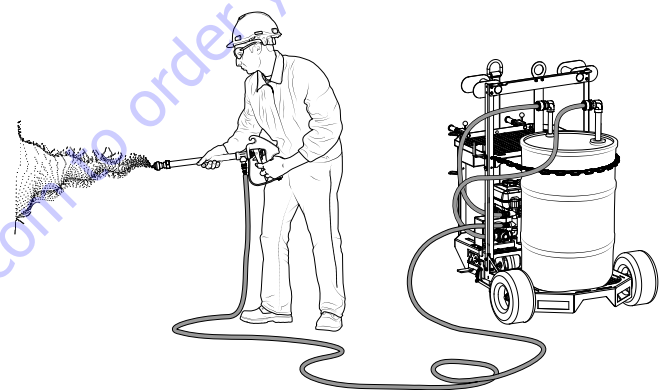

Figure 32. Liquid Dispersion

4. Turn the pressure regulator on the pump (Figure 33) to adjust the spray pressure as needed.

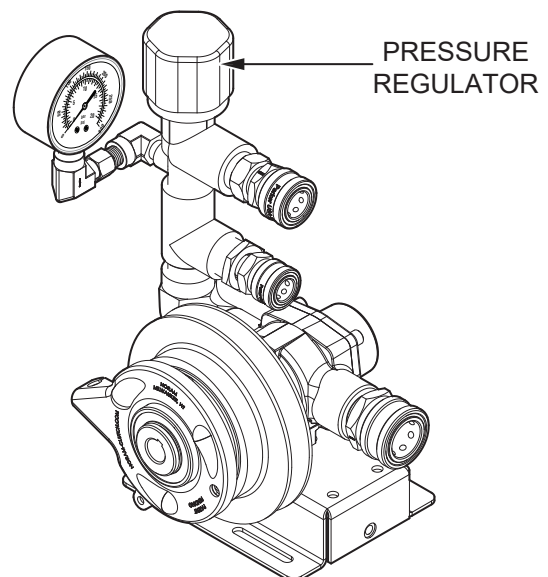

Figure 33. Pressure Regulator

- Slide the pump control lever sideways to unlatch, then pull back on the lever to disengage the pump (Figure 34).

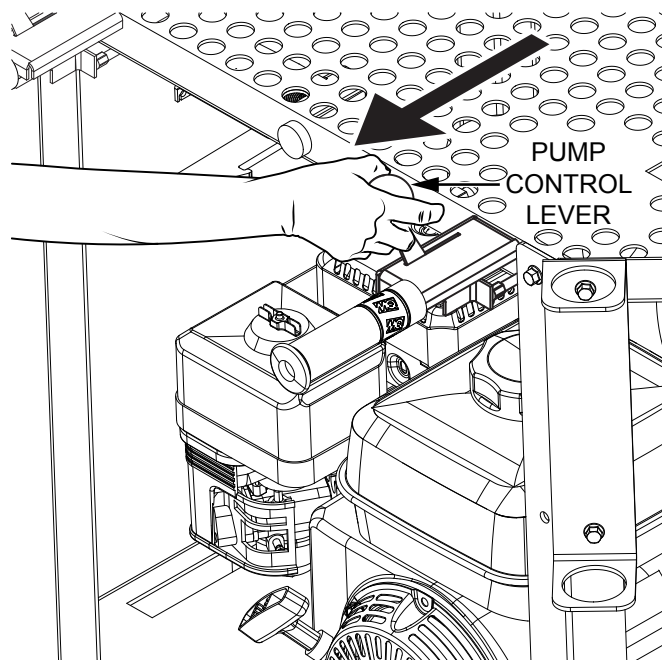

Figure 34. Disengage Pump

Compressor

Perform the following procedure to use the onboard air compressor to clear liquid from the spray system after use.

- Push the compressor control lever forward until it latches in the forward position (Figure 35), and let the compressor run for 1–2 minutes. This will bring the internal pressure up to approximately 20 psig, resulting in even lubrication of the compressor's internal components.

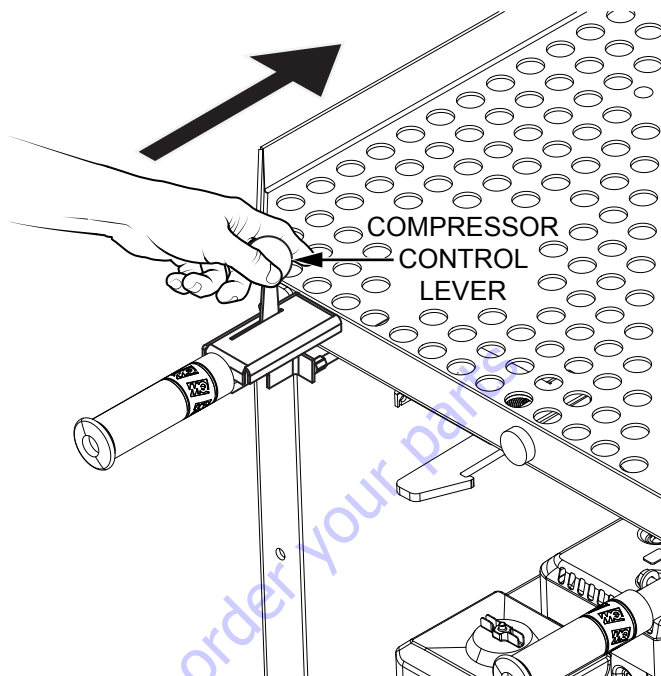

Figure 35. Engage Compressor

- Slide the compressor control lever sideways to unlatch, then pull back on the lever to disengage the compressor (Figure 36).

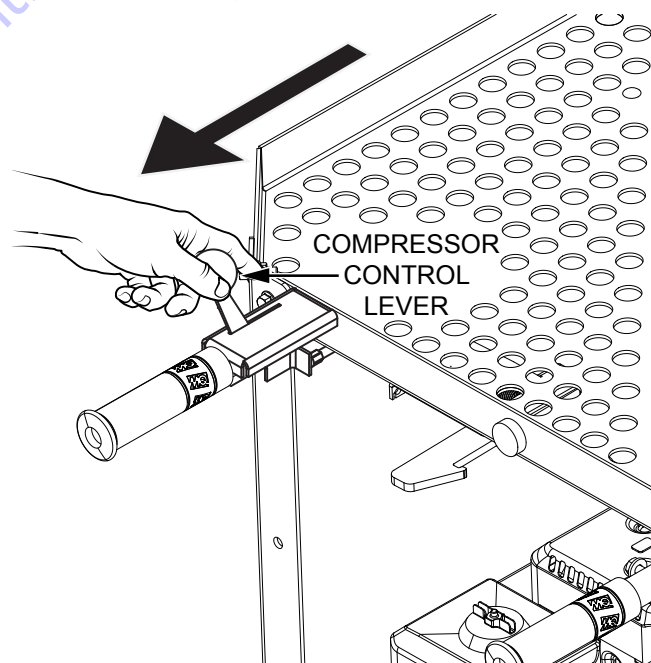

Figure 36. Disengage Compressor

3. Disconnect the suction hose from the quick-connect fitting on the suction tube (Figure 37). Leave the other end of the suction hose connected to the pump.

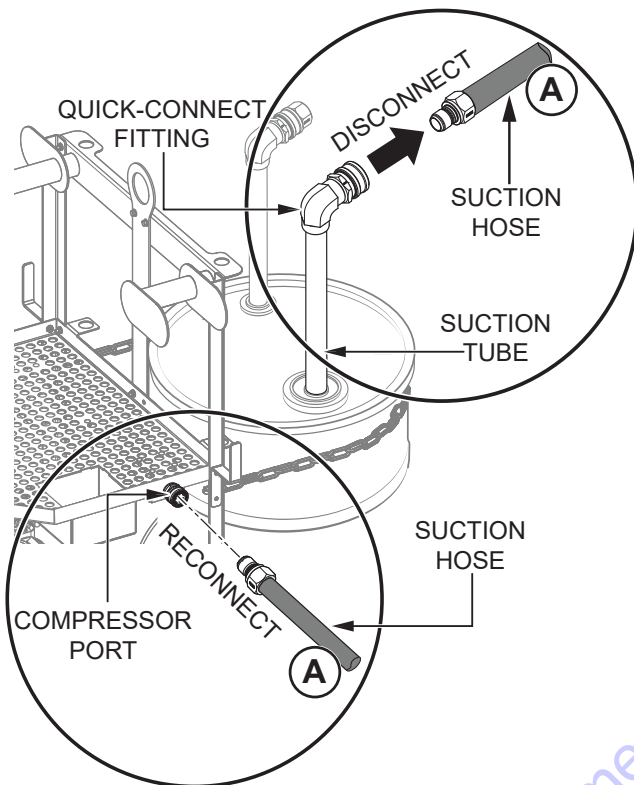

Figure 37. Compressor Connection

4. Connect the free end of the suction hose (Figure 37) to the compressor port on the right side of the spray cart.
5. Push the compressor control lever forward until it latches in the forward position (Figure 38), and let the compressor run for 10–15 seconds. Any liquid remaining in the suction and return hoses will flow through the return tube back into the supply container.

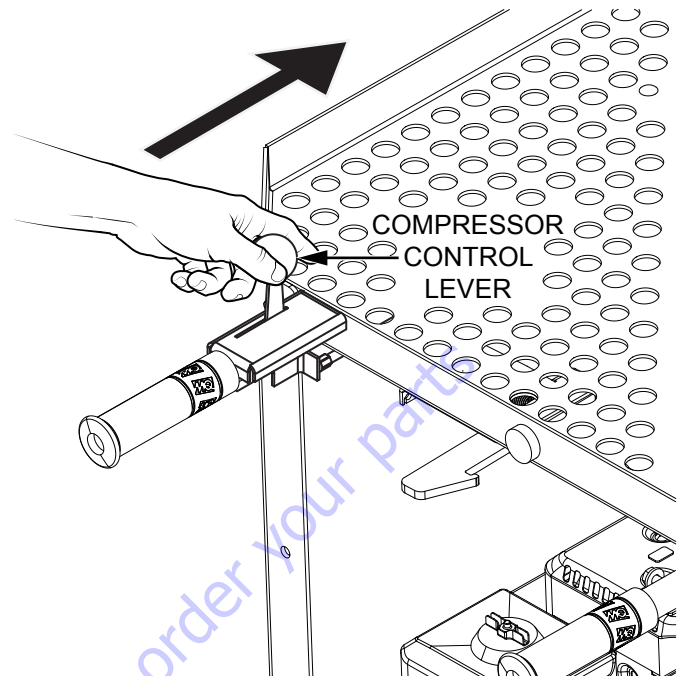

Figure 38. Engage Compressor

6. With the compressor still engaged, squeeze the spray gun trigger and hold it until all remaining liquid has been purged from the main hose and spray gun (Figure 39). It is recommended to remove the suction tube and aim the spray gun into the supply container while purging.

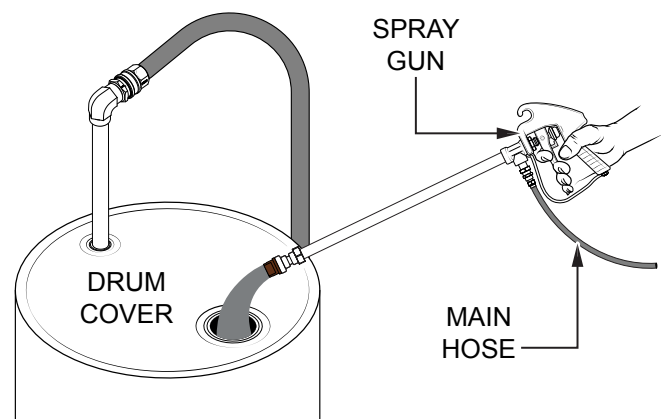

Figure 39. Purge Main Hose and Spray Gun

OPERATION

- Slide the compressor control lever sideways to unlatch, then pull back on the lever to disengage the compressor (Figure 40).

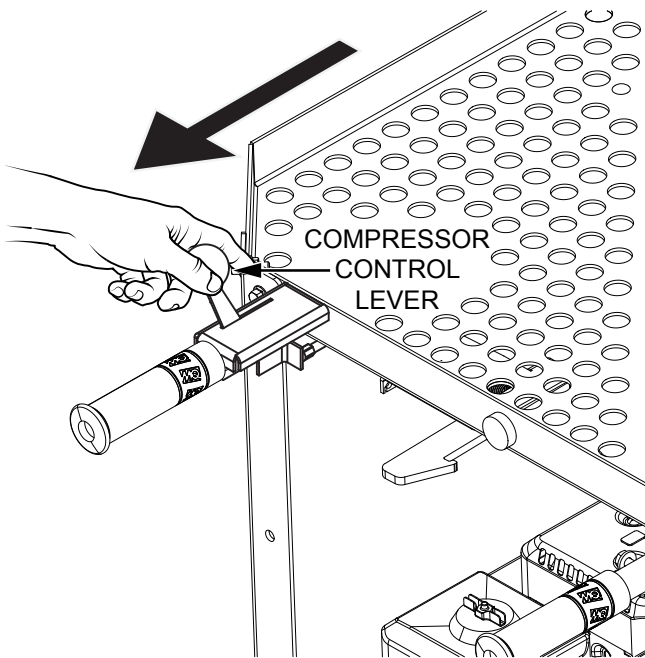

Figure 40. Disengage Compressor

- Disconnect the suction hose from the compressor port and reconnect it to the suction tube.

Stopping the Engine

- Place the throttle lever in the **SLOW** (idle) position, and let the engine idle for 3–5 minutes. See Figure 41.

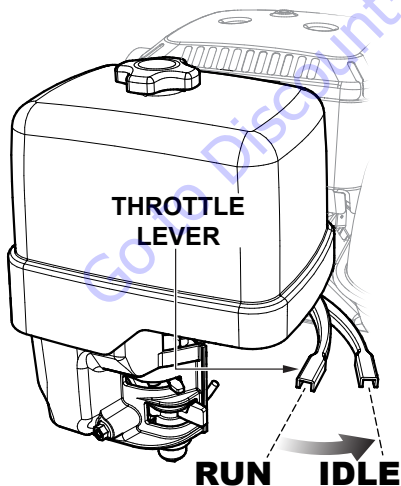

Figure 41. Throttle Lever (SLOW)

- Turn the engine **ON/OFF** switch to the **OFF** position (Figure 42).

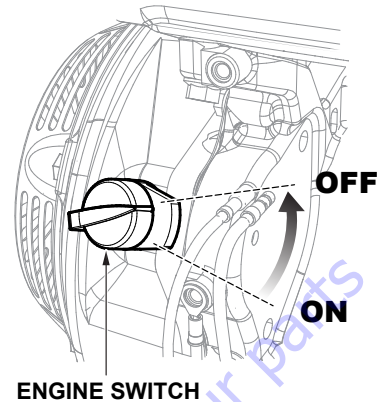

Figure 42. Engine ON/OFF Switch (OFF)

- Place the fuel valve lever in the **OFF** position (Figure 43).

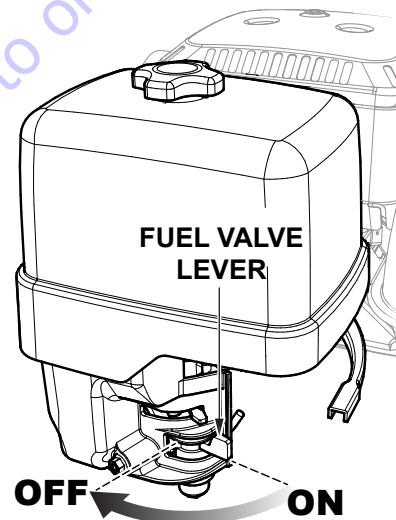

Figure 43. Fuel Valve Lever (OFF)

SPRAY TIPS

Four flat, extended-range spray tips are provided with the spray assembly. The design of the spray tips reduces spray drift at lower pressures, and increases spray coverage at higher pressures. Always refer to the chemical manufacturer's recommendations when selecting a spray tip. See Table 8 for spray tip selection information.

Table 8. Spray Tip Specifications				
Color	PSI	Droplet Size		Capacity (GPM)
		80°	100°	
Red	15	Coarse	Medium	0.24
	20	Medium	Medium	0.28
	30	Medium	Medium	0.35
	40	Medium	Medium	0.40
	50	Fine	Fine	0.45
	60	Fine	Fine	0.49
Brown	15	Coarse	Medium	0.31
	20	Coarse	Medium	0.35
	30	Medium	Medium	0.43
	40	Medium	Medium	0.50
	50	Medium	Fine	0.56
	60	Fine	Fine	0.61
Grey	15	Coarse	Coarse	0.37
	20	Coarse	Medium	0.42
	30	Medium	Medium	0.52
	40	Medium	Medium	0.60
	50	Medium	Medium	0.67
	60	Medium	Fine	0.73
White	15	Very Coarse	Coarse	0.49
	20	Very Coarse	Coarse	0.57
	30	Coarse	Coarse	0.69
	40	Medium	Medium	0.80
	50	Medium	Medium	0.89
	60	Medium	Medium	0.98

NOTICE

The preceding spray tip specifications are based on spraying **water**. These specifications will vary when spraying liquids that are heavier or lighter than water.

BARREL MOUNT

The chemical spray system is available as a stationary barrel mount option (Model WSC55BM). A compressor is not provided with the barrel mount. Perform the following procedure to prepare the barrel mount unit for operation.

1. Place the barrel mount in an area free of dirt and debris, and make sure it is on a secure, level surface.
2. Secure the two hose racks to the barrel mount with four flange screws and flange nuts as shown in Figure 44.

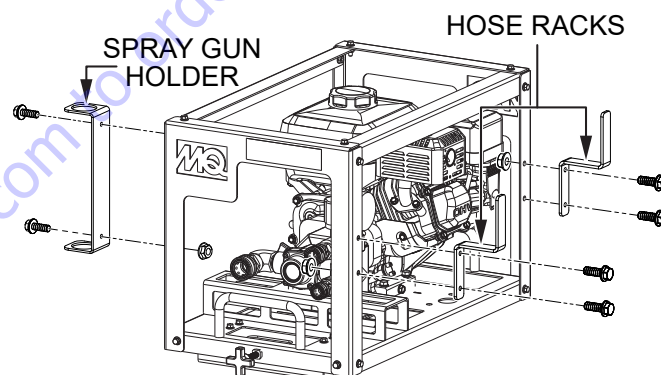

Figure 44. Barrel Mount Assembly

3. Secure the spray gun holder to the opposite side of the barrel mount with two flange screws and flange nuts as shown in Figure 44.

4. Make sure your 55-gallon (208-liter) supply drum is located on flat, stable ground. Carefully lift the barrel mount onto the top of the drum (Figure 45). Make sure the unit rests **between** the bung holes in the drum cover.

CAUTION

DO NOT attempt to lift the barrel mount by yourself. **ALWAYS** have a second person help lift the unit. **ALWAYS** use proper lifting techniques to avoid injury.

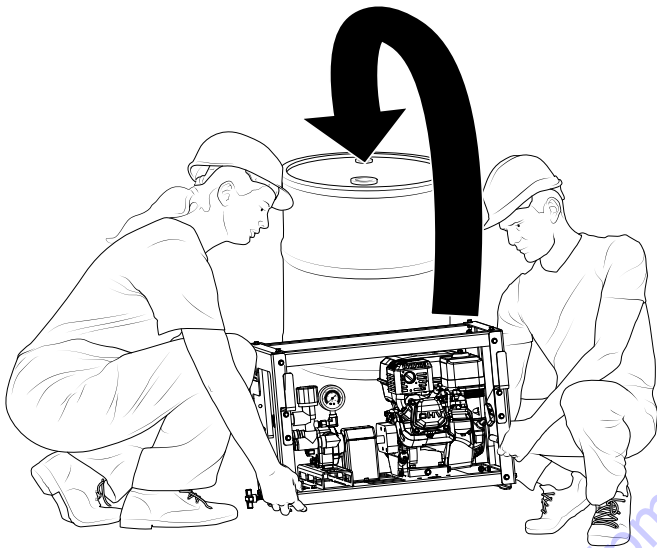

Figure 45. Barrel Mount Placement

5. Make sure the end of the barrel mount opposite the thumb screw is pressed flush against the drum cover, and turn the thumb screw to secure the barrel mount to the drum (Figure 46).

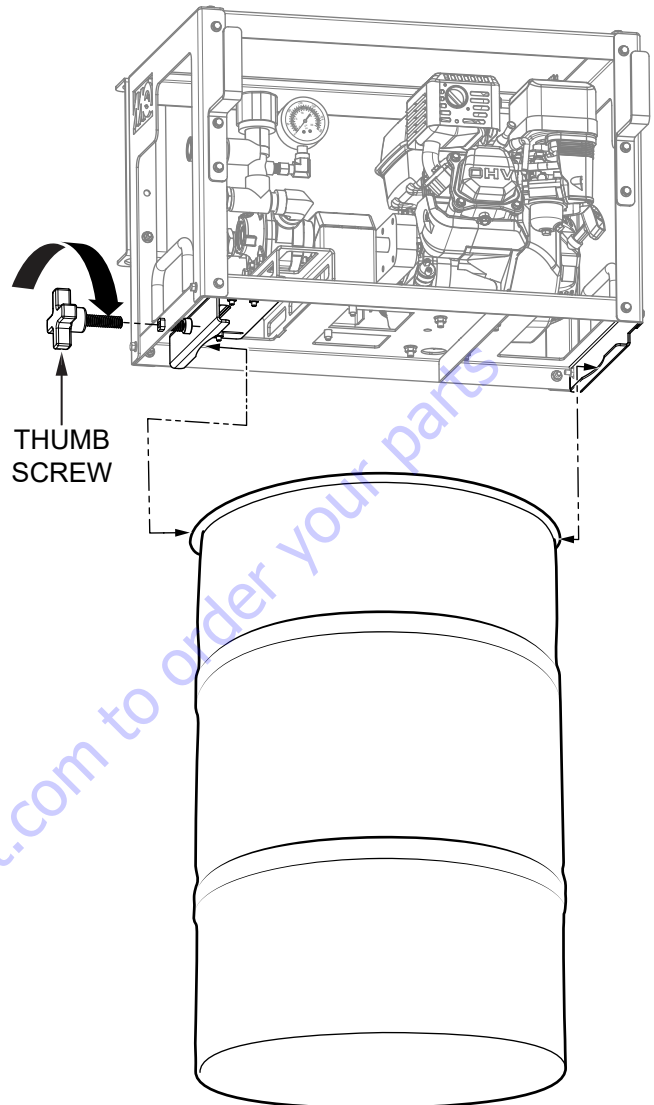

Figure 46. Secure Barrel Mount to Drum

6. Locate the bung holes on top of the drum. Break the bung hole cap seals (if necessary) and unscrew the bungs (plugs) to remove.

7. Insert the (**larger**) suction tube and (**smaller**) return tube into the top of the drum (Figure 47). If the bung holes are different sizes, be sure to place the suction tube into the **larger** hole, and the return tube into the **smaller** hole.

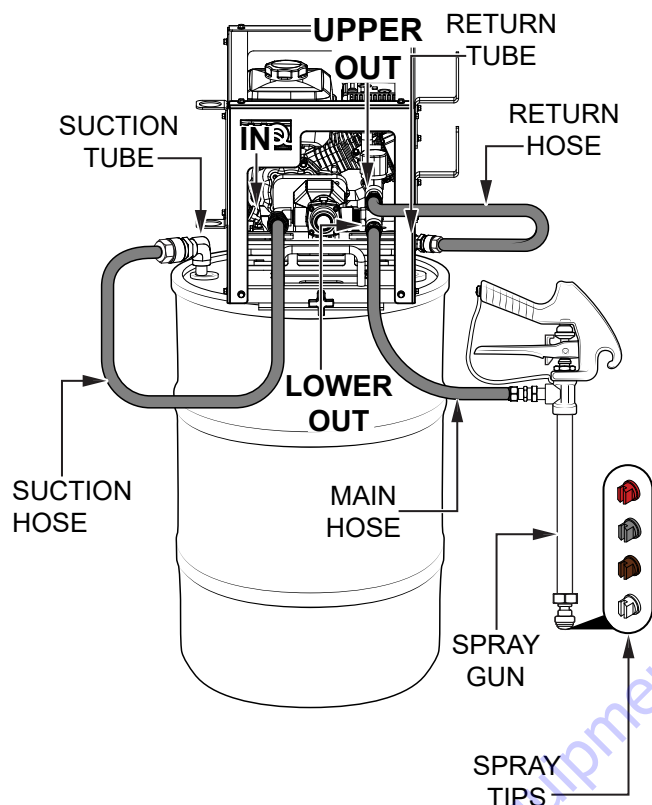

Figure 47. Barrel Mount Spray System Assembly

8. Connect one end of the suction hose to the **IN** port on the pump (Figure 47).
9. Connect the other end of the suction hose to the suction tube (Figure 47).
10. Connect one end of the return hose to the upper **OUT** port on the pump (Figure 47).
11. Connect the other end of the return hose to the return tube (Figure 47).
12. Connect the male fitting on one end of the main hose to the lower **OUT** port on the pump (Figure 47).
13. Connect the female fitting on the other end of the main hose to the male fitting on the spray gun (Figure 47).
14. Choose an appropriate spray tip for the desired application, and install it onto the end of the spray gun (Figure 47). See Table 8 for spray tip selection information.
15. Make sure all spray system connections are secure.

MAINTENANCE (ENGINE)

Use the following table as a general maintenance guideline when servicing your engine. For more detailed engine maintenance information, refer to the engine owner's manual supplied with your engine.

Engine Maintenance Schedule							
Description (3)	Operation	Daily	First Month or 10 Hrs.	Every 3 Months or 25 Hrs.	Every 6 Months or 50 Hrs.	Every Year or 100 Hrs.	Every 2 Years or 200 Hrs.
Engine Oil	Check	X					
	Change		X		X		
Air Cleaner	Check	X					
	Change			X (1)			
All Nuts and Bolts	Re-tighten if necessary	X					
Spark Plug	Check/Clean				X		
	Replace						X
Cooling Fins	Check				X		
Spark Arrester	Clean					X	
Fuel Tank	Clean					X	
Fuel Filter	Check					X	
Idle Speed	Check/Adjust					X (2)	
Valve Clearance	Check/Adjust						X (2)
Fuel Lines	Check	Every 2 years (replace if necessary) (2)					

(1) Service more frequently when used in **dusty** areas.

(2) These items should be serviced by your service dealer unless you have the proper tools and are mechanically proficient. Refer to the manufacturer's engine shop manual for service procedures.

(3) For commercial use, log hours of operation to determine proper maintenance intervals.

MAINTENANCE (ENGINE)

When performing maintenance on the spray cart or engine, follow all **Safety Messages** and **Rules for Safe Operation** appearing at the beginning of this manual.

ENGINE MAINTENANCE

Spark Plug

1. Remove and clean the spark plug (Figure 48) with a wire brush.

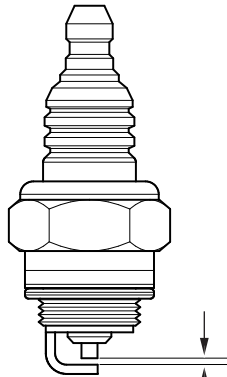

GAP: 0.028 – 0.031 in.
(0.7 – 0.8 mm)

Figure 48. Spark Plug

2. Measure the spark plug gap (Figure 48) with a feeler gauge. The spark plug gap should measure 0.028–0.031 inch (0.7–0.8 mm). Adjust the spark plug gap as needed by bending the side electrode.

Engine Oil

NOTICE

ALWAYS drain the engine oil while the oil is **warm**.

Refer to Figure 49.

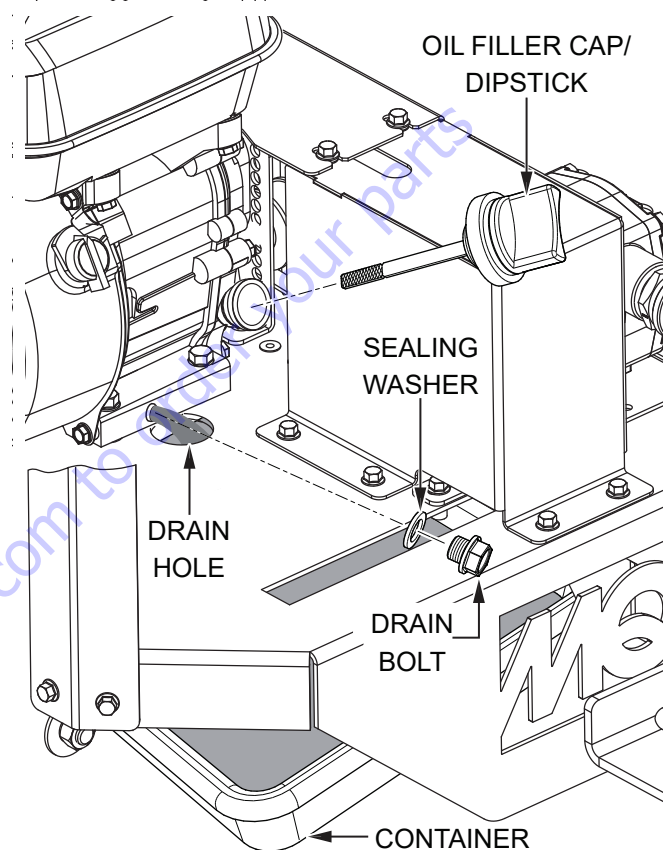

Figure 49. Engine Oil Replacement

1. Remove the oil filler cap/dipstick and set aside.
2. Remove the oil drain bolt and sealing washer. Allow the oil to drain into a suitable container through the drain hole in the spray cart frame.
3. Reinstall the oil drain bolt and sealing washer, and tighten securely.
4. Add engine oil as recommended in Table 6. For engine oil capacity, see Table 2. **DO NOT** overfill.
5. Reinstall the oil filler cap/dipstick.

MAINTENANCE (ENGINE)

Air Cleaner

Refer to Figure 50.

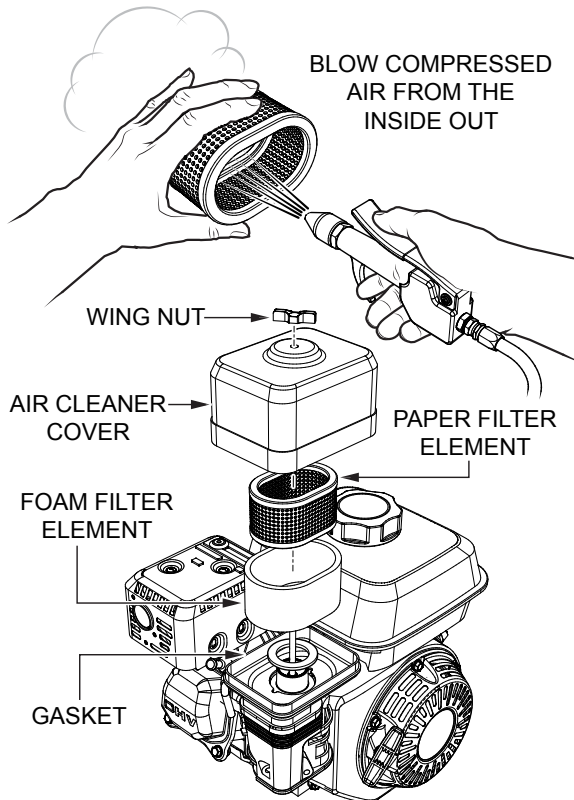

Figure 50. Air Cleaner Maintenance

1. Remove the wing nut, air cleaner cover, and foam filter element, and set them aside.
2. To remove dirt, tap the paper filter element several times on a hard surface, or blow compressed air not exceeding 30 psig (207 kPa, 2.1 kgf/cm²) through the filter element from the inside out. **NEVER** brush off dirt. Brushing will force dirt into the fibers. Replace the paper filter element if it is excessively dirty.
3. Clean the foam filter element in warm, soapy water or a nonflammable solvent. Rinse and dry thoroughly. Dip the element in clean engine oil, and completely wring out all excess oil from the element.

! DANGER

To prevent a possible fire or explosion, **NEVER** use gasoline as a cleaning solvent.

4. Reinstall the foam and paper elements and air cleaner cover, and secure with the wing nut.

Spark Arrester

1. Remove and retain the four 5 mm screws securing the muffler protector to the muffler (Figure 51). Remove the muffler protector and set it aside.

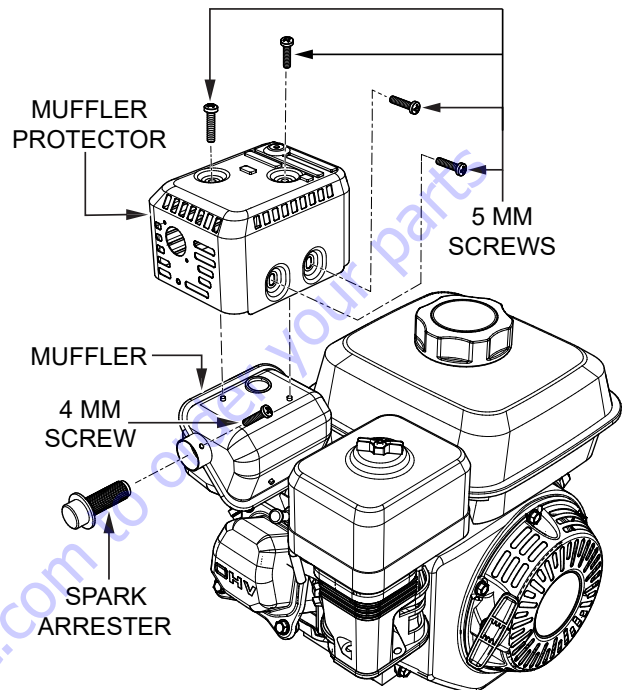

Figure 51. Spark Arrester Access

2. Remove and retain the 4 mm screw securing the spark arrester to the muffler, and remove the spark arrester (Figure 51).
3. Carefully remove carbon deposits from the spark arrester screen with a wire brush (Figure 52). If the spark arrester is damaged (has breaks or holes), replace it with a new one.

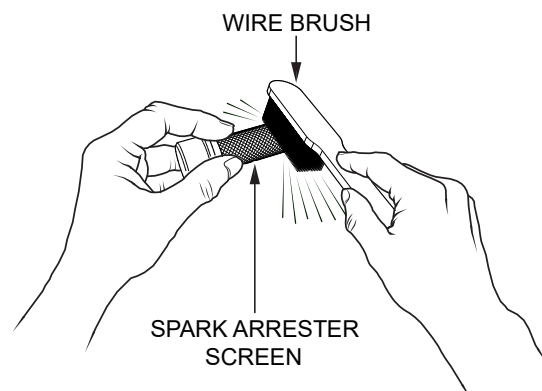

Figure 52. Spark Arrester Cleaning

MAINTENANCE (SPRAY CART)

Use the following table as a general maintenance guideline when servicing your spray cart.

Spray Cart Maintenance Schedule							
Description (2)	Operation	Daily	Weekly	Monthly	Every 60 Days or 200 Hrs.	Every 3 Months or 300 Hrs.	Every Year or 1000 Hrs.
Flush and rinse pump	Clean	X					
Pump belt tension	Check	X					
Pump filters	Check	X					
Check pump for leaks	Check	X					
Clear hoses with air compressor	Clean	X					
Drain moisture from compressor piping	Clean	X					
Compressor intake air filters	Clean		X (1)				
Compressor V-belts	Check/Adjust		X (1)				
Compressor cylinders, cylinder head, motor, fan blade, tubing, and tank	Clean		X (1)				
Compressor lubricant	Check	X					
	Replace				X (1)		
Check compressor for air leakage	Check			X (1)			
Compressor air filter element	Replace					X (1)	
Compressor fasteners	Check/Adjust					X (1)	
Test and calibrate compressor pressure switch, pressure gauge, and safety valve	Check/Adjust						X (1)
Compressor suction and discharge valve plates	Check/Clean						X (1)

(1) Service more frequently when used in **dusty** areas.

(2) For commercial use, log hours of operation to determine proper maintenance intervals.

MAINTENANCE (SPRAY CART)

SPRAY CART MAINTENANCE

Pump

After each use, thoroughly flush the pump with a neutralizing solution for the liquid that was just pumped. Follow with a clean water rinse.

LONG-TERM STORAGE

When storing the spray cart for more than 30 days, perform the following procedure:

- Drain the pump thoroughly, and open any drain plugs.
- Remove all hoses from the pump and blow the pump dry with air.
- Inject an antifreeze/rust inhibitor into the pump and plug all pump ports.
- Drain the fuel tank completely, or add STA-BIL® to the fuel.
- Run the engine until all gasoline in the carburetor is completely consumed.
- Completely drain the oil from the crankcase and refill with fresh oil.
- Remove the spark plug, pour 2–3 cm³ of SAE 30 oil into the cylinder, and crank slowly to distribute the oil.
- Slowly pull the recoil starter grip and stop at the compression point.
- Wipe the spray cart clean with a cloth.
- Cover the spray cart with a plastic sheet and store it out of direct sunlight, in a moisture-free and dust-free location.

Go to Discount-Equipment.com to order your parts

TROUBLESHOOTING (ENGINE)

Troubleshooting (Engine)		
Symptom	Possible Problem	Solution
Difficult to start, fuel is available, but no spark at spark plug.	Spark plug bridging?	Check gap, insulation or replace spark plug.
	Carbon deposit on spark plug?	Clean or replace spark plug.
	Short circuit due to deficient spark plug insulation?	Check spark plug insulation, replace if worn.
	Improper spark plug gap?	Set to proper gap.
	Spark plug is red?	Check transistor ignition unit.
	Spark plug is bluish white?	If insufficient compression, repair or replace engine. If injected air leaking, correct leak. If carburetor jets clogged, clean carburetor.
	No spark present at tip of spark plug?	Check if transistor ignition unit is broken, and replace defective unit. Check if voltage cord cracked or broken and replace. Check if spark plug if fouled and replace.
	No oil?	Add oil as required.
	Oil pressure alarm lamp blinks upon starting? (if applicable)	Check automatic shutdown circuit, "oil sensor". (if applicable)
Difficult to start, fuel is available, and spark is present at the spark plug.	ON/OFF switch is shorted?	Check switch wiring, replace switch.
	Ignition coil defective?	Replace ignition coil.
	Improper spark gap, points dirty?	Set correct spark gap and clean points.
	Condenser insulation worn or short circuiting?	Replace condenser.
	Spark plug wire broken or short circuiting?	Replace defective spark plug wiring.
Difficult to start, fuel is available, spark is present and compression is normal.	Wrong fuel type?	Flush fuel system, replace with correct type of fuel.
	Water or dust in fuel system?	Flush fuel system.
	Air cleaner dirty?	Clean or replace air cleaner.
	Choke open?	Close choke.
Difficult to start, fuel is available, spark is present and compression is low.	Suction/exhaust valve stuck or protruded?	Reseat valves.
	Piston ring and/or cylinder worn?	Replace piston rings and/or piston.
	Cylinder head and/or spark plug not tightened properly?	Torque cylinder head bolts and spark plug.
No fuel present at carburetor.	Head gasket and/or spark plug gasket damaged?	Replace head and spark plug gaskets.
	No fuel in fuel tank?	Fill with correct type of fuel.
	Fuel cock does not open properly?	Apply lubricant to loosen fuel cock lever, replace if necessary.
	Fuel filter/lines clogged?	Replace fuel filter.
	Fuel tank cap breather hole clogged?	Clean or replace fuel tank cap.
	Air in fuel line?	Bleed fuel line.

TROUBLESHOOTING (ENGINE)

Troubleshooting (Engine) - continued		
Symptom	Possible Problem	Solution
Weak in power, compression is proper and does not misfire.	Air cleaner dirty?	Clean or replace air cleaner.
	Improper level in carburetor?	Check float adjustment, rebuild carburetor.
	Defective spark plug?	Clean or replace spark plug.
	Improper spark plug?	Set to proper gap.
Weak in power, compression is proper but misfires.	Water in fuel system?	Flush fuel system and replace with correct type of fuel.
	Dirty spark plug?	Clean or replace spark plug.
	Ignition coil defective?	Replace ignition coil.
Engine overheats	Wrong type of fuel?	Replace with correct type of fuel.
	Cooling fins dirty?	Clean cooling fins.
	Intake air restricted?	Clear intake of dirt and debris. Replace air cleaner elements as necessary.
	Oil level too low or too high?	Adjust oil to proper level.
Rotational speed fluctuates.	Governor adjusted incorrectly?	Adjust governor.
	Governor spring defective?	Replace governor spring.
	Fuel flow restricted?	Check entire fuel system for leaks or clogs.
Recoil starter malfunctions. (if applicable)	Recoil mechanism clogged with dust and dirt?	Clean recoil assembly with soap and water.
	Spiral spring loose?	Replace spiral spring.
Starter malfunctions.	Loose, damaged wiring?	Ensure tight, clean connections on battery and starter.
	Battery insufficiently charged?	Recharge or replace battery.
	Starter damaged or internally shorted?	Replace starter.
Burns too much fuel.	Over-accumulation of exhaust products?	Check and clean valves. Check muffler and replace if necessary.
	Wrong spark plug?	Replace spark plug with manufacturer's suggested type.
Exhaust color is continuously "white".	Lubricating oil is wrong viscosity?	Replace lubricating oil with correct viscosity.
	Worn rings?	Replace rings.
Exhaust color is continuously "black".	Air cleaner clogged?	Clean or replace air cleaner.
	Choke valve set to incorrect position?	Adjust choke valve to correct position.
	Carburetor defective, seal on carburetor broken?	Replace carburetor or seal.
	Poor carburetor adjustment, engine runs too rich?	Adjust carburetor.
Will not start, no power with key "ON". (if applicable)	ON/OFF device not activated ON?	Turn on ON/OFF device.
	Battery disconnected or discharged?	Check cable connections. Charge or replace battery
	Ignition switch/wiring defective?	Replace ignition switch. Check wiring.

TROUBLESHOOTING (SPRAY CART)

Troubleshooting (Spray Cart)		
Symptom	Possible Problem	Solution
Pump does not prime	Leak in suction line?	Check hose and fittings for leaks and correct.
	Obstruction in suction line?	Inspect hose for obstructions such as debris or loose inner liner and remove from the line.
	Suction hose sucked to bottom or side of tank?	Cut a notch or "V" in end of suction hose.
	Rollers stuck in pump?	Disassemble pump and inspect rollers.
	Pump seals leaking air?	Replace seals.
	Pump turning in wrong direction?	Correct rotation of pump.
Loss of pump pressure	Clogged suction strainer?	Check strainer and clean regularly.
	Kinked or blocked suction hose?	Inspect suction hose and repair as necessary.
	Air leak in inlet side plumbing?	Check hose and connections for leaks. Use pipe joint sealant and retighten connections.
	Relief valve setting too low or weakened spring?	Check relief valve and correct setting or replace spring.
	Faulty gauge?	Replace gauge.
	Pump seals leak air?	Replace seals.
	Nozzle orifices worn?	Replace nozzles.
Pump worn?	Repair pump.	
Pump will not turn	Corrosion (rust), scale or residue?	Replace pump.
	Solid object lodged in pump?	Disassemble pump and remove object.
Pump hydraulic system overheating	Insufficient hydraulic hose size?	Check hydraulic hose size. Hose should be at least 1/2" (13 mm). For large open-center systems, hose should be 3/4" (19 mm).
Parking brake will not hold	Brake linkage out of adjustment?	Inspect brake linkage. Adjust linkage fasteners as necessary.
Erratic spray output—overapplying and underapplying	Worn or damaged spray tip?	Replace spray tip.

EXPLANATION OF CODE IN REMARKS COLUMN

The following section explains the different symbols and remarks used in the Parts section of this manual. Use the help numbers found on the back page of the manual if there are any questions.

NOTICE

The contents and part numbers listed in the parts section are subject to change **without notice**. Multiquip does not guarantee the availability of the parts listed.

SAMPLE PARTS LIST

NO.	PART NO.	PART NAME	QTY.	REMARKS
1	12345	BOLT.....	1	INCLUDES ITEMS W/%
2%		WASHER, 1/4 IN.....		NOT SOLD SEPARATELY
2%	12347	WASHER, 3/8 IN....	1	MQ-45T ONLY
3	12348	HOSE		A/R ...MAKE LOCALLY
4	12349	BEARING	1	S/N 2345B AND ABOVE

NO. Column

Unique Symbols — All items with same unique symbol

(@, #, +, %, or >) in the number column belong to the same assembly or kit, which is indicated by a note in the “Remarks” column.

Duplicate Item Numbers — Duplicate numbers indicate multiple part numbers, which are in effect for the same general item, such as different size saw blade guards in use or a part that has been updated on newer versions of the same machine.

NOTICE

When ordering a part that has more than one item number listed, check the remarks column for help in determining the proper part to order.

PART NO. Column

Numbers Used — Part numbers can be indicated by a number, a blank entry, or TBD.

TBD (To Be Determined) is generally used to show a part that has not been assigned a formal part number at the time of publication.

A blank entry generally indicates that the item is not sold separately or is not sold by Multiquip. Other entries will be clarified in the “Remarks” Column.

QTY. Column

Numbers Used — Item quantity can be indicated by a number, a blank entry, or A/R.

A/R (As Required) is generally used for hoses or other parts that are sold in bulk and cut to length.

A blank entry generally indicates that the item is not sold separately. Other entries will be clarified in the “Remarks” Column.

REMARKS Column

Some of the most common notes found in the “Remarks” Column are listed below. Other additional notes needed to describe the item can also be shown.

Assembly/Kit — All items on the parts list with the same unique symbol will be included when this item is purchased.

Indicated by:

“INCLUDES ITEMS W/(unique symbol)”

Serial Number Break — Used to list an effective serial number range where a particular part is used.

Indicated by:

“S/N XXXXX AND BELOW”

“S/N XXXX AND ABOVE”

“S/N XXXX TO S/N XXX”

Specific Model Number Use — Indicates that the part is used only with the specific model number or model number variant listed. It can also be used to show a part is NOT used on a specific model or model number variant.

Indicated by:

“XXXXX ONLY”

“NOT USED ON XXXX”

“Make/Obtain Locally” — Indicates that the part can be purchased at any hardware shop or made out of available items. Examples include battery cables, shims, and certain washers and nuts.

“Not Sold Separately” — Indicates that an item cannot be purchased as a separate item and is either part of an assembly/kit that can be purchased, or is not available for sale through Multiquip.

SUGGESTED SPARE PARTS

WSC55 SERIES CHEMICAL SPRAY CART

1 to 3 units

Qty.	P/N	Description
2	49273	BELT, AX26
2	49311	BELT, AX37
2	49308	CABLE, CART ENGAGE
1	49290	CLUTCH, PUMP MECH.
1	49289	CLUTCH, AIR MECH.
1	49261	PUMP, 4 ROLLER
1	49310	GAUGE, 300PSI LIQUID
1	49247	SPRAY, FLAT TIP BROWN
1	49250	SPRAY, FLAT TIP RED
1	49251	SPRAY, FLAT TIP GREY
1	49254	SPRAY, FLAT TIP WHITE
2	23611	GRIP, HANDLE

NOTICE

Part numbers on this Suggested Spare Parts list may supersede/replace the part numbers shown in the following parts lists.

HONDA GX160UT2LX2 GASOLINE ENGINE

1 to 3 units

Qty.	P/N	Description
3	9807955876	SPARK PLUG
2	17210ZE1517	ELEMENT, AIR (DUAL)
3	17218ZE1507	FILTER, OUTER
1	28462ZH8003	ROPE, RECOIL STARTER
1	17620Z4H900	CAP, FUEL

Go to Discount-Equipment.com to order your parts

NAMEPLATE AND DECALS

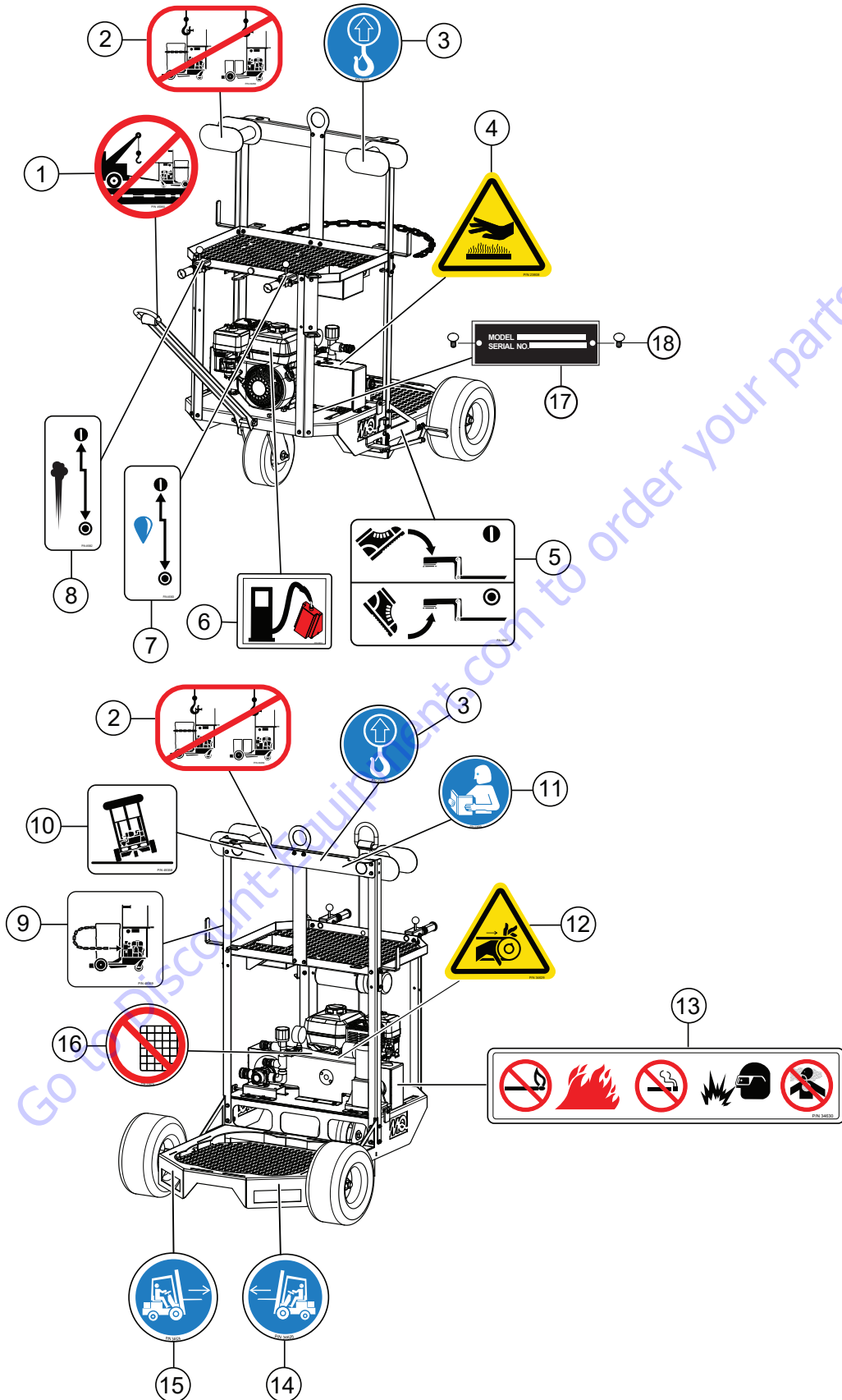

NAMEPLATE AND DECALS

<u>NO.</u>	<u>PART NO.</u>	<u>PART NAME</u>	<u>QTY.</u>	<u>REMARKS</u>
1	49360	ISO DECAL, DO NOT TOW ON STREET	1	
2	49264	ISO DECAL, DO NOT LIFT WITH BARREL/PAIS	1	
3	23805	ISO DECAL, LIFT LOCATION, 1.00" DIA	1	
4	23808	ISO DECAL, HOT SURFACE HAZARD	1	
5	49361	ISO DECAL, ENGAGE PARKING BRAKE	1	
6	23812	ISO DECAL, FUEL GASOLINE	1	
7	49363	ISO DECAL, ENGAGE PUMP	1	
8	49362	ISO DECAL, ENGAGE COMPRESSOR	1	
9	49359	ISO DECAL, SECURE DRUM	1	
10	49358	ISO DECAL, TIPPING HAZARD	1	
11	23699	ISO DECAL, READ MANUAL, 2.00" DIA.	1	
12	34629	ISO DECAL, ROTATING PART HAZARD	1	
13	34630	DECAL, FIRE, SMOKING, EXPLOSION, INHALATION HAZARD	1	
14	34624	ISO DECAL, FORKLIFT RIGHT	1	
15	34625	ISO DECAL, FORKLIFT LEFT	1	
16	23874	ISO DECAL, DO NOT REMOVE GUARDS HAZARD	1	
17		SERIAL PLATE, NON CE	1 CONTACTMQPARTS
18	4014	SCREW, 2-3/16" P-K	2	

Go to Discount-Equipment.com to order your parts

CART ASSY.

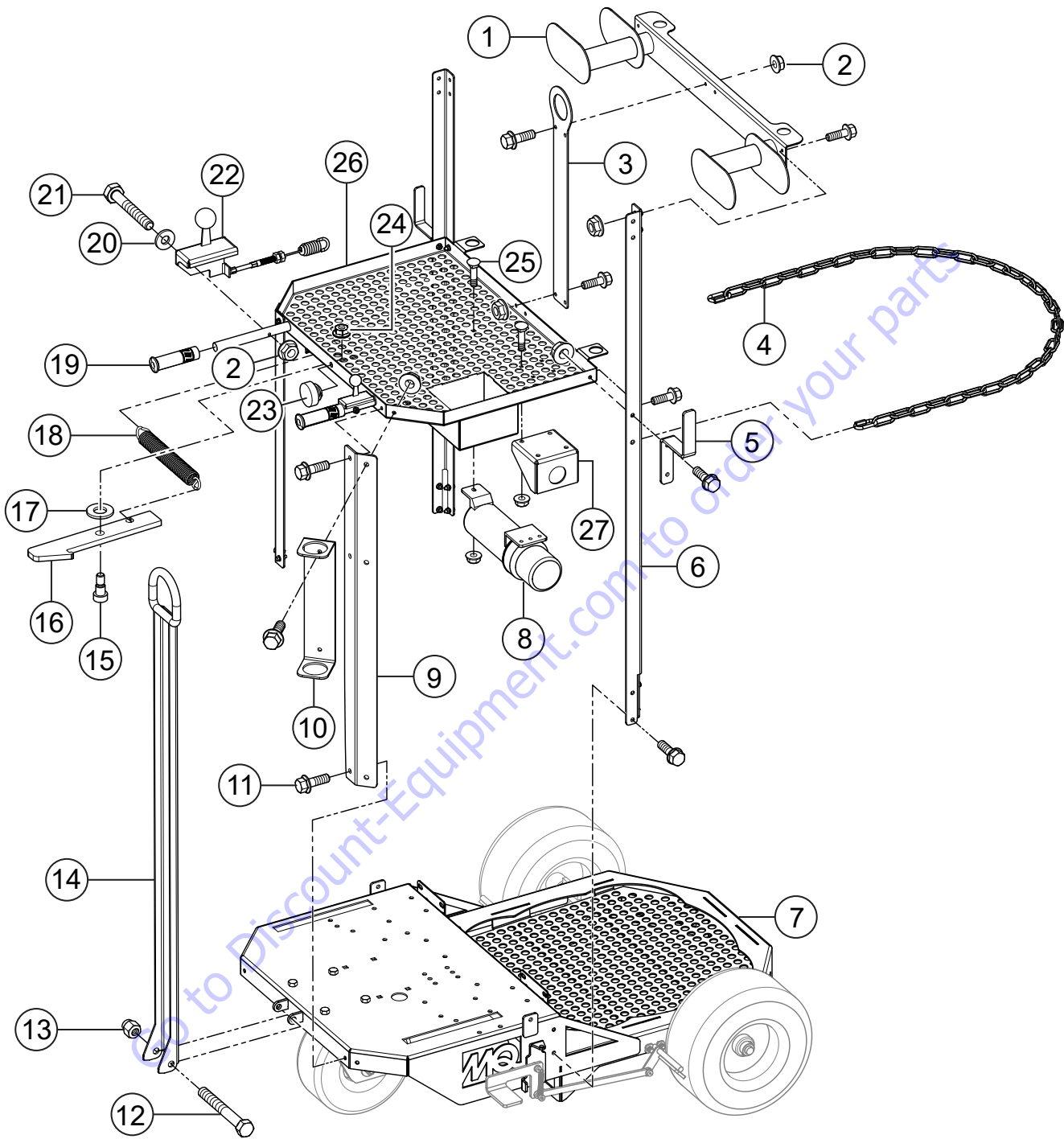

CART ASSY.

<u>NO.</u>	<u>PART NO.</u>	<u>PART NAME</u>	<u>QTY.</u>	<u>REMARKS</u>
1	49216	WRAP, HOSE	1	
2	49070	NUT, HFS, 1/4"-20	40	
3	49223	CRANE HOOK	1	
4	49242	CHAIN	1	
5	49215	HOLDER, HOSE	2	
6	49212	MOUNT, REAR FRAME	2	
7	49204	FRAME, BASE	1	
8	23297	MANUAL HOLDER	1	
9	49213	MOUNT, FRONT FRAME	2	
10	49214	HOLDER, SPRAY NOZZLE	1	
11	49048	SCREW, HHFS 1/4"-20 X 3/4" GRD 5	31	
12	8087	SCREW, HHC 1/2"-13 X 4	1	
13	10176	NUT, NYLOC 1/2"-13	1	
14	49221	HITCH, TOW	1	
15	3910382	BOLT, PLATED SHOULDER	1	
16	49350	LATCH, HITCH	1	
17	35235	WASHER, NYLON, 3/8" ID. X .06 THK	1	
18	18626-001	SPRING, TENSION-GUARD BLADE	1	
19	22762	GRIP, HANDLE	2	
20	0948	WASHER, FLAT SAE 1/4"	2	
21	26250	SCREW, HHC 1/4"-20 X 1-3/4"	2	
22	49308	CABLE, CART ENGAGE	2	
23	21597	BUMPER, STEM	1	
24	49071	NUT, HFS 5/16"-18	1	
25	29712	BOLT, CARRIAGE 1/4"-20 X 3/4"	7	
26	49225	TRAY, TOOL	1	
27	49252	BULKHEAD, CHEM. BLOWOUT	1	

Go to Discount-Equipment.com to order your parts

COMPRESSOR ASSY.

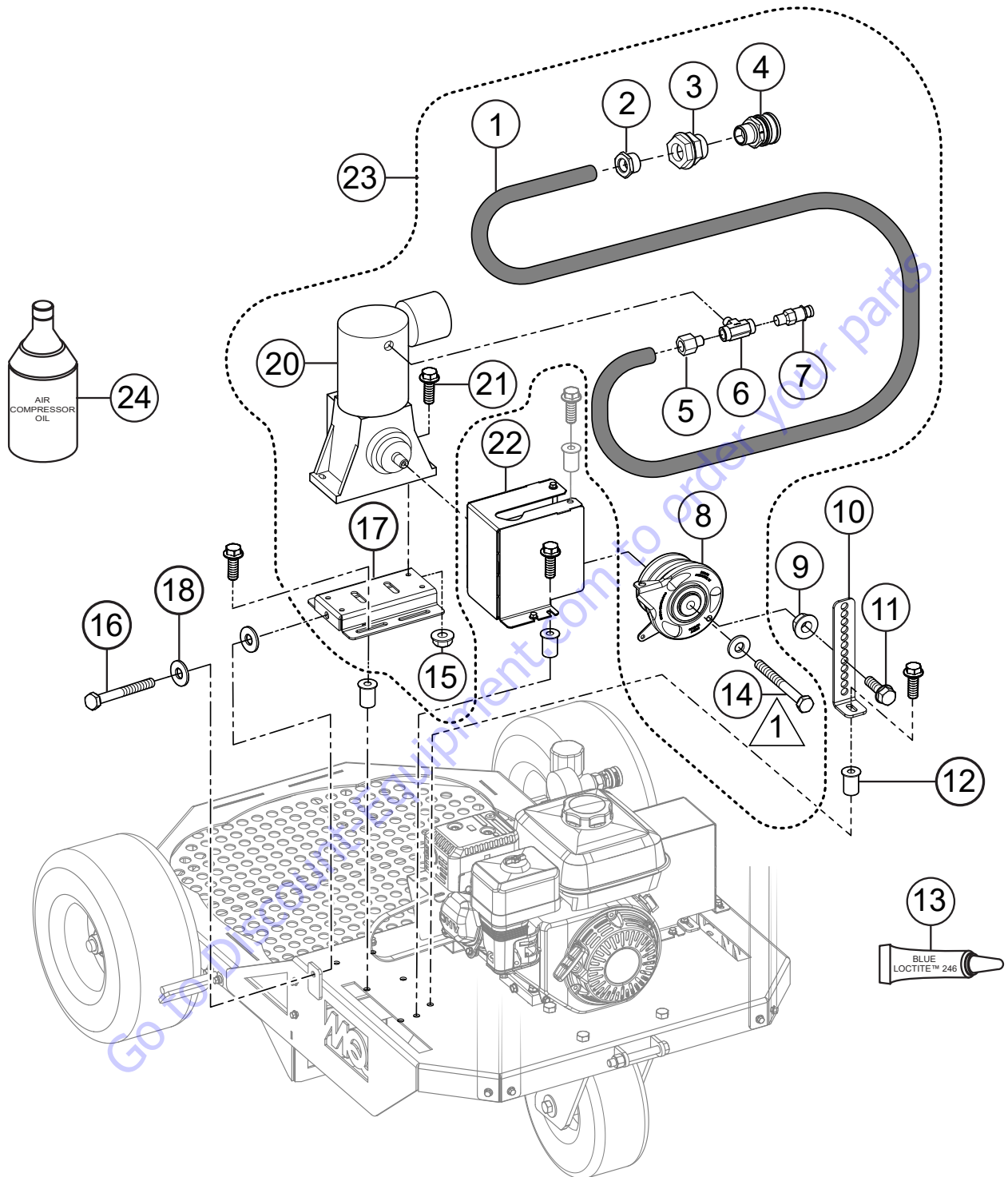

NOTE:

△ 1 APPLY LOCTITE™ 246.

COMPRESSOR ASSY.

<u>NO.</u>	<u>PART NO.</u>	<u>PART NAME</u>	<u>QTY.</u>	<u>REMARKS</u>
1#	49255	HOSE ASSY., 3/8" X 28" X 3/8"		
2#	49333	FITTING, BRASS 3/4" MNPT-3/8" FNPT	1	
3#	49256	FITTING, BULKHEAD 3/4" NPT	1	
4#	49326	FITTING, 3/4" MNPT FEMALE QUICK	1	
5#	49257	FITTING ADAPTOR 3/8" NPT X 1/4" NPT	1	
6#	32587	FITTING, BRASS TEE 1/4" MP	1	
7#	49345	VALVE, RELIEF 1/4" MNPT 100PSI	1	
8#	49289	CLUTCH, AIR MECHANICAL	1	
9	49071	NUT, HFS, 5/16"-18	1	
10	49314	BRACKET, IDLER	1	
11	9091	SCREW, HHFS 5/16"-18 X 1 GRD 5	1	
12	19266	NUT, BLIND	7	
13	60097	LOCTITE™ #246, BLUE	1	
14#	492339	SCREW, HHC, ZP M6-1.0 X 60, CLASS 8.8	1	
15#	49070	NUT, HFS 1/4"-20	3	
16	49347	SCREW, HHC 1/4"-20 X 3-1/2"	1	
17#	49272	PUMP COMPRESSOR BRACKET	1	
18#	0948	WASHER, FLAT SAE 1/4"	3	
20#	49269	COMPRESSOR, AIR	1	
21#	49048	SCREW, HHFS 1/4"-20 X 3/4" GRD 5	10	
22	49353	GUARD, LEFT	1	
23	49340	CART COMPRESSOR ASSEMBLY	1.....	INCLUDES ITEMS W/#
24	49260	OIL, AIR COMP. ISO 100 SAE 30 (.094 QT.).....	1.....	1-BTL=1QT

Go to Discount-Equipment.com to order your parts

PUMP ASSY.

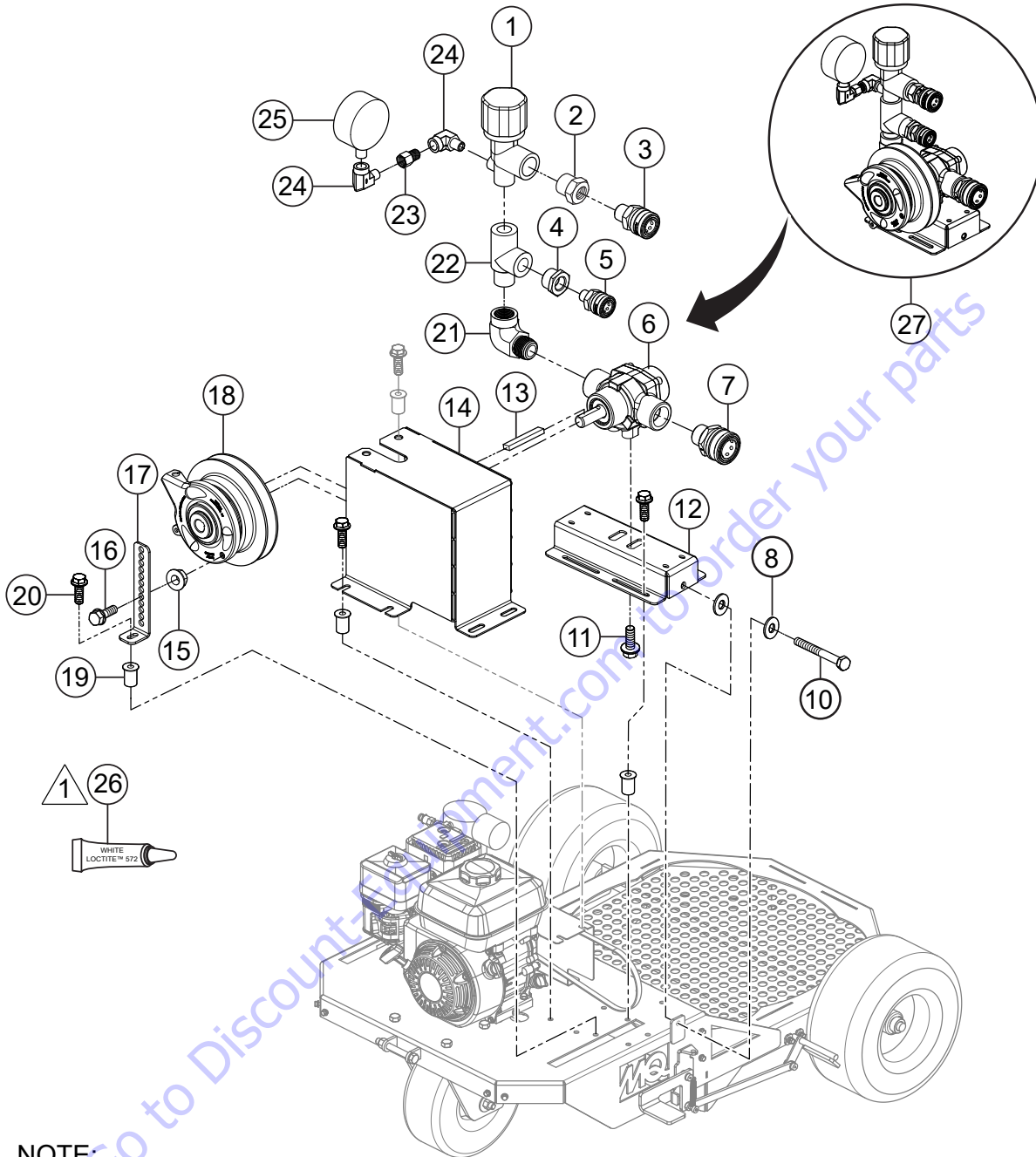

NOTE:

- 1 APPLY LOCTITE™ 572
TO ALL PIPE CONNECTIONS ON ITEMS 1-7
AND 21-25.

PUMP ASSY.

<u>NO.</u>	<u>PART NO.</u>	<u>PART NAME</u>	<u>QTY.</u>	<u>REMARKS</u>
1#	49309	REGULATOR, PRESSURE	1	
2#	16585	FITTING, BUSH 1/2" FP-3/4" MP	1	
3#	49327	FITTING, 1/2" MNPT FEMALE QUICK	1	
4#	49333	FITTING, BRASS 3/4" MNPT-3/8" FNPT	1	
5#	49328	FITTING, 3/8" MNPT FEMALE QUICK	1	
6#	49261	PUMP, 4 ROLLER 5/8" SHAFT REWORK	1	
7#	49326	FITTING 3/4" MNPT FEMALE QUICK	1	
8	0948	WASHER, FLAT SAE 1/4"	2	
10	49347	SCREW HHC 1/4"-20 X 3-1/2"	1	
11#	34002	SCREW HHC 1/4"-20 X 3-1/2"	2	
12#	49263	BRACKET, PUMP	1	
13#	584013	KEY, 3/16" X 1" SQ.	1	
14	49352	GUARD, RIGHT	1	
15	49071	NUT, HFS, 5/16"-18	1	
16	9091	SCREW, HHFS 5/16"-18 X 1 GRD 5	1	
17	49314	BRACKET, IDLER	1	
18#	49290	CLUTCH, PUMP MECHANICAL	1	
19#	19266	NUT, BLIND	9	
20	49048	SCREW, HHFS 1/4"-20 X 3/4" GRD 5	5	
21#	49335	FITTING, 90° 3/4" FNPT X 3/4" MNPT	1	
22#	59156	FITTING, RUN TEE 12 MP-12 FP-12 FP	1	
23#	30384	FITTING, 1/4" MNPT X 1/4" FNPT	1	
24#	8053	FITTING, 90° 1/4" FP-1/4" MP	2	
25#	49310	GAUGE, 300PSI LIQUID	1	
26	60096	LOCTITE™ #572, WHITE	1	
27	49339	CART PUMP ASSEMBLY	1.....	INCLUDES ITEMS W/#

ENGINE ASSY.

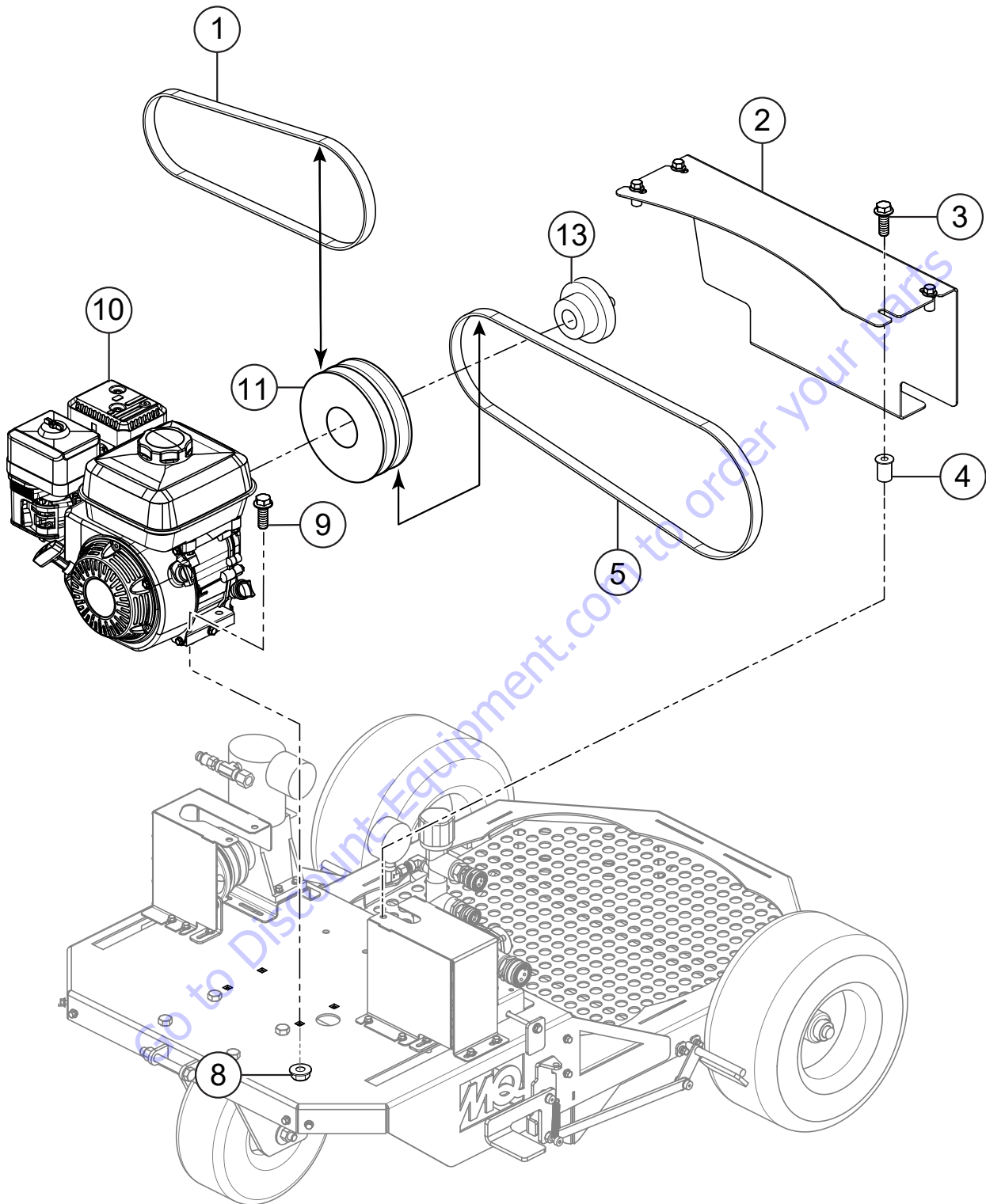

ENGINE ASSY.

<u>NO.</u>	<u>PART NO.</u>	<u>PART NAME</u>	<u>QTY.</u>	<u>REMARKS</u>
1	49273	BELT, AX26	1	
2	49354	GUARD, CENTER	1	
3	49048	SCREW, HHFS 1/4"-20 X 3/4" GRD 5	6	
4	19266	NUT, BLIND	11	
5	49311	BELT, AX37	1	
8	49071	NUT, HFS, 5/16"-18	6	
9	21906	SCREW, HHFS 5/16"-18 X 1-1/2" GRD 5	4	
10	49282	ENGINE, HONDA 4.8 HP	1	
11	49293	PULLEY, 24AK46, TYPE H BUSHING	1	
13	49355	BUSHING, 20 MM	1	

Go to Discount-Equipment.com to order your parts

WHEEL ASSY.

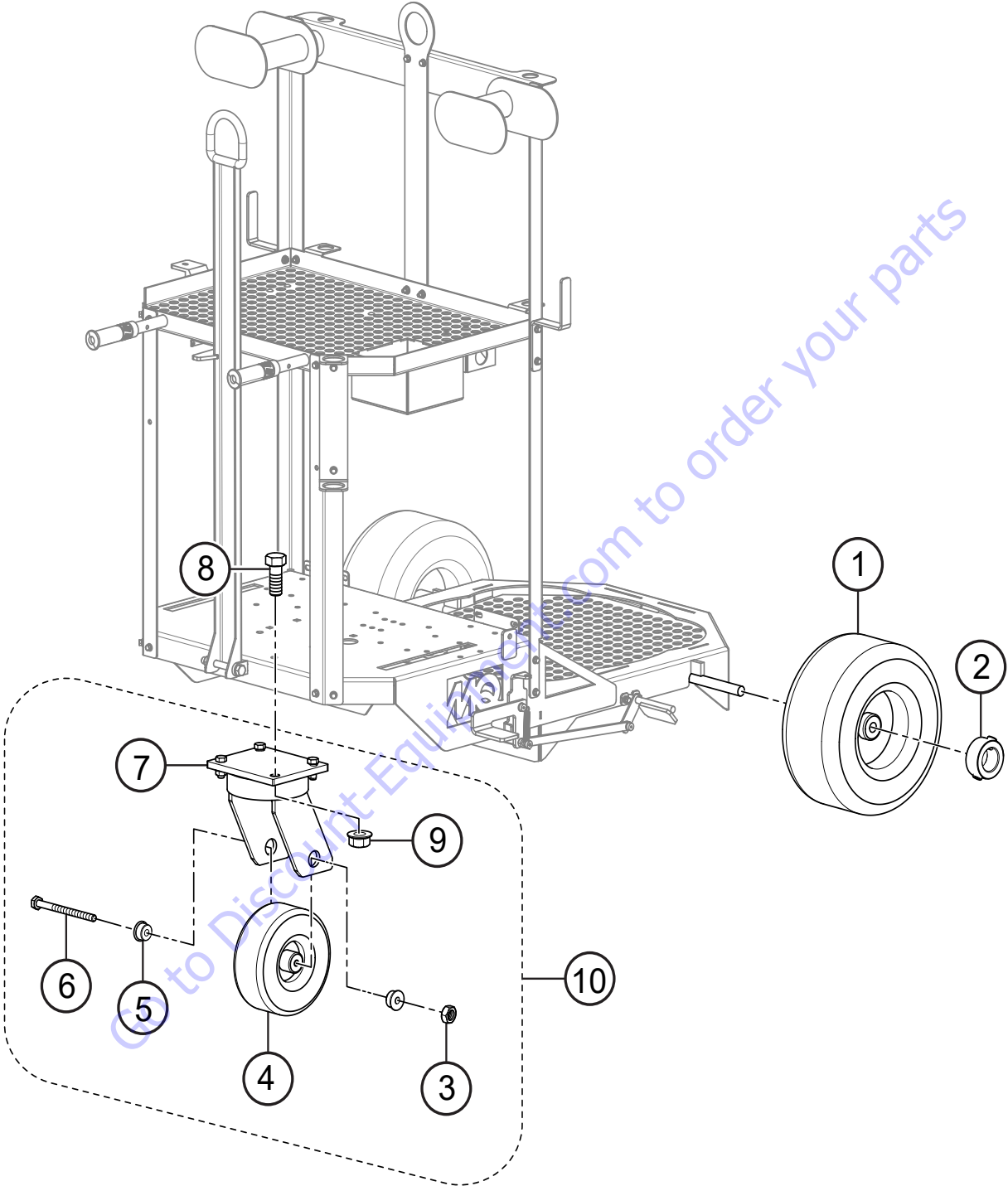

WHEEL ASSY.

<u>NO.</u>	<u>PART NO.</u>	<u>PART NAME</u>	<u>QTY.</u>	<u>REMARKS</u>
1	49229	TIRE, REAR CART	2	
2	2367	COLLAR, SET .75 X 1.25 X .56	2	
3#	49228	NUT, TOP LOCK 1/2"-13 GRD C/ GRD 5	1	
4#	49275	TIRE, FRONT CART	1	
5#	49277	BUSHINGS, FRONT CASTER	2	
6#	49283	SCREW HHC 1/2"-13 X 6-1/4"	1	
7#	49276	BRACKET, CASTER FRONT	1	
8	3214	SCREW, HHC 1/2"-13 X 1-1/4"	4	
9#	26328	NUT, HFS 1/2"-13	4	
10	49230	CASTER, CART FRONT ASSEMBLY	1.....	INCLUDES ITEMS W/#

Go to Discount-Equipment.com to order your parts

BRAKE ASSY.

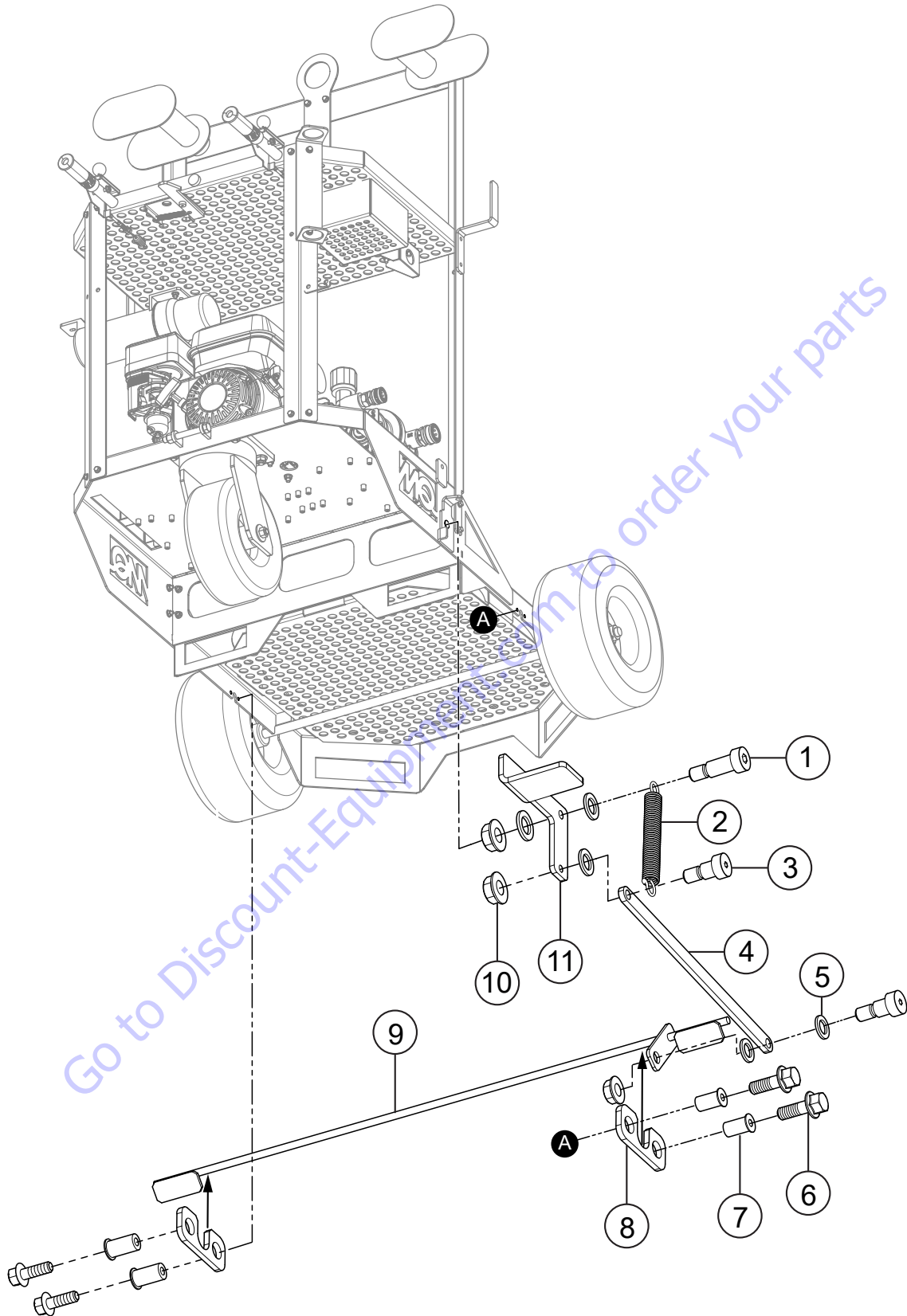

BRAKE ASSY.

<u>NO.</u>	<u>PART NO.</u>	<u>PART NAME</u>	<u>QTY.</u>	<u>REMARKS</u>
1	3910382	BOLT, PLATED SHOULDER, 3/8" X 3/8"	2	
2	20559-001	SPRING, EXTENSION 3.38 FL. X .71 OD. X .105	1	
3	49337	SCREW, SHOULDER 3/8" X 3/4", 5/16"-18 SOCKET HEAD	1	
4	49318	CONNECTING BRAKE BAR	1	
5	35235	WASHER, NYLON, 3/8" ID. X .06 THK.	5	
6	49048	SCREW, HHFS 1/4"-20 X 3/4" GRD 5	4	
7	29452	NUT, BLIND 1/4"-20 X .165-.260	4	
8	49316	MOUNT, BRAKE AXLE	2	
9	49323	BRAKE AXLE	1	
10	49071	NUT, HFS 5/16"-18	3	
11	49317	BRAKE LEVER	1	

Go to Discount-Equipment.com to order your parts

CART HOSE ASSY.

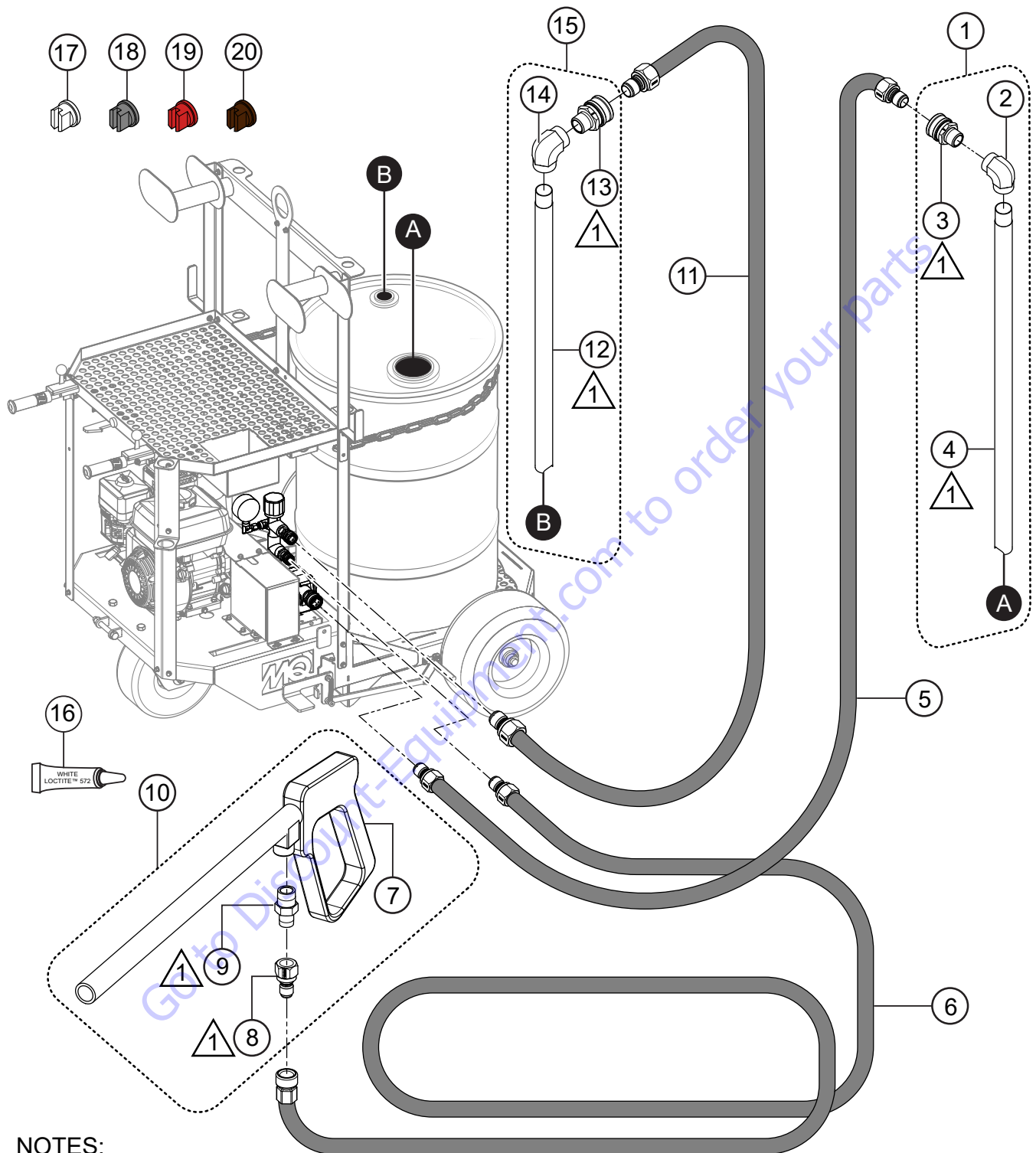

NOTES:

 APPLY LOCTITE™ #572

CART HOSE ASSY.

<u>NO.</u>	<u>PART NO.</u>	<u>PART NAME</u>	<u>QTY.</u>	<u>REMARKS</u>
1	49280	SUCTION TUBE ASSEMBLY	1.....	INCLUDES ITEMS W/#
2#	49332	FITTING, 90° 3/4" FNPT-3/4" FNPT	1	
3#	49326	FITTING, 3/4" MNPT FEMALE QUICK	1	
4#	49244	TUBE, SUCTION	1	
5	49307	HOSE, 5' X 3/4" SUCTION ASSEMBLY	1	
6	49303	HOSE, 50' 3/8" ASSEMBLY	1	
7%	49243	GUN, SPRAY	1	
8%	49331	FITTING, 3/8" FNPT MALE QUICK	1	
9%	32723	FITTING, 1/2"-14 MNPT X 3/8"-18 MNPT	1	
10	49284	SPRAY GUN ASSEMBLY	1.....	INCLUDES ITEMS W/%
11	49305	HOSE, 5' X 1/2" RETURN ASSEMBLY	1	
12@	49245	TUBE, RETURN	1	
13@	49327	FITTING 1/2" MNPT FEMALE QUICK	1	
14@	49336	FITTING, 90° 1/2" FNPT-1/2" FNPT	1	
15	49281	RETURN TUBE ASSEMBLY.....	1.....	INCLUDES ITEMS W/@
16	60096	LOCTITE™ #572, WHITE	1	
17	49254	SPRAY, FLAT TIP WHITE	1	
18	49251	SPRAY, FLAT TIP GREY	1	
19	49250	SPRAY, FLAT TIP RED	1	
20	49247	SPRAY, FLAT TIP BROWN	1	

Go to Discount-Equipment.com to order your parts

BARREL MOUNT ASSY.

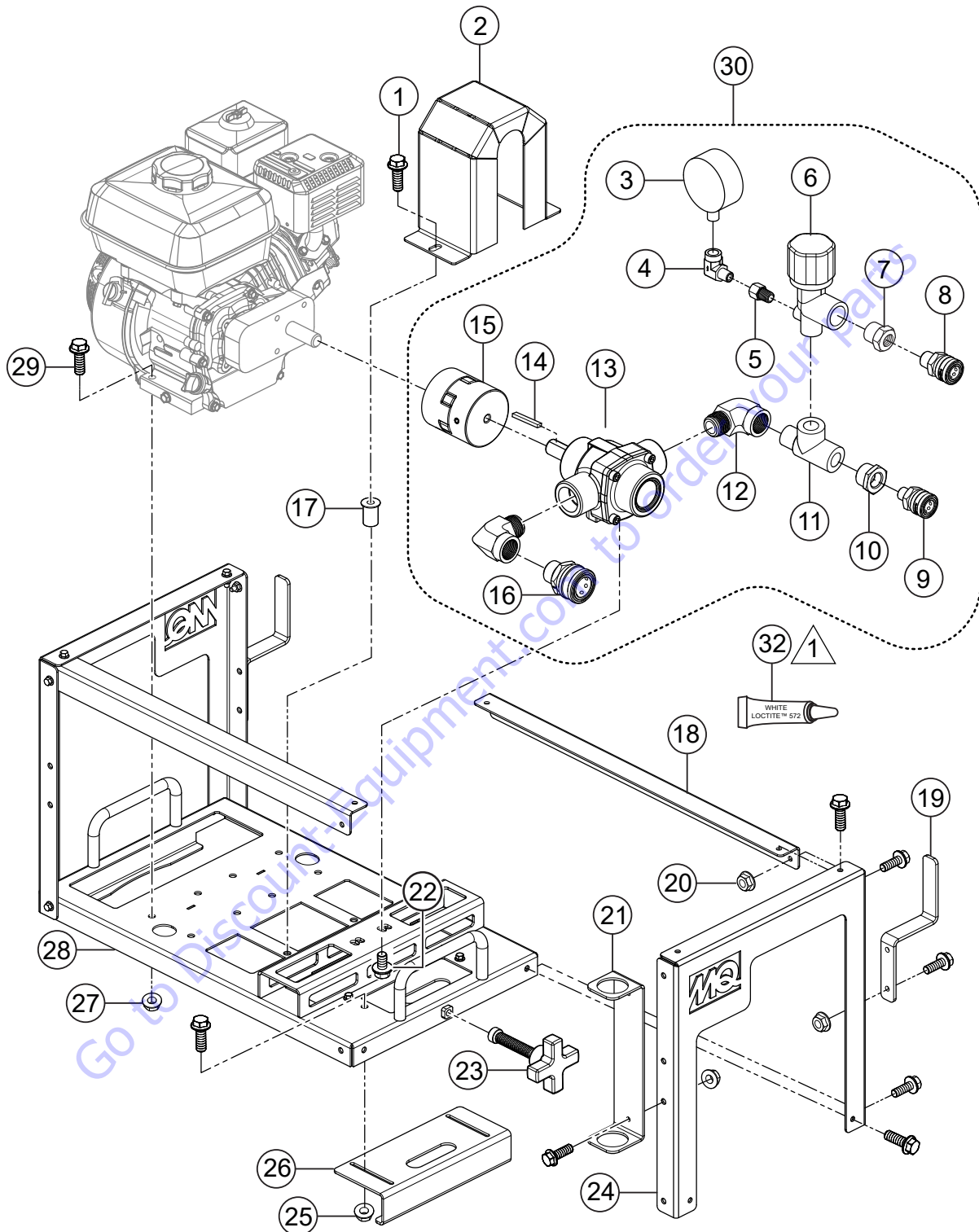

NOTE:

 APPLY LOCTITE™ #572
TO ALL PIPE CONNECTIONS ON ITEMS 3-16.

BARREL MOUNT ASSY.

<u>NO.</u>	<u>PART NO.</u>	<u>PART NAME</u>	<u>QTY.</u>	<u>REMARKS</u>
1	49048	SCREW, HHFS 1/4"-20 X 3/4" GRD 5	27	
2	49253	GUARD, COUPLING TOP	1	
3#	49310	GAUGE 300PSI LIQUID	1	
4#	8053	FITTING, 90° 1/4" FP-1/4" MP	1	
5#	30384	FITTING, 1/4" MNPT X 1/4" FNPT	1	
6#	49309	REGULATOR, PRESSURE	1	
7#	16585	FITTING, BUSH 1/2" FP-3/4" MP	1	
8#	49327	FITTING, 1/2" MNPT FEMALE QUICK	1	
9#	49328	FITTING, 3/8" MNPT FEMALE QUICK	1	
10#	49333	FITTING, BRASS 3/4" MNPT-3/8" FNPT	1	
11#	59156	FITTING, RUN TEE 12 MP-12 FP-12 FP	1	
12#	49335	FITTING, 90° 3/4" FNPT X 3/4" MNPT	2	
13#	49261	PUMP, 4 ROLLER 5/8" SHAFT REWORK	1	
14#	584013	KEY, 3/16" X 1" SQ.	1	
15#	49240	COUPLING, 3/4"-15/16"	1	
16#	49326	FITTING, 3/4" MNPT FEMALE QUICK	1	
17	49694	NUT, BLIND 1/4"-20	2	
18	49249	CAGE, TOP	2	
19	49215	HOLDER, HOSE	2	
20	49070	NUT, HFS, 1/4"-20	21	
21	49214	HOLDER, SPRAY NOZZLE	1	
22	34002	SCREW, HHC 1/4"-20 X 3-1/2"	2	
23	49239	SCREW, THUMB 3/8"-16 X 2"	1	
24	49248	CAGE, ENDS	2	
25	10024	NUT, NYLOC 1/4"-20	4	
26	49236	BRACKET, ADJUSTMENT	1	
27	49071	NUT, HFS, 5/16"-18	4	
28	49231	SKID, MOTOR PUMP	1	
29	21906	SCREW, HHFS 5/16"-18 X 1-1/2" GRD 5	4	
30	49343	SKID PUMP ASSEMBLY	1	INCLUDES ITEMS W/#
32	60096	LOCTITE™ #572, WHITE	1	

Go to [DiscountChemical.com](http://www.discountchemical.com) to order your parts

ENGINE SERVICE PARTS

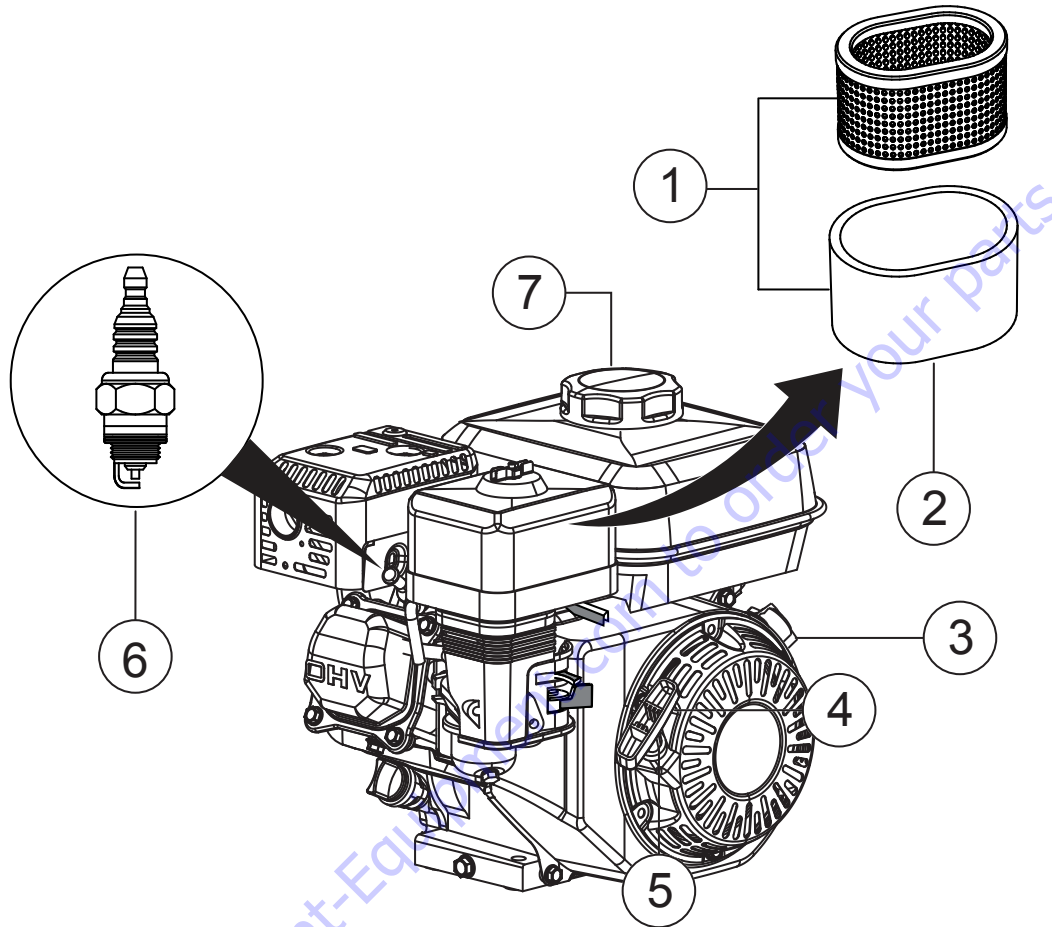

ENGINE SERVICE PARTS

<u>NO.</u>	<u>PART NO.</u>	<u>PART NAME</u>	<u>QTY.</u>	<u>REMARKS</u>
1	17210ZE1517	ELEMENT, AIR CLEANER (DUAL).....	1.....	INCLUDES ITEMS W/#
2#	17218ZE1507	FILTER, OUTER	1	
3	35120Z0T851	SWITCH ASSY., ENGINE STOP	1	
4	28461Z4M305	GRIP, RECOIL STARTER	1	
5	28462ZH8003	ROPE, RECOIL STARTER	1	
6	9807955876	SPARK PLUG	1	
7	17620Z4H900	CAP, FUEL	1	

Go to Discount-Equipment.com to order your parts

PARTS FINDER

**Search Website
by Part Number**



**Search Manual
Library For Parts
Manual & Lookup Part
Numbers – Purchase
or Request Quote**

A screenshot of the "Search Manuals" form. The form has a title "Search Manuals" and a subtitle "Please provide information to help us locate the manual and/or parts you need." It includes fields for "Brand", "Model", "Serial", "Part Number", and "Quantity". There is a "Search" button at the bottom.

**Can't Find Part or
Manual? Request Help
by Manufacturer,
Model & Description**

A screenshot of the "Parts Order Form". The form has a title "Parts Order Form" and a subtitle "Please fill in as much information as possible." It includes fields for "Manufacturer", "Model", "Description", "Part Number", "Quantity", and "Comments". There is a "Submit" button at the bottom.

Discount-Equipment.com is your online resource for quality parts & equipment.

Florida: **561-964-4949** Outside Florida TOLL FREE: **877-690-3101**

Need parts?

Click on this link: <http://www.discount-equipment.com/category/5443-parts/> and choose one of the options to help get the right parts and equipment you are looking for. Please have the machine model and serial number available in order to help us get you the correct parts. If you don't find the part on the website or on one of the online manuals, please fill out the request form and one of our experienced staff members will get back to you with a quote for the right part that your machine needs.

We sell worldwide for the brands: Genie, Terex, JLG, MultiQuip, Mikasa, Essick, Whiteman, Mayco, Toro Stone, Diamond Products, Generac Magnum, Airman, Haulotte, Barreto, Power Blanket, Nifty Lift, Atlas Copco, Chicago Pneumatic, Allmand, Miller Curber, Skyjack, Lull, Skytrak, Tsurumi, Husquvarna Target, , Stow, Wacker, Sakai, Mi-T- M, Sullair, Basic, Dynapac, MBW, Weber, Bartell, Bennar Newman, Haulotte, Ditch Runner, Menegotti, Morrison, Contec, Buddy, Crown, Edco, Wyco, Bomag, Laymor, Barreto, EZ Trench, Bil-Jax, F.S. Curtis, Gehl Pavers, Heli, Honda, ICS/PowerGrit, IHI, Partner, Imer, Clipper, MMD, Koshin, Rice, CH&E, General Equipment, ,AMida, Coleman, NAC, Gradall, Square Shooter, Kent, Stanley, Tamco, Toku, Hatz, Kohler, Robin, Wisconsin, Northrock, Oztec, Toker TK, Rol-Air, Small Line, Wanco, Yanmar

OPERATION AND PARTS MANUAL

HERE'S HOW TO GET HELP

PLEASE HAVE THE MODEL AND SERIAL
NUMBER ON-HAND WHEN CALLING

Go to Discount-Equipment.com to order your parts

Your Local Dealer is:



www.Discount-Equipment.com



PN: 49356