

IM R SERIES

TRACK DRIVEN CRAWLER ACCESS PLATFORMS | INDOOR / OUTDOOR

IM R 19 Lithium

PERFORMANCE

Platform Height 56'
Working Height 62'

STANDARD EQUIPMENT

- Automatic outrigger leveling system
- 355° rotation (non-continuous)
- 120V, 15 amp electric motor for indoor use
- Air / Water outlet in the platform basket
- 120V AC power to platform
- Removable wireless control box
- Tether for wired connectivity
- Max 510 lbs in basket (two person capacity)
- Three travel speeds
- Emergency hand pump
- Cylinder holding valve
- Hour meter
- Load and tip detection sensor
- Load cell
- Hydraulic jib
- Rubber tracks
- Remote battery charger
- Removable basket with 1 pin detach
- Overload sensor
- 120V battery charger
- Proportional controls with diagnostics
- Hydraulically adjustable track width
- Oversized 14" outrigger pads
- Hydraulic basket rotation - 124°

OPTIONAL EQUIPMENT

- Non-marking rubber tracks
- Working light in the platform basket
- 12 V emergency pump
- 120 V desktop remote charge
- Sliding & oversized outrigger pads
- IMERVIEW GPS Remote Monitor System

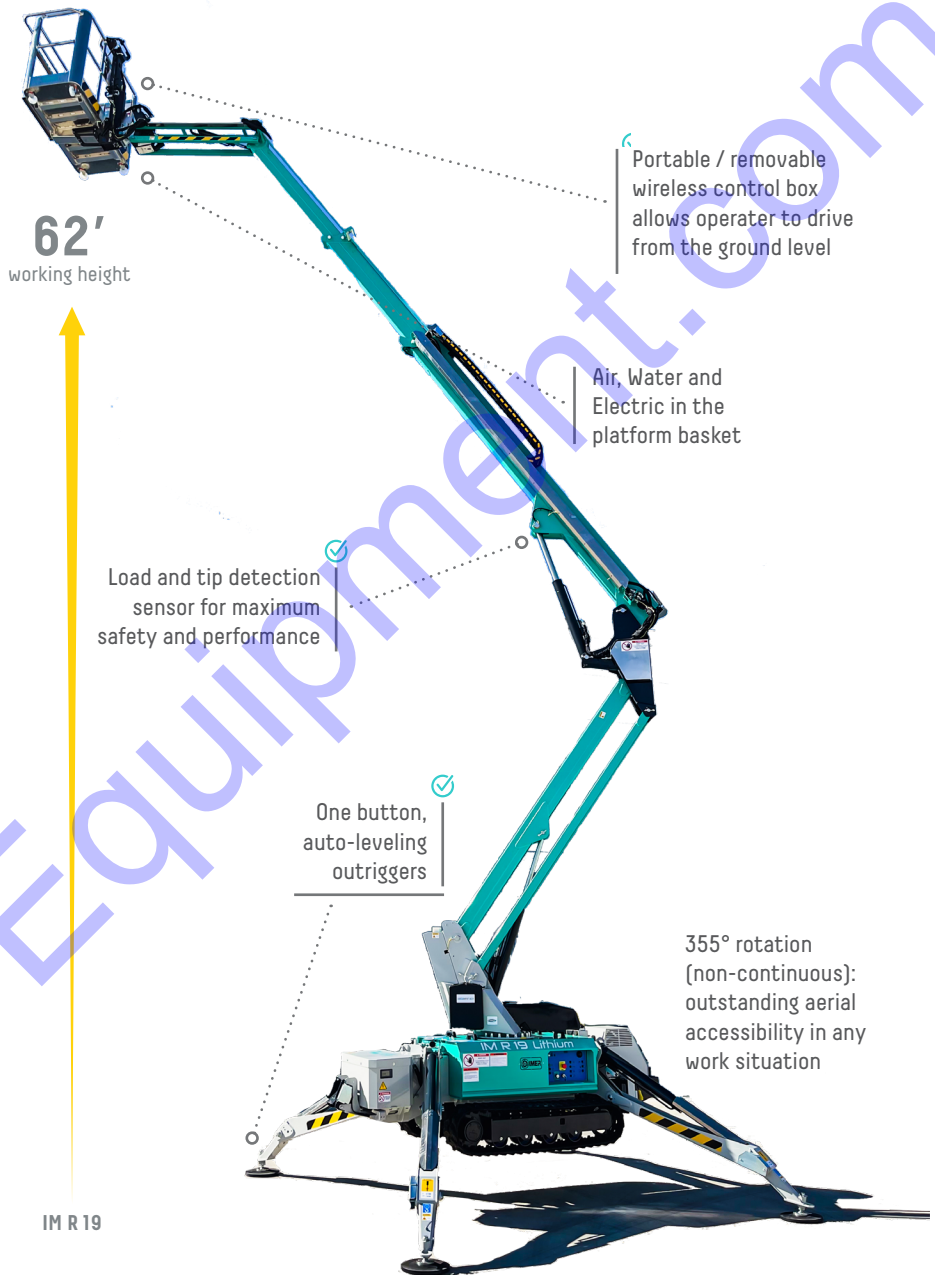

Compact 31" width allows access in narrow, hard to reach places



Easy access both outdoor and indoor.
Non-marking tracks for indoor use



IM R SERIES

TRACK DRIVEN CRAWLER ACCESS PLATFORMS | INDOOR / OUTDOOR



This machine meets or exceeds applicable ANSI and CSA requirements based on machine configuration as originally manufactured for intended applications. Reference the serial number plate on the machine for additional information.



FAST & SECURE LEVELING
Automatic outrigger leveling system for quick set up and peace of mind.

EASY USER EXPERIENCE
A user-friendly control panel, easily removable wireless remote control allows for more space in the basket and navigation from the ground.

EASY ACCESS
In addition to the removeable control box in the basket, the IM R Series includes an easy to access ground control panel.

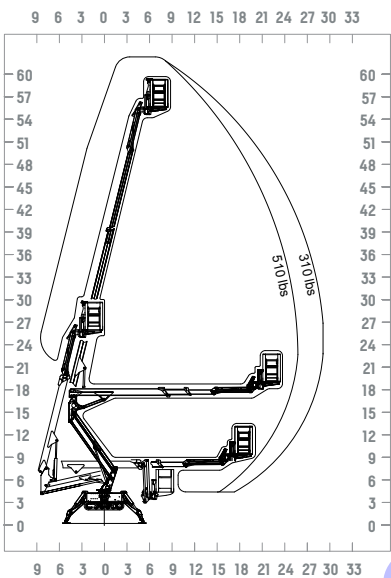

ADJUSTABLE TRACKS
Hydraulically adjust the track width for added stability and traction, and to fit through narrow doorways and gates for interior or exterior projects

LITHIUM POWER
Lithium batteries and AC electric motor for ultra-high performance

SUPERIOR ROTATION
Outstanding accessibility with a 355° rotation (non-continuous) and 124° jib rotation

	IM R 19 Li	
Working height	ft	62'
Platform height	ft	56'
Side outreach (weight in basket)	ft / lb	32' / 176 - 28' / 310 - 23' / 510
Rotation (non-continuous)	deg	355°
Basket dimensions	in	57" x 28" x 43"
Basket rotation	deg	124°
Transport length (without basket)	ft	17' 5" / 15' 2"
Transport width (without basket)	ft	Max 3' 6" / Min 2' 7"
Height in stowed position	ft	Min 6' 6" / Max 6' 11"
Overall outrigger footprint	ft	11' 6" x 12
Stabilizer load	ft-lb	3930
Driving speed	mph	0 - 1.50
Gradeability	%	32%
Platform capacity	lb	510
Machine weight	lb	5370

*w/ stabilizers in position

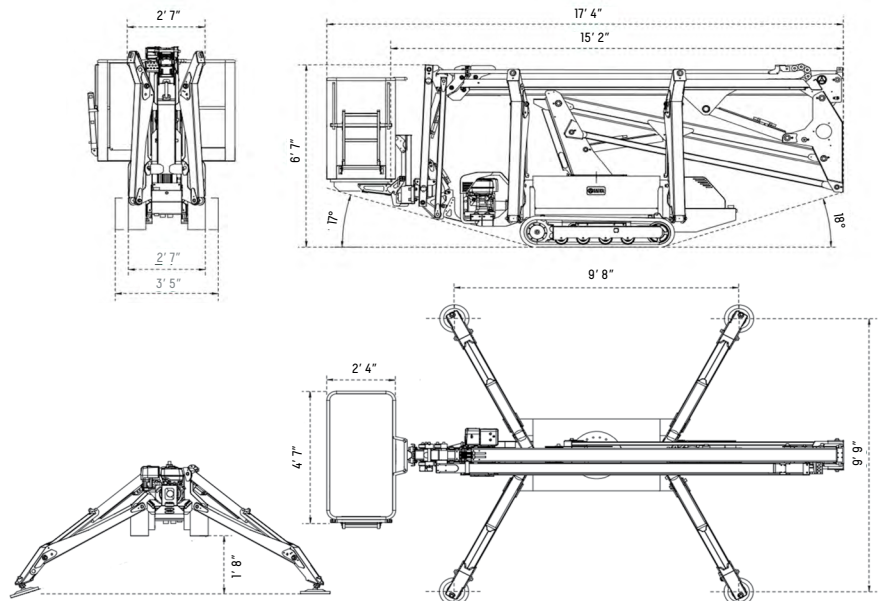

www.Discount-Equipment.com IMER USA, Inc.