

IM R SERIES

TRACK DRIVEN CRAWLER ACCESS PLATFORMS | INDOOR / OUTDOOR

IM R 19



PERFORMANCE

Platform Height 56'
Working Height 62'

STANDARD EQUIPMENT

- Automatic outrigger leveling system
- 355° rotation (non-continuous)
- 120V, 15 amp electric motor for indoor use
- Air / Water outlet in the platform basket
- 120V AC power to platform
- Removable wireless control box
- Tether for wired connectivity
- Max 510 lbs in basket (two person capacity)
- Three travel speeds
- Emergency hand pump
- Cylinder holding valve
- Hour meter
- Load and tip detection sensor
- Load cell
- Hydraulic jib
- Rubber tracks
- Remote battery charger
- Removable basket with 1 pin detach
- Overload sensor
- 120V battery charger
- Proportional controls with diagnostics
- Honda GX390 Engine
- Hydraulically adjustable track width
- Oversized 14" outrigger pads
- Hydraulic basket rotation - 124°

62'
working height

IM R 19

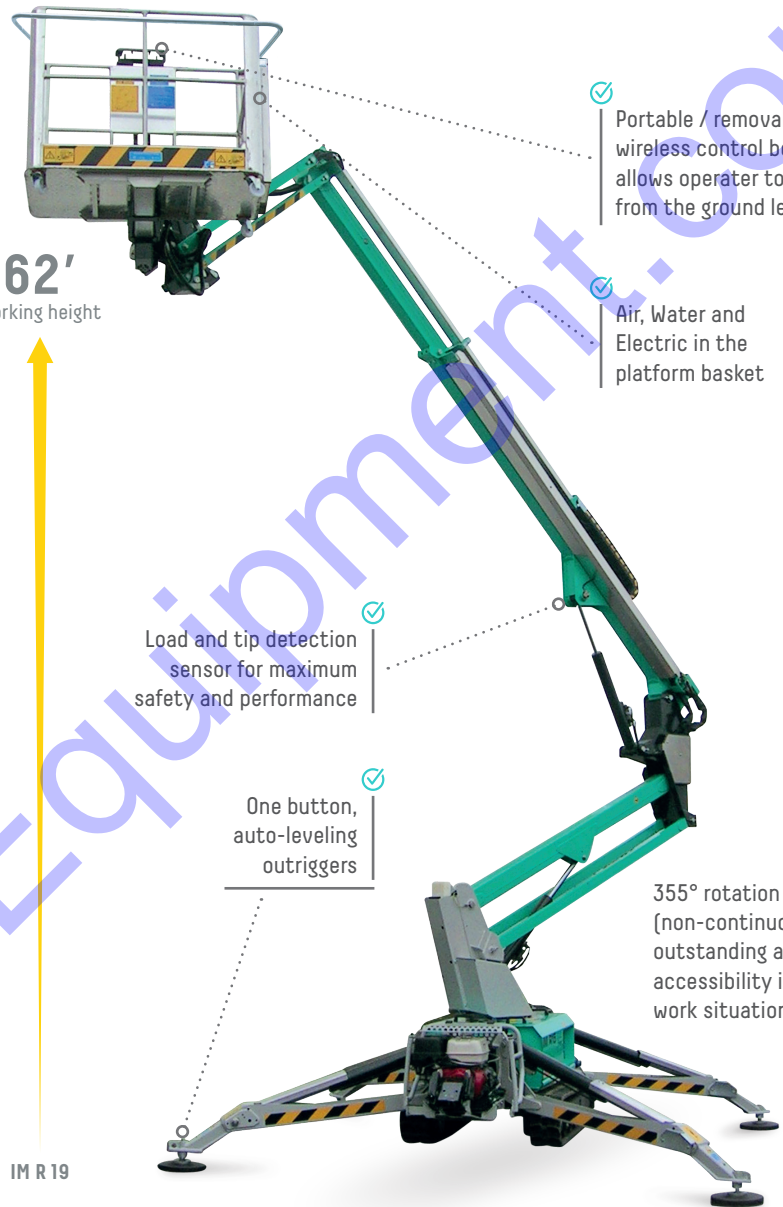

✓ Portable / removable wireless control box allows operator to drive from the ground level

✓ Air, Water and Electric in the platform basket

✓ Load and tip detection sensor for maximum safety and performance

✓ One button, auto-leveling outriggers

355° rotation (non-continuous): outstanding aerial accessibility in any work situation

OPTIONAL EQUIPMENT

- Non-marking rubber tracks
- Working light in the platform basket
- 12 V emergency pump
- 120 V desktop remote charge
- Sliding & oversized outrigger pads
- IMERVIEW GPS Remote Monitor System



Compact 31" width allows access in narrow, hard to reach places



Easy access both outdoor and indoor.
Non-marking tracks for indoor use



IM R SERIES

TRACK DRIVEN CRAWLER ACCESS PLATFORMS | INDOOR / OUTDOOR



This machine meets or exceeds applicable ANSI and CSA requirements based on machine configuration as originally manufactured for intended applications. Reference the serial number plate on the machine for additional information.



9 6 3 0 3 6 9 12 15 18 21 24 27 30 33

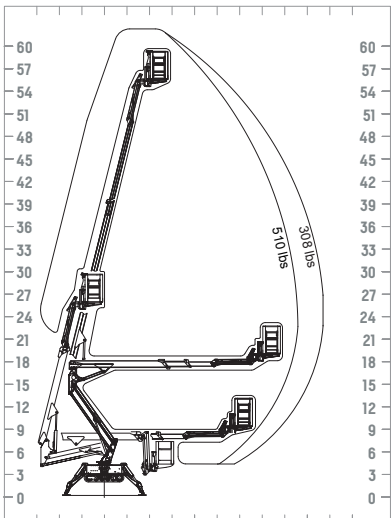

9 6 3 0 3 6 9 12 15 18 21 24 27 30 33



FAST & SECURE LEVELING

Automatic outrigger leveling system for quick set up and peace of mind.



EASY USER EXPERIENCE

A user-friendly control panel, easily removable wireless remote control allows for more space in the basket and navigation from the ground.



EASY ACCESS

In addition to the removeable control box in the basket, the IM R Series includes an easy to access ground control panel.



ADJUSTABLE TRACKS

Hydraulically adjust the track width for added stability and traction, and to fit through narrow doorways and gates for interior or exterior projects



BI-ENERGY POWER

A Honda Engine and Electric Motor provide a bi-energy solution, allowing both indoor and outdoor use (shown with a rugged engine guard for improved protection)



SUPERIOR ROTATION

Outstanding accessibility with a 355° rotation (non-continuous) and 124° jib rotation

		IM R 19
Working height	ft	62'
Platform height	ft	56'
Side outreach (weight in basket)	ft / lb	32' / 176 - 28' / 310 - 23' / 510
Rotation (non-continuous)	deg	355°
Basket dimensions	in	57" x 28" x 43"
Basket rotation	deg	124°
Transport length (without basket)	ft	17' 5" / 15' 2"
Transport width (without basket)	ft	Max 3' 6" / Min 2' 7"
Height in stowed position	ft	Min 6' 6" / Max 6' 11"
Overall outrigger footprint	ft	11' 6" x 12
Stabilizer load	ft-lb	3930
Driving speed	mph	0 - 1.25
Gradeability	%	32%
Platform capacity	lb	510
Gas motor		Honda GX390
Machine weight	lb	5370

*w/ stabilizers in position

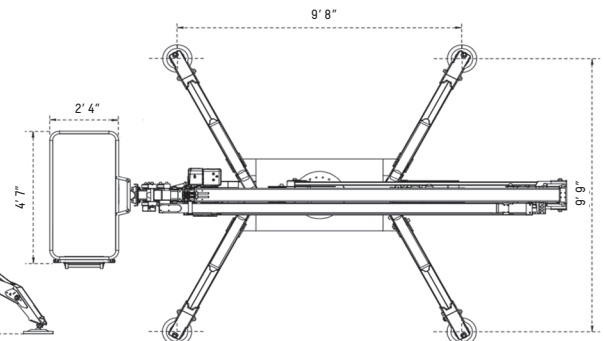
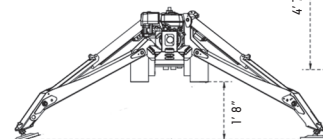
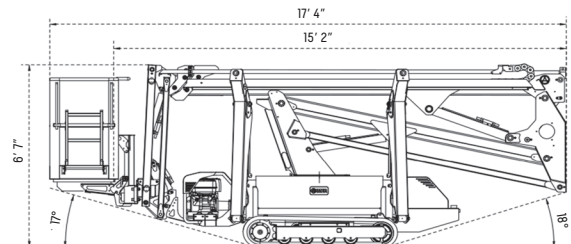
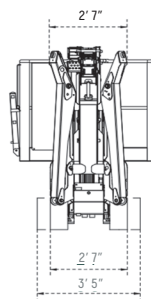

www.Discount-Equipment.com

IMER USA, Inc.